

8-Band HF Vertical 80 thru 10 Meters

Model DX-88
Instruction Manual

**Downloaded by
RadioAmateur.EU**

Please record the following information for your records: Date

of Purchase: _____

Purchased From: _____

Price Paid: _____

Please retain your copy of the Bill-of-sale for warranty claims.

TABLE OF CONTENTS

Chapter 1.....	1-1
General Description	1-1
Electrical Design.....	1-1
Mechanical Design.....	1-1
Specifications	1-2
Typical VSWR Curves.....	1-2
Chapter 2.....	2-1
Preparation for Assembly	2-1
Tools.....	2-1
Chapter 3.....	3-1
Base Assembly.....	3-1
80/40 Meter Assembly.....	3-1
Capacitor Assembly.....	3-1
Attaching Capacitors to Coil Assembly.....	3-1
10/12/15 Meter Trap Assembly	3-3
Capacitor Assembly	3-3
Attaching Capacitor to Coil Assembly.....	3-4
17/20 Meter Assembly	3-5
Capacitor Assembly	3-5
Attaching Capacitors to Coil Assembly.....	3-6
30 Meter Trap Assembly	3-7
Attaching Capacitors to Coil Assembly.....	3-7
Attaching Upper Radiator Tubes to 30 Meter Trap Assembly.....	3-8
Installation of Tubing Clamp.....	3-9
Attaching the Trap Assemblies.....	3-10
DC Shorting Coil.....	3-10
Tuning the DX-88 Vertical Antenna.....	3-12
Chapter 4.....	4-1
Mounting the Antenna	4-1
Operation	4-4
Service Information	4-4
VSWR Record.....	4-5
Converting American Measurements to Metric.....	4-6
Chapter 5.....	5-1
Parts List.....	5-1

LIST OF ILLUSTRATIONS

Figure		Page
1	Base Assembly	3-1
2	80/40 Meter Assembly	3-2
Detail A	45" Capacitor Assembly	3-2
Detail B	1 1/8" x 1" Mast/Capacitor Clamp	3-2
Detail C	1 1/8" x 7/16" Mast/Capacitor Clamp	3-2
3	10/12/15 Meter Capacitor Assemblies	3-3
Detail A	13" Capacitor Assembly	3-3
Detail B	16" Capacitor Assembly	3-3
4	10/12/15 Meter Trap Assembly	3-4
Detail A	1 1/8" x 1" Mast/Capacitor Clamp	3-4
Detail B	1 1/8" x 7/16" Mast/Capacitor Clamp	3-4
5	17/20 Meter Capacitor Assemblies	3-5
Detail A	13" Capacitor Assembly	3-5
Detail A	16" Capacitor Assembly	3-5
6	17/20 Meter Trap Assembly	3-6
Detail B	1 1/8" x 1" Mast/Capacitor Clamp	3-6
Detail C	1 1/8" x 7/16" Mast/Capacitor Clamp	3-6
7	30 Meter Trap Assembly	3-7
Detail A	1" Mast/Capacitor Clamp	3-7
Detail B	3/8" x 1" x 3/8" Mast/Capacitor Clamp	3-7
8	Upper Radiator Tubes Attached to 30 Meter Trap Assembly	3-8
9	Tubing Clamps	3-9
10	DC Shorting Coil	3-10
11	Connecting Trap Assemblies	3-11
12	DX-88 Overall View	3-16
13	DX-88 Ground Mount Radial System	4-1
14	DX-88 Resonant Radial System	4-2
15	Roof Mounted Radial System	4-3

LIST OF GRAPHS AND TABLES

Graph		Page
1	Dimension A and B, 80/40 Meter for 6.9-7.3 MHz	3-13
2	Dimension A and B, 80/40 Meter for 3.5-4.0 MHz	3-13
3	Dimension C, 10 Meter Trap for 27-29.7 MHz	3-13
4	Dimension D, 12 Meter Trap for 24.5-26.5 MHz	3-13
5	Dimension E, 15 Meter Trap for 20.5-22 MHz	3-14
6	Dimension F, 17 Meter Trap for 17.5-18.5 MHz	3-14
7	Dimension G, 20 Meter Trap for 13.5-15.5 MHz	3-14
8	Dimension H, 30 Meter Trap for 9.5-10.5 MHz	3-14

Table		Page
1	Dimension H and I for HAM and SWL Settings.....	3-15
2	Broadcasting Frequencies.....	3-15
3	Resonant Radial Lengths	4-3

CHAPTER I

GENERAL DESCRIPTION

The Hy-Gain DX-88 is an omnidirectional, unity gain, self supporting vertical antenna that operates in the Amateur 10, 12, 15, 17, 20, 30, 40, and 80 meter bands. This vertical antenna may also be tuned to provide outstanding reception in the SWL 11, 13, 16, 19, 22, 25, 31, 41, 49, 74, and 90 meter bands. The DX-88 will work against an earth ground and a set of ground radials or a resonant radial system when mounted above ground. You may construct your own radial system from information in this manual, or you may purchase the optional ground radial kit for the DX-88, Model GRK-88, Order No. 189S, or the resonant roof radial kit, Model RRK-88, Order No. 1905.

An optional 160 meter kit, Model 160 MK-88, Order No. 191S, is also available for the DX-88 vertical. The 160 meter kit is only recommended for ground-mounted installations.

Dimensions are included in this manual for optimization on either the CW or phone portions of the 80, 40, and 20 meter bands. Regardless of the optimization, the VSWR bandwidths of the DX-88 are broad enough for the antenna to operate at a VSWR of 2:1 or less on the 10, 12, 15, 17, and 30 meter bands. The bandwidth on 80 meters is approximately 50 KHz at 2:1 VSWR, because it is inductively loaded on this band. The bandwidth on 40 meters is approximately 200 KHz, and on 20 meters approximately 250 KHz.

The Omni DX-88 vertical antenna features stainless steel hardware for all electrical and most mechanical connections. The DX-88 also features heavy-wall 1 3/8 inch and 1 1/8 inch aluminum tubing for high strength and large diameter #12 copper wire coils for low loss and high-Q performance.

A high-efficiency non-automatic band-switching kit is available to add 160 meter operation to the DX-88. Model 160 MK-88, Order No. 00191S.

ELECTRICAL DESIGN

The Omni DX-88 vertical antenna utilizes its entire length for radiation on both 80 and 40 meters.

It resonates on each of these two bands with the aid of a tuned circuit near the base which looks inductive in the 3.5 - 4.0 MHz band and capacitive in the 7.0 - 7.3 MHz band. Adjustable piston capacitors set the resonance of this tuned circuit, which affects the amount of inductance and capacitance, and the resulting antenna resonances within each band.

The remaining bands are obtained by using low-loss, high-Q tunable traps to isolate one-quarter wavelength sections along the radiator. One-quarter wavelength sections always produce low-angle radiation patterns without high-angle lobes. The distances between the traps are fixed and the traps themselves are tuneable, except for the 30 meter band. This allows the antenna to operate on the new WARC bands of 12 and 17 meters as well as the older 10, 15, and 20 meter bands. This also allows the DX-88 to resonate on or very close to the international SWL bands, with the proper adjustment of each trap.

MECHANICAL DESIGN

The DX-88 mechanical design features 0.120 wall, 1 3/8 inch and 1 1/8 inch 6063T832 aluminum tubing for extra high strength. Wind survivability is 75 MPH WITHOUT guying. The large diameter coils used in the traps and 80/40 tuning circuit are constructed on large diameter high strength forms and are protected from environment by covers made from the same material. The DX-88 may be disassembled into sections of less than 55 inches for easy transportation to DX locations. All stainless steel hose clamps and hardware are used for all electrical connections. All insulators and coil covers are UV protected. The coil covers may be removed easily for cleaning, modifying or repairing the coils. When the 160 meter kit has been added, the wind survivability is 50 MPH (80 kmph).

SPECIFICATIONS

Electrical

Frequency:
 Transmit 80, 40, 30, 20, 17, 15, 12, 10 meter A m a t e u r Bands
 Receive..... 3-30 MHz, tunable in 8 International SWL Bands.
 Input impedance50 ohms
 VSWR at resonance.....less than 1.5:1 if using recommended 'radial' system
 Maximum Power* 1500 watts PEP, 700 watts average
 Input Connector 'SO-239 '*
 Maximum power on 30 meters is 250 watts average
 *Maximum power on 17 meters is 500 watts average

Mechanical

Maximum height...24' 9" (7.54 m)
 Weight, net 18 lb. (8.2 kg)
 Weight, shipping22 lb. (10.0 kg)
 Recommended Mast O.D. (Mast not supplied)..... 1 1/2" - 1 5/8" (38 - 41 mm)
 Wind Survival, ungyed.....75 MPH (121 kmph)
 Wind Survival, ungyed with 160 MK-88..... 50 MPH (80 kmph)

NOTE: If the terminals of the input connector are checked with an ohmmeter, they will show an open. THIS IS NORMAL! A DC shorting coil may be constructed from information in this manual. This coil will also improve the impedance match on the 80 meter band.

CAUTION: When using RTTY or AM, DO NOT transmit continuously at maximum power for more than 5 minutes at a time, with 5 minutes off between transmissions. Do not exceed average power limits specified for each band.

CAUTION: Do Not use a support mast smaller than 1 1/2" O.D. (38 mm). Small masts will not support this antenna.

TYPICAL VSWR CURVES:

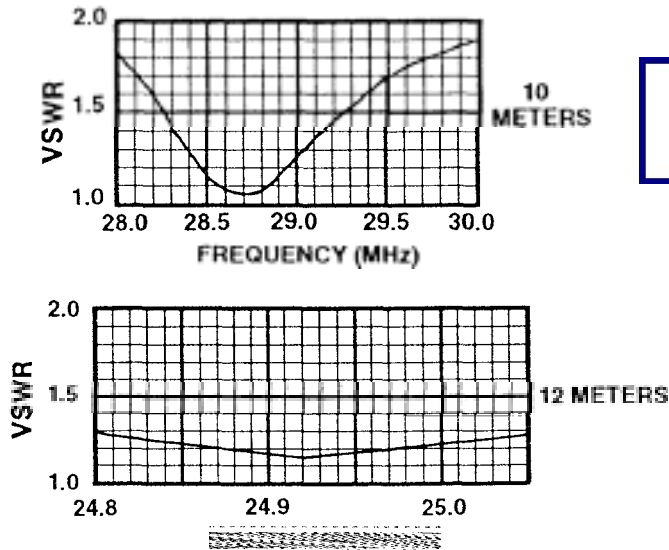

**Downloaded by
RadioAmateur.EU**

TYPICAL VSWR CURVES Cont.

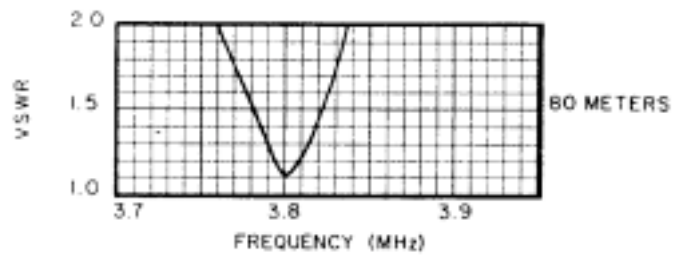
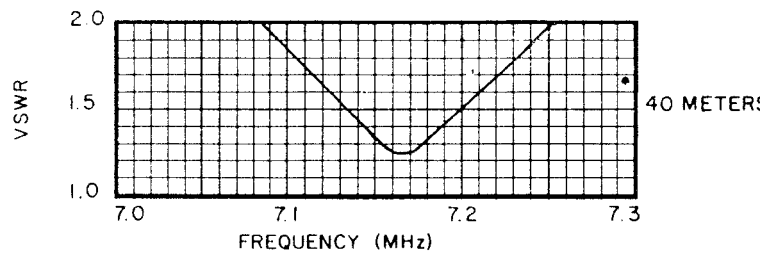
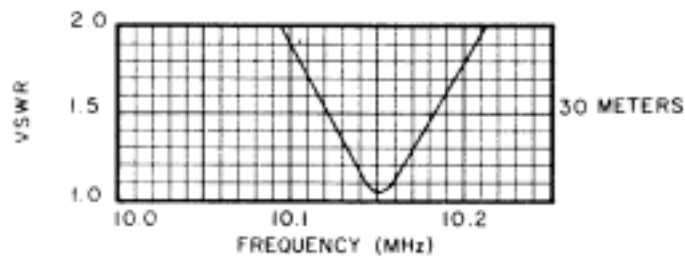
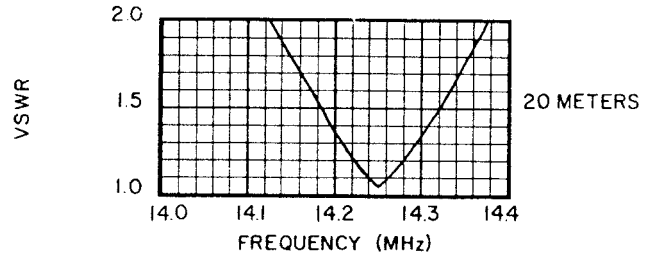
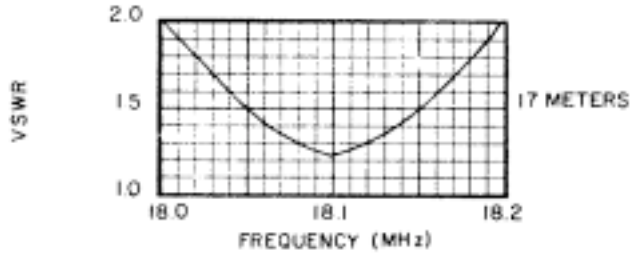
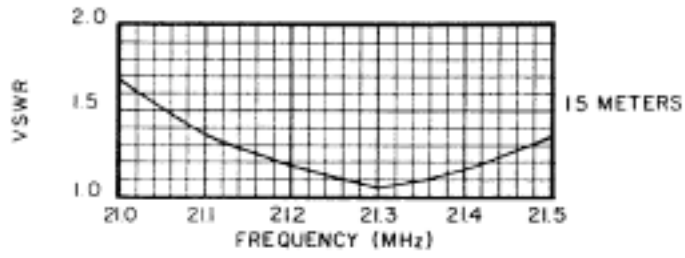

CHAPTER 2

PREPARATION FOR ASSEMBLY

FOR OVERSEAS CUSTOMERS: If you use the Metric System, see the American-To-Metric conversion table in the rear of the manual. The illustrations in this manual will provide both American and Metric Dimensions.

Choose a table-top or similarly sized clear area to assemble the Omni DX-88 vertical antenna. A bench-vise may be used to hold the tubing during assembly. If you assemble this antenna over a grassy area, precautions should be taken so that hardware is not accidentally lost during assembly.

Tools: The following tools are required for easy assembly of the Omni DX-88 antenna:

Tool Type	Qty
Tape measure, 12 ft.....	1
Nut driver, 3/8 inch	1
Nut driver, 5/16 inch	1
Open-end wrench, 1/2 inch.....	1
Open-end wrench, 7/16 inch.....	1

Standard wrenches or adjustable wrenches may be used in place of the nut drivers.

When unpacking your antenna, check inside of all tubing for small parts and elements. To conserve space, these smaller articles are sometimes put inside larger pieces. Check all parts against the parts list in the rear of this manual to ensure no parts are missing. There should be 4 coil assemblies. These may be identified by comparing them to Figures 2, 4, 6, and 7.

Make all measurements to the given dimensions, plus or minus not more than 1/8 inch. The assembly of the DX-88 will be easier if you read this manual completely through at least twice and follow the recommended directions. Allow at least 3 hours for assembly.

You may wish to assemble the DX-88 in sections in a covered area (basement, garage or workshop etc.) out of the weather and then brought outside for final assembly and installation. The Major sections are:

- Base Assembly
- 80/40 Assembly
- 10/12/15
- Assembly 17/20
- Assembly
- 30 Assembly with Item 11
- Top Assembly - Items 2 and 10

CHAPTER 8

BASE ASSEMBLY

Select the DX-88 base assembly and assemble as shown in Figure 1.

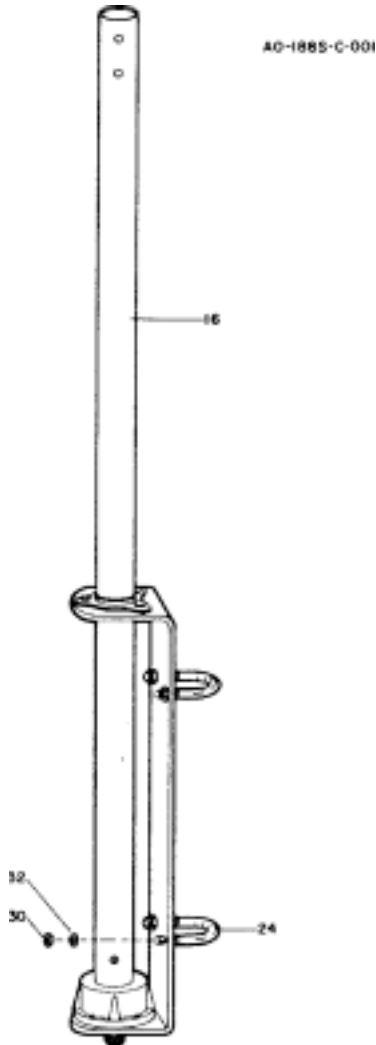

Item No.	Description
16	Base Assembly
24	U-bolt, 5/16"-1 5/8 x 2 1/4"
30	Nut, 5/16"-18, hex, ss
32	Lockwasher, 5/16", split, ss

Figure 1
Base Assembly

80/40 METER ASSEMBLY

Capacitor Assembly

Construct the two 45" capacitors for the 80/40 meter assembly. Select a 1" x 45" tube (Item 3), 7/16" x 48" tube (Item 1), 3 spacers (Item 35), 1 rain cap (Item 36), and 1 caplug (Item 34) for each capacitor assembly. Refer to Figure 2.

Push the spacers onto the 7/16" tube and adjust so that the top spacer is approximately 20 inches from the top end of the tube, the bottom spacer is near the bottom end of the tube and the remaining spacer is half-way between the other two. Push the rain cap onto the top of this tube and then slide this assembly into the 1" x 45" tube. Seat the rain cap over the 1 inch tube. Repeat this instruction for the other capacitor.

DO NOT place the caplug on the 7/16" tube at this time.

Attaching Capacitors to Coil

Loosely assemble two pairs of 1 1/8" x 1" clamps and two pairs of 1 1/8" x 7/16" clamps as shown in Details B and C of Figure 2.

Select the 80/40 meter coil assembly (Item 14) and attach the capacitors to the coil assembly using the clamps as shown in Figure 2. Dimensions A and B will be set later on in the instructions.

NOTE: All clamps should be placed flush with the coil form edge and touching each other. The rain caps should be pushed completely on each 1" tube, and should be flush with the 1 1/8" x 7/16" clamp. Tighten the hardware on these four pairs of clamps. Place the caplug on the top end of each 7/16" tube.

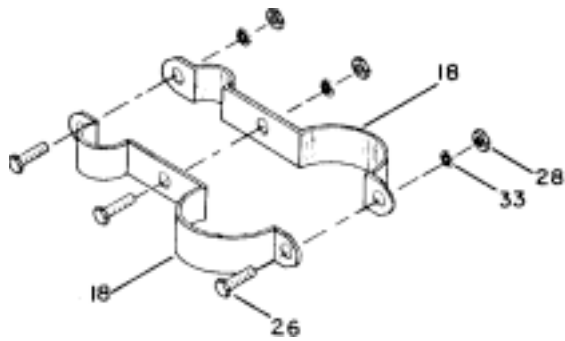

Detail B

1 1/8" x 7/16" Mast/Capacitor Clamp

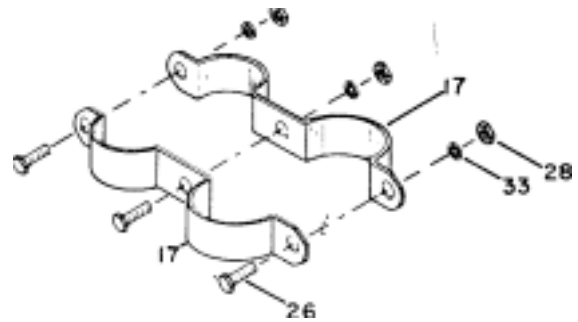

Detail C

1 1/8" x 1" Mast/Capacitor Clamp

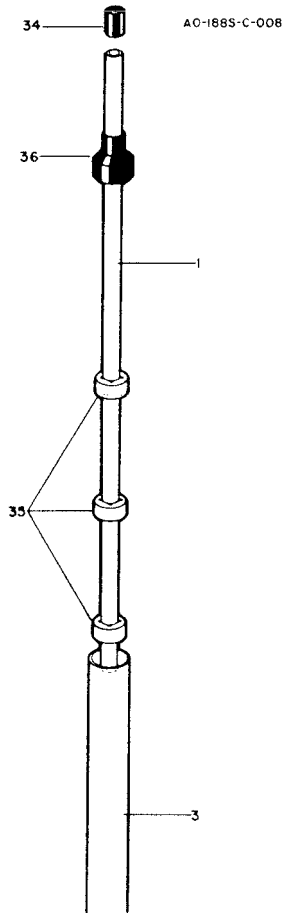

Detail A

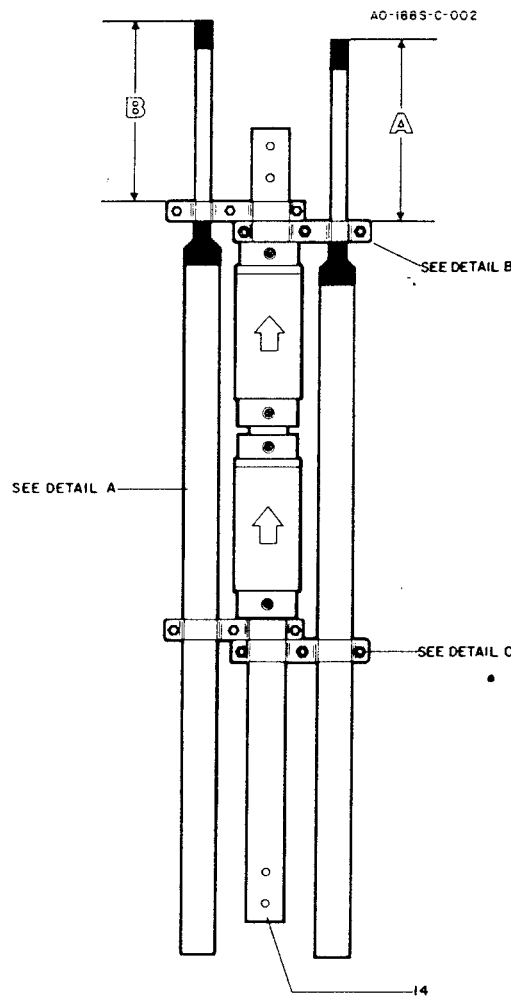

Item No.	Description
1	Tube, 7/16" x 48"
3	Tube, 1" x 45"
14	Coil Assembly, 80/40 Meters
17	Clamp, Mast/Capacitor, 1 1/8" x 1"
18	Clamp, Mast/Capacitor, 1 1/8" x 7/16"
26	Bolt, #10-24 x 1/2", hex head, stainless steel

Item No.	Description
28	Nut, 10-24, hex, stainless steel
33	Lockwasher, #10, internal, stainless steel
34	Caplug, 7/16" Black
35	Insulator, 7/16" x 7/8" spacer
36	Rain Cap, 1"

Figure 2
80/40 Meter Assembly

10/12/15 METER TRAP

Capacitor

There is one 16 inch capacitor and two 13 inch capacitors used in the 10, 12, and 15 meter trap assembly.

Select one 1" x 16" tube (Item 4), 7/16" x 19" tube (Item 8), 3 spacers (Item 35), 1 rain cap (Item 36), and 1 caplug (Item 34).

Push the spacers onto the 7/16" x 19" tube and adjust so that the top spacer is approximately 10 inches from the top end of the tube, and the bottom spacer is near the bottom end of the tube.

The 3rd spacer should be centered between the other two. Push the rain cap onto the top of this tube and then slide this assembly into the 1" x 16" tube. Seat the rain cap over the 1 inch tube.

DO NOT place the caplug on the 7/16" tube at this time.

Select a 1" x 13" tube (Item 5), 7/16" x 16" inch tube (Item 9), 3 spacers (Item 35), 1 rain cap (Item 36) and 1 caplug (Item 34) for each assembly. Assemble the 13 inch capacitors in the same manner as the 16 inch capacitors.

DO NOT place the caplug on the 7/16" tube at this time.

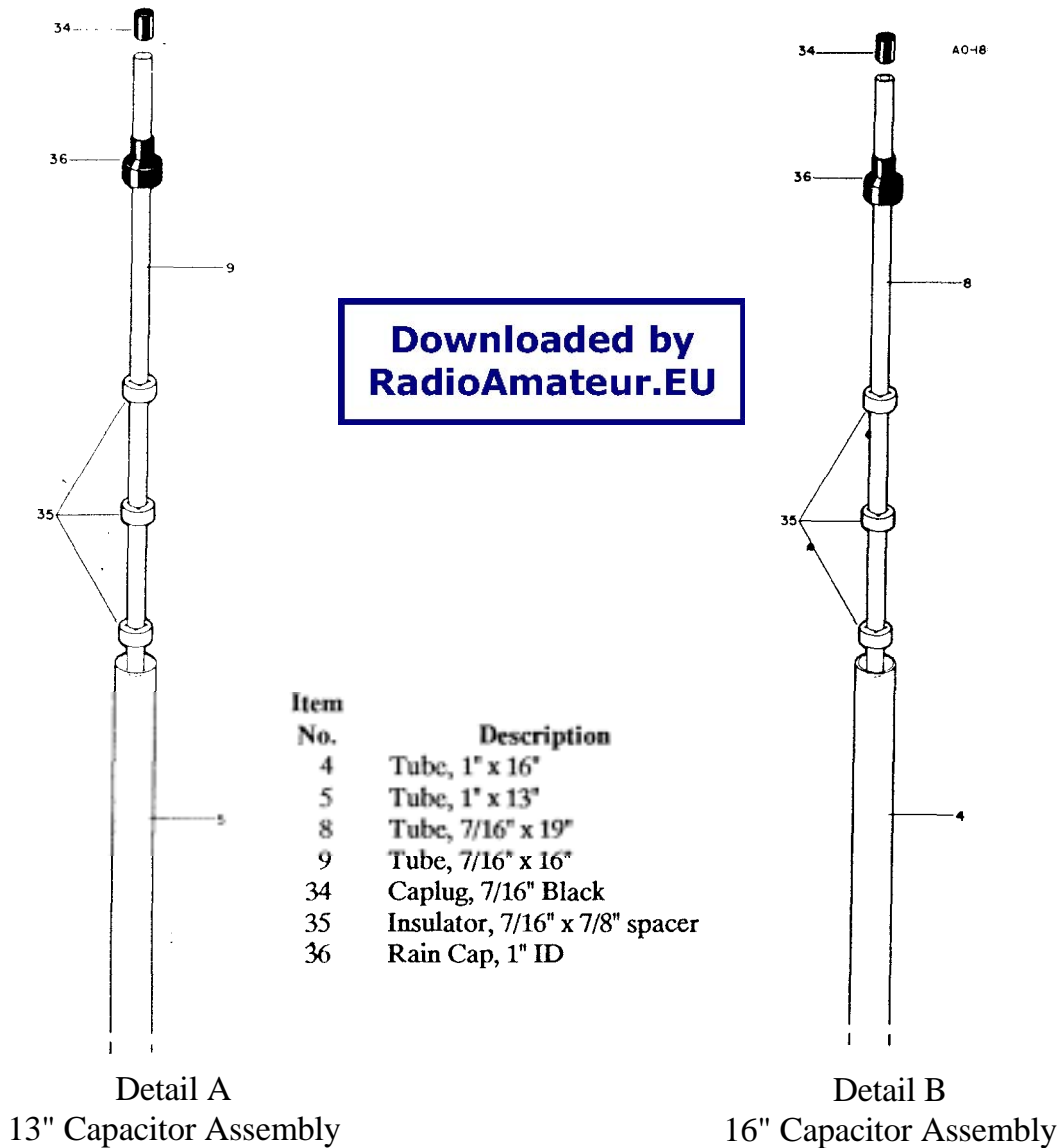

Figure 3

10/12/15 Meter Capacitor Assemblies

Attaching Capacitors to Coil Assembly

Loosely assemble three pairs of 1 1/8" x 1" clamps and three pairs of 1 1/8" x 7/16" clamps as shown in Details A and B of Figure 4.

Select the 10/12/15 meter coil assembly (Item 13) and attach the capacitors onto the coil assembly using the clamps as shown in Figure 4. Dimensions C, D, and E will be set later on in the instructions.

NOTE: Disassembly of clamps may be needed to properly install them onto several inside locations on the 10/12/15 meter trap assembly.

NOTE: The edge of each 1 1/8" x 1" clamp should be flush with the edge of each coil form. The rain caps should be pushed completely on each 1" tube, and should be flush with the 1 1/8" x 7/16" clamp. Tighten the hardware on these 6 pairs of clamps. Push a caplug (Item 34) on the top end of each 7/16" tube.

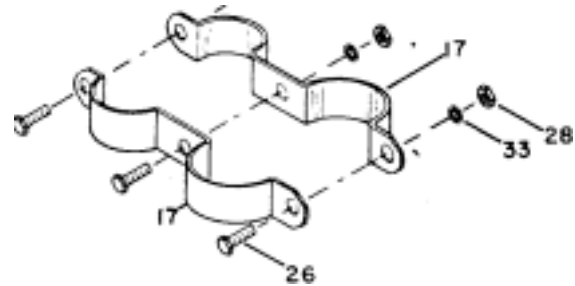

Detail A

1 1/8" x 1" Mast/Capacitor Clamp

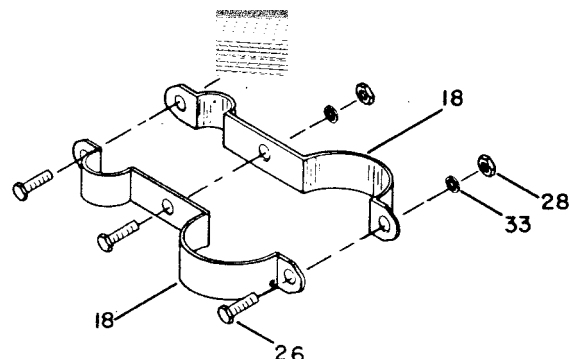

Detail B

1 1/8" x 7/16" Mast/Capacitor Clamp

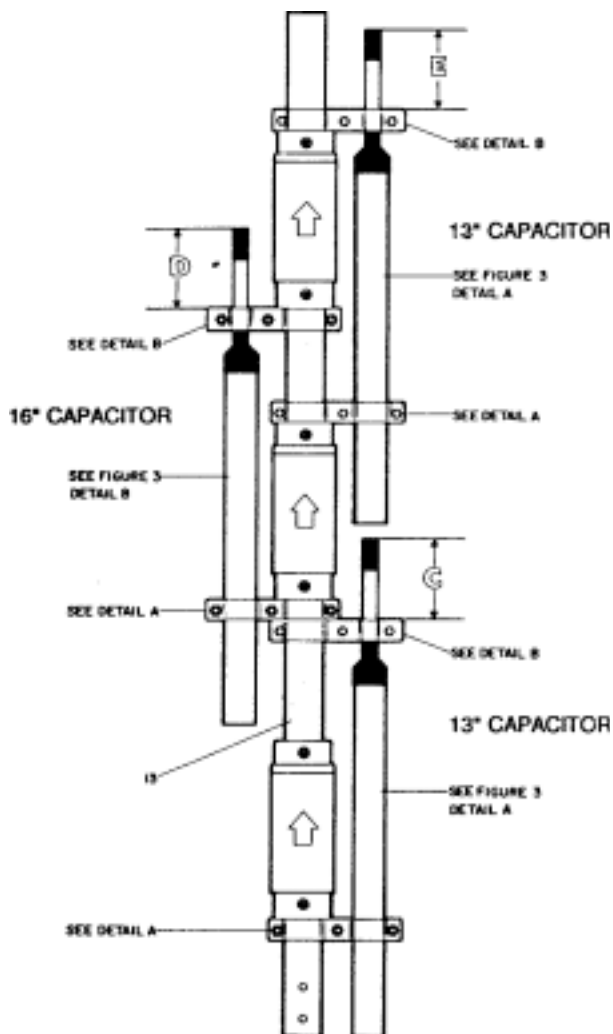

Item No.	Description
13	Coil Assembly, 10/12/15 Meters
17	Clamp, Mast/Capacitor, 1 1/8" x 1"
18	Clamp, Mast/Capacitor, 1 1/8" x 7/16"
26	Bolt, #10-24 x 1/2", hex head, stainless steel
28	Nut, 10-24, hex, stainless steel
33	Lockwasher, #10, internal, stainless steel
34	Caplug, 7/16" Black
35	Insulator, 7/16" x 7/8" spacer
36	Rain Cap, 1" ID

Figure 4
10/12/15 Meter Trap Assembly

17/20 METER ASSEMBLY

Capacitor Assembly

There is one 16 inch capacitor and one 13 inch capacitor used in the 17/20 meter trap assembly.

Select one 1" x 16" tube (Item 4), 7/16" x 19" tube (Item 8), 3 spacers (Item 35), 1 rain cap (Item 36), and 1 caplug (Item 34).

Push the spacers onto the 7/16" x 19" tube and adjust so that the top spacer is approximately 10 inches from the top end of the tube, and the bottom spacer is near the bottom end of the tube.

The 3rd spacer should be centered between the other two. Push the rain cap onto the top of this tube and then slide this assembly into the 1" x 16" tube. Seat the rain cap over the 1 inch tube.

DO NOT place the caplug on the 7/16" tube at this time.

Select a 1" x 13" tube (Item 5), 7/16" x 16" inch tube (Item 9), 3 spacers (Item 35), 1 rain cap (Item 36) and 1 caplug (Item 34). Assemble the 13 inch capacitor in the same manner as the 16 inch capacitor.

DO NOT place the caplug on the 7/16" tube at this time_

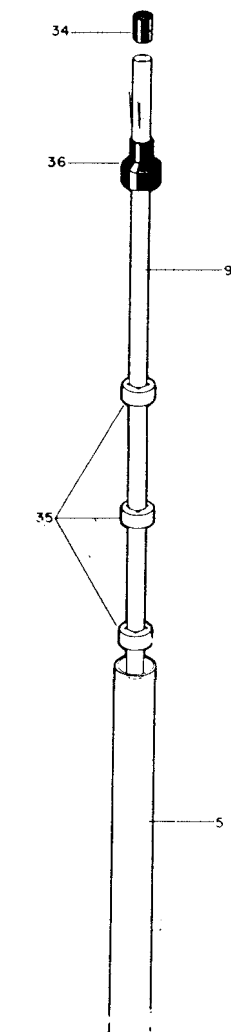

Detail A
13" Capacitor Assembly

Item No.	Description
4	Tube, 1" x 16"
5	Tube, 1" x 13"
8	Tube, 7/16" x 19"
9	Tube, 7/16" x 16"
34	Caplug, 7/16" Black
35	Insulator, 7/16" x 7/8" spacer
36	Rain Cap, 1" ID

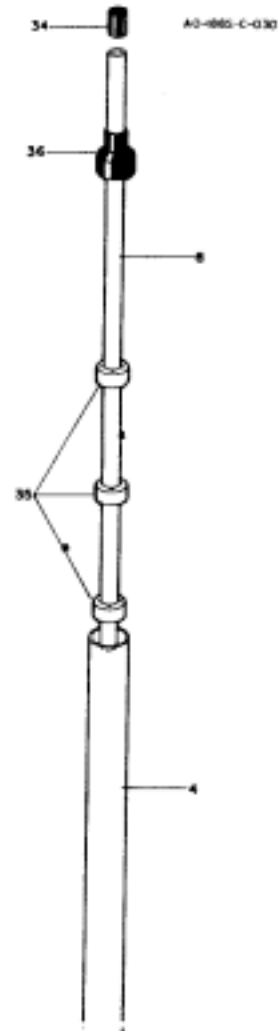

Detail B
16" Capacitor Assembly

Figure 5
17/20 Meter Capacitor Assemblies

Attaching Capacitors to Coil Assembly

Loosely assemble two pairs of 1 1/8" x 1" clamps and two pairs of 1 1/8" x 7/16" clamps as shown in Details A and B of Figure 6.

Select the 17/20 meter coil assembly (Item 12) and attach the capacitors onto the coil assembly using the clamps as shown in Figure 6. Dimensions G, and F will be set later on in the instructions.

NOTE: The edge of each 11/8" x 1" clamp should be flush with the bottom edge of each coil form. The rain caps should be pushed completely on each 1" tube, and should be flush with the 11/8" x 7/16" clamp. Tighten the hardware on these 4 pairs of clamps. Push the ca

Place a large # 16 tubing clamp (Item 23) over the slotted end (top) of this assembly, but, DO NOT tighten at this time.

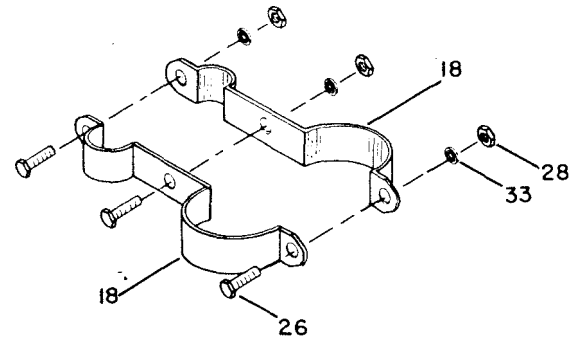
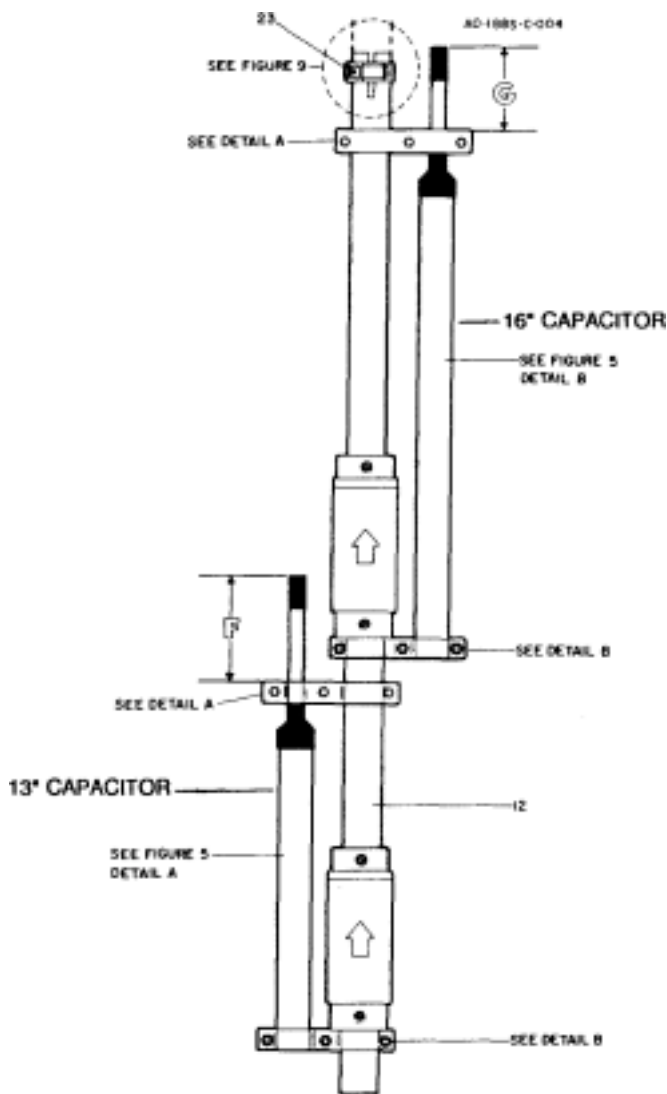

Detail A

11/8" x 7/16" Mast/Capacitor Clamp

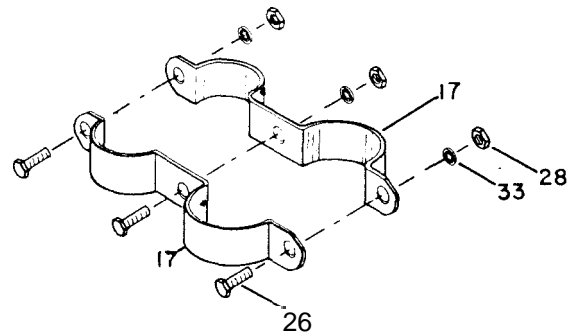

Detail B

1 1/8" x 1" Mast/Capacitor Clamp

Item No.	Description
12	Coil Assembly, 17/20 Meters
17	Clamp, Mast/Capacitor, 1 1/8" x 1"
18	Clamp, Mast/Capacitor, 1 1/8" x 7/16"
23	Clamp, #16 tubing
26	Bolt, #10-24 x 1/2", hex head, ss
28	Nut, 10-24, hex, ss
33	Lockwasher, #10, internal, ss

Figure 6
17/20 Meter Trap Assembly

30 METER TRAP ASSEMBLY

Attaching Capacitors to Coil

Loosely assemble a pair of 1" clamps and a pair of 3/8" x 1" x 3/8" clamps as shown in Details A and B of Figure 7.

Select the 30 meter coil assembly (Item 15) and attach the capacitors onto the coil assembly using the clamps as shown in Figure 7.

NOTE: The edge of each clamp assembly should be flush with each edge of the coil form. Tighten the hardware on these two clamp assemblies.

Place a #10 tubing clamp (Item 22) over the slotted end (top) of this assembly, but, DO NOT tighten at this time. Refer to Figure 9.

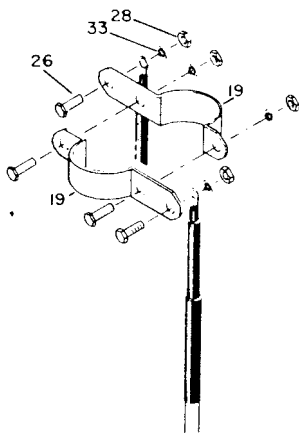
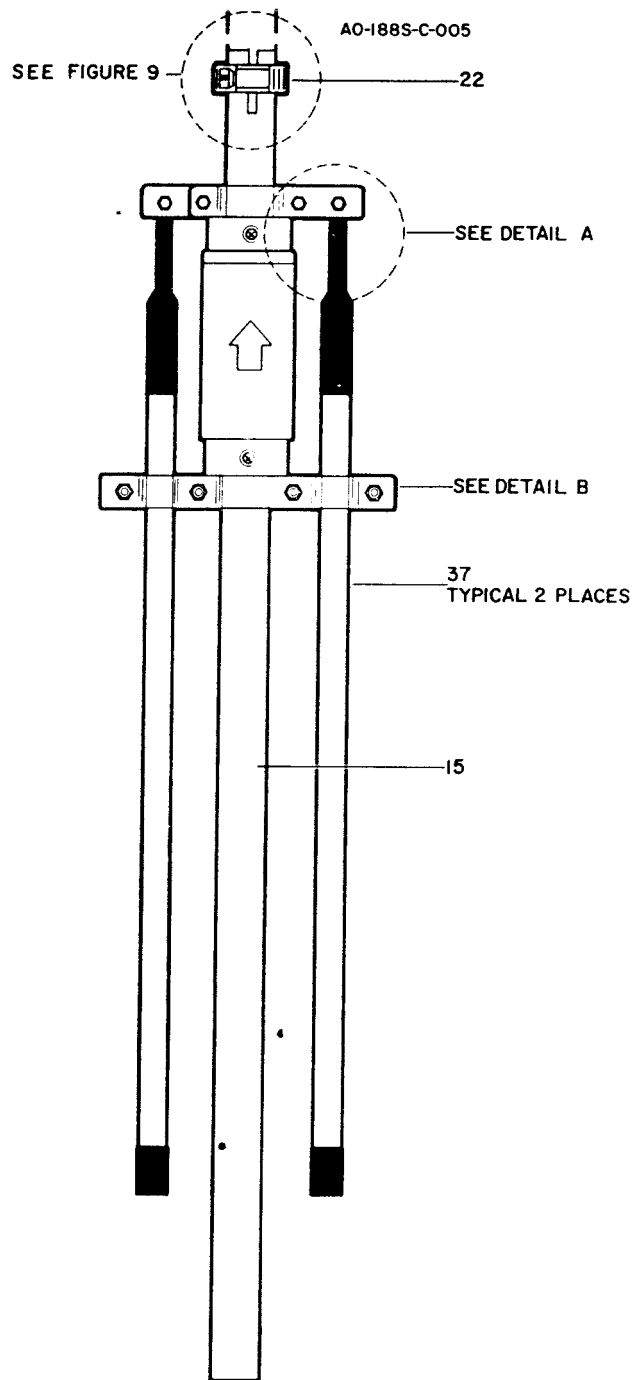

Detail A
1" Mast/Capacitor Clamp

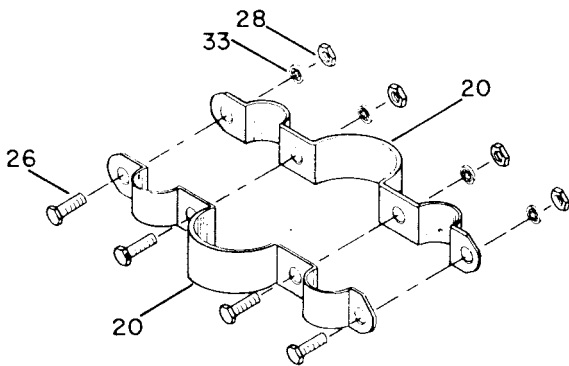

Detail B
3/8" x 1" x 3/8" Mast/Capacitor Clamp

Item No.	Description
15	Coil Assembly, 30 Meter
19	Clamp, Mast/Capacitor, 1"
20	Clamp, Mast/Capacitor, 3/8" x 1" x 3/8"
22	Clamp, #10 Tubing Clamp
26	Bolt, #10-24 x 1/2", hex head, stainless steel
28	Nut, 10-24, hex, stainless steel
33	Lockwasher, #10, internal, stainless steel
37	30 Meter, Capacitor Assembly

Figure 7
30 Meter Trap Assembly

ATTACHING UPPER RADIATOR TUBES TO 30 METER TRAP ASSEMBLY

Select the 30 meter trap assembly, 7/8" x 36" tube (Item 11), 5/8" x 48" tube (Item 10), 7/16" x 55" tube (Item 2), and the two #6 tubing clamps (Item 21). Assemble as shown in Figure 8. Dimensions H and I will be set later on in the instructions. Tighten all hardware and clamps except for the middle tubing clamp.

Push a caplug (Item 34) on the top end of the 55" x 7/16" tube (Item 2).

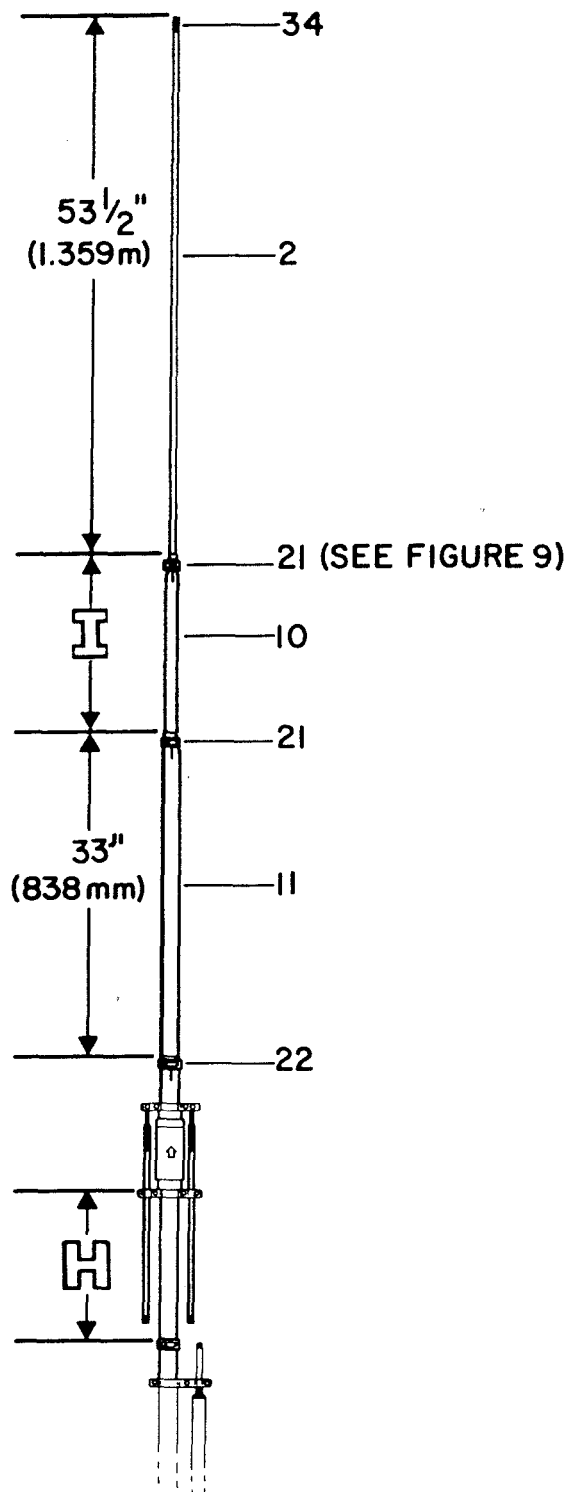

Item No.	Description
2	Tube, 7/16" x 55"
10	Tube, 5/8"-48"
11	Tube, 7/8" x 36"
21	Clamp, #6 Tubing Clamp, ss
22	Clamp, #10 Tubing Clamp, ss
34	Caplug, 7/16" Black

Figure 8
Upper Radiator Tubes Attached to
30 Meter Trap Assembly

INSTALLATION OF TUBING CLAMPS

Select the proper size tubing clamp as shown in the chart. When installing the clamps, place the clamp near the tube end with the top of the clamp over the slot in the tube as shown in Figure 9.

After adjustment of the tubing lengths, tighten the clamp with a 5/16 inch nut driver, socket, or open end wrench until the tubing will not twist or telescope.

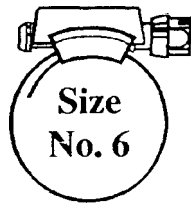
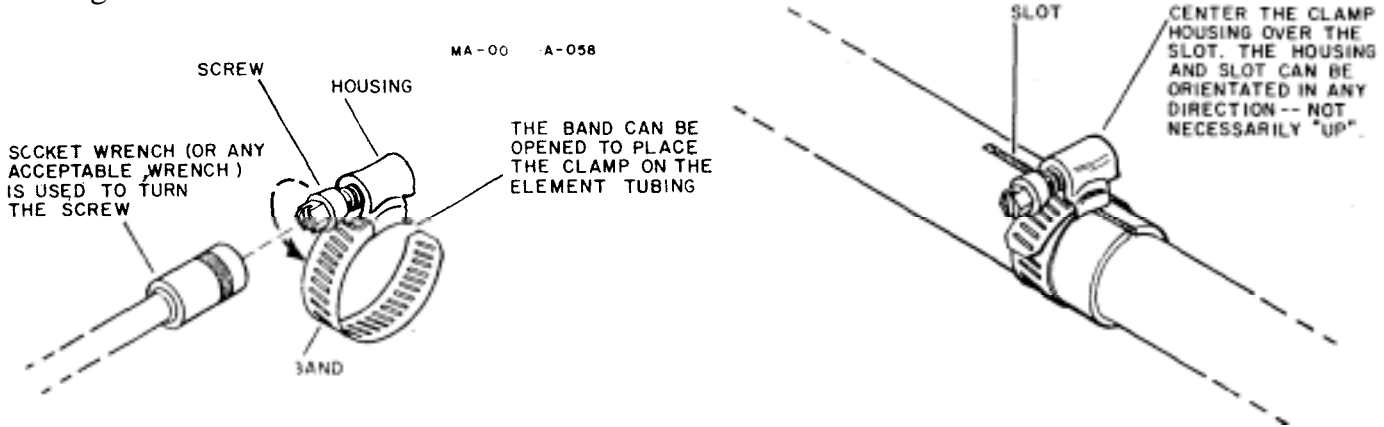

Part No.	Description	Fits Tubing Sizes
358756	Clamp, Size #6 all stainless steel 5/16" hex head screw	1/2 and 3/4"

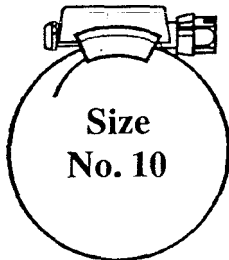

Part No.	Description	Fits Tubing Sizes
358757	Clamp, Size #10 all stainless steel 5/16 hex head screw	1"

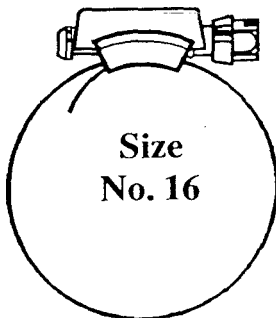

Part No.	Description	Fits Tubing Sizes
358758	Clamp, Size #16 all stainless steel 5/16 hex head screw	1 1/4"

Figure 9
Tubing Clamps

ATTACHING THE TRAP ASSEMBLIES

Slide the bottom end of the 30 meter trap into the top end of the 17/20 meter trap assembly. Dimension H will be set later on in the instructions. DO NOT tighten now.

Select the 1 1/4" x 6 1/4" slotted tube splice (Item 6), and the two #16 tubing clamps (Item 23) . Assemble as shown in Figure 8. The bottom of the 17/20 meter trap assembly and the top of the 10/12/15 meter trap assembly should meet within this tube.

Tighten both tubing clamps securely.

Select the 1 3/8" x 9 3/4" drilled tube splice (Item 7), four # 10-24 x 1 3/4 inch bolts (Item 25), four #10 lockwashers (Item 33), and four # 10-24 hex nuts (Item 28). Assemble this tube as shown to join the bottom of the 10/12/15 meter trap assembly to the top of the 80/40 meter tuning assembly. Tighten all hardware securely.

Select the base assembly and attach to the bottom of the 80/40 meter tuning assembly using two 10-24 x 1 3/4 inch bolts (Item 25), two #10 lockwashers (Item 33), and two # 10-24 hex nuts (Item 28). Tighten all hardware securely.

NOTE: The long 80/40 meter tuning capacitors and the 10 meter capacitor may be loosened and rotated to allow assembly or prevent mechanical interference problems between them and the 10 meter capacitor. Tighten all hardware securely. See top views in Figure 12.

DC SHORTING COIL

The VSWR on the 40 and 80 Meter bands may be improved by the construction and installation of a matching coil. This coil will also provide a DC ground for the antenna, which may help to prevent precipitation static. This coil is included in the GRK-88

A coil consisting of 9 or more turns of No. 12 insulated copper wire should be wrapped on a 1 inch diameter coil form and connected between the radiator and the ground (shunt).

If this antenna is modified to operate on 160 meters, this coil may be replaced with another coil of the proper value.

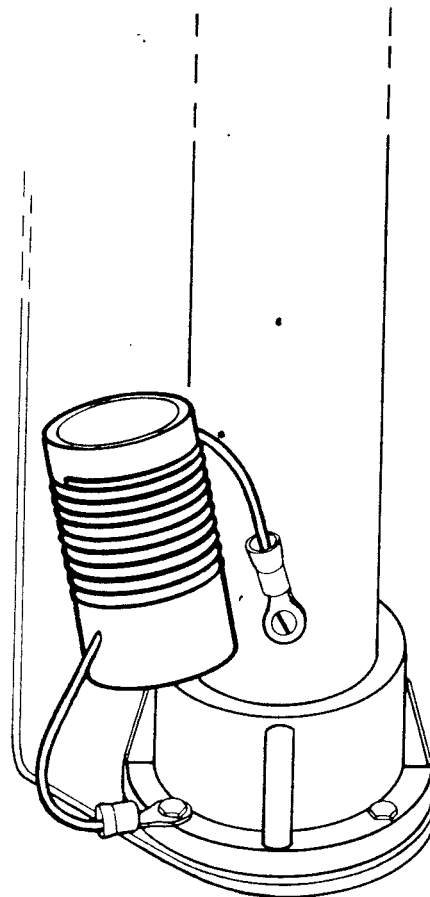

Figure 10
DC Shorting Coil

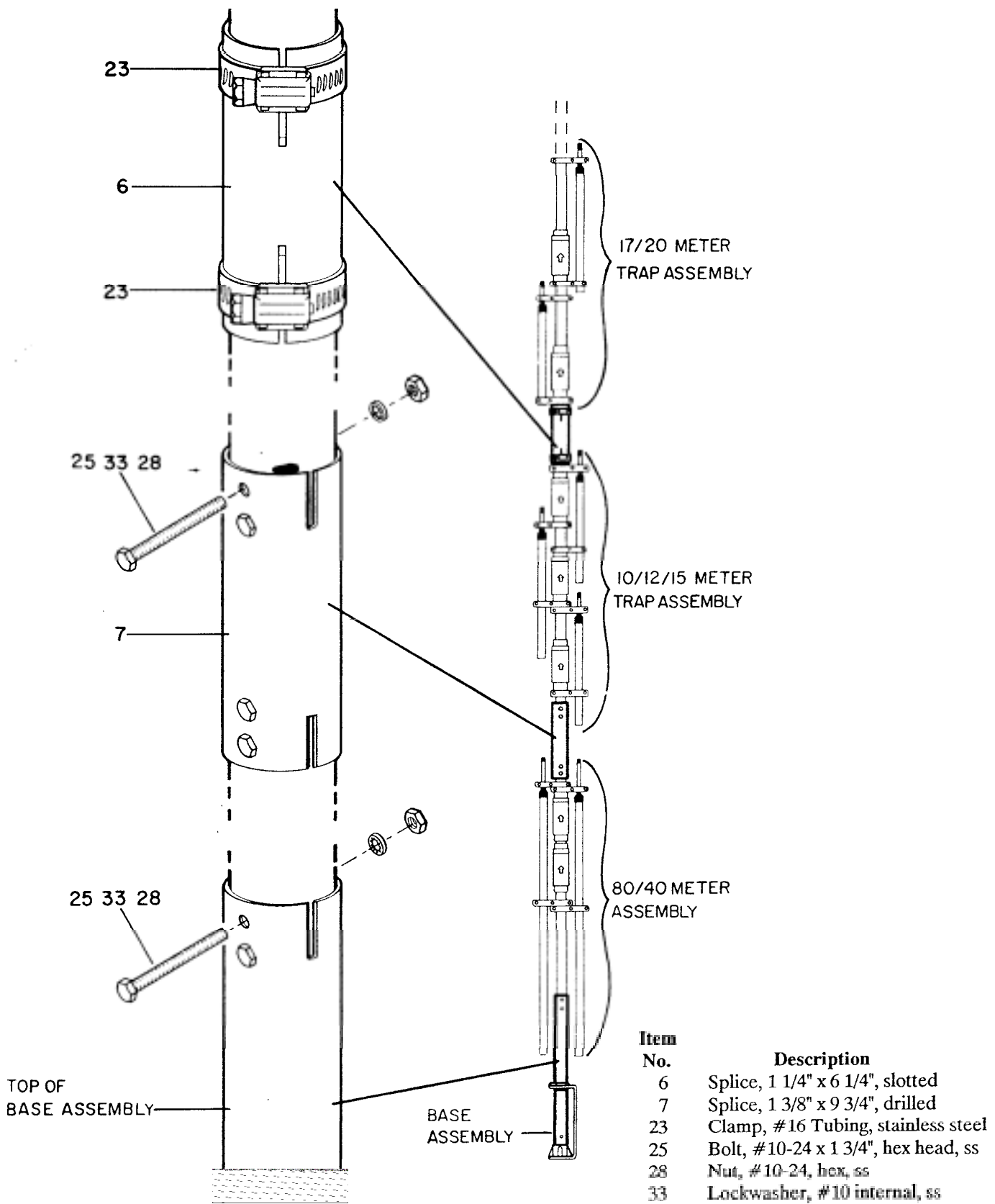

Figure 11
Connecting Trap Assemblies

TUNING THE DX-88

VERTICAL ANTENNA

Decide if you want to tune the DX-88 vertical for the 8 HF amateur bands or whether you wish to tune it for reception on the international shortwave broadcasting bands. Also, if you choose the amateur band settings, you must also choose a setting for either 80 meter CW (3500 - 3800 KHz) or 75 meter "phone" (3700 - 4000 KHz). Although the DX-88 may be tuned from 3500 to 4000 KHz at the base of the antenna, the narrower 40 meter band (7000 - 7300 KHz) tracks along with the same adjustment. The 5/8 inch tubing near the tip of this antenna (dimension I) should be set to 18 inches if you operate mostly on CW on both 40 and 80 meters. Dimension I should be set to 28 inches if you operate mostly on phone on both 40 and 80 meters.

If you wish to use a tuner or matchbox to cover all of the 80 meter band, choose either the CW or phone setting and tune the long capacitors to favor the right part of the 40 meter band. You may then switch the tuner to the "thru" setting for 40-10 meters.

You may install the DX-88 on the ground, on a rooftop or on a mast. If installed on the ground, the supplied dimensions will be accurate only if the GRK-88 ground radial kit is used, or if a radial system is constructed identical to the GRK-88. Each of the bands, 30 meters through 10 meters, may be tuned individually to favor a particular part of each band. On 30 meters, dimension H may be lengthened to lower the resonance or shortened to raise the resonance on each band. On the other bands, more capacitance (tubing pushed in) will lower the resonance, and less capacitance (tubing pulled out) will raise the resonance.

If installed on a rooftop, the supplied dimensions will be accurate only if the RRK-88 roof radial kit is used or if a radial system is constructed identical to the RRK-88. Each of the bands, 30 meters through 10 meters, may be tuned individually as described previously. Also, each band may be tuned by adjusting the lengths of the corresponding radials.

This may be easier to achieve on some roof tops. Mast mounting is the same as roof top mounting.

A radial system is always required with this antenna. The only exception might be when the antenna is installed on a saltwater beach with a ground rod.

If you choose to tune the DX-88 for SWL operation, you may optimize the antenna for 8 bands. Other bands of frequencies may still be received by this antenna, but at reduced signal strengths. Adjust dimensions A through T according to these tables and graphs or from the dimensions supplied in the examples. See Figure 12.

EXAMPLE I - Amateur

The dimensions for this antenna to resonate in the center of each amateur band are:

- A = 10"
- B = 10"
- C = 3 1/2"
- D = 2 1/8"
- E = 1 3/4"
- F = 2 1/2"
- G = 3"
- H = 16"
- I = 18"

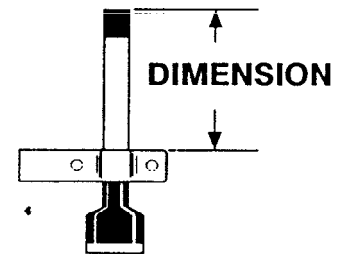

EXAMPLE 2 - SWL

The dimensions for this antenna to resonate in the center of the 11, 13, 16, 19, and 31 meter SWL bands, and near the 49 and 90 meter SWL bands are:

- A = 1 3/4"
- B = 1 3/4"
- C = (See Graph)
- D = 4"
- E = 3"
- F = 1 3/4"
- G = 7"
- H = 25"
- I = 46"

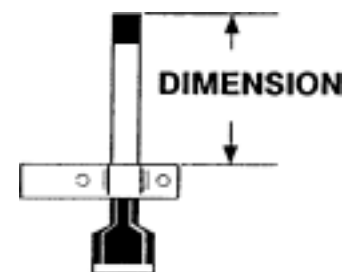

30 Meter bracket = at bottom of 30 meter capacitors.

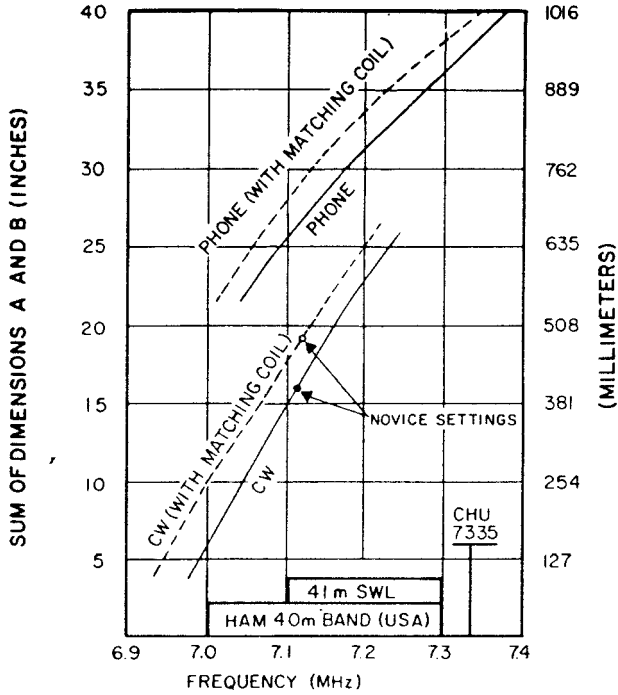

Graph 1

Sum of Dimension A and B
80/40 Meter Trap for 6.9-7.4 MHz

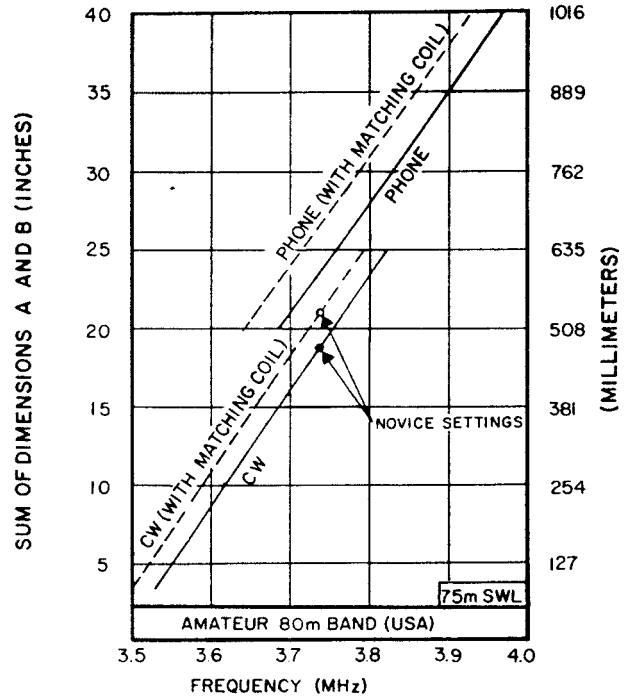

Graph 2

Sum of Dimension A and B
80/40 Meter Trap for 3.5-4.0 MHz

**Downloaded by
RadioAmateur.EU**

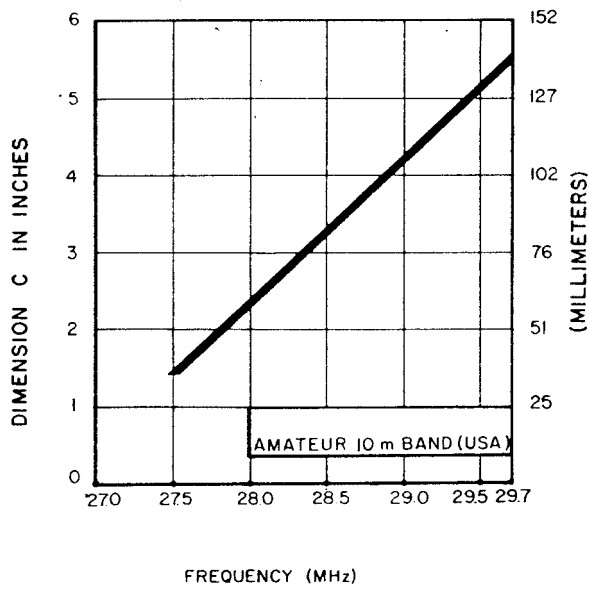

Graph 3

Dimension C
10 Meter Trap for 27-29.7 MHz

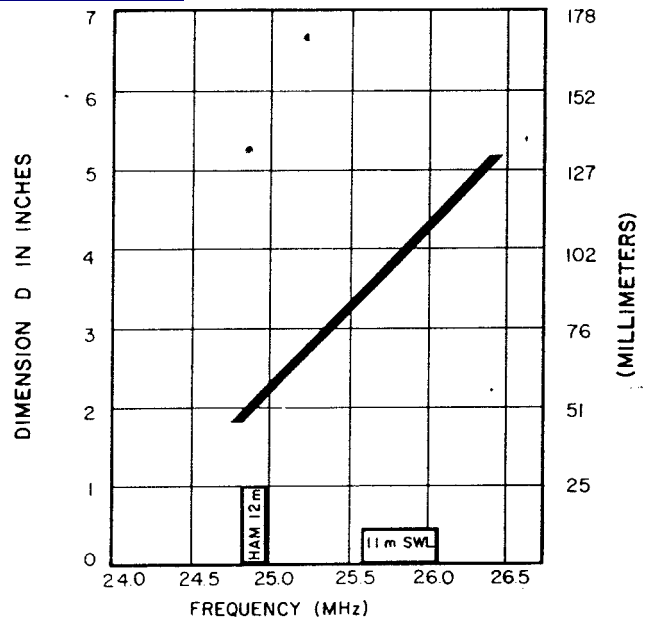

Graph 4

Dimension D
12 Meter Trap for 245-26.5 MHz

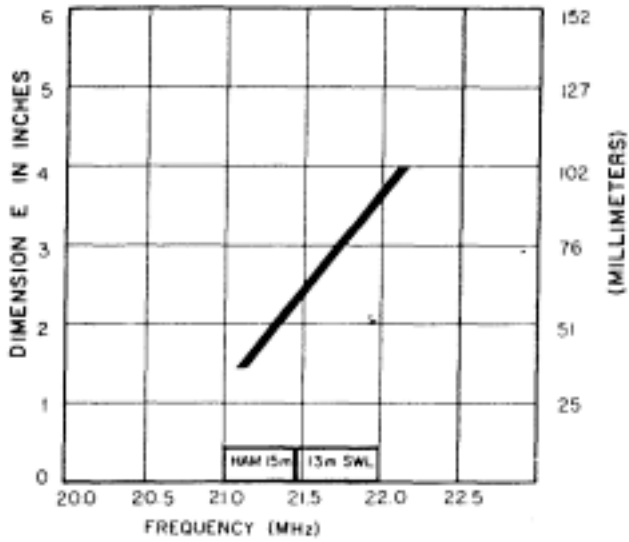

Graph 5
Dimension E
15 Meter Trap for 20.5-22 MHz

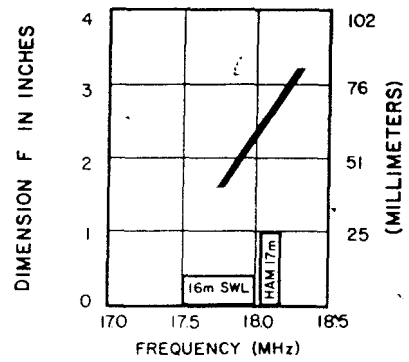

Graph 6
Dimension F
17 Meter Trap for 17.5-18.5 MHz

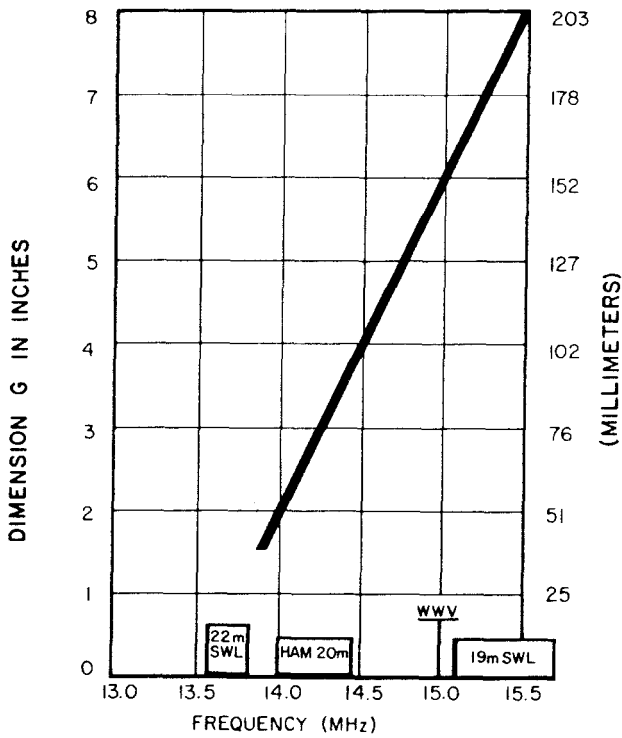

Graph 7
Dimension G
20 Meter Trap for 13.5-15.5 MHz

NOTE: THE "SWL" CURVE FOR THIS FREQUENCY RANGE IS OBTAINED BY SLIDING THE 3/8" X 1" X 3/8" CLAMP ASSEMBLY TO THE BOTTOM OF THE 30 METER CAPACITORS, AND RETIGHTENING.

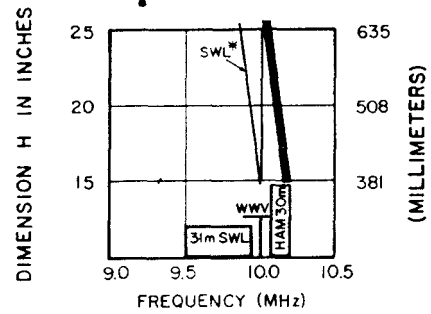

Graph 8
Dimension H
30 Meter Trap for 9.5-10.5 MHz

SETTING	DIMENSION "H"	DIMENSION "I"
HAM - CW	16 in.	18 in.
HAM-PHONE AND S WL 41/75 METERS	19 in.	28 in.
S WL 49/90 METERS	25 in.	46 in.

Table 1
Dimension H and I for HAM
and SWL Settings

The following high frequency bands have been allocated by the International Telecommunication Union to be used for broadcasting:

kiloHertz	MegaHertz Band	Meter Band
2,300-2,495	2	120*
3,200-3,400	3	90*
3,900-4,000	4	75**
4,750-5060	5	60*
5,900-6,200*	6	49t
7,100-7,350*	7	411#
9,400-9,775*	9	31r-*
9,775-9,900	9	31\$
11,600-11,700*	11	25v
11,700-11,975	11	251'
11,975-12,100*	11	25t
13,570-13,870*	13	22\$
15,100-15,450	15	19t
15,450-15,800*	15	19f
17,480-17,700*	17	16v
17,700-17,900	17	16t
18,900-19,020*	19	16t
21,450-21,750	21	13t
21,750-21,850	21	13\$
25,600-26,100	26	lit

- Tropical bands, for broadcasting use in designated tropical areas.
- ** Regional band used only in Europe and Asia.

World Bands, used worldwide.

World Band extensions. Not yet officially authorized, but being used by an increasing number of broadcasting stations.

Not used for broadcasting in the Western Hemisphere.

Includes Amendments to Article 8, The Int. Table of Frequency Allocations, effective April 1, 2007.

Many stations use frequencies outside of, but adjacent to the bands listed above.

Table 2
Broadcasting Frequencies

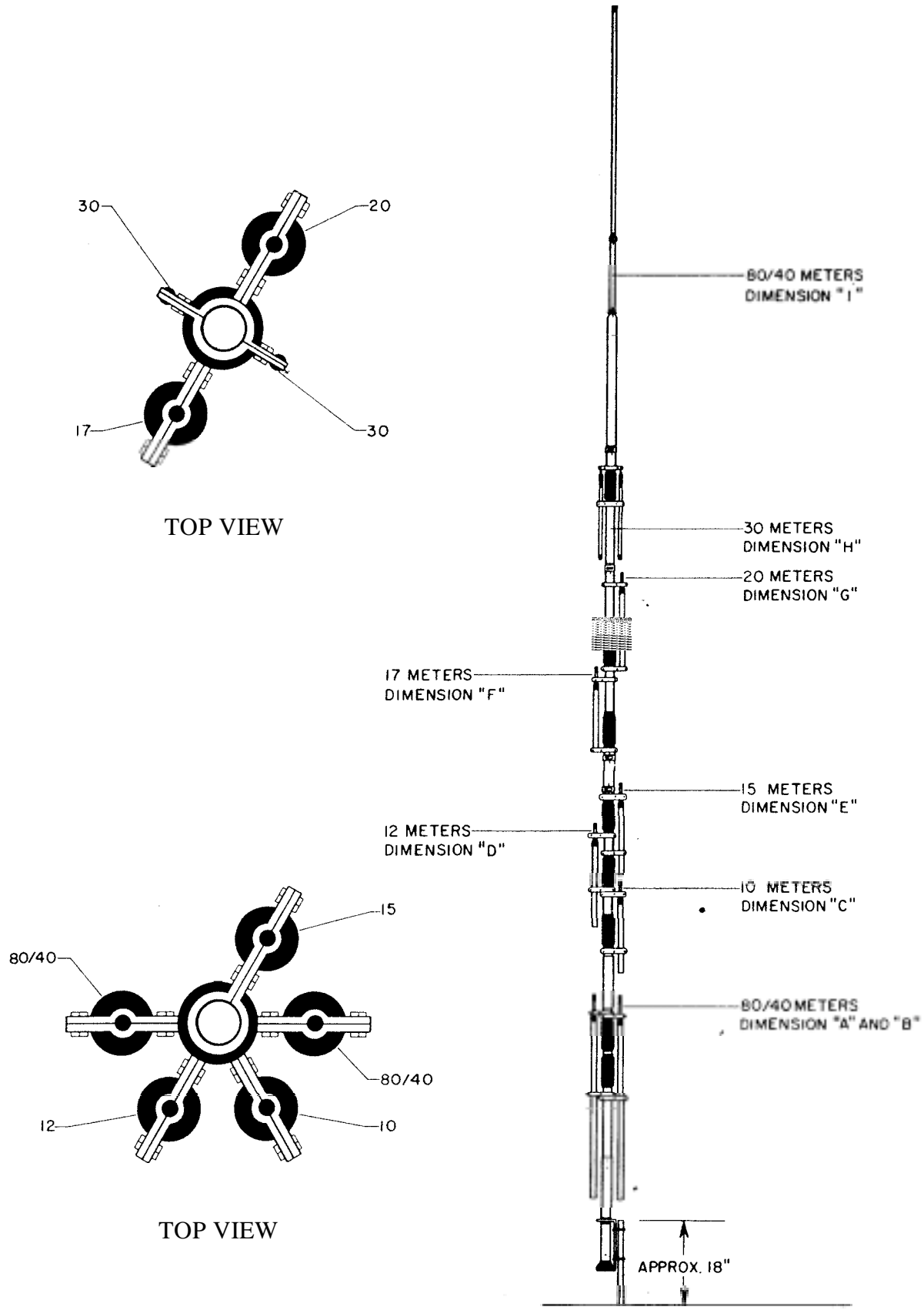

Figure 12
DX-88 Overall View

CHAPTER 4

MOUNTING THE ANTENNA

The Omni DX-88 vertical can be mounted on the ground, on a rooftop or on a mast. For best performance, it should be mounted in the clear, at least 20 feet from buildings, metal fences, metal masts or flag poles and other metallic structures.

WARNING

Installation of this product near power lines is dangerous! For your safety, follow the installation directions.

DO NOT install this antenna near any power lines. Not only is it dangerous to put up and take down, the power lines could cause excessive noise to be received by the radio connected to this antenna.

If the DX-88 is installed on the ground, a radial system is normally required. The minimum recommended radial system consists of 16 radials, each 14 feet (4.3 m) long. See Figure 13.

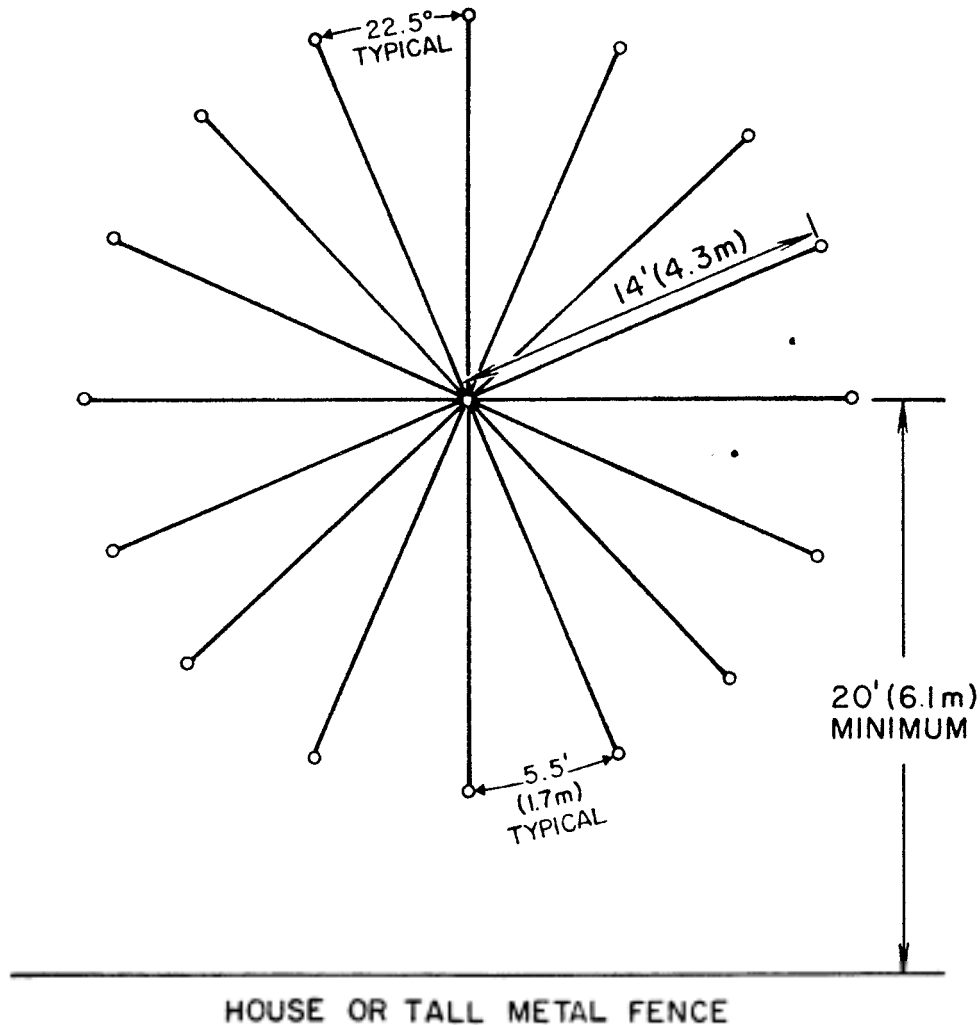

Figure 13
DX-88 Ground Mount Radial System

Since the radials of a ground-mounted vertical are actually on, if not in, the ground, they are coupled by capacitance or conduction to the ground, and thus resonance effects are not important. Basically, the function of ground radials is to provide a low-loss return path for ground currents. Longer radials and more radials will reduce the ground losses and effectively increase the gain of the antenna. See the article entitled "Radial Systems for Ground-Mounted Vertical Antennas" by Brian Edward, pages 2830, QST magazine, June, 1985 for more information.

It is recommended to use copper wire or copperweld wire for the radials. The Hy-Gain ground radial kit, model GRK-88 uses 7/23 Copperweld® wire. The wires may be soldered to lugs and attached to the bottom of the base bracket.

If the DX-88 vertical is installed on a garage or house roof, a resonant radial system must be used. The Hy-Gain model RRK-88 roof radial kit may be used or you may construct a radial system identical to it. See Figures 14 and 15.

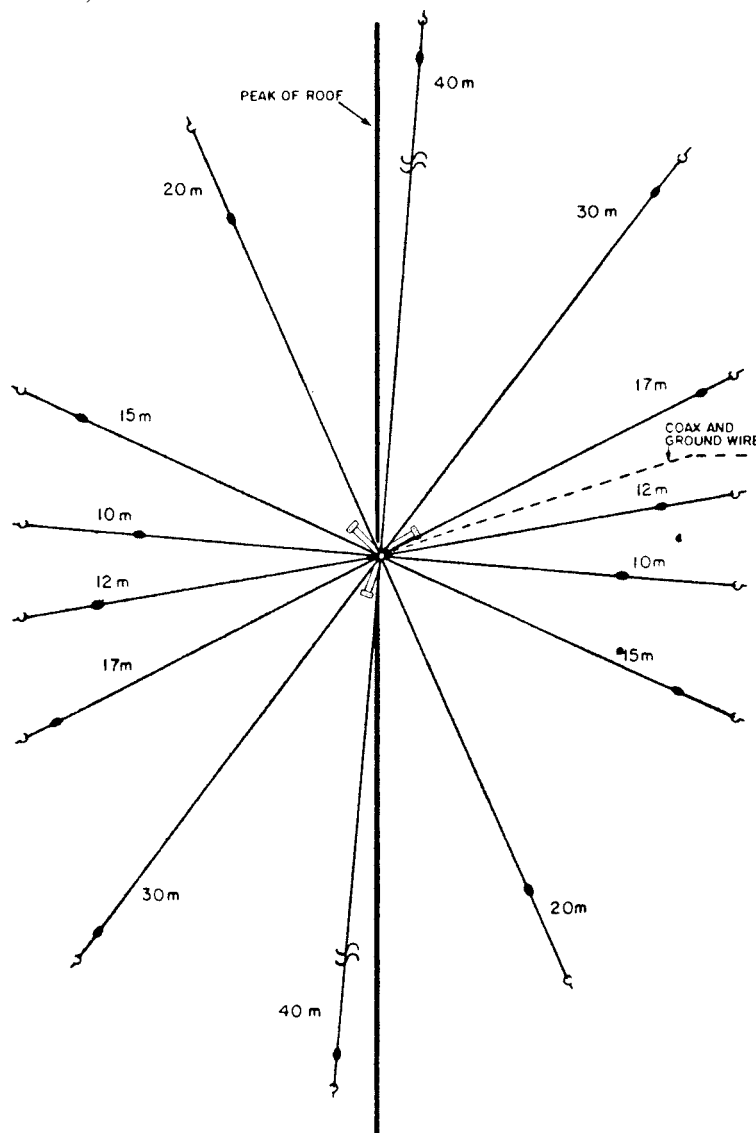

Figure 14
DX-88 Resonant Radial System

RESONANT RADIAL LENGTHS					
AMATEUR BAND	WIRE LENGTH		SWL BAND	WIRE LENGTH	
(METERS)	U.S.	METRIC	(METERS)	U.S.	METRIC
41/40	34'2"	10.41 m	31	25'1"	7.65 m
30	23'9"	7.24 m	22	17'10"	5.43 m
20	17'1"	5.21 m	19	16'0"	4.87 m
17	13'8"	4.17 m	16	13' 10"	4.23 m
15	11'11"	3.63 m	13	11'5"	3.47 m
12	10'3"	3.12 m	11	9'7"	2.92 m
10	9' 1"	2.77 m			

Table 3
Resonant Radial Lengths

NOTE:

The radial wire lengths may be adjusted longer or shorter to fine-tune the resonant frequency on each band

**Downloaded by
RadioAmateur.EU**

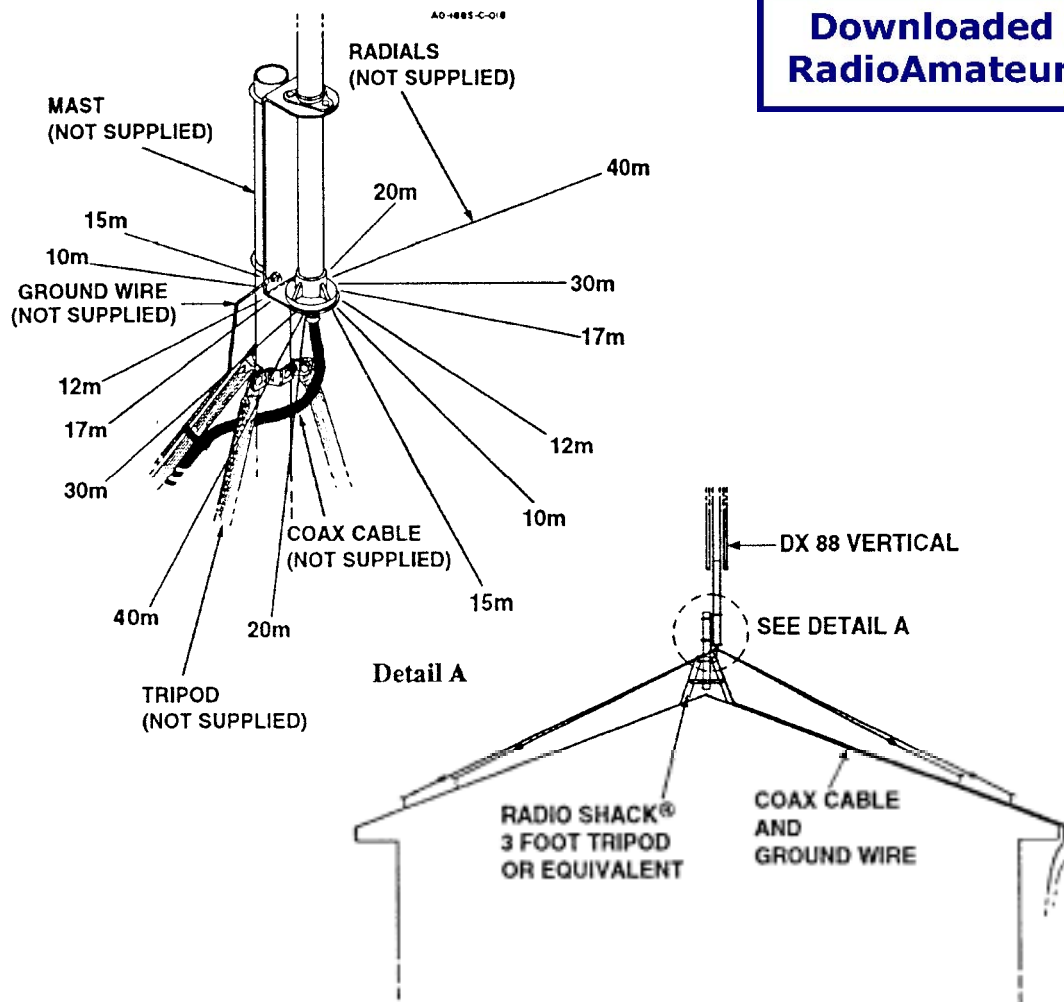

Figure 15
Roof Mounted Radial System

WARNING

Keep this antenna away from the reach of children or pets. When transmitting, the antenna and antenna radials are hot with RF proportional to the operating power.

If you mount your antenna on a roof and find the roof space is too small for the radial system, you can droop the radials over the edge of the roof at almost any angle without seriously changing the performance of the antenna. The radial system must be insulated from the roof and connected to a good ground for lightning protection. The resonant radials must be at least 10 feet from tower guy wires, mast guy wires or any other wires or metal objects. Use the shortest path possible between the antenna and an 8 foot ground rod for the earth ground, using #6 or #8 copper wire. Mast mounting is identical to roof mounting.

In any installation, use a good quality 50 ohm coaxial transmission line such as Times RG-213/u (solid), Belden 8214 (foam) or Belden 8237, 8267 or 9251 (solid).

Take extra care when soldering connectors to foam dielectric coaxial cable. Weatherproof all connectors which will be exposed to rain or ice with Coax-Seal or another similar substance.

Attach the transmission line to the bottom of the base assembly and tighten securely. Tape the coax to the tripod for strain relief when roof mounting. Bury the coax, when ground mounting, for protection from lawn mowers.

CAUTION: Align the bottom tube of the DX-88 antenna parallel to your support mast before tightening. Your support mast must be 1 1/2" - 1 5/8" (38-41 mm) O.D. Tighten the U-bolts securely using open-end wrenches! If one U-bolt is loose, the bracket will twist.

OPERATION

Connect the other end of your transmission line to a good quality SWR meter and then to your transmitter. While using low power (less than 200 watts output) check the VSWR across each band from 3.5 to 29.7 MHz. Record this information for future reference. See Table 4. Check the VSWR periodically to ensure proper operation.

This completes your installation of the Omni DX-88.

Service Information

If you are unable to resolve your problem or if you need to order replacement parts, you should contact the Hy-Gain Customer Service Department.

You should fully research your problem by going through the Troubleshooting Guides in Chapter 6 before you contact the Customer Service Department. You should also record your VSWR across all three bands before calling

You should retain your sales receipt or other proof of purchase for antennas that are still under warranty.

All requests, inquiries, warranty claims, or for ordering replacement parts, contact:

Hy-Gain

308 Industrial Park Road
Starkville, Mississippi
39759 USA

Phone: 662-323-9538

FAX: 662-323-6551

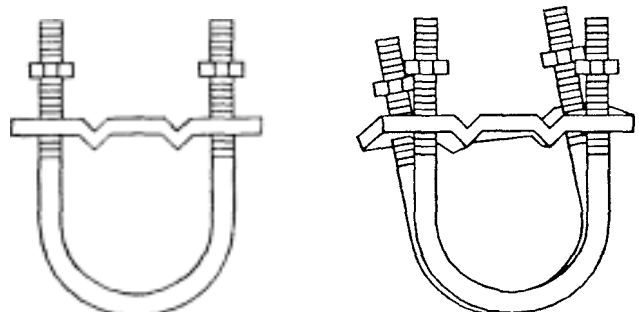

RIGHT

WRONG

VSWR RECORD

Type of VSWR Meter	Date_____	Date_____	Date_____
Frequency	VSWR	VSWR	VSWR
3.			
7.000			
7.150			
7.300			
10.100			
10.150			
14.000			
14.200			
14.350			
18.068			
18.168			
21.000			
21.250			
21.450			
24.890			
24.990			
28.000			
28.400			
28.800			
29.600			

CHAPTER 5

PARTS LIST

Item

1	174865	Tube, 7/16" x 48"	2
2	174939	Tube, 7/16" x 55"	1
3	179764	Tube, 1" x 45"	2
4	179767	Tube, 1" x 16"	2
5	179768	Tube, 1" x 13"	3
6	179771	Splice, 11/4" x 6 1/4", slotted	1
7	179772	Splice, 13/8" x 9 3/4", drilled.....	1
8	179782	Tube, 7/16" x 19"	2
9	179783	Tube, 7/16" x 16".....	3
1	190000	Tube, 5/8" x 48", swaged	1
1	190210	Tube, 7/8 x 36", swaged.....	1
1	878202	Coil Assembly, 17/20 Meter	1
1	878204	Coil Assembly, 10/12/15 Meter.....	1
1	878532	Coil Assembly, 80/40 Meter	1
1	878536	Coil Assembly, 30 Meter.....	1
1	878537	Base Assembly.....	1
	878539		
1	179734	Clamp, Mast/Capacitor, 11/8" x 1.....	14
1	179735	Clamp, Mast/Capacitor, 11/8" x 7/16".....	14
1	179736	Clamp, Mast/Capacitor, 1"	2
2	179737	Clamp, Mast/Capacitor, 3/8" x 1" x 3/8".....	2
2	358756	Clamp, #6 Tubing, stainless steel	2
2	358757	Clamp, #10 Tubing, stainless steel.....	1
2	358758	Clamp, # 16 Tubing, stainless steel.....	3
2	543792	U-bolt, 5/16" x 15/8" x 2 1/4"	2
	878541	Parts Pack, DX88 Hardware	1
2	500321	Bolt, # 10-24 x 13/4", hex head, stainless steel	6
2	500158	Bolt, # 10-24 x 1/2", hex head, stainless steel	50
2	505266	Bolt, 1/4"-20 x 3/4", hex head, stainless steel	3
2	554071	Nut, #10-24, hex, stainless steel	56
2	554099	Nut, 1/4"-20, hex	3
3	555747	Nut, 5/16"-18, hex, stainless steel.....	4
3	562961	Lockwasher, 1/4", internal, stainless steel	3
3	564792	Lockwasher, 5/16", split, stainless steel.....	4
3	565697	Lockwasher, #10, internal, stainless steel.....	56
	878542	Parts Pack DX88, Insulators.....	1
3	455644	Caplug, 7/16", black	9
3	460367	Insulator, 7/16" x 7/8", spacer.....	21
3	460368	Rain Cap, 1,, ID	7
3	878548	Capacitor Assembly, 30 Meters	2

hy-gain® LIMITED WARRANTY

Hy-Gain Warrants to the original owner of this product, if manufactured by **Hy-Gain** and purchased from an authorized dealer or directly from **Hy-Gain** to be free from defects in material and workmanship for a period of 12 months for rotator products and 24 months for antenna products from date of purchase provided the following terms of this warranty are satisfied.

1. The purchaser must retain the dated proof-of-purchase (bill of sale, canceled check, credit card or money order receipt, etc.) describing the product to establish the validity of the warranty claim and submit the original or machine reproduction of such proof of-purchase to **Hy-Gain** at the time of warranty service. **Hy-Gain** shall have the discretion to deny warranty without dated proof-of-purchase. Any evidence of alteration, erasure, or forgery shall be cause to void any and all warranty terms immediately.
2. **Hy-Gain** agrees to repair or replace at **Hy-Gain's** option without charge to the original owner any defective product under warranty, provided the product is returned postage prepaid to **Hy-Gain** with a personal check, cashiers check, or money order for \$8.00 covering postage and handling.
3. Under no circumstances is **Hy-Gain** liable for consequential damages to person or property by the use of any **Hy-Gain** products.
4. Out-of-warranty Service: **Hy-Gain** will repair any out-of-warranty product provided the unit is shipped prepaid. All repaired units will be shipped COD to the owner. Repair charges will be added to the COD fee unless other arrangements are made.
5. This warranty is given in lieu of any other warranty expressed or implied.
6. **Hy-Gain** reserves the right to make changes or improvements in design or manufacture without incurring any obligation to install such changes upon any of the products previously manufactured.
7. All **Hy-Gain** products to be serviced in-warranty or out-of-warranty should be addressed to **hy-gain, 308 Industrial Park Road, Mississippi 39759, USA** and must be accompanied by a letter describing the problem in detail along with a copy of your dated proof-of-purchase.
8. This warranty gives you specific rights, and you may also have other rights which vary from state to state.