

INSTRUCTION MANUAL

ORDER NO. 221**Model TH3JR
Thunderbird Junior**

PN 801221

General Description

The TH3JR antenna was designed for the Ham who has space limitations but still wants top performance on 10, 15 and 20 meters. The TH3JR is constructed of taper-swaged aluminum tubing which offers low wind resistance. It can be rotated with a heavy-duty TV rotator. The light weight is ideal for rooftop or lightweight tower installations. The antenna features a new trap design, hardware that is irridite treated to Military Specifications and molded high-impact insulators.

"Warning installation of this product near powerlines is dangerous. For your safety, follow the installation directions."

Specifications*Electrical*

Forward Gain	up to 8 dB
Front-to-Back Ratio	25 dB
VSWR at Resonance	less than 1.5:1
Nominal Impedance	50 ohms
Power Capability (Transmitter Output)	600w P.E.P., 300w AM
Lightning Protection	DC ground

Mechanical

Net Weight	21 lbs. (11.778 kg)
Boom Length	12 ft. (3.65 m)
Longest Element	24'2" (7.92 m)
Turning Radius	14'9" (4.49 m)
Wind Survival	80 mph (128.72 kmph)
Accepts Mast	1¼" to 1½" (3.17 to 4.12 cm)
Surface Area	8.35 sq. ft. (0.311 sq. m)
Wind Load at 80 mph	87 lb. (39.46 kmph)

**Step-by-Step
Assembly**

NOTE: When unpacking your antenna, check the inside of all tubing for parts (clamps, insulators, smaller tubing, etc.). To conserve space, these smaller articles are put inside large pieces.

() Select the two boom section (1¼" x 72") and the boom-to-mast brackets.

NOTE: The reflector portion of the boom has holes drilled in it for the beta match. Make sure they are on top when you tighten the boom-to-mast bracket. See illustration in this manual.

() Assemble the two halves of the boom-to-mast bracket by placing the ½" x ¾" screws in the four outside holes as shown in Figure 1. *Do not tighten at this time.*

() Slip the boom sections into the boom-to-mast bracket until they meet in the middle. Make certain the drilled holes on the reflector end are on top and close to the boom-to-mast bracket, then tighten the bolts securely.

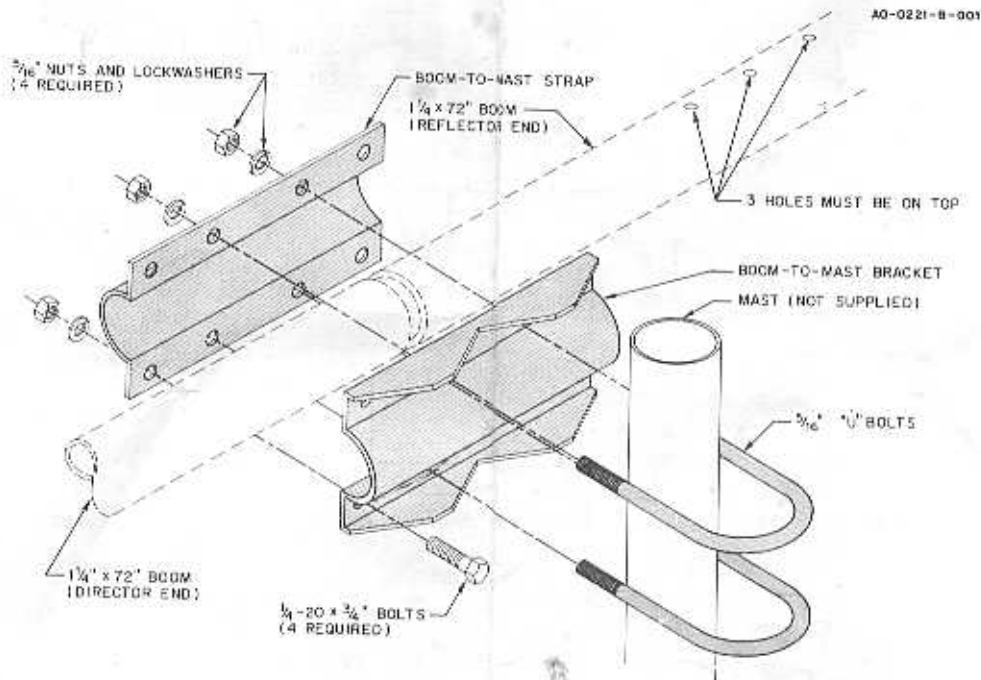

Figure 1. Boom-to-Mast Bracket Assembly

- () Place a 1 1/4" caplug on each end of the boom.
- () Place the two U-bolts into the boom-to-mast bracket and start the 5/16" nuts and lockwashers. *Do not tighten at this time.*

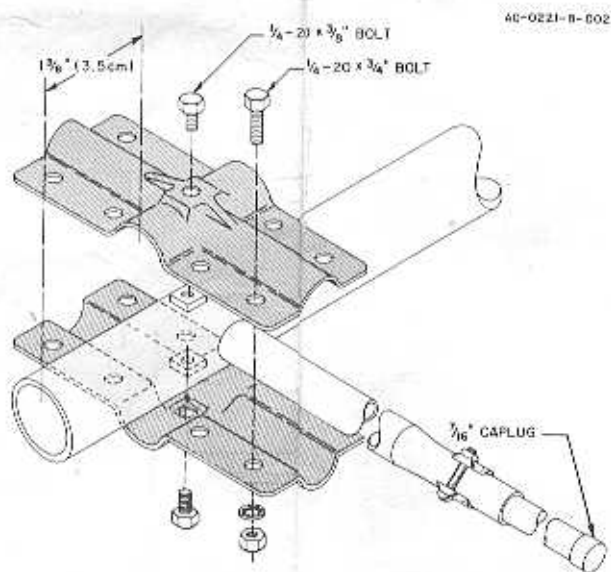

Figure 2. Reflector/Director Detail

- () Start at the reflector end (boom section that has the hole drilled in it) and measure 1 3/8" from the end of the boom and install the element-to-boom bracket as shown in Figure 2. Be sure to start the anchor screws and square nuts in the center hole. **Do not** tighten this screw.
- () Select the R1 sections (1/4" x 72") of tubing and slip one end of each in each side of the bracket and tighten the bracket securely with the exception of the two anchor screws—*Do not tighten at this time.*

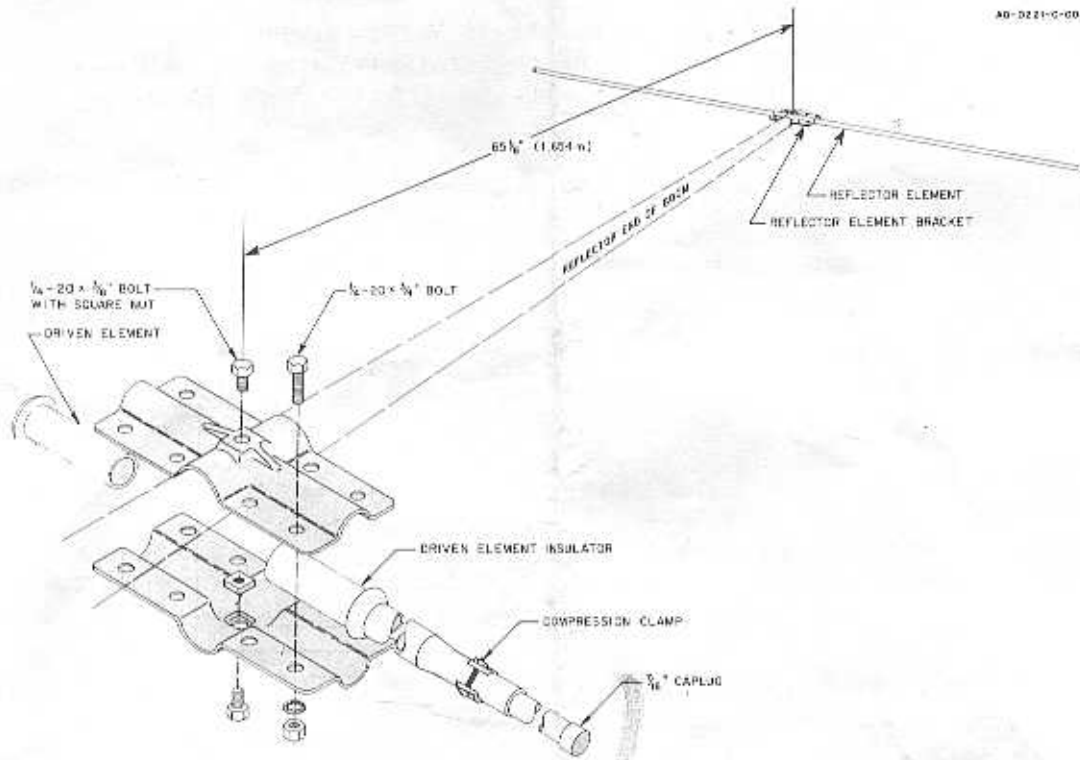

Figure 3. Driven Element Bracket Assembly

() Measure along the boom $65\frac{1}{8}$ " from the center of the reflector element-to-boom bracket and install the driven element-to-boom bracket. Select the DE sections and slip the driven element insulators onto one end of the DE1 sections ($\frac{3}{8}$ " x 72"). Slip the insulated end of the DE1 section into the driven element bracket and tighten securely. See Figure 3 for proper installation. *Do not tighten the anchor screws at this time.*

() Measure 74" from the center of the driven element bracket to the center of the director and install the director element-to-boom bracket. Select and install the D1 sections ($\frac{3}{8}$ " x 72") by slipping one into each side of the bracket and tighten securely. *Do not tighten the anchor screws at this time.*

() Now recheck the measurement and make certain all the elements are aligned evenly. Tighten the anchor screws on each element-to-boom bracket, securely.

AO-0221-A-004

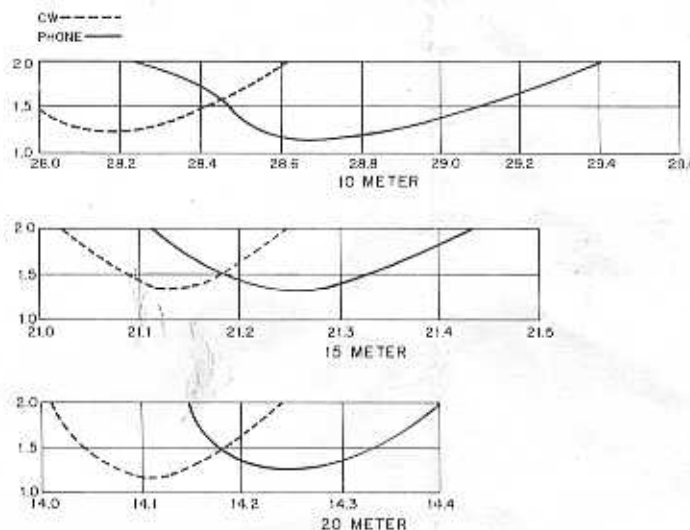

Figure 4. VSWR Chart

VSWR Charts

These VSWR curves are typical for this antenna mounted 70' above ground, horizontally polarized. Similar curves can be expected for this antenna mounted at least 30 feet above ground. **DO NOT** try to tune this antenna for low VSWR at ground level.

AO-0221-C-005

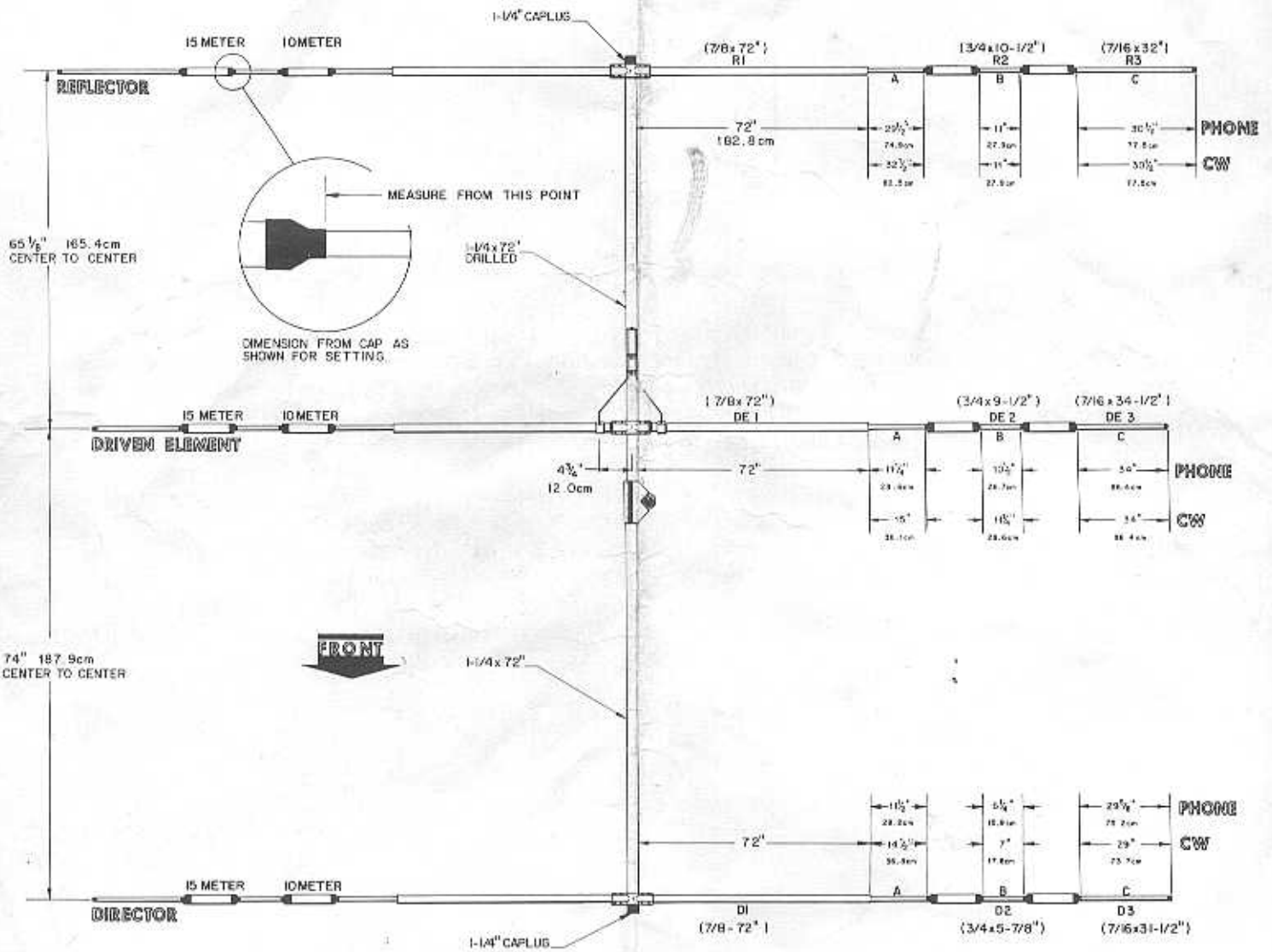

Figure 5. Element Layout and Dimensions

NOTE: At this time select your mode of transmission—either Phone or Continuous Wave (CW). Refer to the dimensions for your mode of transmission. Use the same mode for all dimensions.

() Select the 10-meter reflector trap (marked REF) and a $\frac{3}{4}$ " compression clamp using its associated $\frac{1}{4}$ " square nut and $\frac{1}{4}$ " x $1\frac{1}{4}$ " screw and slip it on the end of R1. Slip the longest end of the 10-meter trap into the R1 section to the dimensions given for your mode of transmission. Tighten the compression clamp slightly. See Figure 5.

() Select R2 ($\frac{3}{4}$ " x $10\frac{1}{2}$ ") and slip it onto the 10-meter trap assembly. Slip one compression clamp on each end of the R2. Tighten *slightly*.

Compression Clamps

Take care when measuring the tubing lengths for your mode of transmission. Place the clamp near the end of the tube with the joint even with the slot in the tube. Tighten the clamp until the inner tube cannot be turned in the outer tube.

Do not over tighten the compression clamps.

NOTE: To save time, loosely assemble all of the compression clamps and their appropriate hardware before beginning.

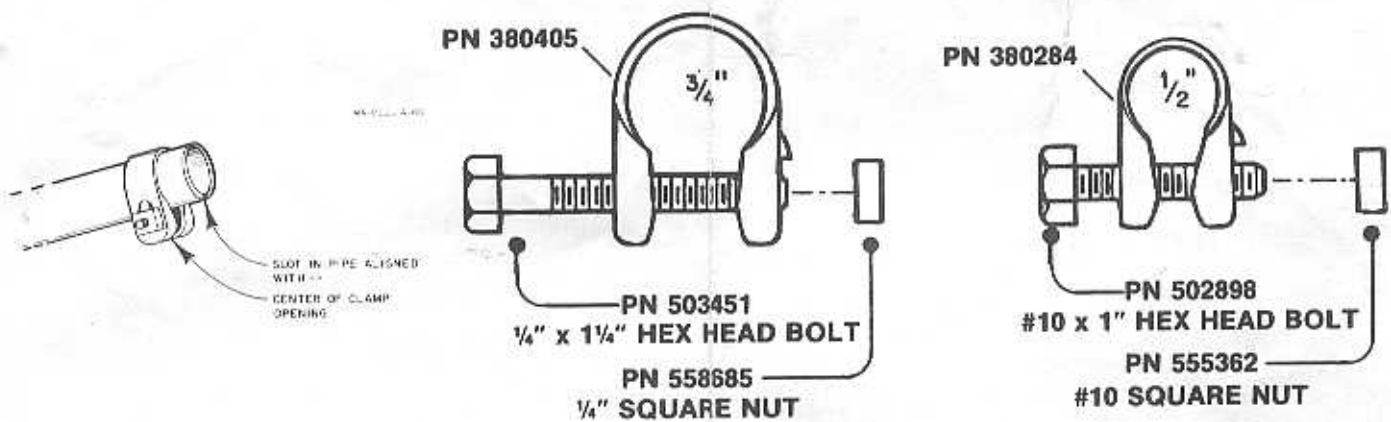

Figure 6
Compression Clamps

() Select the 15-meter trap assembly (marked 15 DIR/REF) and slip the unswaged end into the R2 section. Keep the R2 section approximately equidistant from the two traps and measure the dimensions shown in Figure 5 for your mode of transmission. Tighten compression clamps *slightly*.

() Select the R3 sections ($7/16$ " x 32 ") and slip it into the 15-meter trap assembly to the dimensions shown for your mode of transmission. Slip on the $\frac{1}{2}$ " compression clamp, #10 x 1" screw, #10 square nut, and tighten *slightly*.

() Place a $7/16$ " caplug on each end of the element.

NOTE: The remaining elements will be installed in the same manner as above with the exception of using the trap designated for that particular element. The traps are marked as follows:

10-Meter Traps
Director—10 DIR
Driven Element—10 DE
Reflector—10 REF

15-Meter Traps
Director—15 DIR/REF
Driven Element—15 DE
Reflector—15 DIR/REF

- () Select the remaining DE tube sections and install as before.
- () Select the remaining director tube sections and install as before.
- () Select the beta match support insulators. Install as shown in Figure 7.

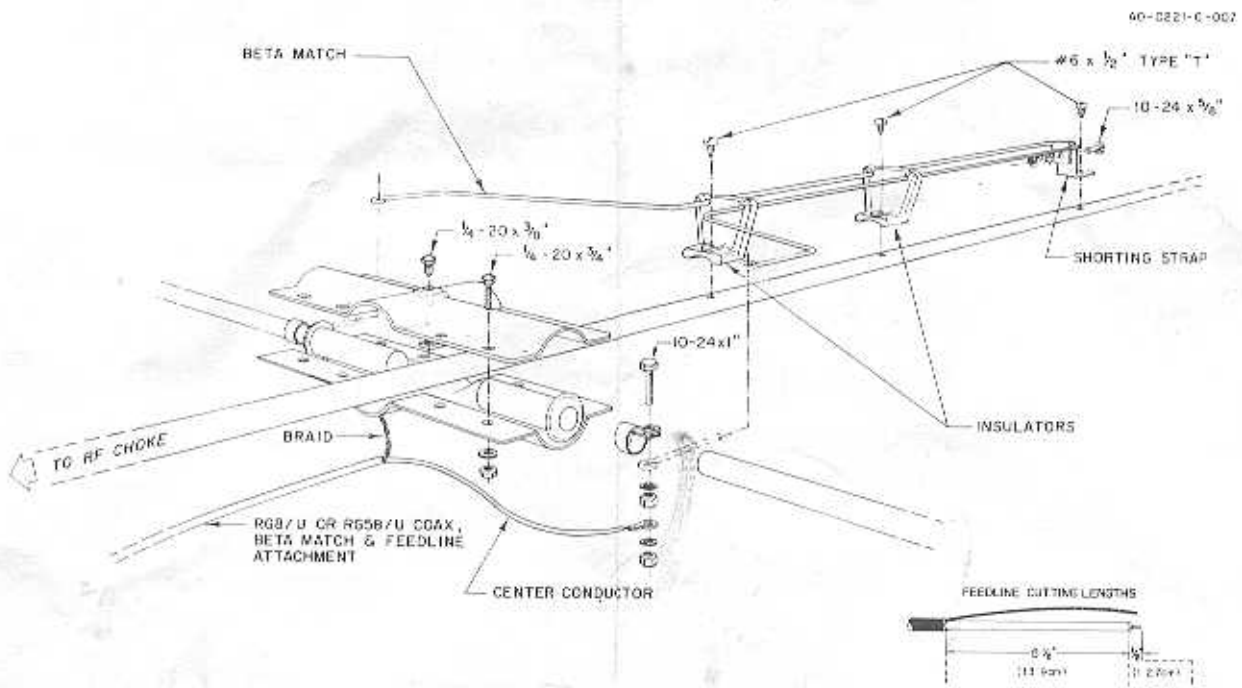

Figure 7. Beta Match/Feedline Attachment

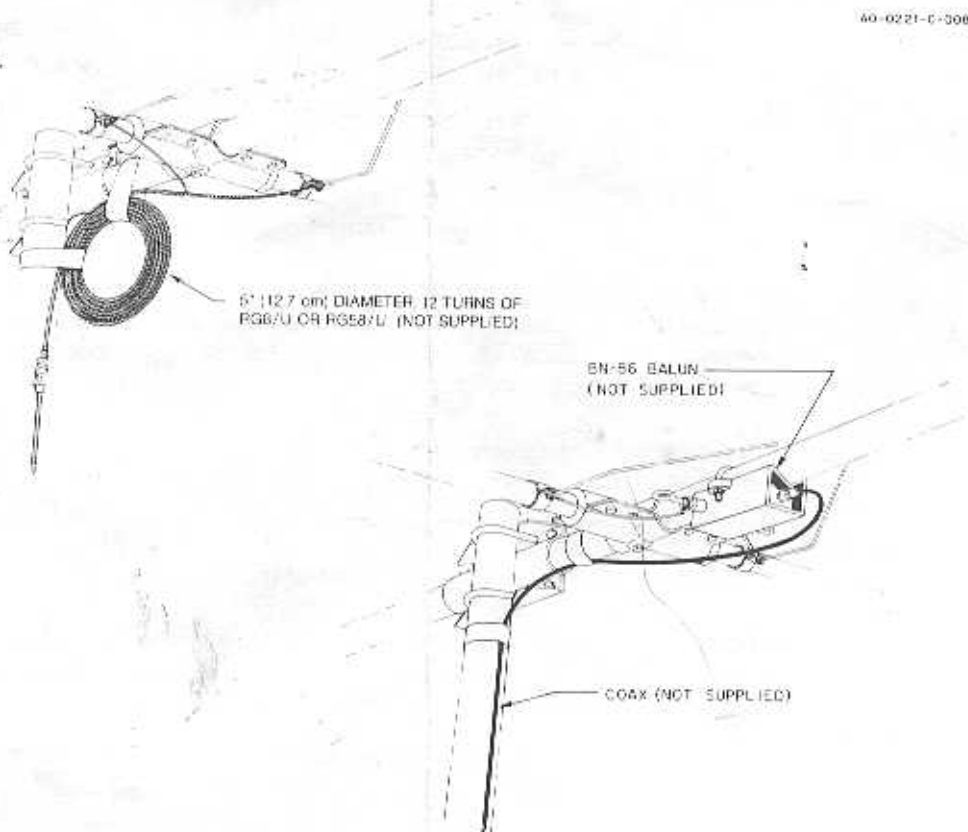

Figure 8. RF Choke

() Select the beta shorting strap and install as shown in Figure 7.

() Form an rf choke by winding twelve turns of coax in a coil approximately 5" in diameter. Tape securely to the TH3JR boom near the boom-to-mast bracket. Trim the end of the coax as shown in Figure 7. Attach the center conductor and the braid to the beta clamp as shown in Figure 8.

NOTE: For optimum performance of any beam antenna, a balun is highly recommended. The Hy-Gain BN-86 is available at your local Hy-Gain dealer.

() Carefully recheck all measurements, make certain the drain holes in the traps are facing down and then tighten all compression clamps securely.

() Make certain all electrical connections are tight. Weatherproof your coaxial connection using Neoprene, Pli-O-Bond or some similar substance.

NOTE: To prolong the life of this product in or around coastal areas, it is recommended that all hardware be encapsulated with a silicone rubber compound such as DOW-CORNING silastic rubber or G.E. silicone seal to prevent atmospheric deterioration.

() Slip the boom-to-mast clamp over your mast and tighten securely.

"Warning: Installation of this product near power lines is dangerous. For your safety, follow the installation directions."

() This completes your installation.

Parts List

Part No.	Description	Qty	Part No.	Description	Qty
190500	DE2, 3/8" x 9 1/2"	2	463767	insulator (driven element)	2
176211	boom (reflector) 1 1/4" x 72" drilled	1	455630	caplugs, 1 1/4"	2
174992	boom (director) 1 1/4" x 72"	1	455644	caplugs, 7/16"	6
190202	tube, 3/8" x 72", swaged	6	555362	nut, #10 square	7
871732	10-meter trap assembly (director)	2	567125	lockwasher, #10, internal	31
871733	10-meter trap assembly (reflector)	2	380294	compression clamp, 3/8"	6
871819	10-meter trap assembly (driven element)	2	506325	screw, 3/8" x 3/8", hex head	28
871734	15-meter trap assembly (dir. & refl.)	4	556960	nut, 3/8" hex	28
871820	15-meter trap assembly (driven ele.)	2	567110	lockwasher, 3/8", internal	30
190501	R2, 3/8" x 10 1/2"	2	545146	U-bolts, 5/16"	2
176212	DE3, 7/16" x 34 1/2"	2	556945	nut, 5/16", hex jam	4
176214	D3, 7/16" x 31 1/2"	2	567075	lockwasher, 5/16", internal	4
176216	R3, 7/16" x 32"	2	463642	beta match insulators	2
190502	D2, 3/8" x 5 3/8"	2	523616	screw, #6 x 3/8" Type T, round head	3
165138	element-to-boom bracket (DE)	2	169339	tubing clamp, 3/8"	2
165141	element-to-boom bracket (D & R)	4	502898	screw, #10 x 1", hex head	8
385142	boom-to-mast bracket	1	558685	nut, 3/8" square	24
385144	boom-to-mast strap	1	556970	nut, #10 hex	5
176232	beta match	1	505540	screw, 3/8" x 3/8", hex head	6
871514	Parts Pack A, 221	1	380405	compression clamp, 3/8"	18
506480	screw, #10 x 3/8", round head	1	503451	screw, 3/8" x 1 1/2", hex head	18
173370	beta shorting clamp	1			

The following scale and conversion factors are listed for your convenience in determining the relationship between dimensions given in feet and inches and the metric system:

UNIT	ABBREVIATION	LENGTH	METRIC EQUIVALENT
INCH	.IN or "	0.083 FEET	2.540 CENTIMETERS
FOOT	FT or '	12 INCHES	30.480 CENTIMETERS

