

Hy-gain

INSTRUCTION MANUAL

ORDER NO. 389

TH6-DXX

"SUPER THUNDERBIRD"

PN 801129

General Description

The Hy-Gain TH6-DXX "Super Thunderbird" is a 6-element beam designed to operate on 10, 25 and 20 meters. It has four active elements on 10-meters and three active elements on 15 and 20 meters. The "Super Thunderbird" has optimum spaced elements on a 24 foot boom giving you the best gain while maintaining a high front-to-

There are two methods for raising this antenna. Decide which method you will use before you begin; it will determine how you put the antenna together.

Method 1. Completely assemble the antenna on the ground then hoist it into position using a setup as shown in Figure 1.

Method 2: Assemble the antenna on the ground in halves, then hoist each half up the tower and assemble in the boom-to-mast bracket on the tower- as shown in Figure 2.

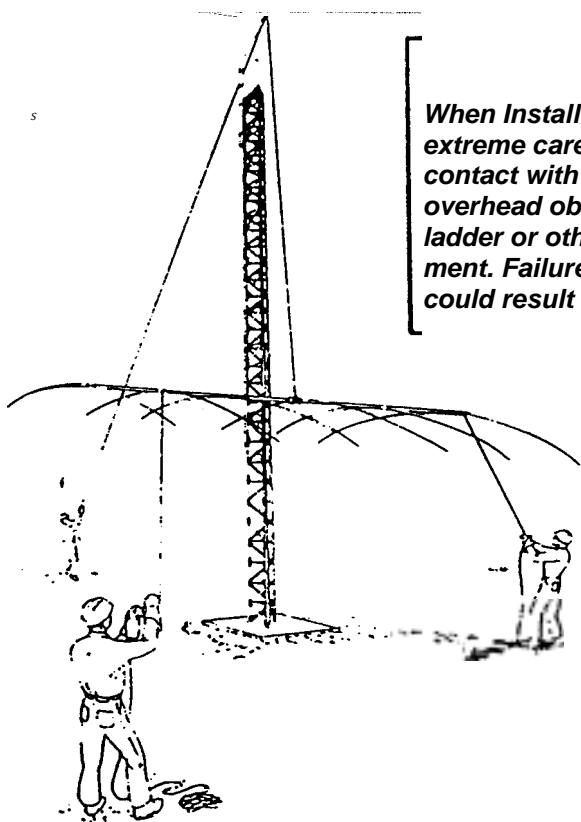

Complete Antenna Hoisted
On **Tower** By **Cable** or
Rope

Figure 1

WARNIN
When Installing your system, take extreme care to avoid accidental contact with power lines and other overhead obstructions by any ladder or other installation equipment. Failure to exercise this care could result in serious injury.

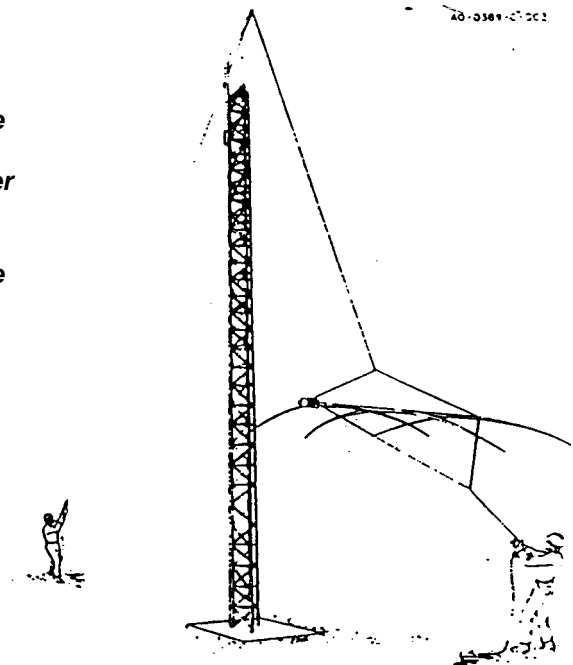

Antenna Section
Being Erected On
Tower

Figure

All slotted tubing supplied with the TH6-DXX telescopes together. It is held in place with compression clamps. Make all measurements as accurate as possible using the given dimensions for optimum results from your antenna.

Compression Clamps

Take care when measuring the tubing lengths for your mode of transmission. Place the clamp near the end of the tube with the joint even with the slot in the tube. Tighten the clamp until the inner tube cannot be turned in the outer tube. The compression clamps and their associated hardware are shown in Figure 7. Do not tighten the compression clamps until instructed to do so.

NOTE: To save time, loosely assemble all of the compression clamps and their appropriate hardware before beginning further installation of the antenna.

Assembly Of The Boom

Select the two halves of the boom brackets (items 7 & 8) and the two cast aluminum mast clamps (item 1) and loosely assemble as shown in Figure 4.

Select the four boom sections (items 6, 12 & 13) 2" diameter tubing. Slip the unswaged end of the long boom section (items 12 & 13) into the boom-to-mast bracket (items 7 & 8) and line up the holes. Secure the boom sections to the bracket using the two 5/16"-18 x 2 3/4" bolts (item 63), nuts (item 69) and lockwashers (item 74) provided. Do not tighten at this time. The bracket must be loose to facilitate mounting the antenna on

NOTE: The reflector end of the boom (item 12) has a small hole drilled 7 1/8" from the unswaged end. This hole must be positioned so it is facing up (skyward) when the boom is assembled. The hole will be used for attaching the beta match in a later step. Refer to Figure 4.

Slip the remaining boom section (item 6) over the swaged end of the assembled boom section (items 12 & 13) and secure using the 1/4"-20 x 2 1/2" bolt (item 65), nut (item 70) and lockwasher (item 77) as shown in Figure 4.

NOTE: The boom-to-mast brackets have a hole through their center to allow securing to the mast with the 5/16"-18 x 3 1/2" bolt. It is recommended that the mast be removed and a 1 1/32" hole be drilled at the desired mast clamp position, then reinstall the mast. If this is not possible, the clamp will hold its position on the mast in all but

VSWR Charts

These VSWR curves are typical for this antenna mounted 70 feet above the ground, horizontally polarized. Similar curves can be expected for this antenna mounted between 50 and 100 feet above the ground. **Do not try to tune this antenna for low VSWR at ground level!**

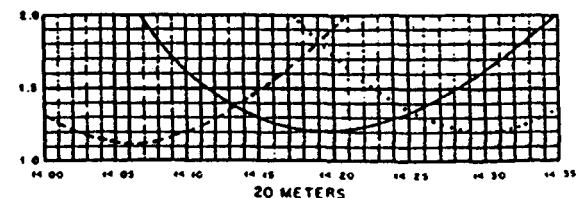
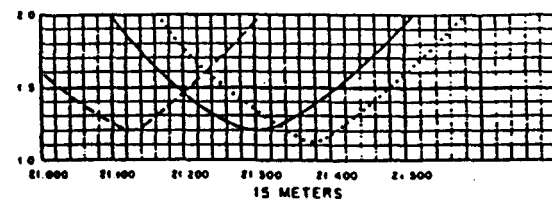
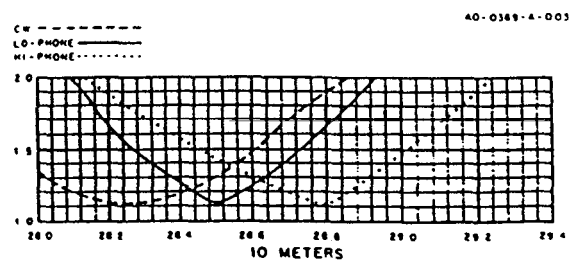

Flaure 3

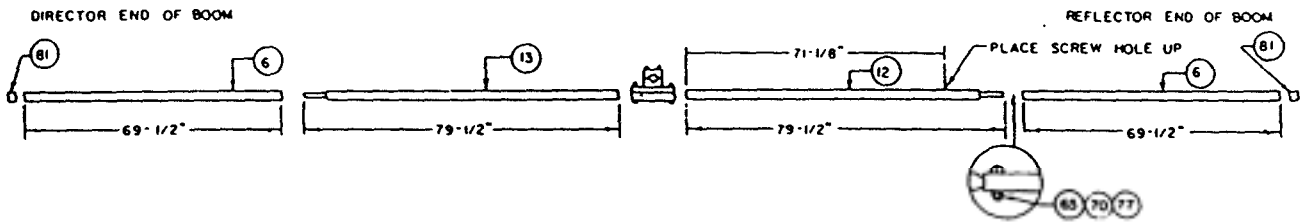
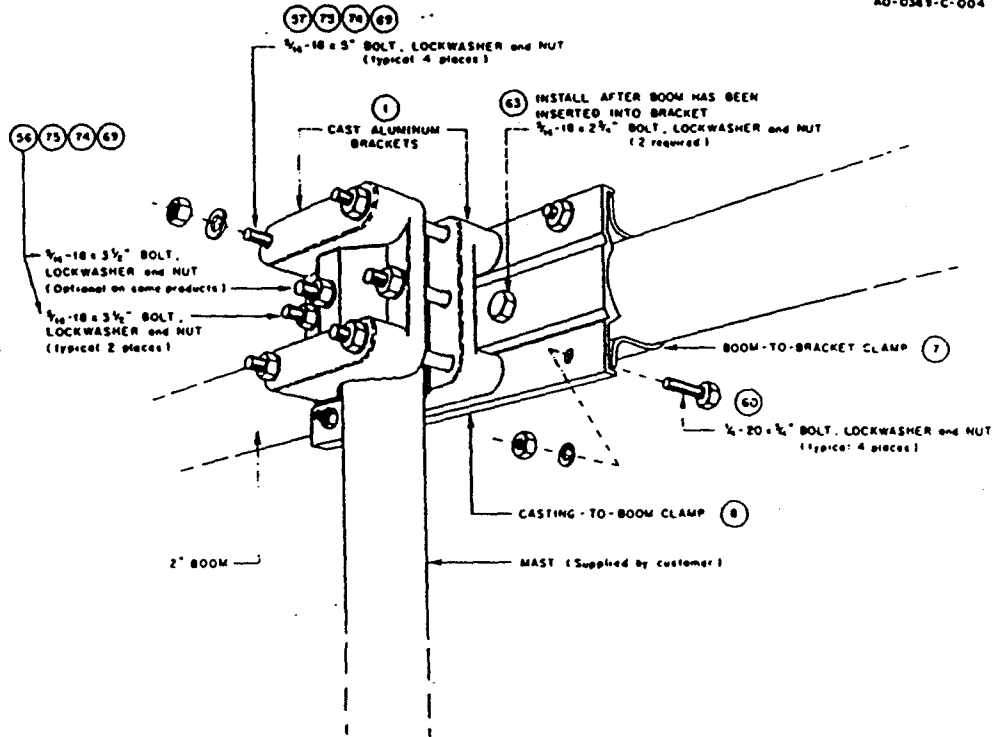

AO-0226-C-004

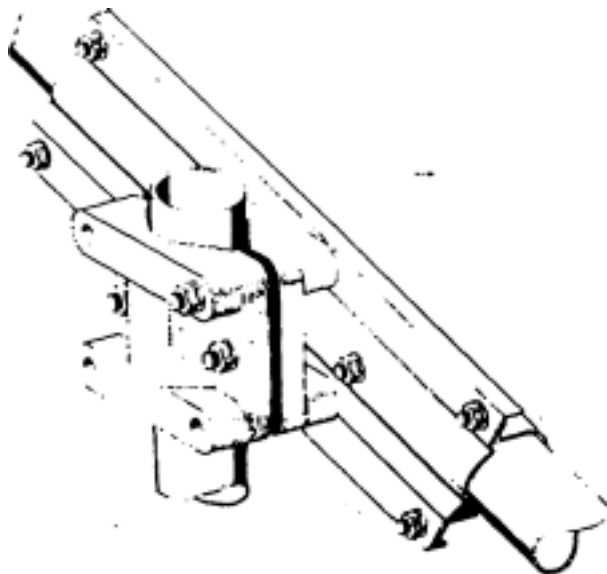

Item	Description
1	bracket, cast aluminum
6	boom section, 2 x 69 1/2"
7	clamp, boom-to-bracket
8	bracket, casting-to-boom
12	boom tube assembly, beta
13	boom tube assembly
56	screw, 5/16-18 x 3 1/2" hex head
57	screw, 5/16-18 x 5" hex head
60	screw, 1/4-20 x 3/4" hex head
63	screw, 5/16-18 x 2 3/4" hex head
69	nut, 5/16-18 hex jam
74	lockwasher, 5/16" split
75	washer, 5/16" flat
81	2" caplug
65	screw 1/4-20 x 3/4" round head
70	nut 1/4-20 hex
77	lockwasher 1/4" internal

Figure

Pre-assembling The Select a large sized set of element-to-boom brackets.(item 4) marked with a number 14.

Element-to-Boom Brackets On The

Pre-assemble the brackets on the reflector end of the boom about 18 1/2" from the center of the boom-to-mast clamps. The reflector end of the boom can be identified by the

Select a small sized element-to-boom bracket (item 2) marked with a number 4 and loosely assemble, on the reflector end of the boom 75" from the driven element brackets that you assembled earlier. Refer to Figure 5B. These brackets *will* be the 10-meter reflector brackets. *DO NOT TIGHTEN.*

Select a set of medium sized element-to-boom brackets (item 3 marked *with* a number 13 and loosely assemble on the reflector end of the boom as shown in Figure 5B. Assemble the bracket 3 inches from the end of the boom to the center of the bracket. This pair of brackets will be for the 15 - 20-meter reflector.

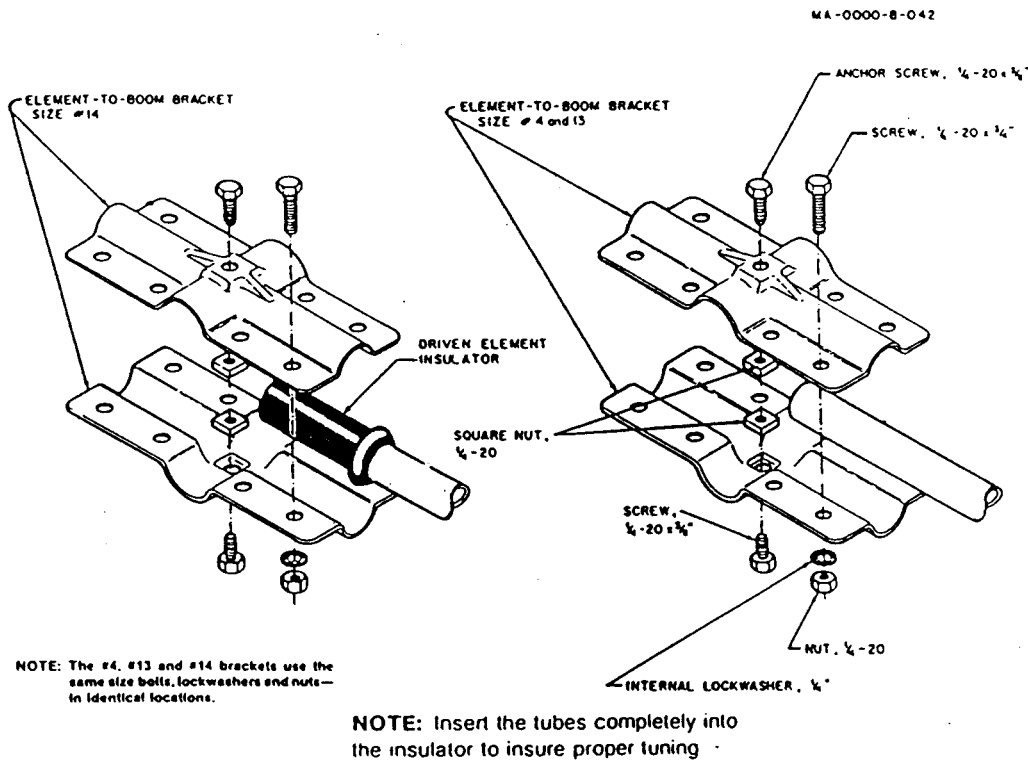

Figure 5

Assembly of boom 15-20-Meter Reflector

NOTE: The following steps will be in singular form. Do them first for one side of the then for the other side.

Select the "15-20 Ref" tubing bundle (item 36). Insert the thick-walled end of the R1 (t 1/4" x 95 1/2") into the element-to-boom bracket (item 3) assembled on the boom. Tighten the screws to hold the element securely but do not tighten the anchor screws

Check to see that the 15 - 20-meter reflector element will lie in a plane parallel to the earth when the antenna is mounted on the mast. This can be done by observing the position of the reflector element with respect to the boom-to-mast bracket and then adjusting the reflector element accordingly. Recheck the 3" measurement from the end of the boom to the center of the bracket then tighten the anchor screws

Select a 1/4" compression clamp (item 48) and its associated screw (item 80) and nut (item 68) and assemble as shown in Figure 7.

NOTE: Figure 7 shows all the compression clamps with their associated hardware. The drawing is full size to aid you in identifying the parts. Lay the part over the proper drawing for easy identification.

Slip the assembled compression clamp over the end of the R1 section (item 39). Select the R2 section (1 1/8" x 38") and slip the unswaged end into the R1 section.

At this time, you must decide which mode of transmission you will use either Lo Phone, Hi Phone or CW. Measure the dimension of R2 for your mode of transmission as shown in Figure 6. The measurement is made from the end of R1 to the end of R2.

CAUTION

When you have *selected* your mode of transmission (Lo Phone, Hi Phone or CW), you must use *the* same mode for remaining measurements. Do not attempt to use averages or various combinations of setting measurements on *the* same element, or *serious deterioration in antenna performance will result. the VSWR charts shown in Figure 3 should help you to decide which mode to select.*

Assemble a 1" compression clamp (item 49) as shown in Figure 7. Slip the assembled clamp over the end of R2. Select the 15-meter parasite trap and slip the unswaged end into the R2 section with drain hole down.

CAUTION

- There are two style 15- and 10-meter traps. Observe *the* part number marking closely, as shown in Figure 6. *The Driven Element traps are different internally than the parasitic element traps.*

Measure 1" from the end of the R2 section to the edge of the plastic trap cap as shown in Figure 6. Now, tighten the compression clamp *SLIGHTLY*.

Assemble a 1/2" compression clamp (item 45) as shown in Figure 7. Slip the assembled clamp over the end of the 15-meter trap. Select the R3 section (item 37, 7/16" x 37") and slip it into the 15-meter trap. Measure dimension of R3 for your mode of transmission as shown in Figure 6. Tighten compression clamp *SECURELY*.

Carefully recheck all your measurements then tighten the compression clamps *SECURELY*.

Assembly of 10-Meter Reflector

Select the "10 Ref" tubing bundle (item 32) and slip the unswaged end of the R2-1 section (item 35, 3/4" x 55") into the bracket (item 2) assembled on the boom. Tighten the screws to hold the element securely but do not tighten the anchor screws at this

Check to see that the 10-meter reflector will lie in the same plane as the 15-20 meter reflector and carefully recheck the 48" measurement from the center of the one reflector bracket to the center of the other reflector bracket. Now tighten the anchor screws *SECURELY*.

Assemble the remainder of the 10-meter reflector in the same manner as you did the 15-20 meter reflector. Refer to Figures 5, 6 and 7 for illustrations.

Assembly of the Driven Element

() Select the DE1 section (31) (1 1/4" x 48") from the Driven Element tubing bundle (26). Slip a Driven Element insulator (85) on the unslotted end of the DE1 section. Then slip the insulated end of DE 1 into the bracket assembled on the boom. Tighten the screws to hold the element securely but do not tighten the anchor screws at this time.

() Check to see that the Driven Element will lie in the same plane as the Reflector elements already installed. Carefully re-check the 75" measurement from the center of the 10-meter Reflector bracket to the center of the Driven Element bracket then tighten the anchor screws *SECURELY*.

() Assemble a 1 1/4" compression clamp (48) as shown in Figure 7. Slip the assembled clamp over the DE1 section. Select the DE2 section (29) (1 1/4" x 42") and slip the unswaged end into the DE1 section. Measure the DE2 dimension for your mode of transmission as shown in Figure 6 then tighten the compression clamp.

() Assemble a 1" compression clamp (49) as shown in Figure 7. Slip the assembled clamp over the end of the DE2.

() Select the 10-meter Driven Element trap (44). If you look closely at the trap, you will notice that the part number is marked near one end. This is the *SHORTED* end of the trap. Slip the *SHORTED* end of the trap into the DE2 section (29) and measure 1" from the end of DE2 to the plastic trap cap as shown in Figure 6. Now tighten the compression clamp *SLIGHTLY*.

() Assemble two 1" compression clamps (49) and slip them on each end of the DE3 section (30) (1 x 5") positioning them near each end. Slip the DE3 section over the 10-meter trap (44) then slip the unswaged end of the 15-meter Driven Element trap (42) into the DE3 sections. Keeping the DE3 section approximately equidistant from the two traps, measure the DE3 dimension for your mode of transmission as shown in Figure 6. Now tighten the compression clamps *SLIGHTLY*.

() Assemble a 1/2" compression clamp (45) as shown in Figure 7 and slip it over the swaged end of the 15-meter trap. Select the DE4 section (27) (7/16 x 28") and slip it into the 15-meter trap. Measure DE4 dimension for your mode of transmission as shown in Figure 6. then tighten compression clamp *SLIGHTLY*.

() Carefully re-check all dimensions then tighten the compression clamps *SECURELY*.

Assembly Of Beta Match

() Select the Beta Match tubes (28) (36 x 38 3/4"). Beta shorting wire (5) (1/8" formed wire) and the beta supporting insulator (83) and clamps (84) as shown in Figure 8. Attach the shorting wire to the beta tubes using the two 10-24 x 1/2" screws (61) square nuts (68) and lockwashers (78). Assemble the beta tubes on the boom as shown in Figure 8. using four 10-24 x 2" screws (79), nuts (68) and lockwashers (78) but do not tighten the screws at this time.

() Select the beta shorting clip and secure to the end of the beta shorting wire using a 10-24 x 1/2" screw (61) nut (65) and lockwasher (78). Attach the shorting clip to the boom using a No. 10 sheet metal screw and lockwasher (66) & (78). Now tighten all screws *SECURELY*.

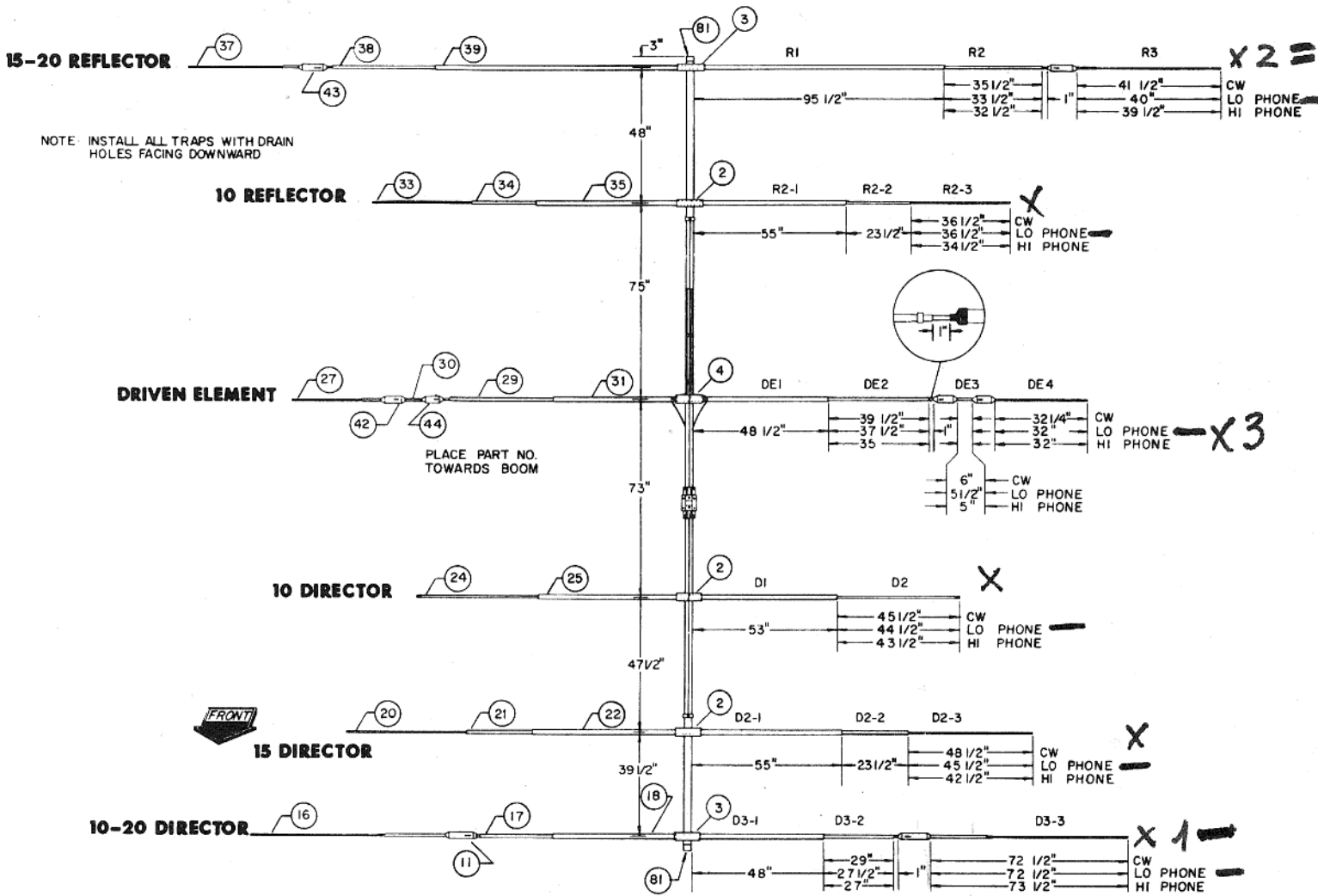

Item #	Description
11	trap, 10 m Director
16	D3-3, 7/16" x 52"
17	D3-2, 1 1/8" x 32 1/2" swaged 1/8"
18	D3-1, 1 1/8" x 48"
20	D2-3, 7/16" x 52"
21	D2-2, 5/8" x 26"
22	D2-1, 1/8" x 55"
24	D2, 7/16" x 48"
25	D1, 7/8" x 53" swaged 7/16"
27	DE-4, 7/16" x 28"
29	DE-2, 1 1/8" x 42" swaged 1/8"
30	DE-3, 1" x 5"

Item #	Description
31	DE-1, 1 1/4" x 48"
33	R2-3, 7/16" x 39"
34	R2-2, 5/8" x 26", swaged 7/16"
35	R2-1, 1/8" x 55" swaged 1/8"
37	R-3, 7/16" x 37"
38	R-2, 1 1/8" x 38" swaged 1/8"
39	R-1, 1 1/4" x 95 1/2"
42	trap, 15 m, Driven Element
43	trap, 15 m
44	trap, 10 m, Driven Element
81	caplug, 2"

Figure 6

Assembly Of The 10 Meter Director

() Select a set of small element-to-boom brackets (2), marked with a number 4, and LOOSELY assemble them on the boom 73" from the center of the driven element bracket to the center of the 10 meter director bracket as shown in Figure 5 and 6.

() Select the "No. 10 Dir" tubing bundle (23) and assemble it on the boom in the same manner as you did the previous elements. Refer to Figures 5, 6 and 7. Make certain the 10 meter Director lies in the same plane as the other elements and carefully re-check the 73" dimension before tightening the bracket anchor screws SECURELY.

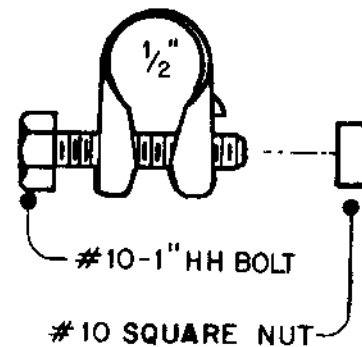
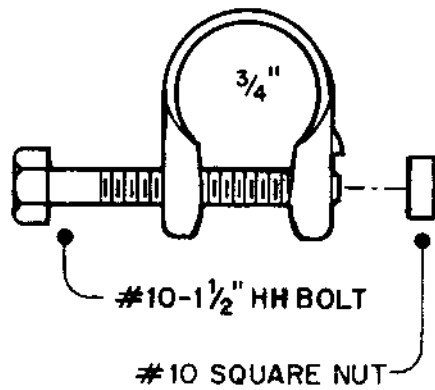
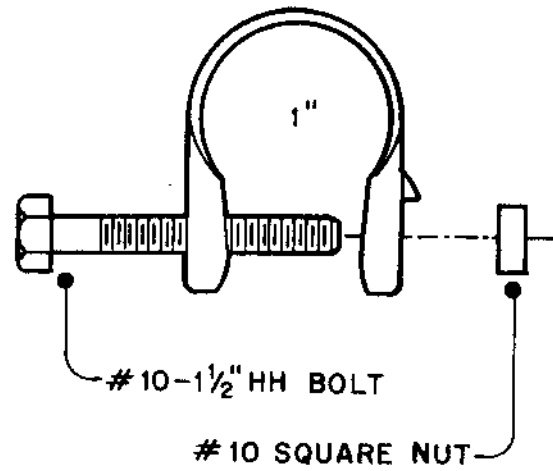
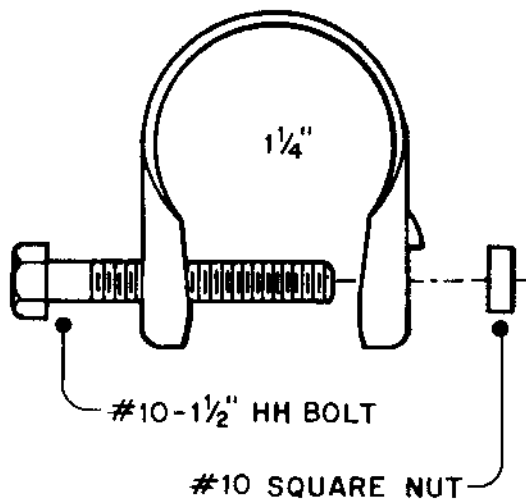

MA-CC31-A 002

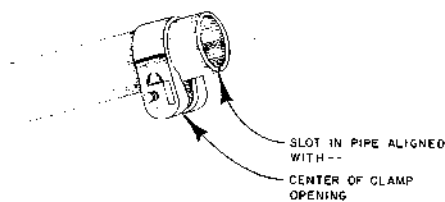

Item #	Description
45	compression clamp, 1/2"
46	compression clamp, 3/4"
48	compression clamp, 1 1/4"
49	compression clamp, 1"
58	10-24 x 1", hex head
68	nut, 10-24 square
80	10-24 x 1 1/2", hex head

Figure 7

15 Meter Director Assembly

() Select the remaining set of small element-to-boom brackets (2), marked with a number 4, and *LOOSELY* assemble on the boom 47 1/2" from the center of the 10 meter Director bracket to the center of the 15 meter Director bracket.

() Select the "15 Dir" tubing bundle (19) and assemble on the boom in the same manner as the previous elements. Refer to Figures 5, 6, and 7 for illustrations. Make certain the 15 meter Director lies in the same plane as the other elements and carefully re-check the 47 1/2" dimension before tightening the bracket anchor screws *SECURELY*.

A X 10-20 Meter Director Assembly

() Select the remaining set of medium sized element-to-boom brackets (3), marked with a number 13, and *LOOSELY* assemble on the boom 39½" from the center of the 15 meter Director bracket to the center of the 10-20 meter Director bracket.

() Select the "10-20 Dir" tubing bundles (15) and the 10-meter Director trap (11) and assemble in the same manner as the previous elements. Refer to Figures 5, 6, and 7 for illustrations. Make certain the 10-20 meter Director lies in the same plane as the other elements and carefully re-check the 39½" dimension before tightening the bracket anchor screws *SECURELY*.

() Place a 7/16" caplug on the end of each element and a 2" caplug on each end of the boom.

Feedline and RF Choke Attachment

() Wind an RF choke similar to the one in Figure 8. The choke must consist of 12 turns of RG-8/U coaxial cable with each turn having 6" diameter. Allow enough cable at the end to reach from the mast to the driven element. Strip the coaxial cable as shown in Figure 8, Detail 2 and attach a solder lug (not supplied) to the center conductor and a solder lug to the braid.

NOTE: This RF choke is necessary for the antenna to operate properly. Hy-Gain Balun Model BN-86 allows the TH6-DXX to operate with greater efficiency than with the "homemade" choke. The model BN-86 is available at your local Hy-Gain dealer.

() Select the two 1¼" tubing clamps (87) and install one on each side of the driven element placing them close to the insulator (85) as shown in Figure 6 and 8.

() Attach the center, conductor from the RF choke and a pigtail lead (wire with solder lug at each end) to one tubing clamp and the RF choke braid and the other pigtail lead to opposite tubing clamp as shown in Figure 8. Connect the loose end of each pigtail lead to the beta tube using a ½" screw, square nut and lockwasher. Weatherproof the coax connection using Pli-O-Bond, Neoprene or some similar substance. Also weatherproof the coaxial cable where the braid leaves the outer insulator to prevent water from entering the coax and ruining the first few feet of cable. Tape the braid with waterproof tape to prevent it from shorting out on the antenna.

() Tape the RF choke and feedline securely to the boom using water-proof tape. Later, when the antenna is mounted to the mast, tape the choke securely to the mast.

Assembly Of The Boom Support Cable

() Select the 2" ID boom support clamps (55) and the boom support straps (90) and *LOOSELY* assemble on the boom approximately 100" from the boom-to-mast clamp as shown in Figure 9. Attach the boom support cable (9) to the clamps using the thimbles (53) and cable clips (54) provided. Refer to Figure 9. Attach the turnbuckles (51) to the opposite end of the cable as shown in the illustrations.

() Now tape the cables near the boom-to-mast bracket so they will be handy later when the antenna has been mounted on the mast. Make certain the cable is above the element.

() Mount the antenna on your mast using one of the methods suggested in the beginning of this section. Allow approximately 36" of the mast to extend above the boom-to-mast bracket for attaching the boom support cable.

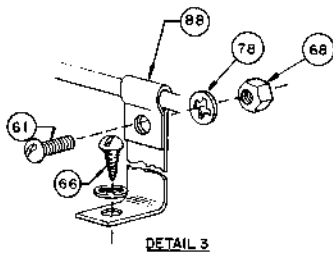
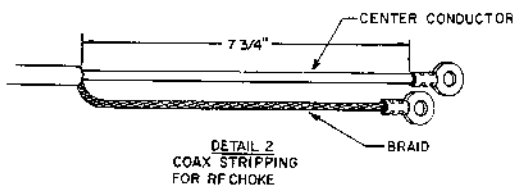
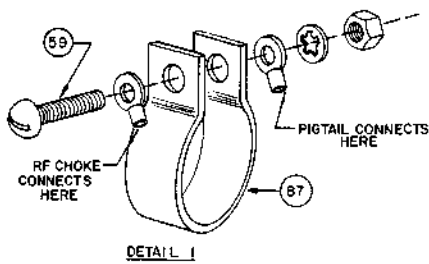
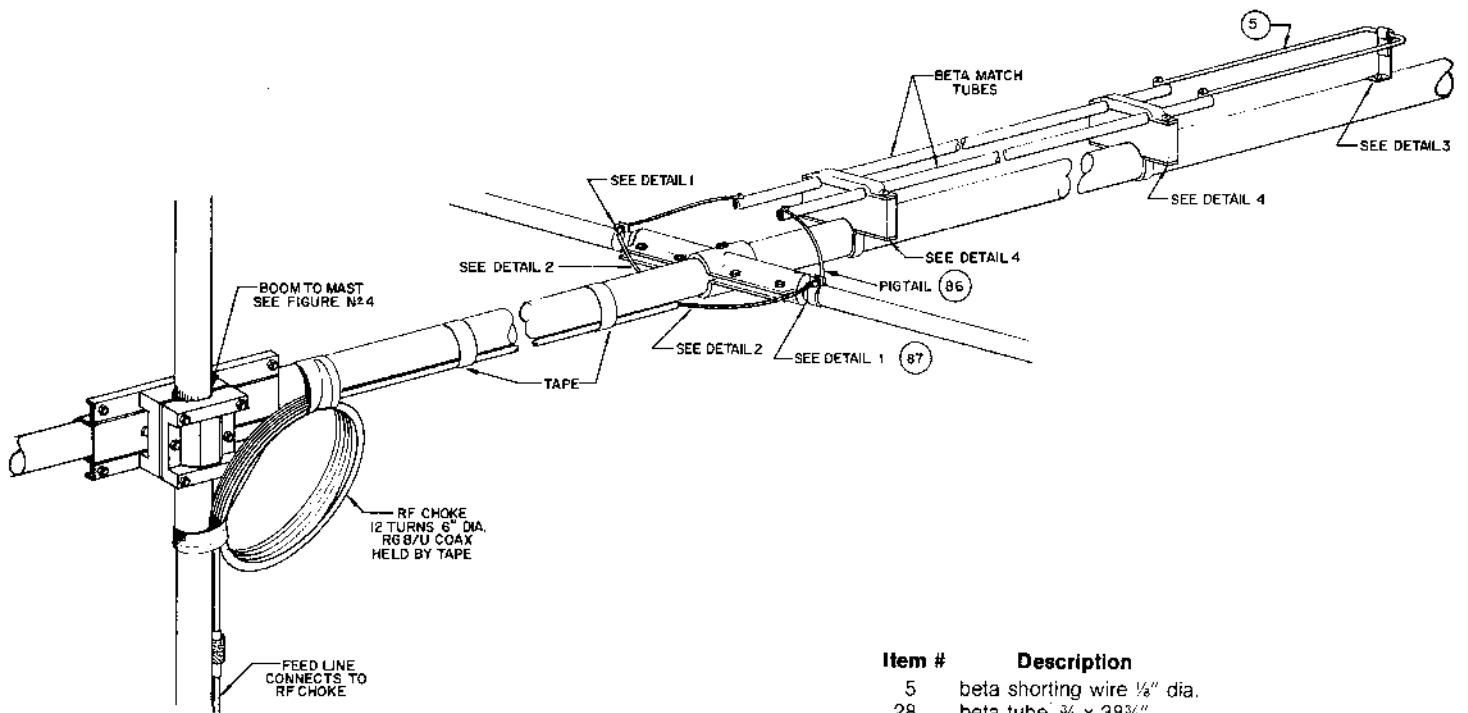

Item #	Description
5	beta shorting wire 1/8" dia.
28	beta tube, 3/4 x 38 3/4"
50	clamp beta support
59	screw 1/4-20 x 1 1/4" round head
61	screw, 10-24 x 1/2" round head
66	screw, 10 x 1/8 type A round head
68	nut, 10-24 square
78	lockwasher, #10 int.
79	screw, 10-24 x 2" round head
83	caplug, 7/16"
84	insulator beta support (top)
86	pigtail leads
87	clamp, 1 1/4" tubing
88	clip beta shorting

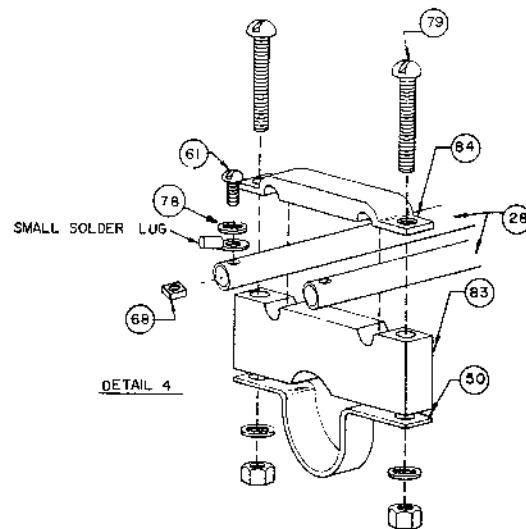
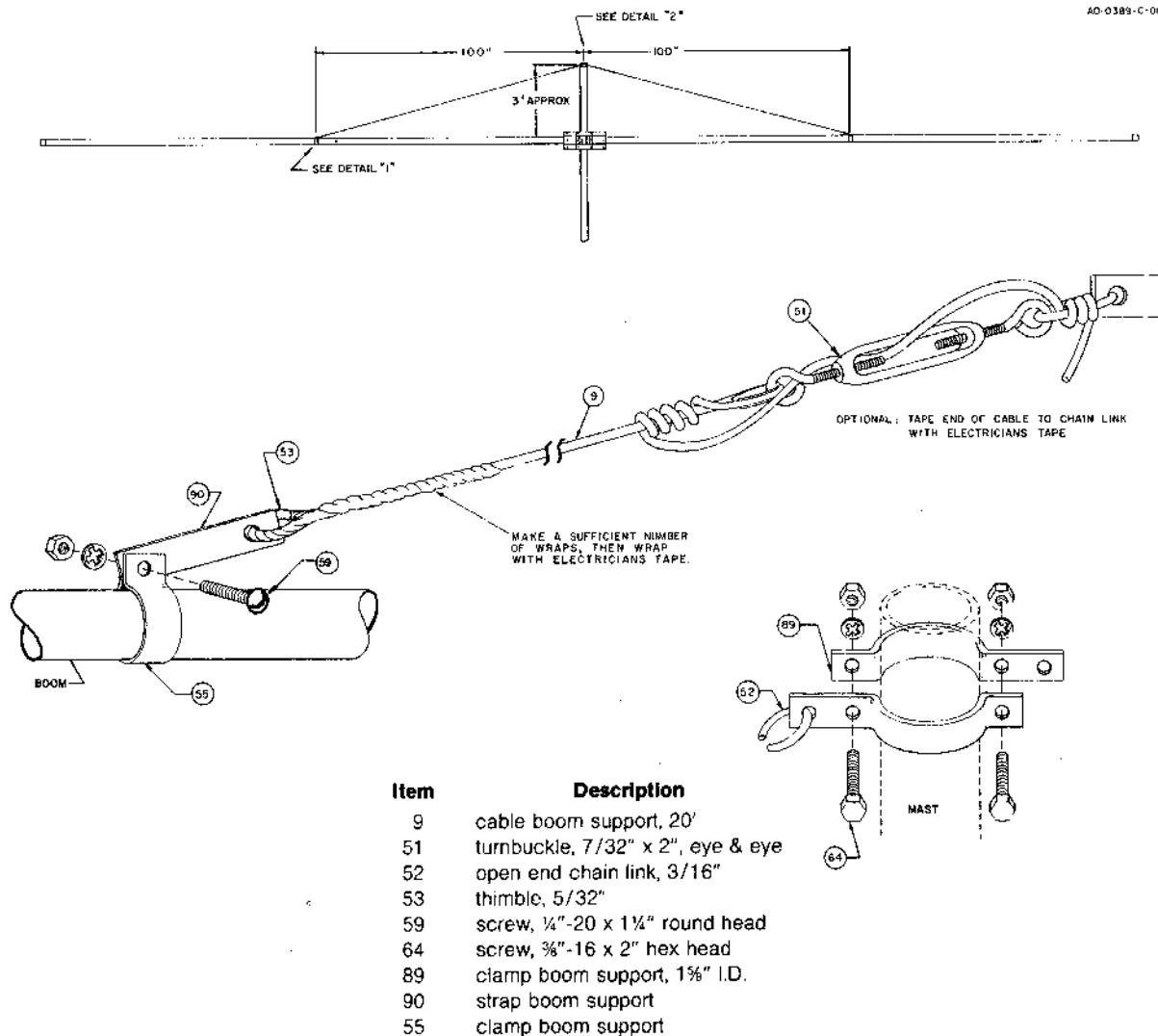

Figure 8

() Assemble the 1 1/2" boom support clamp (89) (2 piece) on the mast as shown in Figure 9. Extend the turnbuckles to its full length then attach to the chain link and tighten the clamp **SECURELY**. Tighten each turnbuckle until the boom lies in a level plane with no sag.

() Using excess wire from the boom support cable, wrap 10 turns of this wire on the support cable near each turnbuckle, then thread each wire through the eyebolts and turnbuckle centers and finally the chainlinks and tie off. This will prevent the turnbuckle from loosening during severe weather conditions.



Item	Description
9	cable boom support, 20'
51	turnbuckle, 7/32" x 2", eye & eye
52	open end chain link, 3/16"
53	thimble, 5/32"
59	screw, 1/4"-20 x 1 1/4" round head
64	screw, 3/8"-16 x 2" hex head
89	clamp boom support, 1 1/2" I.D.
90	strap boom support
55	clamp boom support

Figure 9

Lightning Protection

For lightning protection and noise-free operation you must ground your antenna supporting structure. A proper ground consists of a 1/2"-8' ground rod driven into the ground as close as possible to the base of your tower or mast. Connect the rod to the tower or mast using a copper strap or 12-gauge copper or aluminum wire.

For total protection of your equipment a Hy-Gain Model LA-1 Lightning Arrestor is available at your local Hy-Gain dealer.

THIS COMPLETES YOUR INSTALLATION OF THE TH6DX. ATTACH YOUR FEEDLINE TO THE RF CHOKE AND HAPPY DX'ING.

Specifications

Electrical

Input Impedance	52 ohms
Forward Gain	10 m - 9.5 dB
	15 m - 8.5 dB
	20 m - 8.0 dB
Front-to-Back Ratio.....	25 dB
Maximum Power Input	1 kw AM
VSWR (at Resonance)	1.2:1
Lightning Protection	DC Ground

Mechanical

Boom Length	24 ft. (7.31 m)
Boom Diameter	2 in. (5.08 cm)
Longest Element	31 ft. (9.44 m)
Accepts Mast	1 ¼" to 2 ½" O.D. (3.17 cm)
Maximum Wind	100 mph (160.93 kmph)
Wind Surface Area	8.09 sq. ft. (.75 sq. m)
Wind Load (80 mph).....	207.0 lbs. (93.89 k)
Turning Radius.....	20 ft. (6.09 m)

Converting English Measurements to Metric

Use this scale to identify lengths of bolts, diameters of tubes, etc. The English (") and foot (') can be converted to centimeters in this way.

1 inch (1") = 2.54 cm

1 foot (1') = 30.48 cm

Example:

42" x 2.54 = 106.7 cm

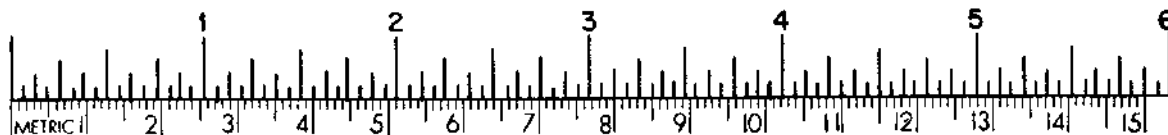

Parts List

Item	Part No.	Description	Qty	Item	Part No.	Description	Qty
1	102734	bracket, cast aluminum	2	50	177888	clamp, beta support	2
2	163764	bracket, element-to-boom #4	6	51	351243	lurnbuckle, 7/32" x 2", eye and eye	2
3	165919	bracket, element-to-boom #13	4	52	351244	open end chain link, 3/16"	2
4	165920	bracket, element-to-boom #14	2	53	351700	5/32 wire rope thimble	4
5	171151	beta shorting wire, 1/8" x 24 3/4"	1	54		(Not assigned)	
6	171166	boom section, 2" x 69 1/2"	2	55	338861	clamp, boom support	2
7	172732	clamp, boom-to-bracket	1				
8	172735	bracket, casting-to-boom	1	40	879903	Parts Pack B contains the following:	
9	691081	cable, boom support, 1/8" x 20'	1	56	501541	screw, 5/16"-18 x 3 1/2", hex head	3
10	872086	Parts Pack C	1	57	501543	screw, 5/16"-18 x 5", hex head	4
11	872095	trap, 10 meter, Director	2	48	502898	#10-24 x 1", hex head	12
12	872097	boom tube assembly, beta	1	59	506305	screw, 1/4"-20 x 1 1/4", round head	4
13	872098	boom tube assembly	1	60	506325	screw, 1/4"-20 x 3/4", hex head	52
14	872394	Parts Pack D	1	61	506485	screw, #10-24 x 1/2", round head	5
15	872645	tubing bundle	1	63	506741	screw, 5/16"-18 x 2 3/4" hex head	2
16	175165	D3-3, 7/16" x 52"	2	64	506195	screw, 3/8"-16 x 2", hex head	2
17	190308	D3-2, 1 1/8" x 32 1/2", swaged 1/8"	2	65	506290	screw, 1/4"-20 x 2 1/2", round head	2
18	190900	D3-1, 1 1/4" x 48"	2	66	516470	screw, #10 x 1/2", Type A, round head	1
19	872646	tubing bundle	1	67	505540	screw, 1/4"-20 x 3/8", hex head	12
20	175165	D2-3, 7/16" x 52"	2	68	555362	nut, #10-24 square	36
21	190006	D2-2, 5/8" x 26"	2	69	556945	nut, 5/16"-18 hex jam	9
22	190206	D2-1, 3/8" x 55"	2	70	556960	nut, 1/4"-20 hex	60
23	872647	tubing bundle	1	71	556970	nut, #10-24 hex	7
24	174865	D2, 7/16" x 48"	2	72	558137	nut, 3/8"-16 hex	2
25	174861	D1, 3/8" x 53", swaged 7/16"	2	73	558685	nut, 1/4" square	12
26	872648	tubing bundle, DE	1	74	567080	lockwasher, 5/16" split	9
27	178558	DE4, 7/16" x 28"	2	75	567085	washer, 5/16" flat	7
28	178414	beta tube, 3/8" x 38 3/4"	2	76	567095	lockwasher, 3/8" internal	2
29	190309	DE-2, 1 1/8" x 42", swaged 1/8"	2	77	567110	lockwasher, 1/4" internal	88
31	190900	DE1, 1 1/4" x 48"	2	78	567125	lockwasher, #10 internal	11
32	872649	tubing bundle, 10 meter Reflector	1	79	506435	screw, #10-24 x 2" round head	4
33	171154	R2-3, 7/16" x 39"	2	80	500095	#10-24 x 1 1/2", hex head	20
34	190006	R2-2, 5/8" x 26", swaged 7/16"	2				
35	190206	R2-1, 3/8" x 55", swaged 3/8"	2	10	872086	Parts Pack C contains the following:	
36	872650	tubing bundle, 15-20 meter Refl.	1	81	455625	caplug, 2"	2
37	171153	R-3, 7/16" x 37"	2	82	455644	caplug, 7/16"	12
38	190307	R-2, 1 1/8" x 38", swaged 3/8"	2	83	465595	insulator, beta support (bottom)	2
39	872091	R-1, 1 1/4" x 95 1/2"	2	84	465600	insulator, beta support (top)	2
40	879903	Parts Pack B	1	85	465833	insulator, Driven Element	2
41	879478	Parts Pack A	1	86	878561	pigtail leads	2
42	878637	trap, 15 meter Driven Element	2				
43	878694	trap, 15 meter	2	14	872394	Parts Pack D contains the following:	
44	878749	trap, 10 meter Driven Element	2	87	168695	clamp, 1 1/4" tubing	2
41	879478	Parts Pack A contains the following:		88	171149	clip, beta shorting	1
45	380284	compression clamp, 1/2"	12	89	381100	clamp, boom support, 1 3/4" I.D.	2
46	380285	compression clamp, 3/4"	4	90	381253	strap, boom support	2
47		(not applicable)		30	190607	DE3, 1" x 5"	2
48	380287	compression clamp, 1 1/4"	6				
49	380286	compression clamp, 1"	10				

When ordering replacement parts, be sure to include the product number (389), item code number, part number and the full description of the item.