

#### RADIATOR TO BOOM ASSEMBLY:

Loosely install two U-bolts (part 12) to element support (part 1) with lockwasher and nuts (parts 14 and 15). At this time attach ground strap (part 23) to one of the U-bolts. Place support (part 1) directly over blue color code mark on boom (part 26). Install clamping block (part 22) between element support (part 1) and boom (part 26). Secure nuts and lockwashers.

#### REFLECTOR ELEMENT ASSEMBLY - Color Coded Yellow

Element section (part 17) is factory pre-assembled. Center the holes in element (part 17) color coded yellow over yellow color code on boom (part 26). Place U-bolt (part 12) around yellow color code on boom (part 26), clamping block (part 13) and into the two holes in element (part 17). Secure U-bolt with nuts and lockwashers (parts 15 & 14). Telescope element section (part 18) color coded yellow into element (part 17) and align holes according to the desired frequency on frequency chart and secure with screws (part 11). Place trap assembly (part 19) color coded yellow into element (part 18), and secure with screws (part 11).

#### DIRECTOR ELEMENT ASSEMBLY - Color Coded Green

Element (part 20) is factory pre-assembled. Center the holes in element (part 20) color coded green over green color code on boom (part 26). Place U-bolt (part 12) around green color code on boom (part 26), clamping block (part 13) and into two holes in element (part 20). Secure U-bolt with nuts and lockwashers (parts 15 & 14). Place trap assembly (part 21) color coded green into element (part 20), align holes according to frequency chart and secure with screws (part 11).

#### BOOM TO MAST PLATE ASSEMBLY:

Center mast plate (part 27) over black color coded mark on boom (part 26). Place clamping blocks (part 22) between boom (part 26) and mast plate (part 27). Place U-bolts (part 12) around boom (part 26), clamping blocks (part 22) and into holes in mast plate (part 27) securing with nuts and lockwashers (parts 14 & 15). The remaining nuts, lockwashers, clamping blocks and U-bolts are for attaching the antenna to the mast.

A package of Mosley Antenna Coat has been included with this antenna. After antenna has been assembled, spray or brush antenna coat over entire unit and let dry before mounting on mast. Be sure antenna coat does not prevent good electrical contact between boom and mast.

NOTE: To order replacement parts from instruction sheet, refer to Form No., Mosley Part No. and Part no.

FREQUENCY CHART				
ELEMENT	COLOR	BAND	CODE I*	CODE II**
RADIATOR	BLUE	10 Meters	28.1	28.8
REFLECTOR	YELLOW	15 Meters	21.050	21.3
DIRECTOR	GREEN	20 Meters	14.050	14.275
*Best for CW			**Best for Phone	

**Mosley Electronics, Inc.**  
4610 N. LINDBERGH BLVD., BRIDGETON, MISSOURI

# ASSEMBLY INSTRUCTIONS

FOR

## MOSLEY THREE ELEMENT

## TIG-ARRAY ANTENNA

## MODEL MP-33

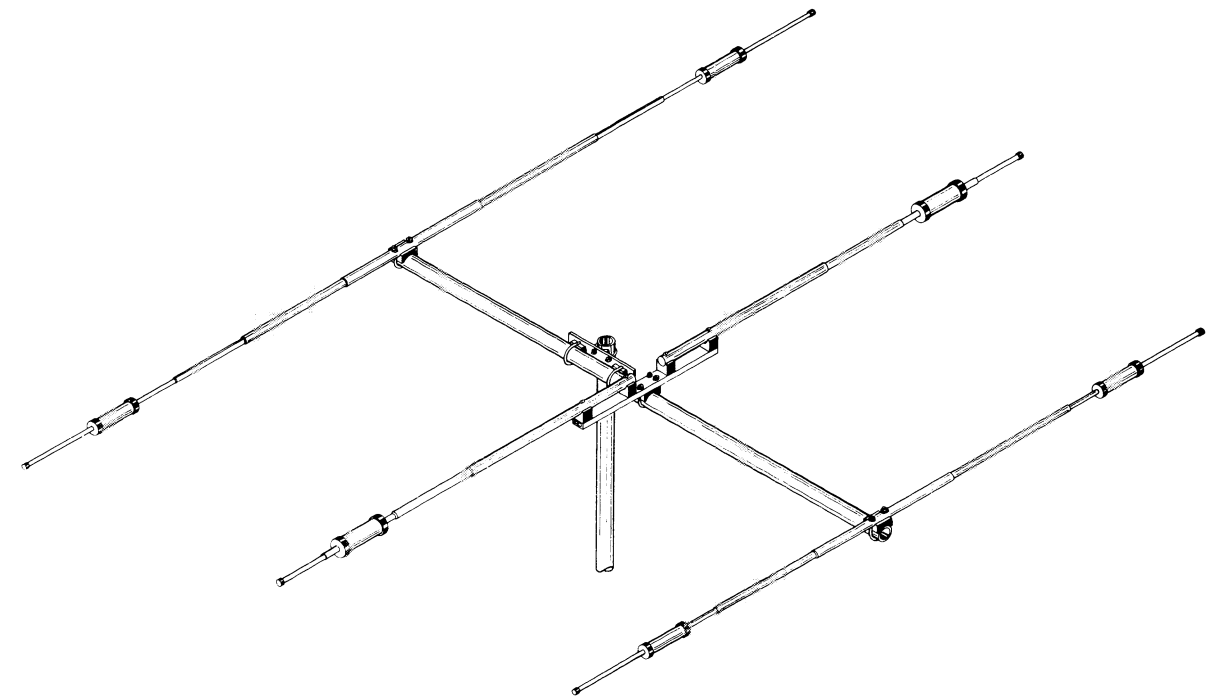

*The high performance of your MOSLEY Antenna can only be achieved if the antenna is assembled in accordance with instructions supplied. Substitution of materials or modification of design will materially lessen this performance.*

# Part List

MOSLEY PART NO.	QUAN.	PART NO.	DESCRIPTION
1001	1	1	Element support
1002	4	2	Insulators
1003	8	3	10-32 x 1 1/4" long, screws
1004	12	4	No. 10 Lockwashers
1005	4	5	10-32 x 1 3/4" long, screws
1006	2	6	1" OD x .058 wall, Element (coded blue)
1007	2	7	7/8" OD x .058 wall, Element (coded blue)
1008	2	8	Trap Assembly (coded blue)
1015	2	9	5/8" OD x .035 wall, Element (coded blue)
1016	2	10	5/8" Caplugs
1113	12	11	No. 6 x 3/8" long sheet metal screw
1018	8	12	U-bolts
1061	2	13	No. 41 Clamping blocks
1014	16	14	1/4" Lockwashers
1020	16	15	1/4-20 Nuts
1021	2	16	5/16" Solder Lug
1344	1	17	3/4" & 7/8" OD x .058 wall, Element (coded yellow)
1283	2	18	5/8" OD x .058 wall, Element (coded yellow)
1275	2	19	Trap assembly (coded yellow)
1346	1	20	5/8" & 3/4" OD x .058 wall, Element (coded green)
1278	2	21	Trap assembly (coded green)
1266	5	22	No. 44 Clamping blocks
1034	1	23	Ground strap
1036	2	24	1" Metal caps
1267	2	25	1 1/4" Metal caps
1280-1	1	26	Boom 1 1/4" x 12' long
1030	1	27	Mast plate



**METAL CAPS (24)**  
Modify each of the two smaller plug-caps by bending in any two opposite tines, as shown.

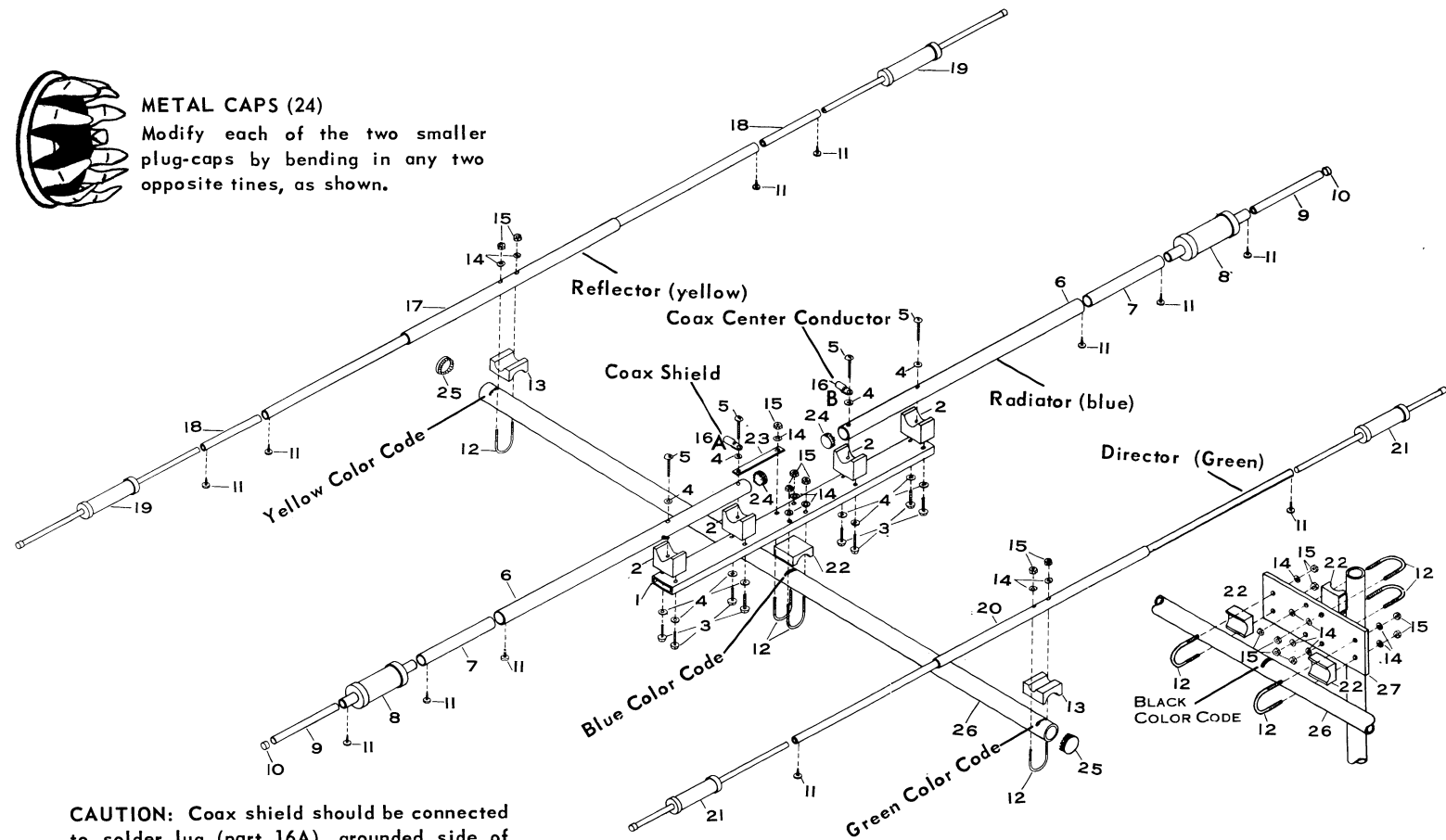

**CAUTION:** Coax shield should be connected to solder lug (part 16A), grounded side of antenna; Coax center conductor should be connected to solder lug (part 16B).

## Assembly

**CAUTION:** Coil assemblies are color coded on one end only; this color code should always be nearest the boom. Reversal of traps will cause high SWR and other malfunction of beam. The coding on the adjusting holes may be determined from the frequency chart. Adjusting holes do not appear on the reflector trap assembly (yellow) and radiator trap assembly (blue), but on elements sections (parts 18&7).

All trap assemblies are provided with breather holes and should face down.

The reflector and director trap assemblies have a 1/2" plastic cap on one end, indicating that it is the outside end of the element and a moisture seal. **DO NOT REMOVE!**

Begin assembly by grouping all elements and coil sections according to color code. For proper matching, RG8/U 52 ohm coax is recommended.

**NOTE:** This Mosley beam is supplied with an anti-corrosion compound that prevents the formation of high resistance corrosion. Apply compound between coupled tubing sections. Elements will not telescope without it.

### RADIATOR ELEMENT ASSEMBLY- Color Coded Blue

Loosely install insulator (part 2) to element support (part 1) with screw and lockwasher (parts 3 and 4). Place element section (part 6) into "V" of insulator (part 2) so that screw hole on blue color coded end of element (part 6) is facing down. This is important to assure proper position of the coil assemblies that are provided with breather holes and should face down. Place screw (part 5) through lockwasher (part 4) and secure to outermost insulator (part 2). Place screw (part 5) through solder lug (part 16A), lockwasher (part 4), ground strap (part 23), element (part 6) and secure to insulator (part 2). Insert screw (part 5) through solder lug (part 16B), lockwasher (part 4), element (part 6) and secure all insulators. Insert blue color coded end of element section (part 7) into corresponding color coded end of element (part 6). Align holes according to frequency chart and secure with screw (part 11). Insert blue color coded end of trap assembly (part 8) into element section (part 7) and secure with screw (part 11). Insert blue color coded end of element section (part 9) into end of trap assembly (part 8) and secure with screw (part 11). Place plastic cap (part 10) over ends of element sections (part 9) and press metal cap (part 24) into inboard ends of radiator element (part 6).

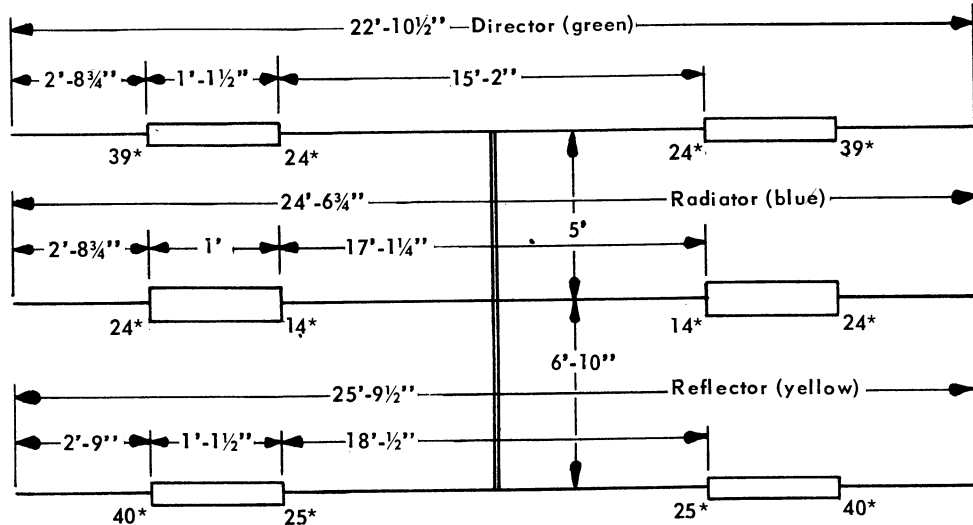

Settings are for Code II, add 10 1/2" to center dimension for Code I.  
\* Indicates number of coil turns.