

5:DMTG

DIGITAL MULTIMETER

MODEL IMD 202

TROUBLESHOOTING GUIDE



BELL & HOWELL SCHOOLS

TABLE OF CONTENTS

Introduction to Test Procedures	1
Section A, DC Voltage Off	3
Section B, AC Voltage Off	6
Section C, DC Current Off	11
Section D, AC Current Off	12
Section E, Ohm's Off	14
Section F, Meter Completely Inoperative	18
Nixie Tube Check	20
BCD Converter Check	21
JK Flipflop Check	23
Decade Counter Check	25
Pulse Shaping Check	26
Oscillator Check	28
Oscillator Switch Check	29
Ramp Generator Check	32
Section G, Power Supply	36
Figure Section	APPENDIX A
Wire Check List	APPENDIX B
Report Form	APPENDIX C

TROUBLESHOOTING MANUAL
FOR THE
BELL & HOWELL SCHOOLS DIGITAL MULTIMETER

The DMM is a quality instrument which should provide trouble free operation for many years. However, problems will sometimes occur. To assist you in clearing any problem and returning the meter to proper operation as soon as possible, we have prepared this troubleshooting guide. In addition, following the troubleshooting procedures outlined in this manual should be helpful in aiding you to develop a sense of general troubleshooting techniques. Because of the nature of digital equipment, the oscilloscope is a valuable troubleshooting tool which you may use if available. We are aware that an oscilloscope is not always available. Therefore, the procedures in this manual can be completed without an oscilloscope.

Introduction to Test Procedures

A list of general specifications is included in the construction manual. In the case of marginal operation, as opposed to complete circuit failure, it is often a good idea to review the general specifications to insure that the problem is not due to improper usage of the DMM. A review of calibration procedures in the construction manual would be helpful. Much information about a possible problem can be obtained by following the calibration procedure.

In the assembly of test equipment, improper operation is caused by any of four factors. These are listed in the order found to be most common.

1. POOR OR UNSOLDERED CONNECTIONS.

Failure to apply either sufficient heat or solder to a connection results in a "cold solder" or rosin joint. This is commonly found where two or more wires connect to one lug. Such a connection causes a high resistance or open in the circuit. Unsoldered connections also produce these symptoms.

The application of too much solder is also troublesome. This can cause solder to run into switch contacts or allow a short circuit between two points.

2. FAILURE TO READ INSTRUCTIONS.

Failure to read instructions carefully and to note details, such as terminal point identification on the PC Board, method of connection and switch lug numbering, can cause wiring errors. Also, it permits improper placement of parts and connecting wires.

3. CARELESSNESS.

Many problems can be traced to carelessness such as reading color codes on resistors incorrectly or allowing your soldering iron to burn insulation which can result in a short.

4. FAULTY COMPONENT.

Although parts pass through several inspections before reaching you, manufacturing faults are sometimes overlooked. Of course, careless handling of parts, such as applying undue pressure or too much heat when soldering, can also cause damage.

Before checking wiring or components, carefully examine your soldered connections. A "cold" solder joint can be very misleading and hard to find. To insure that each wire is properly soldered, grasp the wire or component lead near the connection with your long nose pliers. Gently tug on the wire and move it from side to side. Observe the wire end in the connection to see if any free movement takes place. If it does -- reheat the connections. Also, make certain all connections are soldered. After you have examined your soldering, check resistors for proper coded value.

After checking solder connections, wiring should be checked. To assist you in checking the meter, a complete wire check list is enclosed. One fault often encountered is a short caused by two adjacent or crossed wires. This happens if the plastic insulation has been melted when soldering. Also, check all bare wires to be certain they are not shorted to adjacent lugs. Each wire should be traced from point to point. The simplified input circuit schematic diagrams in this manual are arranged to show the point to point physical arrangement of the wiring. Use them along with the wire check list accompanying this troubleshooting guide to check your wiring.

Remember, if the unit never worked properly, check wiring and component location first. Circuit board X-ray pictures are contained in the construction manuals. Use them to check component location. Be especially careful on the position of integrated circuits, transistors and diodes. Refer to the construction manuals for lead identification of semiconductors. Watch for diodes stamped with a part number which begins with the prefix "1N". It is easy to confuse the "1" with the band which marks the cathode end of the diode. A cathode band must completely encircle the diode.

Should a preliminary inspection fail to correct the problem, then a systematic troubleshooting method must be employed. Basically, this consists of two steps:

1. Determine the section in which the DMM trouble is located.
2. Locate the difficulty within that section.

This manual provides methods of checking each stage, working from the output towards the input to locate the faulty stage of the DMM. Once the faulty stage has been isolated, concentrated effort in troubleshooting the defective stage should enable you to locate the problem. You should keep notes of your results in case further technical assistance is required. The first step is to identify which of the following functions on your DMM do not work properly. The best method to check the individual functions is to calibrate the meter. If a function is calibrated properly, it is probably working satisfactorily. Go through the calibration procedure and check yes or no in the table below as you complete each function.

	<u>Yes</u>	<u>No</u>	<u>Section</u>
Works on dc voltage	—	—	A
Works on ac voltage	—	—	B
Works on dc current	—	—	C
Works on ac current	—	—	D
Works on ohms	—	—	E

If the meter works on some functions, but not on others, refer to the proper section to troubleshoot the problem circuitry. Proper operation on any function would indicate that the A/D converter and logic circuits are working. If none of the functions work properly, a check of power supply voltages should be made. Below is a list of power supply test points and the proper voltages at these test points. Refer to circuit board X-ray pictures in the construction manuals for component location. Measure and record your readings for each test point in the space provided. Refer to this chart if you must contact the Instruction Department for assistance in troubleshooting your meter. All readings are referenced to circuit common (circuit board hole "M" or input Common jack).

Power Supply Voltage Chart

<u>Power Supply Voltage</u>	<u>Test Point</u>	<u>Tolerance</u>	<u>Actual Measured Value</u>
+5 VDC	Emitter, Q11	±10%	_____
+15 VDC	Cathode, D14	±10%	_____
-15 VDC	Anode, D15	±10%	_____
+110 VDC	Cathode, D16	±20%	_____

If power supply voltages are normal, refer to Section A. If not, refer to power supply troubleshooting, Section G.

Section A
DC Voltage Off, All Other Functions Normal*

This section of the troubleshooting guide will assist you in troubleshooting the dc input circuits. Before beginning the actual troubleshooting procedure, it may be helpful to review a few important facts.

*This section is also used when meter is completely inoperative.

The input to the A/D converter must be a dc voltage. The function of the input circuits is to convert whatever input function you select, dc or ac voltage, dc or ac current, or resistance measurements, to a dc voltage which the A/D converter can handle. As a result, the first step in calibrating the meter is to set up the dc voltage readings. This is also the first step to check in the event of a defective meter. If you will refer to the block diagram of the meter (Fig. 1) which is contained in this manual, you will see that the input circuits all feed the A/D converter. The first step in troubleshooting is to determine if the problem exists within the input circuits or in the A/D converter or beyond. Test 1 of this section determines whether the problem is with the input circuits or with the A/D converter.

Test 1

To perform this check you will need a 1.5 volt D-cell battery and about 12 inches of number 22 hookup wire, 6 inches of red and 6 inches of black. To prepare the battery, solder the 6 inch black wire to the negative terminal of the battery. Solder the 6 inch red wire to the positive terminal of the battery. Solder the black lead from the battery to the black wire coming from circuit board hole M. Simply tack solder this connection as it will be removed shortly. Next, unsolder the white wire from terminal 1R on the rear deck of the function switch, SW1. The other end of this white wire should be connected to circuit board hole A. Make sure that you select the proper wire and connections.

Step 1. Making sure that none of your temporary connections touch any other part of the printed circuit board, function or range switches, plug in the meter and turn it on to any range and any function. Turn the range and function switches through all positions. The meter should indicate "Over .85" (variable with the oscillator adjust control) in all positions of the range and function switches except the "OFF" position of the function switch.

Step 2. With the meter operating, touch the red wire from the battery to the white wire which is attached to circuit board hole A. With the red wire from the battery touching the white wire from circuit board hole A, the meter should indicate "150", plus or minus 50 digits. Disregard the location of the decimal point.

Analysis

There are three possible results of Test 1. The first is that no reading at all could be obtained any time during the test. If this is the case, proceed directly to Section F of this manual. Another possibility is that the readings were exactly as specified in Test 1. If this is the case, proceed directly to Test 2. Thirdly, if different readings were obtained from those specified in Test 1, proceed to Test 3. At this point, you should reconnect the white wire from circuit board hole A to lug 1R on the function switch, SW1, rear deck.

Test 2

The results of Test 1 indicate that the input circuits appear to be defective. To assist you in troubleshooting the input circuits, a simplified schematic diagram of the dc volts input circuits is included. Refer to the diagram labeled, "DC Volts".

Notice that there is a direct current path from the input connection, the red wire connected to terminal 7F on the function switch, SW1, front deck, to circuit board hole A when the range switch is set to the "2" position. As the range switch is rotated from the "2" position to the "2K" position, resistors R104 through R101 are added to the circuit. This test will insure these resistors and connections are properly made.

- Step 1. Make sure the meter is unplugged. Set the function switch to the "DC V" position and the range switch to the "2" position. Using the small multimeter (VOM) you received in your first laboratory shipment on the lowest resistance range, measure the resistance from lug 7F on the front deck of the function switch, SW1, to lug 1R on the rear deck of the function switch, SW1. You should achieve a zero ohm reading.
- Step 2. Set the range switch of your digital multimeter to the "2K" position. Set your VOM to a range suitable to measure 1,000 ohms. Measure the resistance from lug 1R on the rear deck of the function switch, SW1, to circuit board ground at hole M. A 1,000 ohm reading should be achieved.
- Step 3. Set the range switch of your digital meter to the "200" position. Select a range on your VOM to measure 10,000 ohms. Measure the resistance from lug 1R on the rear deck of the function switch, SW1, to circuit board ground at hole M. A reading of 10,000 ohms should be achieved.
- Step 4. Set the range switch of your DMM to the "20" position. Select a range on your VOM to measure 100,000 ohms. Measure the resistance from lug 1R of the function switch to circuit board ground, hole M. The reading should be approximately 100,000 ohms.
- Step 5. Measure the resistance between lug 18R of the rear deck of the range switch to lug 16R of the rear deck of the range switch. An approximate reading of 1 megohm should be achieved.

Analysis

Failure to obtain the proper resistance reading for any of the Steps 1 through 5 above indicates a wiring error in the meter. Use the simplified wiring schematic and the multimeter wiring check list to locate and correct any errors.

Test 3

The procedures of this test should be used only if the results of Test 1 were other than the two specified. The "Over .85" reading is an indication of the operation of the internal oscillator of the digital meter. The "150" reading is an indication of the operation of the A/D converter. Since the oscillator is tested first, we will first test to see whether or not the oscillator needs repair.

- Step 1. Set up the meter exactly as specified in Step 1, Test 1 of Section A. Observe the meter reading. Vary the oscillator adjust control, R207, for an "Over .85" reading. If you are unable to obtain an "Over .85" reading, refer to Section F.
- Step 2. Set up the meter and test battery as outlined in Step 2, Test 1 of Section A. Holding the red lead from the test battery in contact with the white lead from circuit board hole A, vary the dc calibration control, R146, to attempt to achieve the specified "150" reading.
- Step 3. If the results of steps 1 and 2 were satisfactory, resolder the white wire to lug 1R of the function switch rear deck, and return to Test 2 of Section A. If the proper results were not achieved in Step 2, refer to Section F.

Section B AC Voltage Off, All Other Functions Normal

Section B covers difficulties with ac voltage readings and includes a circuit description of the ac converter. Since the A/D converter operates on dc voltages only, it is important that you insure that the meter is operating properly for dc voltages before any attempt at troubleshooting in the ac converter. If you are not sure whether or not the dc function is operating, repeat the dc calibration procedure as outlined in your construction manuals. If you cannot properly calibrate the dc function, refer to Section A of this troubleshooting guide. To assist you in understanding the ac input circuits and as an aid in troubleshooting, a simplified schematic diagram of the ac input circuits has been provided. This diagram is in the figure section of this manual, labeled "AC Volts".

The ac converter converts an rms ac voltage to a dc voltage equal in amplitude to the rms value of the applied input voltage. The dc output voltage of the ac converter is applied to the A/D converter. The voltage divider network used for the dc function of your meter is also used for the ac function. The function switch directs the ac input voltage to the ac converter and connects the output of the ac converter to the A/D converter. The input voltage divider is designed so that the voltage applied to the input of the ac converter is between zero and 2 volts rms, provided the maximum value indicated by the range switch setting is not exceeded. When the function switch is in the "AC V" position, the portion of the input voltage selected by the range switch is applied to circuit board hole D.

Referring to the schematic diagram, the signal path from circuit board hole D is through isolation capacitor C103 to the gate of Q8. Q8, a field effect transistor connected as a source follower, provides an impedance match between the high impedance input circuits and the low input impedance of the operational amplifier, IC1. Diodes D5 and D4 provide over voltage protection for the field effect transistor. Notice that the cathode of D4 is held at positive 5 volts dc through voltage divider R134 and R139. The anode of D5 is

held at negative 5 volts dc through voltage divider R136 and R135. If the input voltage exceeds 10 volts peak to peak ac, diodes D4 and D5 conduct on the positive and negative going peaks and limit the signal applied to the gate of Q8 to 10 volts peak to peak.

From the source of Q8, the signal is coupled directly to the input of IC1. Diodes D7 and D8 provide input protection for the integrated circuit. They form a diode clamp circuit which limits the emitter-base voltage of the input transistors of the IC to the forward voltage drop of the protection diodes. If the diodes were not used, the input signal could be of sufficient amplitude to reverse bias the emitter-base junctions of the integrated circuit input transistors and cause damage to these transistors.

The output of integrated circuit IC1 is coupled by C111 to the rectifier/feedback network consisting of diodes D8 and D9 as well as resistors R154, R155, R156 and R167. The actual feedback voltage applied to the inverting input of integrated circuit IC1 is developed across R156 and R167. Diode D9 conducts on the positive going portion of the output signal and diode D8 conducts on the negative going portion of the output signal. Since both diodes have a common current path through resistors R156 and R167, a sine wave is coupled across capacitor C112 to the inverting input of the integrated circuit to serve as feedback. The amount of feedback and thus the amplitude of the output signal is controlled by varying resistor R167, the ac calibration control. The dc output voltage is developed at the junction of D9 and R155. Since diode D9 conducts only on the positive half cycle, the voltage at the junction of D9 and R155 has an average positive value with respect to ground. This average value is filtered by the network consisting of R129, R128, C104 and C102. The charge across capacitor C102 is a dc voltage equal to the rms value of the ac input voltage to the ac converter. From circuit board hole C, this dc voltage is routed through the function switch to circuit board hole A and the A/D converter.

The troubleshooting procedure consists of four tests. These will cover the input circuits, the impedance matching amplifier, Q8, the operational amplifier, IC1, and the feedback/rectifier circuit, D8 and D9. Complete these tests in numerical order and, for any tests which do not come out as expected, follow the instructions given in the analysis of each test.

Test 1

Test 1 covers the input circuits.

Step 1. Making sure the meter is unplugged, set the function switch to the "AC V" position and the range switch to the "2" position. The simplified schematic of the ac voltage section of the meter shows that, when the range and function switches are set to these positions, there is a direct current path between the red input jack and circuit board hole D of the printed circuit board. Set the small multimeter (VOM) you received in your first lab shipment to its lowest resistance range. Measure the resistance from lug 7F on the function switch, SW1, to circuit board hole D. A reading of zero ohms should be obtained.

- Step 2. Measure the resistance between circuit board hole C and circuit board hole A. A zero ohm reading should be obtained.
- Step 3. Set the range switch of the digital multimeter to the "20" position. Select a range on the VOM to measure 100,000 ohms. Measure the resistance from circuit board hole D to circuit ground (circuit board hole M). A reading of approximately 100,000 ohms should be obtained.
- Step 4. Set the range switch of the digital multimeter to the "200" position. Select a range on the VOM to measure 10,000 ohms. Measure the resistance from circuit board hole D to circuit ground (circuit board hole M). A reading of approximately 10,000 ohms should be obtained.
- Step 5. Set the range switch of the digital multimeter to the "2K" position. Select a resistance range on the VOM to measure 1,000 ohms. Measure the resistance between circuit board hole D and circuit ground (circuit board hole M). A reading of approximately 1,000 ohms should be obtained.

Analysis

Failure to obtain the proper readings in Steps 1 through 4 of Test 1 indicates a wiring error in either the function or range switches of your meter. Use the simplified ac voltage input schematic and the wiring check list included with this manual to double check your wiring. You may find one or more wiring errors which, when corrected, will result in proper operation of the meter. Note: If the ac function of your meter works on the "2" range but does not work on any other range, check the value and wiring of resistor R104.

Test 2

Once the input circuits have been tested, check the signal path through the ac converter circuit itself. First, check the impedance matching amplifier, field effect transistor Q8.

- Step 1. Plug in the digital multimeter and set the function switch to the "AC V" position. Set the range switch to the "20" position. Plug in the Electro-lab Design Console and connect the input of your digital multimeter to the 12.6 volt ac transformer windings. These are binding posts number 11 and 7 of your design console. Set the On-Off switch of the design console to the 6 volt position. Use the VOM to measure the ac voltage at the input terminals of the digital multimeter to insure that 12.6 volts is applied.
- Step 2. Measure the ac voltage at the source of transistor Q8 with the VOM. A reading of approximately .5 volts ac should be obtained. If this reading is not obtained, turn off the meter, remove IC1 from the socket, turn on the meter and repeat the measurement at the source of Q8. If the reading

of .5 volts ac is obtained, replace IC1. If no reading is obtained in either step, refer to the analysis at the end of this test. Note: Because of the high impedance of the gate circuit of transistor Q8, readings with a low ohms/volt rating meter, such as the VOM, are invalid. Voltage measurements at the gate of Q8 can be made if a meter with a 10 megohm input impedance is used. Signal voltage should be approximately 1.2 V rms. Correct dc voltage readings are on the schematic.

Analysis

Failure to obtain the proper voltage measurements at the source of transistor Q8 indicates a break in the signal path between circuit board hole D and the input to the operational amplifier. Referring to the schematic diagram of the meter, we can see that there are only a few components in this signal path. Transistor Q8 can be removed from the circuit and checked with a standard resistance check for junction field effect transistors. Proper operating voltages on the source and drain can be checked using the VOM. However, gate voltage measurements should not be made as they are meaningless due to the loading effects of a low ohms/volt VOM. A visual inspection of the components, especially diodes D4 and D5, can reveal mislocated, misarranged or damaged components. Resistance tests can reveal if diodes D4 or D5 are defective or mislabeled. If the results of Test 2 were satisfactory, leave the meter and design console set up as outlined in Step 1 and go on to Test 3.

Test 3

The next step in the signal path through the ac converter is the operational amplifier, IC1. Note: If IC1 was removed in Test 2, replace it in the circuit at this time. Make sure the meter is turned off when removing or replacing IC's.

- Step 1. The meter and design console should be set up as outlined in Step 1 of Test 2. Using the VOM to measure 15 volts dc, measure the voltage at pin 7 of IC1. A reading of +15 volts dc should be obtained. Next, measure the dc voltage at pin 4 of IC1. A reading of -15 volts dc should be obtained.
- Step 2. Measure the ac voltage at pin 3 of IC1. A reading of 0.5 volts ac should be obtained.
- Step 3. Measure the ac voltage at pin 6 of IC1. A reading of 5 volts ac should be obtained. The ac voltage reading at pin 6 of IC1 is controlled by the ac calibration control. Vary the ac calibration control and see if the reading at pin 6 will vary.

Analysis

Failure to get the proper dc voltage readings in Step 1 of this test may indicate a problem in the power supply. Remove the integrated circuit to eliminate the possibility of loading effects. Remeasure the voltages at the socket of the integrated circuit, pins 7 and 4. If the proper voltages are not obtained, troubleshoot the ± 15 volt supply as indicated by the results of your tests. Failure to get the proper ac voltage readings in steps 2 and 3 probably indicates a problem with the integrated circuit. Replace the integrated circuit. Note: If the voltage is available at pin 6 of IC1 but you cannot vary it with the ac calibration control, proceed to Test 4 before replacing the integrated circuit. Leave the digital multimeter and design console set up as the same set up will be used in Test 4.

Test 4

This test checks the operation of the feedback/rectifier network which provides the dc voltage to the A/D converter as well as the feedback to control the gain of integrated circuit IC1.

- Step 1. The design console and digital multimeter should be set up as outlined in Step 1 of Test 2. Using your multimeter, measure the ac voltage at the cathode of diode D9. A reading of 2 to 2.5 volts ac should be obtained. This reading should be variable with the ac calibration control. To check the feedback portion of this circuit, measure the ac voltage at the anode of D8. This voltage reading should be equal to the ac voltage reading at the cathode of D9 and should also vary with the setting of the ac calibration control.
- Step 2. While measuring the ac voltage at D9 cathode, set the ac calibration control so that the ac voltage at the cathode of D9 is between 2 and 2.5 volts ac. Next, measure the dc voltage at the cathode of D9. You should obtain a reading of approximately 1.5 volts dc. Next, measure the dc voltage at circuit board hole C. Due to loading effects, you will notice only a slight deflection of the meter.

Analysis

Failure to obtain any of the readings mentioned in Steps 1 and 2 indicates a defective component or wiring error in this portion of the circuitry. The diodes may be checked by removing them from the circuit and conducting a standard resistance check. Resistance checks can be conducted on the other components in the circuit. Replace any damaged, defective or off value components.

If you are unable to find the problem in the ac converter section on your own, record the voltage readings you obtained in Tests 1 through 4 above on a separate sheet of paper and submit this with the Report Form to the school with a complete description of the problem.

Section C
DC Current Off, All Other Functions Normal

This section covers difficulties with dc current readings. The digital multimeter makes direct current readings by passing the unknown current through a known precision resistor. The voltage drop across the resistor is then measured. The circuit is designed so that if the unknown current applied to the inputs of the meter is within the range specified by the particular setting of the range switch, a voltage drop between zero and 2 volts dc will be felt across the selected precision resistor. This zero to 2 volt drop is applied directly to the A/D converter. Since current readings depend upon proper operation of the A/D converter, proper operation should be determined before any attempts are made to troubleshoot the dc current functions. The best method is to attempt the dc voltage calibration procedure. If proper calibration cannot be obtained, refer to Section A of this manual. To assist you in troubleshooting, a simplified schematic of the dc mA input circuits is provided. If your problems are restricted solely to dc current measurements, they must be caused by defects in the input circuits.

Test 1

When making current measurements, make sure that the red test lead is connected to the white, "mA, Ohms" input jack and that the black test lead is connected to the black, "C" input jack.

- Step 1. Remove fuse, F1, from its holder on the printed circuit board. Using the small multimeter (VOM) you received in your first laboratory shipment, measure the resistance of the fuse. A reading of zero ohms should be obtained. If a zero ohm reading is obtained, insert the fuse in its holder on the circuit board. If not, place a new fuse of the same value in the circuit board holder.
- Step 2. Set the range switch of your digital multimeter to the "200 ohm" position. Set the function switch to the "DC mA" position. Using the VOM, measure the resistance from the white, "mA, Ohms" input jack to circuit board hole A. A reading of zero ohms should be obtained.
- Step 3. Leaving the meter set up as in Step 2, measure the resistance from the white, "mA, Ohms" input jack to lug 1R on the rear deck of the range switch, SW2. A zero ohm reading should be obtained. Refer to Section D, "AC Current Off", Test 1. Complete Steps 5 through 8 of this test.

Analysis

Step 1 insures that the fuse used to protect the meter is okay. If the fuse is consistently blown, it is an indication that you are exceeding the maximum current limits for the particular range you are using. You should review the specifications for the meter and the operating procedure

contained in the construction manual. Step 2 checks for proper function switch wiring. Failure to get the proper readings in Step 2 indicates a wiring error in the function switch. Step 3 checks the wiring of the range switch and the condition of the precision resistors. Failure to get the proper results in Step 3 indicates either a wiring error or a problem with a particular resistor. Use the simplified schematic and wire check list to double check for wiring errors. Defective resistors should be replaced.

Section D AC Current Off, All Other Functions Okay

Section D covers difficulties with ac current readings when all other functions are operating normally. Proper calibration implies that the meter is working normally for these functions. If the ac voltage or dc voltage functions do not calibrate properly, refer to the appropriate sections of this troubleshooting guide and troubleshoot these areas first. Proper ac current readings depend upon proper ac and dc voltage readings.

The digital multimeter performs current measurements by routing the unknown current through a known precision resistor and measuring the voltage drop across this resistor. The same set of precision resistors used for dc current measurements are used for ac current measurements. The circuit is designed so that, if an alternating current is applied to the meter within the limits of the range switch setting which is being used, the rms voltage drop across the precision resistor will be some value between zero and 2 volts rms. To assist you in understanding the operation of the ac current function, a simplified schematic diagram of the ac current input circuits has been provided in this manual. Refer to the diagram labeled, "AC mA". The proper settings of the range and function switches allow the unknown current to be passed through one of the precision resistors, R106 through R109. The voltage drop across this resistor is then routed to the ac converter. A complete description of the ac converter is contained in Section B. However, satisfactory calibration of the ac voltage section clears the ac converter as a source of the problem in ac current measurements.

Over current protection is provided by fuse F1.

Since the ac converter has already been checked in the ac voltage calibration procedure, difficulty with the ac current section is restricted to the input sections. The following test will determine where the problem lies.

Test 1

When making any current measurements, make sure that your red test lead is connected to the white, "mA, Ohm" input jack.

Step 1. Remove fuse F1 from its socket and measure the resistance of the fuse using the small multimeter (VOM) you received in your first lab shipment. A reading of zero ohms should be obtained. If the reading is satisfactory, replace the fuse in its holder on the circuit board. If a reading other than zero ohms is obtained, place a new fuse in the fuse holder.

- Step 2. Unplug the meter. Set the range switch to the "200 ohms" position and the function switch to the "AC mA" position. Using your VOM, measure the resistance from the white, "mA, Ohms" input jack to circuit board hole D. A reading of zero ohms should be obtained.
- Step 3. Leaving the meter set up as in step 2, measure the resistance between the white, "mA, Ohms" input jack to lug 1R on the rear deck of the range switch, SW2. Again, a reading of zero ohms should be obtained.
- Step 4. Measure the resistance between circuit board hole C and circuit board hole A. A reading of zero ohms should be obtained.
- Step 5. Set the range switch to the "2" position. Measure the resistance from the white, "mA, Ohms" input jack to circuit board ground (the black, common terminal or circuit board hole M). A reading of 1,000 ohms should be obtained.
- Step 6. Set the range switch to the "20" position. Measure the resistance between the two points outlined in Step 5. A reading of 100 ohms should be obtained.
- Step 7. Set the range switch to the "200" position. Measure the resistance between the two points outlined in Step 5. A reading of 10 ohms should be obtained.
- Step 8. Set the range switch to the "2K" position. Measure the resistance between the points outlined in Step 5. A reading of 1 ohm should be obtained.
Note: Because of the low resistance, the meter may read zero. For the time being, this will be acceptable.

Analysis

Step 1 checks the fuse. If the fuse was open, it is an indication that you exceeded the maximum current specifications for the meter. It is suggested that you review the specifications and the proper operating procedure for the meter in the construction manual to prevent a re-occurrence of this problem.

Steps 2 through 4 check the wiring of the function switch. If proper results are not obtained in these steps, refer to the simplified wiring diagram and the wiring check list to locate the wiring errors, which, when corrected, will result in satisfactory operation.

Steps 5 through 8 check the precision resistors and wiring of the range switch. Failure to get the proper readings indicates a wiring error or an improper value resistor. Refer to the simplified schematic to determine the particular resistor and connections.

Section E
Ohm's Off, All Other Functions Okay

This section of the troubleshooting guide deals with problems within the ohmmeter function of your meter. A review of basic circuit operation and detailed troubleshooting instructions are included.

To assist you in understanding the operation of the ohmmeter function of your digital multi-meter, a simplified schematic diagram of the input circuits has been provided in the figure section of this manual. Refer to the figure entitled, "Ohm's". Resistance measurements are made by applying a constant current to an unknown value of resistance. The voltage drop across the unknown resistor is thus proportional to the value of resistance only. The voltage drop across the unknown resistance is applied to the A/D converter. The circuit is designed so that the voltage drop across the unknown resistance will be between zero and 2 volts dc if the value of the unknown resistance is less than the setting of the range switch.

The constant current source consists of transistors Q9, Q10 and their associated circuitry. A simplified schematic diagram of the constant current source is shown below.

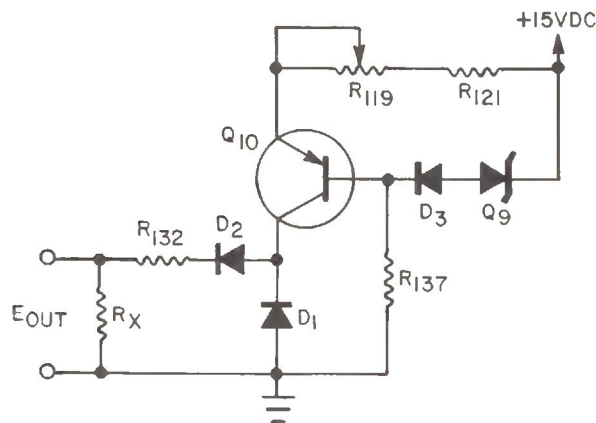

OHM'S CONSTANT CURRENT SOURCE

Notice that transistor Q9 is shown as a zener diode. Q9 provides a constant base voltage for transistor Q10. The actual base voltage of transistor Q10 is equal to the sum of the forward bias voltage drop across diode D3 and the avalanche breakdown voltage drop from base to emitter of transistor Q9. Normally, this voltage drop is about 8 volts dc, resulting in a Q10 base voltage of 7 volts dc with respect to ground. With a constant voltage at the base of Q10, Q10 base current depends upon the value of resistors R119, R121, and Q10 base-emitter

forward bias resistance. With a constant base current, Q10 collector current will also be constant. The base and collector current can be varied by adjusting the value of R119. Q10 collector current flows through the unknown resistor RX. Since collector current is fixed, the output voltage will depend upon the value of RX. When the value of RX is 200 ohms, resistor R119 is adjusted so the output voltage is exactly 2 volts dc. For any value of RX between zero and 200 ohms, the voltage drop across this resistor will be between zero and 2 volts dc. The output voltage is read directly as resistance in ohms on the display of the meter.

Diodes D2 and D1 provide protection for the constant current source. If the meter probes are accidentally touched to a negative source of potential, diodes D1 and D2 will be forward biased and the collector of transistor Q10 will be clamped at -.6 volts with respect to ground. This will prevent excessive current through the transistor, which could cause transistor failure. On the other hand, if the probes are touched to a positive source of potential, diodes D2 and D1 will be reverse biased, again preventing excessive current flow in the circuit.

The simplified schematic shown in this section of the troubleshooting guide is for the "200 Ohm" position of the range switch only. To increase the range of the meter, a decrease in the amount of current supplied to the unknown resistance is required. This is accomplished by selecting higher values of emitter resistance in the Q10 circuit. The value of the emitter resistor is selected so that the voltage drop across the unknown resistance will be equal to 2 volts dc if the value of resistance is equal to the setting of the range switch. To compensate for variations in transistor gain, the value of the emitter resistance is adjustable. In addition, precision resistors are provided for calibrating the ohms constant current source. Below is a table showing the output current supplied by the constant current source for each setting of the range switch.

<u>Range Switch Setting</u>	<u>Output Current</u>
"200 Ohms"	10 Milliamperes
"2"	1 Milliampere
"20"	100 Microamperes
"200"	10 Microamperes
"2K"	1 Microampere

The above table indicates that, in the lower resistance ranges of this meter, a large current is supplied by the constant current source. You should keep this in mind when using the DMM to check transistors. Resistance checks on semiconductor devices should be limited to the three highest resistance ranges of your meter, the 20K ohm, 200K ohm, and 2000K ohm ranges, to avoid damage to semiconductor devices.

The troubleshooting section is divided into two tests. The first test checks the input and switching circuits and the second test checks the constant current generator. Before proceeding, you should double check to make sure that the meter calibrates properly on dc. Since resistance measurements depend upon proper dc voltage measurements, you should verify that the dc voltage readings are accurate before proceeding with troubleshooting in the ohms section. If proper calibration of the dc section cannot be accomplished, refer to Section A of this manual.

Test 1

- Step 1. Unplug the meter. Set the function switch to the "K ohms" position and the range switch to the "200 ohm" position. Using the small multimeter (VOM) you received in your first laboratory shipment, measure the resistance from the white, "mA, Ohms" input jack to circuit board hole A. A reading of zero ohms should be obtained.
- Step 2. With the DMM set up as specified in Step 1, measure the resistance between the white, "mA, Ohms" input jack and circuit board hole F. A reading of zero ohms should be obtained.
- Step 3. If a zero ohm reading could not be obtained in either Step 1 or Step 2, remove fuse F1 from the holder on the printed circuit board. Measure the resistance of the fuse using your VOM. A reading of zero ohms should be obtained. If a zero ohm reading is obtained, replace the fuse in its holder on the printed circuit board.
- Step 4. With the DMM set up as outlined in Step 1, measure the resistance between circuit board hole E and circuit board hole G. A zero ohm reading should be obtained.
- Step 5. Set the range switch to the "2" position. Measure the resistance between circuit board hole E and circuit board hole N. A zero ohm reading should be obtained.
- Step 6. Set the range switch to the "20" position. Measure the resistance between circuit board hole K and circuit board hole E. A zero ohm reading should be obtained.
- Step 7. Set the range switch to the "200" position. Measure the resistance between circuit board hole J and circuit board hole E. A zero ohm reading should be obtained.
- Step 8. Set the range switch to the "2K" position. Measure the resistance between circuit board hole H and circuit board hole E. A zero ohm reading should be obtained.

Analysis

Steps 1 through 3 of Test 1 check the wiring of the function switch and the condition of the protective fuse used in the ohmmeter circuits. If either Steps 1 or 2 gave unsatisfactory results and Step 3 had satisfactory results, a wiring error is indicated. Use the simplified schematic diagram and wiring check list to find and correct the wiring error. If Step 3 had unsatisfactory results, replace the fuse with a known good fuse (measure it!) and repeat Steps 1 and 2. If satisfactory results are obtained, the meter should work. Note: Frequent blowing of F1 while in the ohms position indicates that you are not using the meter properly. Review operating procedures as outlined in the construction manual to avoid this difficulty.

Steps 4 through 8 check the wiring of the range switch. If unsatisfactory results were obtained in any of these steps, a wiring error is indicated. Again, use the simplified input schematic diagram and the wiring check list to find and correct the error.

Test 2

This test is designed to determine the operating condition of the constant current source. Do not attempt this troubleshooting procedure unless correct readings were obtained in Test 1 of this section. This test assumes that all wiring in the meter is correct. If wiring is not correct, the steps of Test 2 will not come out as expected.

- Step 1. Plug in the DMM. Set the function switch to the "K ohm" position and the range switch to the "2" position. Remove any test leads you may have connected to the input jacks of the meter.
- Step 2. Set your VOM to measure dc current on a range which will allow you to conveniently measure 1 milliampere. Place the black lead of your VOM in the "C" (black) input jack of your DMM. Touch the red lead of your VOM to the white, "mA, Ohms" input jack of the digital multimeter. You should obtain a reading of approximately 1 milliampere. If input jacks are not yet connected, use circuit board hole B for the red test lead, hole M for the black test lead.
- Step 3. Vary resistor R117, "2K ADJ", on the printed circuit board of your digital multimeter. You should be able to vary your current reading above and below 1 milliampere.
- Step 4. Leaving the DMM set up as outlined in Step 1, remove your VOM jacks from the input jacks of the DMM. Place the banana plug end of the black test lead supplied as part of your DMM kit into the white, "mA, Ohms" input jack and connect the alligator clip end to the ohms test point opposite resistor R126, the 2,000 ohm calibration resistor.

- Step 5. Using your VOM, measure the base and emitter voltages of transistor Q10. The base of Q10 should measure approximately 5.6 volts dc and the emitter of Q10 should measure approximately 6.3 volts dc.
- Step 6. Remove the alligator clip from the ohms test point. Again measure the base and emitter voltages of transistor Q10. The base voltage should increase to 7.0 volts dc and the emitter voltage should increase to 7.7 volts dc.

Analysis

Steps 1 through 4 check the output of the constant current generator. If proper output current was not obtained, Steps 5 through 7 check the operation of transistor Q10 and its associated circuitry. Failure to get the proper readings in any of the above steps can be caused by mislocated components, mismarked components, or defective components. The values of resistors can be checked with an ohmmeter. Likewise, transistors and diodes can be checked using resistance checks. Remember, resistance checks on individual components are only valid if they are taken out of the circuit.

Section F Meter Completely Inoperative

Section F should be used if you cannot obtain satisfactory operation on any range or any function of your meter. If this occurs, it is an indication that the problem with your meter exists in either the A/D converter or logic circuits. Before troubleshooting the individual stages, a review of the basic operation of this section of your multimeter is helpful. Detailed circuit descriptions of individual stages of the A/D converter and logic circuits are included in the individual checks.

Please refer to the DMM block diagram (Figure 1) contained in the figure section. The A/D converter circuitry is shown in the dashed line box marked "A/D CONVERTER". It consists of the ramp generator (Q1 through Q7), oscillator switch (IC2) and oscillator (Q12, Q15 and Q16). As stated previously, the function of the input circuits is to insure that a positive dc voltage between zero and 2 volts is applied to the input of the A/D converter. This zero to 2 volt dc voltage is applied to the ramp generator. The output of the ramp generator is a ramp signal (a ramp signal is a linearly increasing or decreasing dc voltage. It is similar to one half cycle of a sawtooth waveform.) The time duration of the ramp signal is directly proportional to the amplitude of the dc input voltage. The greater the dc input voltage, the longer the ramp. The oscillator switch, IC2, senses the beginning and end of the ramp. At the beginning of the ramp, the oscillator switch turns on the oscillator, Q15 and Q16, by cutting off transistor Q12. At the end of the ramp the oscillator switch turns off the oscillator by restoring forward bias to transistor Q12. Since the oscillator operates at a constant frequency, the number of pulses out of the oscillator is directly proportional to the time that the oscillator remains on. This, in turn, is controlled by the ramp generator which is controlled by the amplitude of the dc input voltage.

In order to display the value of the dc voltage applied to the input of the A/D converter, it is necessary to count the number of pulses out of the oscillator for each given sampling period and display the count as a decimal number. This is accomplished by the logic circuits, IC3 through IC8.

IC8, the pulse shaping/reset circuit, controls the operating mode of the logic circuits. The operation of the logic circuit is divided into two time periods, count time and display time. The duty cycle is derived from the 60Hz line frequency. Each time period is equal to the duration of one alternation. During count time, the A/D converter is enabled and, if a dc voltage is present at the input of the A/D converter, pulses from the oscillator are applied to the units decade counter, IC7. Because the 60Hz sample frequency and the anode voltage to the Nixie tubes are derived from the same halfwave rectifier, the Nixie tubes are not illuminated during count time. IC8 circuitry institutes count time during the negative alternation of the ac voltage applied to the halfwave rectifier. Consequently, the rectifier, D16, is reverse biased and no voltage is applied to the Nixie tubes. This is done to prevent the Nixie tubes from displaying the changing count as the decade counters operate.

During display time, the A/D converter is disabled and anode voltage is applied to the Nixie tubes. The Nixie tubes now display the count which was stored in the decade counters during count time. At the end of display time, IC8 generates reset pulses to prepare the logic circuits for the next count period.

The outputs of the decade counters are in binary coded decimal form. These outputs are applied to the BCD (binary coded decimal) converters, either IC3 or IC4. The BCD converters provide a ground path for the appropriate cathode of the Nixie tubes as determined by the binary coded decimal input.

Perform each of the following checks in the order listed until you reach a test that yields unsatisfactory results. This isolates the problem to the individual stage which you were checking. Further troubleshooting of the faulty stage should reveal the source of the problem.

1. Nixie tube check (V1 and V2)
2. BCD converter check (IC3 and IC4)
3. JK flipflop check (IC5)
4. Decade counter check (IC6 and IC7)
5. Pulse shaping check (IC8)
6. Oscillator check (Q12, Q15 and Q16)
7. Oscillator Switch check (IC2)

8. Ramp Generator check (Q1 through Q7)
9. If you are able to locate a defective component, use the blue and white parts order form that you received with the kit and order the part directly from Heathkit.
10. If you are unable to locate the problem, fill out the Report Form, Appendix C, and send it to the Instruction Department for review. Follow all instructions on the Report Form.

Nixie Tube Check
(V1 and V2)

Numbers on the Nixie tubes will light when the input signal to the tubes is at a low state. A low state to the proper inputs of each Nixie tube is provided by the BCD converters, IC3 and IC4. Shorting the inputs of each Nixie to ground will cause the corresponding digit to light. Refer to the schematic for the multimeter. The inputs to each Nixie tube are zero through nine. These correspond to the ten outputs of IC3 or IC4. For your convenience, the pins on the IC3 and IC4 sockets will be referred to in the following checks.

- Step 1. Remove IC4. The only digit lit should be zero on the "tens" Nixie tube. If the "units" Nixie tube shows a digit, check for shorts around the "units" tube socket.
- Step 2. Locate a test lead with spring adapters if available. Attach the banana plug end of the test lead to circuit board ground.
- Step 3. Using the other end of the test lead as a probe, short each of the inputs of Nixie V2, one by one, to ground. Access to V2 inputs can easily be obtained by shorting corresponding IC4 pin connections. For example, shorting pin 15 of the IC4 socket causes a "1" to light on the Nixie tube. Pins on IC3 and IC4 sockets that are also inputs to the Nixie tubes are:

<u>Inputs of Nixie Tube</u>	<u>IC3/IC4 Pin No.</u>	<u>Lighted Digit</u>
1	15	1
2	8	2
3	9	3
4	13	4

<u>Inputs of Nixie Tube</u>	<u>IC3/IC4 Pin No.</u>	<u>Lighted Digit</u>
5	14	5
6	11	6
7	10	7
8	1	8
9	2	9
0	16	0

Step 4. Repeat the above procedure for IC3 and V1.

Analysis

Removing IC3 or IC4 opens the current paths to the Nixie cathodes and you should not have a number displayed. A number displayed would indicate high resistance leakage on the circuit board or a solder short around the Nixie tube or IC sockets. A thorough check should be made before proceeding if any digit in the tube was lit.

You should note that when each pin of the IC3 or IC4 sockets listed in the chart was shorted to ground, the corresponding number was displayed on the Nixie tube. A digit not lit when shorting the input indicates possible opens in the foil or poor solder connections. A suspected Nixie tube should be interchanged with the other Nixie tube and the test repeated. If improper results are obtained, check both the Nixie tube and IC sockets.

BCD Converter Check (IC3 and IC4)

IC3 and IC4 have four inputs each obtained from the decade counters, either IC6 or IC7. The inputs, designated by the letters, DCBA, are either high (1) or low (0) states. DCBA represents an 8, 4, 2, 1 binary coded digit. Refer to the lesson material for a further explanation of binary numbers. There are ten usable combinations of inputs to either IC3 or IC4. These are: 0000 (0), 0001 (1), 0010 (2), 0011 (3), 0100 (4), 0101 (5), 0110 (6), 0111 (7), 1000 (8), and 1001 (9), (binary number, decimal equivalent.) The next binary number after 1001 is 1010 which, because of the design of the decade counter, is never applied to the BCD converter. When all inputs are low (0), zero is indicated on the corresponding Nixie tube. When inputs D, C and B are low and A is high, one is indicated. If any of the above combinations of high or low states are applied to the four inputs, the digit displayed will be the decimal equivalent of the binary input.

To check IC3 and IC4, +1.5 volts will be applied to each input simulating a high logic state.

- Step 1. Solder a red jumper wire to the plus terminal of a 1.5 volt battery. Solder a black jumper wire to the negative terminal of the battery. Connect the other end of the black wire to circuit board ground. The free end of the red jumper wire will be used as a test probe to simulate high logic levels.
- Step 2. Remove Jumper A located on the circuit board and turn meter on. Removing Jumper A disconnects the oscillator from the input of IC7. The count displayed on both Nixies should be zero.
- Step 3. Touch the red jumper wire from the plus terminal of the 1.5 volt battery to each of the pins indicated in the following chart. Record the number displayed on each Nixie tube in the space provided. The numbers on the far right hand column indicate the number that you should see displayed under each condition.

<u>1.5 Volts Applied to IC3 Pin:</u>	<u>Number Displayed</u>	<u>Should Read</u>
3	_____	1
6	_____	2
7	_____	4
4	_____	8
3 and 4	_____	9
6 and 7	_____	6

<u>IC4 Pin</u>	<u>Displayed</u>	<u>Should Read</u>
3	_____	1
6	_____	2
7	_____	4
4	_____	8
3 and 4	_____	9
6 and 7	_____	6

- Step 4. Turn off meter and replace Jumper A. Remove all battery connections.

Analysis

Applying 1.5 volts to the A, B, C, and D inputs of IC3 or IC4 will cause the corresponding decimal equivalent number to be displayed. If two of the inputs are at a high level, the number displayed will be the sum of each input. For instance, a high state applied to pins 3 and 4 of IC3 will display a 9. A high at input 4 results in an 8 to be displayed. A high at input 3 results in a 1 displayed. Adding these together results in 9. If you do not obtain proper indications for one of the IC's, interchange IC3 and IC4 to find out if the problem is with the IC socket or the IC. If the problem shifts with the IC, replace the IC. If the problem remains with the IC socket, check for possible opens or shorts on the foil. If your previous tests on the Nixie tubes checked out, suspect the IC sockets.

JK Flipflop Check (IC5)

Refer to Figure 2 in the figure section of this manual for the following discussion. IC5 consists of two JK flipflops (FF1 and FF2) which control neon lamps DS201 and DS202. Inputs J and K to both flipflops are connected to VCC (+5 volts dc). When a reset pulse is applied to C (clear) on both flipflops, \bar{Q} is high (2-2.5Vdc) and Q is low (0 Vdc). The Q outputs for FF1 and FF2 bias Q13 and Q14 respectively. When either flipflop has a high Q output, the corresponding transistor will have a positive voltage applied to its base, causing it to conduct. When the transistor conducts, collector current flows through the neon lamp, causing it to light.

To make the JK flipflop change states, a negative going pulse is applied to input CP. This occurs after the 9 count from decade counter IC6 (See Figures 2 and 3). For a 9 count, the voltage at pin 11 of IC6 is high. When the count goes to zero, the voltage at pin 11 of IC6 drops from a high to a low state developing a negative going pulse. The negative going pulse applied to CP of FF1 causes the Q output of FF1 to change from a low state to a high state. Transistor Q14 is forward biased and neon lamp DS202 turns on. DS202 is the "one" lamp. At this time, input CP of FF2 is at a high state. If IC6 counts to 10 again, another negative going pulse causes the Q output of FF1 to drop from a high to a low state. Transistor Q14 and DS202 turn off. At the same time, input CP of FF2 goes from a high state to a low state, causing FF2 to change state. The Q output of FF2 is now high, providing the bias voltage to turn on transistor Q13, causing DS201 to turn on. DS201 indicates "overflow" in the readout. Note that 100 pulses must be counted for DS202 to turn on and 200 pulses are required to light DS201.

A reset pulse from IC8 allows both \bar{Q} outputs to resume a high level, forcing both Q outputs to a low level, thus resetting the flipflops. Reset pulses occur 60 times a second. It is necessary to remove IC8 when testing IC5 so that the output states of FF1 and FF2 can be controlled.

- Step 1. Solder a red wire to the positive terminal of a 1.5 volt D-cell battery. Solder a black wire to the negative terminal of the battery. Connect the black wire to meter common. (If your meter is not completely wired yet, connect the black lead to circuit board ground, circuit board hole M.) The red wire will be used as a test probe to simulate high logic states.
- Step 2. Turn off the meter, remove IC8 and turn the meter on to any function. The Nixie tubes should indicate zeros and the "over" lamp should be lit.
- Step 3. Touch the red wire to pin 9 of IC5. The "over" lamp should turn on if it isn't already lit.
- Step 4. Touch pin 12 of IC5 with the red wire. The "one" lamp will turn on. Remove the red wire and repeatedly touch pin 12. The neon lamps will alternately turn on and off.
- Step 5. Touch the red wire to IC5 pin 1. Remove the red wire and again touch IC5 pin 1 with the red wire. Do this several times and see what happens. Repeatedly touching the red wire to pin 1 of IC5 will change states of the "over" and "one" lamps.
- Step 6. Measure the dc voltages at the pins of IC5 and fill in the following chart.

<u>IC5 pin Number</u>	<u>DC Voltage Reading</u>
8	_____
9	_____
12	_____
13	_____

Chart Analysis

The voltage for the Q output of each flipflop will be either greater than 2 volts or zero. If the Q output is high, \bar{Q} is zero, or vice versa. If both the Q and \bar{Q} outputs of a flipflop are at zero or the same positive voltage, replace IC5.

Analysis

Steps 3 and 4 in the above procedure test transistors Q13 and Q14. The high state is simulated when 1.5 volts is applied to the Q outputs of IC5 at pins 9 and 12. The corresponding transistor is forward biased and the neon lamp in the collector circuit should light. If you do not obtain the proper results for steps 3 or 4, check the transistors for opens or shorts. Also check for poor solder connections, a defective neon lamp or open in the foil on the circuit board.

Step 5 tests each flipflop within IC5. If improper results are obtained for Step 5, check for poor solder connections or opens in the foil around IC5. Measure the dc source voltage at pins 3, 4, 7, 10 and 14 of IC5. You should measure about 5 volts at each pin. Refer to Section G of this guide if 5 volts is not measured.

Decade Counter Check (IC6 and IC7)

A 36 kHz input signal is applied to pin 14 of IC7 from the oscillator. IC7 increments the count once for each input pulse applied. IC7 and IC6 count from 0-9. On the tenth input pulse to pin 14 of IC7, a carry pulse is applied to pin 14 of IC6. 100 pulses are required at pin 14 of IC7 for IC6 to count 10 pulses. When IC6 counts a tenth pulse, IC6 generates a carry pulse. This pulse is applied to the input of IC5 causing the "one" lamp to light. The readout would be "100". The position of the decimal point will depend on the setting of the range switch.

Removing Jumper A prevents IC7 from counting pulses generated in the oscillator. Applying a low amplitude signal (squarewave) to IC7 pin 14 will simulate the oscillator's function. The display on the Nixie tubes depends on the frequency of the applied signal.

Test 1

- Step 1. Remove IC7. Set up on your design console the circuit shown in Figure 4.
Note: If your meter is not completely wired, meter common is circuit board common. (Black wire at hole M)
- Step 2. Locate pin 11 of the IC7 socket. A signal will be injected at this pin which is electrically connected to pin 14 of IC6.
- Step 3. Turn on the meter. The "tens" Nixie tube should display a zero. Ignore the digit displayed on the "units" Nixie tube.
- Step 4. Turn the frequency adjust control on the design console fully counterclockwise. Turn on the design console. Apply a squarewave signal from the test circuit of Figure 4 to pin 11 of the IC7 socket. The "tens" Nixie should display a count which will have several digits lit dimly, but one digit should be brighter than the rest.

- Step 5. Vary the frequency adjust potentiometer on the design console. Note that the brightest digit displayed will vary.
- Step 6. Turn the meter and design console off.

Analysis

When an input signal is applied to IC6, a count on the "tens" Nixie was displayed. Varying the adjust frequency control caused the count on the Nixie tube to vary and light both neon lamps. This test indicates that IC6 is operational.

If you were unable to vary the count, the problem may be a poor solder connection; solder or foil short on the circuit board; an open within the IC socket or circuit; or IC6 is defective. Check IC6 by replacing it with the IC removed from the IC7 position. Repeat Steps 2-6. If results are satisfactory, IC6 is defective.

Test 2

IC7 is checked in the same manner as IC6. The count on both Nixie tubes will vary. However, the neon lamps will remain off.

- Step 1. Remove Jumper A and replace IC7. Double check the mounting of IC7 to insure that it is mounted correctly.
- Step 2. Two pin connectors are used on the circuit board for Jumper A. Connect the red wire shown in Figure 4 to the connector closest to IC2.
- Step 3. Turn the meter and design console on.
- Step 4. Vary the adjust frequency control on the design console. Note the count on the Nixie tubes. Turn off the meter and replace all jumpers.

Analysis

Varying the frequency adjust control should vary the count on both Nixie tubes. Inability to obtain a variation may be caused by a solder short, open in the foil, poor solder connection or defective IC socket. If the integrated circuit is suspected, interchange IC6 and IC7. Repeat Test 1, Steps 2-6.

Pulse Shaping Check (IC8)

IC8 is a quadruple two input positive NAND Gate. IC8 shapes the timing pulses that are necessary to activate the ramp generator and reset IC6, IC7, IC5 and IC2. The input to IC8 is a half wave rectified ac voltage from the cathode of D16. This voltage, approximately

110 volts dc, must be dropped across R218 and R219, providing a 100 to 1 voltage divider, before the pulsating dc voltage is applied to pin 5 of IC8. Pin 4, the second input to NAND Gate C, is connected to the +5 volt source to maintain a high state input. Whenever the voltage at pin 5 goes high, the output of Gate C, pin 6, drops to a low state. The low state at pin 6 is applied to pin 9 of IC8. A low input at pin 9 of NAND Gate D causes the output at pin 8 to go high. Refer to Figure 5 of this troubleshooting guide for waveforms of IC8. These will be referred to during the following discussion.

The high output from pin 8 is applied to IC2, pins 2 and 8, and the base of Q5. The output is also applied to the differentiating network of C206 and R217. The voltage across R217 has the appearance of waveform X. Waveform X is superimposed on a dc reference voltage. The negative going pulses of waveform X provide the low input state for Gate A. The output would then be a positive pulse, waveform Y. This pulse is applied to IC6 and IC7, pins 2 and 3, for reset. This reset pulse is also the input to Gate B of IC8, resulting in a negative going pulse at pin 11, waveform Z. This pulse resets the JK flipflops of IC5. IC5, IC6 and IC7 are reset sixty times a second, at the trailing edge of the half wave rectified pulse present at pin 5 of IC8. Refer to waveforms U, Y and Z.

To check each gate within IC8, the output of each gate must be monitored while the input level of that gate is changed. This will be accomplished by shorting various pins of IC8 to ground. High or low logic levels will be indicated by high or low voltage readings.

Test 1

Step 1. Turn the meter on.

Step 2. Measure and record the voltages at pins 1 through 14 of IC8.

IC8 Voltages

Pin	Measured	Typical	Pin	Measured	Typical	Pin	Measured	Typical
1	_____	1.5	6	_____	1.8	11	_____	3.3
2	_____	4.8	7	_____	0 to 1	12	_____	0 to 1
3	_____	0 to 1	8	_____	1.3	13	_____	4.8
4	_____	4.8	9	_____	1.8	14	_____	4.8
5	_____	1.3	10	_____	4.8			

Step 3. Short pin 1 of IC8 to ground.

Step 4. Measure and record the voltages at pins 3, 11 and 12 of IC8.

Pin 3 _____ Vdc

Pin 11 _____ Vdc

Pin 12 _____ Vdc

Analysis

Referring to Figure 5, a negative going signal at pin 1 of IC8 produces a positive pulse at pin 3. Shorting pin 1 of IC8 simulates the negative going pulse. The voltage at pin 3 and pin 12 should have increased from .1 volt to over 2.5 volts. If so, Gate A is operating properly. Your reading for pin 11 should decrease to under 1 volt. If so, Gate B is operating properly. If improper results were obtained for either Gate A or B, check for poor solder connections and, if necessary, replace IC8.

Test 2

Step 1. Short pin 5 of IC8 to ground.

Step 2. Measure and record the voltages at pins 6, 8 and 9 of IC8.

Pin 6 _____ Vdc Pin 8 _____ Vdc Pin 9 _____ Vdc

Analysis

Shorting pin 5 of IC8 simulates a low input level to Gate C. As a result, the voltage at pin 6 should increase to over 3 volts. If so, Gate C is operating properly. The high logic level voltage at pin 6 should also be read at pin 9. Pin 9 is the input to Gate D. The voltage at pin 8 should drop to almost zero. If so, Gate D is operating properly. If any part of IC8 is found to be defective, order a replacement from Heath.

Oscillator Check (Q12, Q15 and Q16)

The oscillator circuitry in the digital multimeter produces the pulses necessary for the counting circuits to produce the visible read out on the Nixie tubes. The oscillator is a free running multivibrator employing transistors Q16 and Q15. Frequency adjustment is provided by resistor R207 which varies the discharge time for capacitor C201. The oscillator is turned on and off by transistor Q12. When Q12 is conducting, the base of Q16 is shorted to ground and Q16 is cut off. Consequently, the oscillator is disabled. When Q12 is cut off, Q16 base is no longer shorted to ground and normal multivibrator action takes place. The length of time that Q12 is turned off is directly proportional to the amplitude of the dc voltage applied to the A/D converter. Therefore, the number of pulses out of the oscillator for any given operational time period is also directly proportional to the dc input voltage to the A/D converter. Thus, an analog input voltage to the A/D converter results in a pulse train out, with the number of pulses directly proportional to the amplitude of the analog input voltage.

The check out of the oscillator is relatively easy. Since the oscillator is designed to free run when transistor Q12 is cut off, it is only necessary to isolate the oscillator from the remainder of the circuit, remove forward bias from transistor Q12 and then measure the ac output voltage of the oscillator.

Test 1

- Step 1. Turn off the meter. Remove integrated circuit IC2 from its socket. Remove jumpers A, B and C from the circuit board.
- Step 2. Turn on the meter. Using the small multimeter (VOM) which was included in your first laboratory shipment, measure the ac voltage at the collector of transistor Q15. A reading of approximately 3 volts ac should be measured.
- Step 3. Connect one end of a 12 inch jumper wire to circuit board ground. While monitoring the ac voltage at the collector of transistor Q15 as in Step 1 above, touch the free end of the jumper wire to the collector of transistor Q12. The ac voltage reading at the collector of Q15 should drop to zero.
- Step 4. Turn off the meter. Replace integrated circuit IC2 and jumpers A, B and C on the circuit board.

Analysis

Steps 1 and 2 isolate the oscillator from the remainder of the circuitry and allow you to measure the oscillator output voltage. In Step 3, you disabled the oscillator to make sure that your ac voltage reading was actually the output of the oscillator, not some stray voltage due to circuit problems. Failure to obtain the proper readings in Steps 2 or 3 indicates a problem with the oscillator. To isolate the problem, voltage readings may be made on the elements of the transistors and compared with the schematic. The best method however, is to simply remove transistors Q12, Q15 and Q16 and check them using a standard transistor resistance check. Other components can be checked for shorts or opens using resistance checks. Be sure to check diode D17 for proper position on the circuit board and to insure that it is in good condition.

NOTE: Due to circuit tolerances, you may find that your oscillator frequency cannot be adjusted to the "over 0.85" called for in the manual. If this occurs, the value of R208 may be varied between 5 and 15K ohms in order to bring the oscillator to the proper frequency. Increasing the value of R208 will decrease the oscillator frequency. Decreasing the value of R208 will increase the oscillator frequency.

Oscillator Switch Check (IC2)

IC2 is a quadruple two input positive NOR gate. These gates are used as a switch to turn on and off the oscillator. Refer to the block diagram of IC2 shown in Figure 6 of this troubleshooting guide for the following circuit description.

A positive voltage from the ramp generator is applied to pin 12 of IC2, causing the output (pin 13) of gate D to drop to a low state. This occurs when the control voltage from IC8 applied to pin 8 is also at a low state. The low state at pin 13 performs three functions:

removes the forward bias voltage on D17 and Q12 which allows the oscillator to free run; drops the bias at the base of Q3 to cut off Q3, Q2 and Q6; and switches Gate B output from a low to a high level to clamp the input of Gate D at a high level when the positive voltage at pin 12 is no longer present.

Prior to the positive voltage at pin 12, at time $T1 = T2$ (see figure 2-5 page 2-43 of construction manual 9550-2 part 1) the inputs to Gate B are low at pin 8 and high at pin 9. The output of Gate B would be a low state according to the Truth Table for NOR gates.

Truth Table
for NOR Gates

<u>A</u>	<u>B</u>	<u>Output</u>
0	0	1
1	0	0
0	1	0
1	1	0

Both inputs to Gate D would be low states, yielding a high state at pin 13. This high state provides bias for D17 and Q12. Q12 saturates and shorts the oscillator. A high state at pin 13 also provides bias to the base-collector junction of Q3.

When Q2 and Q6 conduct, a positive voltage is applied to pin 12 of IC2. With a high input voltage, Gate D changes output states from a high to a low level. The low level is felt at pin 9, an input to gate B. Gate B then changes output states from a low to high level. With the high level at pin 11 held constant by Gate B, the output of Gate D will remain at a low level even though the voltage at pin 12 is no longer present as explained in the section on the ramp generator. This clamping action also takes place with Gates A and C through the feedback loop from pin 1 to pin 5 with the occurrence of a stop pulse.

Two tests are provided to check the operation of IC2. The first test checks the operation of the individual NOR gates within the IC. The second test will check the operation of the IC in conjunction with the other components in the oscillator switch circuitry.

Test 1

- Step 1. Remove jumpers A, B, C, D, E and F.
- Step 2. Turn on the meter to any function and any range. Disregard the display.
- Step 3. Using the small multimeter (VOM) you received in your first lab shipment, measure the dc voltages at pins 1, 4, 10 and 13 of IC2. You should measure less than 1 volt dc at each pin.

- Step 4. Connect one end of a 12 inch jumper wire to circuit board common (circuit board hole M or meter common, C, jack). Place the other end of the jumper wire between pins 2 and 3 of IC2. Hold the wire at a slight angle so that contact is made to both pins at the same time. While the wire is in place, measure the dc voltage at pin 1 of IC2. You should measure greater than 2.5 volts dc at this point.
- Step 5. Remove the jumper wire from between pins 2 and 3 of IC2. Place the jumper wire between pins 5 and 6 of IC2, again being sure that the wire touches both pins. Measure the dc voltage at pin 4 of IC2. You should measure greater than 2.5 volts dc at this point.
- Step 6. Remove the jumper wire from between pins 5 and 6 and place the jumper wire between pins 8 and 9 of IC2. Once again, make sure the jumper wire touches both pins. Measure the dc voltage at pin 10 of IC2. You should measure at least 2.5 volts dc at this point.
- Step 7. Remove the jumper wire from between pins 8 and 9. Place the jumper wire between pins 11 and 12 of IC2, making sure that the wire touches both pins. Measure the dc voltage at pin 13 of IC2. You should read at least 2.5 volts dc at this point.
- Step 8. Turn off the meter. Replace all jumper wires.

Analysis

By removing the jumper wires in Step 1, we isolate IC2 from the remainder of the circuitry. Because of internal circuitry in the IC, removing the jumper wires insures that at least one input of each NOR gate within the IC is at a high state. As shown in the truth table for NOR gates, if one input of a NOR gate is high, the output is low. We check for the low state output in Step 3. If you do not get the proper readings in Step 3, the IC is defective and should be replaced.

Again referring to the Truth Table for NOR gates, we see that if both inputs are zero or a low state, the output is high. In Steps 4, 5, 6 and 7, we hold both inputs of each NOR gate at a low state and check that the output of each particular gate is high under these conditions. Failure to obtain the proper voltage readings in Steps 4, 5, 6 or 7 indicates a defective IC and it should be replaced.

Test 2

- Step 1. Plug in the meter and turn the meter on.
- Step 2. Short the base of Q12 to circuit board ground (black wire at hole M). All lights on each Nixie tube and both neon lamps should light.

- Step 3. Short the anode of D17 to ground. All lights on each Nixie tube and both neon lamps should light.
- Step 4. Short pin 1 of IC2 to ground. The "over" light and a digit should be displayed in each Nixie tube. This count is variable by adjusting the oscillator adjust potentiometer (try it).
- Step 5. Short pin 13 to ground. All numbers on each Nixie tube and both neon lamps should light.
- Step 6. Turn the DMM off. Remove jumper B. Turn the DMM on. All numbers on the Nixie tubes will be lit.
- Step 7. Short pin 10 of IC2 to ground. A zero count should be displayed.
- Step 8. Short pin 13 of IC2 to ground. All numbers in both neon lamps should light.
- Step 9. Short pin 10 of IC2 to ground to reset the IC.
- Step 10. Short pin 1 of IC2 to ground. All numbers on both Nixie tubes should light.
- Step 11. Short pin 10 of IC2 to ground. A zero count should be displayed.

Analysis

Shorting the base of Q12, anode of D17 or pin 13 of IC2 to ground removes the forward bias from Q12. This makes Q12 appear to be an open to the oscillator which allows the oscillator to free run. As a result, all lights will be lit because the oscillator is running during read out time. Shorting pin 1 of IC2 prevents the output of Gate A from biasing D17 and Q12 when a stop pulse is applied to Gate C. If improper results are obtained for steps 1 through 5, check soldering, component location and installation of R210, R204, D17 and Q12. With jumper B removed, reset pulses from IC8 are no longer applied to pins 2 or 8 of IC2. This enables us to control the logic states of IC2. Shorting pins 1, 5, 9 and 13 to ground will cause all numbers of both Nixie tubes to light. Shorting pins 10 or 11 to ground will drop the count to zero. When the jumper wire used for shorting the pins to ground was removed from a pin on IC2, the test conditions of either all numbers or all zero's displayed would remain.

Ramp Generator Check (Q1 through Q7)

Figure 7 is a block diagram of the ramp generator. The control signal from IC8, pin 8 is applied to the base of Q5. If a positive voltage is applied to the Q5 base, Q5 saturates, dropping the collector voltage to near zero. When Q5 conducts, the charge across C106 will discharge through Q5 and its collector load resistor. When Q5 is cut off, C106 charges through the dc calibration potentiometer and Q7 (constant current source) towards +15 volts dc.

To analyze the ramp generator, we must assume a time reference. Refer to the waveforms in manual 9550-2, part 1, page 2-43, figure 5. At time $T_1 = T_2$, the control voltage from IC8, pin 5, drops from a high to a low level (waveform B). Also, the voltage at jumper D and pin 13 of IC2 are at a high level saturating Q3. Q5 is cut off and C106 starts charging through Q7 at a linear rate (waveform C). When C106 starts charging, the base of Q2 becomes forward biased and Q2 turns on. Q2 collector current turns on Q6 and Q6 collector current flows from ground through the zero adjust potentiometer. A positive voltage is felt at the collector of Q6 with respect to ground. This positive voltage is applied to IC2, pin 12. Gate D changes output states from a high to a low level. The low level now at pin 13 and jumper D removes the bias on Q3, thus turning Q3 off. Q3 acts as an open to Q2 current flow. Without a complete current path, Q2 and Q6 no longer conduct. The positive voltage at the collector of Q6 is no longer present. This insures only a short positive pulse will appear at the input of Gate D, IC2.

As capacitor C106 charges during time T3 the oscillator is free running. Eventually capacitor C106 will obtain a charge .6 volts greater than the emitter voltage of Q1. Q1 emitter voltage is determined by the dc voltage at the input of the A/D converter. When this occurs, Q1 will conduct. Q1 collector current forward biases Q4. Q4 collector current will now flow from ground through the zero adjust potentiometer. This positive voltage at the collector of Q4 is applied to pin 6 of Gate C, IC2. Pin 1 of IC2 goes from a low to a high level, causing D17 and Q12 to conduct, shorting the oscillator. At the same time, the high level at pin 1 of IC2 is fed through R201 to the base of Q5. Q5 saturates to discharge C106. When the voltage across C106 drops, the base-emitter voltage of Q1 decreases. Q1 is no longer forward biased and Q4 is turned off. The positive voltage at the collector of Q4 is also only a short positive pulse.

Start and stop pulses will occur only when the control pulse from IC8 is at a low level. If a stop pulse does not occur before the control signal from IC8 goes positive, "over 85" will be read on the display tubes.

To test the ramp generator, jumpers C, D, E and F are removed to isolate the ramp generator from the rest of the circuit. A 1.5 volt battery will be used to saturate Q5 to simulate a high logic level normally provided by IC8. A direct comparison between the voltages at the elements of Q1 through Q7 with Q5 saturated to the voltages of Q1 through Q7 with Q5 cut off will help isolate any defective parts.

All measurements for the following charts were measured using a 20,000 ohm per volt multi-meter. These dc voltage readings will be slightly higher if a meter with a higher input impedance is used.

Test 1

Step 1. Remove jumper wires C, D, E and F. Turn on the meter to any range or function. Center the zero adjust control. Measure and record the voltages for each element of Q1 through Q7 and fill in chart A.

Chart A
Ramp Generator Voltage Measurements*

	Base		Emitter		Collector	
	<u>Measured</u>	<u>Typical</u>	<u>Measured</u>	<u>Typical</u>	<u>Measured</u>	<u>Typical</u>
Q1 _____		8.8	_____	8.6	_____	8.4
Q2 _____		8.2	_____	8.2	_____	8.2
Q3 _____		.6	_____	8.2	_____	-0-
Q4 _____		8.4	_____	15.0	_____	.6
Q5 _____		-0-	_____	-0-	_____	8.8
Q6 _____		8.2	_____	15.0	_____	2.5
	Gate		Source		Drain	
Q7 _____		8.8	_____	11.0	_____	15.0

*Jumper wires C, D, E and F are removed.

Step 2. Solder a red jumper wire to the positive terminal of a 1.5 volt battery. Solder a black jumper wire to the negative terminal of the battery. Connect the other end of the black wire to circuit board ground. The free end of the red jumper wire will be used as a test probe to simulate high logic levels.

Step 3. Two wire connectors are used for jumper C. Insert the free end of the red jumper wire from the plus terminal of the 1.5 battery into the connector closest to the zero adjust potentiometer.

Step 4. Measure and record the voltages for chart B.

Chart B
Ramp Generator Voltage Measurements**

	Base		Emitter		Collector	
	<u>Measured</u>	<u>Typical</u>	<u>Measured</u>	<u>Typical</u>	<u>Measured</u>	<u>Typical</u>
Q1 _____		.3	_____	-0-	_____	5.5
Q2 _____		.3	_____	-0-	_____	4.0

**Readings are taken with Q5 saturated.

Chart B (cont.)

	Base		Emitter		Collector	
	<u>Measured</u>	<u>Typical</u>	<u>Measured</u>	<u>Typical</u>	<u>Measured</u>	<u>Typical</u>
Q3	_____	-0-	_____	-0-	_____	-0-
Q4	_____	5.5	_____	15.0	_____	-0-
Q5	_____	1.3	_____	-0-	_____	.3
Q6	_____	4.0	_____	15.0	_____	-0-
		Gate		Source		Drain
Q7	_____	.3	_____	2.2	_____	15.0

Analysis

Voltages shown in both charts are typical values. Your readings should compare favorably to those shown.

When 1.5 volts is applied to the base of Q5, Q5 saturates. When Q5 saturates, the collector of Q5 appears to be at ground potential. Capacitor C106 will discharge through Q5, thus lowering the base voltage of Q1. The collector of Q5 should drop from 9 to .3 volts. This sudden drop should also be noticed at the bases of Q1, Q2 and the gate of Q7. The source of Q7 will drop from 11 to 2.2 volts.

Decreasing the base voltage of Q2 also will reflect a decrease in emitter voltage for Q2, Q3 and the base voltage of Q3. With .3 volts at the base of Q2, Q2 has insufficient voltage to remain forward biased. Without proper bias for Q2, Q2 is cut off.

When measuring the collector voltage of Q1 and Q2, the internal resistance of the small multimeter (VOM) will complete the base current path for transistors Q4 and Q6, respectively. The base current flowing through the internal resistance of the VOM will cause the needle to deflect. When Q5 is turned off, Q1 and Q2 will normally be conducting resulting in a collector voltage of 8 to 8.5 volts to be measured. When Q5 is saturated, Q1 and Q2 will normally be in cut off states, therefore the collector voltages (or base voltages of Q4 and Q6, respectively) should read 15 volts, the same as the emitter of Q4 and Q6, respectively. Due to the VOM's internal resistance completing the base current path to ground for Q4 and Q6, the voltage at the bases of Q4 and Q6 will be low, around 4 to 5 volts.

A direct comparison of the voltages for both Chart A and Chart B of this section should reveal any defective transistors. If the voltage measurements for any transistor do not change as indicated, suspect that transistor as being defective. Remove the transistor and use a standard resistance check to check the transistor.

Section G Power Supply Troubleshooting

The power supply of the digital multimeter provides the dc operating voltages for the meter. Section G includes a circuit analysis and troubleshooting guide.

Refer to the schematic diagram for the following circuit description. The power supply provides four dc voltages for operation of the meter. These are the 110 volt dc supply voltage for the Nixie tubes and neon lamps, the plus and minus 15 volt dc voltages for driving the ac converter and ramp generator and the +5 dc supply for driving the oscillator and integrated circuits IC2-IC8.

Three secondaries provide 15 volt ac, 35 volt ac and 250 volt ac. The 15 volt secondary is center tapped and applied to a full wave rectifier consisting of D11 and D12. The 7.5 volt dc output of this full wave rectifier is filtered by capacitor C114 and applied to the collector of Q11. Q11, a Darlington Amplifier, provides series regulation of the +5 volt source. A reference voltage is applied to the base of Q11 from zener diode D10. Note that zener diode D10 also provides the dc calibration voltage for the meter through resistors R148 and R149. In order to insure proper calibration of your meter, if any of these three components are defective, D10, R148 or R149, all three must be replaced with a calibration package. Consult your construction manual for the proper part number for a complete dc calibration package for your meter. The dc supply for the zener diode is developed from the +15 volt source.

The plus and minus 15 volt supplies are developed from the 35 volt secondary. Notice that neither side of this secondary is tied to ground. Half wave rectifier D13 provides a dc voltage filtered by capacitor C117 which is applied to diodes D14 and D15. The junction of these two diodes is tied to ground. The diodes, both 15 volt zener diodes, provide the regulated 15 volt plus and minus supplies.

The 250 volt secondary is applied to half wave rectifier D16. Notice that there is no filtering on this supply. The half wave output from this power supply is used in the circuit to insure the Nixie tubes and neon lamps are only on during readout time. In addition, this half wave rectified voltage is applied to IC8 to provide a sampling time base. Also, the half wave is dropped across a voltage divider consisting of R161, R162 and R163 to provide ac calibration voltage.

The troubleshooting procedure is straightforward. Complete the following tests and for any test whose results are not satisfactory, follow the instructions in the analysis.

Test 1

Step 1. Turn on the digital multimeter and set the function switch to any position other than the off position. The range switch may be left at any position. Using the multimeter (VOM) you received in your first lab shipment, measure the ac voltage across terminals 1 and 4 of transformer T1. A reading of 110 to 120 volts ac should be measured.

Step 2. Using the VOM, measure the ac voltage between circuit board holes T and U, W and V, and R and S. Record your voltage readings in the chart below.

AC Voltage Checks

<u>Test Points</u>	<u>Measured Value</u>	<u>Typical Value</u>
Hole V to Hole W	_____	35 Vac*
Hole T to Hole U	_____	15 Vac*
Hole R to Hole S	_____	250 Vac*

Step 3. Using your VOM, measure the dc voltage at the points listed in the chart below. Record your readings in the space provided.

DC Voltage Checks

<u>Test Points</u>	<u>Measured Value</u>	<u>Typical Value</u>
Collector, Q11	_____	+7.5 Vdc**
Base, Q11	_____	+6.2 Vdc***
Emitter, Q11	_____	+5 Vdc***
Cathode, D13	_____	+25 Vdc*
Cathode, D14	_____	+15 Vdc**
Anode, D15	_____	-15 Vdc**
Cathode, D16	_____	+110 Vdc*

*±20%

**±10%

***±5%

Analysis

In step 1, the presence of proper ac voltage at the primary of T1 is checked. Failure to get the proper ac voltage may indicate a defective fuse or on/off switch. In addition, the power cord may be defective or there may be a soldering or wiring error. Resistance checks can reveal opens in the circuit and these can be corrected. If any defective components are found, order replacements from the Heath Company. Note: If F2 continually blows there is a short circuit either in the primary or secondary circuits of T1. Additional troubleshooting will be necessary. Usually, this involves removing all secondary connections from the transformer. A new fuse is then inserted and the meter is turned on. If the fuse blows again, a short circuit exists either in the transformer or in the primary wiring. If the fuse holds, the secondaries should be reconnected one by one, turning the meter on after each secondary is connected. You will find the meter will begin to blow fuses when the secondary which contains the short circuit is connected. Troubleshooting in the circuitry associated with this secondary should reveal the source of the short.

Steps 2 and 3 check the secondary ac and dc voltages. Failure to measure the proper ac voltages in Step 2 could be an indication of a defective transformer or excessive loading on the secondary. To check for loading, remove the wires from the transformer and measure directly across the wires with no load. If proper voltages cannot be obtained, replace the transformer. If the proper voltages are obtained with the wires removed from the circuit board, troubleshoot the rectifier and regulator circuits. If proper results are obtained in Step 2 but not Step 3, there is a problem in that area in which satisfactory voltage readings were not obtained. Individual components can be checked using resistance checks. Keep in mind that no resistance check is valid in-circuit. Remove at least one end of any component from the circuit board before making resistance checks. Doublecheck to insure that proper polarity is observed on semiconductors and electrolytic capacitors.

Low dc voltage readings, especially in the +5 volt supply, can be due to loading effects of a short circuit in the meter circuitry itself. If your problem concerns a low +5 volt reading and no problem can be found within the power supply itself, shut off the meter and remove all integrated circuits. Replace the integrated circuits one by one, being sure to shut the meter off each time you remove or replace an integrated circuit, and measure the 5 volt supply after each integrated circuit is replaced. You may find one or more integrated circuits, which, when replaced in the meter, will load down the 5 volt supply giving the erroneous reading. This integrated circuit(s) must then be replaced.

APPENDIX A

FIGURE SECTION

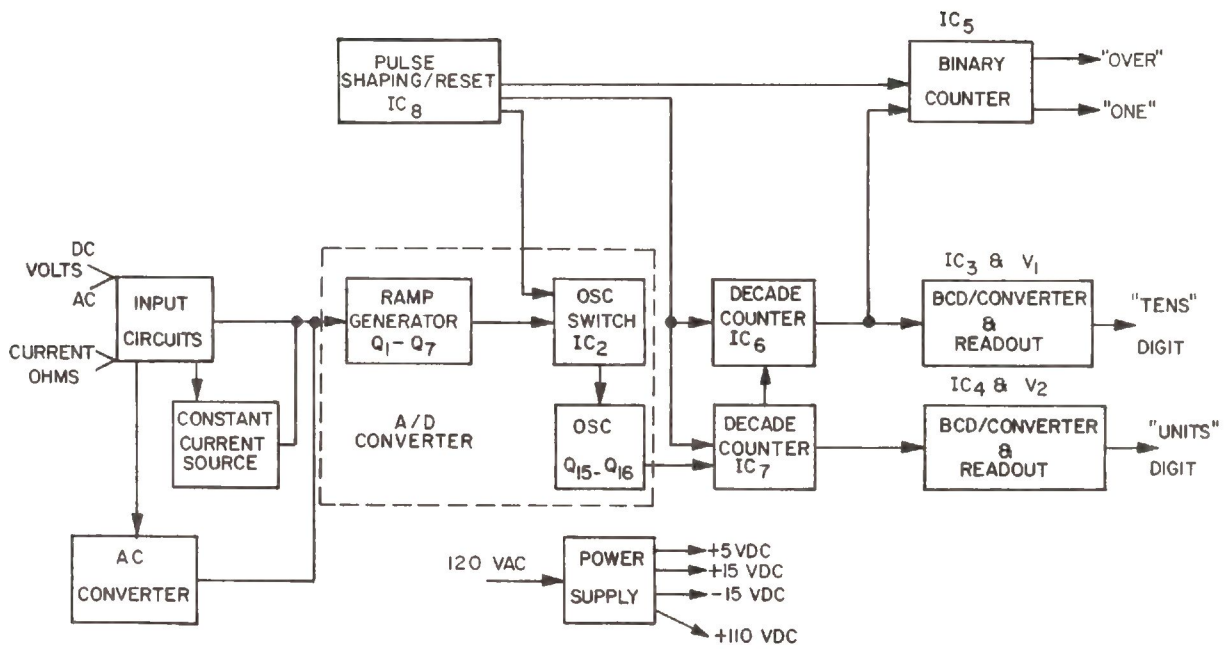

DMM BLOCK DIAGRAM
FIGURE 1

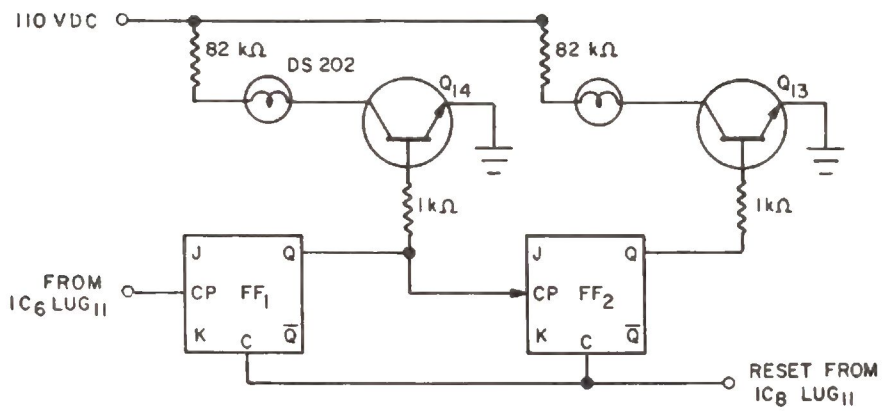

FIGURE 2

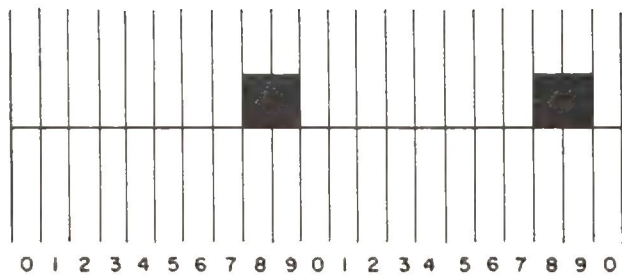

FIGURE 3

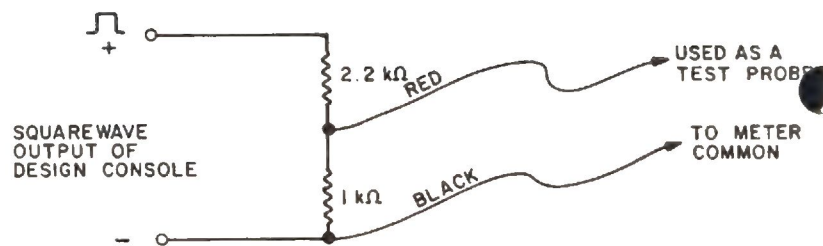

FIGURE 4

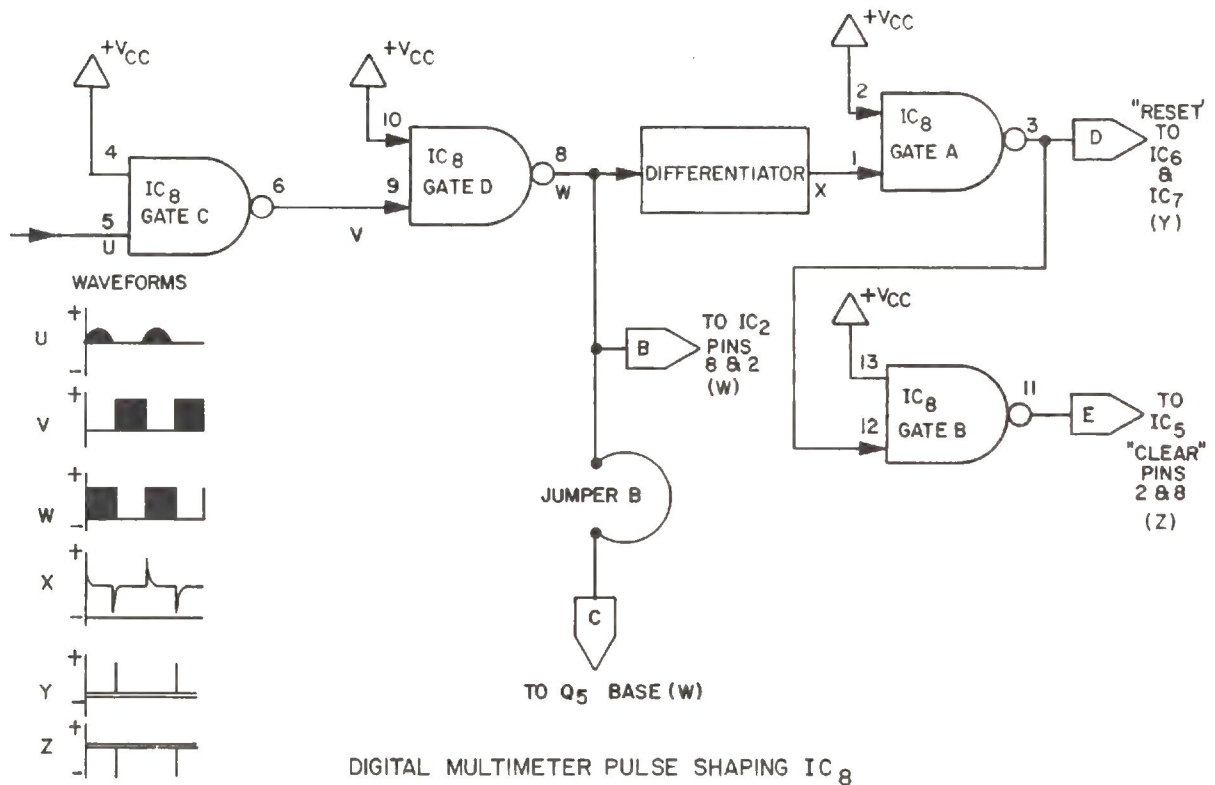

FIGURE 5

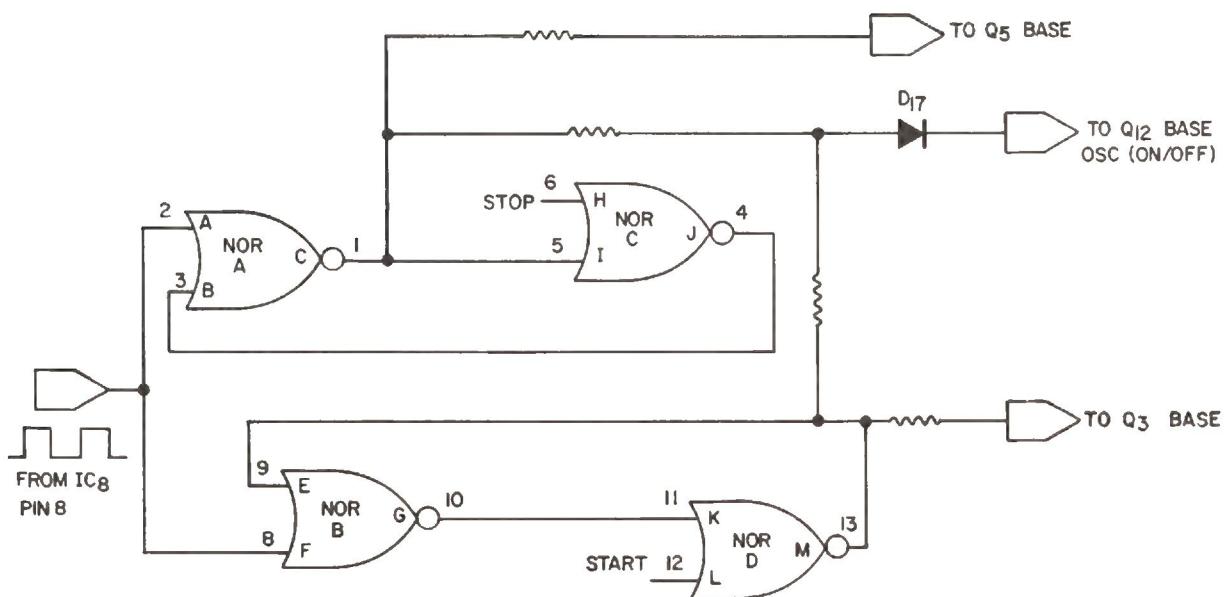

FIGURE 6

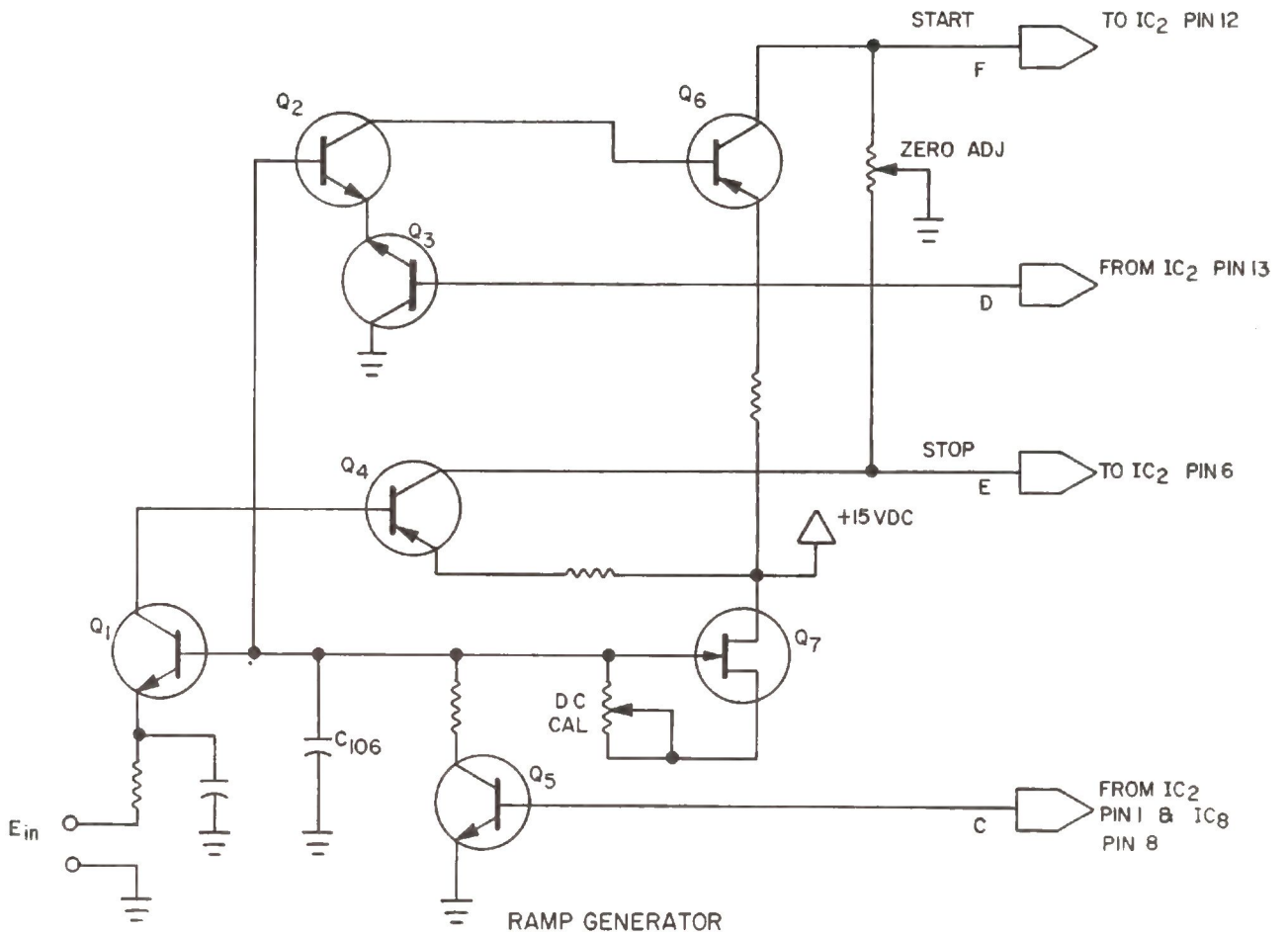
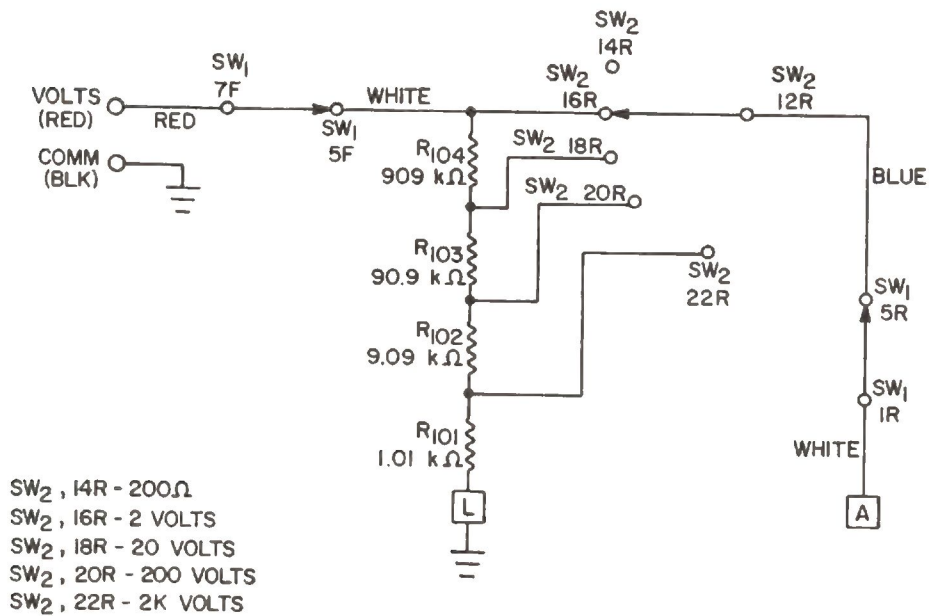

FIGURE 7



- SW₂, 14R - 200Ω
- SW₂, 16R - 2 VOLTS
- SW₂, 18R - 20 VOLTS
- SW₂, 20R - 200 VOLTS
- SW₂, 22R - 2K VOLTS

A BOXED LETTERS INDICATE CIRCUIT BOARD HOLES

D.C. VOLTS

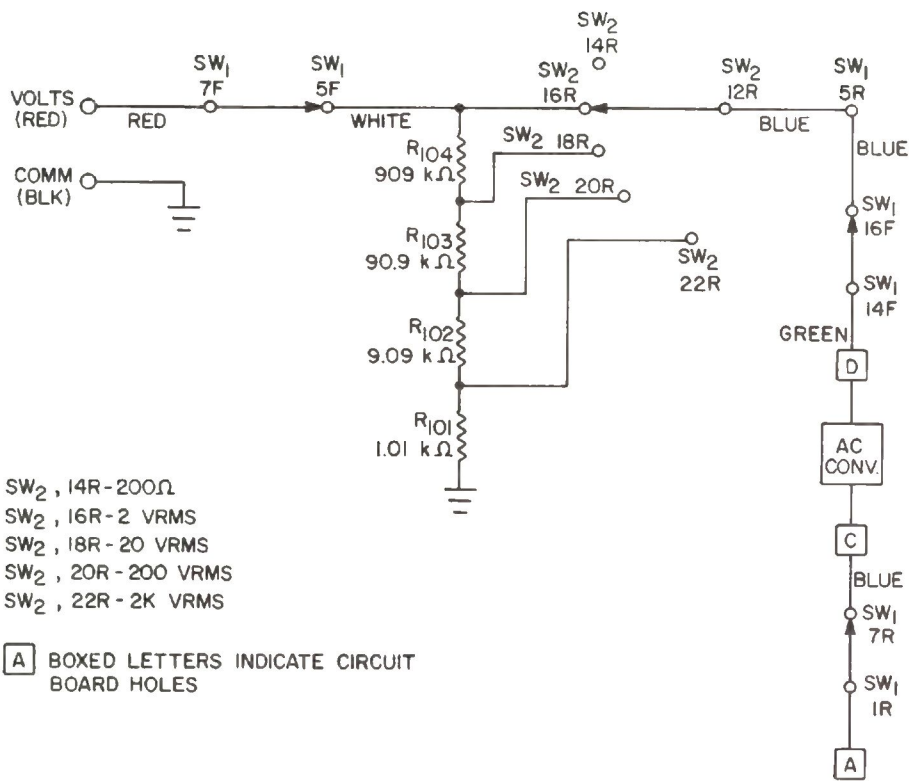

A.C. VOLTS

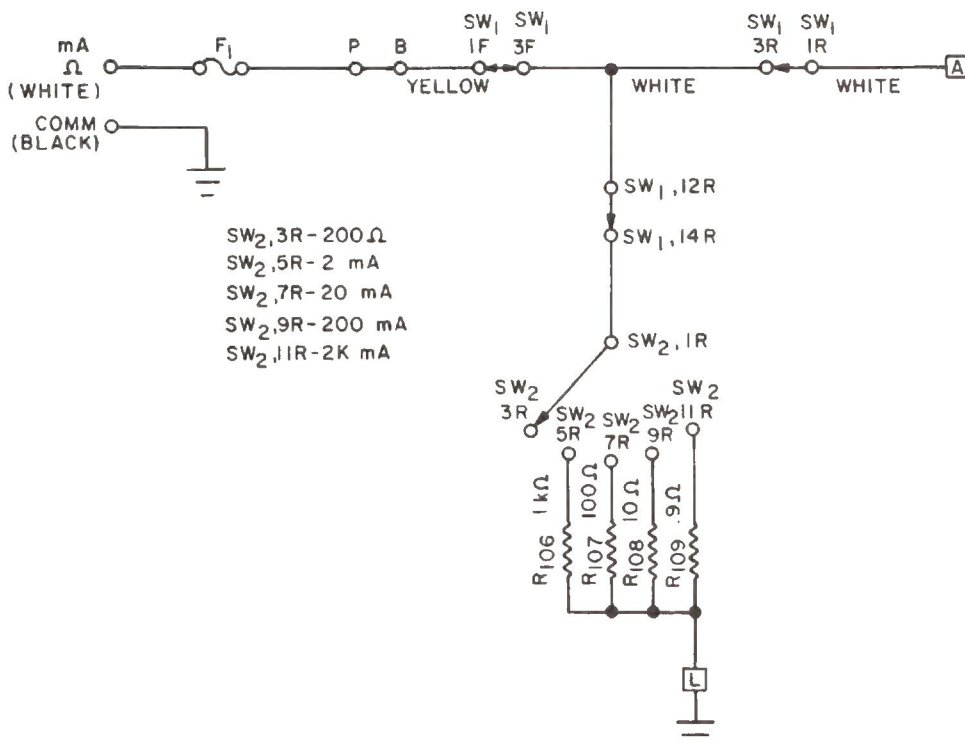

DC mA

APPENDIX B

BELL & HOWELL SCHOOLS DIGITAL MULTIMETER WIRING CHECK LIST

NOTE: The lugs of SW1 and SW2 are numbered in a clockwise direction as viewed from the front. Each possible location is numbered even though every hole does not have a lug. There are two wafers on each switch and are designated as F (front) and R (rear) as viewed from the front of the switch. With the switches properly mounted on the meter, when viewed from the front of the meter, lug number 1 is the extreme left hand lug just above the spacer which separates the switch decks.

SW1 -- FUNCTION SWITCH (front deck)

- 1F -- One connection: yellow wire to Hole B
- 2F -- Not used
- 3F -- Two connections: white wire to 20F (SW1); white wire to 3R (SW1)
- 4F -- Not used
- 5F -- One connection: white wire to 16R (SW2)
- 6F -- Not used
- 7F -- One connection: red wire to red input jack (V)
- 8F -- Not used
- 9F -- Not used
- 10F -- Not used
- 11F -- Not used
- 12F -- Not used
- 13F -- Not used
- 14F -- One connection: green wire to Hole D
- 15F -- Not used
- 16F -- One connection: blue wire to 5R (SW1)

17F -- Not used

18F -- One connection: bare wire to 20F (SW1)

19F -- Not used

20F -- Two connections: bare wire to 18F (SW1); white wire to 3F (SW1)

21F -- Not used

22F -- Not used

SW1 -- FUNCTION SWITCH (Rear deck)

1R -- One connection: white wire to Hole A

2R -- Not used

3R -- Two connections: white wire to 3F (SW1); white wire to 11R (SW1)

4R -- Not used

5R -- Two connections: blue wire to 16F (SW1); blue wire to 12R (SW2)

6R -- Not used

7R -- One connection: bare wire to 9R (SW1)

8R -- Not used

9R -- Two connections: bare wire to 7R (SW1); blue wire to Hole C

10R -- Not used

11R -- Two connections: white wire to 3R (SW1); white wire to 12R (SW1)

12R -- One connection: white wire to 11R (SW1)

13R -- Not used

14R -- Two connections: yellow wire to 20R (SW1); yellow wire to 1R (SW2)

15R -- Not used

- 16R -- Not used
- 17R -- Not used
- 18R -- Not used
- 19R -- Not used
- 20R -- One connection: yellow wire to 14R (SW1)
- 21R -- Not used
- 22R -- One connection: brown wire to Hole F
- SW2 -- RANGE SWITCH (front deck)
 - 1F -- One connection: 27K ohm resistor to 4F (SW2)
 - 2F -- Two connections: white wire to 21F (SW2); bare wire to 4F (SW2)
 - 3F -- Two connections: red wire to 9F (SW2); red wire to Hole X
 - 4F -- Four connections: 27K ohm resistor to 1F (SW2); bare wire to 2F (SW2); bare wire to 6F (SW2); 1K ohm resistor to 5R (SW2)
 - 5F -- One connection: yellow wire to Hole Y
 - 6F -- Three connections: bare wire to 4F (SW2); 100 ohm resistor to 7R (SW2); bare wire to 8F (SW2)
 - 7F -- Not used
 - 8F -- Three connections: bare wire to 6F (SW2); bare wire to 10F (SW2); 10 ohm resistor to 9R (SW2)
 - 9F -- One connection: red wire to 3F (SW2)
 - 10F -- Three connections: bare wire to 8F (SW2); black wire to 13F (SW2); .9 ohm resistor to 11R (SW2)
 - 11F -- Not used
 - 12F -- One connection: white wire to Hole E

13F -- Three connections: black wire to 10F (SW2); black wire to Hole L; 1 megohm resistor to 14R (SW2)

14F -- One connection: red wire to Hole G

15F -- Not used

16F -- One connection: brown wire to Hole N

17F -- Not used

18F -- One connection: green wire to Hole K

19F -- Not used

20F -- One connection: blue wire to Hole J

21F -- Two connections: 1.01K ohm resistor to 22R (SW2); white wire to 2F (SW2)

22F -- One connection: yellow wire to Hole H

SW2 -- RANGE SWITCH (rear deck)

NOTE: The rear deck of the range switch, SW2, consists of two identical switches connected in parallel. This is to insure a low resistance path through the switch contacts. When checking the connections to these lugs, make sure all connections for the rear deck of the range switch are made to a pair of lugs, one on either side of the rear wafer. To be sure that the wires or resistor leads are connected properly to both lugs, refer to the assembly pictorials in Assembly Manual 9550-2, part 1.

1R -- One connection: yellow wire to 14R (SW1)

2R -- Not used

3R -- One connection: white wire to 14R (SW2)

4R -- Not used

5R -- One connection: 1K ohm resistor to 4F (SW2)

6R -- Not used

7R -- One connection: 100 ohm resistor to 6F (SW2)

- 8R -- Not used
- 9R -- One connection: 10 ohm resistor to 8F (SW2)
- 10R -- Not used
- 11R -- One connection: .9 ohm resistor to 10F (SW2)
- 12R -- One connection: blue wire to 5R (SW1)
- 13R -- Not used
- 14R -- Two connections: 1 megohm resistor to 13F (SW2); white wire to 3R (SW2)
- 15R -- Not used
- 16R -- Two connections: 909K ohm resistor to 18R (SW2); white wire to 5F (SW1)
- 17R -- Not used
- 18R -- Two connections: 909K ohm resistor to 16R (SW2); 90.9K ohm resistor to 20R (SW2)
- 19R -- Not used
- 20R -- Two connections: 90.9K ohm resistor to 18R (SW2); 9.09K ohm resistor to 22R (SW2)
- 21R -- Not used
- 22R -- Two connections: 9.09K ohm resistor to 20R (SW2); 1.01K ohm resistor to 21F (SW2)

PRINTED CIRCUIT BOARD HOLE WIRE CHECK LIST

HOLE

- A -- White wire to 1R (SW1)
- B -- Yellow wire to 1F (SW1)
- C -- Blue wire to 9R (SW1)
- D -- Green wire to 14F (SW1)

- E -- White wire to 12F (SW2)
- F -- Brown wire to 22R (SW1)
- G -- Red wire to 14F (SW2)
- H -- Yellow wire to 22F (SW2)
- I -- Not used
- J -- Blue wire to 20F (SW2)
- K -- Green wire to 18F (SW2)
- L -- Black wire to 13F (SW2)
- M -- Black wire to black input jack (C)
- N -- Brown wire to 16F (SW2)
- O -- Not used
- P -- Bare wire to lug 1, Fuse 1
- Q -- Not used
- R -- Red wire to power transformer
- S -- Black wire to power transformer
- T -- Blue wire to power transformer
- U -- Blue wire to power transformer
- V -- Yellow wire to power transformer
- W -- Yellow wire to power transformer
- X -- Red wire to 3F (SW2)
- Y -- Yellow wire to 5F (SW2)

INPUT JACKS

Red -- Red wire to 7F (SW1)

White -- White wire to lug 2, Fuse 1

Black -- Black wire to Hole M

ON/OFF SWITCH (mounted on rear of SW1)

NOTE: Lug numbering not critical

Lug 1 -- Red wire to lug 1, Fuse 2

Lug 2 -- Red wire to lug 1, power transformer

POWER TRANSFORMER (120 volt operation only)

NOTE: The colored wires which are permanently attached to the power transformer are covered in the circuit board hole wire check list. The following lug numbers refer to the solder lugs at the top of the transformer.

Lug 1 -- Two connections: bare wire to lug 3, power transformer; red wire to ON/OFF switch

Lug 2 -- One connection: bare wire to lug 4, power transformer

Lug 3 -- One connection: bare wire to lug 1, power transformer

Lug 4 -- Two connections: bare wire to lug 2, power transformer; ribbed wire of power cord

POWER TRANSFORMER -- (240 volt operation only)

NOTE: Power transformer is wired for either 120 volts or 240 volts but not both. If you do not know your line voltage, call your power company.

Lug 1 -- One connection: red wire to ON/OFF switch

Lug 2 -- One connection: bare wire to lug 3

Lug 3 -- One connection: bare wire to lug 2

Lug 4 -- One connection: ribbed wire of power cord

NOTE: The smooth wire from the power cord is attached to lug 2 of Fuse 2. The green wire of the power cord is connected to a solder lug which is attached by a machine screw to the back of the meter cabinet.

This completes the digital multimeter wiring check list. All connections should be made exactly as outlined in this wiring check list for proper operation of the meter. If you have any doubts about the proper connection, contact our Instruction Department for additional advice. At this point, there should be no unsoldered connections.

APPENDIX C

DIGITAL MULTIMETER TROUBLESHOOTING GUIDE
REPORT FORM

Name _____ Tel. No. () _____

Student Number _____

Address _____

City _____ State _____ Zip _____

1. The problem with the meter (is) (was)

2. If the meter is now working properly, disregard the remainder of this form.
If the meter is still not working, go on to item 3.

3. Check the appropriate boxes in the table below.

The meter works on:	YES	NO
DC Volts	_____	_____
AC Volts	_____	_____
DC Current	_____	_____
AC Current	_____	_____
Ohms	_____	_____

4. Measure and record the dc power supply voltages in the table below.

<u>Power Supply Voltage</u>	<u>Test Point</u>	<u>Tolerance</u>	<u>Actual Measured Value</u>
+5 Vdc	Emitter, Q11	±5%	_____
+15 Vdc	Cathode, D14	±10%	_____
-15 Vdc	Anode, D15	±10%	_____
+110 Vdc	Cathode, D16	±20%	_____

5. Check the appropriate spaces below:

I have completed the procedures in sections:	YES	NO
A	_____	_____
B	_____	_____
C	_____	_____
D	_____	_____
E	_____	_____
F	_____	_____
G	_____	_____

6. No analysis can be made without complete data on your test results. For those spaces you have checked "YES" above, record all results from each test and each step on a separate sheet of paper. Attach all test results to this form and send the entire package to the school in a brown Instruction Department envelope. Your test results should resemble the sample below.

Sample Test Result

Section A, Test 2, Step 3 9,900 Ohms

Note: For Section F, be sure to identify each check, e.g. Section F, Ramp Generator Check, Test 1, Step 1, etc.

NOTES

NOTES



