



CONSTRUCTION MANUAL

Model 377

MODEL 377-1

AUDIO SINE AND SQUARE WAVE GENERATOR

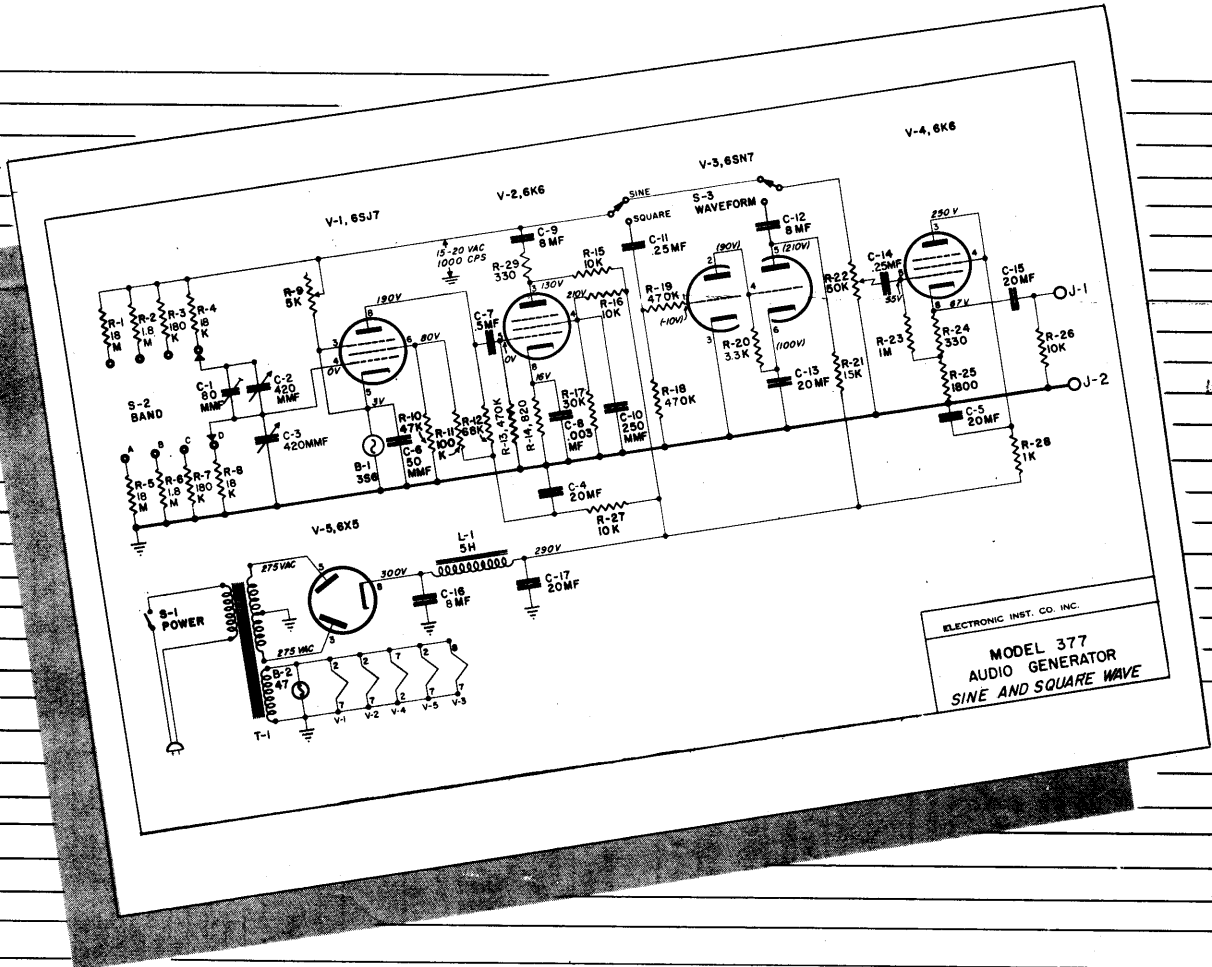

ELECTRONIC INSTRUMENT CO., Inc.

Reg. U. S. Pat. Off.

CAPACITOR COLOR CODES

RMA 3-DOT COLOR CODE FOR MICA-DIELECTRIC CAPACITORS

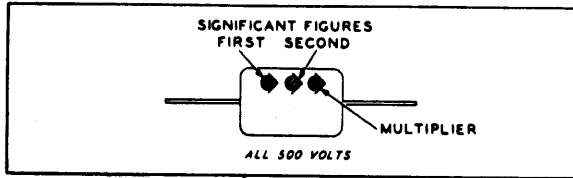

JAN 6-DOT COLOR CODE FOR PAPER-DIELECTRIC CAPACITORS

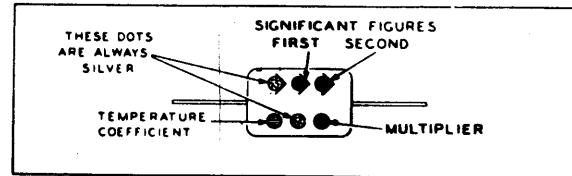

RMA 6-DOT COLOR CODE FOR MICA-DIELECTRIC CAPACITORS

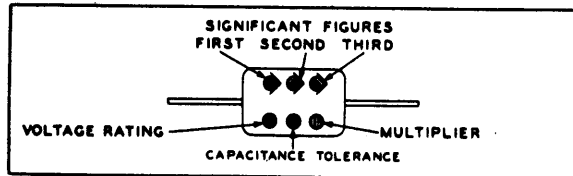

JAN 6-DOT COLOR CODE FOR MICA-DIELECTRIC CAPACITORS

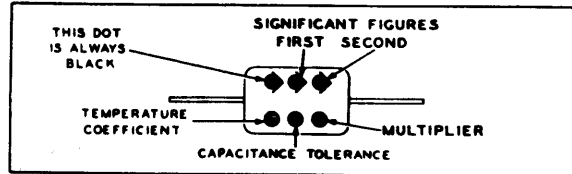

RMA COLOR CODE FOR TUBULAR CERAMIC-DIELECTRIC CAPACITORS

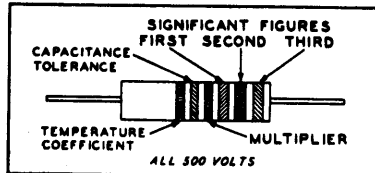

JAN COLOR CODE FOR FIXED CERAMIC-DIELECTRIC CAPACITORS

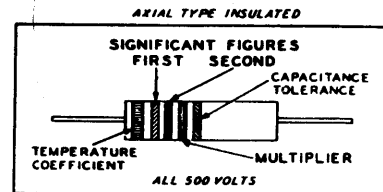
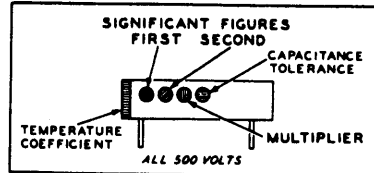

RMA: RADIO MANUFACTURERS ASSOCIATION
JAN: JOINT ARMY-NAVY

RESISTORS				CAPACITORS				
TOLERANCE	MULTIPLIER	SIGNIFICANT FIGURE	COLOR	MULTIPLIER			VOLTAGE RATING	TEMPERATURE COEFFICIENT
				RMA MICA AND CERAMIC-DIELECTRIC	JAN MICA AND PAPER-DIELECTRIC	JAN CERAMIC DIELECTRIC		
	1	0	BLACK	1	1	1		A
	10	1	BROWN	10	10	10	100	B
	100	2	RED	100	100	100	200	C
	1000	3	ORANGE	1000	1000	1000	300	D
	10000	4	YELLOW	10000			400	E
	100000	5	GREEN	100000			500	F
	1000000	6	BLUE	1000000			600	G
	10000000	7	VIOLET	10000000			700	
	100000000	8	GRAY	100000000		0.01	800	
	1000000000	9	WHITE	1000000000		0.1	900	
5	0.1		GOLD	0.1	0.1		1000	
10	0.01		SILVER	0.01	0.01		2000	
20			NO COLOR				500	

RESISTOR COLOR CODES

RMA COLOR CODE FOR FIXED COMPOSITION RESISTORS

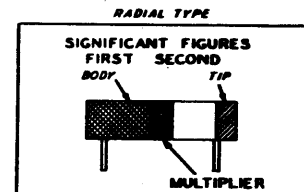
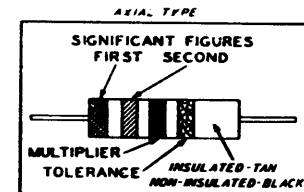

JAN COLOR CODE FOR FIXED COMPOSITION RESISTORS

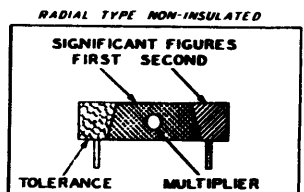
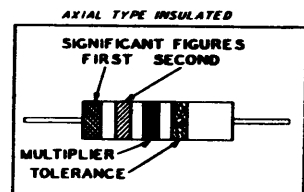

GENERAL INSTRUCTIONS

1) The Model 377 Audio Generator is constructed very easily with the aid of fully detailed perspective drawings and step-by-step instructions. Before starting the actual construction, it is advisable to study the schematic and pictorial wiring diagrams until all of the steps are clear in your mind. Do not rush the construction, as careful work will result in a properly constructed instrument in the shortest time. In addition, it is suggested that you run all leads exactly as shown on the pictorial wiring diagrams, as this will make the wiring an easier job and insure proper operation of the instrument.

2) USE A GOOD GRADE OF ROSIN CORE SOLDER ONLY. UNDER NO CIRCUMSTANCES USE ACID CORE SOLDER OR ACID FLUX inasmuch as the acid flux can cause serious corrosion. Before soldering, make certain there is a good mechanical connection. The solder must flow before you remove the soldering iron as this will prevent rosin joints which are poor electrical conductors. If you are soldering close to a part, hold the ends of a pair of longnose pliers between the part and the solder joint. The pliers will conduct the heat away and prevent the component from being unduly overheated.

3) Carefully unwrap all the parts and check them in the space provided on the parts list. Note: In order to maintain the supply of kits and insure prompt delivery, we are forced to buy the same component from several sources (standard manufacturers' parts are interchangeable). You may find that the value of a component will vary within the allowable circuit tolerance. This means a resistance of 470,000 ohms may be substituted for, or may measure 510,000 ohms, etc. Any part supplied will work as well as the part for which it was substituted. No substitutions will be made on precision components.

CONSTRUCTION PROCEDURE

For your convenience, the construction of the instrument has been broken down into a logical series of Assembly Prints. Each Assembly Print consists of a detailed drawing and a table of step-by-step instruction so that no step can be overlooked. Space has been provided on the tables to check off each step as it is completed. Follow the order of the Assembly Prints to finish the mechanical assembly and the wiring quickly and easily.

PARTS LIST FOR MODEL 377

Stock#	Sym.	Description	Am't.	Stock#	Sym.	Description	Am't.	Stock#	Sym.	Description	Am't.
92001	B1	lamp, 356 - 3W	1	43001	H17	lug, 3/8 ground	1	10811	R11	res., 100KΩ, 1W	1
92000	B2	lamp, #47	1	42006	H18	washer, 1/4 fibre shoulder	2	10023	R12	res., 68KΩ, 1/2W	1
29507	C1	cap., trimmer, 5-80mmf	1	42003	H19	washer, 1/4 fibre flat	4	10028	R13, 18		
29005	C2, 3	cap., tuning, 2X420mmf	1	83000	H20	Insulated coupling	1	19	res., 470KΩ, 1/2W	3	
24001	C4, 17	cap., elec. 2X20mf-450V	1	42002	H21	washer, #6 lock	17	10871	R14	res., 820Ω, 1W	1
24001	C5, 13	cap., elec. 2X20mf-450V	1	40000	H22	nut, #6 hex	15	14002	R15	res., 10KΩ, 10W	1
22000	C6	cap., ceramic, 50mmf	1	41000	H23	screw, #6 X 1/4	7	10904	R16	res., 10KΩ, 2W	1
20005	C7	cap., paper, .5mf	1	41002	H24	screw, #6 P.K.	9	10906	R17	res., 33KΩ, 2W	1
20007	C8	cap., .003mf paper,	1	53000	H25	knob, bar	2	10038	R20	res., 3.3KΩ, 1W	1
23002	C9, 12	Cap., elec. 8mf-350V	2	53500	H26	knob, w/ plastic pointer	1	10819	R21	res., 15KΩ, 1W	1
21001	C10	cap., 270 mmf, mica	1	58000	H27	wire, hook-up	length	16004	R22	pot., 50KΩ	1
20004	C11, 14	cap., paper, .25mf	2	58501	H28	wire, bare	length	10030	R23	res., 1MΩ, 1/2W	1
23004	C15	cap., elec. 20mf-150V	1	57000	H29	line cord	1	10862	R24	res., 330Ω, 1W	1
23005	C16	cap., elec. 8mf-450V	1	82000	H30	shaft, 1/4" D	1	10751	R25	res., 1800Ω, 5W	1
80040	H1	panel	1	40003	H31	nut, 15/32" D hex & round	2	10016	R26, 27	res., 10KΩ, 1/2W	2
81061	H2	chassis	1	46000	H32	grommet, 3/8	4	10902	R28	res., 1KΩ, 2W	1
88002	H3	cabinet	1	87000	H33	handle	1	10042	R29	res., 330Ω, 1/2W	1
81013	H4	shield	1	41001	H34	screw, #10-24 X 1/4	2	61000	S1	switch SPST, toggle	1
97700	H5	pilot light assembly	1	85000	H35	bushing	1	60016	S2	switch, 2P 4Pos., rotary	1
97705	H6	lamp socket (3S6)	1	58300	H36	spaghetti	length	62000	S3	switch, 2P 2 Pos., slide	1
97003	H7	octal socket *	5	52000	J1, 2	binding post	2	30002	T1	transformer, power	1
41016	H8	screw, #4-40x 1/4	2	34000	L1	choke, 5 Hy.	1	54000	TB1, 2, 3	terminal strip, 1 post left. *	3
40007	H9	nut, hex #4-40	2	11702	R1, 5	res., 18MΩ, 1%	2	54003	TB4	terminal strip, 2 post *	1
59500	H10	mounting plate *	2	11053	R2, 6	res., 1.8MΩ, 1%	2	90006	V1	tube, 6SJ7	1
43000	H11	ground lug	6	11054	R3, 7	res., 180KΩ, 1%	2	90005	V2, 4	tube, 6K6	2
42000	H12	lock washer, 3/8	4	11055	R4, 8	res., 18KΩ, 1%	2	90019	V3	tube, 6SN7	1
42001	H13	flat washer, 3/8	2	18009	R9	pot., 5KΩ, min.	1	90009	V5	tube, 6X5	1
40001	H14	nut, 3/8 hex	4	10022	R10	res., 47KΩ, 1/2W	1				
42006	H15	washer, 1/4 fibre shoulder	3								
58500	H16	wire, heavy bare	length								

* riveted to chassis

Model 377

ASSEMBLY PRINT 1

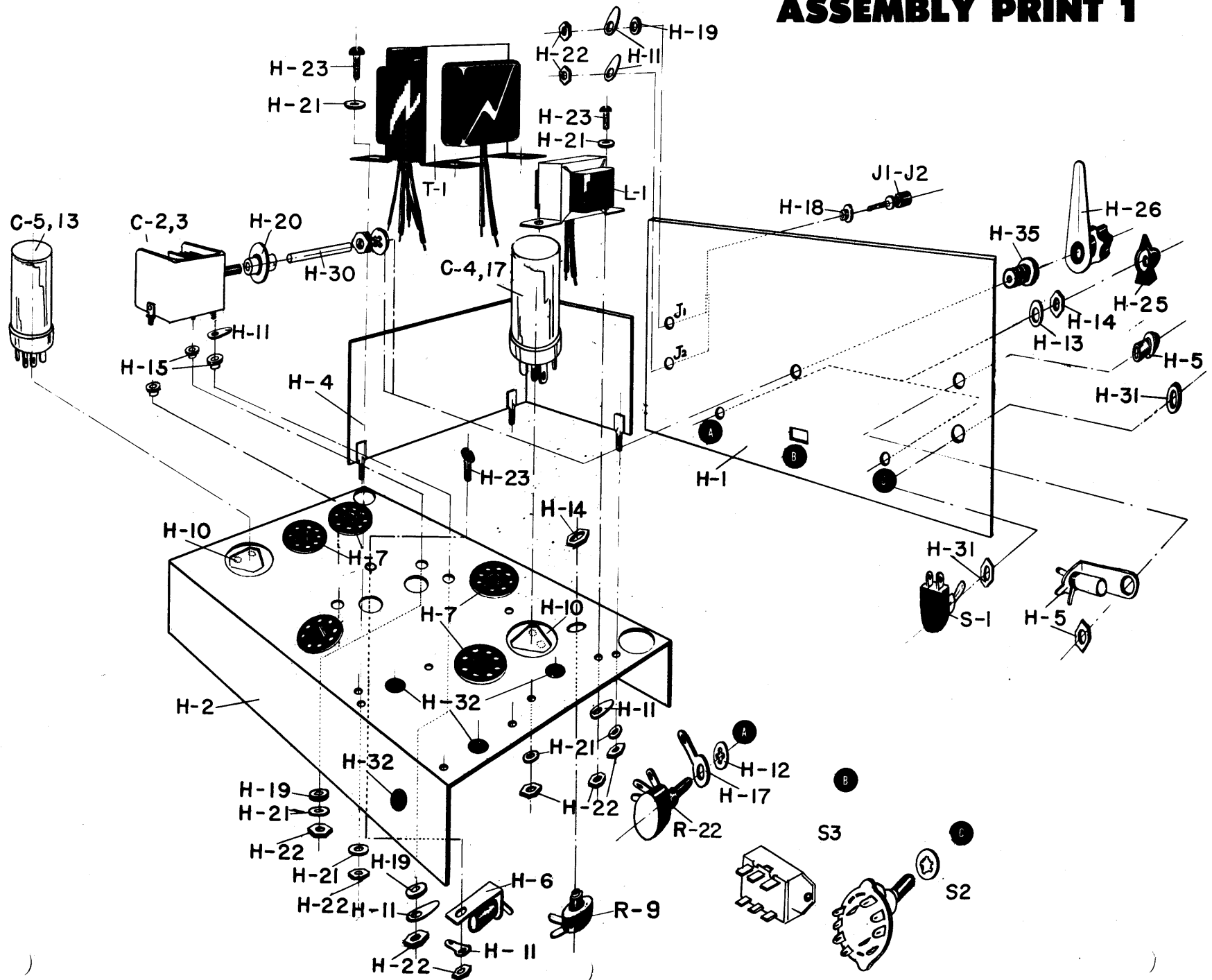

Assembly Print 1 covers the entire mounting procedure. The step-by-step mounting table allows you to complete the mounting in a systematic manner. All the parts that are needed to mount a component are given by symbol number in the "Mounted With-(Remarks)" column. (Refer to the parts list for the descriptions corresponding to each symbol number). The method and location of mounting is shown in the drawing. For example, refer to step 1-1 in the mounting table and gather together all the parts called for. Locate the 3S6 lamp socket in the drawing. Notice the light broken line that passes through the lamp socket and traces a path to the mounting hole in the chassis. On this broken line you will find all the hardware called for in this step, strung out in the order that they take in the mounting. When you have mounted the lamp socket, place a check opposite 1-1 in the mounting table. The remaining steps are completed in the same manner.

To keep the drawing uncrowded, unnecessary repetition is avoided. For example, transformer T1 is fastened to the chassis by all four mounting brackets, whereas the method of mounting is shown at only one bracket. The drawings of Assembly Prints 2 and 3 may be referred to when a bottom view of the chassis would be helpful. Be sure that the plates of the main tuning condenser, C2, 3, are fully meshed when the condenser is being handled or mounted. Otherwise the plates may be bent, thus affecting the calibration.

MOUNTING

<u>✓ Step#</u>	<u>Sym.</u>	<u>Description</u>	<u>Mounted With (Remarks)</u>
1-1	H6	lamp socket (3S6)	1#H23, 1#H22, 1#H11
1-2	R9	5K ohm pot	1#H14
1-3	H4	shield	3#H21, 3#H22
1-4	H32	3/8 rubber grommet	4 on chassis
1-5	T1	power xfmr	4#H23, 8#H21, 4#H22
1-6	L1	5 hy. filter choke	1#H11, 3#H21, 2#H22, 2#H23
1-7	C4, 17	dual 20 mf cond.	twist prongs
1-8	C5, 13	dual 20 mf cond.	twist prongs
1-9	J1	binding post	1#H18, 1#H19, 1#H11, 1#H22
1-10	J2	binding post	1#H18, 1#H11, 1#H22
1-11	H5	pilot lamp ass'y.	with associated hdwe.
1-12	S1	power switch	2#H31
1-13	S3	2 pole, 2 pos. switch	2# H8, 2#H9
1-14	*R22	50K pot	1#H14, 1#H13, 1#H12, 1#H17
1-15	*S2	2 pole, 4 pos. switch	1#H14, 1#H13, 1#H12
1-16	C 2, 3	main tuning cond.	2#H11, 3#H15, 3#H19, 2#H21, 3#H22
1-17	H35	bushing	1#H12, 1#H14
1-18	H20	coupling	
1-19	H30	1/4 dia. shaft	

*The mounting of R22 and S2 also serves the purpose of fastening the front panel to the chassis. See drawing.

Note: Be careful not to mar the front of the panel when fastening components to it.

STEP#1-19: KNOB PLACEMENT

- a) Place the bar knobs, H25, over the shafts of S2 and R22 and tighten the set screws.
- b) Place the pointer-and-knob, H26, over the shaft, H30 (coupled to C2, 3), and tighten the set screw.
- c) Turn all knobs counter-clockwise as far as they will go.
- d) Now loosen all set screws.
- e) Line up the bar knob on S2 with the marker for band A and tighten the set screw.
- f) Line up the bar knob on R22 with the zero mark on the AMPL. dial and tighten the set screw.
- g) Line up the hairline of the pointer-and-knob with the zero mark on the 0 to 100 reference scale of the frequency dial, and tighten the set screw.

All knobs now indicate properly.

RECOMMENDED TOOLS

Assorted screwdrivers (flat), 1/4" nut driver, 5" or 6" long needle nose and side cutting pliers, 5" or 6" diagonal cutting pliers, 100 watt soldering iron with small tip.

WIRING

You have now completed all the required mounting. The rest of the working instructions are for wiring only. In the wiring tables that follow, the following abbreviations are used: (C) means that you are to make a mechanical connection without soldering, (S) means that you are to make the connection and solder. This is done so that you will have to solder each joint only once (after all the wires and components connected to the joint have been wired in).

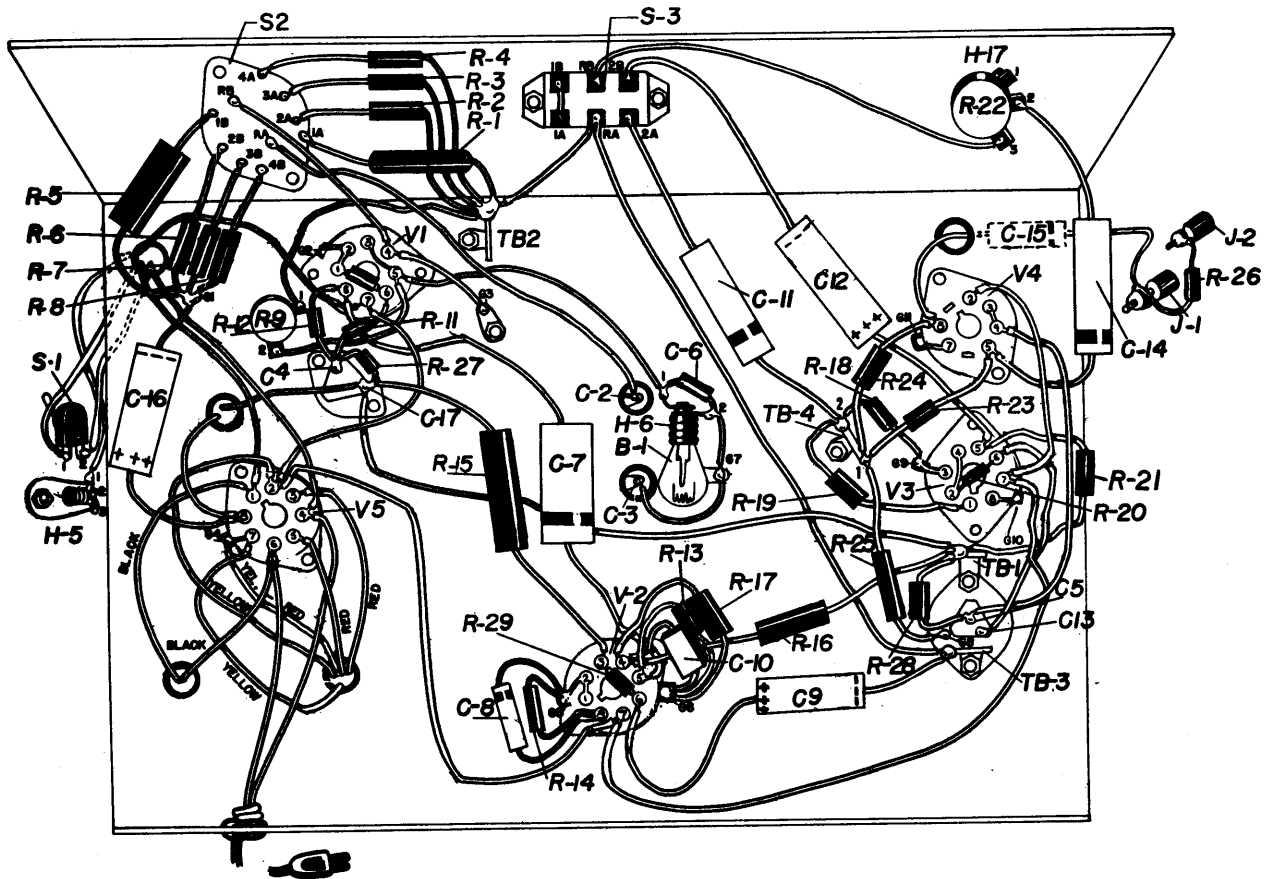

Model 377 ASSEMBLY PRINT 2

✓	Step#	Sym.	Description	From	To	✓	Step#	Sym.	Description	From	To
	2-1	T1	yellow wire		V5#7 (C)		2-21	H27	hook-up wire	(C) C17	TB1-1 (C)
	2-2	T1	red-yellow wire		G4 (C)		2-22	R15	res., 10KΩ, 10W	(S) C17*	V2#3 (C)
	2-3	H28	bare wire	(S) V5#7	G4 (S)		2-23	R12	res., 68K	(C) C4 *	V1#8 (C)
	2-4	T1	red wire		V5#5 (S)		2-24	R11	res., 100K, 1W	(S) C4	V1#6 (C)
	2-5	T1	red wire		V5#3 (S)		2-25	R10	res., 47K	(S) V1#6	V1#1 (C)
	2-6	T1	yellow wire		V5#2 (C)		2-26	H28	bare wire	(S) V1#1	V1#2 (C)
	2-7	T1	black wire		V5#1 (C)		2-27	H28	bare wire	(S) V1#2	G2 (S)
	2-8	T1	black wire		V5#6 (C)		2-28	H27	hook-up wire	(C) V1#5	R9#2 (S)
	2-9	L1	black wire		C17 (C)		2-29	H28	bare wire	(C) V1#5	V1#3 (S)
	2-10	L1	black wire		V5#8 (C)		2-30	H27	hook-up wire	(S) V1#5	H6#1 (C)
	2-11	R8	res., 18KΩ	(S) S2#4B	G1 (C)		2-31	C6	cap., 50mmf	(S) H6#1	H6#2 (C)
	2-12	R7	res., 180KΩ	(S) S2#3B	G1 (C)		2-32	R4	res., 18KΩ	(S) S2#4A	TB2#1 (C)
	2-13	R6	res., 1.8MΩ	(S) S2#2B	G1 (C)		2-33	R3	res., 180KΩ	(S) S2#3A	TB2#1 (C)
	2-14	R5	res., 18MΩ	(S) S2#1B	G1 (C)		2-34	R2	res., 1.8MΩ	(S) S2#2A	TB2#1 (C)
	2-15	C16	cap., 8 mfd	(S) V5#8*	G1 (S)		2-35	R1	res., 18MΩ	(S) S2#1A	TB2#1 (C)
	2-16	R27	res., 10KΩ, 1/2W	(C) C17	C4 (C)		2-36	H27	hook-up wire	(S) R9#1	TB2#1 (C)
	2-17	H27	hook-up wire	(C) V5#2	V1#7 (C)		2-37	H27	hook-up wire	(S) TB2#1	S3#RA (C)
	2-18	H27	hook-up wire	(S) V5#2	V2#7 (C)		2-38	H27	hook-up wire	(C) V1#4	S2#RB (S)
	2-19	H27	hook-up wire	(S) V2#7	V3#7 (C)		2-39	H27	hook-up wire	(S) V1#4	G3 (S)
	2-20	H27	hook-up wire	(S) V3#7	V4#2 (S)		2-40	H27	hook-up wire	(S) S2#RA	C2 (S)

* With spaghetti

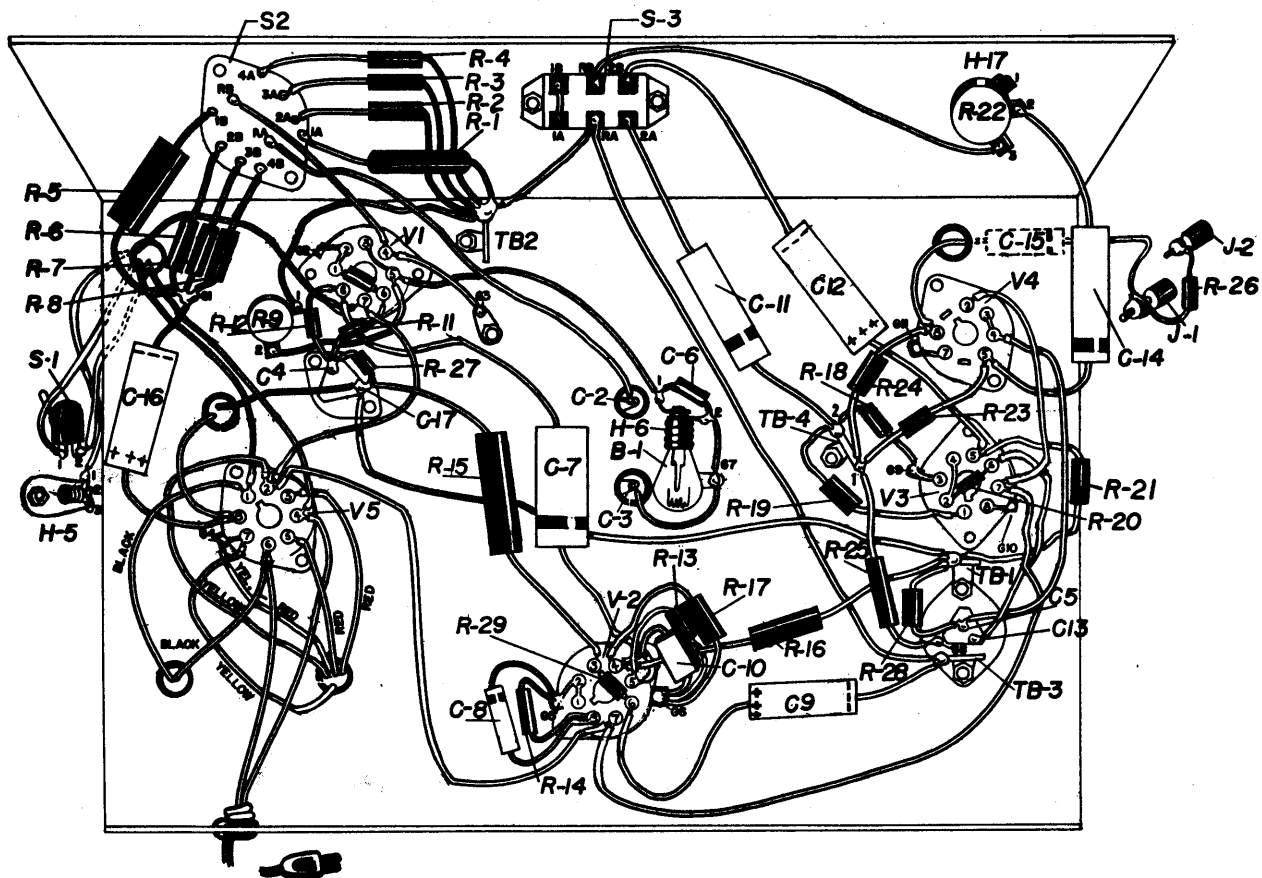

Model 377 ASSEMBLY PRINT 2

✓	Step#	Sym.	Description	From	To	✓	Step#	Sym.	Description	From	To
	2-41	R17	res., 33K, 2W	(C) V2#4	G6 (C)		2-61	H28	bare wire	(S) V3#3	G9 (S)
	2-42	C10	cap., 250mmf	(C) V2#4	G6 (C)		2-62	R19	res., 470KΩ	(C) TB4#2	V3#1 (S)
	2-43	R16	res., 10K, 2W	(S) V2#4 *	*TB1-1 (C)		2-62	C11	cap., .25mf	(S) TB4#2	*S3#2A(S)
	2-44	R13	res., 470K	(C) V2#5	G6 (S)		2-63	H27	hook-up wire	(S) C13	V3#6 (C)
	2-45	C7	cap., .5 mf	(S) V2#5*	*V1#8 (S)		2-64	R20	res., 3.3KΩ	(S) V3#6	V3#2 (C)
	2-46	R29	res., 330Ω	(S) V2#3	V2#6 (C)		2-65	H28	bare wire	(S) V3#2	V3#4 (S)
	2-47	R14	res., 820Ω	(C) V2#8	G5 (C)		2-66	H27	hook-up wire	(S) C5	V4#4 (C)
	2-48	C8	cap., .003mf	(S) V2#8	G5 (C)		2-67	H28	bare wire	(S) V4#4	V4#3 (S)
	2-49	H28	bare wire	(S) V2#1	V2#2 (C)		2-68	H28	bare wire	(S) V3#8	G10 (S)
	2-50	H28	bare wire	(S) V2#2	G5 (S)		2-69	C12	cap., 8mf	(C) V3#5*	*S3#2B(S)
	2-51	C9	cap., 8mf	(S) V2#6 *	*TB3#1 (C)		2-70	R21	res., 15KΩ	(S) V3#5*	TB1#1 (S)
	2-52	H27	hook-up wire	(S) H6#2	G7 (C)		2-71	H28	bare wire	(S) V4#7	G11 (S)
	2-53	H27	hook-up wire	(S) G7	C3 (S)		2-72	C14	cap., .25mf	(S) V4#5*	*R22#2 (S)
	2-54	H27	hook-up wire	(S) TB3#1	S3#RA(S)		2-73	H17	ground lug	under R22	R22#1 (S)
	2-55	H28	bare wire	(S) S3#1B	S3#1A(S)		2-74	H27	hook-up wire	(S) R22#3	S3#RB(S)
	2-56	R28	res., 1K, 2W	(S) TB1#1	C5 (C)		2-75	H27	hook-up wire	(S) V5#1	S1#1 (S)
	2-57	R25	res., 1800Ω, 5W	(S) G8	*TB4#1 (C)		2-76	H27	hook-up wire	(C) V5#4	S1#2 (S)
	2-58	R23	res., 1MΩ	(C) TB4#1	V4#5 (C)		2-76	H27	hook-up wire	(S) V1#7	H5#1 (S)
	2-59	R24	res., 330Ω, 1W	(S) TB4#1**	V4#8 (C)		2-77	H28	bare wire	(S) H5#2	H5#3 (S)
	2-60	R18	res., 470KΩ	(C) TB4#2	G9 (C)		2-78	H29	line cord **		V5#4 (S)
							2-79	H29	line cord **		V5#6 (S)
							2-80	C15	cap., 20mf	(S) V4#8*	*J1 (C)
							2-81	R26	res., 10K	(S) J1	J2 (S)

*With spaghetti

WIRING OF THE MAIN TUNING CONDENSER

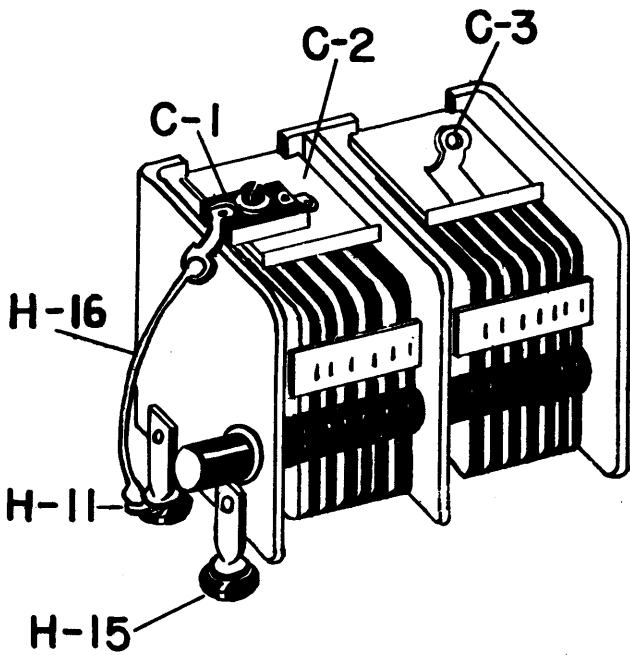

√ Step ^f	Sym.	Description	From	To
3-1	C1	** 80 mmf trimmer cond.	(S) H11	(S) C2

**Solder 2 1/2" length of heavy bare wire (H16) to ground lug H11. Be sure that H11 is not shorted to the chassis. Place C1 in position so that the heavy bare wire passes through the terminal lug at one end and the other terminal lug rests on the contact of C2. Solder at both ends. Be sure that C1 is well away from the frame of the main tuning condenser.

FINAL STEPS

You have now finished the mechanical assembly and wiring of your instrument. When you have completed the following steps, your instrument will be in operating condition.

1. Screw the 3 watt lamp (B1) into its socket (H6) on the bottom side of the chassis.
2. Insert the tubes and pilot light as shown in the figure below.

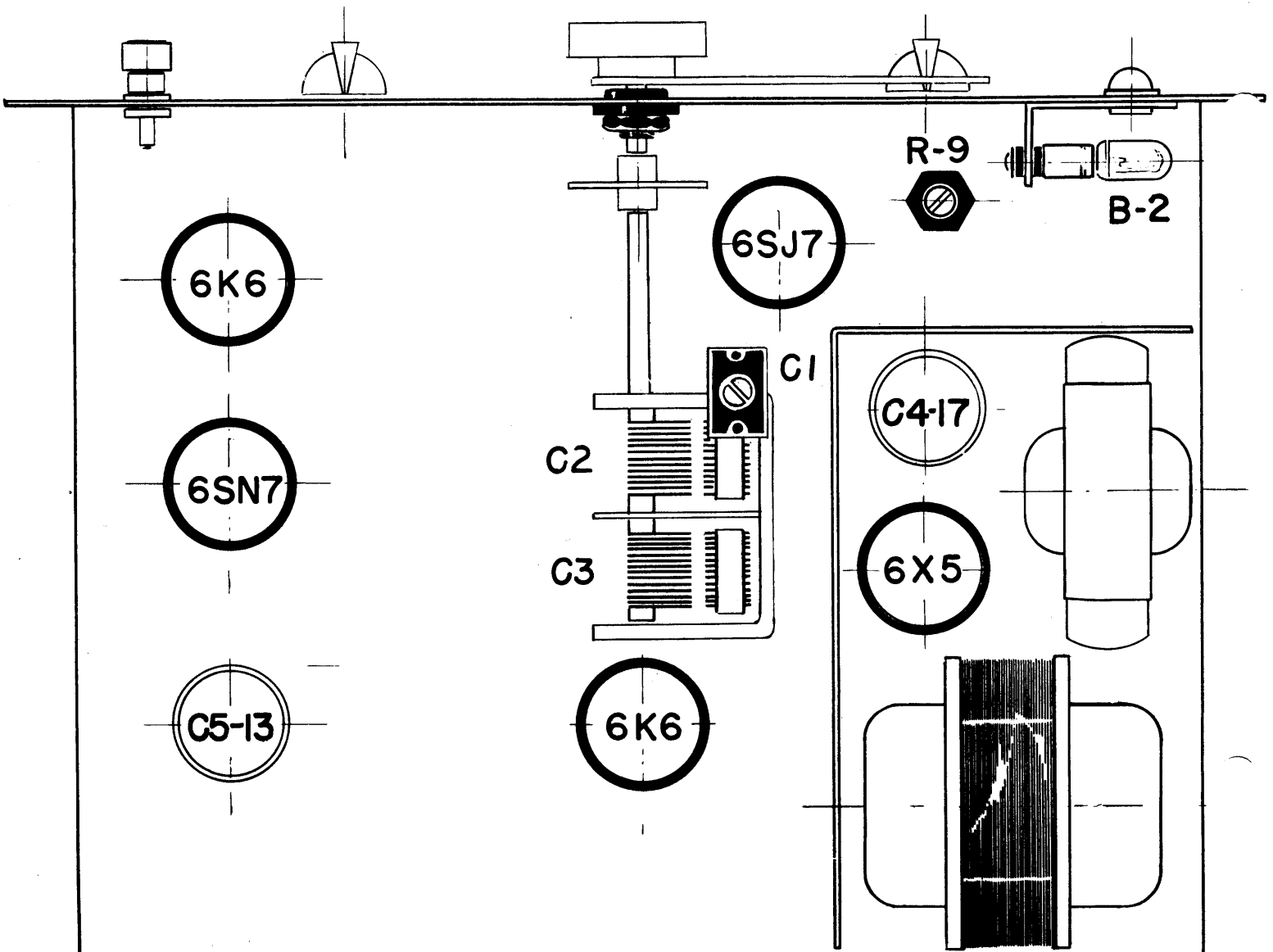

3. Make a careful examination of the entire chassis to determine whether all joints are soldered properly (no rosin joints), and that there is no rosin between tube socket lugs or switch contacts to cause leakage. Make sure that there are no loose lumps of solder in the chassis that may result in shorts. Also straighten out the wiring and the components so that there are no accidental shorts.

4. If you have an ohmmeter, measure the resistance from pin 8 of V5 to ground (before connecting the instrument to the power line). You will notice that the ohmmeter reading increases steadily as the ohmmeter battery charges the filter condensers of the unit. The final reading should be at least 35,000 ohms. If the reading is less than 100,000 ohms, DO NOT TURN THE INSTRUMENT ON, but carefully recheck the wiring of the power supply circuit.

5. Measure the resistance from the frame of the main tuning condenser to ground. When the BAND switch is set at band A, this resistance should be 18 megohms. If the resistance is much lower, check the fibre washers that insulate the condenser frame from the chassis.

6. Calibrate the instrument by one of the three methods described in the MAINTENANCE section of the Instruction Book.

7. Mount the handle on the cabinet with the two #10-24 X 1/4" screws (H34). Insert the chassis in the cabinet, securing it with the #6 X 1/4" P.K. screws (H24). Both of these steps are shown in the figure below.

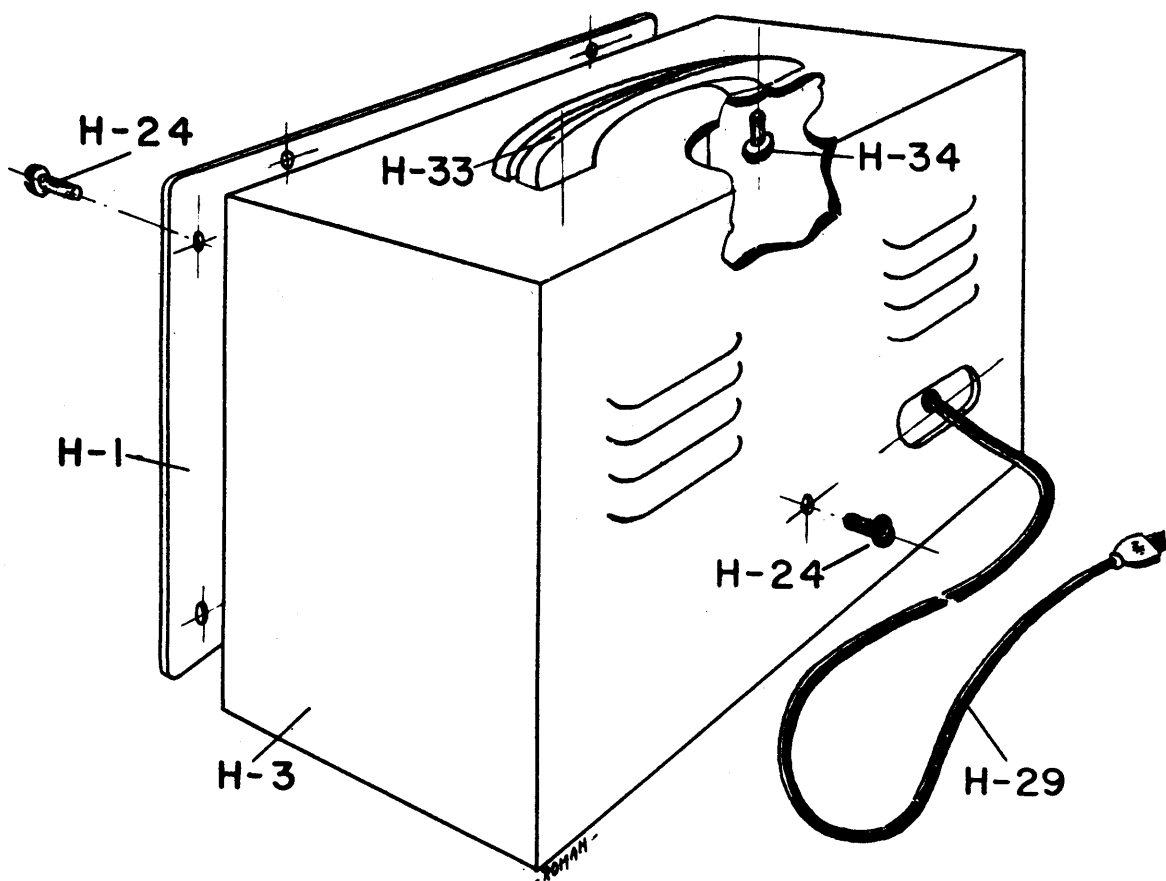

If the instrument fails to operate properly, make certain that the wiring and the components in the circuit are correct. Almost all troubles reported to us in the past, have had improper wiring as their cause. If the wiring is correct, test for continuity and check individual components for breakdown. If you have a high input impedance VTVM, such as the EICO Model 214 or 221, check the voltages shown on the schematic diagram. The voltages shown in parenthesis are measured with the WAVEFORM selector switch set at SQUARE. The other voltages are measured with the WAVEFORM selector switch set at SINE. All voltages may vary from the values shown by as much as 20%. Failure to obtain the proper voltages at any point should indicate where to look for the trouble.

If you are still having difficulty, write to our engineering department (Electronic Instrument Co., Inc., 33-00 Northern Blvd., L.I.C. 1, New York) listing all indications which might be helpful. If desired, you may return the instrument to our factory, where it will be placed in operating condition and calibrated for \$5.00 plus the cost of parts replaced due to their being damaged in the construction of the instrument. Pack the unit very carefully; in the original shipping carton, if possible. Send it to the above address, prepaid Railway Express. The instrument will be returned as soon as possible, express collect.

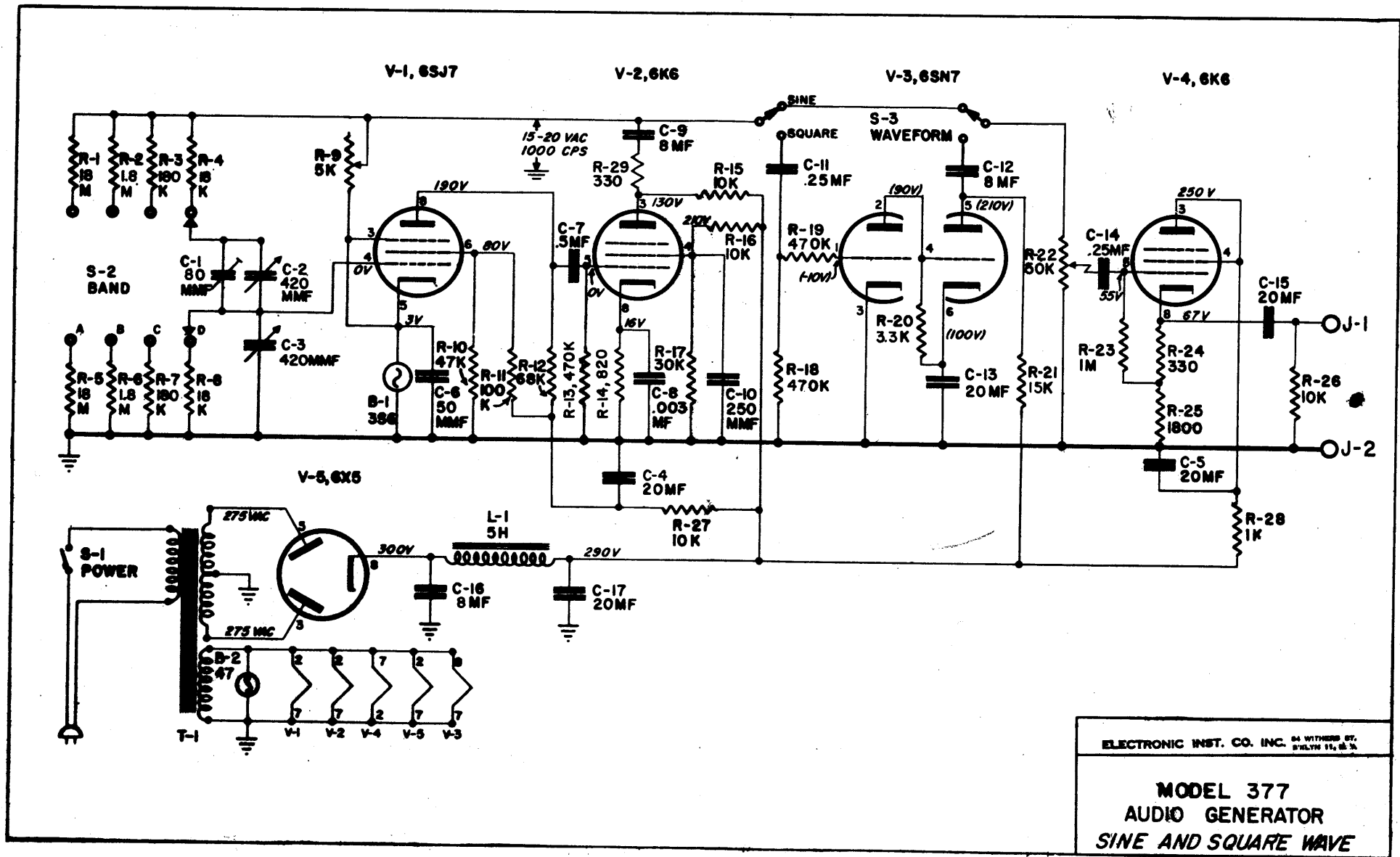

ELECTRONIC INST. CO. INC. 84 WITHERS ST. BOSTON 11, MASS.

MODEL 377
AUDIO GENERATOR
SINE AND SQUARE WAVE

Model 377 AUDIO SINE AND SQUARE WAVE GENERATOR 