

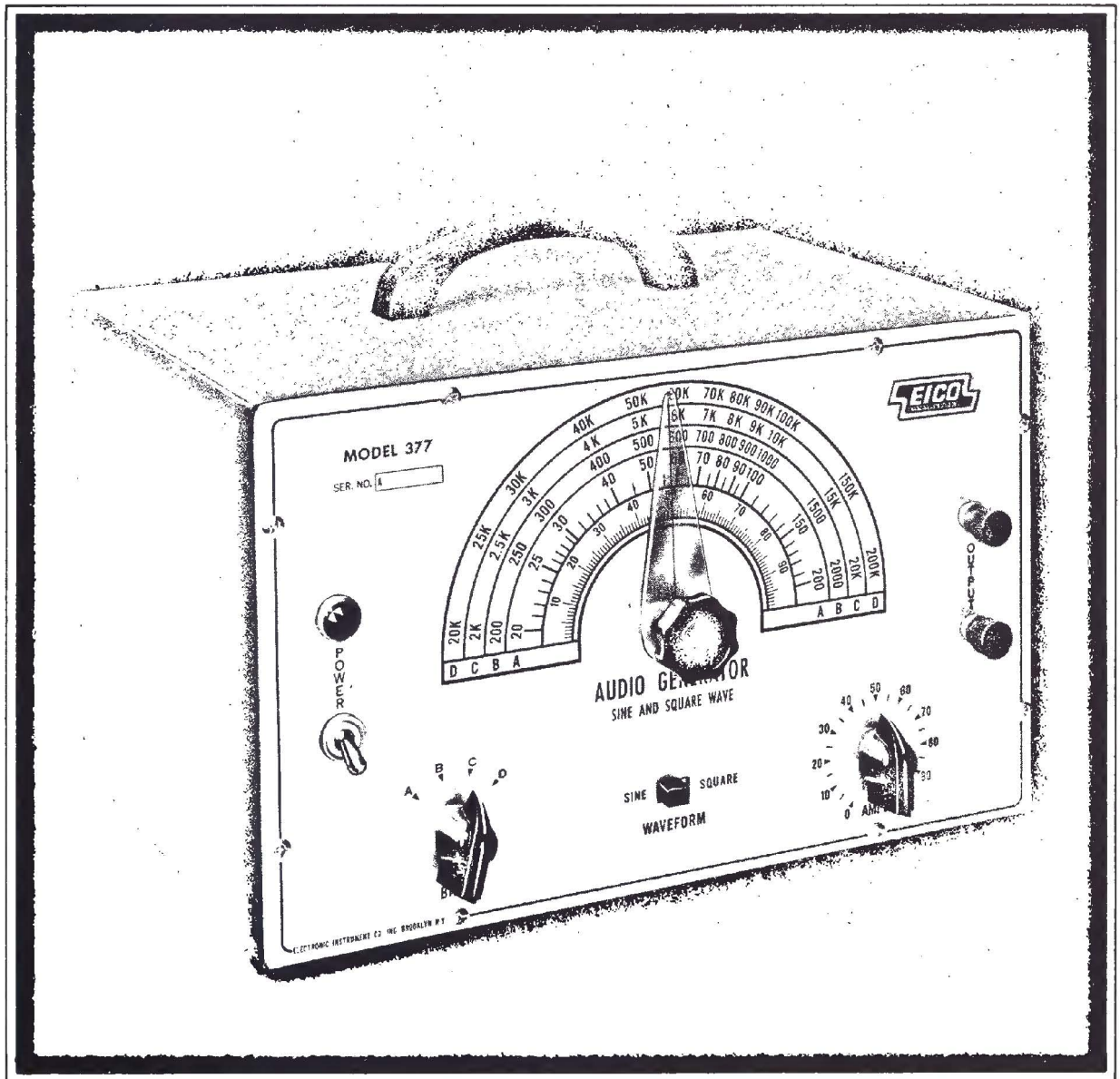

377 | Sine/Square Wave Audio Generator



OPERATING MANUAL

GENERAL DESCRIPTION

The EICO Model 377 is an audio sine and square wave generator providing sine wave voltages throughout the frequency range of 20 to 200,000 Hz and useful square wave voltages throughout the frequency range of 60 to 30,000 Hz. The entire frequency spectrum is covered in four ranges, providing a long effective scale length for maximum accuracy and readability. A linear 0 to 100 scale is also provided for reference purposes.

The 377 is an adjustable vacuum-tube oscillator utilizing the widely-accepted resistance-capacitance tuning circuit that has been used for years in the finest laboratory generators. The frequency of oscillation is controlled with a capacitance-resistance filter (Wien Bridge) in a circuit which is highly degenerative except at the pass frequency of the filter; the circuit oscillates at this frequency. The Wien Bridge is composed of 1% precision resistors and a large 2 gang tuning condenser for accurate frequency determination and wide-band coverage. This generator possesses a high degree of frequency stability and requires a very short warm-up time to attain stable operation. The harmonic distortion in the output is less than 0.5%, giving a purity of waveform equalled only by the finest power generating stations. Although this instrument provides only sine and square waves, any desired waveform can be produced with an external R-C circuit (inserted between the generator and the load).

A cathode follower output circuit enables the instrument to deliver at least 10 volts across a 1000 ohm load (100 milliwatts) and to maintain high output without appreciable distortion when feeding into larger loads. The frequency response is flat ± 1.5 db from 60 Hz to 150 kHz. The hum is kept down to less than 0.4% of the rated output by a full wave rectifier and a pi type LC filter, plus additional RC filtering.

This instrument will prove itself extremely useful in determining radio receiver fidelity and loudspeaker response, audio amplifier testing and design, and for square wave testing of television receivers.

SPECIFICATIONS

Sine Wave Range: 20 - 200,000 Hz in 4 bands; the dial can be read directly on all ranges.

Band A: 20 - 200 Hz
Band B: 200-2000 Hz

Band C: 2000 - 20,000 Hz
Band D: 20,000 - 200,000 Hz

Square Wave Range: 60 - 30,000 Hz (5% tilt at 60 Hz, 5% rounding at 30 kHz). Read on same scales as sine waves.

Calibration Accuracy: $\pm 3\%$ or 1 Hz, whichever is greater

Frequency Response: ± 1.5 db, 60 Hz - 150 kHz

Output Voltage: The output circuit employed is of the cathode follower type. The table below gives the minimum output voltages that can be expected when the generator is feeding into different load impedances.

1,000 ohms	- 10 volts - 1% max. distortion
10,000 ohms and higher	- 14 volts - 1% max. distortion
500 ohms	- 8 volts - 1.5% max. distortion

These voltages are given for sine wave output and are unvarying with frequency; on square wave, the output voltages (r. m. s. values) are somewhat higher.

Rated Load: 1000 ohms (resistive)

Rated Output Power: 100 milliwatts into rated load (10 volts across a 1000 ohm resistive load).

Distortion: Less than 1% of rated output

Hum: Less than 0.4% of rated output

Power Requirements: 105 - 125 volts, 50 - 60 Hz, 50 watts

Tube Complement: 1 - 6SJ7, 1 - 6AQ5A, 1-6FQ7, 1-6BQ5, 1-3S6 3 watt lamp (G. E. lamp designation), 2-800 PIV silicon rectifiers

Overall Dimensions: 11 1/8" long, 7 1/8" high, 7 5/8" deep

Weight: 11 pounds

OPERATING INSTRUCTIONS

1. Preliminary Steps: Insert the plug on the line cord into the a-c supply. Snap on the power switch (the pilot lamp should light), and allow a few minutes for the unit to warm up and begin to oscillate. If very accurate work is to be done, allow a ten minute warm-up for the unit to reach complete stability.

2. Waveform Selection: Set the WAVEFORM selector switch to "SINE" or "SQUARE" as desired.

3. Frequency Selection: Set the BAND selector switch to the desired frequency band. Each position on the BAND switch corresponds to a direct reading scale on the dial, as follows:

Band A: 20 - 200 Hz
Band B: 200 - 2000 Hz

Band C: 2 kHz - 20 kHz
Band D: 20 kHz - 200 kHz

Turn the frequency dial knob until the hairline on the indicator lines up with desired frequency (on the scale corresponding to the band selected). The linear 0-100 scale on the frequency dial is useful when it is required to repeat a given setting.

4. Output: The output voltage is obtained from the two terminal posts at the right hand side of the front panel. The lower of the two posts is grounded to the chassis.

Output power is varied by means of the attenuator control (marked AMPLitude) on the front panel. Clockwise rotation of the control knob increases the output power to its maximum value.

If a small signal voltage having a high signal-to-noise ratio is required, it is advisable to obtain it from a large signal voltage and an external voltage dividing network. This method is preferable because the noise in the generator output is constant (0.4% of rated output), and therefore a larger output has a higher signal-to-noise ratio which carries over to the small voltage taken from the dividing network. The voltage divider network shown in Fig. 1 is suitable for most applications.

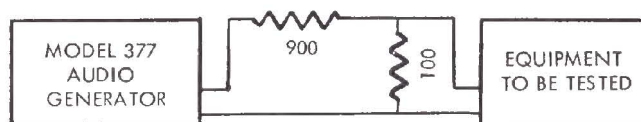

FIG. 1

Different sets of resistors may be used in the dividing network to obtain other voltage divisions. In all cases, however, the total of the two resistances should be at least 1000 ohms.

APPLICATIONS

Frequency Measurement: The Model 377 Audio Generator can be used to measure frequency by comparison.

With Headphones: Connect the output of the Audio Generator to one of a pair of headphones. The signal of unknown frequency is fed to the other headphone. Put the headphones on and tune the generator for "zero beat." The reading on the tuning dial of the generator is the unknown frequency.

With an Oscilloscope: Connect the Audio Generator to the horizontal axis of the 'scope. Then apply the unknown frequency to the vertical axis. The 'scope controls (or the input voltages) are now adjusted for roughly equal deflections on each axis. Vary the frequency of the Audio Generator until the 'scope pattern is a stationary ellipse, a circle, or a diagonal line of fixed length. The shape of the pattern depends on the phase relationship between the known and unknown signals (See Fig. 2). The unknown frequency is now equal to the frequency of the Audio Generator as read on the tuning dial. Non-sinusoidal waves will produce distorted forms of a single loop pattern or a diagonal line of uneven brightness.

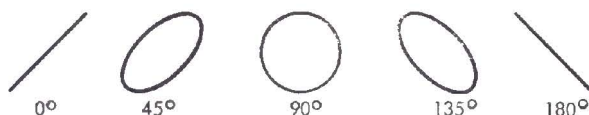

FIG. 2

Frequencies out of the Audio Generator's range can be measured by means of Lissajous figures. Lissajous figures are stationary closed-loop patterns that appear on the screen when the frequency applied to one set of plates is a whole number of times larger than the frequency applied to the other set of plates, or if one frequency is a simple fraction of the other. To determine frequency ratio from the Lissajous figure, count the number of points of tangency to horizontal and vertical lines, drawn or imagined (See Figures 3a, 3b, 3c, 3d, 3e, and 3f). Points of tangency at the top of the figures result from the unknown frequency applied to the vertical axis. Those at the side of the figure result from the known frequency of the Audio Generator applied to the horizontal axis. As a matter of fact, the following relationship holds true in all cases:

$$\frac{\text{Frequency applied to the vertical axis}}{\text{Frequency applied to the horizontal axis}} = \frac{\text{Horizontal points of tangency}}{\text{Vertical points of tangency}}$$

As an example, take Fig. 3c, which shows four points of tangency at the top and one point at the side. This indicates that the unknown frequency applied to the vertical axis is four times the known frequency. In Fig. 3f, one point of tangency at the top and four at the side indicate that the unknown frequency is one fourth the known frequency.

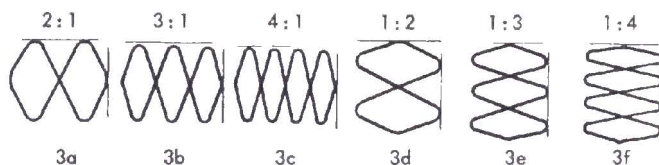

FIG. 3

Square Wave Testing: The square wave signal provided by the Model 377 Audio Generator can be used to check amplifiers as to frequency response, phase shift, transient response, deficient design, or faulty components. In addition to the generator, an oscilloscope with sufficiently wide frequency response is needed to carry out the tests. The equipment is set up as shown in Fig. 4.

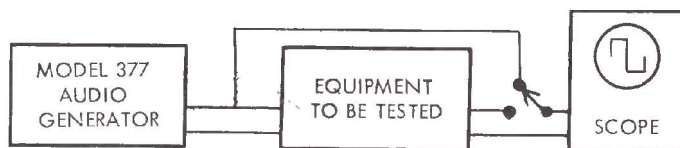

FIG. 4

First, as a means of comparison, the square wave output from the Audio Generator is viewed on the 'scope. The horizontal sweep of the 'scope should be adjusted so that at least two full cycles can be seen on the screen. (Fig. 5a shows one full cycle of a perfect square wave.) The 'scope is then connected to the output of the amplifier under test so that the modified square wave can be viewed on the screen. Possible output wave shapes are shown in Fig. 5b to 5i, and the significance of each wave shape is explained below.

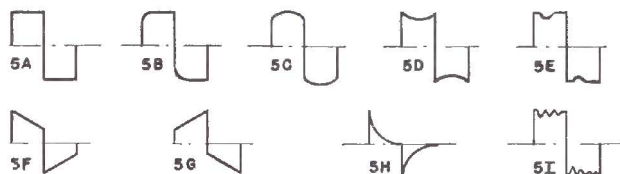

FIG. 5

Fig. 5b shows "rounding" of the leading edge of the square wave. This indicates a drop off in gain at high frequencies. "Rounding" will generally be observable when there is a substantial drop in the gain by the tenth harmonic (or less). Therefore, if a 2 kHz square wave fed to the amplifier is reproduced on the 'scope without "rounding," the amplifier is flat to $10 \times 2 \text{ kHz} = 20 \text{ kHz}$.

Fig. 5c shows the effect of increased gain and Fig. 5d shows the effect of decreased gain at the square wave frequency. Fig. 5e indicates lowered gain at a narrow frequency band. If the square wave frequency is brought into this narrow frequency band, Fig. 5d will result.

The effect of phase shift in the amplifier is shown in Figs. 5f and 5g. If, at low frequencies, there is phase shift in the leading direction, the square wave will be tilted as in Fig. 5f. If there is phase shift in the lagging direction, the top of the square wave will be tilted as in Fig. 5g. The steepness of the tilt is proportional to the amount of phase shift. Phase shift is not important in audio amplifiers, although the ear is not entirely insensitive to it. In television and 'scope amplifiers, however, phase shift should not be tolerated.

Fig. 5h shows the pulse output from the amplifier that results when the square wave has undergone differentiation. This will happen when the grid resistor or the coupling condenser is too low in value or if the coupling condenser is partially open. Lastly, Fig. 5i, shows a square wave with damped oscillations following the leading edge. This results when a high frequency square wave is fed to an amplifier in which distributed capacities and lead inductances resonate at low frequencies. In television and 'scope amplifiers it may result from an undamped peaking coil.

Audio Amplifier Response: The set up for determining the frequency response of an audio amplifier is shown in Fig. 6.

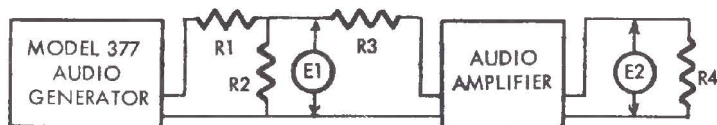

FIG. 6

The voltage dividing network R1 and R2, is necessary when testing high gain amplifiers (see "OUTPUT" in OPERATING INSTRUCTIONS). For testing low gain amplifiers, connect the output of the Audio Generator directly to the amplifier input. The resistor R3 is in the circuit only when the input of the amplifier is a transformer, and the voltage dividing network is being used. The value of R3 should be equal to the input impedance of the amplifier.

The input voltage to the amplifier is E1. If the amplifier has a high input impedance and the resistances in the dividing network are known accurately, E1 may be determined by measuring the output voltage of the generator and multiplying it by $R2/(R1 + R2)$. This may be necessary when testing high gain amplifiers where the input voltages to the amplifier are very low and therefore difficult to measure.

The output of the amplifier should be fed to a load resistor of proper value, or to the speaker or other suitable apparatus. The output voltage is measured across the load resistor R4 or other suitable load.

The amplifier gain at any frequency is equal to the output voltage, E2, divided by the input voltage, E1. To obtain the data for a frequency response curve, measure the gain of the amplifier throughout the audio frequency range.

Overall Receiver Fidelity Measurement: The set up for determining the overall fidelity of a radio receiver is shown in Fig. 7.



FIG. 7

The Model 377 Audio Generator is used to modulate the output of an R-F Signal Generator that is connected to the antenna and ground terminals of the radio receiver under test. The output voltage of the Audio Generator should be adjusted to produce about 30% modulation of the r-f signal.

Connect a voltmeter across the voice coil of the speaker. Set the R-F Signal Generator at 1000 kHz or to the desired frequency in the broadcast band, and then carefully tune the receiver to this frequency. Make sure that the receiver is exactly on resonance with the R-F Signal Generator frequency and not on one of the sideband peaks. Note that the output meter will show a maximum reading when the receiver is tuned to either of the sideband peaks on both sides of exact resonance. The receiver is tuned correctly when it is set at the point between the two sideband peaks where the output meter reading is a minimum. Data for an overall fidelity curve is obtained by recording the output voltage, E2, as the frequency of the Audio Generator is varied throughout the audio range (voltage E1 is kept constant).

CIRCUIT DESCRIPTION

General: (See Fig. 8) The Model 377 Audio Sine and Square Wave Generator is a vacuum-tube oscillator of the resistance-capacitance type. It consists of a two tube oscillator that oscillates at the resonant frequency of the Wien Bridge frequency determining network inserted in the feed-back path. The oscillator is coupled to a cathode follower amplifier that acts as an isolation stage and as a power amplifier. The square wave is formed by a dual-triode clipping circuit that is inserted between the oscillator and the cathode follower stage when square wave output is desired.

The Oscillator Circuit: (See Fig. 9) The oscillator section is basically a two tube amplifier with a Wien Bridge inserted in the feed-back path. It oscillates as a result of part of the output voltage being fed back to the input with the correct phase relation. This type of feed-back is known as positive feed-back. Negative feed-back is also employed to stabilize the oscillator operation and to maintain constant output over a wide frequency range.

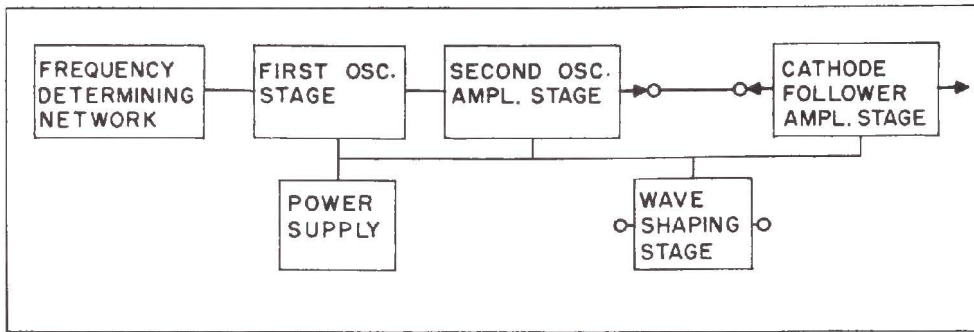

FIG. 8

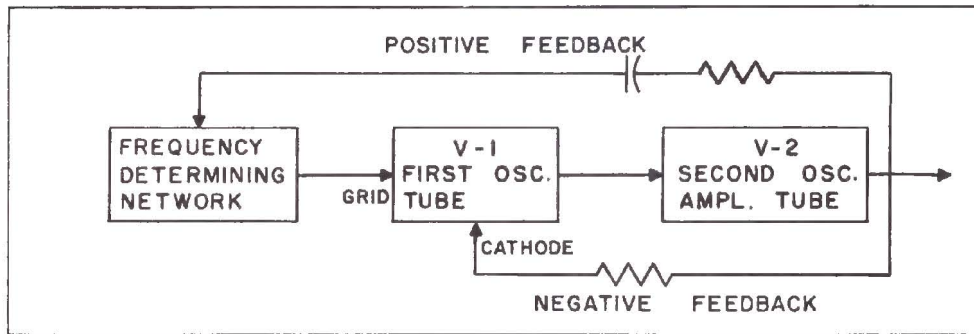

FIG. 9

The Frequency Determining Network: (See Figs. 10 and 11) The frequency determining network consists of two groups of variable capacitors and two groups of resistors wired to the band switch. Designating the resistor group R1-4 as R-S (in series with the associated variable capacitor) and R5-8 as R-P (in parallel with the associated variable capacitor), the values of R-S and R-P are fixed for each band. R-S and R-P are always equal in value, as are C-S and C-P.

The circuit design is such that the voltage applied to the first oscillator control grid is in phase with the voltage applied to the whole frequency determining network. In addition, the grid voltage is always one third of the voltage applied to the whole network. This is a characteristic of the Wien Bridge at resonance.

The resonant frequency of the network is inversely proportional to the product of resistance and capacity (R-S and C-S, or R-P and C-P). Large changes in resonant frequency are possible with each set of components. A frequency change of more than ten to one is achieved with each set of resistors, and the audio and supersonic spectrum is covered in only four bands.

Negative Feed-back and Automatic Amplitude Limiter: As may be seen in Fig. 12, the negative feedback voltage used in the oscillator section is derived from the output of the second oscillator tube, V2, and is fed back to the cathode of the first oscillator tube, V1. The magnitude of the negative feedback is determined by a resistor network, one element of which is the incandescent lamp, I2. A property of this lamp is that it has a positive temperature coefficient; however it possesses sufficient thermal inertia so that its temperature is substantially constant at all audio frequencies. Because of the lamp's positive temperature coefficient, the oscillations can not build up to a value in excess of the tube's handling capacity. This is so because the resistance of the lamp increases with increased current. As a result the degeneration in the cathode circuit of V1 increases, causing less amplification in the oscillator section. Thus, the lamp serves as an automatic amplitude limiter. Pot R9 is set at calibration for the proper negative feedback.

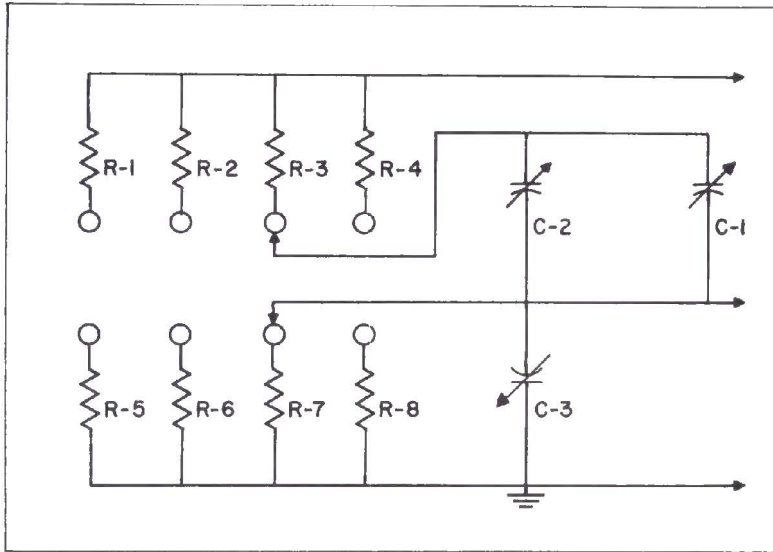

FIG. 10

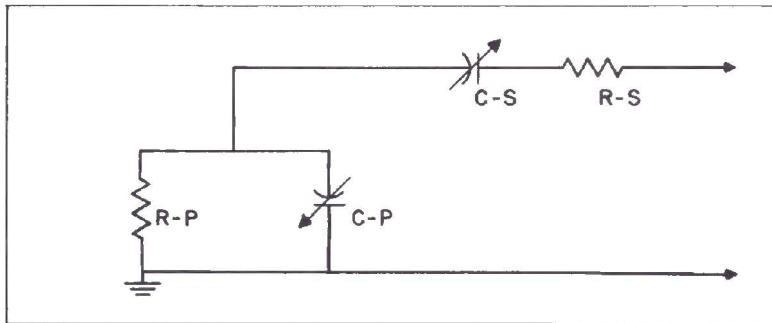

FIG. 11

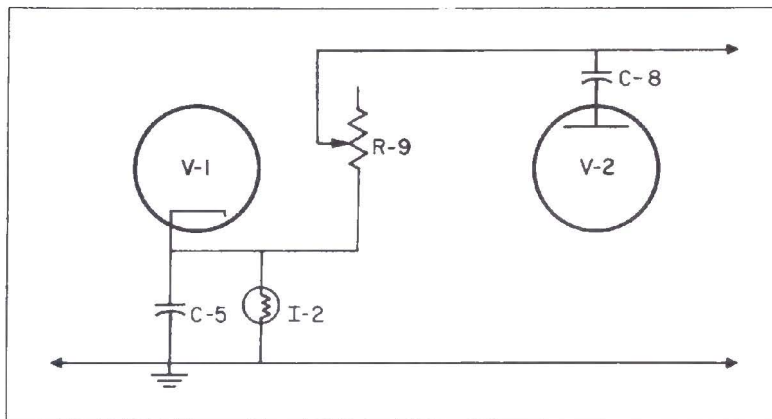

FIG. 12

The Square Wave Shaping Circuit: (See Fig. 13) The square wave is formed from the sine wave output of the oscillator section. The sine wave is fed to the grid circuit of V3 (left-half), where grid limiting occurs. This is due to the flow of grid current through R19 on the positive half-cycles, causing a voltage drop across R19 opposing the original signal voltage. As this opposing voltage increases with increasing positive signal, clipping occurs and the waveform at the grid is as shown. While the grid waveform is independent of cathode-plate conduction through the tube, the plate waveform is not. As the grid voltage dips below the cut-off point on the negative half-cycles, cut-off limiting occurs and the negative half of the plate waveform is flattened. The right half of V3 follows the plate of the left half. In this section, the rounded bottom of the wave is clipped, and the resulting square wave amplified. The squareness of the wave is increased in both sections of the tube due to the non-linear tube characteristic.

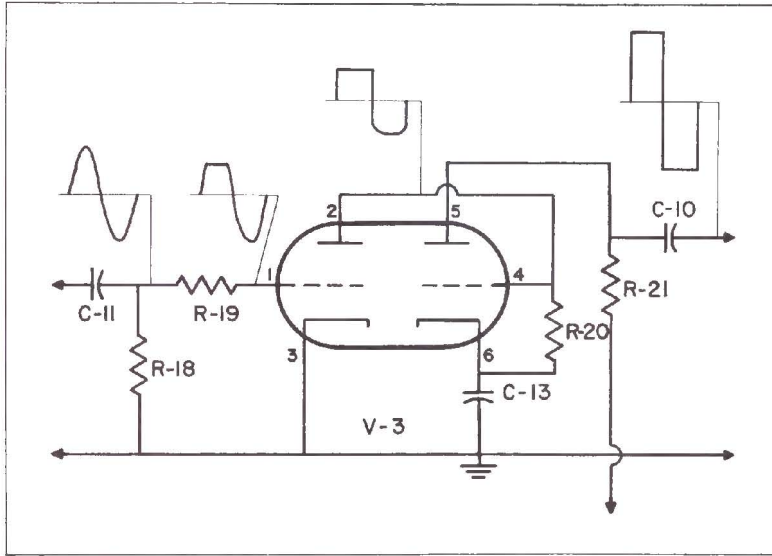

FIG. 13

The Cathode Follower Output Circuit: (See Fig. 14) in this circuit, the voltage applied to the grid of tube, V4, varies the current through the tube, which in turn varies the voltage across the total cathode resistor (R24 and R25). The output voltage is taken out through the large capacitor, C14, which presents a very low impedance over the entire frequency spectrum. The cathode resistance is split into R24 and R25 to provide the proper bias.

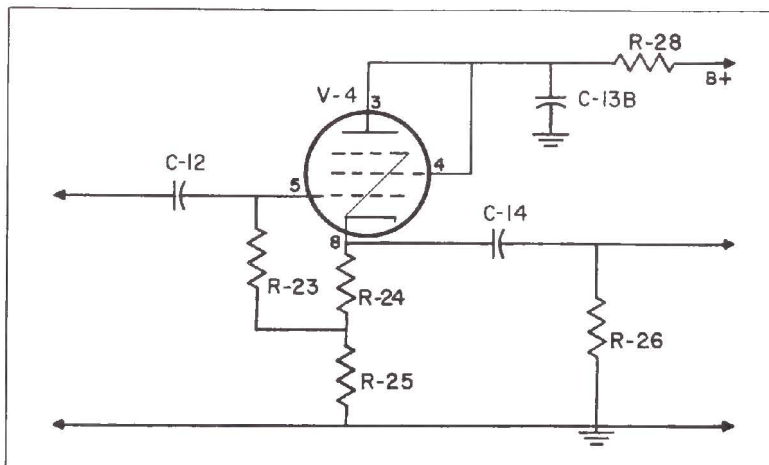

FIG. 14

The Power Supply: The power supply is a conventional full-wave rectifier circuit, employing two 800 PIV silicon rectifiers and a pi filter consisting of a choke, L1, and two electrolytic capacitors, C15 and C4B. This LC network effectively filters the d-c voltage output of the rectifier. The B+ voltages for the first oscillator tube, V1, and the cathode follower tube, V4, are additionally filtered by RC circuits. R27 and C4A form an RC filter for V1, and R28 and C13B form an RC filter for V4.

MAINTENANCE

Calibration: The Model 377 is extremely stable. However, after a long period of use, it may require recalibration due to aging of the components. The accuracy may be readily restored by using one of the methods below. Recalibration will also be necessary whenever tubes or other components are replaced. Fig. 15 shows the locations of trimmer C1, pot R9, and the tubes.

The A-C Voltmeter method is satisfactory for general use of the instrument. The Oscilloscope method is preferable, however, as it gives better accuracy. The Frequency Standard method is necessary for work that requires very accurate knowledge of the frequency.

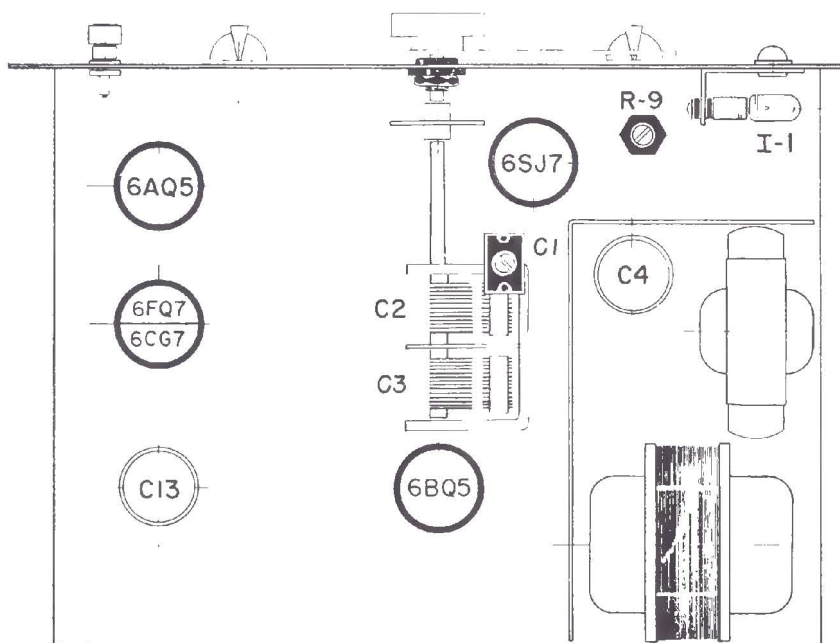

FIG. 15

1. **A-C Voltmeter Method:** This method requires only an a-c voltmeter, preferably one with 1000 ohms/volt sensitivity or more. The procedure is as follows:

- a. Connect a 1000-ohm resistor across the output terminals of the Audio Generator.
- b. Connect the a-c voltmeter across the resistor.
- c. Set the BAND switch at band B and the frequency dial at 200 Hz.
- d. Turn the AMPL. control to the maximum clockwise position.
- e. Adjust pot R9 for a reading between 10.5 and 11 volts (r. m. s.) on the meter.
- f. Turn the frequency dial knob to 2 kHz.
- g. Loosen or tighten the adjustment screw on trimmer C1 with an insulated alignment tool until the voltage read on the meter is equal to the voltage read when the frequency dial knob was set at 200 Hz.

The instrument is now calibrated. As a check, turn the frequency dial knob back to 200 Hz, observing the meter as you do so. The voltage should be nearly constant over the entire frequency range.

2. Oscilloscope Method: This method requires an oscilloscope with a 60-Hz test output and an a-c voltmeter. The procedure is as follows:

- a. Adjust pot R9 as described in steps a, b, c, d, and e of the A-C Voltmeter method.
- b. After pot R9 has been adjusted for a reading between 10 and 11 volts, disconnect the a-c voltmeter (leaving the 1000-ohm resistor).
- c. Connect the output of the Audio Generator to the vertical input terminals of the 'scope.
- d. Connect the 60-Hz test terminals of the 'scope to the horizontal input terminals.
- e. Set the BAND switch of the Audio Generator at band A, and turn the frequency dial knob to 180 Hz.
- f. Adjust the 'scope controls for roughly equal deflections on each axis.
- g. Loosen or tighten the adjustment screw on trimmer C1 with an insulated alignment tool until the Lissajous figure shown in Fig. 3b (for 3:1 ratio) appears stationary on the screen.

The instrument is now calibrated. As a check, turn the frequency dial knob to 20 Hz. The Lissajous pattern shown in Fig. 3e should appear on the screen. Turn the frequency dial knob to 60 Hz. One of the Lissajous patterns shown in Fig. 2 (for 1:1 ratio) should be obtained.

3. Frequency Standard Method: This method requires either a standard audio generator with known accuracy or a fixed frequency standard. Before calibration, allow the Model 377 to heat up for at least thirty minutes. The calibration procedure is the same as described in the OSCILLOSCOPE method above. Instead of the 60-Hz test signal, however, the standard is connected to the horizontal input of the 'scope.

If a standard generator is used, set it at a frequency of 2 kHz. Set the BAND switch of the Model 377 at band B, and the frequency dial knob at 2 kHz. Adjust the trimmer, C1, until one of the Lissajous patterns shown in Fig. 2 (for 1:1 ratio) appears stationary on the screen. The Model 377 is now calibrated. As a check, adjust the standard generator and the Model 377 to equal frequencies on their respective dials at two other points in band B and three points in each of the remaining bands. One of the Lissajous figures for 1:1 ratio should appear on the screen at each point, allowing for the specified accuracy of Model 377.

If a fixed frequency standard is used, set the Model 377 at a nominal frequency near the high end of band B that is in the ratio of a whole number or a simple fraction to the fixed standard frequency. Adjust the trimmer, C1, until the appropriate Lissajous figure appears stationary on the screen. The instrument is now calibrated. Check at least two other points on band B and three other points on each of the remaining bands by means of the appropriate Lissajous figures.

Lamp Replacement: The three watt lamp, I2, is never lit up in normal operation as it is operated below the level necessary for incandescence. As a result, it should have extremely long life. If, however, it becomes necessary to replace the lamp, it is required to check the a-c voltage from the arm of R9 to ground with the new lamp in place. This a-c voltage should be between 15 and 20 volts (r. m. s.), as measured with a high impedance vacuum-tube voltmeter, when the Audio Generator is tuned to 1000 Hz. If the voltage is not within this range, correct it by adjustment of pot R9. If the voltage cannot be brought within 15 to 20 volts with the new lamp in place, try another lamp instead.

Intermittent Output: If the output is intermittent, check to see if the three watt lamp, B1, is flashing also. If it is, check for a short in the main tuning condenser. Clear out the short, but be careful not to bend the plates.

Distortion: Excessive distortion may result from a bad tube, a leaky coupling capacitor, an open by-pass capacitor, a defective electrolytic capacitor, low B- voltage, or too much output from the oscillator section of the circuit.

PARTS LIST

PRICE EA.	STOCK NO.	SYM. NO.	DESCRIPTION	QTY	PRICE EA.	STOCK NO.	SYM. NO.	DESCRIPTION	QTY
RESISTORS					HARDWARE (cont.)				
.05	10016	R26, 27	10K, 1/2W, 20%	2	.01	42081		washer, flat, plastic, red	1
.05	10022	R10	47K, 1/2W, 20%	1	.03	43000		lug, ground, #6	3
.04	10023	R12	68K, 1/2W, 20%	1	.03	43001		lug, pot., ground, 3/8	1
.05	10028	R13, 18, 19	470K, 1/2W, 20%	3	.03	43019		lug, ground, #8	2
.05	10030	R23	1M, 1/2W, 20%	1	.11	44011		spacer	3
.04	10038	R20	3.3K, 1/2W, 20%	1	.08	45500		spade bolt, #6-32 X 1/2	3
.04	10042	R29	330Ω, 1/2W, 20%	1	.05	46000		grommet, rubber, 3/8	4
.13	10771	R14	820Ω, 1W, 5%	1	BINDING POSTS, KNOBS, & TERMINAL STRIPS				
.14	10811	R11	100K, 1W, 20%	1	.56	52001	J2	binding post, #8, 5 Way, black	1
.14	10819	R21	15K, 1W, 20%	1	.56	52002	J1	binding post, #8, 5 Way, red	1
.12	10862	R24	330Ω, 1W, 10%	1	.38	53006		knob, round, bar	2
.08	10865	R30	100Ω, 1W, 10%	1	2.24	53500		knob, w/pointer	1
.28	10902	R28	1K, 2W, 20%	1	.05	54001		terminal strip, 1 post, right	1
.28	10904	R16	10K, 2W, 20%	1	.06	54019		terminal strip, 2 post, right	1
.28	10906	R17	33K, 2W, 20%	1	.11	54055		terminal strip, 5 post, 3 left	1
.43	11053	R2, 6	1.8M, 1/2W, 1%	2	.09	54085		terminal strip, 3 post, 2 right	1
.43	11054	R3, 7	180K, 1/2W, 1%	2	.10	54097		terminal strip, 4 post, w/gnd	1
.43	11055	R4, 8	18K, 1/2W, 1%	2	SWITCHES				
1.32	11702	R1, 5	18M, 1W, 1%	2	2.30	60016	S2	rotary, 2P4P	1
.39	14300	R15	10K, 10W, 10%	1	1.63	61000	S1	toggle, SPST	1
.33	14502	R25	1.8K, 5W, 10%	1	.48	62000	S3	slide, DPDT	1
POTENTIOMETERS					TUBES, BULBS, & DIODES				
.88	16004	R22	50K, 20%, linear	1	3.57	90006	V1	tube 6SJ7	1
.89	18009	R9	5K, 20%, linear	1	2.41	90047	V4	tube 6AQ5A	1
CAPACITORS					2.01	90097	V3	tube 6FQ7/6CG7	1
.33	20019	C7	mylar, .0033 mfd, 600V, 10%	1	3.04	90107	V2	tube 6BQ5	1
.32	20046	C6	molded, .47 mfd, 20%	1	.24	92000	I1	bulb, #47	1
.52	20085	C11, 12	mylar, .22 mfd, 10%	2	1.35	92001	I2	bulb, 3S6-3W	1
.33	21001	C9	mica, 270 pf, 500V, 20%	1	.36	93006	D1, 2	diode, 800 PIV, 500 mA	2
.30	22000	C5	cer., 50 pf, 20%, NPO	1	SOCKETS AND PILOT LIGHT ASSEMBLIES				
.80	23002	C8, 10	elec., 8 mfd, 350V	2	.31	97003	XV1	socket, octal, molded	1
.72	23004	C14	elec., 20 mfd, 150V	1	.18	97024	XV4	socket, 7 pin, min., black	1
1.56	23005	C15	elec., 8 mfd, 450V	1	.20	97025	XV2, 3	socket, 9 pin, min., black	2
2.64	24001	C4, 13	can., 2 X 20 mfd.	2	1.21	97700		pilot light assembly	1
4.93	29035	C2, 3	var., air, 2 X 420 pf.	1	.52	97705		pilot light assembly 3S6 bracket	1
.59	29507	C1	var., trim, 5-80 pf.	1	SHEET METAL & MISCELLANEOUS				
TRANSFORMERS					.90	57004		linecord	1
8.95	30002	T1	power	1	1.50	66244		manual, instruction	1
3.13	34000	L1	choke, 5 Hy	1	2.00	66245		manual, assembly	1
HARDWARE					5.93	80040		front panel	1
.01	40000		nut, hex, #6-32 X 1/4	15	2.01	81013		shield	1
.02	40001		nut, hex, 3/8-32 X 1/2	4	3.25	81699		chassis	1
.09	40002		nut, hex, 15/32 -32 X 9/16	1	.40	82000		shaft, 1/4 dia.	1
.01	40003		nut, ring, 15/32-32	1	2.59	83000		insulated coupling	1
.01	40007		nut, hex, #4-40 X 1/4	12	.45	85000		bushing, 3/8"	1
.01	40008		nut, hex, #8-32 X 1/4	4	.25	85544		label, tube layout	1
.05	40034		nut, tinnerman, #4	2	1.09	87000		handle, metal	1
.01	41006		screw, #10-24 X 3/8, b.h.	2	6.75	88002		cabinet	1
.01	41010		screw, #6-32 X 1/8, b.h.	1	Prices and specifications subject to change without notice. To order replacement parts, remit with order; specify part number and description. Add \$1.00 for mailing and handling; if a power transformer is included in the order, add \$1.50 for mailing and handling.				
.01	41016		screw, #4-40 X 1/4, b.h.	12					
.01	41035		screw, #6 X 1/4, p.k., b.h.	9					
.01	41084		screw, #6-32 X 5/16, b.h.	12					
.01	41130		screw, #6-32 X 7/8, b.h.	3					
.01	41143		screw, #4-40 X 3/8, f.h.	2					
.01	42000		washer, lock 3/8	4					
.01	42001		washer, flat 3/8	2					
.01	42002		washer, lock, #6	15					
.01	42007		washer, lock, #4	12					
.04	42034		washer, flat, #6, low loss phenolic	3					
.03	42035		washer, shoulder, #6, low loss phenolic	3					
.07	42043		washer, shoulder, plastic, black	1					
.04	42045		washer, flat, metal, 5" TK	1					
.01	42046		washer, flat, metal, #8 X 3/8, O.D.	2					
.01	42080		washer, shoulder, plastic, red	1					

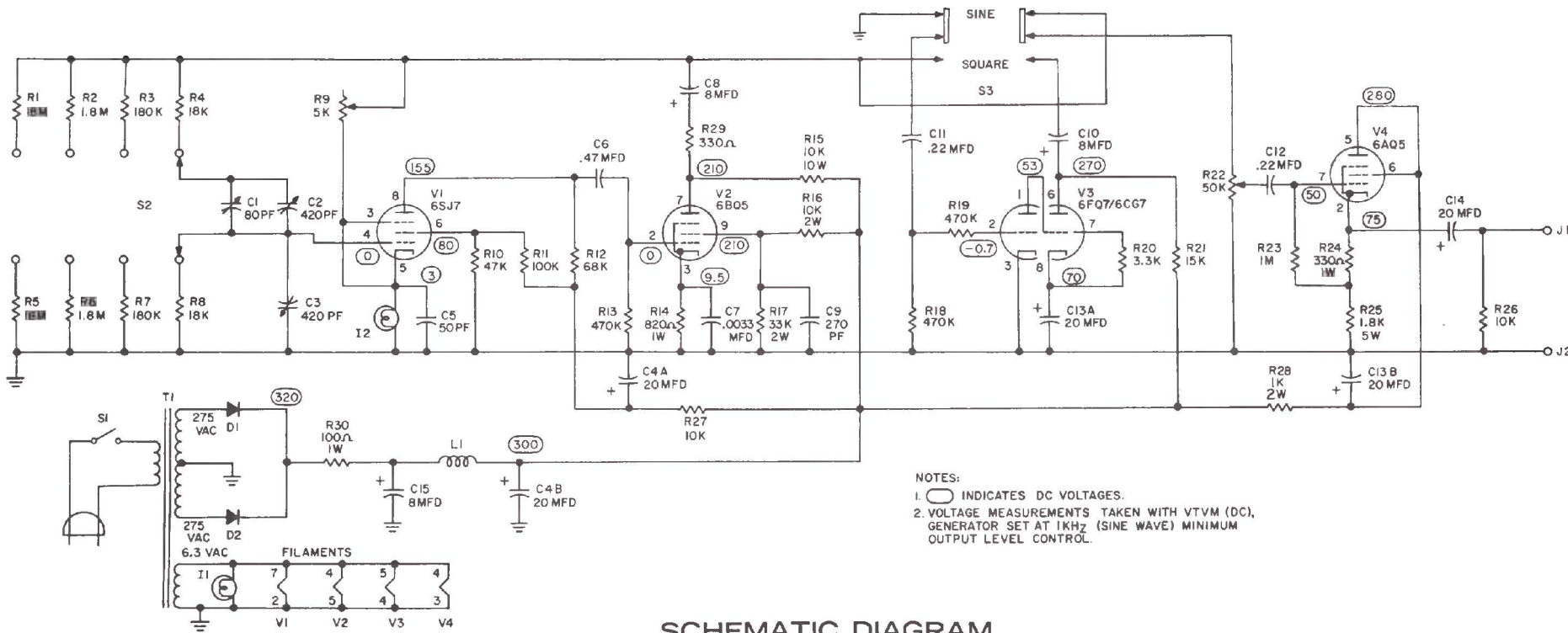

- NOTES:
 1. ○ INDICATES DC VOLTAGES.
 2. VOLTAGE MEASUREMENTS TAKEN WITH VTVM (DC), GENERATOR SET AT 1KHz (SINE WAVE) MINIMUM OUTPUT LEVEL CONTROL.

SCHMATIC DIAGRAM

EICO 377

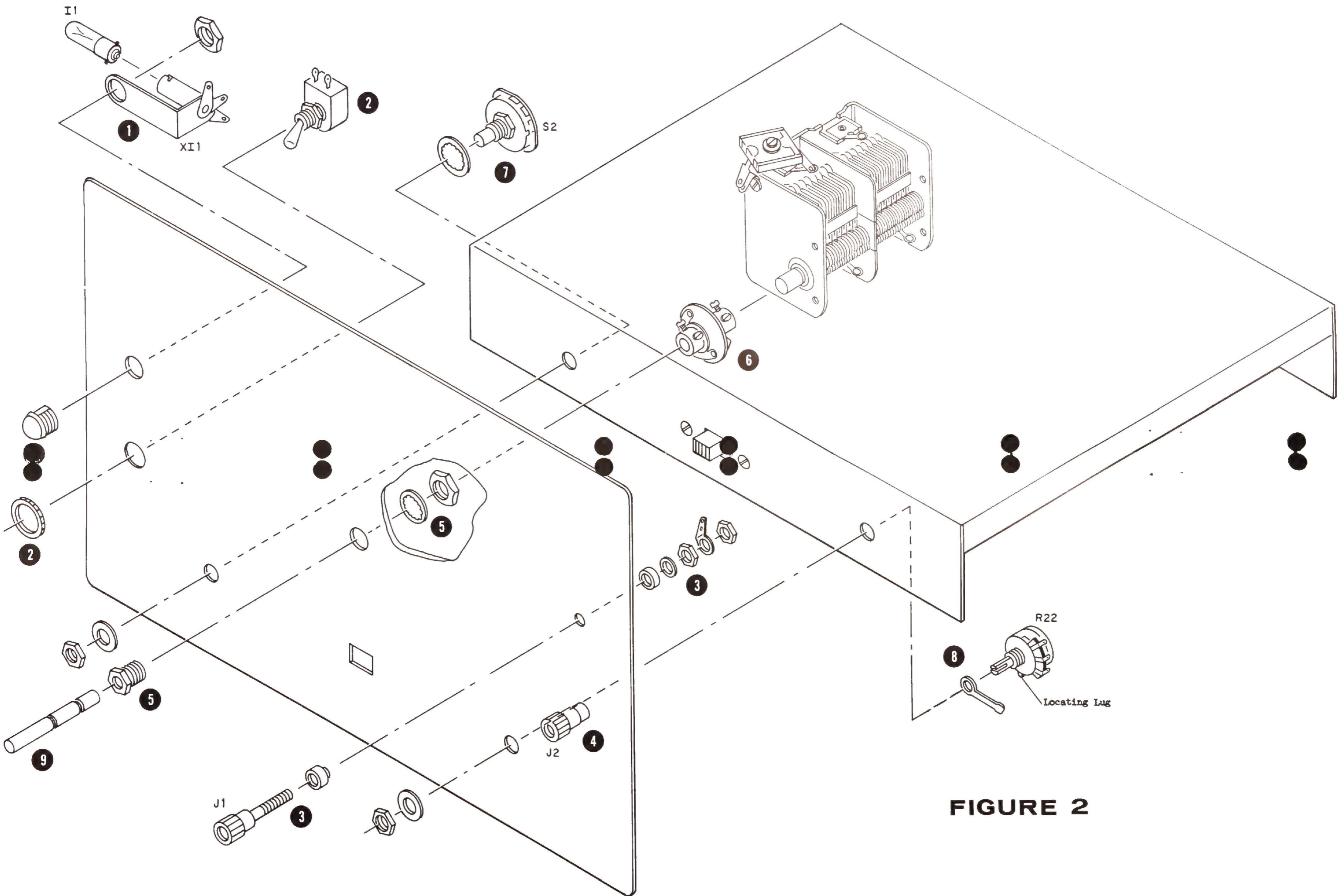

FIGURE 2

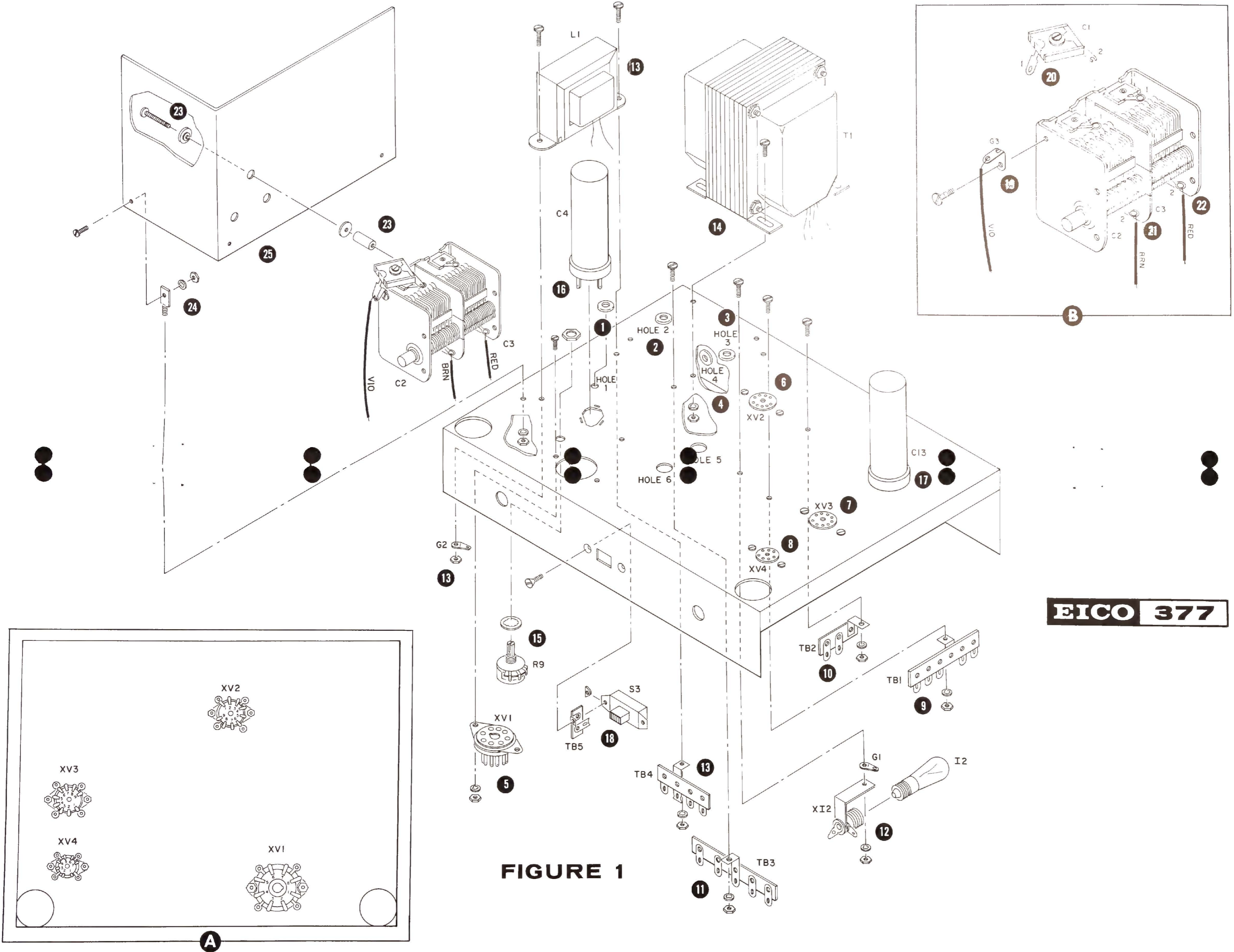

FIGURE 1

EICO 377

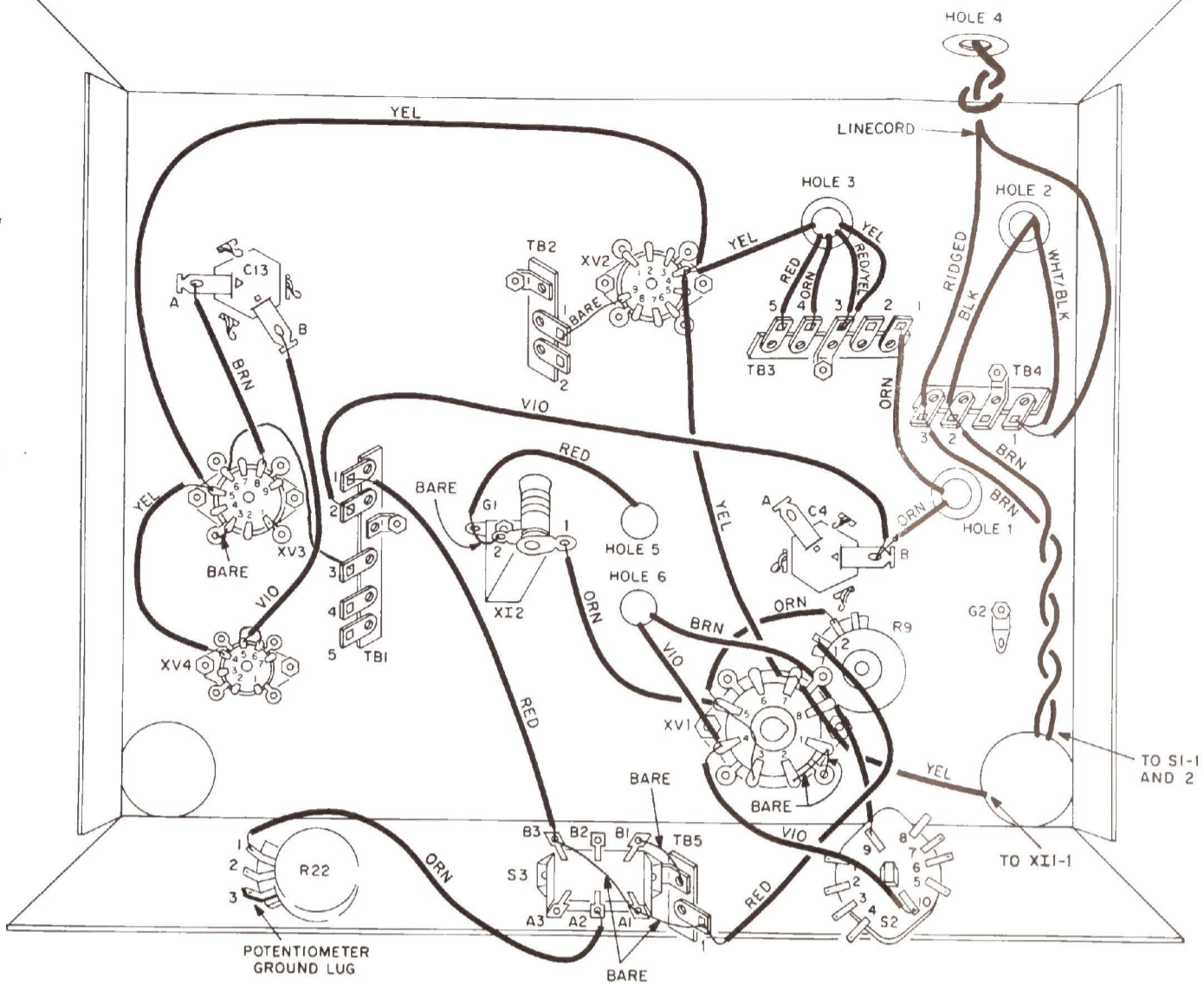
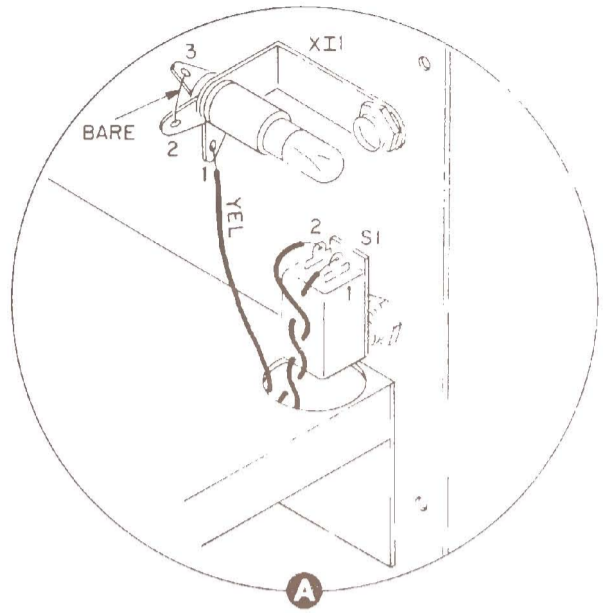

FIGURE 3A



EICO 377

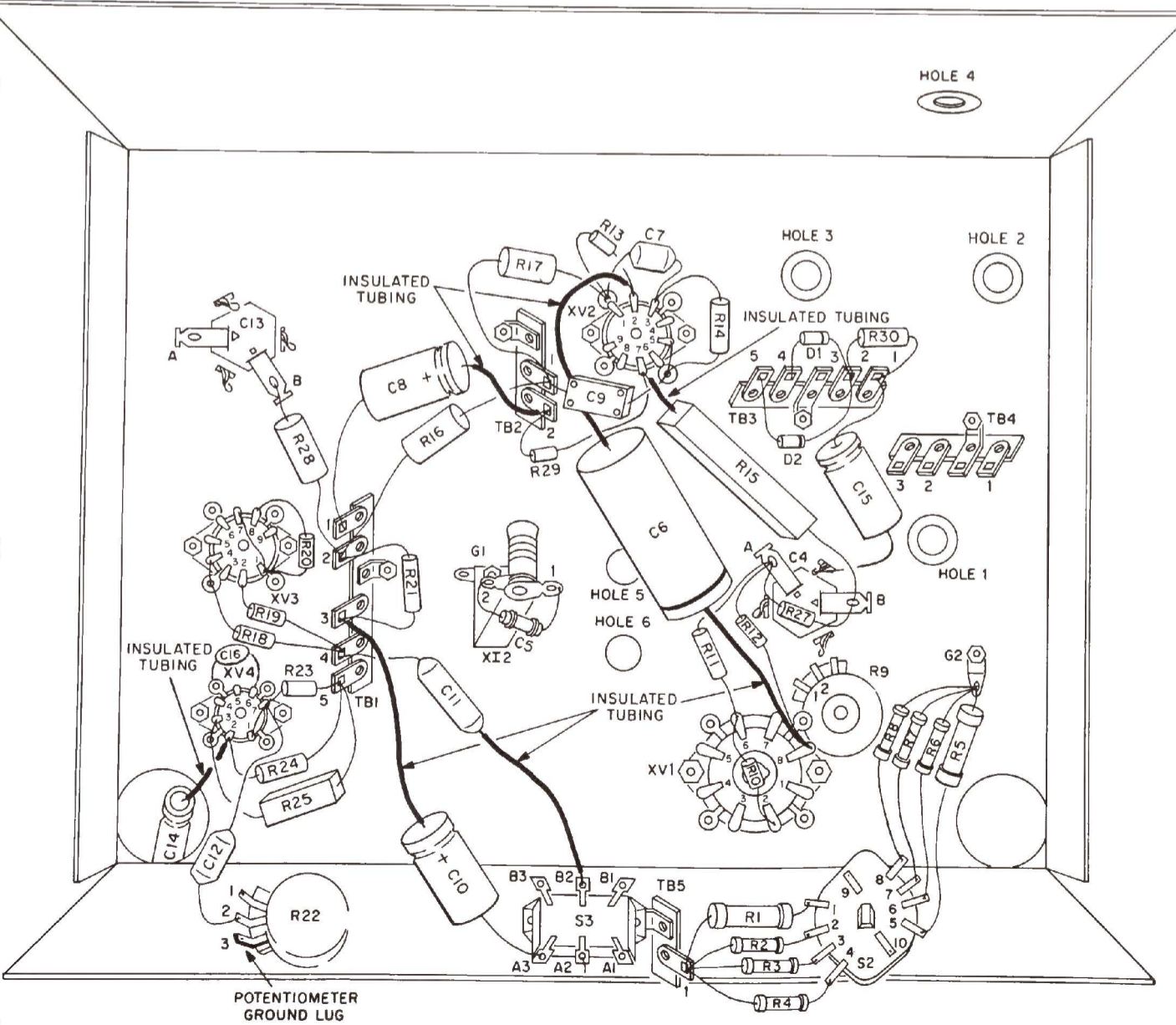
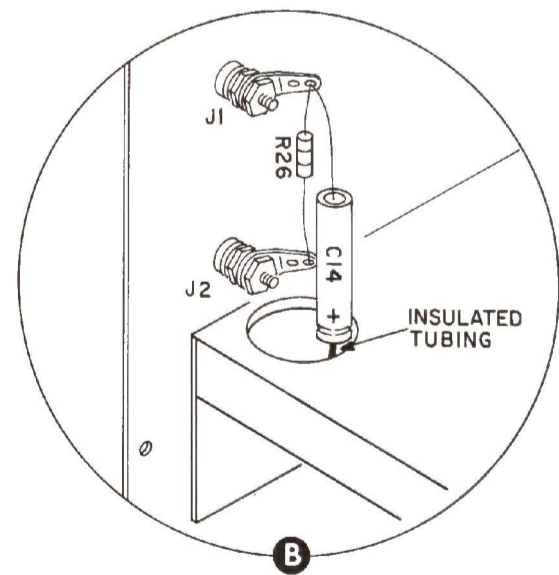

FIGURE 3B



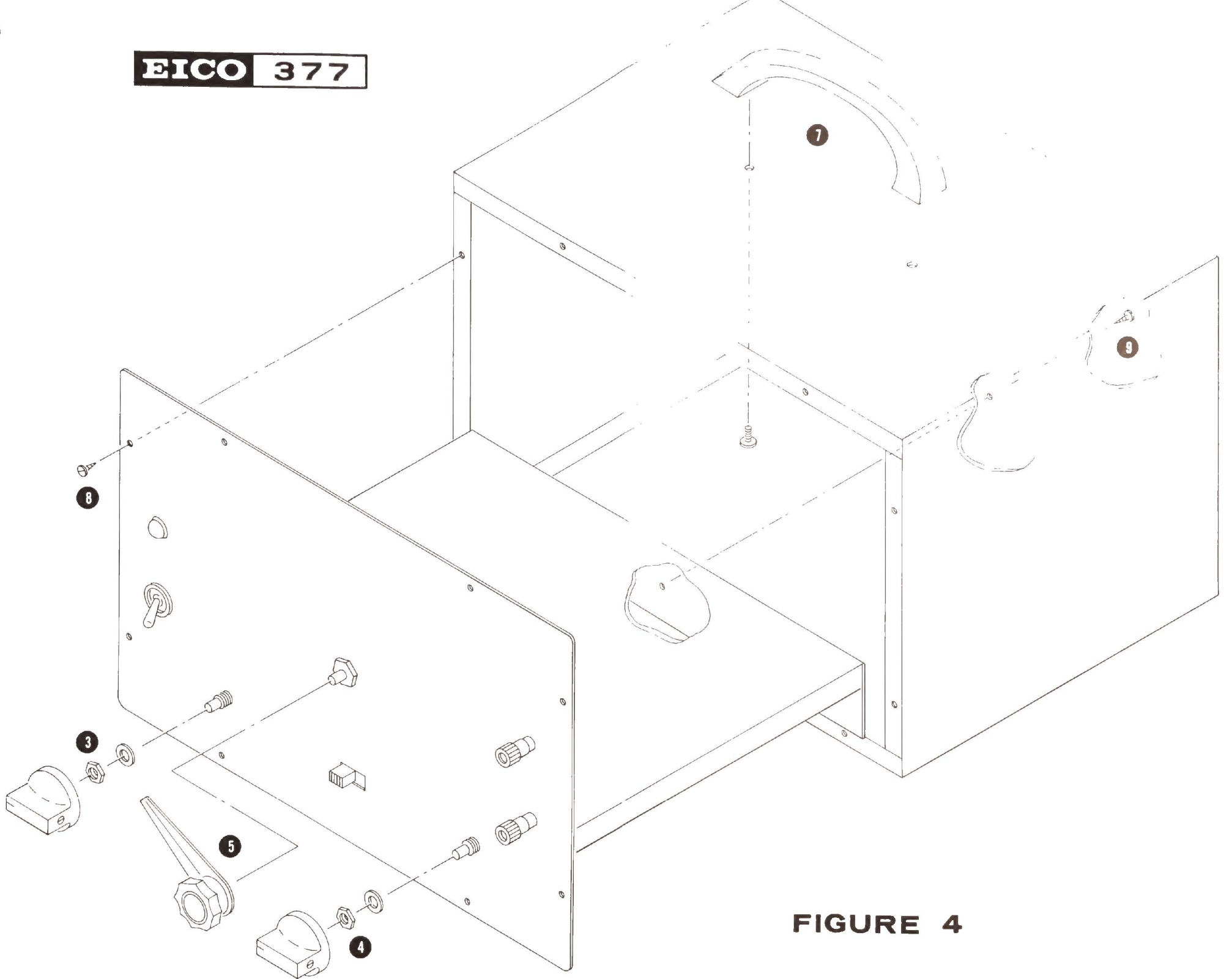
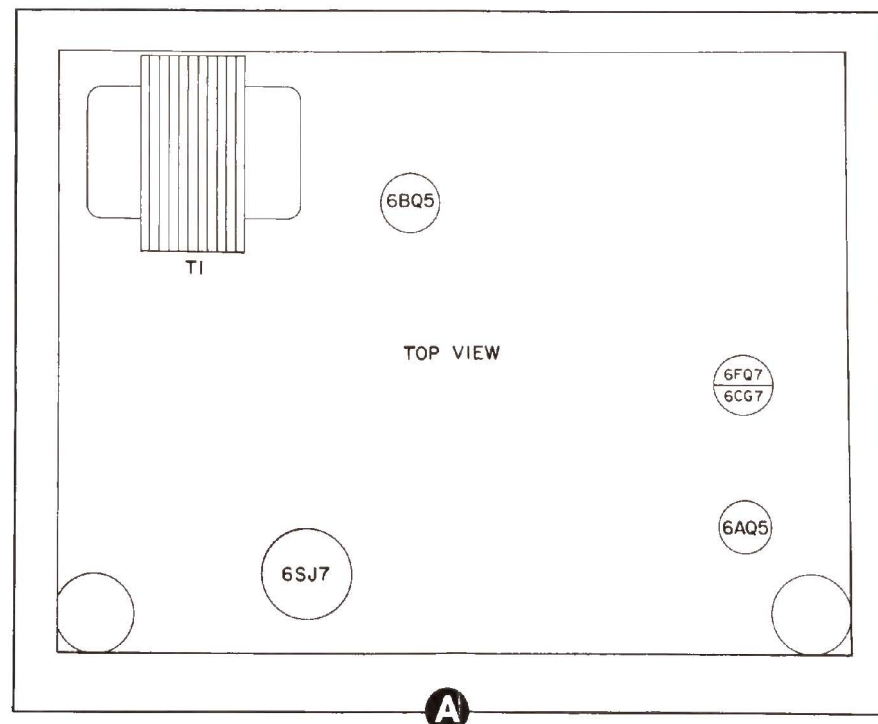

FIGURE 4



66244

EICO—LEADER IN CREATIVE ELECTRONICS

For over 23 years, EICO has been designing and manufacturing electronic products and is now the world's largest producer of electronic kits and factory wired equipment marketed exclusively through dealers and distributors throughout the world.

Whatever your electronics interest, there's a wide range of versatile, professional EICO products for you to choose from, and each designed to provide you with the most pleasure and quality performance for your money.

The fact that more than 3 million EICO products are in use throughout the world attests to their quality and performance. EICO kits are so popular because they represent the best value and are available for inspection and immediate over-the-counter delivery at more than 2500 EICO dealers and distributors.

Should you have any questions about the selection or applications of any EICO product, you may at any time consult by mail with our technical correspondence staff. There's no charge for this service.

For your added convenience — EICO has set up a network of 200 service stations to make available to you on a local neighborhood basis the same high-quality technical service competence and replacement parts you get from our factory, should you ever need them.

The EICO Catalog is available to you Free for the asking. The catalog describes Eico's complete line of 200 "Best Buys" in Electronics. Cortina® Stereo Components, EICOCRAFT® Solid State electronic projects, Citizens Band 2-Way Radios, Automotive electronics, Amateur Radio equipment, Visutronic® Educational Training Aids, TRUVOHM® professional Multimeters and the famous EICO line of Test Instruments for home, shop, factory, laboratory and school.

www.manualsplus.com



1024409

