

QRP Automatic Antenna Tuner

Assembly Manual Ver 2.0c

LDG Electronics

1445 Parran Road St. Leonard MD 20685

Phone: 410-586-2177 Fax: 410-586-8475

e-mail: ldg@radix.net

<http://www.radix.net/~ldg>

Introduction: The QRP autotuner is a full featured auto or semi automatic antenna tuner designed for HF (1.8 to 30 MHz) transmitters using 0.1 to 10 watts. It was modeled after the AT-11, a 100 watt version of the auto tuner that first appeared in the January 96 issue of QST magazine. Both tuners use a switched "L" configuration with 256 capacitor, 256 inductor and Hi/Lo-Z settings to provide over 131,000 tuning combinations (figure 1) (figures appear at the end of text). The "L" network works great with just about any coax fed antenna (dipole, vertical, beam, ect). It can be optimized to work with balanced line fed antennas (and random wires) with a 4 to 1 or 6 to 1 balun (not provided). Tuning time of the QRP version has been improved to between 0.1 and 3.0 seconds with an average time of 1.5 seconds.

Operation of the tuner is auto or semi automatic. In auto mode, the tuner will seek a 1.5 match anytime the SWR is above 3.0. In semi mode (semi line is grounded), the tuner will only seek a match when the tune input line is grounded. Both modes require that more than 0.1 watts of RF power be present. Up and down input lines are provided for fine tuning the inductors and capacitors and can be used in either mode.

Four outputs to LEDs provide an indication of SWR and status. Green indicates SWR of less than 1.5, Green/Yellow is 1.5-2.0, Yellow is 2.0-2.5, Yellow/Red is 2.5-3.0 and Red indicates more than 3.0. The fourth LED is a tuning indicator. It is lit when the tuner is trying to find a match.

Building the Kit: The QRP autotuner is a small sized project. It should take the average builder an evening or two to complete. We averaged 2 hours for populating the PC boards for the prototypes, but it may take another hour or two to install it inside your favorite transmitter or enclosure. Besides the normal building tools needed (small soldering iron or soldering pencil, wire cutters, screwdriver, ect), the only test equipment needed is an HF transceiver, dummy load (or resonant antenna) and voltmeter.

Just about anything that the PC board will fit into will work as an enclosure. A metal enclosure is not a requirement, it can be plastic. LDG has a package that includes a custom enclosure made by Ten-Tec Inc and all front and back panel hardware (SO-239 connectors, switches, LEDs) for \$25 plus \$6 shipping.

Kit Assembly: Before starting, you may want to get a copy of the QST article where the original AT-11 first appeared. Although not needed for construction of the QRP kit, it contains a little more theory about the AT-11 along with some pictures. If you don't have or can't find the article, a reprint may be available from

QST, 225 Main St., Newington CT 06111. We've included the charts and tables from the article (modified for the QRP version) needed to build the kit in this manual.

Before getting the soldering iron out, go through all of the parts in the kit and familiarize yourself with each component and its placement. Most of the parts are common, but a few of them may be new to some builders. There are about 150 parts and 500 solder connections, so take your time.

Once familiar with the parts, start with the nine T-50 toroids (they are red and just over a half inch in diameter). Take care to not drop them, they will break. Use the number #24 gauge wire provided to wind L1-8. For consistency, we count one turn when the wire passes through the center of the toroid. L1-4 just loop at the bottom of the toroid (figure 2). L5-8 are evenly spaced around (figure 3). L8 is a double toroid, two toroids held together with the winding around both of them. Use the inductor table to cut the wire to length (figure 4). Wind each toroid in the same direction as shown in the diagrams. Note that L1-4 wind in one direction and L5-8 wind in the other. The PC board is laid out with offset solder pads for the toroids. If you wind them backwards, the offset will not match. Trim the wire to about 1/2 inch and scrape away the insulation from the end. Don't solder them in until later.

Next, wind T1 with 10 turns (figure 5). It is the small, black toroid and just under 1/2 inch in diameter. The windings use the smaller #28 gauge wire and are made bifilar. This means to use two lengths of wire and wind them at the same time. It doesn't matter if you twist them together or just wind them side by side. Connecting Green 1 and Red 2 together forms the center tap of T1. Be sure to note that the wire on the left side comes from under T1 and the wires on the right side comes over the top side of T1. Trim the wire to about 1/2 inch and scrape away the insulation from the end. Do not install T1 until later.

Notice that some of the silk screen markings on the PC board may have been drilled away when it was fabricated. Use the Parts Placement layout in the back of this manual to assist in locating where parts are installed.

The parts are installed and soldered in order of height, from shortest to tallest. With the PC board blank, it is easiest to install all of the resistors first. Be sure to check the values with the parts list. Most of the resistors are 1/8 watt and may be hard to read. Use an ohmmeter to verify the values if you have trouble identifying them.

After the resistors are installed, install the 1N4148 diodes. Then, the larger 1N4001 (D3). Be sure to note the band polarity on both types. Next, install the groups of monolithic and ceramic caps. This includes the

tuning capacitors, C25-34. Be sure to match the values from the capacitor chart (figure 6). The SIP resistor pack can also be installed. Be sure to note the orientation of the SIP resistor (the tuner will not work if it is installed backwards). A small line (or dot) on the side with writing marks pin 1.

Next install U2, the 34064 (use the parts placement sheet for orientation). Then U3, the 78L05. Next, install Q1-17. Note the orientation. Then, the variable resistors R23 and 24. Then the Variable capacitor C1.

Now install T1. You may wish to use a small amount of silicon RTV or glue to hold T1 in place, but wait until after the unit is tested before applying it in case there are problems. T1 will lay flat against the PC board. The wire that carries the RF input from the transmitter will pass through the center of T1 and solder directly to the PC board.

Now install the socket for U1. Note the orientation of the socket. The flattened corner goes in the lower right, toward the crystal. There should also be an arrow inside the socket that will point away from the relays (see the parts placement sheet). Do not install the 68HC11 until later. Then the crystal X1. Now, relays K1-17 can be installed. Then the two electrolytic capacitors, C9 and 18, note the polarity.

Lastly, inductors L1-8 can be installed on the PC board. Note that the mounting holes are offset slightly to help keep the inductors straight after installation. The inductors can be pushed in until the windings touch the PC board. Don't forget to scrape the insulation off the ends before trying to solder. The #24 wire may be stiff enough to support L5-8, but a non-acidic RTV or hot melt glue may be needed for L1-4 to hold them in place. The RTV or hot melt glue should be used if you plan to use the unit in a mobile application.

Checkout: The circuit should be "power on" tested once all the components except for U1 (the 68HC11 chip) have been installed. Apply 12 to 14 volts DC to the power input. Check for +5.0 volts on the output of the 78L05 (pin closest to U1). Current draw should be around 2.5 mA (anything less than 10.0 mA is acceptable). If the volts and amps look good, you can proceed to mount the unit in a case or inside a transmitter and begin wiring the user interface. Use the four mounting holes provided on the PC board, do not drill the mounting holes on the PC board holes to make them larger.

J3 is laid out on the board as a 14 pin header with 0.1 inch spacing (figure 7). A header is provided for wiring to the user interface. Depending on your particular installation, you may only want to connect a single wire for the Tune button. If you desire the auto feature, you will have to either wire the Auto line to ground to enable that mode or connect that line to a toggle switch to allow selection of modes. Likewise, you may not need

the SWR or tuning indicators in your installation, but they are there if desired.

A ribbon cable is provided to make front panel connections (see figure 8 for wire assignments). Note that when plugged in, the wire should extend away from the microprocessor. The two ground wires (pin 13 and 14) should be connected to the front panel ground wire (see figure 9).

The Auto/Semi input line is ground activated. That is, when the line is grounded, it will be in the Auto mode. If it left floating, it in the semi mode. The Tune, Cap Up, Cap Dn, Ind Up, and Ind Dn are also ground activated. Grounding the line will activate it. The LED current is supplied from the processor. The flattened side (on the plastic part of the LED) should go to ground. You can see the flattened side by looking at the LED with the leads facing you. The flattened side will be right next to one of the leads. See figure 9 for details on wiring the front panel.

The typical minimum installation was envisioned to be just the Tune line run to a momentary contact push button on the front panel of your transmitter. Nearly most of the time, the up / down buttons for the fine tuning are not needed. The unit is set to find a match of less than 1.5:1 and nearly always does.

Once everything is mounted and wired, U1 (the 68HC11) can be placed into the socket and power applied. Notice that U1 has a flattened corner that should match the socket. Be careful here, it *will* go in backwards and it *will* destroy the processor if it is powered on while in the socket backwards. The writing on the chip should be upside down while looking at the board while the inductors are on the top. On power up, the unit will flash all LEDs (if used) once to indicate that everything has initialized successfully. Current draw should be around 10 to 15 mA.

Each relay draws about 12 mA when energized. If a relay energizes on power up (a sign there is a problem), you will not be able to tell (by current draw) if the processor is working properly. No relays should energize when the unit is first powered on. The maximum current draw is about 190 mA with all the relays energized. Since it is rare that all relays are energized, the average current draw is about 75 mA.

Alignment: The tuner can be powered on or off during alignment. We recommend to leave it off so that other components that could possibly have problems will not interfere. If you leave it on for testing, be sure to place the Auto/Semi switch in the Semi position. Otherwise, it will start tuning while you are adjusting. Set R23 and 24 to the center position. With a voltmeter on test point REV (marked on the silk screen) and about 5 to 10 watts applied to the input and a dummy load or resonant antenna on the output, tune C1 for minimum DC

voltage. It should dip to just about 0.0 volts. You MUST use a 50 ohm load to properly do the alignment. If the load is not resonant, you may get more than 0.0 volts on the REV test point. Anything less than 0.2 volts will provide satisfactory results.

Then, apply 5 to 10 watts to the input. Adjust R23 for 2.5 (2.3 to 2.5 is Ok) volts on test point FWD. Move the dummy load to the input and apply 5 to 10 watts to the output. Adjust R24 for 2.5 volts on test point REV. Be sure to not go over 2.5 volts on either test point.

If you don't get 5 watts out of your radio, use 2 to 3 watts and adjust for 1.5 volts for both. That's it, the tuner is now ready to be placed on the air.

Operation Notes: In general, the tuner operation is straight forward (you push the tune button and it finds a match) and works as described in the introduction section of this manual.

The software for the QRP version was modified slightly from the original AT-11 to help reduce power consumption. When the tuner is in the semi mode, the processor will go to sleep after it finds a tune. This reduces power consumption by about 20 mA once a match is found. Note that while the processor is asleep, the LEDs (if used) will also be disabled. The processor can be woke up by pressing the tune button once while no RF is present. It can also be forced to go to sleep by simultaneously pressing both down fine tune buttons (if used).

When the tuner is in the auto mode, it does not go to sleep, it stays awake to monitor for an SWR of above 3:1. Again, it can be forced to go to sleep by simultaneously pressing both down fine tune buttons (if used) and be woke up by pressing the tune button once while no RF is present.

Although specified for 10 watts, the actual maximum operating power can be as high as 30 watts (at 50% duty cycle). The relays are rated for over 30 and the toroids will handle about 50, but the RF input power should never exceed 30 watts..

If the LEDs are installed, they will indicate SWR whenever there is more than .1 watts of forward power. If you press the tune button and there is less than .1 watts of forward power, it will not go to the tune algorithm and all LEDs will flash once.

You can use SSB to provide the power for tuning. Just press your mic and say something (like "Ahhhhhh") until the unit stops tuning (somewhere between .1 and 3 seconds). If the tuner has a hard time finding a match or doesn't find 1.5, try using a CW or AM carrier.

If you reach the upper or lower limit of the inductors or capacitors with the manual fine tune push buttons, the LEDs will flash while the button is pressed.

When in the auto mode, if the tuner can not find a better than 3.0 to 1 match, the tuning algorithm will be repeated until power (either RF or +12) is removed or the mode switch is placed in the semi position.

In either mode, if RF power is removed after the tuning cycle starts, but before it finishes, the LEDs will go out and the tuning will stop after about 1 second. The resultant tune will be undetermined, it may or may not be a match.

Note: Be sure to note that the tuner induces high SWR (over 3.0 to 1) while trying to find a match. Most of the high SWR only lasts a few milliseconds, but you should make sure that your transmitter can handle those brief periods. Most commercially made transmitters have an SWR protection circuit that lowers the power during high SWR. These radios are normally not effected by the tuning process.

Performance: The actual performance from the small package will surprise you. It really tunes a lot of antennas to a lot of places!

A typical 40 meter dipole (at 30 feet) will tune anywhere from 2.1 to 30 MHz! Average tuning time should be about 1.2 seconds. An Antron-99 (a 10 meter vertical at 40 feet) should tune anywhere from 30 to 4 MHz. In the Auto mode, you can dial down the band and the tuner will kick in when ever the SWR goes over 3.0.

The unit was tested on a friends 3 element tri-band (20,15,10) at 70 feet. It would tune any of the ham bands (including WARC) except 160 and 80. His 80 meter inverted Vee was next. It tuned everything from 1.9 to 30 MHz.

We've tried many other antennas with similar results. There may be a place or two that your antenna (dipole, inverted-Vee, vertical, beam, ect.) won't tune. Also, the farther away from resonance you try to tune, the harder time the tuner will have. The tuner may tune a 10 meter vertical to 80 meters, but your performance will not be that great (you can't get something for nothing).

For balanced lines and random wires, you may get better performance by using a balun between the antenna and tuner.

We used the Autek RF-1 analyzer to give us more information about how well the tuner was working. We found that it would consistently tune impedances from about 6 ohms to about 800 ohms. This corresponds to

an SWR of about 8:1 for Low-Z and 10:1 for Hi-Z.

The SWR bandwidth (usable bandwidth of 1.5 SWR without retuning) averaged about 200 kHz. On the lower frequencies it was smaller (about 75 kHz on 80 meters) and on the higher frequencies it was larger (about 400 KHz on 10), no surprises here.

Trouble Shooting: The tuner goes together very easy and the units that we have prototyped have all worked on the first try. If there are any problems, first check all components for proper value, placement and polarity. Next look at the solder connections. Check for cold joints or solder bridges.

Does nothing: Check for 12 volts getting to PC board. Check for 5.0 volts out of 78L05. Make sure the socket for U1 was installed correctly. Make sure U2 is installed correctly. Check D3 for polarity. Check the SIP resistor for proper orientation. See if the unit is drawing current (about 10-20 mA).

One or more relays energizes on power up: Check for correct positioning of all transistors. If a transistor is found to be bad, just about any 2N3904 type or equivalent will work. The Relay number (K1, K2...) line up with transistor numbers (Q1, Q2...). This will help in matching a bad transistor to its relay.

Can't get 2.5 volts on FWD: Make sure T1 was wound correctly. Check polarity of D1 and D2. Make sure you are getting at least 2 or 3 watts from your transmitter.

LEDs don't work: Check for polarity on LED1-4. The flattened side (or shorter lead) of the LEDs should go to ground. Make sure you are getting at least 0.1 watts from your transmitter. Make sure the ribbon wire was installed correctly.

LEDs work, but won't tune: Check Q1-17 for polarity. Make sure the switches are properly installed. They should ground the line when activated.

LEDs flash randomly: at higher power or relays chatter or unit locks up: Excessive stray RF on board or poor grounding. Tuner may be outside of tuning range.

Tech Support: Telephone technical support is available most days from 6 to 9 pm Eastern Standard Time. Replies by FAX are welcome, e-mail is also answered on a daily basis.

Last Resort: As a last resort only, LDG Electronics will attempt to repair any problems. As much as we

would like to do it for free, we just can't. We have a flat fee of \$30 plus parts to repair a tuner (most resistors and capacitors are included in that fee). The 68HC11 chip is the most expensive at \$20. Relays are \$5 each. The 34064 is \$5. The 78L05 is \$1.

We will not attempt to repair any unit that has been soldered with acid core. We reserve the right to refuse repair due to excessive problems or damage due to construction.

Before any unit is sent to us, you must first call to get return authorization (just so we know your unit is on it's way). All units sent in must be prepaid, either by check, money order or Credit Card unless otherwise indicated. Package unit carefully and keep in mind we will use your packaging to return the unit back to you. Include a description of what problem you are having and a phone number you can be reached at in the evenings in case we have questions. Repairs average about 3 to 6 weeks, depending on the particular problem.

Upgrades: We are continually trying to put more features in the software of the tuner. The current version of the software (QRP 1.0) was locked in with only 4 bytes (out of 512) of code space left.

If you have an idea of how the unit can be made better (in software or hardware), please send a description of your upgrade. If we use it for the tuner, we'll send you a free upgrade. We can mention now that we do not have enough code space to implement tuning from memory or adding an LCD display (but we're working on it). Future upgrades will be available for about \$10 with 68HC11 chip trade in. If you purchased the kit from LDG, we will notify you when upgrades are available. If you did not purchase the unit from LDG and you want to be on our mailing list, just drop us a card, letter, fax or e-mail.

Feedback: We encourage everyone who builds the kit to drop us a note (card, letter or e-mail preferred) to let us know how well it works for you in your particular installation. This will ensure that we have provided everyone with the best tuner kit possible and we can maintain a database of how well the tuner performs.

Fig.1 Block Diagram

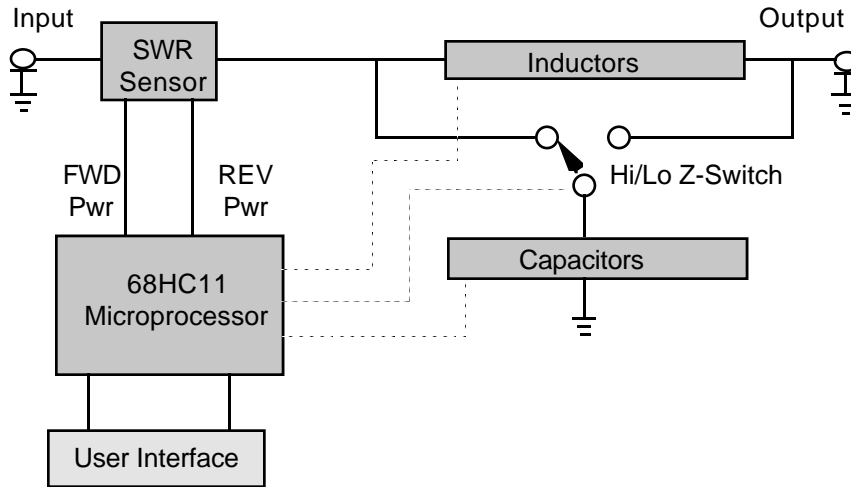

Fig. 2 L1-L4. L2 Shown.

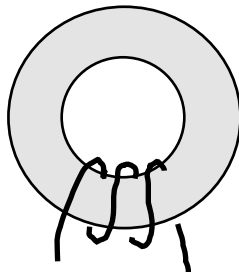

Fig. 3 L5-8. L5 Shown.

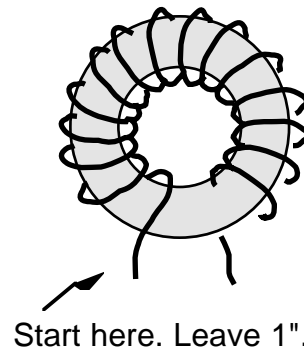

Fig. 4 Inductor Table

<u>Inductor</u>	<u>uH</u>	<u>Turns</u>	<u>Inches needed</u>
L8 Double	10.0	33	36
L7	5.0	32	26
L6	2.5	22	17
L5	1.2	15	12
L4	.62	7 bottom	6
L3	.33	5 bottom	5
L2	.16	3 bottom	3
L1	.09	2 bottom	2

Fig. 5 T1,10 turns #28

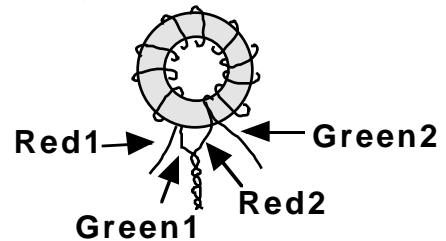

Fig. 6 Capacitor Table

Capacitor	pF (+/-5%)	Combination	
C25	10	10	500V
C26-27	20	10+10	
C28	40	39	
C29	80	82	
<hr/>			
C30	160	150	1000V
C31	320	330	
C32	640	680	
C33-34	1280	680+680	

Fig. 8 14 pin Ribbon Cable Layout

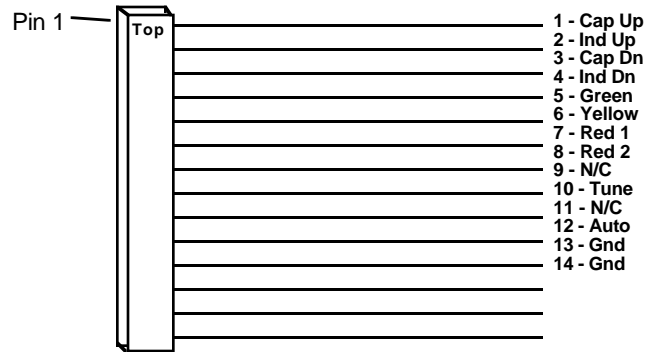

Fig. 7 J3, Control Header

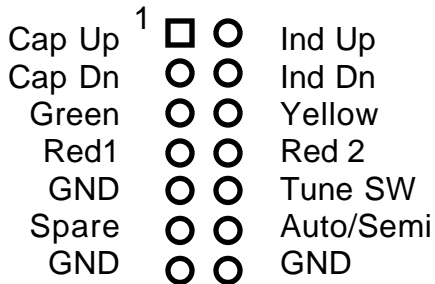

Fig. 9 Front Panel Wiring

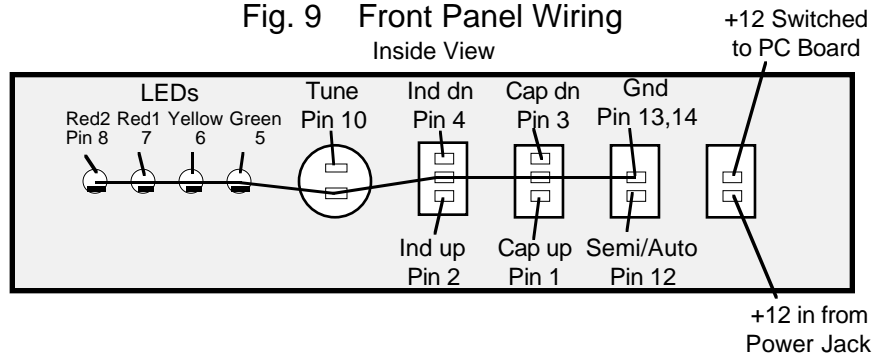
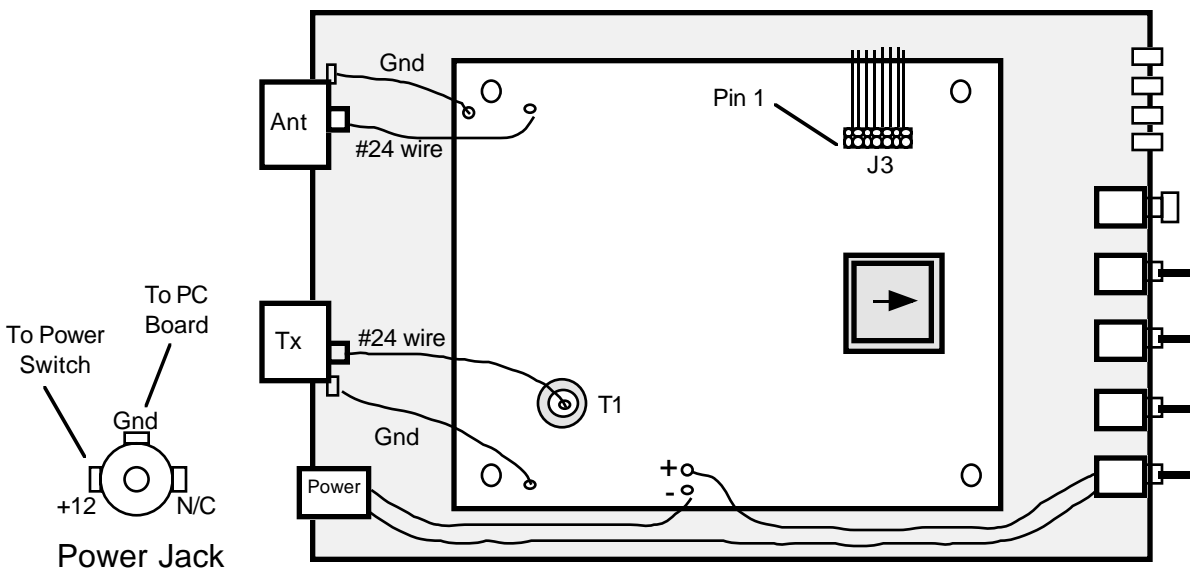
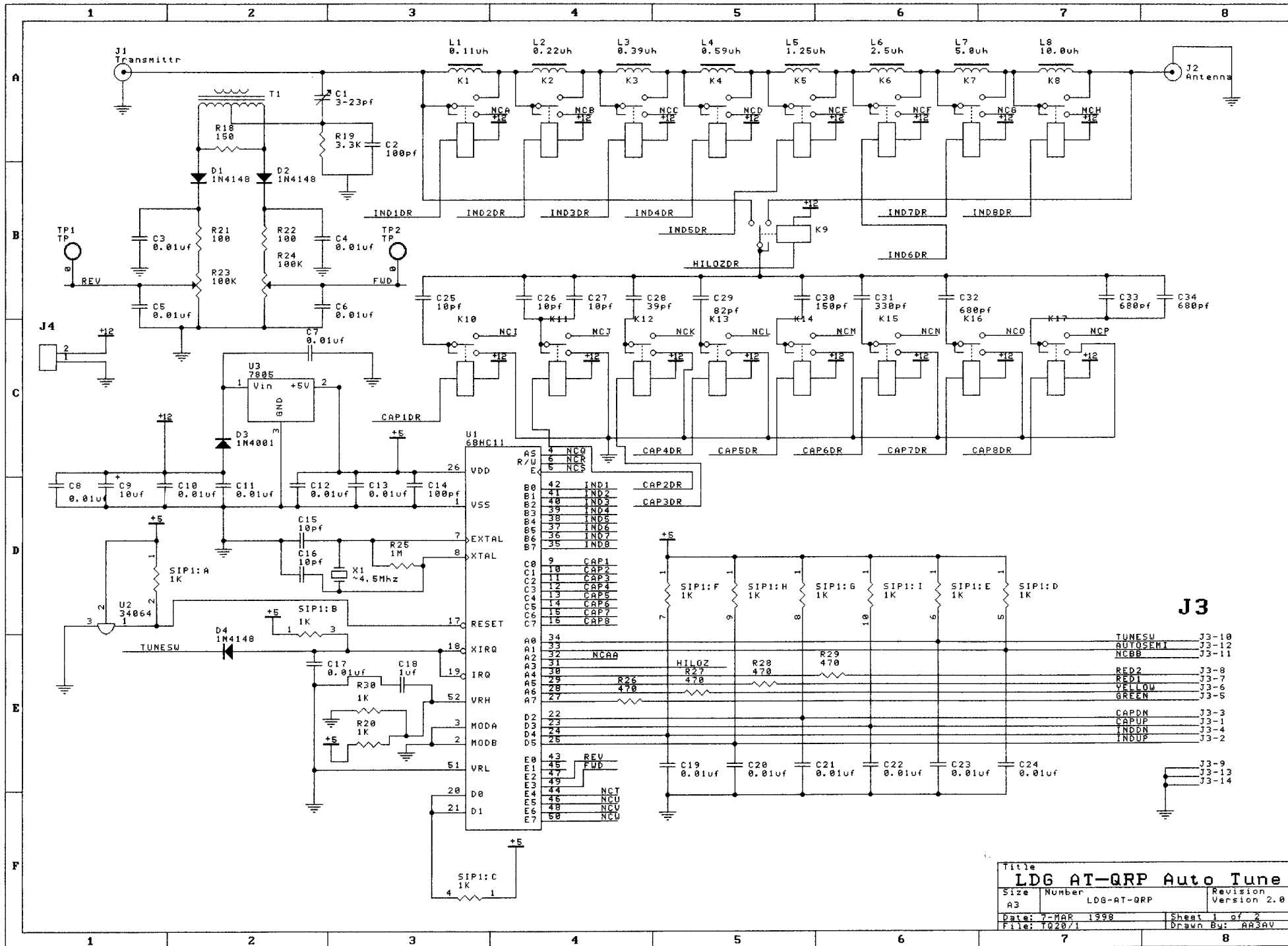

Fig. 10 Chassis Top View





A5	R/U	5	NCQ
A6	R	6	NCR
A7	E	5	NCS
B0		42	IND1
B1		41	IND2
B2		40	IND3
B3		39	IND4
B4		38	IND5
B5		37	IND6
B6		36	IND7
B7		35	IND8
C0		9	CAP1
C1		10	CAP2
C2		11	CAP3
C3		12	CAP4
C4		13	CAP5
C5		14	CAP6
C6		15	CAP7
C7		16	CAP8
A0		34	
A1		33	
A2		32	NCAA
A3		31	HILQZ
A4		30	R27
A5		29	R26
A6		28	470
A7		27	470
D2		22	
D3		23	
D4		24	
D5		25	
E0		43	
E1		45	FUD
E2		47	
E3		49	
E4		44	NCT
E5		46	NCU
E6		48	NCV
E7		50	NCU

Title		
LDG AT-QRP Auto Tune		
Size	Number	Revision
A3	LDG-AT-QRP	Version 2.0
Date:	7-MAR 1998	Sheet 1 of 2
File:	T020/1	Drawn By: AA3AV

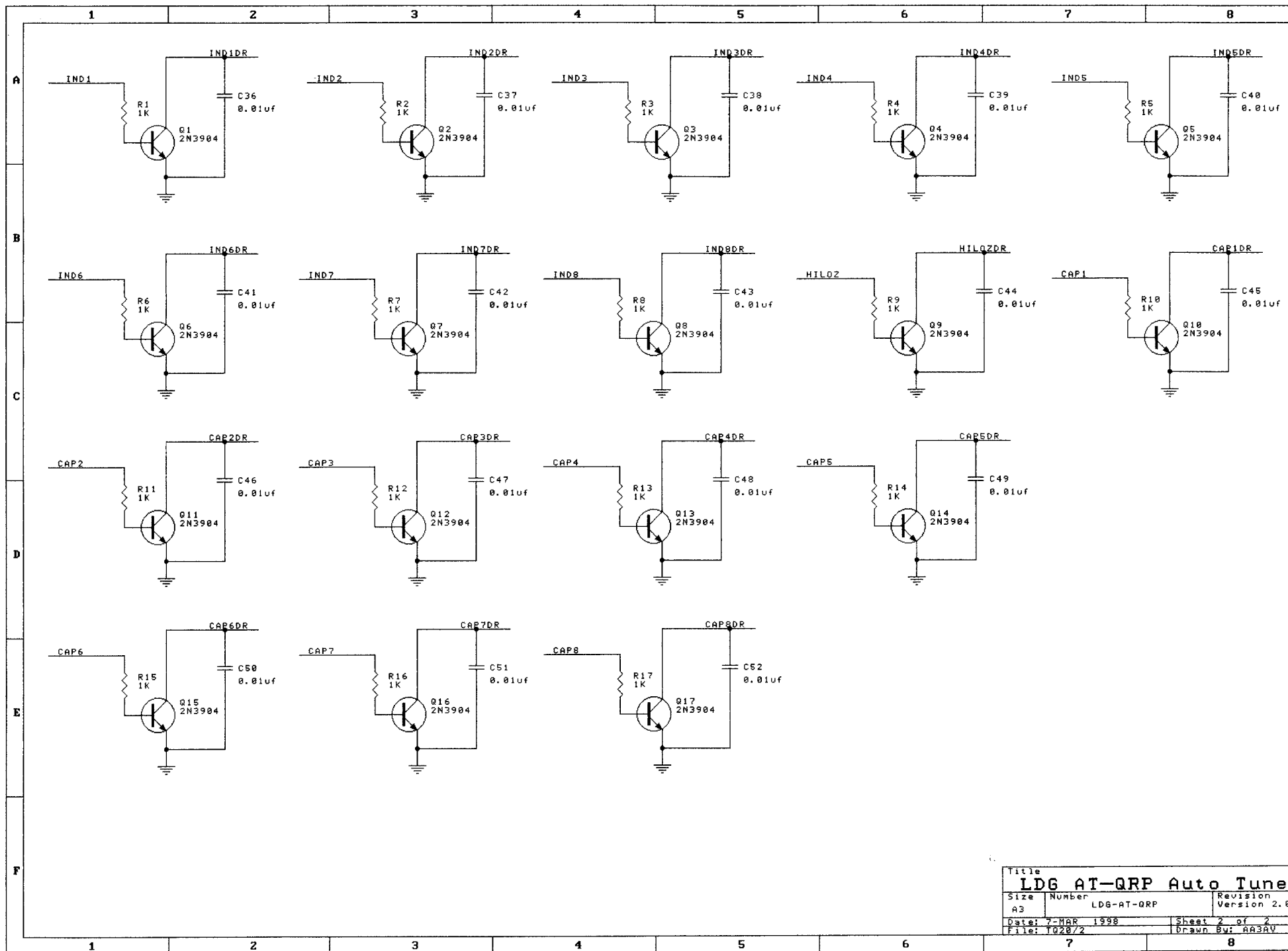

Title		
LDG AT-QRP Auto Tune		
Size	Number	Revision
A3	LDG-AT-QRP	Version 2.0
Date:	7-MAR 1998	Sheet 2 of 2
File:	TQ20/2	Drawn By: AA3AV

QRP Parts List Ver 2.0

	List #	Part Description	Qty
[]	L1-8	Iron Toroid T50-2	9
[]	T1	Ferrite Toroid FT-37-77	1
[]	Wire	#24 Thermeleze	10'
[]	Wire	#28 Red	8"
[]	Wire	#28 Green	8"
[]	U1	68HC11A1FN	1
[]	U2	34064	1
[]	U3	78L05	1
[]	X1	4.5 Mhz Crystal	1
[]	Socket1	52 Pin PLCC	1
[]	D1,2,4	1N4148	3
[]	Q1-17	2N3904	17
[]	D3	1N4001 1A/100V	1
[]	K1-17	SPDT Relay	17
[]	R1-17,20,30	1K 1/8w	19
[]	R21,22	100 1/8w	2
[]	R25	1M 1/8w	1
[]	R18	150 1/8w	1
[]	R19	3.3K 1/8w	1
[]	R26-29	470 1/8w	4
[]	SIP1	10 pin SIP	1
[]	R23,24	100K pots	2
[]	C1	3-23 pf Trimmer	1
[]	C3-8,10-13,17,19-24,36-52	0.01 uf 50V Mono	34
[]	C9	10 uf 25V or 50V	1
[]	C18	1.0 uf 25V or 50V	1
[]	C15,16,25-27	10 pf 500V	5
[]	C28	39 pf 500V	1
[]	C29	82pf 500V	1
[]	C2,C14	100pf 500V	2
[]	C30	150pf 1000V	1
[]	C31	330pf 1000V	1
[]	C32-34	680pf 1000V	3
[]	J3	2 x 7 Header Pin	1
[]	Cable	14 Wire Ribbon Cable	1
[]	QRP Ver 2.0 PCB	PC Board	1
[]	QRP Ver 2.0b Manual	Manual	1
[]	QRP Ver 1.0 Enclosure	Enclosure	1
[]	J1, 2	SO-239 Chassis Mount	2
[]	J3	Power Jack	1
[]	P1	Power Plug	1
[]	S1, S2	SPST 1/4"	2
[]	S3, S4	SPDT Momentary 1/4"	2
[]	S5	Push Button	1
[]	LED 1	5mm Green LED	1
[]	LED 2	5mm Yellow LED	1
[]	LED 3,4	5mm Red LED	2
[]	Bolt	#4	8
[]	Nut	#4	8
[]	Washer	#4	8

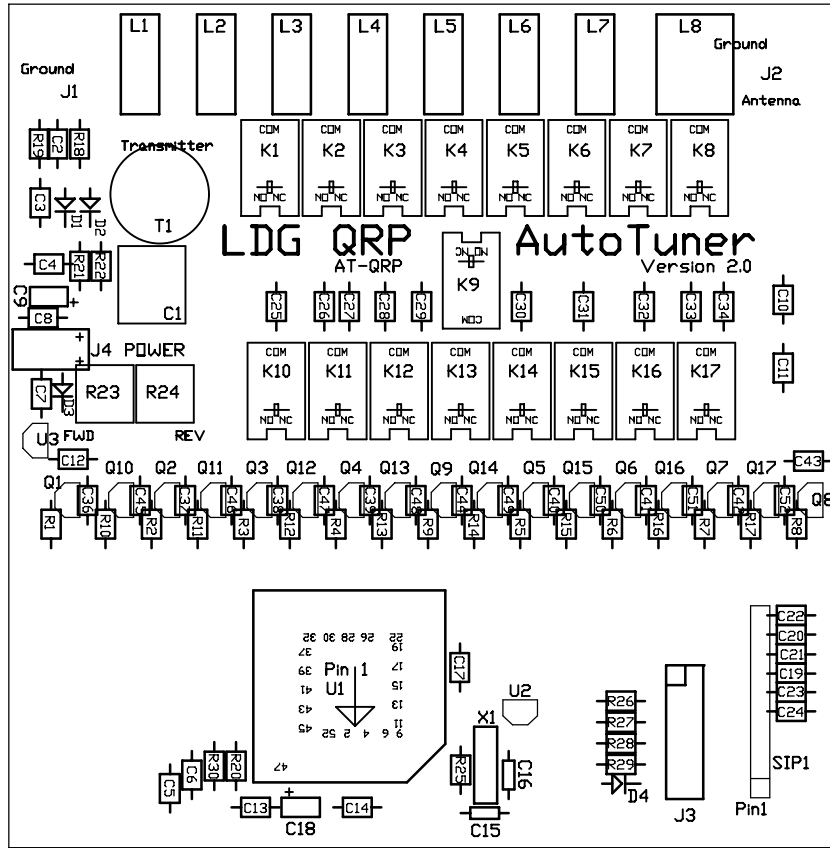

TQ20 Top Overlay

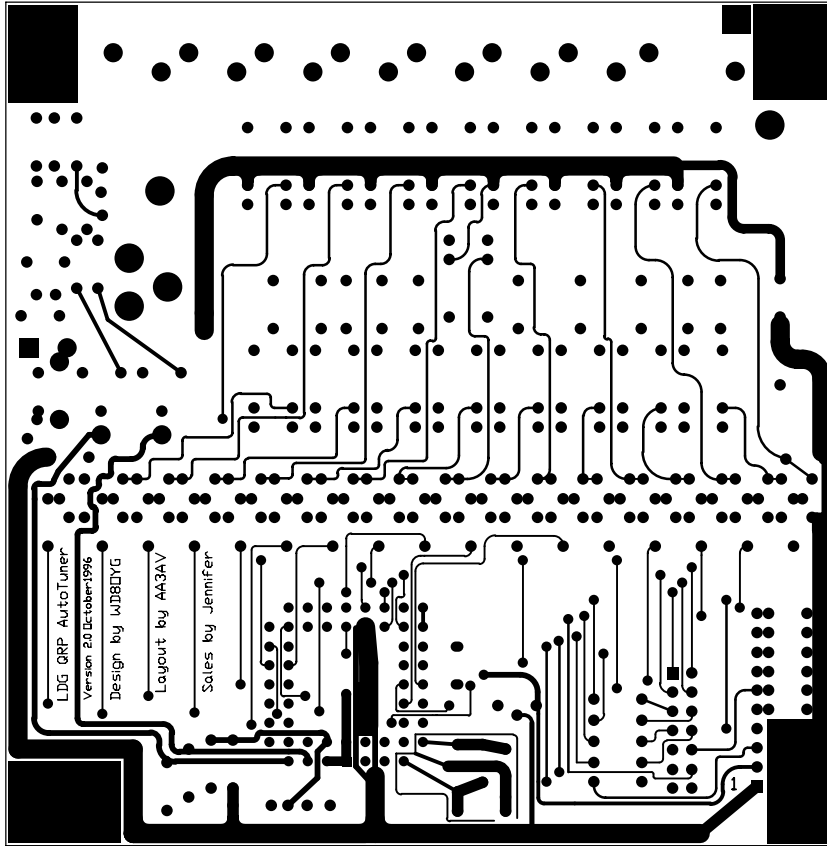

TQ20 Top Layer

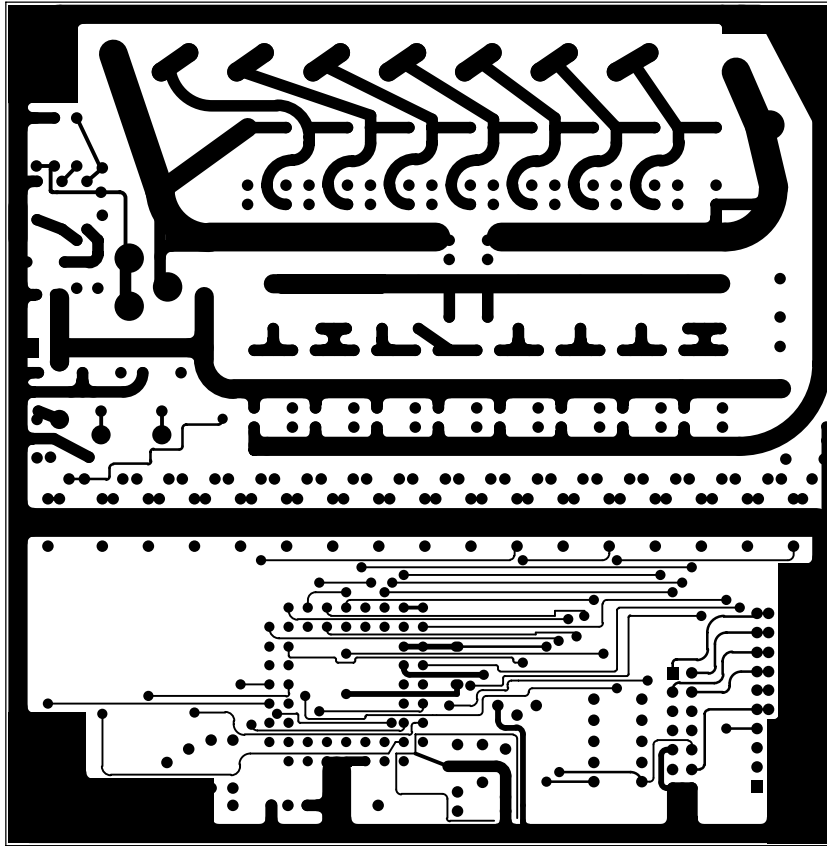

TQ20 Bottom Layer

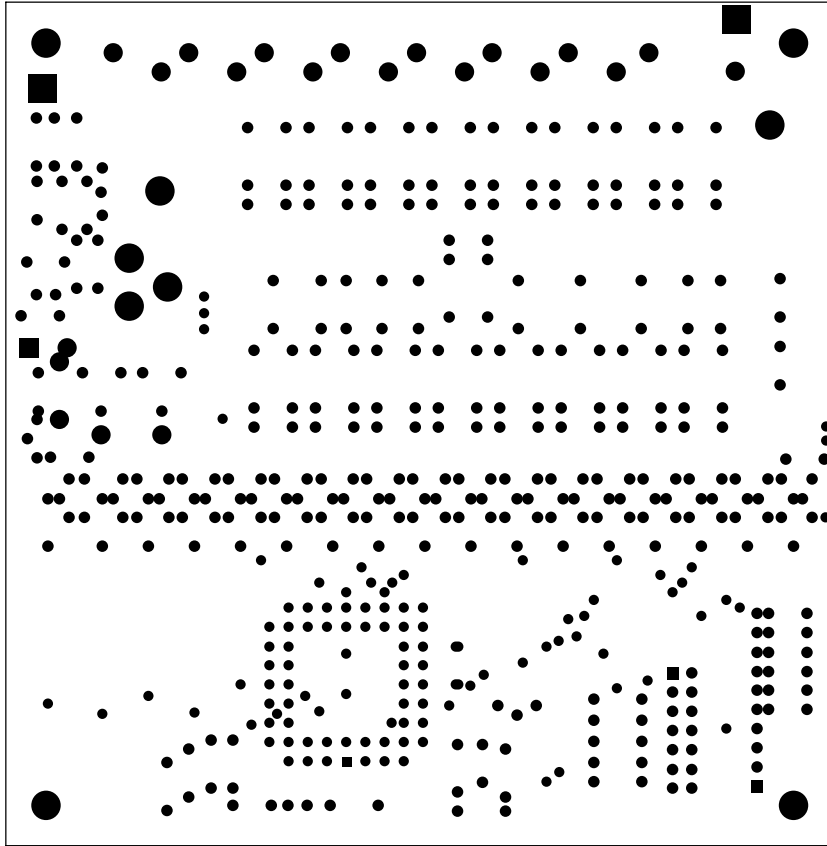

TQ20 Top Solder Mask

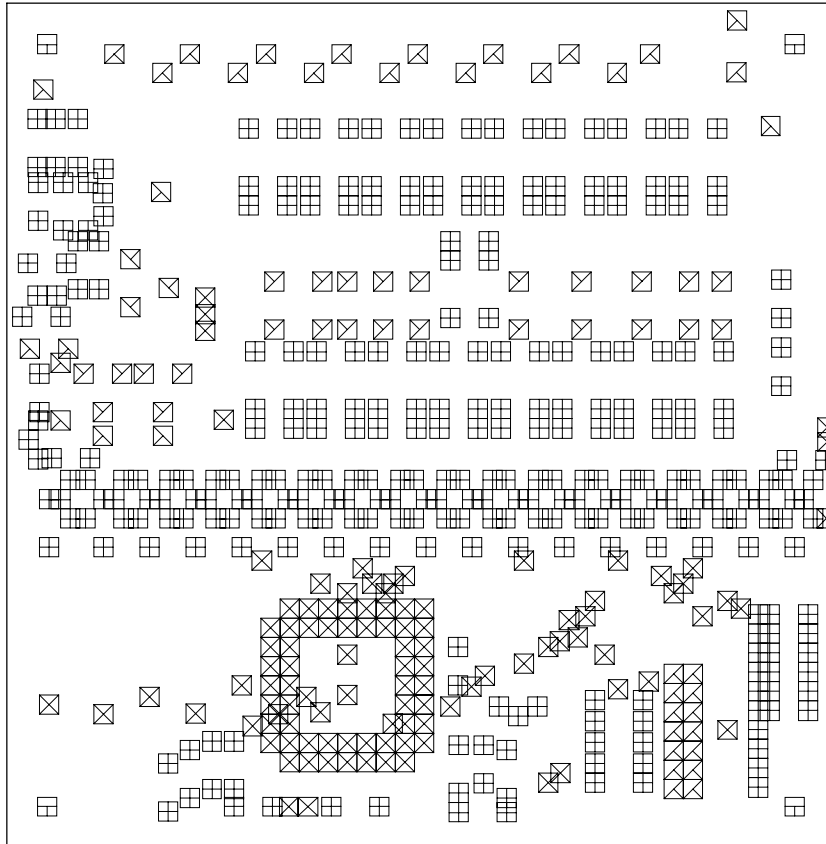

	mils	Count
☒	28	107
▣	32	314
☒	35	26
☒	42	30
☒	52	10
☒	86	3
▣	125	4

Total 494

TQ20 Drill Drawing

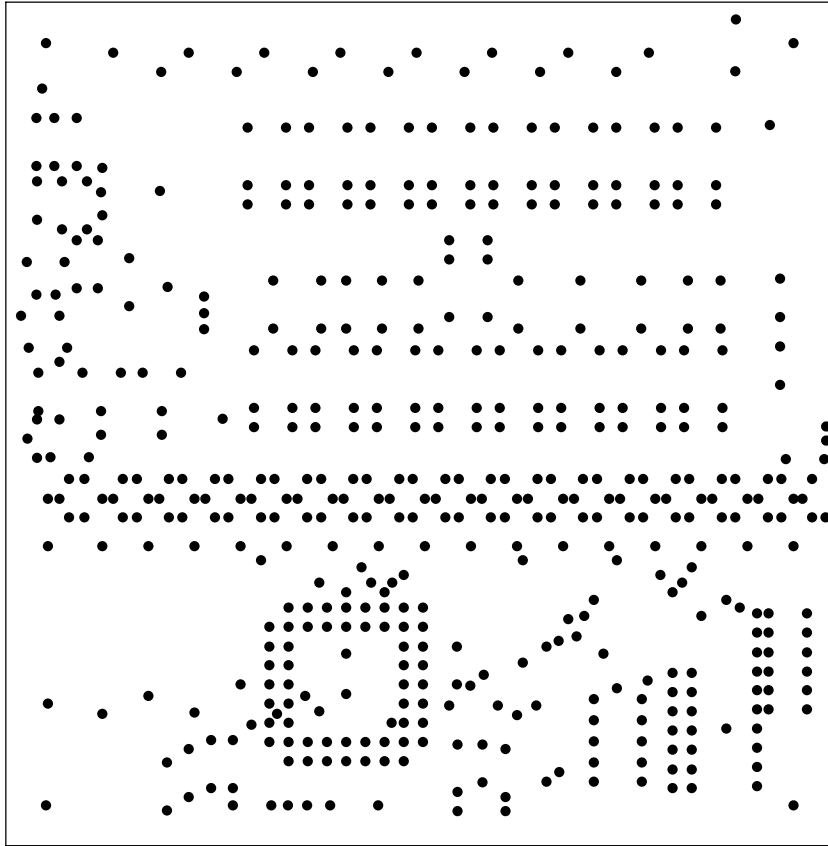

TQ20 Drill Guide