

MAC-200

Master Antenna Controller

Catalog Number 54-25

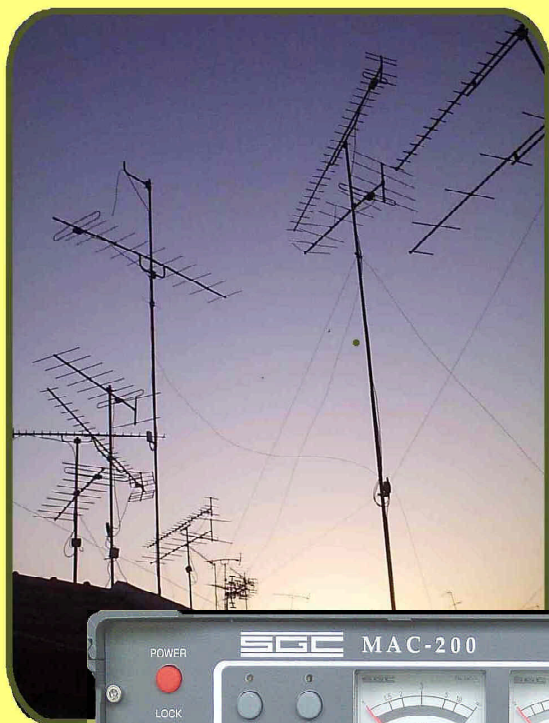

Thank you for buying your new MAC-200 Master Antenna Controller. The MAC-200 incorporates the very latest American-made technology as well as our experience in having delivered more than 100,000 Smartuners since 1985. It is a state-of-the-art tuner providing a new and unique level of usefulness.

The concept of the MAC-200 is quite different from our line of Smartuners. Instead of dedicating one Smartuner per antenna, we've brought the tuner to the point where all of the antennas come together: the radio room. The MAC-200 provides tuning for all antennas in a single box. The ease of installation and flexible operation make this an ideal choice. We know that the simplicity, reliability, and flexibility of the MAC-200 will enhance your HF operation for years to come.



SGC continues to focus on providing the most useful products and services for our customers around the world. Please feel free to call to discuss your antenna system requirements at any time. We look forward to making your HF experience the very best.

A handwritten signature in black ink that reads "Pierre Goral". The signature is fluid and cursive.

Pierre Goral
President, SGC Inc.

© 2003 SGC Inc.

PO Box 3526, Bellevue, WA. 98009 * 13737 SE 26th St. Bellevue, WA. 98005

Toll Free: 800-259-7331 * Phone: 425-746-6310 * Fax: 425-746-6384

www.sgeworld.com * Email: sgc@sgeworld.com

NOTICES

READING THIS MANUAL: The most important sections to read in this manual are MAC-200 SETUP (section 3) and MAC-200 OPERATION (section 4). All users should read and understand this material. Other information such as Theory of Operation is available for those who want to understand their new MAC-200 more completely.

ATTENTION: The MAC-200 RF Path is open when power is off in both receive and transmit modes. To prevent damage to transceivers, do not operate with power off to this device.

NOTE: For efficient operation of the MAC-200, apply 12 VDC from the same power supply as the transceiver.

NOTE: The MAC-200 is not designed for mobile applications. SGC recommends the SG-230, 231, 235, or 237 for mobile installations.

NOTE: SGC does not guarantee 100% calibration of the front panel meters. If an accurate indication of power or SWR is desired, an external meter should be used to develop an instrument calibration table for the front panel meters.

QUICK START

1. **Automatic Mode Programming**
 - a. Check auto light on
 - b. Select antenna
 - c. While AUTO LED is blinking, apply RF power
 - d. MAC-200 stores tuning & antenna settings
2. **Manual Mode Operation**
 - a. Check manual light on
 - b. Select antenna
 - c. MAC-200 stores tuning settings only
3. **Backlighting selection - During power up**
AUTO pressed – backlight ON
MAN pressed – backlight OFF
4. **Keytones selection - During power up**
20W pressed – keytones ON
200W pressed – keytones OFF
5. **Lock Function – ignores all tuning instructions**
6. **Reset Function – resets MAC-200 to power on state**

Antenna Storage Frequency Bins (upper limit)

Freq (Mhz)	
2.836	19.600
5.754	23.488
8.760	26.431
12.653	30.000
16.626	>30.000

PO Box 3526, Bellevue, WA. 98009 13737 SE 26th St. Bellevue, WA. 98005

Toll Free: 800-259-7331 * Phone: 425-746-6310 * Fax: 425-746-6384

www.sgcworld.com * Email: sgc@sgcworld.com

Table of Contents

1	INTRODUCTION	4
2	TECHNICAL SPECIFICATIONS	6
3	MAC-200 SETUP	7
3.1	MECHANICAL DESIGN	7
3.2	CONNECTIONS TO THE MAC-200	8
3.3	ANTENNAS AND THE MAC-200	15
3.4	THE GOLDEN RULES OF HF INSTALLATION	27
4	MAC-200 OPERATION	29
4.1	POWERING ON THE MAC-200	29
4.2	SELECTING THE METER RANGE	31
4.3	SELECTING THE OPERATING ANTENNA	31
4.4	AUTO VS. MANUAL ANTENNA SELECTION	32
4.5	FRONT PANEL RESET-LOCK OPERATION	34
4.6	DO-IT-YOURSELF LIGHT BULB TEST	35
5	THEORY OF OPERATION	39
5.1	TUNING PROCESS AND OPTIONS	39
5.2	SCHEMATICS	57
5.3	COMPONENT LOCATION	63

PO Box 3526, Bellevue, WA. 98009 13737 SE 26th St. Bellevue, WA. 98005
Toll Free: 800-259-7331 * Phone: 425-746-6310 * Fax: 425-746-6384
www.sgcworld.com * Email: sgc@sgcworld.com

1 Introduction



Why did we create the MAC-200? To pull together the essential tools for antenna management for stations with more than one antenna. Discussions with amateurs and professionals have shown that most have more than one antenna, yet the only place where all of these antennas come together is in the radio room. Only there is it possible to manage the antenna in use and provide matching for all of them. Unfortunately, existing tools do not go far enough.

From manual antenna switches, to complex, electronic, computer controlled antenna switches ... the only thing available has been a switch. Existing devices allow directing RF to one antenna or another from a group of antennas. Some manual tuners provide for two or sometimes three antennas with an ability to tune them, but now SGC has taken the next step and added an intelligent tuner to the control station.

The MAC-200 is something completely new, an antenna switching system that includes built in intelligent tuning to trim the line before going into your transceiver. The MAC-200 has 170 built in memories to remember both the tuning parameters and the antenna at a variety of frequencies. It has all of the sophistication

PO Box 3526, Bellevue, WA. 98009 13737 SE 26th St. Bellevue, WA. 98005

Toll Free: 800-259-7331 * Phone: 425-746-6310 * Fax: 425-746-6384

www.sgcworld.com * Email: sgc@sgcworld.com

developed over the years with SGC's Smartuner line of antenna couplers. However, the MAC-200 is an antenna TUNER intended for installation near the transceiver rather than at the antenna feed point..

The MAC-200, located as it is in the radio room at the point where all antenna feed lines come together, provides tuning at the end of the antenna feed line rather than at the optimum point, the antenna feed point. SGC Smartuners provide for matching of an antenna to the feed line, thereby minimizing SWR and losses on the line. The MAC-200 allows control of multiple antennas from a single box and tuning the antenna system in order to connect to the transceiver, but it must match the impedance as reflected by the transmission line to the device.

PO Box 3526, Bellevue, WA. 98009 13737 SE 26th St. Bellevue, WA. 98005
Toll Free: 800-259-7331 * Phone: 425-746-6310 * Fax: 425-746-6384
www.sgcworld.com * Email: sgc@sgcworld.com

2 Technical Specifications

HF Frequency Range	1.8-60Mhz
Power Input	1.5-200 watts PEP
Number of Inputs	1 type SO239
Revolving Memory Bins	168
Number of Outputs	5 – 1 End Fed, 1 Balanced Feed, 3 Coaxial
Network	Pi Configuration
Impedance Range	
Longwire	.2-5000 ohms
feedline	5-1000 ohms
Balanced Output	5-1000 ohms
VSWR	Typically less than 2:1
DC Input Requirement	+13.8 VDC (nominal)
DC Operating Range	+10 to 18.5VDC
Input Current	230 milliamps average
Random Set Time	Typically < 2 seconds
Recurrent Set Time	Typically < 10 ms
Antenna Length (Long Wire)	Minimum 9 ft – 7-30Mhz
	Minimum 40 ft - 3-30Mhz
	Minimum 100 ft – 1.8-30Mhz
Installation	Desktop
Operating Temperature	-35 to +70C
Size	6.5 X 3 X 8.5 inches
Weight	5 pounds
Case Construction	Extruded Aluminum
Meters	1 SWR
	1 Power with 20 & 200 watt scales
Cable Connections	Standard Coaxial PLUS
	Standard mini-plug for DC PLUS
	Lugs for wire antennas and ground

PO Box 3526, Bellevue, WA. 98009 13737 SE 26th St. Bellevue, WA. 98005

Toll Free: 800-259-7331 * Phone: 425-746-6310 * Fax: 425-746-6384

www.sgcworld.com * Email: sgc@sgcworld.com

3 MAC-200 Setup

3.1 Mechanical Design

The MAC-200 is in an aluminum case. RF and DC power come through the back of the case. Internal construction is normal for fixed location use. Corrosion-resistant hardware and passive alloys are used throughout. For 99% of installations, the factory settings for the internal jumpers will be correct.

3.1.1 Opening the MAC-200

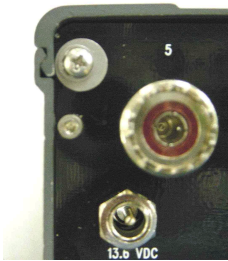

The MAC-200 cover is locked in place with a simple arrangement using an oversized washer to engage a small groove in the side of the cover to prevent its movement. A #4 screw and a slightly oversized washer (#6 or #8) are locked in place by a lock washer to prevent movement of the cover.

In order to open the MAC-200 to get at the JP1 or JP3 jumpers or to visually inspect the circuit boards, you need to do the following:

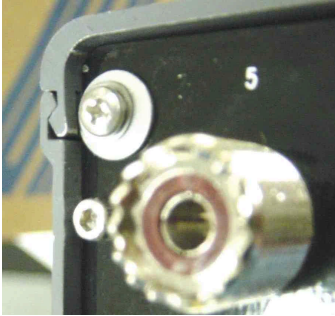

1. Loosen the cover lock on the back panel of the MAC-200 until the washer disengages from the MAC-200 cover.
2. Slide the cover forwards or backwards until it disengages from the rail.

To re-close the cover:

1. Orient the cover so that the small groove for the locking washer is at the back of the MAC-200
2. Engage the cover with the body of the MAC-200 from the front or the back and slide it into place.
3. Holding the MAC-200 with the back panel UP, push the washer into the slot engaging the cover slot and drive the screw into the hole until tight.

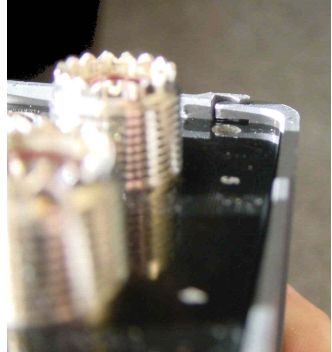

3.2 Connections to the MAC-200

PO Box 3526, Bellevue, WA. 98009 13737 SE 26th St. Bellevue, WA. 98005

Toll Free: 800-259-7331 * Phone: 425-746-6310 * Fax: 425-746-6384

www.sgcworld.com * Email: sgc@sgcworld.com

All connections to the MAC-200 are made on the back panel.

NOTE: Under normal operating conditions, it is good practice to connect a dummy load to one of the 50-Ohm antenna connectors in order to have it available for test purposes.

3.2.1 12 VDC Power

ATTENTION: The MAC-200 RF Path is open when power is off in both receive and transmit modes. To prevent damage to transceivers, do not operate with power off to this device.

NOTE: For efficient operation of the MAC-200, apply 12 VDC from the same power supply as the transceiver.

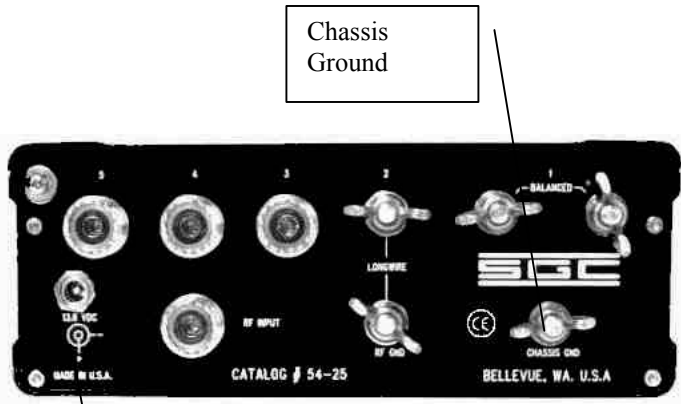

12 VDC

The MAC-200 has a miniature power input jack on the back panel. Any voltage from 10 to 18.5 VDC is suitable for operation. Average current draw will be approximately 230 milliamps. The MAC-200 should be powered from the same power source used to supply your transceiver to ensure that it is energized whenever the transceiver is in operation.

3.2.2 RF Input from your transceiver

A standard SO-239 jack is for RF Input from your transceiver.

3.2.3 Chassis Ground

PO Box 3526, Bellevue, WA. 98009 13737 SE 26th St. Bellevue, WA. 98005
Toll Free: 800-259-7331 * Phone: 425-746-6310 * Fax: 425-746-6384
www.sgeworld.com * Email: sgc@sgeworld.com

The chassis ground should be connected to a suitable station safety grounding system.

3.2.4 Connecting Antennas to the MAC-200

3.2.4.1 Coax antenna feeds

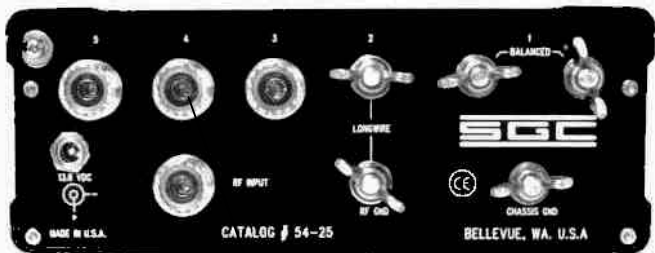

SO-239
Connectors
for Coaxial
Cable

Three SO-239 connectors are provided for antennas fed with Coaxial cable. SGC recommends that one connector be reserved for a dummy load if possible for testing purposes. From the front panel, these three connections correspond to switches 3, 4, and 5.

PO Box 3526, Bellevue, WA. 98009 13737 SE 26th St. Bellevue, WA. 98005
Toll Free: 800-259-7331 * Phone: 425-746-6310 * Fax: 425-746-6384
www.sgeworld.com * Email: sgc@sgeworld.com

3.2.4.2 Long Wire Connections

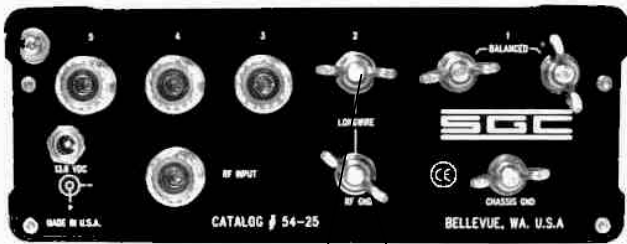

Long Wire (unbalanced)
RF Hot Connection

Long Wire (unbalanced)
RF Ground Connection

The long wire connection starts from two lugs on the back panel labeled 'Longwire.' They correspond to antenna selection switch 2 on the front panel. An RF ground connects to the lug labeled RF GND. When using a single wire 'counterpoise, it should be 5-10% longer than the random length long wire.

IMPORTANT NOTE: A long wire connected at the back will be radiating from the moment it leaves the MAC-200. This can lead to excessive RF levels within the radio room at even modest power levels. The length of wire within the radio room needs to be kept to a minimum.

3.2.4.3 Balanced Feed Connections

PO Box 3526, Bellevue, WA. 98009 13737 SE 26th St. Bellevue, WA. 98005
Toll Free: 800-259-7331 * Phone: 425-746-6310 * Fax: 425-746-6384
www.sgcworld.com * Email: sgc@sgcworld.com

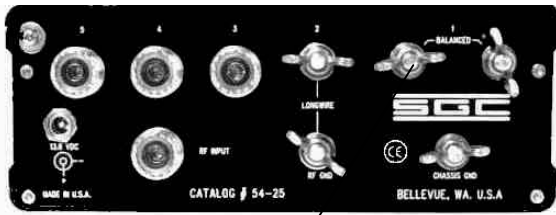

Balanced
Feed Line
Connection

The balanced feed connections corresponding to antenna switch 1, will accept any form of balanced feed line for an external antenna.

PO Box 3526, Bellevue, WA. 98009 13737 SE 26th St. Bellevue, WA. 98005
Toll Free: 800-259-7331 * Phone: 425-746-6310 * Fax: 425-746-6384
www.sgcworld.com * Email: sgc@sgcworld.com

3.2.4.4 Multiple Antenna Connections

The MAC-200 was designed specifically to allow multiple antenna types with multiple feed lines to be controlled from a single location. Up to five different antennas can be connected, three fed by coaxial lines, one with an unbalanced line, and one with a balanced line. All of these are switch selectable from the front panel.

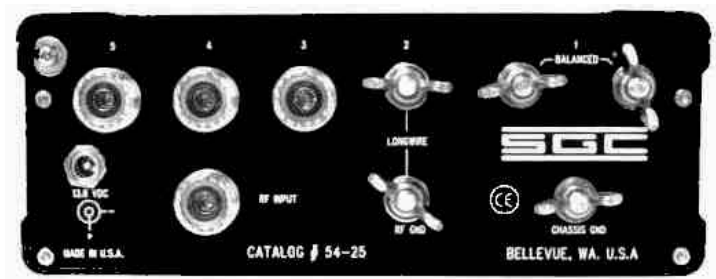

PO Box 3526, Bellevue, WA. 98009 13737 SE 26th St. Bellevue, WA. 98005
Toll Free: 800-259-7331 * Phone: 425-746-6310 * Fax: 425-746-6384
www.sgeworld.com * Email: sgc@sgeworld.com

3.3 Antennas and the MAC-200

The MAC-200 can accommodate a wide variety of antennas providing a convenient way to switch between them and to tune them, all in the same box.

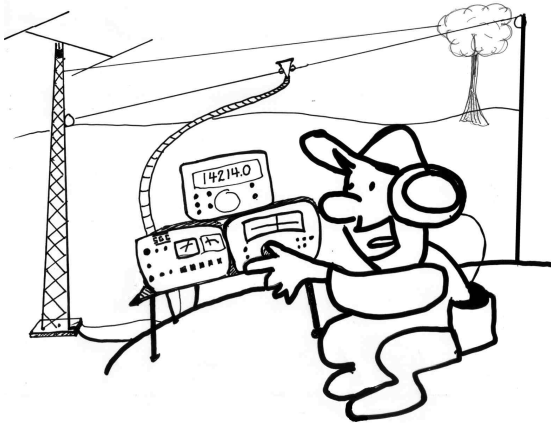

3.3.1 Optimum Coupling

The MAC-200 incorporates a coupler internally to provide for tuning on a variety of antennas under direct control of the user. This is a compromise location. The optimum location is the antenna feed point where the impedance match keeps SWR on the feed line to an absolute minimum.

PO Box 3526, Bellevue, WA. 98009 13737 SE 26th St. Bellevue, WA. 98005
Toll Free: 800-259-7331 * Phone: 425-746-6310 * Fax: 425-746-6384
www.sgeworld.com * Email: sgc@sgeworld.com

3.3.2 Connecting Multiple Antennas

The MAC-200 is provided with 3 SO-239 connectors, one RF-Hot/RF-GND pair, and one balanced feed connection. The SO-239 connectors are intended to connect to a normal Coaxial feedline. Any antenna that is properly setup for Coax feed can be connected to one of these connectors..

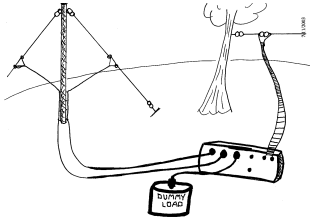

One common benefit of having a switchable antenna controller is the ability to leave a dummy load connected so that you can switch to it conveniently at need.

The RF Hot/RF GND connections feed a long or random wire antenna. They can feed any unbalanced antenna with RF Hot connected to the radiator and RF GND to the RF Grounding system.

IMPORTANT NOTE: The RF-Hot connection will radiate RF from any wire connected to it. Not only is this an RF Hazard within the station, but it can cause local interference both within the station and in the vicinity depending on your power level.

The balanced feed connection is for a ladder line feed connecting to a balanced antenna like a dipole or a loop.

3.3.3 Balanced vs. Unbalanced Antennas

An important distinction is between balanced and unbalanced antennas. Balanced antennas are electrically balanced

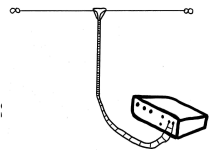

PO Box 3526, Bellevue, WA. 98009 13737 SE 26th ;
Toll Free: 800-259-7331 * Phone: 425-746-6310
www.sgeworld.com * Email: sgc@sgc.com

at the feed point. Typical balanced antennas are dipoles and loops.

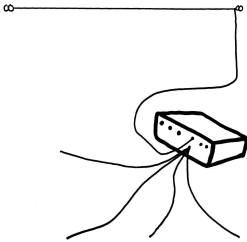

Unbalanced antennas need an RF Ground or counterpoise to create electrical balance and depend on the quality of the ground for a high quality radiated signal. Without a good quality ground, unbalanced antennas will cause interference, lead to RF in the radio room, and be of very low efficiency due to high losses in the ground. Typical unbalanced antennas are long wires and verticals.

3.3.4 Antennas with Feed Point Tuning

Any antenna with a feed point tuner, such as an SGC Smartuner, will work compatibly with the MAC-200. You can either leave the MAC-200 to tune as it needs to or cut out the tuning function by doing the following:

- Select the antenna
- Push the MANUAL button to disengage automatic tuning
- Press RESET to reset the coupler to bypass mode
- Push the LOCK button to lock the coupler.

3.3.5 Antenna Recommendations

There are many ways to connect antennas for use. Here are some common examples that can help you get started with your MAC-200. For additional information about antennas, we recommend that you obtain a copy of our HF User's Guide from our website at

PO Box 3526, Bellevue, WA. 98009 13737 SE 26th St. Bellevue, WA. 98005
Toll Free: 800-259-7331 * Phone: 425-746-6310 * Fax: 425-746-6384
www.sgeworld.com * Email: sgc@sgeworld.com

For detailed technical information about antennas, the consistently best source is the ARRL Antenna Handbook.

3.3.5.1 Dipoles

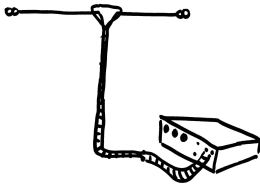

Balanced antennas can be connected to the balanced line connections on the back of the MAC-200.

Some balanced antennas, such as the doublet, have a coax feed at the center point. Simply connect your coax feed line to the MAC-200 at connectors 3, 4, or 5.

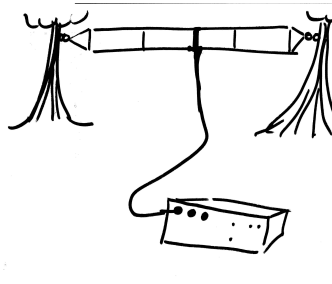

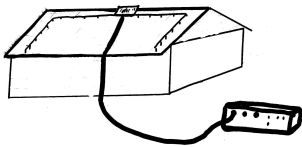

Stealthy antennas are built in a variety of ways. A simple example is a roof-mounted dipole with its ends bent 90 degrees and fed from the MAC-200.

3.3.5.2 The Inverted V Antenna

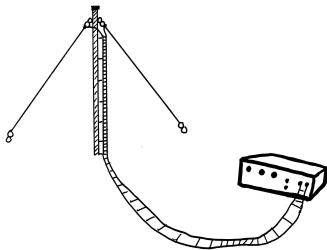

The inverted-V antenna can be fed with ladder line run from the balanced line connection on the MAC-200, but it is also commonly fed from coaxial cable with the center conductor to one side and the shield to the other.

3.3.5.3 Dipoles with Matching Lines

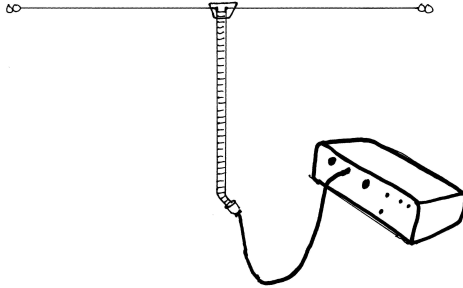

Some antennas, such as the G5RV, use a section of ladder line as a matching device. These transform the impedance of feed point to something near 50 ohms. Usually, the ladder line terminates in a 1:1 balun. The Coaxial line from the transceiver connects to the balun. The MAC-200 can feed this connection directly from one of the coax ports or you can remove the balun run the ladder line directly to the MAC-200 balanced feed line port.

PO Box 3526, Bellevue, WA. 98009 13737 SE 26th St. Bellevue, WA. 98005

Toll Free: 800-259-7331 * Phone: 425-746-6310 * Fax: 425-746-6384

www.sgeworld.com * Email: sgc@sgeworld.com

3.3.5.4 Long Wires & Inverted Ls

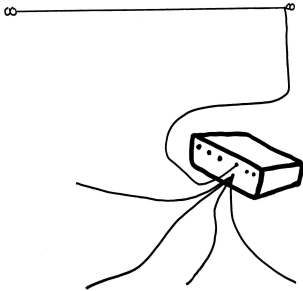

Long wire and inverted L antennas are unbalanced antennas. They are fed from the upper LONGWIRE connection directly with a single wire.

CAUTION: Unbalanced antennas are radiating from the line as soon as they leave the MAC-200. Minimize the amount of wire inside the radio room to prevent interference with electronic equipment. Minimizing power will also minimize interference caused by this kind of antenna.

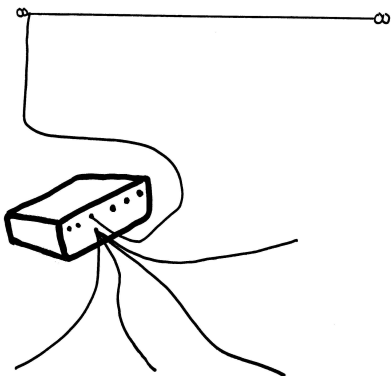

More than any other factor, a good RF ground will help to improve the radiated signal from these antennas and minimize RFI generated by the antenna.

As a minimum, an RF Ground can consist of a wire 5-10% longer than the wire antenna and laid out so that it does

not cross over itself or form a loop. A far better RF ground can be constructed by adding ground radials connected to the RF GND lug on connector 2 of the MAC-200.

3.3.5.5 Vertical Antennas

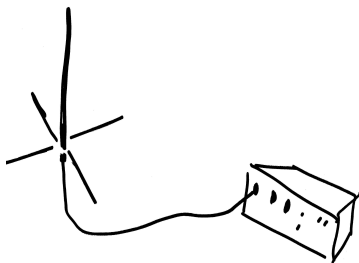

A vertical antenna may be connected to the MAC-200 in a number of ways. Most vertical antennas will require an RF Ground system to function properly, but this may be incorporated into the design of the antenna itself.

A typical vertical antenna is the GROUND PLANE design that incorporates radials within the design. This, and many other vertical antennas use an SO-239 connector or equivalent to feed

PO Box 3526, Bellevue, WA. 98009 13737 SE 26th St. Bellevue, WA. 98005

Toll Free: 800-259-7331 * Phone: 425-746-6310 * Fax: 425-746-6384

www.sgcworld.com * Email: sgc@sgcworld.com

the antenna. This type of antenna should be connected to one of the three SO-239 connectors on the MAC-200 (switches 3, 4, or 5).

Any vertical antenna fed with Coaxial cable can be connected in this way.

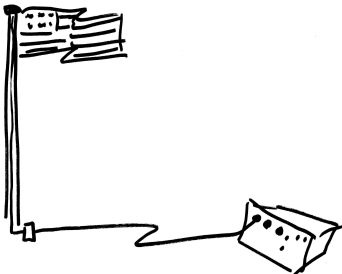

Home made vertical antennas are commonly made in one of two ways. A very common type of construction builds the radial system at the base of the antenna. Flag pole antennas are normally built in this way. Coax line can be run from the MAC-200 to the base of the antenna. The center lead of the coax will feed the radiating

element in the flagpole vertical while the coax shield will be connected to the RF grounding system.

Another way that a vertical can be fed is to have it fed with a wire directly from the MAC-200 with the RF grounding system also connected directly to the MAC-200. In this case, the vertical will be connected exactly like a long wire antenna to the LONGWIRE lugs with the vertical element connected to the top lug and the RF Grounding system connected to the RF GND connector. This configuration could be a very poor radiator unless the feed line is elevated from the ground. The feed wire in this case will be part of the RF radiating system.

3.3.5.6 Loops

Loop antennas are balanced antennas that are very simple to feed from a balanced feed line. Ideally, a Smarttuner would be at the loop feed point, but when using the MAC-200, balanced feedline will minimize SWR between the MAC-200 and the loop. A loop would typically be connected to the MAC-200 at the BALANCED connection (switch position 1).

Loops can be conveniently arranged either horizontally or vertically, but the feeding arrangement from the MAC-200 would be the same.

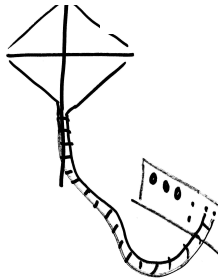
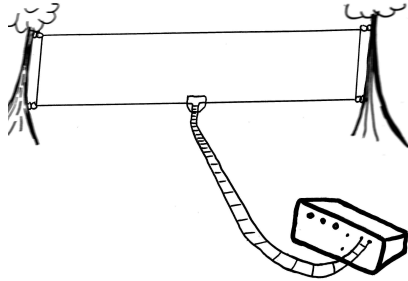

Loops can take on nearly any closed shape such as a square, rectangle, triangle, or diamond shape and they can be fed on the sides or in the corners. The impact of different configurations and feed points is well documented in the many

books on antennas.

It is also possible to feed a loop from a Coax connection by connecting one side of the feed point to the center conductor and the other side of the feed point to the coax shield.

PO Box 3526, Bellevue, WA. 98009 13737 SE 26th St. Bellevue, WA. 98005

Toll Free: 800-259-7331 * Phone: 425-746-6310 * Fax: 425-746-6384

www.sgcworld.com * Email: sgc@sgcworld.com

3.3.5.7 Beams

Typically, the radiating element of a beam is a dipole antenna fed with coaxial cable. Connecting a beam to the MAC-200 is accomplished by connecting the coax to positions 3, 4, or 5.

3.3.6 Tips & Tricks

1. The most frequent source of problems in unbalanced antenna systems is the RF Ground. RF grounding is frequently misunderstood and poorly implemented. See our book *The HF User's Guide* available free for download from

<http://www.sgcworld.com/ftp/Books/hfguide.pdf>

2. Be aware of the difference between a SAFETY ground and an RF ground. Safety grounding is necessary to protect your life and property from coming into contact with lethal doses of electricity. RF grounds, when required, are necessary to the operation of your antenna system. Connecting the two together can inject RF into your other electronic equipment.
3. It is a good idea to reserve one SO-239 position on the MAC-200 for a dummy load suitable for initial tune-up on your transceiver.
4. Plan your antenna installation carefully!
5. Don't commit to a final installation until you have tried out your antennas in as near to final form as possible.

PO Box 3526, Bellevue, WA. 98009 13737 SE 26th St. Bellevue, WA. 98005
Toll Free: 800-259-7331 * Phone: 425-746-6310 * Fax: 425-746-6384
www.sgcworld.com * Email: sgc@sgcworld.com

3.3.7 References on Antennas

3.3.7.1 From SGC

SGC, HF User's Guide, available free from

<http://www.sgcworld.com/ftp/Books/hfguide.pdf>

SGC, Stealth Antenna Manual, available free from

<http://www.sgcworld.com/ftp/Books/STEALTHman.pdf>

3.3.7.2 Books

Carr, Joseph, Practical Antenna Handbook, 3rd Edition, McGraw-Hill, New York, 1998.

Hale, Bruce, Editor, The ARRL Handbook, ARRL, Newington, Ct., 1988.

Hall, Gerald, Editor, The ARRL Antenna Book, ARRL, Newington, Ct., 1991

Kleinschmidt, Kirk, Stealth Amateur Radio, ARRL, Newington, Ct., 2001.

PO Box 3526, Bellevue, WA. 98009 13737 SE 26th St. Bellevue, WA. 98005

Toll Free: 800-259-7331 * Phone: 425-746-6310 * Fax: 425-746-6384

www.sgcworld.com * Email: sgc@sgcworld.com

3.4 The Golden Rules of HF Installation

These rules apply to all types of stations, including base, mobile, airborne and marine. They are very important for planning and installing your HF system, if you want to achieve good communications.

1. Install the transceiver as close to the operation site and power supply system as possible (whether it is an external power supply or battery system).
2. The antenna must be installed in an open space and as far as possible from your operating point.
Example: on a sailboat use the backstay as the antenna, since it is the farthest point away from the rest of the vessel.
3. The antenna coupler must be installed at the base of the antenna.
4. Always create your own ground with radial wire or copper straps. They are the only ones that will guarantee a solid and proper ground system.
5. All cables - power supply, control or coaxial - must always be as short as possible and/or necessary. Any excess cable should be shortened to the proper length - never coiled.

Following these rules will minimize marginal installations and problem sources such as RF feedback in the radio, power supply or cables and “hot” or RF burning microphones. If all 5 above points are followed during the design and installation of your HF system, the operator can expect top performance. Further information regarding applications, installation and operation can be downloaded from our website www.sgcworld.com. These publications include:

PO Box 3526, Bellevue, WA. 98009 13737 SE 26th St. Bellevue, WA. 98005
Toll Free: 800-259-7331 * Phone: 425-746-6310 * Fax: 425-746-6384
www.sgcworld.com * Email: sgc@sgcworld.com

- HF User's Guide
- Go Mobile at 500 Watts
- Stealth Antennas
- Smartuner Antenna Coupler Manuals

PO Box 3526, Bellevue, WA. 98009 13737 SE 26th St. Bellevue, WA. 98005

Toll Free: 800-259-7331 * Phone: 425-746-6310 * Fax: 425-746-6384

www.sgcworld.com * Email: sgc@sgcworld.com

4 MAC-200 Operation

4.1 Powering on the MAC-200



Momentarily press the Red Power button on the front panel to activate the MAC-200. You should see the LEDs behind the meter displays light up.

4.1.1 Backlighting

During power on, the MAC-200 checks to see if the AUTO or MANUAL keys are pressed. If the AUTO key is pressed, meter backlighting is turned ON. If the MANUAL key is pressed, meter backlighting is turned OFF. Default from the factory is backlighting ON. The current backlighting settings are stored and will be recovered whenever the MAC-200 is started.

Backlighting can be turned on or off by pressing the **RESET** button and holding the **AUTO** or **MANUAL** key during microprocessor reset.

4.1.2 Keytones

During power on, the MAC-200 checks to see if the 20W or 200W keys are pressed. If the 20W key is pressed, keytones are turned ON. If the 200W key is pressed, keytones are turned OFF. Default from the factory is keytones ON. The current keytones settings are stored and will be recovered whenever the MAC-200 is started.

Keytones can be turned on or off by pressing the **RESET** button and holding the 20W or 200W key during microprocessor reset.

PO Box 3526, Bellevue, WA. 98009 13737 SE 26th St. Bellevue, WA. 98005
Toll Free: 800-259-7331 * Phone: 425-746-6310 * Fax: 425-746-6384
www.sgcworld.com * Email: sgc@sgcworld.com

4.2 Selecting the Meter Range



The meter range selection is made on the two push button switches to the left of the meters. Press the switch labeled 20W to activate a 20 watt range. Press the switch labeled 200W to activate the 200 watt range. No harm will come to the meters if the wrong range is activated for the power applied. When a given range is selected, a small LED will light above the switch to indicate which range is currently selected.

NOTE: SGC does not guarantee 100% calibration of the front panel meters. If an accurate indication of power or SWR is desired, an external meter should be used to develop an instrument calibration table for the front panel meters.

4.3 Selecting the operating antenna

To select an antenna, push the numbered antenna switch on the front panel. A small LED above the switch lights to indicate that it is selected. The selections are:

PO Box 3526, Bellevue, WA. 98009 13737 SE 26th St. Bellevue, WA. 98005
Toll Free: 800-259-7331 * Phone: 425-746-6310 * Fax: 425-746-6384
www.sgcworld.com * Email: sgc@sgcworld.com

Switch Number	Antenna
1	Balanced Antenna
2	Long Wire Antenna
3	Coax 3
4	Coax 4
5	Coax 5



4.4 Auto vs. Manual Antenna Selection

The AUTO and MANUAL buttons control the operation of the microprocessor in selecting an antenna. A small LED over each switch indicates the current operating mode.

In AUTO mode operation the MAC-200 remembers not only the frequency, but the antenna. The tuner will save the selected antenna along with the tuner settings when a successful match is found. Both the tuner settings and the antenna settings will be recalled the next time the MAC-200 is operated at that frequency.

PO Box 3526, Bellevue, WA. 98009 13737 SE 26th St. Bellevue, WA. 98005

Toll Free: 800-259-7331 * Phone: 425-746-6310 * Fax: 425-746-6384

www.sgcworld.com * Email: sgc@sgcworld.com

Antenna settings are kept in a special set of bins. Only one antenna may be stored in each bin. The upper frequency limit on each bin is given in the table below:

Freq (Mhz)
2.836
5.754
8.760
12.653
16.626
19.600
23.488
26.431
30.000
>30.000

NOTE: Actual transition frequencies may vary slightly with temperature and aging.

When changing the selected antenna in AUTO mode, the LED above the AUTO switch will blink for 10 seconds after a new antenna is selected. Transmitting while the LED is blinking will cause the MAC-200 to store the antenna selection in the appropriate bin. If no transmission occurs while the LED is blinking, the MAC-200 will go back to its stored antenna.

When operating in MANUAL mode, the MAC-200 ignores the antenna setting, but the antenna tuner continues to function. Tuner settings will be stored and recalled from memory without changing the antenna selection setting. This may cause retuning when going back to the AUTO mode since the antenna and the tuning settings may no longer match.

Tuner settings are stored in predefined 'bins' across the range of the tuner. The width of each bin varies with frequency, but averages approximately 170 kHz per bin, with more bins at lower frequencies and fewer, wider bins at higher frequencies. Retuning may occur when working at opposite ends of a bin if the change in

PO Box 3526, Bellevue, WA. 98009 13737 SE 26th St. Bellevue, WA. 98005
Toll Free: 800-259-7331 * Phone: 425-746-6310 * Fax: 425-746-6384
www.sgcworld.com * Email: sgc@sgcworld.com

feed point impedance with frequency is particularly high. This will be particularly common with High-Q, narrow bandwidth antennas.

4.5 Front Panel Reset-Lock operation

The LOCK button when engaged (the small LED next to the button is on), tells the coupler to ignore all instructions to tune. It will not react to a change in any sensor. All front panel buttons will be locked out except for the POWER button and the meter range selection buttons.

The RESET function, when pressed, resets all internal relays to a position that connects the transceiver directly to the antenna.

The MAC-200 may be locked in BYPASS mode (straight through to the antenna), by selecting MANUAL, executing a RESET, and then using the LOCK function to lock the coupler.

PO Box 3526, Bellevue, WA. 98009 13737 SE 26th St. Bellevue, WA. 98005

Toll Free: 800-259-7331 * Phone: 425-746-6310 * Fax: 425-746-6384

www.sgeworld.com * Email: sgc@sgeworld.com

4.6 Do-it-Yourself Light Bulb Test

Any time that a transmitter is used, it must be outputting into a load. A load is anything that the output power can be pumped into. If the transmitter is operated without any sort of load connected, the final amplifier stage could become severely damaged. You should never test a transmitter on the air for the first time, if you are unsure about how to operate it, and if you are unsure whether it is working properly. You could create harmful interference to other stations.

To test transmitters without actually operating into an antenna, dummy loads were created. A dummy load is a load that will dissipate the energy from the transmitter instead of emanating it into the ionosphere. Nearly all commercial dummy loads are large oil-filled cans. These dummy loads change the transmitted energy into heat, which is absorbed by the oil. Because different transmitters output different amounts of power, different sizes of dummy loads must be used. Dummy loads for typical amateur powers (<500 watts) are relatively inexpensive and are readily available.

Unfortunately, when you use a can-type dummy load, you can't see "what's happening" with your transmitter. In this case, you can use a light-bulb dummy load to test your transmitter. Here, the light bulb is directly connected to the output of the transmitter and it dissipates the RF energy as light. The light bulb dummy load is more useful than the oil-can type because you can guess how much power is being output, you can see the voice modulate the SSB (the light will flicker with your voice peaks), and you can tune the transmitter for maximum output (if the transmitter is an older model that requires tuning).

Before building or using the light-bulb dummy load, remember that these models typically don't dissipate the transmitter's output

PO Box 3526, Bellevue, WA. 98009 13737 SE 26th St. Bellevue, WA. 98005

Toll Free: 800-259-7331 * Phone: 425-746-6310 * Fax: 425-746-6384

www.sgcworld.com * Email: sgc@sgcworld.com

as well as an oilcan dummy load. The result is that RF will "leak" out; we have heard a few stories of amateurs who were heard around town while operating their transmitters into a light-bulb dummy load. If you use this system, make sure that you test the equipment on a clear, harmless frequency (NEVER test with the transmitter set on an emergency frequency, such as 2182 KHz).

SGC recommends that you build the light-bulb dummy load with the following parts although we have made one with an old light fixture and a makeshift version with just alligator clip leads and a light bulb):

- AC socket to cable with a PL-259 connector (for transceiver)
- AC socket to cable with alligator clips (needed with coupler)
- Light bulb to AC adapter
- 75 to 125 watt light bulb, 120 to 220 VAC
- 100 watt radio transceiver
- Any SGC Smartuner or equivalent

ATTENTION: Some retuning may take place as the impedance of the light bulb varies with the power level. If the power level is held constant with a continuous carrier such as produced by CW mode operation, the coupler setting will settle after a short period of time.

PO Box 3526, Bellevue, WA. 98009 13737 SE 26th St. Bellevue, WA. 98005

Toll Free: 800-259-7331 * Phone: 425-746-6310 * Fax: 425-746-6384

www.sgcworld.com * Email: sgc@sgcworld.com

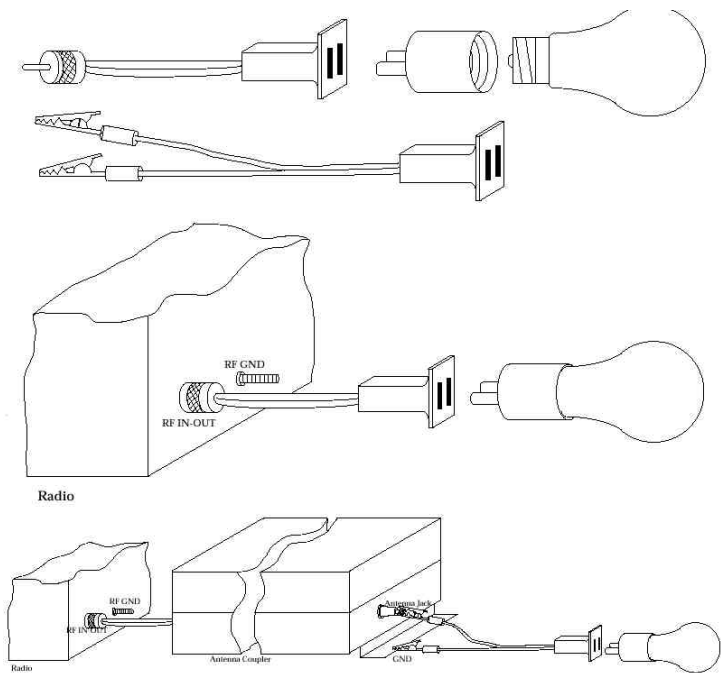

RADIO TEST PROCEDURE

1. Connect the transceiver light bulb load to the radio RF in/out jack.
2. Turn on the radio and set the CW mode.
3. Key the PTT switch on the microphone and look at the light bulb. If the light bulb load is connected and the radio is transmitting, the light should turn on.
4. Set the radio to SSB mode.
5. Key the PTT switch on the microphone and talk into the microphone. Notice that the light turns on when you talk.

PO Box 3526, Bellevue, WA. 98009 13737 SE 26th St. Bellevue, WA. 98005
 Toll Free: 800-259-7331 * Phone: 425-746-6310 * Fax: 425-746-6384
 www.sgcworld.com * Email: sgc@sgcworld.com

COUPLER TEST PROCEDURE

1. Connect the coupler to the radio.
2. Connect coupler light bulb load to Smartuner coupler antenna output.
3. Turn on the radio and the Smartuner coupler.
4. Set the radio to the CW mode.
5. Key the PTT switch on the microphone and look at the light bulb. The light should turn on if the coupler has completed its tuning cycle and if the radio is transmitting.
6. For further testing, follow steps 4 & 5 of the radio test procedure. Note: The light bulb might not turn on immediately if the coupler has not yet been tuned for the frequency of the transmitter. The output power (light-bulb brightness) is greatest when the coupler is properly tuned. This test will ensure that the radio and coupler are working properly.

PO Box 3526, Bellevue, WA. 98009 13737 SE 26th St. Bellevue, WA. 98005

Toll Free: 800-259-7331 * Phone: 425-746-6310 * Fax: 425-746-6384

www.sgeworld.com * Email: sgc@sgeworld.com

5 Theory of Operation

The MAC-200 tuner is built around two basic coupler networks, the L & PI. Note that the L network as viewed from the transceiver may be configured as either “C in” or “C out,” whichever is required by the load. In either case, the end of the network containing the shunt C element will be the higher impedance end of the network.

L Networks:

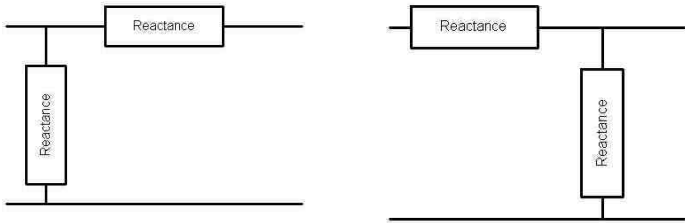

Pi Network

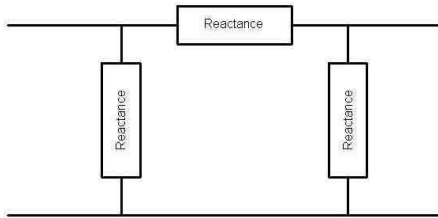

5.1 Tuning Process and Options

The MAC-200 MicroTune™ Software is unique in that it allows precise tuning of the digitally controlled π and L network for a

PO Box 3526, Bellevue, WA. 98009 13737 SE 26th St. Bellevue, WA. 98005
Toll Free: 800-259-7331 * Phone: 425-746-6310 * Fax: 425-746-6384
www.sgeworld.com * Email: sgc@sgeworld.com

wide variety of antennas. The versatile MicroTune™ software offers these special functions:

1. The coupler is activated whenever forward power is present.
2. In addition to sampling VSWR to determine if the coupler should retune, it also does a frequency comparison. This causes the coupler to tune whenever the transmit frequency changes independent of the VSWR reading.
3. Many tuning paths test different antenna situations. The initial tuning of a new frequency (or switched antenna) may require up to two seconds. Any further tuning happens in a matter of milliseconds if jumper JP3 (Tune From Memory) is in its default position.
4. Facilities and algorithms are used which enable accurate tuning at the low end of the frequency band—even on shorter antennas than previously possible.
5. The BITE (Built-In-Test-Equipment) Tune LED includes a safety feature that alerts the operator to a mismatched condition. When the proper conditions for tuning are not present, the BITE indicators will blink. When this happens, the software will “time out” within 20 seconds unless a new frequency is sensed. A new frequency will cause the coupler to attempt a new match.

PO Box 3526, Bellevue, WA. 98009 13737 SE 26th St. Bellevue, WA. 98005
Toll Free: 800-259-7331 * Phone: 425-746-6310 * Fax: 425-746-6384
www.sgcworld.com * Email: sgc@sgcworld.com

5.1.1 Tuning Process

An array of detector devices in the MAC-200 monitor the antenna system impedance, reactance, and the VSWR when RF power is applied. The coupler also monitors forward power, since the control computer requires an indication of both forward and reflected power in order to allow tuning to proceed. The forward power detector is a check to ensure that the measurements made are applied RF and are not spurious signals from the data conversion system. The MAC-200 will tune only when enough forward power is present to confirm this check. After RF is applied to the detector system, it passes through the coupler-tuning array. The coupler-tuning array consists of six capacitors in shunt on the input arm of the network, seven inductors in the series arm, and four more capacitors in shunt on the output arm, all arranged in binary increments. Relays work with each lumped constant and allow removal or entry as desired. A network having 64 values on input shunt C, 16 values of output shunt C, and up to 128 values of series L is possible with the manipulation of these 17 relays.

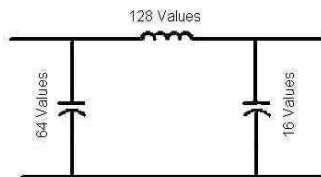

PO Box 3526, Bellevue, WA. 98009 13737 SE 26th St. Bellevue, WA. 98005
Toll Free: 800-259-7331 * Phone: 425-746-6310 * Fax: 425-746-6384
www.sgcworld.com * Email: sgc@sgcworld.com

5.1.2 Impedance Detector

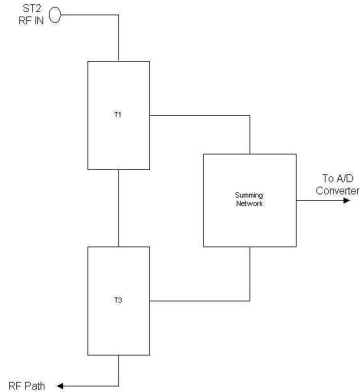

RF transformers T1 and T3 drive the impedance bridge that is balanced at 50 ohms. T3 samples the line current and thus D7 outputs a negative DC level proportional to line current. A tertiary winding on transformer T1 provides a line voltage sample to D2 that provides a positive voltage proportional to line voltage. R18 and R11 act as a summing network for the current and voltage signals, with ratios chosen, such that at 50 ohms, the summed signals result in a balanced or zero voltage condition. If the line impedance goes too high, the signal from the voltage sensor will be relatively higher than the current sensor, which will result in a net positive output voltage from the summing network. Similarly, a low line impedance will result in more output from the current sensor, resulting in a net negative output voltage from the summing network. The summing network output is shifted to a 0 to 5v range, then fed to the processor's A to D converter port, and used within the micro-controller.

PO Box 3526, Bellevue, WA. 98009 13737 SE 26th St. Bellevue, WA. 98005

Toll Free: 800-259-7331 * Phone: 425-746-6310 * Fax: 425-746-6384

www.sgcworld.com * Email: sgc@sgcworld.com

5.1.3 VSWR Detector

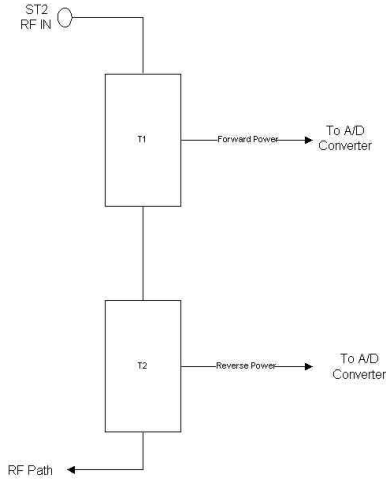

A directional coupler is formed from current transformer T2 and voltage transformer T1, with termination resistors R33, R34, R35, and R36. The coupler is inserted in the 50-ohm transmission line between the input connector, ST2 RF - ST3 GND, and the tuning network. Forward power is measured across R33, R34 and reflected power is measured across R35, R36. Diode D1 generates a positive DC voltage proportional to forward power and D3 generates a positive DC voltage proportional to reflected power. The forward DC output is fed to a voltage divider consisting of R19 and R14. These voltages are input to the RF power detector and to an A to D converter port of the processor. The reflected DC output passes through a voltage divider consisting of R29 and R16, and then goes to an A to D converter port of the processor.

5.1.4 Phase Detector

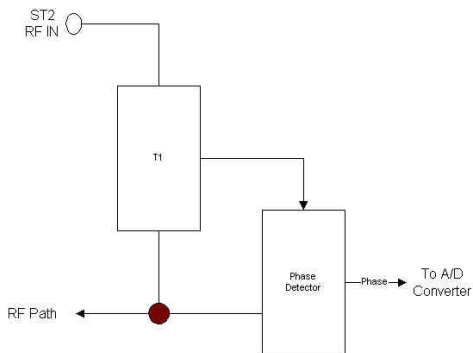

A phase detector consists of T3, A1, and their associated components. This detector indicates the state of any reactance associated with the antenna coupler as noted from the generator. A line current sample is compared in phase with a voltage sample in a double balanced mixer. Output polarity varies negative or positive depending on the reactance of the antenna. The output of the phase detector A1 is shifted to a 0 to 5v range, then fed to the processor's A to D converter port and used within the micro controller.

PO Box 3526, Bellevue, WA. 98009 13737 SE 26th St. Bellevue, WA. 98005

Toll Free: 800-259-7331 * Phone: 425-746-6310 * Fax: 425-746-6384

www.sgcworld.com * Email: sgc@sgcworld.com

5.1.5 Central Processing Unit (CPU)

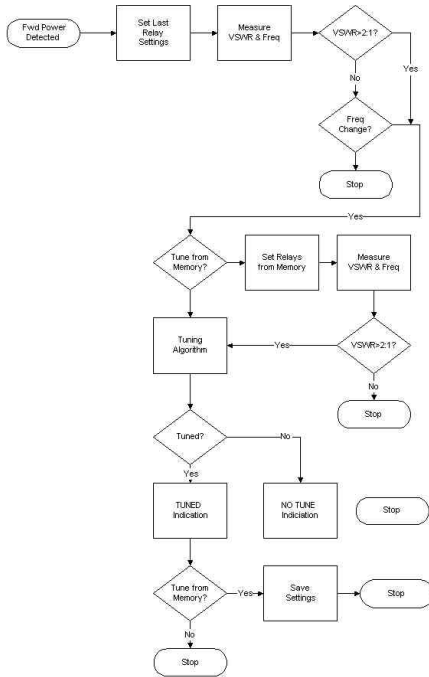

A tune-up algorithm implements antenna matching. It is designed using the MC68HC711E9 microprocessor that features a versatile instruction set, RAM, and EEPROM (memory which is saved after the coupler is turned off).

The antenna coupler relays are controlled by latches U6 and U7, which receive serial data input directly from the CPU, and Q5. During operation, data is transferred into the CPU from the A to D ports and the Input Capture port (measures RF frequency).

The program monitors the status of the input sensors and—starting from a preset condition—uses a built-in algorithm to achieve a

PO Box 3526, Bellevue, WA. 98009 13737 SE 26th St. Bellevue, WA. 98005
Toll Free: 800-259-7331 * Phone: 425-746-6310 * Fax: 425-746-6384
www.sgcworld.com * Email: sgc@sgcworld.com

tuned condition. When the tuning algorithm is complete, the CPU saves the settings in its EEPROM, which is addressed by the applied RF frequency. This non-volatile memory table is the basis of the exclusive learning feature of the MAC-200.

After it has stored and latched the network status, the CPU waits for RF to cease transmitting and returns to the Stop mode. When RF is re-transmitted, the first step in the tuning algorithm is to measure the frequency of the signal passing through the coupler. From the frequency data, the computer then searches its EEPROM for previously stored data. If data is found, it is tested for validity, and the required “end of tune” conditions will be sensed by the RF sensors. Then the data will be latched in place, and the CPU will again wait for RF to cease transmitting and turn to the Stop mode.

This process takes about 10 milliseconds, which is the same length of time that is required to close the network relays.

PO Box 3526, Bellevue, WA. 98009 13737 SE 26th St. Bellevue, WA. 98005

Toll Free: 800-259-7331 * Phone: 425-746-6310 * Fax: 425-746-6384

www.sgcworld.com * Email: sgc@sgcworld.com

5.1.6 Initialization

The microcomputer is usually in the Stop mode and requires an interrupt signal (XIRQ) to start program implementation. The XIRQ comes from the RF detector circuitry. This line, going low, will wake the CPU.

5.1.7 Jumper Settings

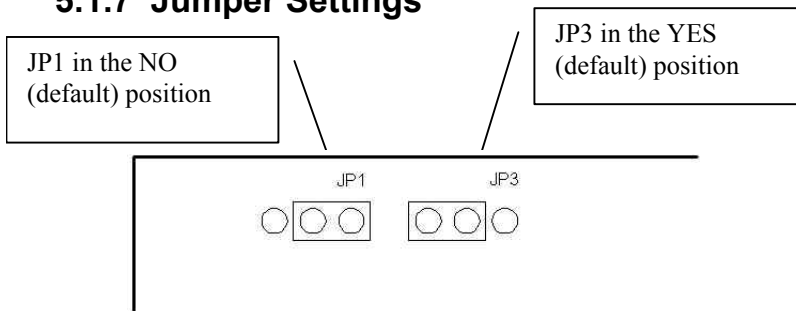

The MAC-200 may be bypassed for broadband (un-tuned antenna) scanning in receive mode. All you need to do is press the reset button or turn power off and on. When the coupler comes back on, the tuning elements remain out of the circuit until the Smartuner is activated by a transmitted signal.

If broad band operation is required during receive for scan operation, jumper JP1 may be set to the Yes position. This will drop the tuning elements out of the circuit on receive only. Jumper JP1 is located adjacent to MCU (U5) along the edge of the printed circuit board. Setting JP1 to the Yes position is recommended if you are using a radio for split band communications, for scanning

PO Box 3526, Bellevue, WA. 98009 13737 SE 26th St. Bellevue, WA. 98005
Toll Free: 800-259-7331 * Phone: 425-746-6310 * Fax: 425-746-6384
www.sgeworld.com * Email: sgc@sgeworld.com

selective calling protocols, or for Automatic Link Establishment (ALE). The default is: Tuning Out In Rcv: [NO].

Jumper JP3 bypasses the coupler's memories. This means that each time the coupler is used on a different frequency, it will retune rather than use previously stored information. The default is: Tune From Memory: [YES].

5.1.8 Program Description

When DC power is applied, the computer initializes the processor registers in accordance with the hardware. All tuning elements are then removed and the 'tune' indicators are turned off. At this time the computer reverts to a "sleep" mode awaiting RF power.

PO Box 3526, Bellevue, WA. 98009 13737 SE 26th St. Bellevue, WA. 98005
Toll Free: 800-259-7331 * Phone: 425-746-6310 * Fax: 425-746-6384
www.sgcworld.com * Email: sgc@sgcworld.com

5.1.8.1 Auto Mode

In the Auto Mode, the MAC-200 will select the proper antenna as well as the proper tuning settings for the antenna from memory if possible.

Detecting forward power. Once forward power is detected and IF the MAC-200 is switched to AUTO, the current coupler settings are sent to the relays and the proper antenna is chosen for operation. Next, the VSWR is checked and the frequency measured. If the VSWR is greater than 2:1 or a difference in frequency is detected, the program branches to the re-tune program. If it is determined that the VSWR is less than 2:1 and the frequency has not changed, the computer returns to the Stop mode.

Retuning. Once it is determined that retuning is necessary, a test is made to see if JP3 is set to tune from memory. If the result is re-tuning from memory, settings are recalled from the EEPROM based on the frequency measured. The recalled data is then tested for validity. If the data proves invalid, it is bypassed and retuning is performed. If the data recalled proves valid, the data is sent to the relays and the VSWR is checked. If the VSWR is less than 2:1, the program branches to the “OK Tuned” section of the program. If the VSWR is found to be greater than 2:1, the program branches to the “re-tune” program.

Selecting tuning path. Several tests are made to determine which tuning algorithm or path should be used to tune the coupler. These tests are based on frequency, antenna input impedance, antenna phase, and VSWR. Numerous subroutines are executed repeatedly, depending on the status of the criteria mentioned above, in order to achieve proper tuning.

Signaling “no-tune.” Should the initial primary tuning sequence prove unsuccessful, secondary algorithms are attempted until all possible routines have been exhausted. If, after the secondary attempts, the coupler still cannot achieve a proper VSWR, the program branches to a “no-tune” program. Here, the LED’s and remote tune indicator will blink on and off for about 15 seconds to tell the user a proper VSWR could not be found. After the indicators stop blinking, the program waits for forward power to cease (if it has not ceased already) and returns to stop mode. At this point the user should try several other frequencies. If the “no-tune” condition persists, check the installation of the antenna, coupler, radio, and ground system for possible problems.

Signaling “OK tune.” If the coupler achieves a good VSWR during the tuning sequence, the program branches to the “OK Tune” section of the code. Here, the tune indicators are engaged. A test is then made to check if JP3 is set to tune from memory. If so, the frequency is measured and the tuning elements used are saved in memory coupled with a verification code. Once saved, a test is made on JP1 to check if the duplex mode has been selected. If so, the transmit tuning elements remain in circuit until the receive mode is verified. At this time, all tuning elements are removed. The frequency is then saved for future comparison and the CPU reverts back to the STOP mode.

PO Box 3526, Bellevue, WA. 98009 13737 SE 26th St. Bellevue, WA. 98005

Toll Free: 800-259-7331 * Phone: 425-746-6310 * Fax: 425-746-6384

www.sgcworld.com * Email: sgc@sgcworld.com

5.1.8.2 Manual Mode

When the MAC-200 is operating in manual mode, antenna selection is made from the front panel switches.

5.1.9 Tuning Paths

As mentioned previously, various tests are executed to determine the most logical tuning sequence to be performed. Dependent on the test results, additional tests and appropriate subroutines are executed throughout the tuning process. Following are examples of the activity that occurs when the coupler must be matched to a frequency that requires a slightly longer or shorter antenna:

5.1.9.1 Antenna Too Short

Once the coupler has verified RF power, tuning sequence proceeds as follows:

1. Series inductance is added until the phase is deemed as being inductive.
2. At this point it is normal for the input impedance to be low.
3. Input capacitance is added until the antenna is no longer inductive.
4. The program will continue to increment the series inductance in .125 μH steps—each time normalizing

PO Box 3526, Bellevue, WA. 98009 13737 SE 26th St. Bellevue, WA. 98005
Toll Free: 800-259-7331 * Phone: 425-746-6310 * Fax: 425-746-6384
www.sgcworld.com * Email: sgc@sgcworld.com

the input impedance with input capacitance until a low VSWR is measured of less than 2:1. This process will continue until the VSWR has climbed back to higher than 2:1 or the impedance has become high.

5. The settings that gave the lowest VSWR have been kept in memory and are now recalled to verify it is a low VSWR
6. At this point the tune indicators are engaged. The current relay data is saved if JP3 is set to tune from memory; if JP1 is set to tune elements out during receive position, the program waits until forward power is no longer present, then removes all tuning elements. The frequency is saved for future frequency comparison, and the computer reverts to Stop mode.

PO Box 3526, Bellevue, WA. 98009 13737 SE 26th St. Bellevue, WA. 98005

Toll Free: 800-259-7331 * Phone: 425-746-6310 * Fax: 425-746-6384

www.sgcworld.com * Email: sgc@sgcworld.com

5.1.9.2 Antenna Too Long

Once the coupler has verified RF power, the tuning sequence proceeds as follows:

1. Output capacitance is added until the phase switches to capacitive.
2. At this point, series inductance is added until the antenna is no longer capacitive.
3. Fine tuning is performed by trying a small amount of input capacitance (this may or may not be required).
4. At this point, the program executes the same as step 5 (antenna too short).

This is a simplified program flow based on two possible antenna conditions. Much more complex tuning is normally the case. Further detailed description, however, is beyond the scope of this manual.

5.1.9.3 JP1 – Tuning Elements Out during Receive

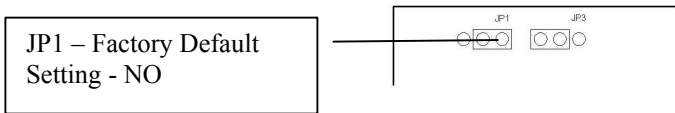

YES - In this position the software will retain data required in transmit to match the coupler while removing all tuning elements when no forward power is detected.

PO Box 3526, Bellevue, WA. 98009 13737 SE 26th St. Bellevue, WA. 98005
Toll Free: 800-259-7331 * Phone: 425-746-6310 * Fax: 425-746-6384
www.sgeworld.com * Email: sgc@sgeworld.com

NO - In this position the coupler will keep the required tuning data and will change nothing whether in receive or transmit.

If typical operation is out of band duplex, **Yes** would be most likely to give better performance. If in band operation is typical and duplex or simplex is the predominant mode of operation, then **No** is usually the better choice.

5.1.9.4 JP3 – Tune from Memory

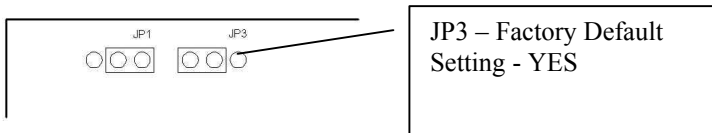

YES - In this position the coupler will recall data previously saved and try this data before attempting to re-tune. If the data is valid and the VSWR is less than 2:1 the tune is completed. In this position the coupler will save any new data in its memory for any frequency. A new frequency must first be learned, while in this mode, before it can be recalled.

NO - In this position, the coupler will not use previously saved tuning data. Each time a different frequency is selected, the coupler will proceed through a complete tuning sequence. Clearly, the advantage of **Yes** is speed. The coupler will seem to be matched instantly when in this position, if the frequency being used has previously been saved in EEPROM. Disadvantages include a difference in frequency too small for the computer to detect. This would result in recall of valid data that may not necessarily present

PO Box 3526, Bellevue, WA. 98009 13737 SE 26th St. Bellevue, WA. 98005

Toll Free: 800-259-7331 * Phone: 425-746-6310 * Fax: 425-746-6384

www.sgcworld.com * Email: sgc@sgcworld.com

the best match. We suggest starting with JP3 in the **Yes** position. If operation is as expected, don't change it.

5.1.10 Internal B.I.T.E.* LEDs

*Built In Test Equipment

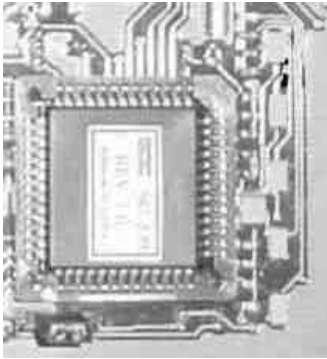

FRONT

FWD

PHZ

2:1

L'Z'

TND

TND

This LED will light when the tuner has found an acceptable match. It will remain lit until conditions have changed which will cause the tuner to find a different match. (i.e. A new transmit frequency has been detected, or tuner has been reset.)

L'Z'

This LED shows the status of the antenna impedance. When lit, the impedance is 50 ohms or less. When off, the impedance is greater than 50 ohms.

PO Box 3526, Bellevue, WA. 98009 13737 SE 26th St. Bellevue, WA. 98005
Toll Free: 800-259-7331 * Phone: 425-746-6310 * Fax: 425-746-6384
www.sgcworld.com * Email: sgc@sgcworld.com

2:1

This LED will light when the VSWR is greater than 2:1. It will go out when VSWR is less than 2:1.

PHZ

This LED indicates the status of the antenna reactance. When lit, reactance is inductive. When off, reactance is capacitive.

FWD

This LED indicates the presence or lack of RF power from the radio. When transmitting, the LED will light to indicate RF detected. The LED should be dark when receiving.

OTHER

All LEDs will blink on and off at a rate of 2Hz to indicate the tuner was not able to find a valid match.

Note that these status LEDs are usually used to aid a technician in diagnosing the status of the antenna system and should not be thought of as laboratory instruments. As the Smarttuner tunes, the BITE status will be continually updated from the CPU.

PO Box 3526, Bellevue, WA. 98009 13737 SE 26th St. Bellevue, WA. 98005

Toll Free: 800-259-7331 * Phone: 425-746-6310 * Fax: 425-746-6384

www.sgcworld.com * Email: sgc@sgcworld.com

5.2 Schematics

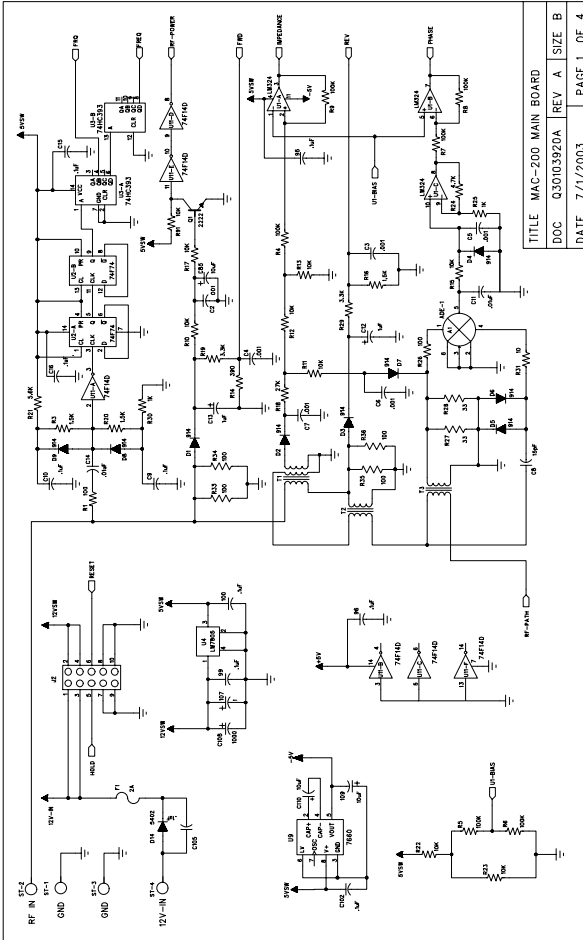

TITLE	MAC-200 MAIN BOARD
DOC	Q30103920A
REV	A
SIZE	B
DATE	7/1/2003
PAGE	1 OF 4

PO Box 3526, Bellevue, WA. 98009 13737 SE 26th St. Bellevue, WA. 98005
 Toll Free: 800-259-7331 * Phone: 425-746-6310 * Fax: 425-746-6384
 www.sgcworld.com * Email: sgc@sgcworld.com

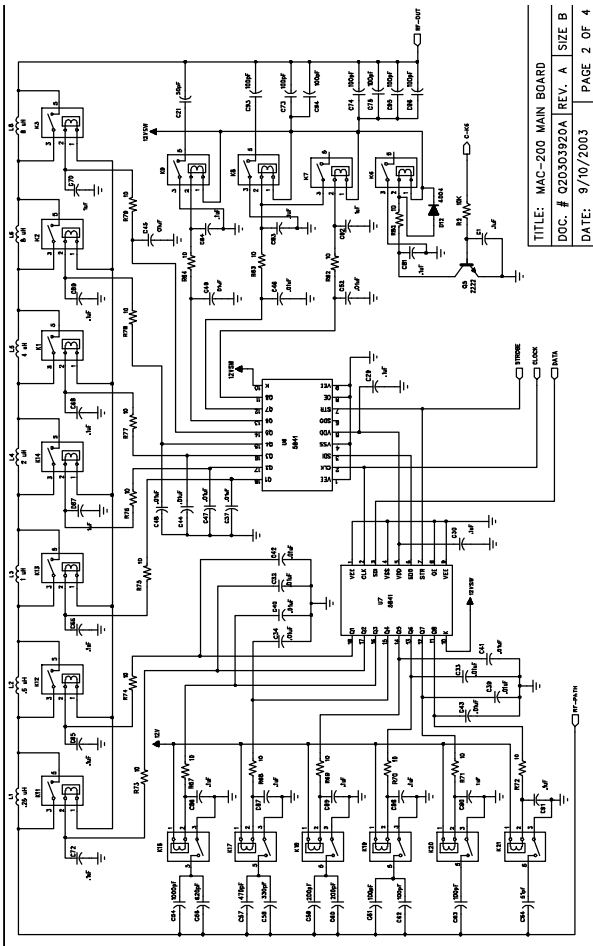

TITLE: MAC-200 MAIN BOARD
DOC. # Q20303920A REV. A SIZE B
DATE: 9/10/2003 PAGE 2 OF 4

PO Box 3526, Bellevue, WA. 98009 13737 SE 26th St. Bellevue, WA. 98005
 Toll Free: 800-259-7331 * Phone: 425-746-6310 * Fax: 425-746-6384
 www.sgcworld.com * Email: sgc@sgcworld.com

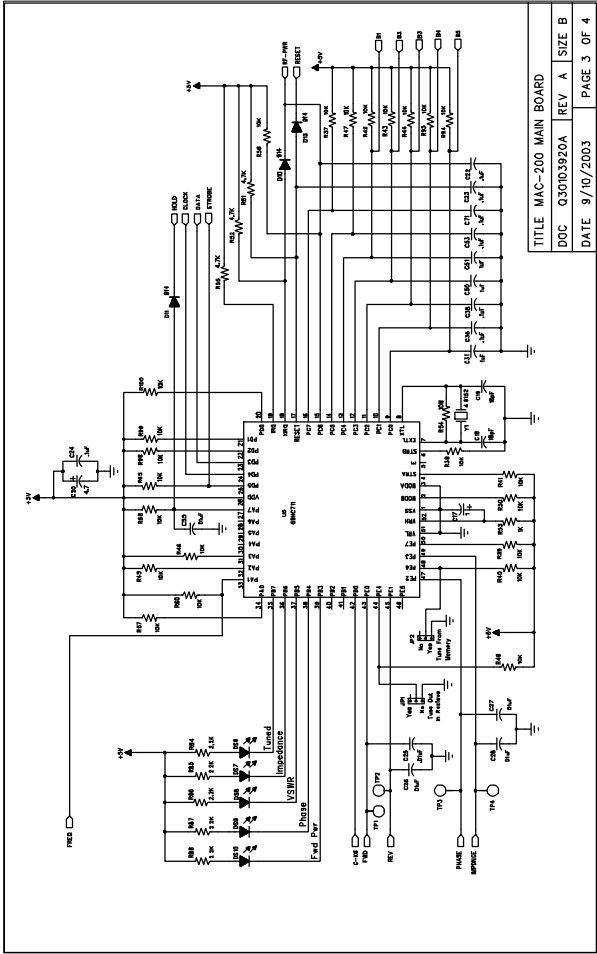

TITLE MAC-200 MAIN BOARD		
DOC Q30103920A	REV A	SIZE B
DATE 9/10/2003		PAGE 3 OF 4

PO Box 3526, Bellevue, WA. 98009 13737 SE 26th St. Bellevue, WA. 98005
Toll Free: 800-259-7331 * Phone: 425-746-6310 * Fax: 425-746-6384
www.sgcworld.com * Email: sgc@sgcworld.com

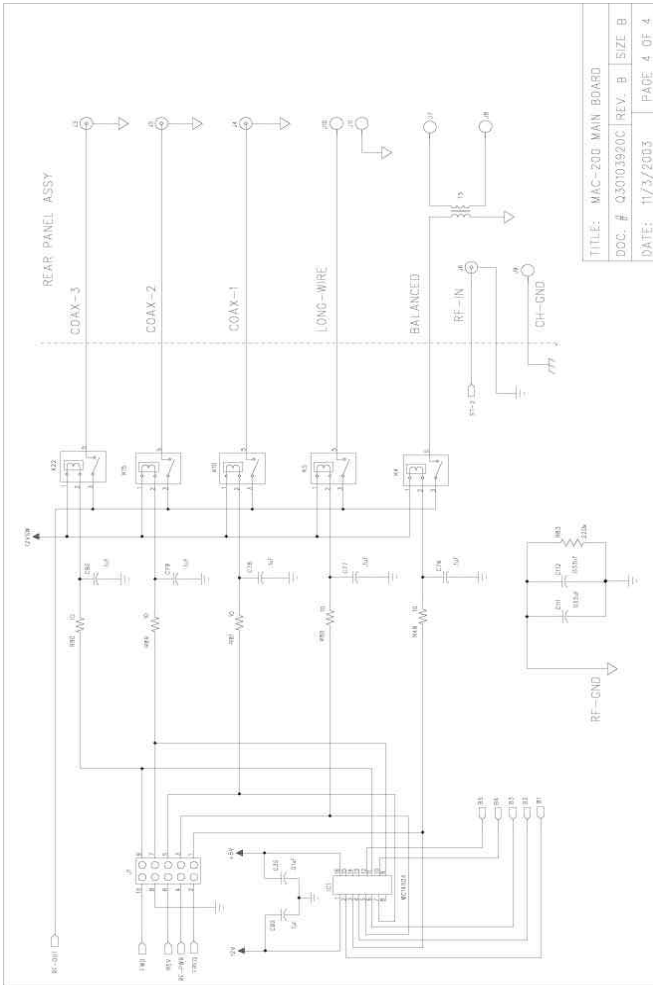

TITLE: MAC-200 MAIN BOARD	SIZE: B
DOC. # Q30703920C	REV. B
DATE: 11/3/2003	PAGE 4 OF 4

PO Box 3526, Bellevue, WA. 98009 13737 SE 26th St. Bellevue, WA. 98005
 Toll Free: 800-259-7331 * Phone: 425-746-6310 * Fax: 425-746-6384
 www.sgcworld.com * Email: sgc@sgcworld.com

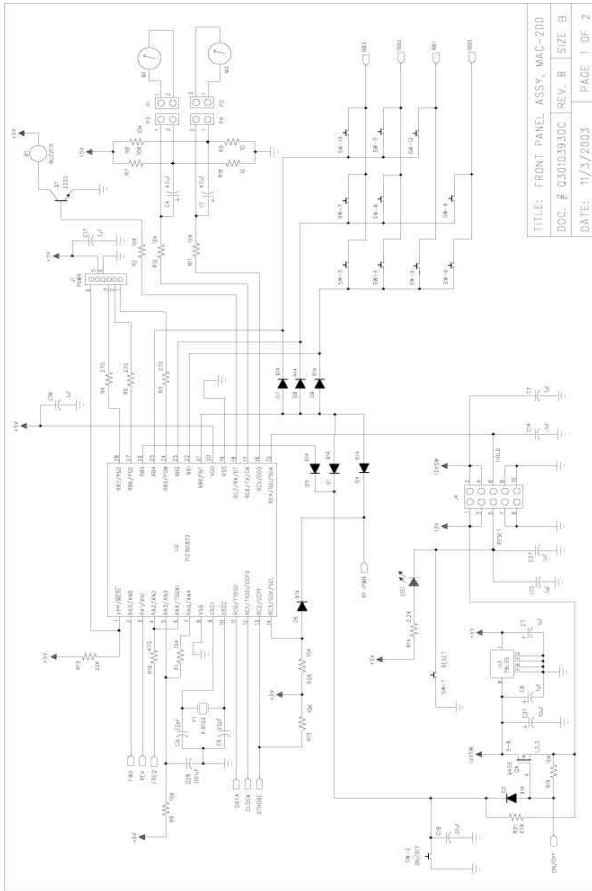

TITLE: FRONT PANEL ASSY, MAC-200
 DOC. # Q30D3930C REV. B | SIZE B
 DATE: 11/3/2003 PAGE 1 OF 2

PO Box 3526, Bellevue, WA. 98009 13737 SE 26th St. Bellevue, WA. 98005
 Toll Free: 800-259-7331 * Phone: 425-746-6310 * Fax: 425-746-6384
 www.sgcworld.com * Email: sgc@sgcworld.com

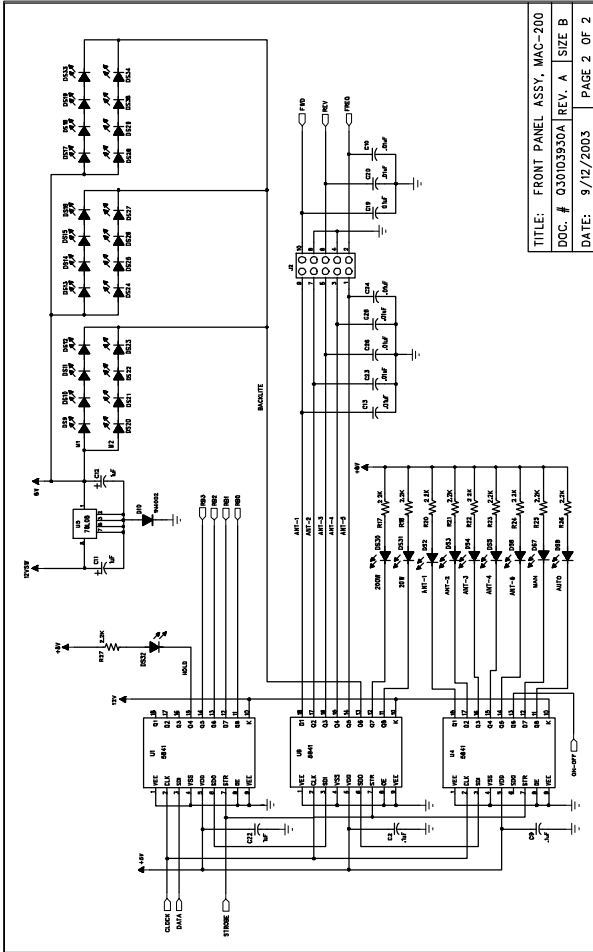

TITLE: FRONT PANEL ASSY, MAC-200	SIZE B
DOC. # 030103930A	REV. A
DATE: 9/12/2003	PAGE 2 OF 2

PO Box 3526, Bellevue, WA. 98009 13737 SE 26th St. Bellevue, WA. 98005
 Toll Free: 800-259-7331 * Phone: 425-746-6310 * Fax: 425-746-6384
 www.sgcworld.com * Email: sgc@sgcworld.com

5.3 Component Location

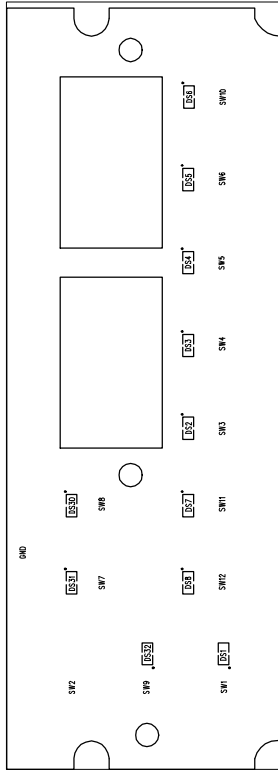

PO Box 3526, Bellevue, WA. 98009 13737 SE 26th St. Bellevue, WA. 98005
Toll Free: 800-259-7331 * Phone: 425-746-6310 * Fax: 425-746-6384
www.sgcworld.com * Email: sgc@sgcworld.com

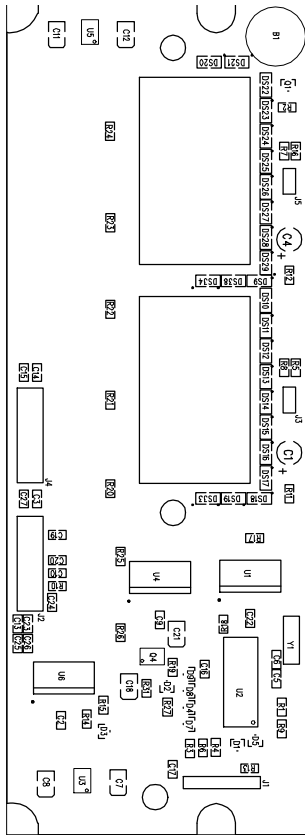

PO Box 3526, Bellevue, WA. 98009 13737 SE 26th St. Bellevue, WA. 98005

Toll Free: 800-259-7331 * Phone: 425-746-6310 * Fax: 425-746-6384

www.sgcworld.com * Email: sgc@sgcworld.com

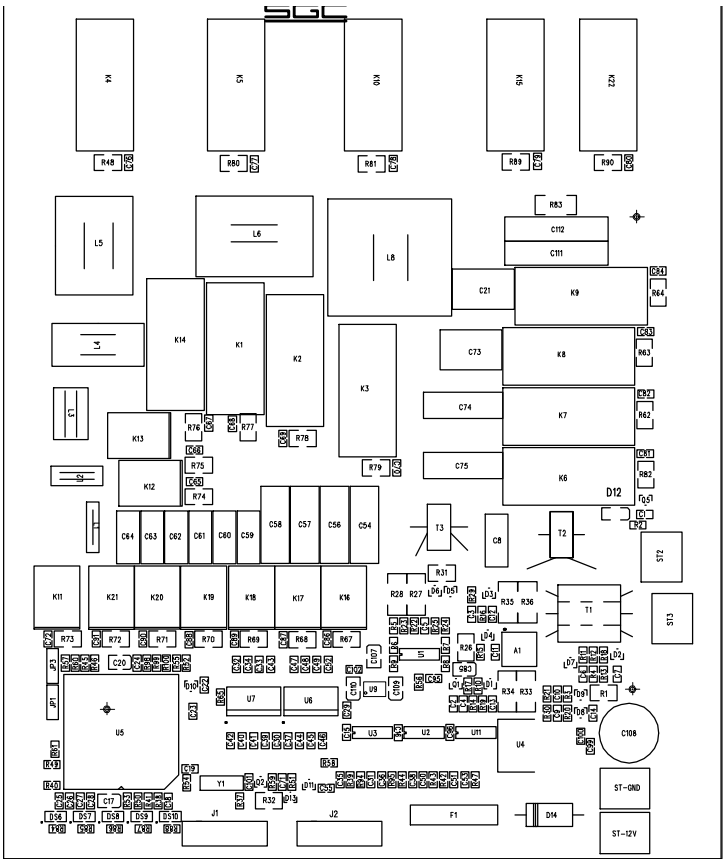

PO Box 3526, Bellevue, WA. 98009 13737 SE 26th St. Bellevue, WA. 98005
 Toll Free: 800-259-7331 * Phone: 425-746-6310 * Fax: 425-746-6384
 www.sgcworld.com * Email: sgc@sgcworld.com

**SGC LIMITED PRODUCT WARRANTY
(1 Year Parts and Labor)
And SOFTWARE LICENSE**

You have purchased an SGC product together with a license to use the software installed in that product. Please return the warranty registration card that accompanies this product, so that we can assure that you receive proper warranty service and important notices that may affect the product. This SGC product is warranted to be free from defects in workmanship and material for a period of 1 year from the original buyer's date of purchase. In the event of a defect, malfunction or failure of which SGC receives notice during the 1 year period, SGC, at its' option, will repair or replace the product free of charge to the buyer. The buyer must contact SGC for a Return Material Authorization Number (RMA) and deliver the product back to SGC with this RMA number and written proof as to date of purchase. SGC will ship a new or repaired product to the buyer, reserving discretionary right to return a newer model that offers at least equal performance. The foregoing warranty extends to the original buyer and does not include a) buyer's cost to return the product to SGC, b) buyer's costs to remove or reinstall the product for warranty work, or c) added costs of special expedited shipment that may be requested by buyer. Except for the limited warranty stated above, and to the full extent permitted by law, SGC disclaims any other express or implied warranties and liability for any incidental, consequential, special or exemplary damages in connection with its product, even if SGC or its agents are advised that such damages are foreseeable. (Note: Some states do not allow the exclusion or limitation of incidental or consequential damages, so the above exclusion may not apply to you). There is no warranty with respect to a) the product's transmission range or geographical coverage that can vary by location b) non-performance caused by using an inadequate or improper antenna or grounding system or c) routine maintenance, periodic adjustment and performance testing of the product or system. SGC customarily charges a flat fee for repairs performed outside of the warranty coverage. To inquire about such charges, please contact SGC.

END USER SOFTWARE LICENSE

SGC warrants that the SOFTWARE included in this product will perform in substantial accordance with the documentation. SGC grants to the original end user of its product a non-exclusive worldwide license to operate the software installed therein. This license shall be transferred to any person or entity that subsequently acquires lawful ownership of the product. This license shall be limited to using the software for contemplated operation of SGC's product. This license does not permit any end user to a) modify or adapt SGC's software or to merge it into another program b) reverse engineer, disassemble, or otherwise attempt to discover SGC's software source code or c) sub license or otherwise transfer SGC's software for any use other than operating the product originally purchased from SGC.

PO Box 3526, Bellevue, WA. 98009 13737 SE 26th St. Bellevue, WA. 98005
Toll Free: 800-259-7331 * Phone: 425-746-6310 * Fax: 425-746-6384
www.sgcworld.com * Email: sgc@sgcworld.com



A Perfect Complement to the MAC-200 The SG-200



Use it at your base with the MAC-200 or in your backpack or travel bag. The SG-200 goes where you want to go!

Specifications

Operating Modes	USB, LSB and CW
Frequency Range	1.8-29.7 MHz
Dimensions	7.25"L x 6"W x 2.75"H 18.5cm x 15cm x 7cm
Approximate Weight	4.5 lbs. (2kg)
DC Voltage	10-18 VDC
Total current (receive)	Typical 400mA
Transmitter power	Adjustable from 0-20W PEP

All the Power you'll need for base, backpack or business travel

© 2003 SGC Inc.

PO Box 3526, Bellevue, WA. 98009 * 13737 SE 26th St. Bellevue, WA. 98005

Toll Free: 800-259-7331 * Phone: 425-746-6310 * Fax: 425-746-6384

www.sgeworld.com * Email: sgc@sgeworld.com