

Heathkit of the Month:  
by Bob Eckweiler, AF6C



**Heathkit HD-1420  
VLF Converter**

**Introduction:**

Many amateur radio enthusiasts started with the hobby of shortwave listening (SWLing). Listening to hams converse together around the world created a strong desire to 'join in' for many SWLers. In the fifties most ham receivers were general coverage, receiving from 530 KHz through 30 or even 40 MHz. The sixties and seventies saw the birth of ham equipment that was specific to the ham bands and many hams kept secondary general coverage receivers to continue listening to the non-ham activities on the HF band. During the eighties transceivers began to include general coverage reception of the HF band, allowing hams once again to use their ham equipment for the added hobby of SWLing.

But what about the frequencies below the broadcast band? Most HF receivers don't cover these frequencies. Table One shows the frequency bands from the HF band down.

Notice that each band covers one decade (except for the lowest band). The 160 meter ham band and the AM broadcast band are really in the MF band. Though these bands are well des-

igned, VLF has come to more generally mean the whole radio frequency spectrum below the broadcast band in SWL circles. Hence the VLF in the name for the Heathkit HD-1420 which covers the frequencies between 10 and 500 KHz.

**The Heathkit HD-1420 VLF Converter:**

The HD-1420 is a converter that takes signals in the range of 10 KHz to 500 KHz and converts them to the 80 meter ham band - specifically 3.510 to 4.000 MHz. It will work with any receiver that covers the 75/80 meter ham band.



The converter is built into a small 5-1/8" x 5-1/8" x 2-1/4" cabinet and weights just one pound. The front of the cabinet has only an LED pilot light and an **OFF - ON** slide switch. The back contains two female UHF connectors marked **Antenna** and **Out**, a power connector for external power, and a ground post. The converter uses an internal 9V battery (NEDA 1604). When the **OFF - ON** switch is in the off position the battery is disconnected and the **Antenna** input is bypassed directly to the **Out** connector. The external power connector is a female 1/8" phone connector, which is an in-

Band	Wavelength	Frequency	Band Nomenclature
HF	100 - 10 meters	3 MHz - 30 MHz	High frequency
MF	1K - 100 meters	300KHz - 3 MHz	Medium Frequency
LF	10K - 1K meters	30 KHz - 300 KHz	Low Frequency
VLF	100K - 10K meters	3 KHz - 30 KHz	Very Low Frequency
ELF	Above 100K meters	Below 3KHz	Extremely Low Frequency

**Table One**

interesting choice as it is easy to short the mating power plug when hot-plugging (inserting or removing the plug with power connected to the plug from the power source). Some sort of external current limiting should be used if the unit is being powered from a high current power or battery supply. External power requirements are 6 to 14 volts DC at a nominal 20 ma. Heath sold a wall-wart battery eliminator, the PS-2350, for \$7.95 that runs the HD-1420 as well as other small Heathkit products.

The Heathkit HD-1420 was introduced in 1986. It remained in production until late 1991. The kit cost \$49.95. It is styled in the brown color of later Heath ham equipment, with white lettering and the Heathkit logo in red. This is the same style as the popular HW-9 QRP transceiver and its accessories.

It's too late to buy a Heathkit VLF converter new. However used ones show up on eBay and at swap-meets occasionally. Palomar manufactures a VLF converter and numerous homebrew designs are available on the web.

### The Circuit:

Figure 1 is a block diagram of the Heathkit HD-1420 VLF converter. When on, the signal from the antenna is fed to a low-frequency RF amplifier that uses a general purpose 2N3904 bipolar transistor. The amplifier has a sensitivity of 1 to 5  $\mu$ V, which is quite adequate for the inherent noise on the low bands. The amplifier is followed by a seven-pole low-pass filter that removes the strong broadcast signals that can play havoc if they reach the mixer stage as well as any regular 75/80 meter signals. A crystal oscillator generates a 3.5 MHz injection signal for the mixer. The oscillator uses an MPF-105 JFET. The amplified signal and the 3.5 MHz injection frequency are mixed in an MC-1496 balanced modulator IC. The output of the modulator is a band of signals between 3.510 and 4.000 MHz that is the converted 10 to 500 KHz frequency band and represents the sum of the band and the 3.5 MHz injection frequency. The balanced modulator has another output

that is the difference between the input band and 3.5 MHz (3.490 to 3.000 MHz) that is also present at the output. Normally these signals are rejected by the tuning of the receiver.

### What's Below 500 KHz?

So what is there to listen to below the broadcast band? Kevin Carey, WB2QMY is the author of a book titled *Listening to Longwave - The World Below 500 Kilohertz* \*. In it he describes what you can hear on these frequencies by band section. Below the broadcast band you will find numerous navigational aids including non-directional beacons (NDBs), military FSK and CW (highly encrypted) used for blanket global coverage, differential GPS data, WX info, ship calling frequencies, and - yes - hams and unlicensed, but legal, hobbyists.

Radio hams are active below 500 KHz. Experimental ham stations operate at 73 KHz, 136 KHz and in the 160 - 190 KHz free band. Be sure to check the rules before transmitting on any of these bands. Special licenses are often required, and there are power and antenna restrictions. Check the ARRL and FCC websites for the latest rules. The 160 - 190 KHz band allows non-licensed operation under FCC part 15 rules. Here you will find hobbyist beacons, coherent CW and even BPSK experimentation; many of these stations are operated by licensed hams.

The NIST WWVB time signal that synchronizes those "atomic clocks" can be found at 60 KHz. Don't expect to hear anything like WWV on the HF bands however; WWVB is strictly an amplitude and phase modulated carrier that is modulated at a one hertz rate.

At, and slightly above, 500 KHz are additional signals. 500 KHz was, for a long time, a maritime distress frequency. While it has been replaced by newer systems (namely GMDSS - Global Maritime Distress Safety System) and is no longer required to be monitored by maritime law, it is still sometimes used as a calling frequency to establish other ship communica-

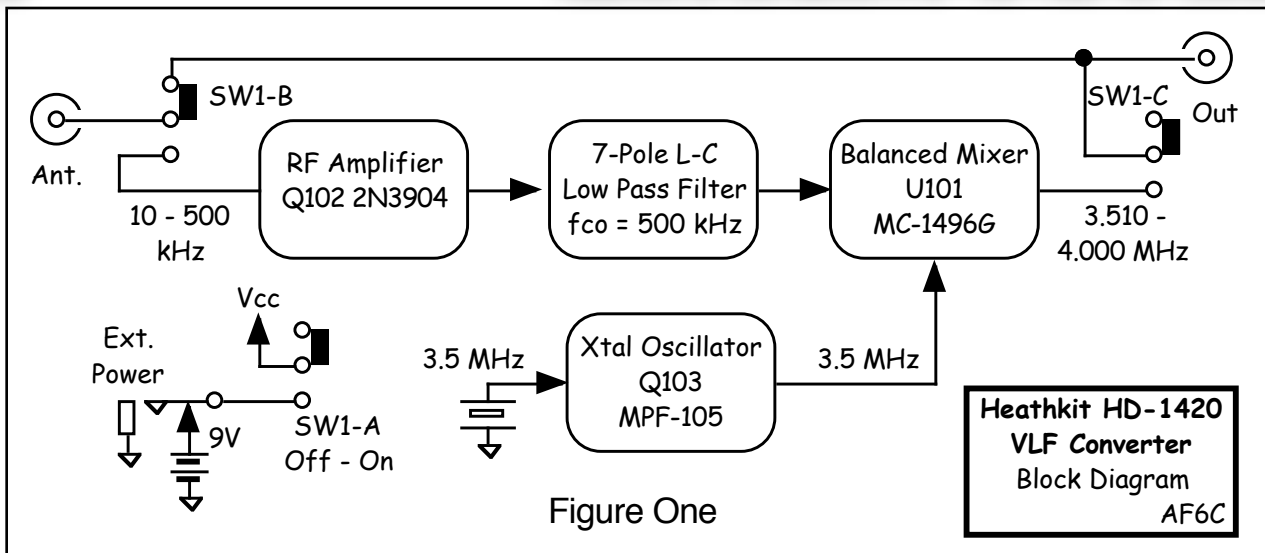

tions. NAVTEX (Navigational Telex) operates on 518 KHz using the equivalent of ham radio's AMTOR mode. It is a weather and bulletin service transmitted by the US Coast Guard. To tune up to this frequency you may need to use a receiver that covers up to 4.02 MHz. Locally NAVTEX operates from Long Beach, CA; Cambria, CA; and Pt. Reyes, CA. A schedule of transmitting times can be found by searching for NAVTEX on Google.

Between 190 and 435 KHz are numerous non-directional beacons - NDBs. These are used for direction finding by ships and airplanes. Older airway beacons are mostly gone today, but many NDB beacons still remain, especially those associated with Instrument Landing Systems. On 337 KHz a beacon sending **NA** marks the approach end of runway 19R at Orange County's John Wayne airport. Other local beacons are: **CPM** (Compton) at 378 KHz, **EMT** (El Monte) at 359 KHz and **SB** (Petis) at 397 KHz, just to name a few.

### Conclusion:

The Heathkit HD-1420 VLF Converter does all it is supposed to do. Sensitivity is such that the typical band QRM and QRN are the limiting factors in receiving signals. Serious VLF SWL'ers often build low-frequency loop antennas to reduce interference and noise. Man-made pulse noise is often present at these frequencies so a receiver with a good noise

Copyright 2009 - 2010, R. Eckweiler & OCARC, Inc.

blanker is a must. I've used the converter with my Kenwood TS-440S transceiver (you have to be careful not to transmit through the device), my old Heathkit SB-301 tube receiver, a fifties Collins 51J4 receiver and a Kenwood R-2000 general coverage receiver. All the local beacons could be heard as well as some DX and unknown ones. Trying to identify them can be a fun challenge, though today's Internet provides a lot of lists. Many hours of enjoyment can be had finding identifying and listening to signals that hide below the AM broadcast band.

**\*Listing to Longwave - The World Below 500 Kiloherz.** By Kevin Carey - WB2QMY. Published by: Universal Radio Research, 2007.

73, from AF6C



*Remember if you come across any old Heathkit Manuals or Catalogs that you do not need, please pass them along to me.*

*Thanks - AF6C*

*This article originally appeared in the month year issue of RF, the newsletter of the Orange County Amateur Radio Club - W6ZE.*