

AH-7000

SUPER WIDEBAND
OMNIDIRECTIONAL ANTENNA

NOTE: Numbers in the circles indicate the order of installation.

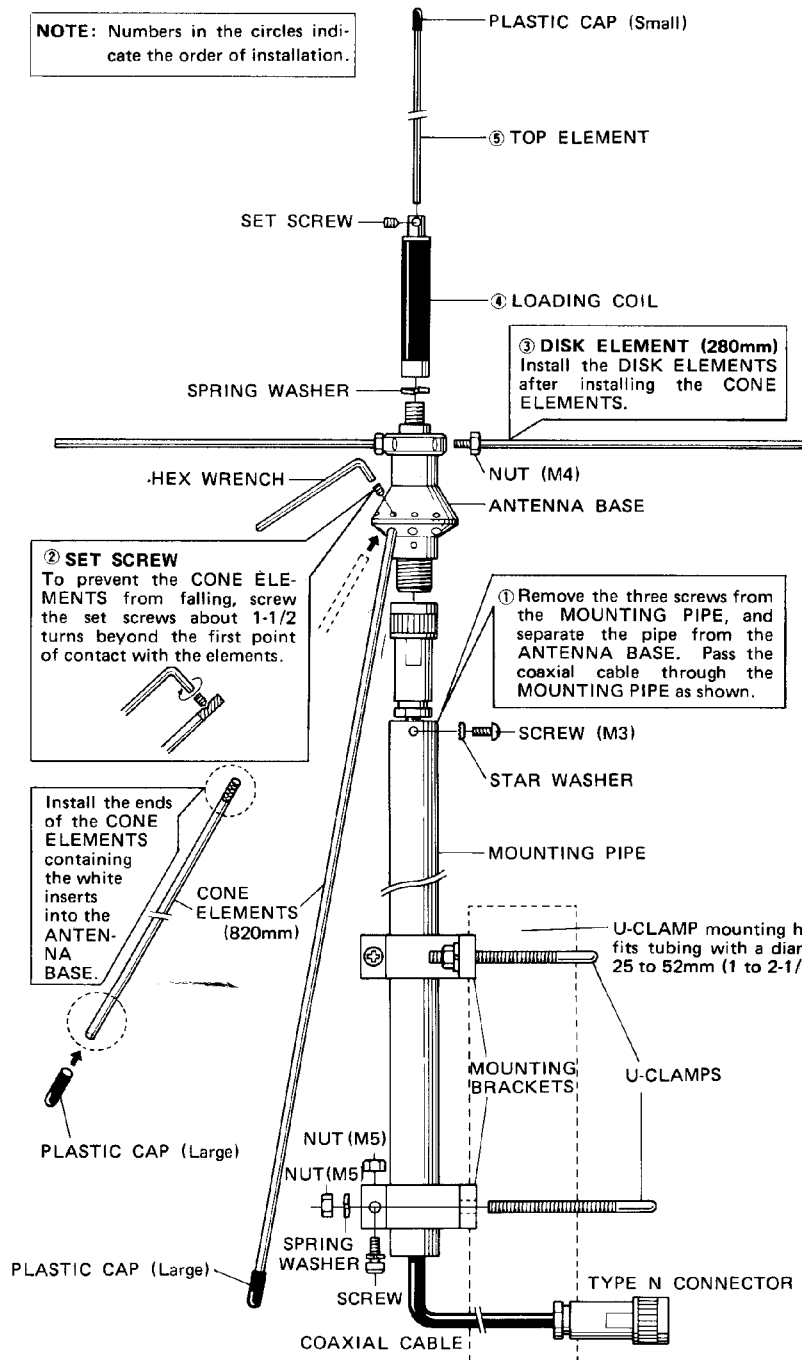

SPECIFICATIONS

Frequency coverage	Receive : 25 to 1300MHz
	Transmit : 50, 144, 430, 900, 1200MHz bands
Input power rating	: 200 watts
Input impedance	: 50 ohms
Supplied connectors	: Type N
Supplied coaxial cable	: 5D-2V (50 ohm)
Type of antenna	: Discone
Length	: 1.7 meters
Weight	: 1kg

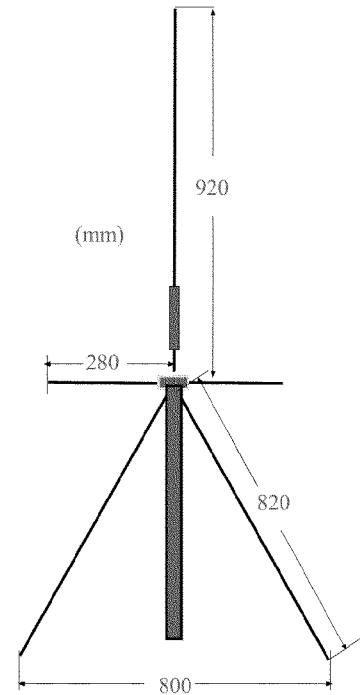

NOTE: Numbers in the circles indicate the order of installation.

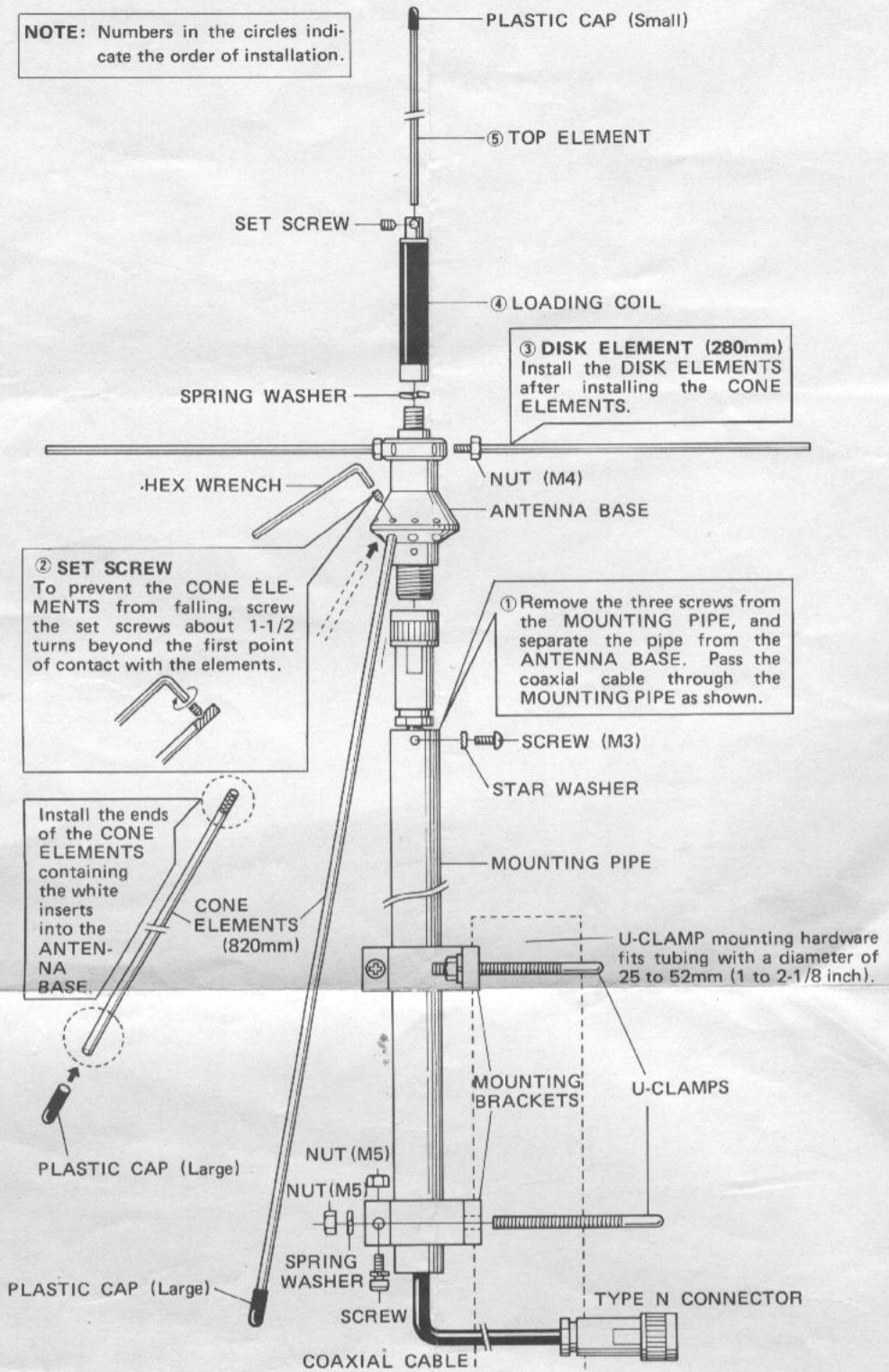

SPECIFICATIONS

Frequency coverage	Receive : 25 to 1300MHz
	Transmit : 50, 144, 430, 900, 1200MHz bands
Input power rating	: 200 watts
Input impedance	: 50 ohms
Supplied connectors	: Type N
Supplied coaxial cable	: 5D-2V (50 ohm)
Type of antenna	: Discone
Length	: 1.7 meters
Weight	: 1kg