

## ■ Panel description

The optional HM-127 remotely controls the IC-M502 and provides an optional intercom function.

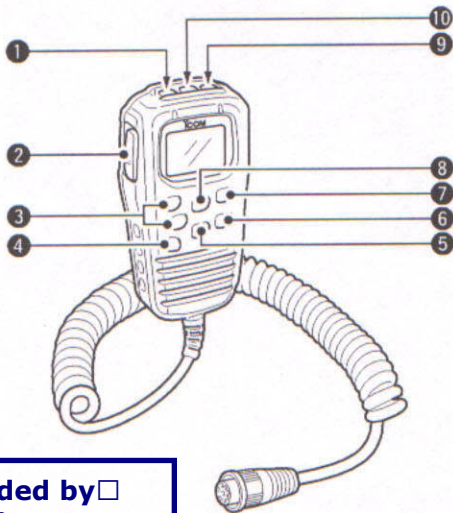

Downloaded by



Amateur Radio Directory

### ① POWER SWITCH [PWR] (pgs. 8, 51)

Push for 2 sec. to turn the HM-127 power ON or OFF when the IC-M502 power is turned ON.

### ② PTT SWITCH [PTT] (pgs. 8, 51)

Push and hold to transmit; release to receive.

### ③ CHANNEL UP/DOWN SWITCHES [▲]/[▼]

- Push either switch to change the operating channel, set mode contents, etc. (pgs. 8, 51)
- While pushing [H/L], push [▲]/[▼] to adjust the brightness of the LCD and switch backlight. (p. 52)
- Push either switch to adjust audio level or noise squelch level after [VOL] or [SQL] is pushed, respectively. (pgs. 8, 51)
- In set mode, changes setting of the selected item. (pgs. 9, 55)
- Checks tag channels or changes scanning direction during scan. (pgs. 8, 54)

### ④ CHANNEL 16/CALL CHANNEL SWITCH [16•9]

- Selects channel 16 when pushed. (pgs. 6, 50)
- Selects call channel when pushed for 1 sec. (pgs. 6, 50)
  - "CALL" appears when call channel is selected.
- Push for 3 sec. to enter call channel programming condition when call channel is selected. (pgs. 9, 53)
- While pushing [H/L], enters memory name programming condition. (pgs. 9, 56)
- Enters set mode when pushed while turning power ON. (pgs. 30, 55)

### ⑤ CHANNEL/DUALWATCH/TRI-WATCH SWITCH [CH/WX•DW•U//C]

- Selects and toggles the regular channels and weather channel when pushed momentarily. (pgs. 6, 7, 50)

- ➔ While pushing [H/L], selects one of 3 regular channels in sequence when pushed. (pgs. 6, 7, 50)
  - International, U.S.A. and Canadian channels are available for regular channels.

- ➔ Starts dualwatch or tri-watch when pushed for 1 sec. (pgs. 11, 54)
- ➔ Stops dualwatch or tri-watch when either is activated.

#### 6 ATTENUATOR/INTERCOM/SCRAMBLER SWITCH [LO/DX•IC•SCR]

- ➔ Toggles the attenuator function ON and OFF when pushed momentarily. (pgs. 8, 51)
  - "LOCAL" appears when the attenuator is in use.
- ➔ Activates the intercom function when pushed for 1 sec. (pgs. 29, 56)
- ➔ Calls the IC-M502 when pushed and held while in intercom mode. (pgs. 29, 56)
- ➔ While pushing [H/L], activates an optional voice scrambler function. (pgs. 10, 53)
  - The optional voice scrambler function cannot be used on channel 16 and 70.

#### 7 SQUELCH/MONITOR/LOCK SWITCH [SQL•MONI•L]

- ➔ [▲]/[▼] sets the squelch threshold level after pushing [SQL]. (p. 51)
- ➔ Push [SQL•MONI] for 1 sec. to turn the monitor function ON. (p. 52)
- ➔ While pushing [H/L], push [SQL•MONI•L] to toggle the microphone key lock function ON or OFF. (p. 52)
  - "🔒" appears while key lock function is in use.

- [PWR], [PTT], [VOL], [SQL] and [H/L] still function when the microphone key lock function is turned ON.

- ➔ Advance the cursor while in memory name programming condition. (pgs. 9, 56)

#### 8 VOLUME/DIMMER SWITCH [VOL•DIM]

- ➔ [▲]/[▼] adjusts the audio level after pushing [VOL].
- ➔ Push [VOL•DIM] for 1 sec. to adjust the brightness of the LCD and switch backlight. (p. 52)
- ➔ Move the cursor backward while in memory name programming condition. (pgs. 9, 56)

#### 9 TRANSMIT POWER SWITCH [H/L]

- ➔ Toggles high and low power when pushed. (pgs. 8, 51)
  - Some channels are set to low power only.
- ➔ While pushing this switch, other switches perform secondary functions.
- ➔ Toggles the all key lock function ON or OFF when pushed while turning power ON. (p. 52)
  - "🔒" flashes while the all key lock function is in use.
  - Only [PWR] and [PTT] function when the all key lock function is in use.

#### 10 SCAN SWITCH [SCN•TAG] (pgs. 13, 54)

- ➔ Starts and stops normal or priority scan when tag channels are programmed.
- ➔ Push [SCN•TAG] for 1 sec. to set the displayed channel as a tag (scanned) channel.
- ➔ While pushing [H/L], push for 3 sec. to clear all tag channels.

## ■ Function display

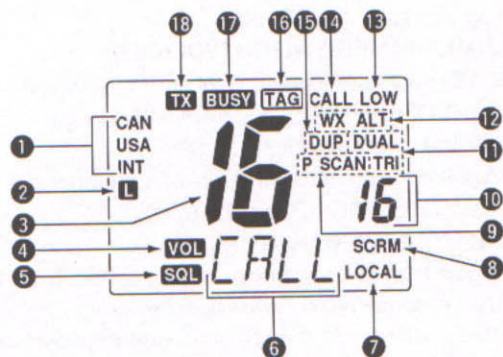

- 1 **CHANNEL GROUP INDICATOR** (pgs. 6, 50)  
Indicates whether an International (INT), U.S.A. (USA) or Canadian (CAN) channel is selected.
- 2 **KEY LOCK INDICATOR** (p. 52)  
  - Appears while the key lock function is in use.
  - Flashes while the all key lock function is in use.
- 3 **CHANNEL NUMBER READOUT**  
  - Indicates the selected operating channel number. "A" appears when a simplex channel is selected. (pgs. 6, 50)

➤ In set mode, indicates the selected condition. (pgs. 30, 55)

- 4 **VOLUME INDICATOR** (p. 51)  
Appears while audio output level is adjusted.
- 5 **SQUELCH INDICATOR** (p. 51)  
Appears while noise squelch level is adjusted.
- 6 **CHANNEL NAME INDICATOR**  
  - Channel comment appears (and scrolls) if programmed. (pgs. 9, 56)
  - In set mode, indicates or scrolls the selected set mode item. (pgs. 30, 55)
- 7 **ATTENUATOR INDICATOR** (pgs. 8, 51)  
Appears when the RF attenuator is in use.
- 8 **SCRAMBLER INDICATOR** (pgs. 10, 53)  
Appears when an optional voice scrambler is activated.
- 9 **SCAN INDICATOR** (pgs. 13, 54)  
  - "SCAN" appears during normal scan.
  - "P SCAN" appears during priority scan.
- 10 **PRIORITY CHANNEL INDICATOR**  
  - Indicates a priority channel during priority scan or dual/tri-watch. (pgs. 12, 54)
  - "IC" appears during intercom mode. (pgs. 29, 56)

- ① **DUAL/TRI WATCH INDICATOR** (pgs. 11, 54)  
"DUAL" appears during dualwatch; "TRI" during tri-watch.
- ② **WEATHER CHANNEL INDICATOR** (pgs. 7, 50)
  - "WX" appears when a weather channel is selected.
  - "ALT" appears when the weather alert function is in use; flashes when an alert tone is received.
- ③ **LOW POWER INDICATOR** (pgs. 8, 51)  
Appears when low power is selected.
- ④ **CALL CHANNEL INDICATOR** (pgs. 6, 50)  
Appears when the call channel is selected.
- ⑤ **DUPLEX INDICATOR** (pgs. 6, 50)  
Appears when a duplex channel is selected.
- ⑥ **TAG CHANNEL INDICATOR** (pgs. 13, 54)  
Appears when a tag channel is selected.
- ⑦ **BUSY INDICATOR** (pgs. 8, 51, 52)  
Appears when receiving a signal or when the squelch opens.
- ⑧ **TRANSMIT INDICATOR** (pgs. 8, 51)  
Appears while transmitting.

## ■ HM-127 supplied accessories

Accessories included with the HM-127:	Qty.
① Connection cable (OPC-1000: 6 m; 20 ft) .....	1
② Mounting base .....	1
③ Microphone hanger .....	1
④ Screws (M3 × 16; tapping) .....	5

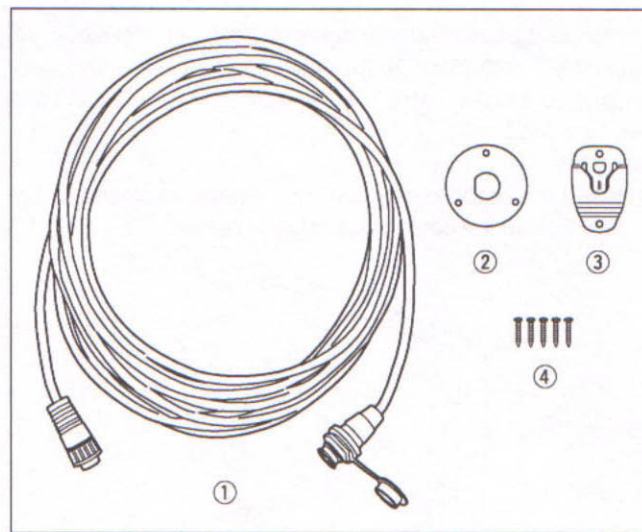

## ■ Installation

The optional HM-127 can be connected to the transceiver directly, as well as via the supplied connection cable for longer distance remote operation. The connector of the connection cable can be installed into a cabinet, wall, etc., as a built-in plug.

For longer distance remote operation, the optional extension cable, OPC-999 (6 m; 20 ft/Connecting between transceiver and the connection cable.), is available, and up to 2 OPC-999 can be added.

- ① Insert the supplied cable into the external microphone jack and tighten the cable nut as shown below.

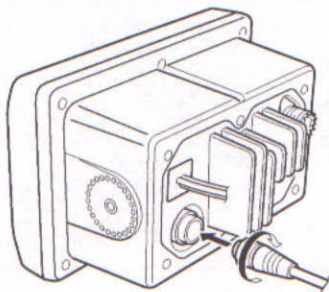

- ② To use the supplied cable as a wall socket, follow the following steps.
- ③ Using the mounting base, carefully mark off the 2 spots where the cable and screws will be fastened.
- ④ Drill holes at these marks.
- ⑤ Install the mounting base using screws as shown below.

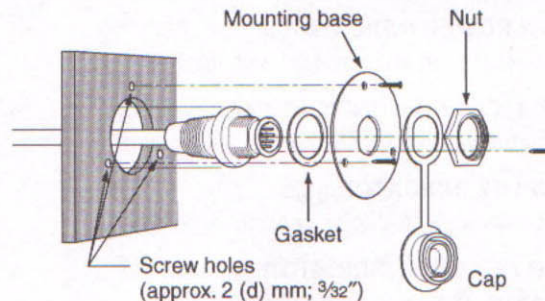

- ⑥ The installation is finished when it is completed.

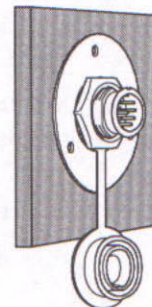

Downloaded by   
  
Amateur Radio Directory

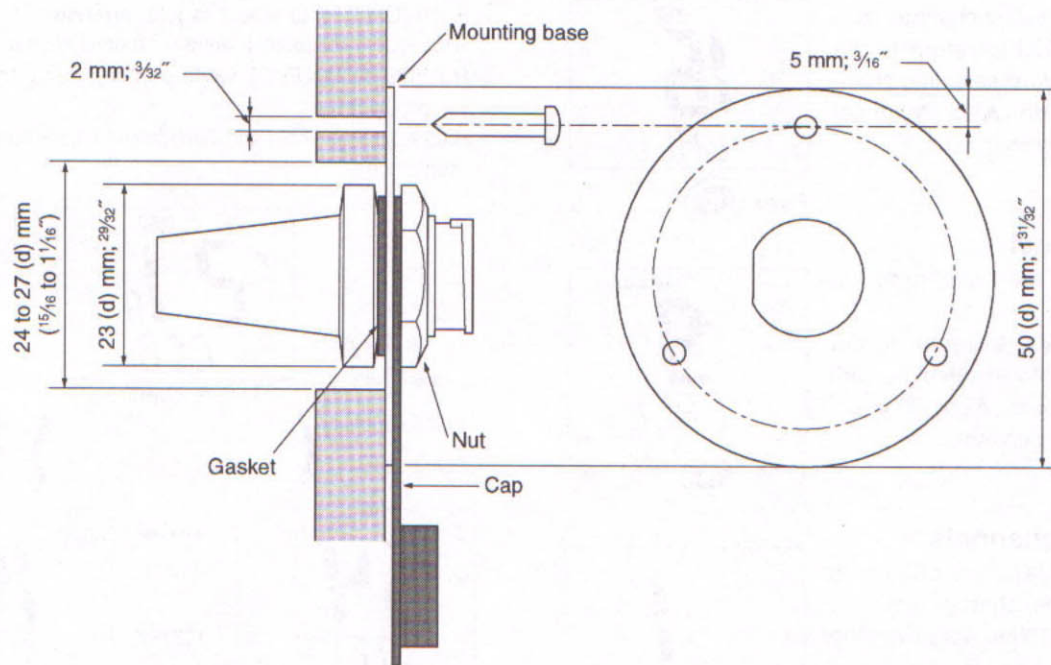

## ■ Channel selection

### ◆ Channel 16

- ① Push [16] to select channel 16.
- ② Push [CH/WX] to return to the condition before selecting channel 16, or push [▲] or [▼] to select operating channel.



Push 16

### ◆ Call channel

- ① Push [16•9] for 1 sec. to select call channel.
- ② Push [CH/WX] to return to the condition before selecting call channel, or push [▲] or [▼] to select operating channel.



Push 9 for 1 sec.

### ◆ Weather channels

- ① Push [CH/WX] once or twice to select weather channel group.
- ② Push [▲] or [▼] to select weather channel.
- ③ Push [CH/WX] to return to the condition before selecting the weather channel group.



Push CH/WX

### ◆ U.S.A., International and Canadian channels

- ① Push [CH/WX] to select regular channel.
  - Push [CH/WX] again, if weather channel appears.
- ② Push [CH/WX•U/I/C], while pushing [H/L], to select channel group.
  - U.S.A., International and Canadian channels can be selected in sequence.

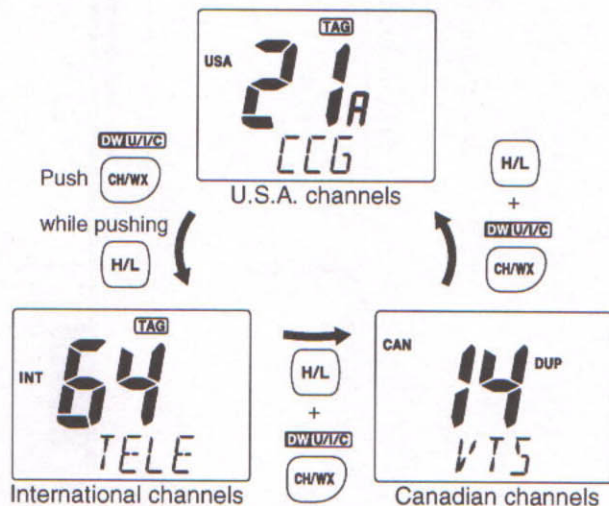

## ■ Receiving and transmitting

- ① Push [PWR] to turn power ON.
- ② Push [VOL], then [▲]/[▼] to adjust audio output level.
  - Push [SQL], then [▲]/[▼] to mute any audio noise, if necessary.
- ③ Push [▲]/[▼] to select the desired channel.
  - When receiving a signal, "BUSY" appears and audio is emitted from the speaker.
  - Further adjustment of audio level may be necessary at this point.
  - Use the optional voice scrambler function for privacy. (pgs. 10, 53)
- ④ Push [H/L] to select the output power, if necessary.
  - "LOW" appears when low power is selected.
  - Choose low power for shorter, high power for longer distance communications.
  - Some channels are low power only.

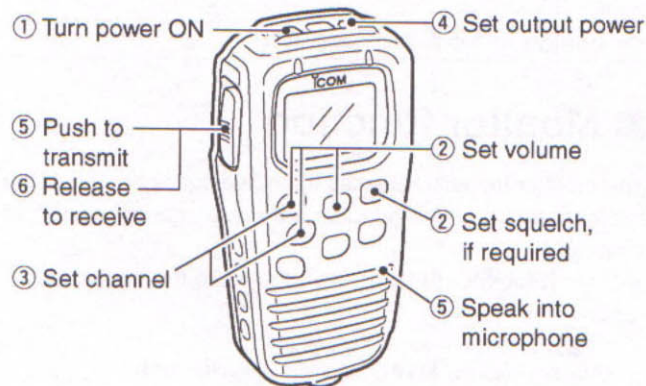

- ⑤ Push and hold [PTT] to transmit, then speak into the microphone.
  - "TX" appears.
  - Channel 70 cannot be used for transmission (for GMDSS use).

Simplex channels, 3, 21, 23, 61, 64, 81, 82 and 83 **CANNOT** be lawfully used by the general public in U.S.A. waters.

- ⑥ Release [PTT] to receive.

**IMPORTANT:** To maximize the readability of your transmitted signal (voice), pause a few sec. after pushing [PTT], hold the microphone 10 to 15 cm (4 to 6 inches) from your mouth and speak at a normal voice level.

## ■ RF attenuator function

- Push [LO/DX] to turn the RF attenuator function ON and OFF.



Appears when the RF attenuator function is in use



## ■ Lock functions

The lock function electronically locks keys and switches to prevent accidental changes and function access from the microphone.

• All keys, switches and controllers on the transceiver are functional.

### ◆ Activating the lock function

➔ Push [SQL] while pushing [H/L] to turn the lock function ON and OFF.

• "L" appears.

• Only [PWR], [PTT], [H/L], [SQL•MONI], [VOL]+[▲]/[▼] and [SQL]+[▲]/[▼] are functional.



Appears when the lock function is in use.

### ◆ Activating the all key lock function

➔ Turn the power ON by pushing [PWR] while pushing [H/L] to turn the all key lock function ON and OFF.

• "L" flashes.

• Only [PWR] and [PTT] are functional.



Flashes when the all lock function is in use.

## ■ Display backlighting

The function display and switches can be backlit for better visibility under low light conditions. And the backlighting condition can be adjusted independently from the transceiver.

① Push [VOL•DIM] for 1 sec. to enter backlight adjusting mode.

• "DIM" with number of backlight level appears in the channel name indicator.

② Push [▲]/[▼] to adjust the backlight level.

• The backlight level is adjustable between 0 (lights OFF) and 7 (brightest).

### *For your reference:*

Pushing [▲]/[▼], while [H/L] is pushed, also adjusts backlight level.

• No backlight level indication is available.

## ■ Monitor function

The monitor function releases the noise squelch mute of the microphone only. (An independent noise squelch system is employed.)

➔ Push [SQL•MONI] for 1 sec. to activate the monitor function.

• "BUSY" flashes and audio is emitted.

• Any key, except [▲]/[▼], cancels the monitor function.

## ■ Call channel programming

- ① Push [CH/WX•U/I/C] several times while pushing [H/L] to select the desired channel group (USA, INT, CAN) to be programmed.



- ② Push [16•9] for 1 sec. to select the call channel of the selected channel group.



- "CALL" and call channel number appear.

- ③ Push [16•9] again for 3 sec. (until long beep changes to 2 short beeps) to enter call channel programming condition.



- Call channel number and channel group to be programmed flashes.

- ④ Push [▲]/[▼] to select the desired channel.



- ⑤ Push [16•9] to program the displayed channel as the call channel.
- The call channel number and channel group stop flashing.



## ■ Optional voice scrambler operation

### ◇ Activating the scrambler

- ① Select an operating channel, except channel 16 or weather channels.
- ② Push [LO/DX•IC•SCR] while pushing [H/L] to turn the voice scrambler function ON.
  - "SCRM" appears.
- ③ To turn the scrambler function OFF, repeat step ②.
  - "SCRM" disappears.



Appears when the voice scrambler function is in use.

### ◇ Programming scramble codes

There are 128 codes (00 to 127) available with UT-98 or 32 codes (01 to 32) available with the UT-112 for programming. In order to understand one another, all transceivers in your group must have the same scrambler code, as well as the same scrambler unit. The scrambler code is programmed in set mode. See pgs. 10, 33, 55 for details.

Downloaded by   
  
 Amateur Radio Directory

## ■ Starting a scan

- ① Push [CH/WX•U/I/C] several times while pushing [H/L] to select the channel group (USA, INT, CAN), if desired.
  - When the weather alert function is in use, select the desired weather channel with [CH/WX] and [▲]/[▼].
- ② Push [SCN] to start priority or normal scan.
  - "SCAN" appears during normal scan.
  - The priority channel readout indicates "16", and "P" and "SCAN" indicators appear during priority scan.
  - When a signal is received, scan pauses until the signal disappears or resumes after pausing 5 sec. according to set mode setting (Channel 16 is still monitored during priority scan).
  - Push [▲]/[▼] to check the scanning tag channels, to change the scanning direction or resume the scan manually.
- ③ To stop the scan, push [SCN].
  - "SCAN" disappears.
  - Pushing [PTT], [16•9] or [CH/WX] also stops the scan.

## ■ Setting tag channels

- ① Push [CH/WX•U/I/C] several times while pushing [H/L] to select the channel group (USA, INT, CAN), if desired.
  - ② Push [▲]/[▼] to select the desired channel to set as a tag channel.
  - ③ Push [SCN•TAG] for 1 sec. to set the displayed channel as a tag channel.
    - "TAG" appears.
  - ④ To cancel the tag channel setting, push [SCN•TAG] for 1 sec.
    - "TAG" disappears.
- Clearing all tag channels in the selected channel group**
- ➡ Push [SCN•TAG] while pushing [H/L] for 3 sec. (until long beep changes to 2 short beeps).

## ■ Dualwatch/Tri-watch operation

- ① Push [▲]/[▼] to select the desired channel.
  - Push [CH/WX•U/I/C] several times while pushing [H/L] to select the channel group (USA, INT, CAN), if desired.
- ② Push [CH/WX•DW] for 1 sec. to start dualwatch or tri-watch.
  - "DUAL" appears during dualwatch; "TRI" appears during tri-watch.
  - Beep tone sounds when a signal is received on channel 16.
  - Tri-watch becomes dualwatch when receiving a signal on the call channel.
- ③ To cancel dualwatch/tri-watch, push [CH/WX•DW] again.

## ■ Set mode programming

Set mode is used to change the condition of the transceiver's functions and the microphone's own functions:

Transceiver's functions—

scan mode (normal or priority), scan resume timer, weather alert, dualwatch/tri-watch selection, DSC watch, transceiver's beep tone, internal speaker (transceiver), LCD contrast (transceiver), RF attenuation level, scrambler code and scrambler type.

Microphone's own functions—

beep tone function (microphone) and LCD contrast (microphone).

In this section, instructions are for the microphone's own functions only. Refer pgs. 30–33 for the setting of the other functions. (Some functions may not be selected from the microphone.)

### ◆ Entering set mode

- ① Turn power OFF.
- ② While pushing [16•9], turn power ON.
  - After beep emission, a set mode item (in the channel name indicator and condition in the channel number readout) is displayed.
- ③ Push [16•9] to select the desired item, if necessary.
- ④ Push [▲]/[▼] to select the desired condition of the item.
- ⑤ Turn power OFF, then ON to exit set mode.

#### • Beep tone "BEEP"

➡ Push [▲] to turn ON, [▼] to turn OFF the beep output.

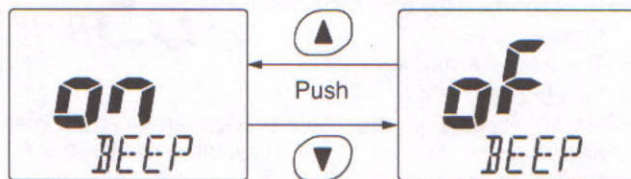

#### • LCD contrast "LCD CONTRAST"

➡ Push [▲]/[▼] to adjust to a suitable LCD contrast.

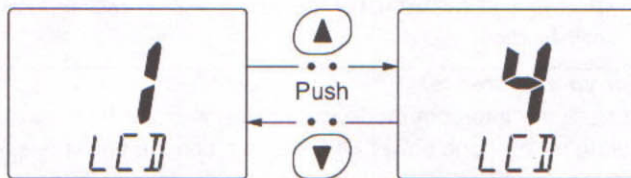

## ■ Intercom operation

- ① Push [LO/DX•IC] for 1 sec. to activate the intercom function.
  - "IC" appears in the priority channel readout.
  - The channel name disappears.
- ② Push [PTT] to talk.
  - "TALK" appears in the channel name indicator.
- ③ Release [PTT] to listen.
  - "LSTN" appears in the channel name indicator when the transceiver is in talking.
- ④ Push [LO/DX•IC] to cancel the intercom function.
  - Pushing [16], [SCN•TAG] or [CH/WX] is also cancels the intercom function.



Appears when the intercom function is in use.

### For your reference:

In case the intercom mode is selected with the transceiver during microphone power OFF, the microphone power is automatically turned ON and the intercom mode is selected.

### ◆ Intercom beep function

- ➡ Push [LO/DX•IC] for more than 1 sec.
  - Emits intercom beep while holding.

## ■ Channel names

- ① Push [▲]/[▼] to select a channel to program.
  - Push [CH/WX•U/I/C] several times while pushing [H/L] to select the channel group (USA, INT, CAN), if desired.
- ② While pushing [H/L], push [16•9].
  - The 1st character of the currently programmed comment flashes.
- ③ Push [▲]/[▼] to select a character.
- ④ Push [SQL] to move to right; then push [▲]/[▼] to select a character.
  - Push [VOL] to move to the left.
- ⑤ Continue until the desired characters have been selected, the push [16•9] to return to normal operation.

### • Available characters

(space)	! (!)	" (")	# (#)	\$ (\$)	% (%)	& (&)	' (')	( ( (	) ( )
* (*)	+ (+)	, (,)	-- (-)	. (.)	/ (/)	0 (0)	1 (1)	2 (2)	3 (3)
4 (4)	5 (5)	6 (6)	7 (7)	8 (8)	9 (9)	A (A)	B (B)	C (C)	D (D)
E (E)	F (F)	G (G)	H (H)	I (I)	J (J)	K (K)	L (L)	M (M)	N (N)
O (O)	P (P)	Q (Q)	R (R)	S (S)	T (T)	U (U)	V (V)	W (W)	X (X)
Y (Y)	Z (Z)	a (a)	b (b)	c (c)	d (d)	e (e)	f (f)	g (g)	h (h)
i (i)	j (j)	k (k)	l (l)	m (m)	n (n)	o (o)	p (p)	q (q)	r (r)
s (s)	t (t)	u (u)	v (v)	w (w)	x (x)	y (y)	z (z)		

# TEMPLATE

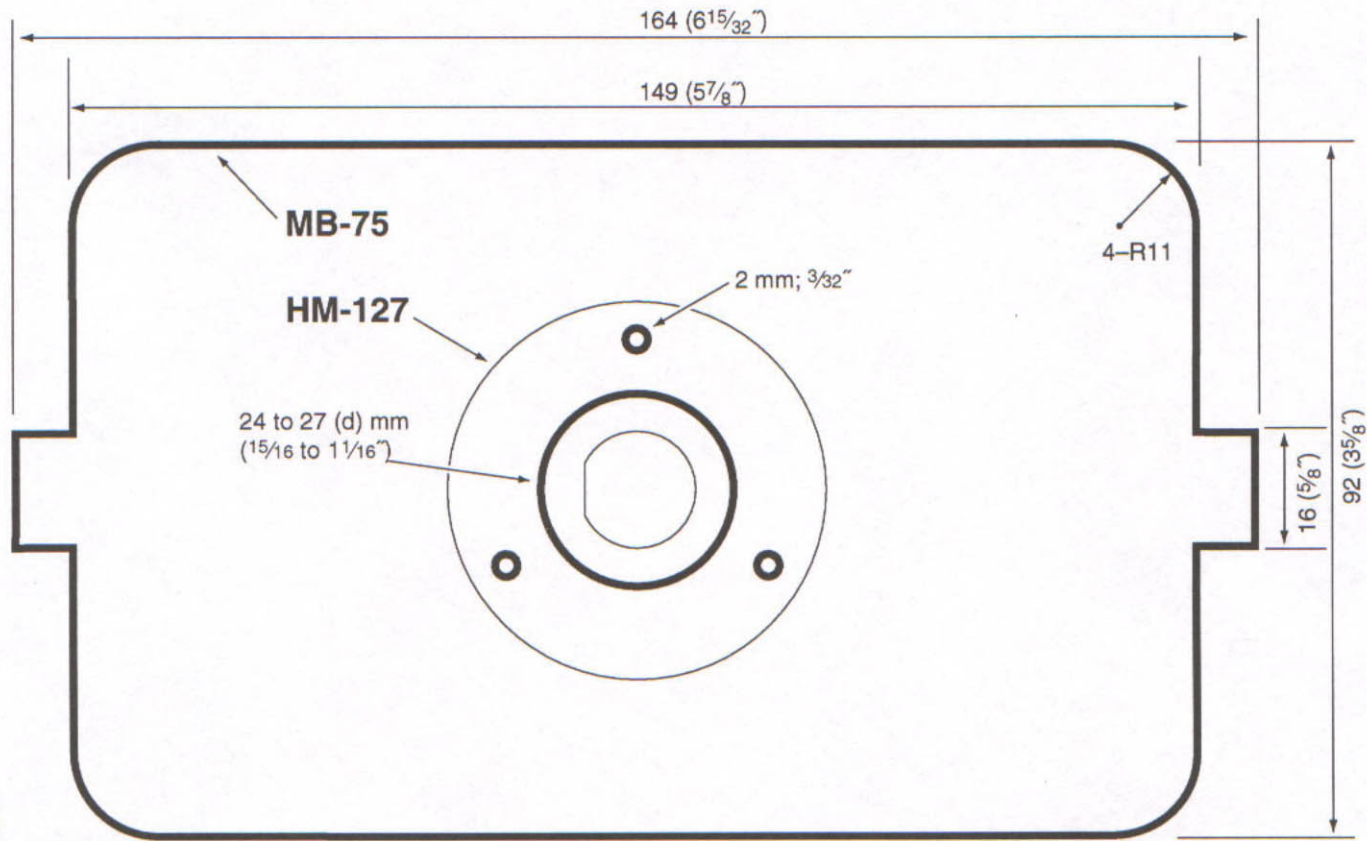

Cut here

Unit: mm (inch)

**Count on us!**

A-5663H-1EX  
Printed in Japan  
© 2000 Icom Inc.

**Downloaded by**   
  
**Amateur Radio Directory**

**Icom Inc.**  
6-9-16 Kamihigashi, Hirano-ku, Osaka 547-0002 Japan