



I/Q OUTPUT REFERENCE GUIDE

HF/50 MHz TRANSCEIVER

IC-7760

TABLE OF CONTENTS

I/Q SIGNAL	2
General.....	2
◇ General description	2
Communication through the [USB] port (for I/Q output).....	3
◇ General description	3
◇ About the Device Description	3
◇ About the endpoints	3
About the I/Q signals	4
◇ General description	4
◇ I/Q data format	4
Control commands	5
◇ General description	5
◇ Command format.....	5
◇ Command table.....	7
Control commands relative to the I/Q port settings	8
◇ Antenna.....	8
◇ Operating frequency.....	8
◇ Operating mode.....	9
◇ Setting after directly specifying the Main/Sub band	10

I/Q SIGNAL

General

◇ General description

You can get I/Q signals from the [USB] port on the RF deck's rear panel by connecting the IC-7760 and a PC with a USB cable. You can receive I/Q signals and control the IC-7760, through the USB cable.

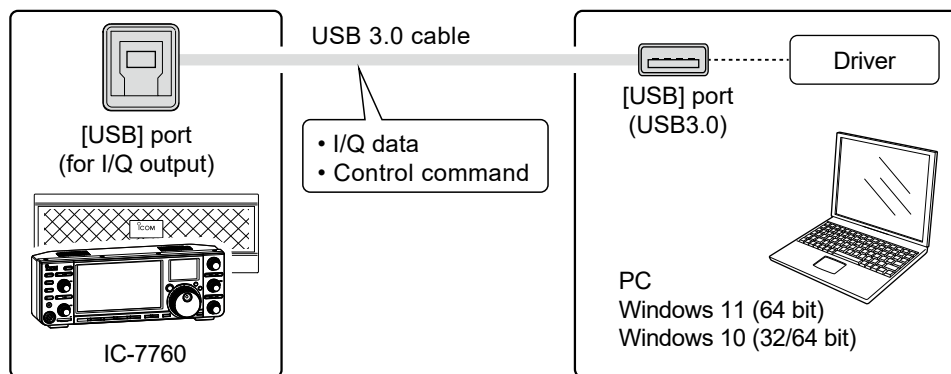

Requirements:

- IC-7760
- Windows 11 (64 bit) or Windows 10 (32 bit/64 bit) PC
- USB 3.0 or higher
- USB I/Q driver (USB I/Q Package for HSDR)

You can download it from the Icom website. (The software is commonly used with HSDR*.)

*An SDR receive software (freeware). You can download it from: <https://www.hdsdr.de/>

I/Q signal specifications:

Sampling frequency	Bit depth	Signal Bandwidth	Band (Main/Sub)
1.92 MHz	16-bit	1.66 MHz	Main or Sub (Selectable)

Communication through the [USB] port (for I/Q output)

◇ General description

I/Q signals and IC-7760 control commands are exchanged through the [USB] port on the RF deck's rear panel.

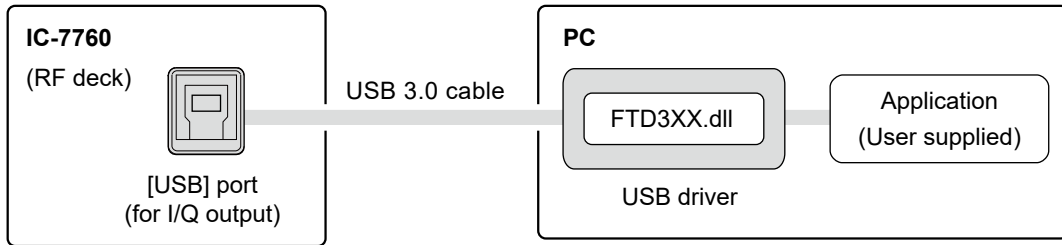

The communications are done through FTDI's "D3XX Driver."
 You need to install the driver (USB I/Q Package for HDSDR) that can be downloaded from Icom website.
 After the driver is installed, you can receive I/Q signals and control the IC-7760 through the D3XX Driver, using an I/Q receive software (user supplied).
 To receive I/Q signals and control the IC-7760 from the user application, you need FTDI's "FTD3XX.dll." Refer to "D3XX Programmer's Guide" that can be downloaded from the FTDI website on how to use the functions.

You need to set the device description and appropriate "endpoints." Refer to the next topic for details about them.

◇ About the Device Description

The Device Description, that is needed to open the [USB] port (for I/Q output), is shown below.
"IC-7760 SuperSpeed-FIFO Bridge"

◇ About the endpoints

The IC-7760 has 3 endpoints. Each endpoint is reserved to receive I/Q data, to send control commands to the IC-7760 and to receive the acknowledgement from the IC-7760.

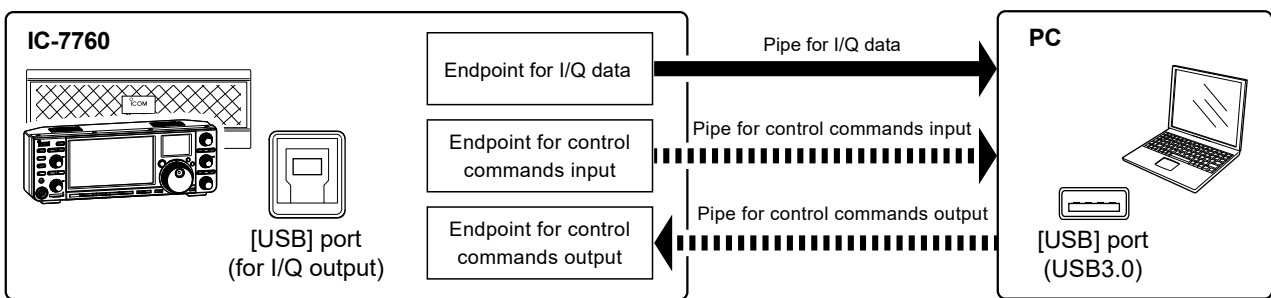

Details of each endpoint:

	Address (Hexadecimal)	Direction*	Endpoint Number (Hexadecimal)	Transfer Type
I/Q Data IC-7760 → PC	84	IN	04	Bulk transfer
Control command IC-7760 → PC	82	IN	02	Bulk transfer
Control Command PC → IC-7760	02	OUT	02	Bulk transfer

*IN: Data from IC-7760 to PC, OUT: Data from PC to IC-7760

About the I/Q signals

◇ General description

I/Q data is output from the [USB] port on the RF deck's rear panel. One endpoint is reserved to receive I/Q signals.

	Address (Hexadecimal)	Direction	Endpoint Number (Hexadecimal)	Transfer Type
I/Q Data IC-7760 → PC	84	IN	04	Bulk transfer

The sampling frequency, Bit depth and I/Q signal bandwidth are fixed as follows.

Sampling frequency	Bit depth	Signal Bandwidth	Band (Main/Sub)
1.92 MHz	16-bit	1.66 MHz	Main or Sub (Selectable)

TIP: The sampling frequency can be set to 960 kHz or less in the HSDR application. You can select the Bit depth in the HSDR application. These are achieved by processing down sampling and bit conversion on the PC.

◇ I/Q data format

Data format:

The I/Q data is composed of 2 parts: "I" signals and "Q" signals. Each data length is: "I" =16 bits (2 Bytes), "Q" =16 bits (2 Bytes). (The byte order is in the little-endian format.)

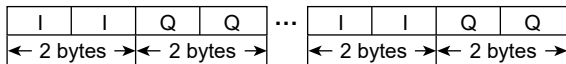

- The I/Q data range is “-32768 (0x8000) ~ +32767 (0x7FFF).”
- The I/Q data is formed in increments of 4 bytes. Therefore the most significant byte must be an I signal.

Control commands

◇ General description

The following 2 endpoints are reserved for sending control commands:

- Sends the control commands from a PC to the IC-7760.
- Sends the acknowledgement from the IC-7760 to the PC.

	Address (Hexadecimal)	Direction	Endpoint Number (Hexadecimal)	Transfer Type
Control command IC-7760 → PC	82	IN	02	Bulk transfer
Control Command PC → IC-7760	02	OUT	02	Bulk transfer

① The control command format is based on the ICOM Communication Interface V (CI-V) format.

② There are 2 command types: Writing commands and Reading commands. Refer to the next topic for details about them.

◇ Command format

You can control the IC-7760 using the CI-V commands. Every command is composed of a byte array in hexadecimal. Every command byte must be in increments of 4 bytes.

After sending a command from the PC to the IC-7760, an acknowledgement is returned. When you send commands one after another, you need to send the next command after the acknowledgement is received.

Writing command format:

Send a writing command from the PC to change an IC-7760 setting.

A writing command is composed of a command number and setting data that follows the command.

The IC-7760 will return the result as an acknowledgement after receiving the command.

• Command (PC to IC-7760)

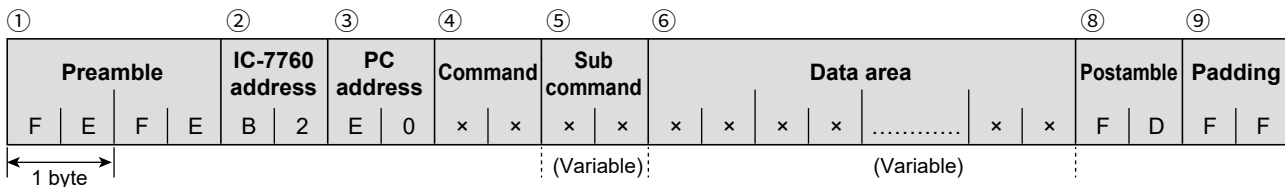

• Acknowledge of a valid command (IC-7760 to PC)

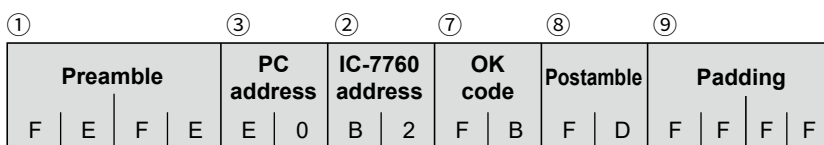

• Acknowledge of an invalid command (IC-7760 to PC)

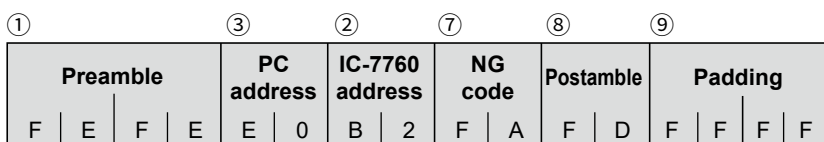

Control commands

◇ Command format

Reading command format:

Send a request command from the PC to request to return an IC-7760 setting value.

A reading command is composed of only a command number.

The IC-7760 will return the requested setting value as an acknowledgement when receiving the command.

If the request command is invalid, "NG (FA)" will be returned as the acknowledgement.

• **Command (PC to IC-7760)**

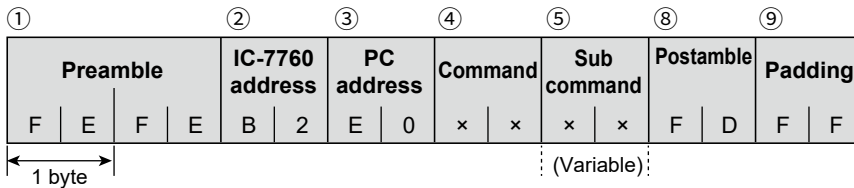

• **Acknowledgement of a valid command (IC-7760 to PC)**

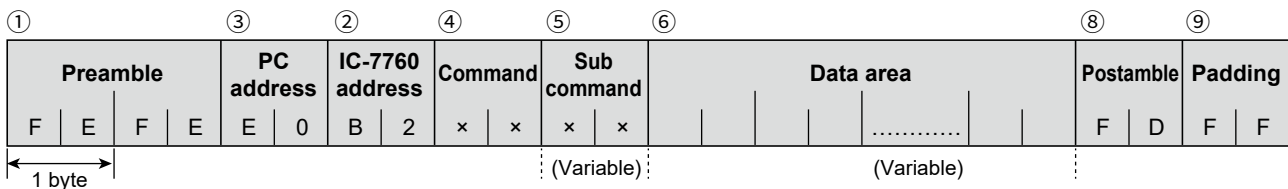

• **Acknowledgement of an invalid command (IC-7760 to PC)**

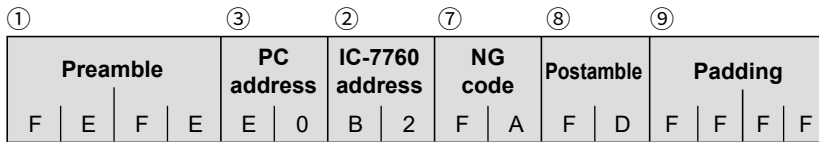

PC to IC-7760

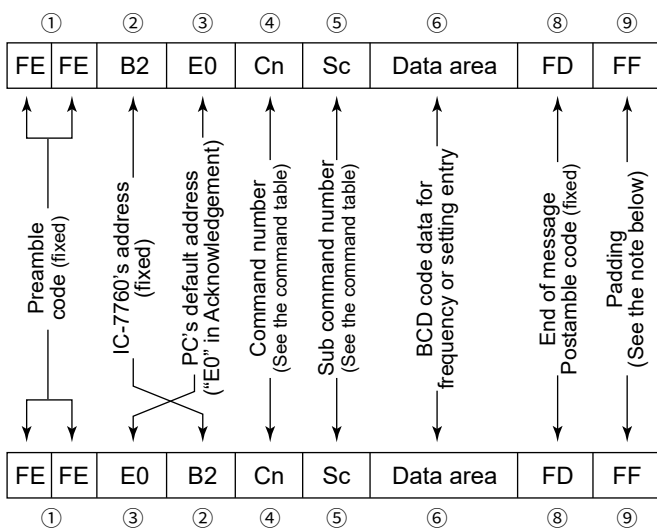

IC-7760 to PC

OK message to PC

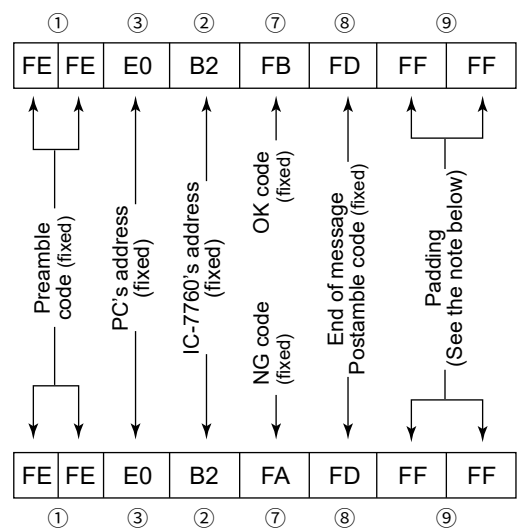

NG message to PC

NOTE: When the data length is not in increments of 4 bytes

Every command must be in increments of 4 bytes.

If the command is not in increments of 4 bytes, you need to add an extra "FF" at the end of the packet, to make the command length multiples of 4. In the same manner, the length of the acknowledgement data from the IC-7760 is multiples of 4.

Control commands

◇ Command table

Cmd.	Sub cmd.	Data	Description
07	C2	00/01	Send/read the dualwatch setting (00=OFF, 01=ON)
	D2	00	Send/read Main band selection
		01	Send/read Sub band selection
0F		00/01	Read Split setting (00=Split OFF, 01=Split ON)
11 ²⁹		00	Send/read attenuator OFF setting
		03	Send/read 3 dB attenuator setting
		06	Send/read 6 dB attenuator setting
		09	Send/read 9 dB attenuator setting
		12	Send/read 12 dB attenuator setting
		15	Send/read 15 dB attenuator setting
		18	Send/read 18 dB attenuator setting
		21	Send/read 21 dB attenuator setting
		24	Send/read 24 dB attenuator setting
		27	Send/read 27 dB attenuator setting
		30	Send/read 30 dB attenuator setting
		33	Send/read 33 dB attenuator setting
		36	Send/read 36 dB attenuator setting
		39	Send/read 39 dB attenuator setting
		42	Send/read 42 dB attenuator setting
	45	Send/read 45 dB attenuator setting	
12 ²⁹ See p. 8.	00*1	00/01	Send/read ANT1 selection (00=RX ANT OFF, 01=RX ANT ON)
	01*1	00/01	Send/read ANT2 selection (00=RX ANT OFF, 01=RX ANT ON)
	02*1	00/01	Send/read ANT3 selection (00=RX ANT OFF, 01=RX ANT ON)
	03*1	00/01	Send/read ANT4 selection (00=RX ANT OFF, 01=RX ANT ON)

Cmd.	Sub cmd.	Data	Description
14	02 ²⁹	00 00 ~ 02 55	Send/read the RF gain level (00 00=Minimum ~ 02 55=Maximum)
16	02 ²⁹	00	Preamp OFF
		01	Preamp 1 ON
		02	Preamp 2 ON
	4E ²⁹	00/01	Send/read the DIGI-SEL function (00=OFF, 01=ON)
	65 ²⁹	00/01	Set the IP Plus function (00=OFF, 01=ON)
1A	0A*2 ²⁹	00/01	Read the OVF indicator status (00=OFF, 01=ON)
	0B*3	00 ~ 02	Send/read the I/Q data output setting (00=OFF, 01=Main band I/Q output, 02=Sub band I/Q output)
1C	00	00/01	Send/read the transceiver's status (00=RX, 01=TX)
	02	00/01	Send/read the Transmit frequency monitor (XFC) (00=OFF, 01=ON)
25		See p. 8.	Send/read the Main or Sub band frequency
26		See p. 9.	Send/read the operating mode and filter setting (for both Main and Sub bands)
29		00 or 01 + Supported commands See p. 10.	Regardless of active/inactive the Main or Sub band, you can directly specify the Main or Sub band, and send/read the supported command settings. (00=MAIN, 01=SUB)

²⁹ Command 29 supported.

*1 If the Antenna Type is set to "RX-I/O," command "01 (RX ANT ON)" is invalid and "00 (RX ANT OFF)" is always returned.

*2 1A 0A cannot be sent.

*3 Valid only when the RF deck's [USB] port (for I/Q output) is connected.

Control commands relative to the I/Q port settings

◇ Antenna

Command: 12

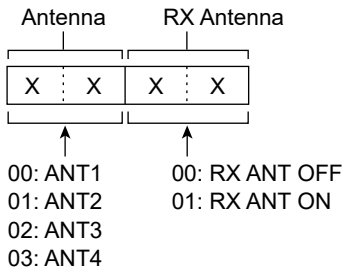

① If the Antenna Type is set to “RX-I/O,” command “01 (RX ANT ON)” is invalid and “00 (RX ANT OFF)” is always returned.

◇ Operating frequency

Command: 25

• **Reading**

Command (PC to IC-7760)

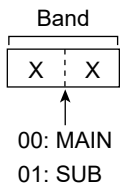

Acknowledgement of a valid command (IC-7760 to PC)

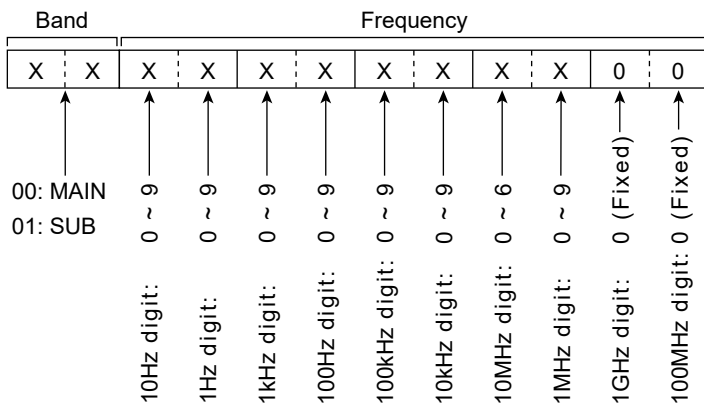

• **Setting**

Command (PC to IC-7760)

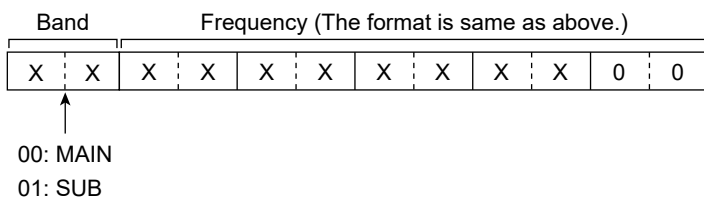

① Fill each digit with the BCD value.
 ② If you omit entry of the upper digits, the current frequency will be applied to the upper digits.

Control commands relative to the I/Q port settings

◇ **Operating mode**

Command: 26

• **Reading**

Command (PC to IC-7760)

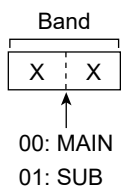

Acknowledgement of a valid command (IC-7760 to PC)

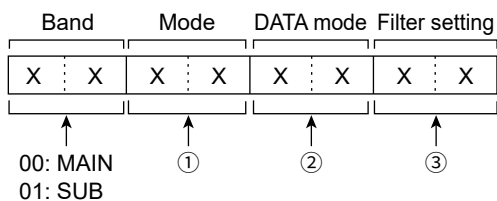

① Operating mode	② DATA mode	③ Filter setting	
00: LSB	05: FM	00: OFF	01: FIL1
01: USB	07: CW-R	01: D1	02: FIL2
02: AM	08: RTTY-R	02: D2	03: FIL3
03: CW	12: PSK	03: D3	—
04: RTTY	13: PSK-R	—	—

• **Setting**

Command (PC to IC-7760)

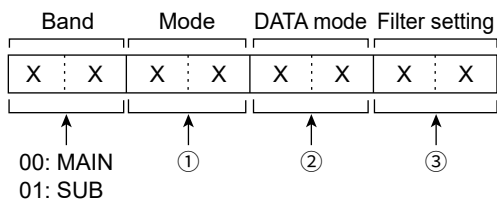

① The data format is the same as that of “Reading.”

② You can omit the DATA mode and Filter settings. When omitted, the current setting is applied.

Control commands relative to the I/Q port settings

◇ **Setting after directly specifying the Main/Sub band**

Command: 29

Specify the Main or Sub band before entering the supported commands.

When you receive the OK code (FB), or the NG code (FA), Command 29 and the Main/Sub specified 00 or 01 is omitted.

• **Reading**

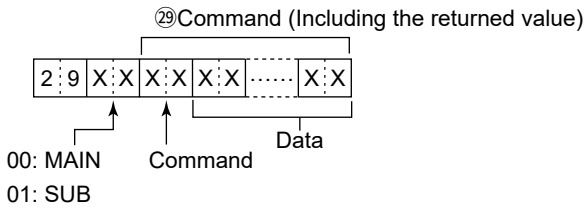

Example: Reading the Main band RF gain using the “14 02” command.

Command (PC to IC-7760)

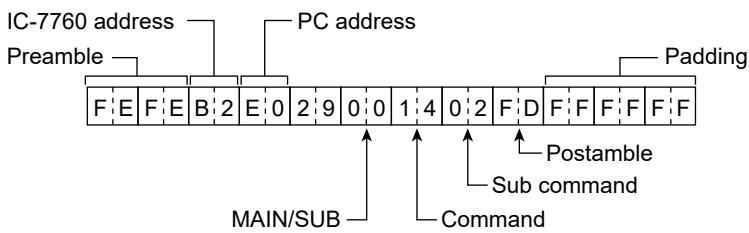

Acknowledgement of a valid command (IC-7760 to PC)

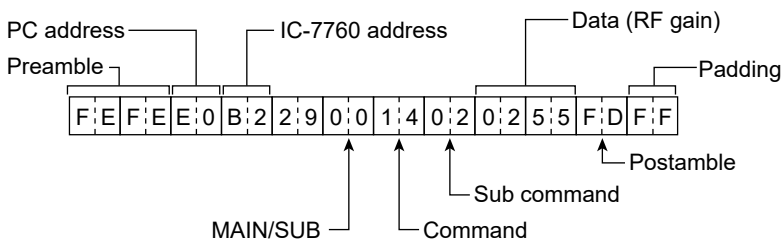

Control commands relative to the I/Q port settings

◇ Setting after directly specifying the Main/Sub band

Command: 29

Specify the Main or Sub band before entering the supported commands.

When you receive the OK code (FB), or the NG code (FA), Command 29 and the Main/Sub specified 00 or 01 is omitted.

• **Setting**

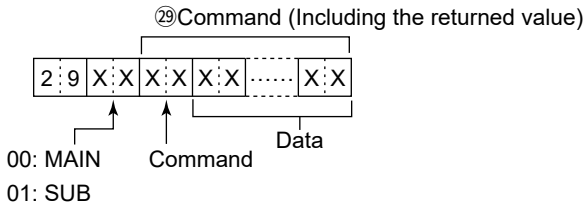

Example: Setting the SUB band RF gain to “128” using 14 02 command.

Command (PC to IC-7760)

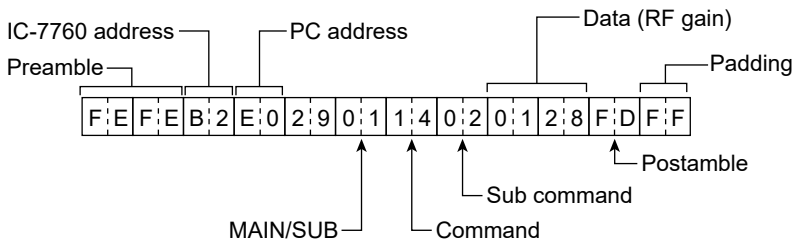

Acknowledgement of a valid command (IC-7760 to PC)

