

Version 1.0  
May 2008



# IC-FR5000/FR6000 Series Sales Handbook

**DIGITAL**

**iDAS**  
ICOM DIGITAL ADVANCED SYSTEM



**Icom Inc.**

## Foreword

This handbook is prepared to provide detailed information about the IC-FR5000/IC-FR6000 series VHF and UHF FM Repeaters.

## Disclaimer

The information in this document has been carefully checked, and is believed to be correct and accurate. However, Icom assumes no responsibility for inaccuracies or mistakes. Furthermore, Icom reserves the right to make changes to any of the products described in this handbook without notice or obligation. The systems and applications described herein are for information and reference purposes only.

### Handbook Revisions

Icom reserves the right to make changes to the content of this handbook at any time without notice or obligation.

### IPR and Copyrights

The Icom products described in this handbook may include Icom Intellectual Property Rights (IPR) and/or copyrighted Icom computer programs stored in radio memories or other media/devices. Such IPR and copyrighted computer programs are protected by laws in Japan, the United States and other countries. Any Icom IPR and/or copyrighted Icom computer programs contained in the Icom products described in this manual may not be copied, reproduced, modified, reverse-engineered, or distributed in any way. Furthermore, the purchase of Icom products shall not be deemed to grant any license either directly or by implication, except for the normal non-exclusive license to use the product that is specified by law in the sale of a product.

### Document Copyrights

No duplication or distribution of this document or any portion thereof shall take place without the express permission of Icom. Reproduction, distribution, or transmission for any purpose in any form or by any means, electronic or mechanical, shall only be allowed with the express permission of Icom.

### Trademarks

Icom, Icom Inc. and the Icom logo are registered trademarks of Icom Incorporated (Japan) in the United States, the United Kingdom, Germany, France, Spain, Russia and/or other countries.

Microsoft, Windows and Windows Vista are either registered trademarks or trademarks of Microsoft Corporation in the United States and/or other countries.

This product when used with certain options, utilizes vocoding technology that is the property of Digital Voice Systems Inc. The AMBE+2™ voice coding Technology embodied in this product is protected by intellectual property rights including patent rights, copyrights and trade secrets of Digital Voice Systems, Inc. This voice coding Technology is licensed solely for use within this Communications Equipment. The user of this Technology is explicitly prohibited from attempting to extract, remove, decompile, reverse engineer, or disassemble the Object Code, or in any other way convert the Object Code into a human-readable form. U.S. Patent Nos. #5,870,405, #5,826,222, #5,754,974, #5,701,390, #5,715,365, #5,649,050, #5,630,011, #5,581,656, #5,517,511, #5,491,772, #5,247,579, #5,226,084 and #5,195,166.

All other products or brands are registered trademarks or trademarks of their respective holders.

### Regarding Application Examples

All application examples shown in this handbook are for your reference only. Icom has not tested or carried out performance checks for many of these examples, so does not guarantee they will work if tried. We suggest you carry out testing before recommending to customers.

## Table of Contents

1	Introduction	
1-1	Company Profile .....	4
2	Overview	
2-1	Product Line Up .....	5
2-2	Common Features .....	6-7
2-3	6.25kHz FDMA Technology .....	8-12
2-4	Function and Specifications	
2-4-1	VHF FM Repeaters .....	13
2-4-2	UHF FM Repeaters .....	14
3	Accessories	
3-1	Optional Accessories .....	15
3-1-1	Installation and Connection .....	16-17
3-1-2	UR-FR5000/UR-FR6000 Installation .....	18-19
4	Operation and Function	
4-1	Panel Description .....	20-21
4-1-1	Functions Programmable to Assignable Keys .....	22-23
4-1-2	Display Assign .....	24
4-1-3	Connector Description .....	25-26
4-2	Cloning Software CS-FR5000	
4-2-1	Basic Setup of Cloning Software .....	27-28
4-2-2	Cloning Items .....	29
4-3	Operation .....	30
4-4	Multiple Table .....	31
4-5	Remote Control Function .....	32-33
4-6	Scan .....	34-35
4-7	Voice Scrambling /Encryption .....	36-37
5	Applications	
5-1	Digital-Analog Mixed System .....	38
5-1-1	Analog to Digital Migration Path .....	39
5-2	Digital-Analog Cross System .....	40-42
5-3	Repeater Linking System	
5-3-1	Repeater Linking System (1) .....	43
5-3-2	Repeater Linking System (2) .....	44
5-3-3	Repeater Linking System (3) .....	45
5-4	Phone Patch and Tone Remote .....	46
5-5	MPT1327 Trunking System .....	47-49
5-6	LTR™ Trunking System	
5-6-1	Single Site LTR™ Trunking System .....	50
5-6-2	Digital Networked LTR™ or PassPort™ Trunking System .....	51
5-6-3	Analog Networked LTR™ or PassPort™ Trunking System .....	52
5-7	Solar Powered Repeater System .....	53-54
5-8	Wind-Solar Hybrid Powered Repeater System .....	55-56
5-9	Wind and Solar Power Components .....	57
6	Maintenance .....	58
	Appendix	
A-1	Promotional Materials .....	59
A-2	Instruction Manual and Other Materials .....	60

## Company Profile

### **Icom, the wireless communication experts**

Icom Inc. is a company located in Osaka, Japan, and is a manufacturer of wireless communication products. Since Icom's establishment in 1954, we have had a long record as a trusted manufacturer of land mobile radio, amateur radio, marine radio, navigation products, aviation radio and communications receivers.

## Quality & Reliability

### **Icom quality and Icom reliability**

Over 50 years of engineering and production excellence is a part of every Icom product. Using the latest equipment, Icom radios are tested to pass rigorous in-house tests as well as environmental tests to the US Military standard 810 specifications. Icom Inc holds ISO9001:2000 certification.

## Production

### **Made in Japan quality**

Icom is a rare example of an electronics manufacturer that has not shifted production to lower cost countries, but kept its production base 100% in Japan. The Wakayama Icom plant has an advanced production system to produce small volume/multi-model wireless communication products.

## Icom brand

### **Icom, world brand name**

Icom is today recognized as a reliable 2-way radio brand name around the world. Our land mobile radios are used by many professional organizations all over the world, like the United States Department of Defense and the U.S. Marine Corps. who chose Icom as the first Japanese company to supply radios to them.

## Network

### **Icom's worldwide network**

Icom's products are sold in over 80 countries in the World. Icom has an international sales and service network around the world, including sales subsidiaries in the US, Australia, Germany, Spain and liaison offices in France and China. Icom is here to support and service our products and your communication needs.

*VHF FM Repeater*  
**IC-FR5000**  
*UHF FM Repeater*  
**IC-FR6000**



**Supplied Accessories**

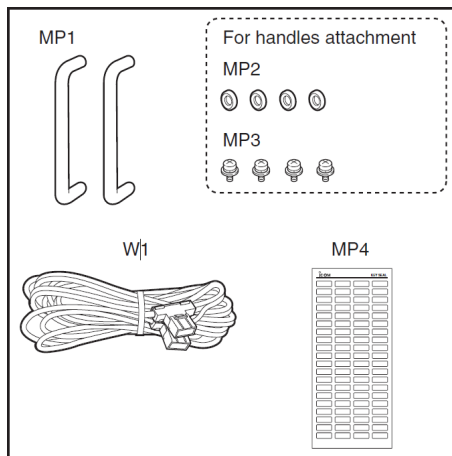

W1	DC Power Cable (OPC-1784) .....	1
MP1	3063 Handle .....	2
MP2	3063 H-Spacer .....	4
MP3	Setscrew (C) (4x12 ZK3) .....	4
MP4	3063 Key Seal .....	1

**Dimensions**

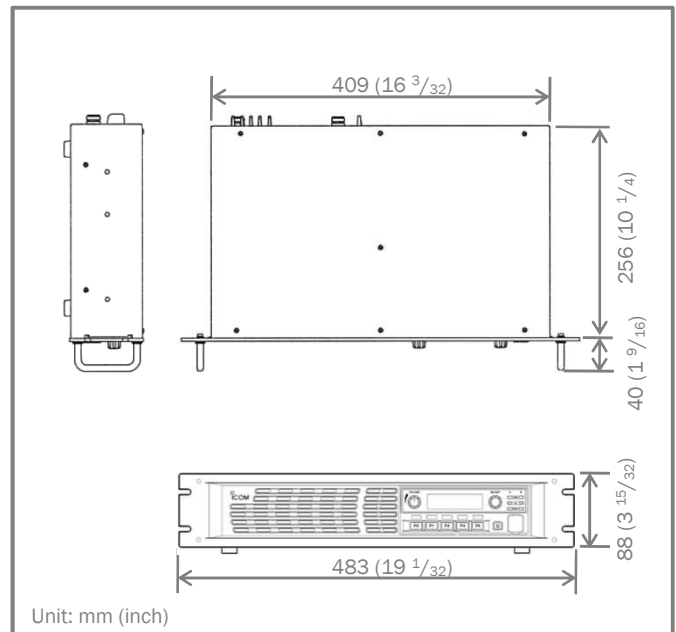

Unit: mm (inch)

## “IDAS” 6.25KHZ DIGITAL CAPABLE REPEATERS

The IC-FR5000/FR6000 series is the first Icom “IDAS” 6.25kHz digital capable repeater, in addition to the IC-F3160, F5060 series radios. The “IDAS” system increases existing 12.5kHz channel capacity and offers easy migration from analog to digital.

### IDAS DIGITAL FEATURES

#### Digital/analog mixed mode operation

The IDAS radio (including repeater) can receive both analog mode and digital mode signals on a single channel. You can partially introduce the IDAS digital radios, while using the existing analog radios in a system. The IDAS system allows you to scale migration to narrow band digital at your own pace and need, while running your existing analog system. A cost efficient way to obtain the next generation in two way radio technology.

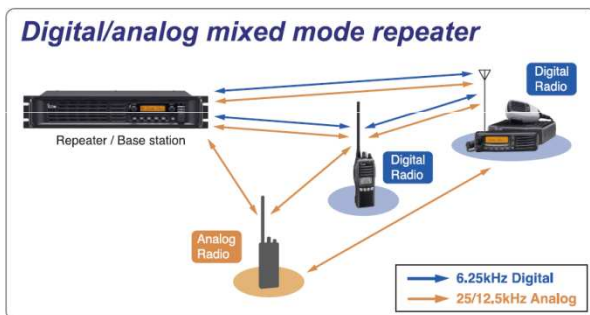

#### Double your channel capacity

The IDAS system utilizes 6.25kHz narrow channel spacing, which when in a 12.5kHz channel, you can create two offset 6.25kHz channels. (i.e. doubling the channel efficiency and capacity.) You can use these channels, for example, in a one for voice and one for data communication configuration.

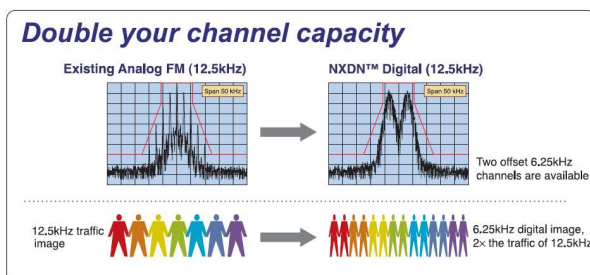

#### Data communication

The IDAS system allows you 4800 bps\* data communication. You can send a data message or GPS position data without an external data modem.

\*Error correction, control data, etc. will reduce number of bits available for actual data communication.

#### Digital voice for clear audio

The IDAS radio uses the AMBE+2™ codec providing crisp and clear communication and simultaneous data communication.

#### Selective call, group call and talk group ID

The IDAS system allows you to call individual or group users. The talk group ID shows group ID, unit ID or alias name on the display while receiving\* a message.

\* This function is similar to the analog mode PTT ID function, however, the IDAS radio can keep sending ID information during a voice transmission, so the receiving IDAS radio can decode the ID even when breaking into a conversation. (Late entry is possible)

#### Digital voice encryption

The IDAS system provides secure communication using a 15-bit key (about 32,000 keys) encryption.

#### RAN (Radio Access Number) for digital code squelch

The RAN code provides a digital code for accessing the IDAS repeater or digital code squelch function.

#### Network interface



#### Other functions (Subscriber units only)

- Status call/request
- Call alert
- Emergency call
- Remote radio monitor
  - ... Remotely turns on the PTT and transmits anything the microphone hears for a preprogrammed time period.
- Data call
  - ... send and receive a data communication
- Simultaneous data call
  - ... Send and receive data such as GPS position information with a voice transmission
- Radio check
- Remote radio stun/kill/revive
- Call log

## REPEATER FEATURES

### 25W, 50W versions, high duty cycle operation

Employing an effective cooling fan and high performance power amplifier, the IC-FR5000/FR6000 provides a stable 50W at 50% duty operation, and 25W output at 100% duty operation.

### 19-inch rack mount, 2U height low profile design

The IC-FR5000 series has a rack mount bracket and handles for installation in an industry standard 19-inch rack. A 2U height configuration allows you to stack multiple units in a rack.

### Two RF modules in one unit

The IC-FR5000 series has an internal space for installing another RF unit, the optional UR-FR5000 series. Two RF modules can be installed in the chassis and reduces installation space, while the RF modules can be programmed and operated independently.



Two RF units can be installed in the unit. (Left side is an option.)

### Multiple-table

The IC-FR5000 series detects multiple CTCSS, DTCS tone and digital RAN (Radio Access Number) codes on a channel (up to 16 tones/codes on a table) and downlinks (transmits) the received signal with a specified tone. This function is useful for sharing a channel with multiple groups and provides quiet standby while using other groups.



### 5-Tone encoder/decoder

When a preprogrammed 5-tone signal is received, the IC-FR5000 series starts and/or finishes repeater operation (downlinking).

### D-SUB 25-pin accessory connector

The IC-FR5000 series has a D-SUB 25-pin accessory connector for connecting LTR™/PassPort™ trunking\* controllers or other external devices. An operating channel can be controlled by the input signal from the D-SUB 25-pin connector. \* Analog mode only.

### Dot matrix, multi-function LCD

A dot matrix LCD is employed for the function display. Up to 12 characters can be displayed. There are 5 programmable buttons on the front panel allowing you to use the repeater as a base station.

### 32 memory channels

The IC-FR5000 series has 32 memory channels. Each memory channel stores a 12-character channel name, digital/analog channel spacing, repeater/base operation etc, as well as frequency setting.

### Voice scrambler

The IC-FR5000 series has a built-in inversion type\* voice scrambler. When a more secure voice scrambler system is required, the optional UT-109R/UT-110R\* is also available.

\* The inversion type voice scrambler and UT-109R/UT-110R voice scrambler is for analog mode only.

### CW ID transmission function\*

Own CW ID code or callsign can be sent at preprogrammed intervals. The ID code can be used for identifying the repeater. \* Analog mode transmission only.

### Other features

- Audio compander reduces background noise
- Wide frequency coverage (136–174MHz, 400–470MHz and 450–520MHz)
- High frequency stability ( $\pm 0.5\text{ppm}$ )
- PTT priority setting (Local mic, External PTT or Repeater operation)
- Low voltage alert
- Convenient key assign stickers supplied

**6.25kHz Digital mode ready\***

The IC-FR5000/FR6000 series are 6.25kHz digital mode ready\*, the IC-FR5000/FR6000 series provides 6.25kHz digital narrow mode communication, and increases efficiency of channel allocation and use of spectrum.

\*For the USA version digital mode is turned ON, for the EXP version it is turned OFF when shipped from the factory. Please ask your dealer for details.

**Background**

As existing spectrum becomes increasingly scarce, the demand for more options grows. The FCC essentially created additional spectrum by adding hundreds of new licenses with 6.25 kHz bandwidth. To take advantage of this opportunity, Icom and Kenwood entered into a joint agreement to develop 6.25 kHz technology. This technology is a new digital communications protocol that provides quality voice and data, and is designed as a non-proprietary protocol. It accomplishes this by using 4LFSK (4-Level Frequency Shift Keying) and FDMA (Frequency Division Multiple Access).

**History**

This technology was developed in response to an FCC revision of the rules concerning transmitters in the 150MHz to 174MHz and 421MHz to 512MHz range. To receive FCC certification after January 1<sup>st</sup> 2005, transmitters must have proved compliant as a multi-mode device. This requirement could be achieved by using 6.25 kHz channel bandwidth. In addition to the FCC requirement, Europe and Japan are also moving toward 6.25 kHz technologies. Because some in the industry believed that this requirement could not be met by 2005, the FCC suspended this requirement. (A new deadline of January 1<sup>st</sup> 2011 has been set.)

Icom, however, went ahead to meet this requirement. It was impossible to do using analog technology, so it became necessary to develop a new digital protocol.

Other methods were also considered, including ACSB and the proposed APCO Project 25 Phase II CQPSK. However, both required a more expensive linear amplifier in the transmitter and neither is compatible with existing analog FM hardware.

Instead, 4LFSK modulation was selected using FDMA for transmission. This method has a number of advantages:

- better communication range
- simpler design
- easy to maintain and service
- lower cost for business and industry customers
- compatible with existing FM radio hardware

Icom's first radio with this technology is the F3061/F4061. To enable backwards compatibility, the radio is both analog and digital and also works in 25 kHz and 12.5 kHz channel bandwidths (conventional and LTR™ trunked operation in analog mode).

This new digital protocol, NXDN™ (Next Generation Digital Narrowband) has been registered as a trademark by Icom Inc. and Kenwood Corporation. IDAS (Icom Digital Advanced System) is the system based on this NXDN™ technology.

The product range is steadily expanding , from handheld transceivers to mobile transceivers to repeaters. All products are/will be available for VHF and UHF bands.





Icom's has implemented this technology in the FR5000/6000 series. Backwards compatibility to analog only radios enables a planned migration path to "digital" with existing radios operating analog only and new radios operating analog and digital.

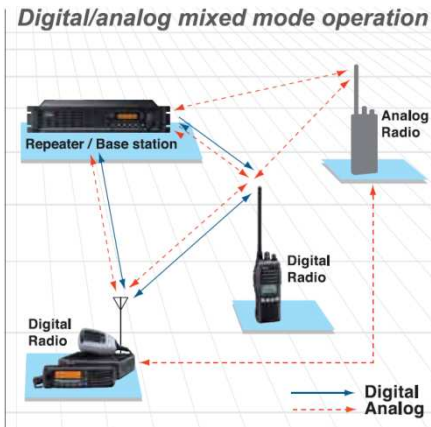

**General specifications:**

- Access Method : FDMA
- Transmission Rate : 4800 bps
- Modulation : 4-level FSK
- Vocoder : AMBE+2™
- Codec Rate : 3600 (Voice 2,450 + Error Correction 1,150 bps)

Modulation with 4LFSK uses a symbol mapping scheme. When the radio receives a binary number, that number is mapped to a symbol, which is interpreted as a 1050Hz frequency deviation. The deviation is detected, filtered and "unmapped" as a binary signal for transmission.

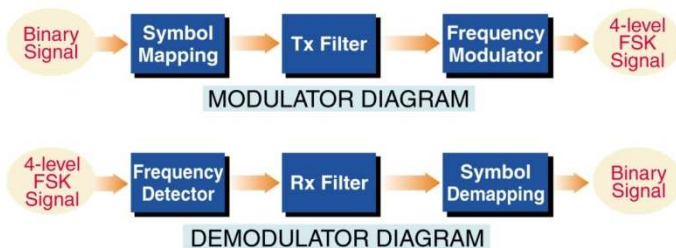

**Range**

Audio quality over distance is also greatly improved with Icom's 6.25 kHz technology. Instead of the early degradation of audio that you see in an analog signal, the 6.25 kHz digital audio quality remains higher over a comparable distance.

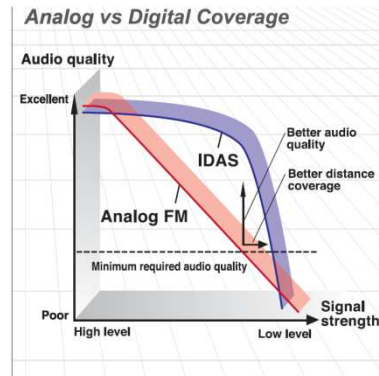

**Spectrum Considerations (VHF & UHF)\***

While most users are operating on 25 kHz channels, they will have to migrate to 12.5 kHz bandwidth by 2013. Narrowband migration has not succeeded until now, because of any incentive to do so.

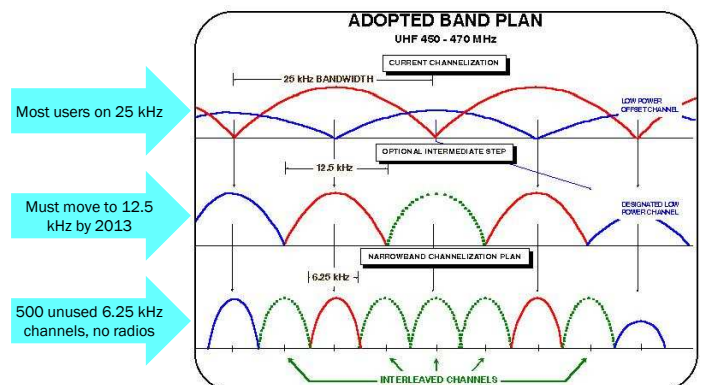

A channel is defined by the deviation either side of the center line frequency. Migrating from a 25 kHz channel to a 12.5 kHz channel on the same centerline frequency is a 1-for-1 move. There is no increase in the capacity to load radio users.

There are 500 new 6.25 kHz frequencies (VHF and UHF) available now. Most are unused because no 6.25 kHz radios were available. With Icom's FDMA technology, frequency coordinators have total flexibility to either assign a 6.25 kHz channel within an existing 25 kHz or 12.5 kHz channel or as a stand-alone frequency somewhere else on the band. A frequency coordinator will coordinate channels for minimum adjacent channel interference.

\* Some of the content above applies to the U.S.A. only.

Because the emission mask is tight, 6.25 kHz channels can be used next to each other without causing interference. The bandwidth measurements below show the 6.25kHz FDMA signal meets the FCC designated emission mask requirements.

The figure on the left is the emission mask for a 6.25 kHz channel. The Icom 6.25kHz FDMA signal clearly operates within the mask. Accordingly, the FCC certified the F3061/4061 as the first ever 6.25 kHz radio.

The figure on the right is the emission mask for a 12.5 kHz channel. With a 12.5 kHz channel, you can create two offset 6.25 kHz channels.

### 6.25 kHz channel

Occupied bandwidth DIGITAL

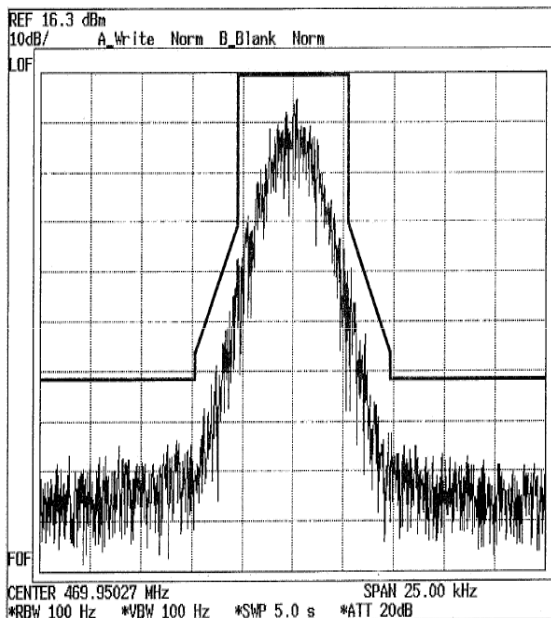

TEST FREQUENCY 469.95MHz (CH15) DIGITAL 6.25kHz  
 Carrier output power 5W  
 0dB with reference to level of unmodulated carrier

### 12.5 kHz channel

Occupied bandwidth DIGITAL

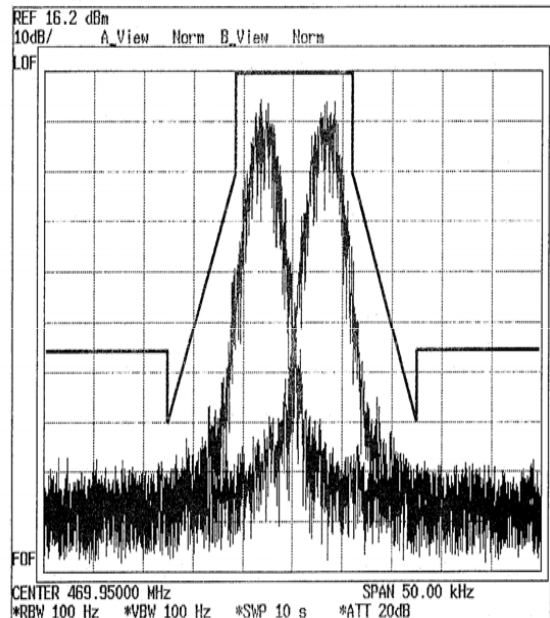

TEST FREQUENCY 469.95MHz +/- 3.125kHz (CH23, CH24)  
 Carrier output power 5W  
 0dB with reference to level of unmodulated carrier

6.25 kHz FDMA makes twice the number of channels available within the same spectrum as shown below. This is a real solution to meet expanding demand for spectrum every year.



12.5kHz Analog FM



6.25kHz FDMA

**NOTE:** The double capacity example shown above may not apply to some countries depending on local regulations.

### UHF Considerations\*

A number of frequency allocation options for 6.25 kHz are available in UHF.

**Note:** the following options illustrate potential spectrum opportunities with 6.25 kHz technology. Actual opportunities may vary by locale and other conditions. Please check with your frequency coordinator for opportunities available in your location.

### Obtain New 6.25 kHz Frequencies

This may be the best option for a new radio user in a location where no channels are available. Each 6.25 kHz frequency is unique. Existing 25 kHz or 12.5 kHz channels do not have to be “split.” This gives the greatest flexibility to the frequency coordinator.

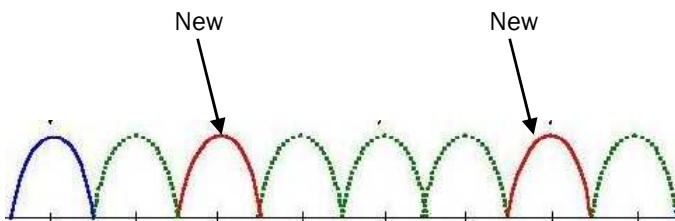

### Expand an Existing System

Spectrum holders can apply for some new additional 6.25 kHz channels and combine them with their current 25 or 12.5 kHz channels. New frequencies could occupy the existing 25 kHz or 12.5 kHz bandwidth. Additional stand-alone 6.25 kHz channels could also be used.

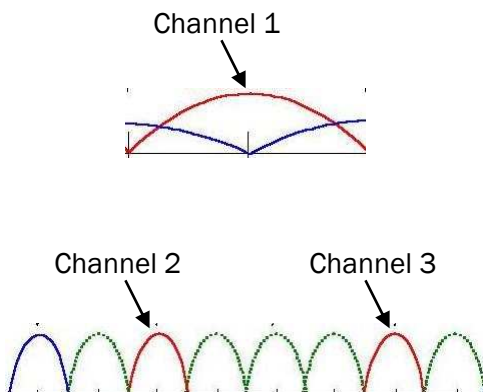

\* Some of the content above applies to the U.S.A. only.

### Split a 25 kHz or 12.5 kHz Channel

Both 2-for-1 and 4-for-1 efficiencies may be realized by splitting existing channels. Using 6.25 kHz channels offset from the center of a 25 kHz channel, it is possible to fit four 6.25 kHz channels into the 25 kHz bandwidth. To do this, a waiver from the FCC is required\*. Using this scheme, the four frequencies are now offset 3.125 kHz from the original 25 kHz channel center frequency.

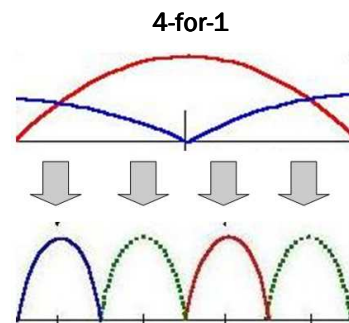

With a 12.5 kHz channel, you can create two offset 6.25 kHz channels.

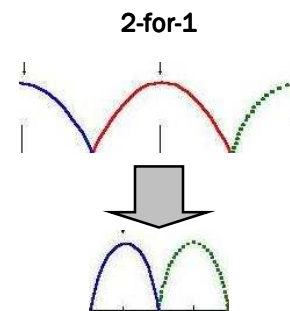

\*Note: No waiver needed if a 12.5 kHz channel is exclusive (FB8), under part [90.173(j)]

### Hedge Strategy

If you start at the center frequency, you can license 5 each 6.25 kHz frequencies underlying a 25 kHz channel. The 2 outer frequencies are out of the 25 kHz channel width. This provides license holders with a “hedge” against losing that spectrum in 2013 when they will be forced to 12.5 kHz.

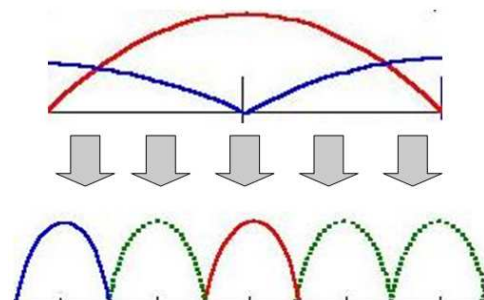

## VHF Considerations\*

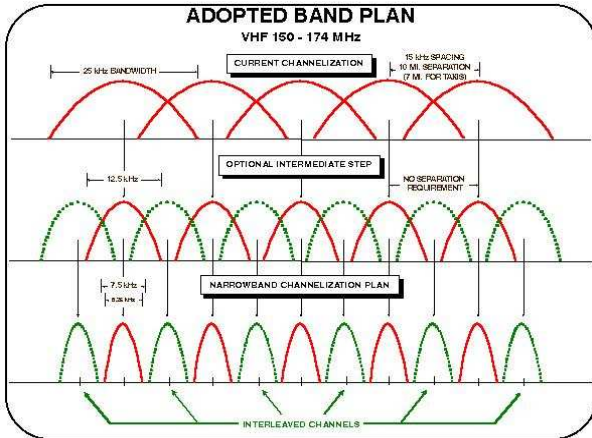

VHF offers even more opportunities due to its original 30 kHz channel width plan. When the FCC moved to 25 kHz and then 12.5 kHz an overlap was created requiring geographical separation between two contiguous channels. For example, 3 contiguous could not be used at the same location.

The VHF narrowband plan is 7.5 kHz channels, which has eliminated the geographical separation requirement. Tests have proven the Icom 6.25 kHz signal can be used within a 7.5 kHz channel with no interference to the adjacent channel.

### Split a 25 kHz or 12.5 kHz Channel

This is similar to the UHF application. With a 12.5 or 25 kHz channel, you can create two or four offset 6.25 kHz channels. This may require a waiver from the FCC.

### One 25 kHz Channel to Three 6.25 kHz Channels

A single 25 kHz channel can be converted to three 6.25 kHz channels, each operating within a 7.5 kHz channel.

\* Some of the content above applies to the U.S.A. only.

## Future Applications for 6.25kHz Technology

This new digital land mobile technology can be a platform for future integration of IT/IP/VOIP technologies. To this end, there are some initiatives between a number of manufacturers to promote 6.25kHz technology more widely. An example is the formation of the dPMR MoU in Europe, and the FCC in the U.S.A. has recently proposed that system owners consider switching to 6.25kHz technology where possible. Japan and China are also considering 6.25kHz for future digital radio standards.

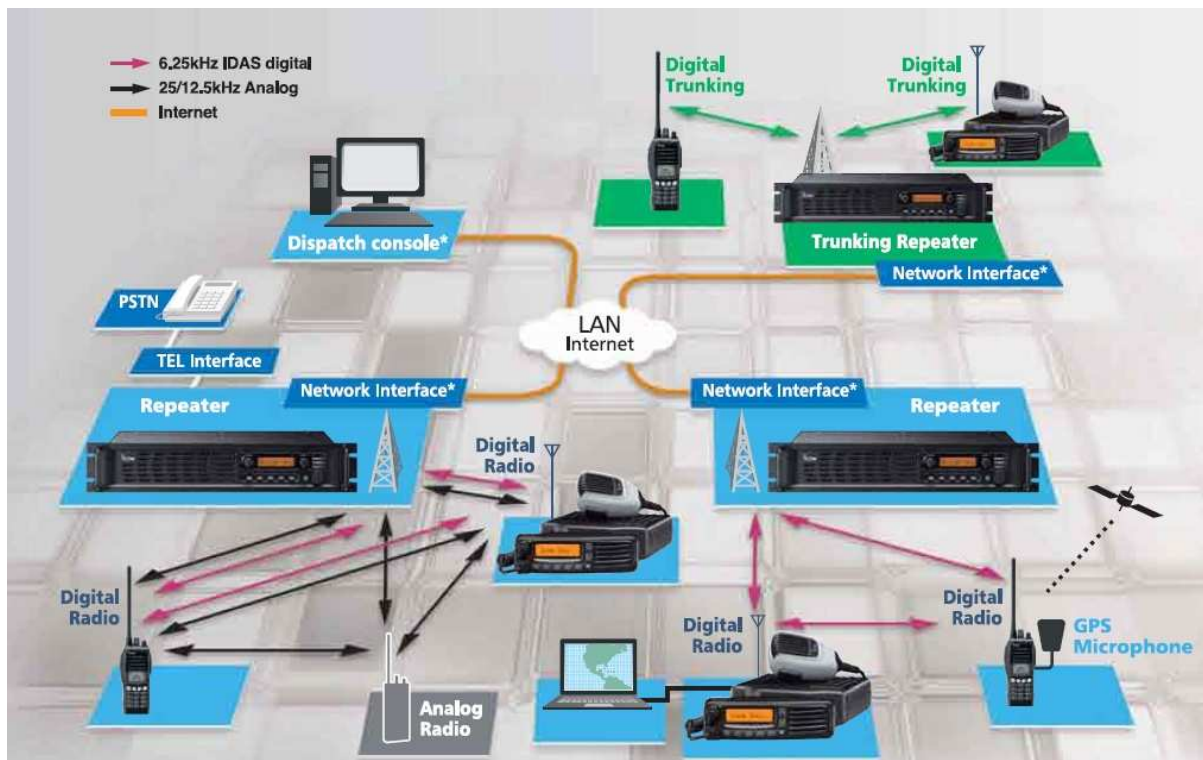

The above system is an image only.

## 2-4 Function and Specifications

### 2-4-1 VHF FM Repeaters

Model No.	IC-FR5000		IC-FR5000	
Version	#01		#03	
Destinations	USA-01		EXP-01	
Type Approval	FCC		Local T/A	
Function Comparison				
CTCSS	✓		✓	
DTCS	✓		✓	
2-Tone				
5-Tone	✓		✓	
DTMF Autodial	✓		✓	
DTMF Decoder	✓		✓	
BIIS 1200				
MDC 1200				
6.25kHz digital	✓		Note * <sup>1</sup>	
MPT 1327				
LTR™ Trunking				
PassPort™				
Intrinsically Safe				
SPECIFICATIONS				
GENERAL	Frequency Range (MHz)		136 ~ 174	
	Number of channels		32 Ch	
	Channel Spacing (kHz)		6.25/12.5/25, 7.5/15/30	
	PLL channel step (Unit: kHz)		2.5, 3.125	
	Power supply requirement		13.6V DC (Negative ground)	
	Current drain	Tx	50W	15A
		Rx	Stand-by	500mA (typ.), 400mA(FAN,LCD backlight off)
			Max. audio	1900mA (typ.)
	Dimensions (W × H × D) (projections not included)		483 × 88 × 260mm 19 <sup>1</sup> / <sub>32</sub> × 3 <sup>15</sup> / <sub>32</sub> × 10 <sup>1</sup> / <sub>4</sub> in	
	Weight (approx.)		5.6kg; 12.3lb	
TX	RF output power (High)		50W (25W at 100% duty cycle)	
	Spurious emissions		80dB (typ.)	
	Adjacent channel power		Wide 76 dB (typ.), Narrow 69dB (typ.), Digital 65 dB (typ.)	
RX	Sensitivity		Wide/Narrow 0.3μV (typ.) at 12dB SINAD Digital 0.25μV (typ.) at 5% BER	
	Adjacent channel selectivity		Wide 80 dB (typ.), Narrow 56 dB (typ.), Digital 63 dB (typ.)	
	Spurious response		90dB (typ)	
	Intermodulation rejection		78dB (typ)	
	Audio output power		4W (typ.) at 5% distortion with a 4Ω load	

Specifications are measured in accordance with TIA-603-B (for Wide and Narrow) or EN 300 166 (Digital) for IC-FR5000  
All stated specifications are subject to change without notice or obligation.

Note \*<sup>1</sup>: 6.25kHz digital capability can be turned ON if required.

Model No.	IC-FR6000	IC-FR6000	IC-FR6000	IC-FR6000		
Version	#01	#11	#03	#13		
Destinations	USA-01	USA-02	EXP-01	EXP-02		
Type Approval	FCC	FCC	Local T/A	Local T/A		
Function Comparison						
CTCSS	✓	✓	✓	✓		
DTCS	✓	✓	✓	✓		
2-Tone						
5-Tone	✓	✓	✓	✓		
DTMF Autodial	✓	✓	✓	✓		
DTMF Decoder	✓	✓	✓	✓		
BIIS 1200						
MDC 1200						
6.25kHz digital	✓	✓	Note *1	Note *1		
MPT 1327						
LTR™ Trunking						
PassPort™						
Intrinsically Safe						
SPECIFICATIONS						
GENERAL	Frequency Range (MHz)	400 ~ 470	450 ~ 520	400 ~ 470	450 ~ 520	
	Number of channels	32 Ch				
	Channel Spacing (kHz)	6.25/12.5/25		6.25* <sup>1</sup> /12.5/25		
	PLL channel step (Unit: kHz)	2.5, 3.125				
	Power supply requirement	13.6V DC (Negative ground)				
	Current drain	Tx	50W			
		Rx	Stand-by	15A		
			Max. audio	500mA (typ.), 400mA(FAN,LCD backlight off)		
	Dimensions (W × H × D) (projections not included)	483 × 88 × 260mm 19 <sup>1</sup> / <sub>32</sub> × 3 <sup>15</sup> / <sub>32</sub> × 10 <sup>1</sup> / <sub>4</sub> in				
	Weight (approx.)	5.6kg; 12.3lb				
TX	RF output power (High)	50W (25W at 100% duty cycle)				
	Spurious emissions	80dB (typ.)				
	Adjacent channel power	Wide 73 dB (typ.), Narrow 67dB (typ.), Digital 65 dB (typ.)				
RX	Sensitivity	Wide/Narrow 0.3μV (typ.) at 12dB SINAD, Digital 0.25μV (typ.) at 5% BER				
	Adjacent channel selectivity	Wide 78 dB (typ.), Narrow 56 dB (typ.), Digital 63 dB (typ.)				
	Spurious response	90dB (typ.)				
	Intermodulation rejection	78dB (typ.)				
	Audio output power	4W (typ.) at 5% distortion with a 4Ω load				

Specifications are measured in accordance with TIA-603-B (for Wide and Narrow) or EN 300 166 (Digital) for IC-FR6000  
 All stated specifications are subject to change without notice or obligation.

Note \*1: 6.25kHz digital capability can be turned ON if required.

\* Some optional accessories are not available in some countries.

EXTERNAL SPEAKERS		
 <p><b>SP-5</b> : Large external speaker. Input impedance : 4 Ω Max. input power : 5 W</p>	 <p><b>SP-10</b> : Mid sized external speaker. Input impedance : 4 Ω Max. input power : 5 W</p>	 <p><b>SP-22</b> : Compact and easy-to-install external speaker. Input impedance : 4 Ω Max. input power : 5 W</p>
HAND MICROPHONES	DESKTOP MICROPHONE	INTERNAL UNITS
 <p><b>HM-152</b> : Regular hand microphone.</p>	 <p><b>SM-25</b> : Convenient for dispatching, equipped with monitor switch.</p>	 <p><b>UT-109R</b> : Voice scrambler unit Non-rolling type (max. 32 codes).</p>  <p><b>UT-110R</b> : Voice scrambler unit Rolling type (max. 1020 codes).</p>
CHANNEL EXTENSION	CLONING CABLE	CLONING SOFTWARE
 <ul style="list-style-type: none"> <li>• <b>UR-FR6000</b> UHF CHANNEL MODULE 400–470MHz, 450–520MHz, 50W</li> <li>• <b>UR-FR5000</b> VHF CHANNEL MODULE 136–174MHz, 50W</li> </ul>	 <p><b>OPC-1122U</b> : CLONING CABLE (USB type) Consist of;</p> <ul style="list-style-type: none"> <li>• OPC-1122U 250mm</li> <li>• OPC-1637 (USB cable) 1500mm</li> <li>• CD (USB driver software)</li> </ul>	<p><b>CS-FR5000</b> : For programming versions of the IC-FR5000/FR6000 series VHF/UHF FM REPEATERS.</p>

## ❑ Unpacking

After unpacking, immediately report any damage to the delivering carrier or dealer. Keep the shipping cartons.

For a description and a diagram of accessory equipment included with the IC-FR5000/FR6000 series, see 'Supplied accessories' on page 5 of this handbook.

## ❑ Selecting a location

Select a location for the repeater that allows adequate air circulation, free from extreme heat, cold, or vibrations, and away from TV sets, TV antenna elements, radios and other electromagnetic sources.

## ❑ Antenna connection

For radio communications, the antenna is of critical importance, along with output power and sensitivity. Select antenna(s), such as a well-matched 50 Ω antenna, and feedline. 1.5:1 or better of Voltage Standing Wave Ratio (VSWR) is recommended for the desired band. Of course, the transmission line should be a coaxial cable.

**CAUTION:** Protect repeater from lightning by using a lightning arrestor.

**NOTE:** There are many publications covering proper antennas and their installation. Check with your local dealer for more information and recommendations

## ❑ Front panel connections

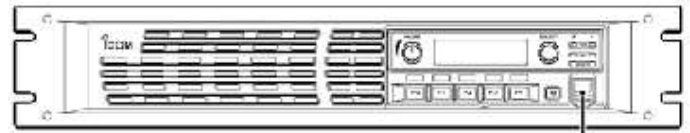

### MICROPHONE CONNECTOR (Front panel view)

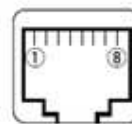

- ① +8 V DC output (Max. 10 mA)
- ② Output port for PC programming
- ③ NC
- ④ M PTT (Input port for TX control)
- ⑤ Microphone ground
- ⑥ Microphone input
- ⑦ Ground
- ⑧ Input port for PC programming

**CAUTION: DO NOT** short pin 1 to ground as this can damage the internal 8 V regulator. DC voltage is applied to pin 1 for microphone operation. Only Icom microphones are recommended.

**HM-152 HAND MICROPHONE**  
(optional)



**SM-25 DESKTOP MICROPHONE**  
(optional)



## TYPE-N CONNECTOR INSTALLATION EXAMPLE

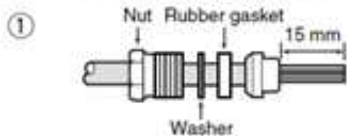

Slide the nut, flat washer, rubber gasket and clamp over the coaxial cable, then cut the end of the cable evenly.

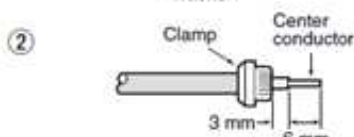

Strip the cable and fold the braid back over the clamp.



Soft solder the center conductor. Install the center conductor pin and solder it.

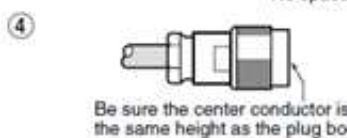

Carefully slide the plug body into place aligning the center conductor pin on the cable. Tighten the nut onto the plug body.

15 mm (19/32 in) 6 mm (1/4 in) 3 mm (1/8 in)



## ❑ Rear panel connections

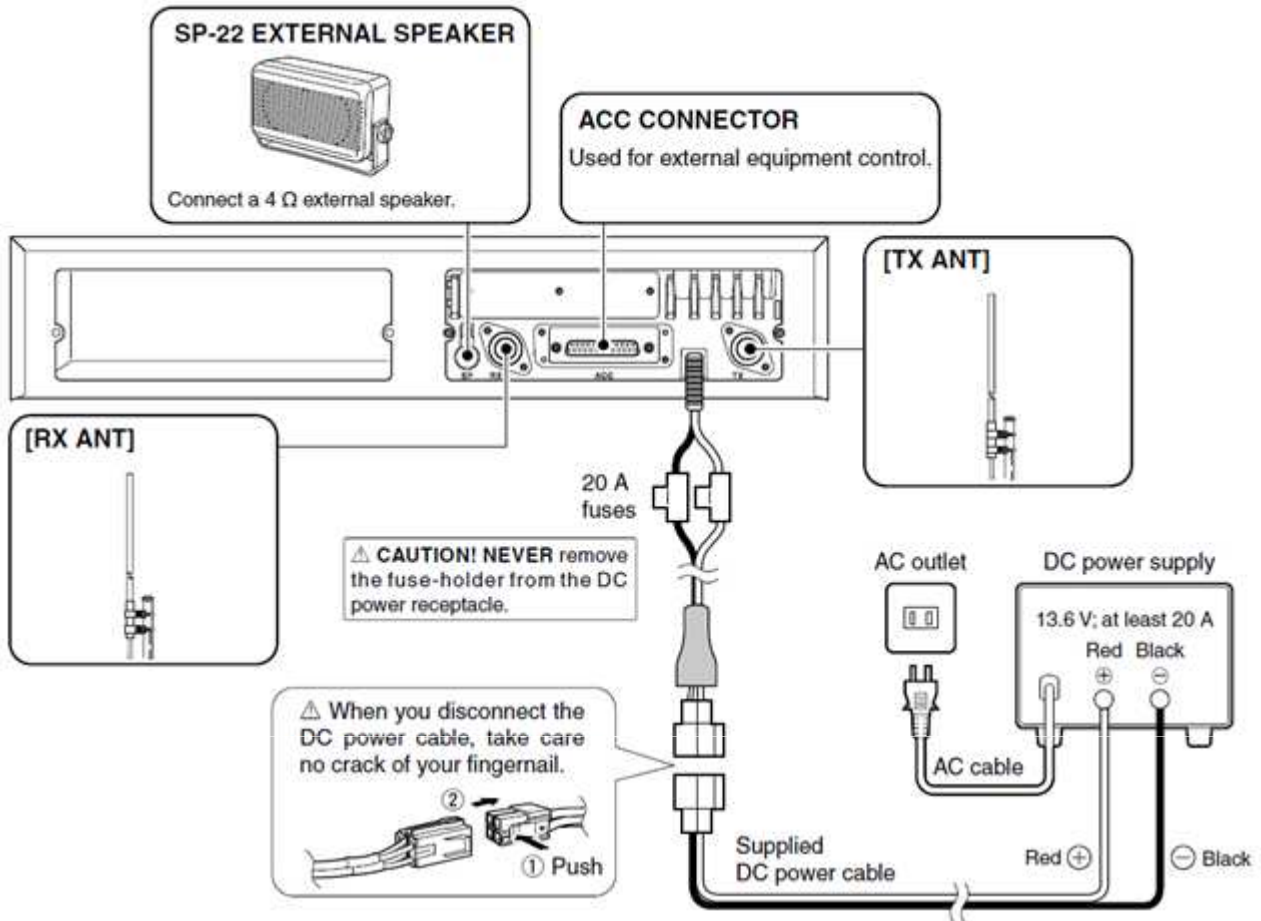

## ❑ Power supply connection

Make sure the repeater's power is turned OFF when connecting a DC power cable.

**CAUTION:** Voltages greater than 16 V DC will damage the repeater. Check the source voltage before connecting the power cable.

## ❑ Mounting the repeater

### ◇ Using the supplied handle

The supplied handles are available for mounting the repeater into a 19 inch rack. The handles can be installed to the repeater's front panel.

- ① Attach the supplied handles to both sides of the repeater's front panel with the spacers, then tighten the screws as below.

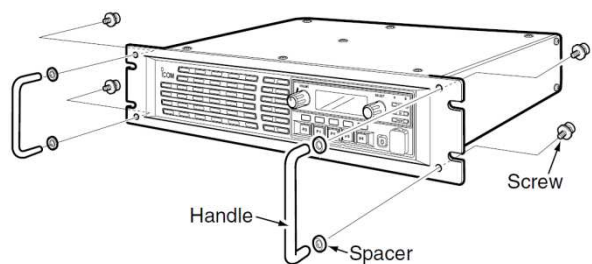

- ② The completed installation should look like as below.

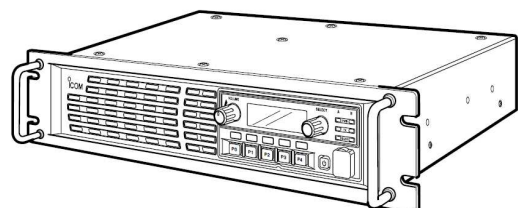

## □ UR-FR5000/UR-FR6000 CHANNEL EXTENSION MODULES

### SUPPLIED ACCESSORIES

- ① DC power cable ..... 1
- ② Control cable ..... 1
- ③ Angles ..... 2
- ④ Screws (M4 × 8 mm) ..... 4
- ⑤ Set screws (M3 × 6 mm) ..... 4
- ⑥ Tapping screws (M3 × 8 mm) ..... 2

1 mm = 1/32 inch

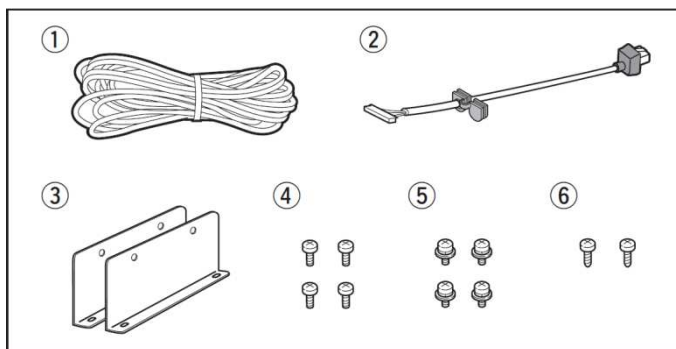

### OPENING CASE

① Remove 7 screws from top and 2 screws each from both sides of the repeater, then slide off the top cover to the direction of the arrow as illustrated below.

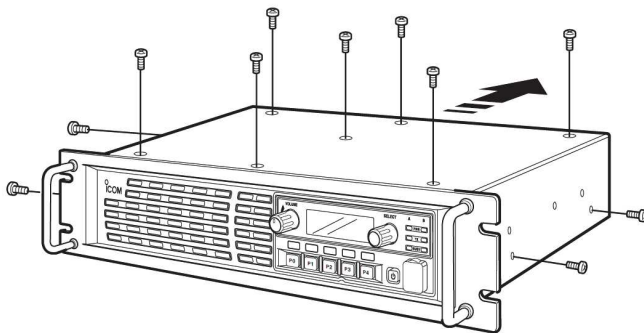

② Remove 3 screws from bottom and 2 screws each from both sides of the repeater.

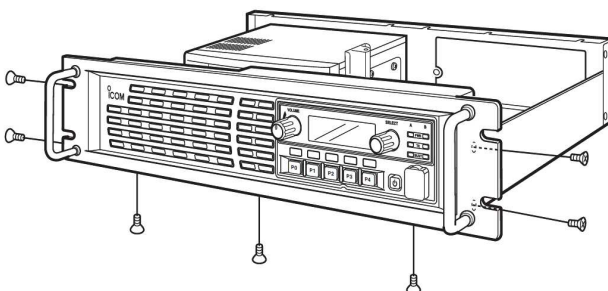

③ Disconnect the control cable from the channel module (original), then remove the front panel.

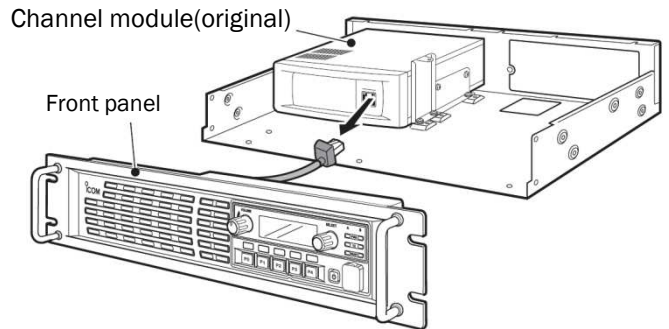

④ Remove 6 screws from the front panel, then remove the shielding plate and rubber seal.

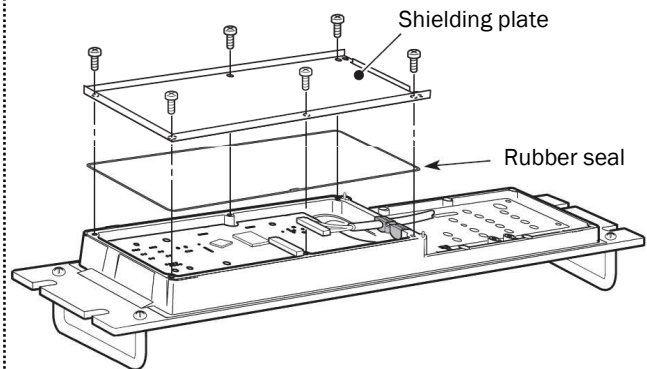

## INSTALLATION

- Install the UR-FR5000 or UR-FR6000(channel extension module)

① Attach the supplied angles to both sides of the channel extension module, and tighten the 2 supplied screws (M4 × 8) on each side.

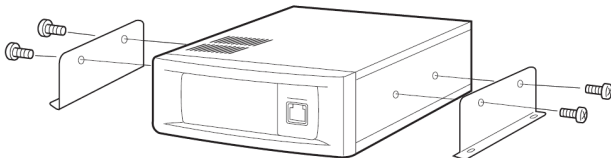

② Install the channel extension module using the supplied screws (Tapping screws: M3 × 8, Set screws: M3 × 6) as shown below.

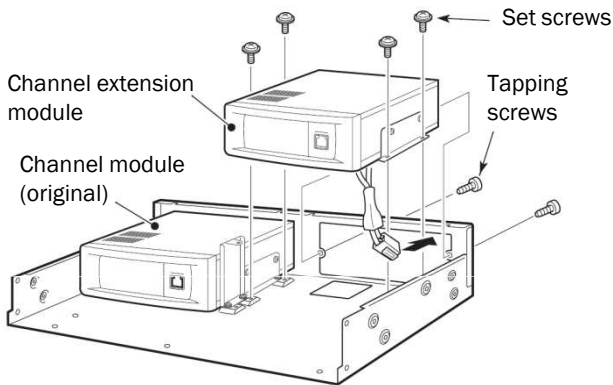

- Connect the control cable

① Connect the supplied control cable to J502 on the front board as shown below.  
 ② Cut the rubber caps of the control cables, then insert the rubber caps to the front panel's chassis as shown below.

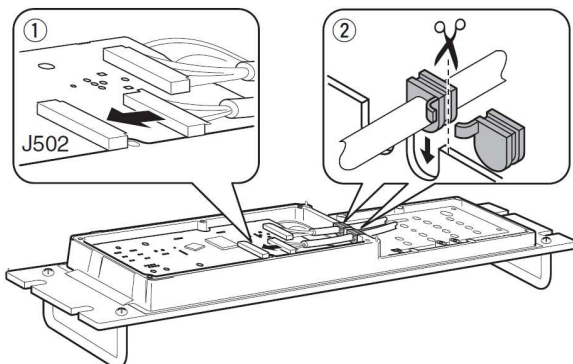

## ASSEMBLE THE UNIT

① Replace the rubber seal and shielding plate of the front panel, then tighten the 6 screws.

- Make sure the rubber seal is properly seated in the groove of the chassis.
- Be sure to match the correct positions of the holes of the shielding plate and projections of the front panel's chassis.

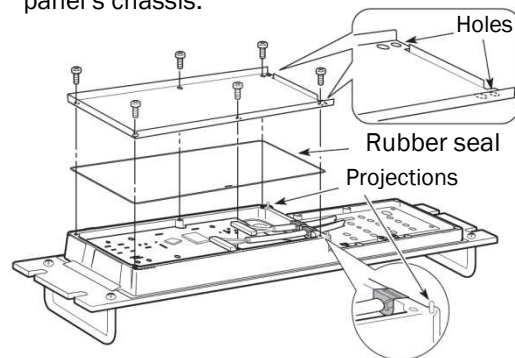

② Connect the control cables to the channel modules.

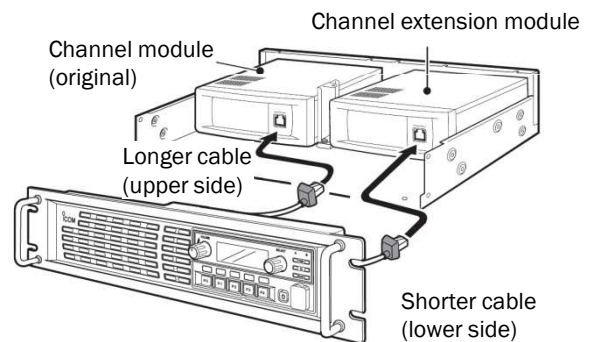

③ Return the front panel, top cover and screws to their original positions.

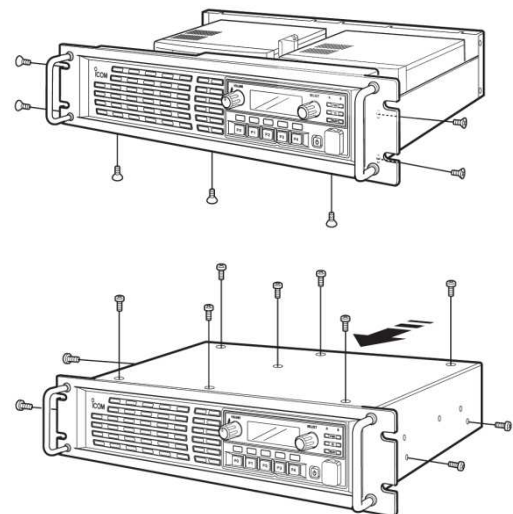

Note: Operation of the functions described below may depend on repeater programming.

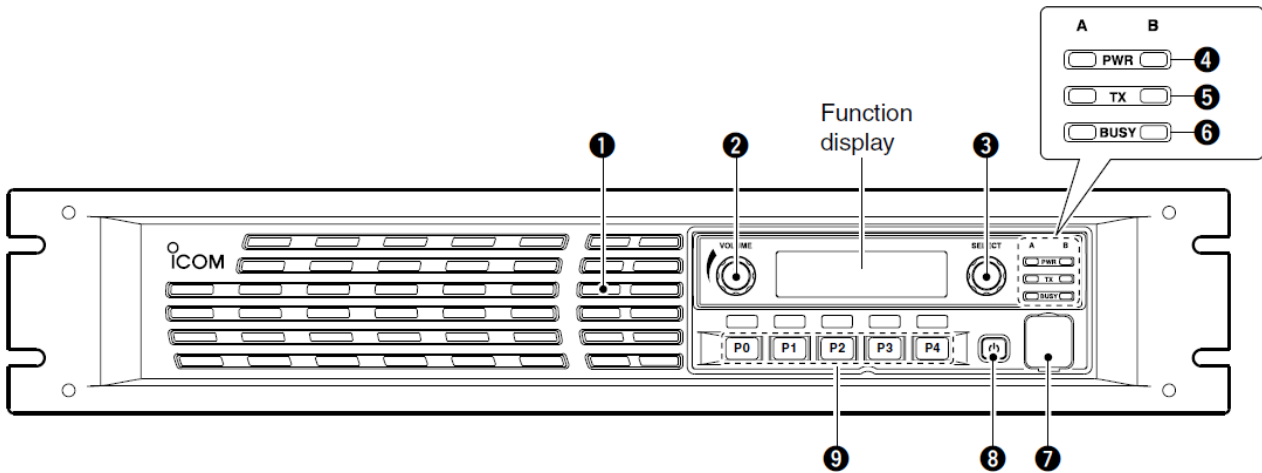

### ① INTERNAL SPEAKER

Monitors received signals.

### ② VOLUME CONTROL [VOLUME]

Adjusts the audio output level.

### ③ SELECTOR DIAL [SELECT]

Rotate to adjust the squelch threshold level, select the operating channel. (Depending on the pre-programmed condition.)

### ④ POWER INDICATOR [POWER]

➤ Lights green at 'A' module's indicator while the repeater power is turned ON.

#### When a channel extension module is installed:

- Light green at the selected module indicator ('A' or 'B') while the repeater power is turned ON.
- Lights orange at the un-selected module indicator ('A' or 'B') while the repeater power is turned ON.

### ⑤ TRANSMIT INDICATOR [TX]

Lights red while transmitting.

### ⑥ BUSY INDICATOR [BUSY]

Lights green while receiving a signal or when the noise squelch is open.

#### About [PWR], [TX] and [BUSY] indicator:

'A' and 'B' modules indicators are available for these indications. 'A' module's indicator corresponds to the original module, and 'B' module's indicator corresponds to an extended module.

### ⑦ MICROPHONE/SPEAKER CONNECTOR [MIC/SP]

This 8-pin modular jack accepts the optional microphone.

**KEEP** the [MIC] connector cover attached to the repeater when the optional microphones is not used.

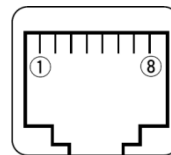

- ① +8 V DC output (Max. 15 mA)
- ② I/O port for PC programming
- ③ NC
- ④ M PTT (Input port for TX control)
- ⑤ Microphone ground
- ⑥ Microphone input
- ⑦ Ground
- ⑧ M MONI (Input port for monitor control)

### ⑧ POWER SWITCH [POWER]

- Push to turn the repeater power ON.
- Push and hold for 3 sec. to turn the repeater power OFF.

#### When a channel extension module is installed:

- While the repeater power is turned ON, push to select the desired module to operate the repeater as the base station.
  - The power indicator of the selected module unit lights green.

### ⑨ DEALER-PROGRAMMABLE KEYS

Desired functions can be programmed independently by your dealer.

Ask your dealer for details.

- Because these keys are programmable, the functions of these keys are unique to each unit.

## ➤ Function display

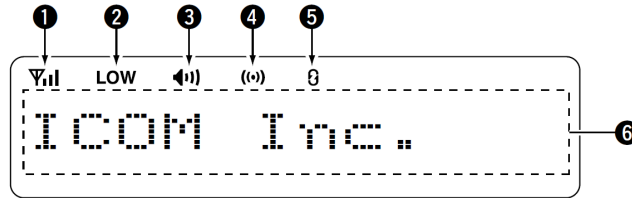

### ① SIGNAL STRENGTH INDICATOR

Indicates relative signal strength level.

### ② LOW POWER INDICATOR

Appears when low output power is selected.

### ③ AUDIBLE INDICATOR

Appears when the channel is in the 'audible' (unmute) condition.

### ④ COMPANDER INDICATOR

Appears when the compander function is activated.

### ⑤ SCRAMBLER/ENCRYPTION INDICATOR

Appears when the voice scrambler/encryption function is activated.

### ⑥ ALPHANUMERIC DISPLAY

Shows a variety of text or code information.

## ☐ Rear panel

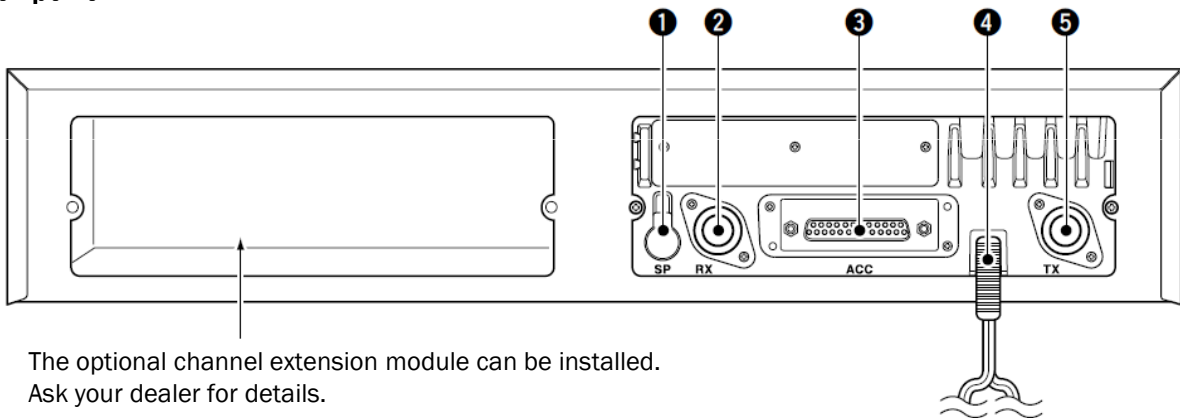

The optional channel extension module can be installed.  
Ask your dealer for details.

### ① EXTERNAL SPEAKER CONNECTOR [SP]

Connect the optional SP-22.

### ② RECEIVE ANTENNA CONNECTOR [RX]

Connects a receive antenna (impedance: 50 Ω).

### ③ ACCESSORY CONNECTOR [ACC]

Connects to the accessory connector.

- See pgs. 25 for accessory connector information.

### ④ DC POWER RECEPTACLE

Connects the supplied DC power cable from this connector to an external 13.6 V DC power supply.

### ⑤ TRANSMIT ANTENNA CONNECTOR [TX]

Connects a transmit antenna (impedance: 50 Ω) and outputs transmit signals.

## 4-1-1 Functions Programmable to Assignable Keys

### □ Key Assign

Assign a function to each programmable key; [Dial]/[P0]/[P1]/[P2]/[P3] and [P4]. The functions you can assign to [DIAL] are limited.

#### For [Dial]

Key & Display Assign	
Key	Conventional
Dial	CH Up/Down
P0	Null
P1	CH Up/Down
P2	SQL Level Up/Down
P3	Null
P4	Null

- **Null**  
No function.
- **CH Up/Down**  
Rotate to select a channel after selecting a specific function via other keys.[DIAL].
- **SQL Level Up/Down** Rotate to select SQL level.

#### For [P0]/[P1]/[P2]/[P3] and [P4]

Key & Display Assign	
Key	Conventional
Dial	CH Up/Down
P0	Null
P1	Null
P2	CH Up
P3	CH Down
P4	Scan A Start/Stop
	Scan B Start/Stop
	Scan Add/Del(Tag)
	Prio A
	Prio A (Rewrite)
	Prio B
	Prio B (Rewrite)
	MR-CH 1
	MR-CH 2
	MR-CH 3
	MR-CH 4
	Moni
	Light
	Lock
	High/Low
	Wide/Narrow
	Scrambler/Encryption
	Compander
	Hook Scan
	User Set Mode
	OPT1 Out
	OPT2 Out
	OPT3 Out
	OPT1 Momentary
	OPT2 Momentary
	OPT3 Momentary
	Ext.CH Sel Mode

- **Null**  
No function.
- **CH Up/Down**  
Push to select a channel after selecting a specific function via other keys.

- **Scan A Start/Stop**  
- This key operation depends on Power ON Scan setting in the Common screen.

**When Power ON scan function is turned "OFF";**  
Push to start and cancel scanning operation.

**When Power ON scan function is turned "ON";**  
Push to pause scanning, then resumes scanning after passing the time period specified in **Auto Reset Timer**.

- Push and hold this key for 1 sec. to indicate the scan group, then push [CH Up] or [CH Down] to select the desired group.

- **Scan B Start/Stop**  
- Push to start and cancel scanning operation. Scan resumes after passing the time period specified in **Auto Reset Timer** when scan is canceled except for this key.  
- Push and hold this key for 1 sec. to indicate the scan group, then push [CH Up] or [CH Down] to select the desired group.

- **Scan Add/Del (Tag)**  
- The channel can be added or deleted to/from the selected scanning list.
  1. Push to indicate the scan list, then push [CH Up] or [CH Down] to select the desired list.
  2. Push to add or delete the channel to/from the selected scanning list.
  3. Push and hold for 1 sec. to exit the scan list selection mode.

- Push this key while scan is paused (a signal is detected) on a channel (except for primary or secondary channel), the channel is cleared from the scan list.  
When **Nuisance Delete** is turned "ON" in Scan Setting screen, the cleared channel is added to the scan list again after the scan is canceled.

- **Prio A, Prio B**  
Push to select priority A/B channel programmed in **Atr** in the Memory CH screen respectively.

- **Prio A (Rewrite), Prio B (Rewrite)**

- Push to select priority A/B channel programmed in **Atr** in the Memory CH screen.
- Push for 1 sec. to reassign the operating channel for priority A/B channel.

- **MR-CH 1/2/3/4**

- Push to select memory channels 1 to 4.

- **Moni**

- Push to open any squelches/deactivate any mutes.

- **Light**

- Push to turn the backlight ON for about 5 sec. when **Backlight** is turned "OFF" in Set Mode screen.

- **Lock**

- Push and hold for 1 sec. to toggle the key lock function ON and OFF.
- When this function is assigned to any programmable key, the key lock function is turned "ON" when 1min. has passed without any key operation.

- **High/Low**

- Push to toggle transmit output power level from the independent settings of each channel.
- The selectable level is specified according to the **RF Pwr** setting in the Memory CH screen.
- The [High/Low] selects Low1 only when "Low1" is selected in **RF Pwr**.
- The [High/Low] toggles output power level between Low1 and Low2 when "Low2" is selected in **RF Pwr**.
- The [High/Low] toggles output power level between Low1, Low2 and High when "High" is selected in **RF Pwr**.

- **Wide/Narrow**

- Push to toggle "Wide" or "Narrow" channel spacing operation for both transmission and reception temporarily. Once the channel is changed, the bandwidth returns to the original setting.
- The original bandwidth is programmed in **Wide/Narrow** in the Memory CH screen.

- **Scrambler/Encryption**

- Push to toggle the voice scrambler/encryption function ON and OFF.

- **Compander**

- Push to turn the compander function ON and OFF.
- The compander function reduces noise components from the transmitting audio to provide clear communication.

- **Hook Scan**

- When the **On Hook (Scan)** function is turned "ON" in the Key & Display Assign screen, push this key to disable On Hook (Scan) function temporarily.
- Push this key again to enable On Hook (Scan) function.

- **User Set Mode**

- Push and hold for 1 sec. to enter the User Set Mode.
- The User Set Mode is used for programming infrequently changed values or conditions of functions without PC programming.
- Push this key momentarily to select the function, and push [CH Up] or [CH Down] to change the setting, after entering into the User Set Mode.
- Push and hold for 1 sec. to exit the User Set Mode.

- **OPT1/2/3 Out**

- This key's function is exclusive for use with non-Icom units.
- When [OPT 1/2/3 Out] is selected, active level selection (H or L) screen will appear so that the correct setting is made for the connected unit.
- \* Option connectors inside the repeater have 3 ports each for these outputs.
- OPT1/2/3 outputs the selected active level H or L when this key is pushed.

- **OPT1/2/3 Momentary**

- This key's function is exclusive for use with non-Icom units.
- When [OPT 1/2/3 Momentary] is selected, active level selection (H or L) screen will appear so that the correct setting is made for the connected unit.
- \* Option connectors inside the repeater have 3 ports each for these outputs.
- OPT1/2/3 outputs the selected active level H or L while this key is pushed.

- **Ext.CH Sel Mode**

- Push to toggle the MCH Select function ON and OFF.
- When the MCH Select function is turned "ON", you can move to the desired memory channel with the External I/O operation only.
- Assign MCH Select function to the **D-Sub 25 pin-Function** in the Port Setting screen and the desired memory channel to the **Ext CH No.** in the CH Switch Table screen.

- When the MCH Select function is turned "OFF", you can move to the desired memory channel without the External I/O operation.

□ **Display**

• **Opening Text**

Enter up to a 12-character repeater opening message to appear on the LCD for 2 sec. when turning the repeater ON.  
Set this item as blank for no indication when turning the repeater ON.

• **Opening Beep** (Available only when **Opening Text** is programmed as above)

Set the opening beep function to emit a beep when the opening text is displayed on the LCD.

<b>OFF</b>	Beep emission (or non emission) is retained even when the opening text is displayed on the LCD.
<b>Short</b>	1 high beep "Pi" is emitted once.
<b>Long</b>	A long beep sound is emitted during the time the opening text is displayed on the LCD.

• **Label**

Enter the desired up to a 12-character Label.  
When "Label" or "MR CH + Label" is selected in **Display Mode**, the programmed label will be indicated on the LCD.

• **Display Mode**

Select the display indication from MR CH, Label, or MR CH + Label.

<b>MR CH</b>	The display indicates the selected memory channel's programmed text. When no text is programmed, indicates the memory channel number.
<b>Label</b>	The display indicates the programmed label in <b>Label</b> as above. When no label is programmed, indicates the selected operating channel number or programmed text.
<b>MR CH + Label</b>	The display indicates the programmed label in <b>Label</b> as above and the programmed text. When no label is programmed, indicates the selected operating channel number or programmed text.

**Text setting for Opening Text and Label**

Right click to display the [Edit... Enter] menu and click [Edit... Enter].

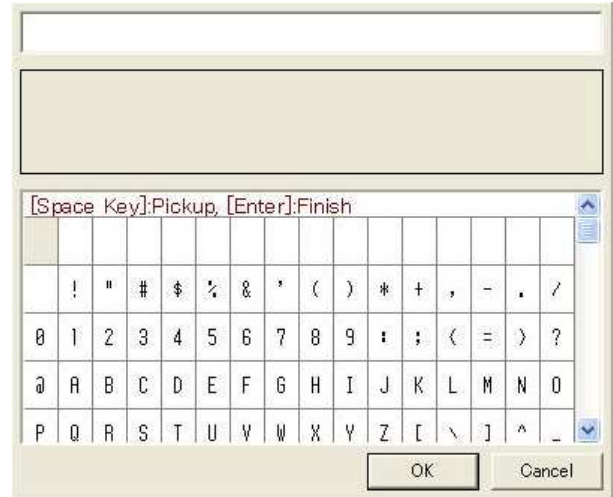

- Double click the desired character in the table or push [Space] to pick up the character.
- Push [Enter] to finish editing.

Usable characters are listed below.

	!	"	#	\$	%	&	'	(	)	*	+	,	-	.	/
0	1	2	3	4	5	6	7	8	9	:	;	<	=	>	?
@	A	B	C	D	E	F	G	H	I	J	K	L	M	N	O
P	Q	R	S	T	U	V	W	X	Y	Z	[	\	]	^	_
\	a	b	c	d	e	f	g	h	i	j	k	l	m	n	o
p	q	r	s	t	u	v	w	x	y	z	{		}	~	Δ
!	!	!	!	!	-	-	-	■	■	■	■	▶	◀	▲	▼
Б	Г	Д	Ж	З	И	Й	Л	П	У	Ф	Х	Ц	Ш	Щ	Ъ
!	!	!	!	!	!	!	!	!	!	!	!	!	!	!	!
°	±	²	³		μ	¶	.		ı	º	»	¼	½	¾	¿
À	Á	Â	Ã	Ä	Å	Æ	Ç	È	É	Ê	Ë	Ì	Í	Î	Ï
Ð	Ñ	Ò	Ó	Ô	Õ	Ö	×	Ø	Ù	Ú	Û	Ü	Ý	Þ	ß
à	á	â	ã	ä	å	æ	ç	è	é	ê	ë	ì	í	î	ï
ð	ñ	ò	ó	ô	õ	ö	÷	ø	ù	ú	û	ü	ý	þ	ÿ

- You can use and make an original character that is edited in the [Character Editor](#) Screen.



### □ Accessory connector

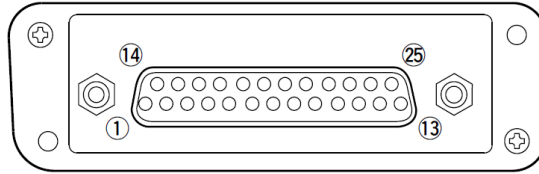

Pin No.	Pin Name	Description	Specification
1	NC	No connection	—
2	TXD	Output terminal for serial communication data.	—
3	RXD	Input terminal for serial communication data.	—
4	RTS	Output terminal for request-to-send data.	—
5	CTS	Input terminal for clear-to-send data.	—
6	NC	No connection	—
7	GND	Serial/digital signal ground	—
8	MOD IN	Modulator input from an external terminal unit.	Input level: 300 mV rms
9	DISC OUT	Output terminal for AF signals from the AF detector circuit. Output level is fixed, regardless of [AF] control.	Output level: 300 mV rms
10	EXT. D/A	The desired function can be assigned.* (Default: Null)	—
11	VCC	13.6 V DC output	Output current: Less than 1 A
12	EXT. A/D	Customize A/D input (Not used)	—
13	NC	No connection	—
14	GND	Ground	—
15	EXT.I/O 15	The desired function can be assigned.* (Default: Null)	+5 V pull up, Active=L
16	EXT.I/O 16	The desired function can be assigned.* (Default: P0 Monitor Output)	+5 V pull up, Active=L
17	EXT.I/O 17	The desired function can be assigned.* (Default: Busy Output)	+5 V pull up, Active=L
18	EXT.I/O 18	The desired function can be assigned.* (Default: Null)	+5 V pull up, Active=L
19	EXT.I/O 19	The desired function can be assigned.* (Default: EPTT Input)	+5 V pull up, Active=L
20	DATA IN	Input terminal for data.	—
21	EXT.I/O 21	The desired function can be assigned.* (Default: Analog Audible Output)	+5 V pull up, Active=L
22	AF OUT	The AF detector Output.	—
23	EXT.I/O 23	The desired function can be assigned.* (Default: Mic Mute Output)	+5 V pull up, Active=L
24	EXT.I/O 24	The desired function can be assigned.* (Default: Null)	+5 V pull up, Active=L
25	EXT.I/O 25	The desired function can be assigned.* (Default: Mic Hanger Output)	+5 V pull up, Active=L

\* The desired function can be assigned using the optional CS-FR5000 cloning software. Ask your dealer for details.

**Port Setting** : Assign a function to each port;

For [Ext.I/O 15 to 25]

• **In/Out**

Select the type of the assignable function from Input and Output.

• **Active Logic** (Available when "Output" is selected In/Out as above)

Select the active logic for the D-sub 25 pin output from High and Low.

**Function-When "Input" is selected in In/Out**

• **Null**

No function.

• **MCH Select : 1/2/3/4/5**

You can select the desired memory channel with the function. Activate the desired MCH Selects assigned ports to make the Ext CH No. You can make the Ext CH No. one of the 32 pre-programmed memory channels. (see table below) [0]: Hi-Z, [1]: 0 V

MCH Select : 1	+ 1 CH
MCH Select : 2	+ 2 CH
MCH Select : 3	+ 4 CH
MCH Select : 4	+ 8 CH
MCH Select : 5	+ 16 CH

CH	MCH Select					CH	MCH Select				
	5	4	3	2	1		5	4	3	2	1
1	0	0	0	0	0	17	1	0	0	0	0
2	0	0	0	0	1	18	1	0	0	0	1
3	0	0	0	1	0	19	1	0	0	1	0
4	0	0	0	1	1	20	1	0	0	1	1
5	0	0	1	0	0	21	1	0	1	0	0
6	0	0	1	0	1	22	1	0	1	0	1
7	0	0	1	1	0	23	1	0	1	1	0
8	0	0	1	1	1	24	1	0	1	1	1
9	0	1	0	0	0	25	1	1	0	0	0
10	0	1	0	0	1	26	1	1	0	0	1
11	0	1	0	1	0	27	1	1	0	1	0
12	0	1	0	1	1	28	1	1	0	1	1
13	0	1	1	0	0	29	1	1	1	0	0
14	0	1	1	0	1	30	1	1	1	0	1
15	0	1	1	1	0	31	1	1	1	1	0
16	0	1	1	1	1	32	1	1	1	1	1

• **EPTT**

When the port is activated, the Ext. PTT (EPTT) function is turned "ON".

• **Repeat Disable**

When the port is activated, the repeater operation is disabled.

• **TX Disable**

When the port is activated, the transmission is disabled.

• **Mic Mute**

When the port is activated, the connected microphone is muted.

• **Ext. Key**

You can use the port as the customized key. The same functions in the Key Assign are assignable to the port.

**Function-When "Output" is selected in In/Out**

• **Null**

No function.

• **Busy**

Acts when receiving a carrier signal that is stronger than the SQL level.

• **Analog Audible**

Acts when the mute is released by receiving an analog signal.

• **Digital Audible**

Acts when the mute is released by receiving a digital signal.

• **Mic Mute**

Acts while the connected microphone's mute is released.

• **Hanger**

Acts while the connected microphone is put down on its hanger (hanger-on).

• **PTT**

Acts while pushing the connected microphone's [PTT] or Ext.PTT (EPTT).

• **TX**

Acts while the repeater is transmitting.

• **Low Voltage 1/2**

Acts when the repeater's voltage is lower than the **Low Voltage 1/2** in the Common screen respectively.

• **Over Voltage**

Acts when the repeater's voltage is overvoltage.

• **Final Protect**

Acts when the final protect is activated.

• **Fan State**

Acts while the FAN works improperly.

• **RX/TX Unlock**

Acts while the RX/TX PLL is unlocked.

• **P0/1/2/3/4 Monitor**

Outputs the customized key (P0 to 4) condition when each key is pushed.

For [Ext. D/A 10]

The Analog Output port can output the Analog signal to the D/A port.

• **Null**

No function.

• **Power-supply Voltage**

Outputs the VIN (proportionate to the power-supply voltage).

• **Temperature**

Outputs the TEMPS (proportionate to the temperature).

• **RSSI**

Outputs the SD (proportionate to the received signal's RSSI voltage).

### □ Getting started

- This cloning software is designed to perform data setting and cloning for the IC-FR5000/IC-FR6000 series VHF/UHF FM REPEATERS.
- HELP WINDOW: CS-FR5000 has a help window to describe functions and operation.

### □ System requirements

To use this program, the following hardware and software are required:

#### PC

- Microsoft® Windows® 2000/XP or Microsoft® Windows Vista™ is installed
- With USB port

#### Other item

Optional OPC-1122U\* CLONING CABLE (USB type)

#### NOTE:

To use the OPC-1122U, USB type cloning cable, USB driver installation is necessary. The driver is supplied with the OPC-1122U. See the OPC-1122U instruction manual for the installation details.

\*The USB driver, supplied with the OPC-1122U, is not supported for Microsoft® Windows Vista™(64 bit).

### □ Software installation

- ① Quit all applications when Windows is running.
- ② Insert the CD into the appropriate CD drive.
- ③ Double-click the “Setup.exe” contained in the CD.
- ④ The “Welcome to the InstallShield Wizard for CS-FR5000” will appear as below. Click [Next>].

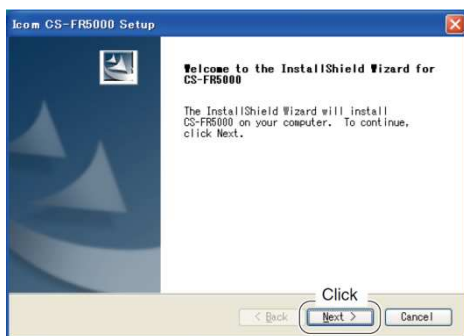

- ⑤ The “User Information” will appear as below, then type your name, your company name and the product ID number with the following manner. Then click [Next >].
  - ID number: 306401-(6 digit serial number)
  - e.g. the serial number on the CD is 000001, enter “306401-000001” as the ID number.

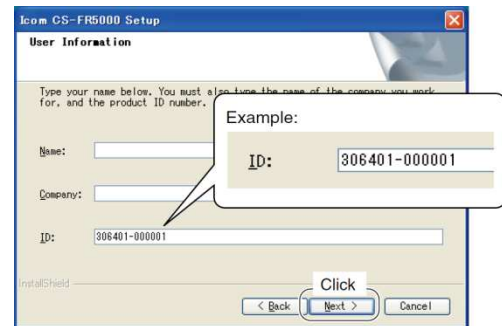

- ⑥ The “Choose Destination Location” will appear as below. Then click [Next>] to install the software to the destination folder. (e.g. C:\Program Files\Icom\CS-FR5000)
  - Click [Browse...] to select another destination folder before clicking [Next >], if desired.



- ⑦ After the installation is completed, the “InstallShield Wizard Complete” will appear as below. Then click [Finish].

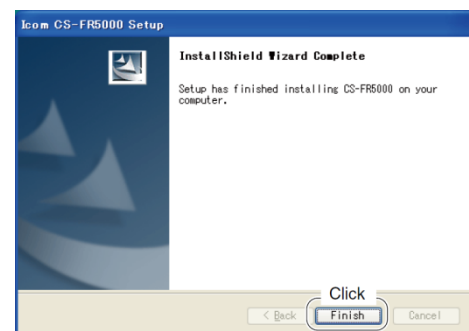

- ⑧ Eject the CD.
- ⑨ Program group ‘CS-FR5000’ appears in the ‘Programs’ folder of the start menu, and ‘CS-FR5000’ short cut icon appears on the desktop screen.
  - To uninstall the cloning software, select the “Control Panel” in the start menu, and click the “Add or Remove Programs.” Then, select the program group ‘Icom CS-FR5000’ and click [Remove].

Note 1: Icom distributes cloning software by CD or license. Depending on this, some information here may not apply as written, e.g. ID number.

## □ Connections

All cloning operations are performed from the computer's mouse or keyboard—the operation required on the receiver side is;

- ① First, connect the cloning cable as illustrated below.
- ② And then push [PWR] to turn power ON.

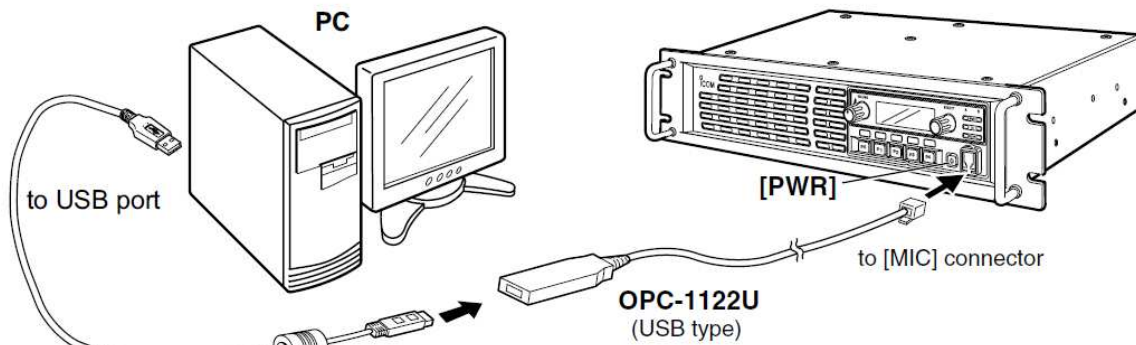

## □ Screen description

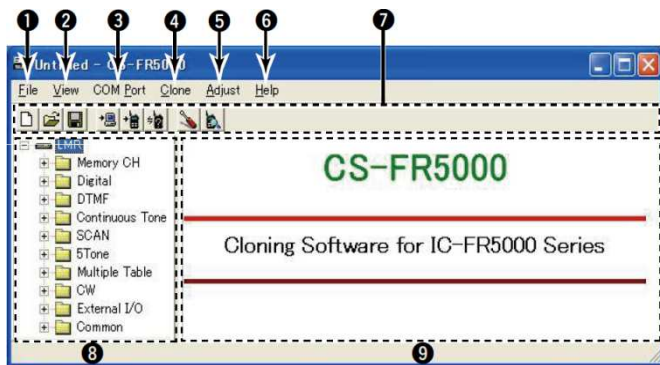

### ① FILE MENU [File]

Used for saving memory channel contents, printing the pre-programmed information or quitting the program, etc.

### ② VIEW MENU [View]

- Select the displayed font size and language.
- Turn the Toolbar/Status bar ON or OFF.

### ③ COM PORT MENU [COM Port]

- Click to display the COM port (1 to 4 and More) setting dialog box.
- Set the transfer speed (Normal or High).

**NOTE:** 'Check the following' dialog box appears when the COM port is not set correctly. Click to display cloning menu and cloning information dialog box.

### ④ CLONING MENU [Clone]

Click to display the cloning menu and cloning information dialog box.

### ⑤ ADJUST MENU [Adjust]

Click to display the adjust menu and the I/O Check dialog box.

### ⑥ HELP MENU [Help]

Click to display the help contents and cloning software revision information.

### ⑦ TOOL BAR

Shortcut buttons appear on the tool bar when the tool bar indication is turned ON in the [View] menu.

### ⑧ TREE VIEW SCREEN

Click the icon which you want to edit.

### ⑨ CONTENTS LIST SCREEN

Display the contents list.

## □ Programming information

- We recommend that you should read out all the repeater's data before start entering/editing parameters even when the repeater is factory fresh. This avoids rare glitches which might cause programming errors when writing back the altered parameters.
- Double click the desired cell in the contents list screen directory, or rightclick the cell to display the edit menu. Then click **[Edit... Enter]** to select and change the setting depends on the item.
- Click **[Help]** to display the help screen for the item.

Edit...	Enter
Copy	Ctrl+C
Paste	Ctrl+V
Up	Ctrl+Up
Down	Ctrl+Down
Clear	
Delete	Del
Insert	Ins
Help	

(Edit menu)

### ☐ Cloning items

#### Common Setting

##### ➤ Key & Display

Assign one of several functions to the Dealer assignable keys, set the beep audio frequency, Display conditions, Select the transmit output power etc.

##### ➤ Set Mode

For setting the following items in the repeater's user set mode to "Inhibit" or "Enable", and adjust the appropriate setting.

The items includes Backlight, LCD Contrast, Fan, Beep, SQL Level, AF Min Level, Mic Gain, Signal Moni, System info, LCD Check, Information, and Key Check.

##### ➤ Common

Commonly set items such as Clone Comment (1)/(2), Security, Auto Reset, TOT, Lockout, Repeater Hold Timer, PTT Encode Tone, EPPT Delay Timer, RS-232C, Scrambler, Low Voltage 1 and 2 value, Beat Cancel, Wide Band Width, Front Speaker, and Digital Function.

#### Memory CH

The 'Memory CH' window allow you to edit the channel information. Editable items such as RX/TX Frequency, Time-Out-Timer, Scan List, CW ID, TX C.Tone, Wide/Narrow, Compander, 5-Tone setting, Digital Setting, Scrambler/Encryption OFF/ON/Inhibit etc.

#### Digital\*

##### ➤ Individual ID List

Set the Individual ID within 0 to 65519, or 65535 and Enter up to a 12-character Individual ID name.

##### ➤ Encryption

A total of 63 encryption settings are available. Set the Encryption Key from 0001 to 7FFF (hexadecimal number) to each Encryption No.

##### ➤ ANI

Set the display condition of Talkgroup ID and Unit ID.

#### DTMF

##### ➤ DTMF Encode

Program a DTMF code up to 24 digits for acknowledgement.

##### ➤ DTMF Decode

Program a DTMF code up to 24 digits for DTMF decode operation.

##### ➤ DTMF Setting

Set PTT Delay, No tone Timer, \*# Timer, DTMF Timer, 1st Timer, ANI Display Timer, Decode with C. Tone, etc.

#### Continuous Tone

Set the Tone Burst, Tone Burst Timer, User CTCSS Freq, TX DTCS Inverse and RX DTCS Inverse.

\* Digital mode must be enabled for this functionality.

#### SCAN

##### ➤ Scan List

A total of 17 scanning lists are available for a wide variety and flexible scanning operation.

##### ➤ Scan Setting

Set the timer for Watch, Watch Unmatch, Resume, Talk Back, Fast Scan, Slow Scan, and set the functions such as Power ON Scan, Nuisance Delete, Mode Dependent Scan, Monitor Key Action, Talk Back Timer Beep.

#### 5Tone

##### ➤ RX Code CH

Set RX Code, text, ABC, Aud Mode, Emer, Beep, ext.

##### ➤ RX Code Setting

Set Link A Timer, Compare Digit, ID Decode Timer and Auto Timer.

##### ➤ TX Code CH

Set TX Code, Text, Input Digit, Update, ABC condition, and Sel.

##### ➤ TX Code Setting

Set Long Tone Timer, Link R/1/2 Timer, Lead Out Delay Timer, ABC Decode Timer, etc.

##### ➤ Format

Set the Tone Period for a tone encoder, Notone Timer and Tone Length.

##### ➤ User Tone

Set the encode tone frequency, the lower and higher edge of the tone decode frequency range. And check the 'Auto' check-box so that the recommended decode frequencies are automatically set.

#### Multiple Table

Enter up to 16 C.Tone and/or RAN code in each Multi Table.

#### CW

Program up to a 32-digit CW ID, Set the Interval time, select the Standard Word, set the CW speed etc.

#### External I/O

##### ➤ CH Switch Table

Assign the transceiver's memory channel to each Ext CH No.

##### ➤ Port Setting of D-Sub 25 pin

Assign a function to [Ext. I/O 15 to 25] and [Ext. D/A 10]

**NOTE:** The above instructions are for reference only. Please refer to the HELP file of the cloning software for the function or setting details.

## □ Receiving and transmitting

### ➤ Repeater operation

Ask your dealer for details of the repeater's programming.

- ➔ When the power is turned ON, the **[PWR]** indicator lights green.
- ➔ The **[TX]** and **[BUSY]** indicators light simultaneously while transmitting/receiving a signal.
  - The **[TX]** indicator lights red.
  - The **[BUSY]** indicator lights green.

### ➤ Base station operation

#### Receiving

- ① Push **[POWER]** to turn power ON.
- ② Set the audio and squelch levels.
  - ➔ Rotate **[SELECT]**\*<sup>1</sup> fully counterclockwise in advance.
  - ➔ Rotate **[VOLUME]** to adjust the audio output level.
  - ➔ Rotate **[SELECT]**\*<sup>1</sup> clockwise until the noise disappears.
- ③ Push **[CH Up]**\*<sup>2</sup> or **[CH Down]**\*<sup>2</sup> to select the desired channel.
  - When receiving a signal, the **[BUSY]** indicator lights green and audio is emitted from the speaker.
  - Further adjustment of **[VOLUME]** to a comfortable listening level may be necessary at this point.

\*<sup>1</sup>When the [SQL Level Up/Down] key function is assigned to [SELECT].

\*<sup>2</sup>When the [CH Up]/[CH Down] key functions are assigned.

#### Transmitting

- ① Take the microphone off hook.
- ② Wait for the channel to become clear.
- ③ Push and hold **[PTT]** to transmit, then speak into the microphone at your normal voice level.
- ④ Release **[PTT]** to receive.

#### IMPORTANT:

To maximize the audio quality of the transmitted signal:

- (1) Pause briefly after pushing **[PTT]**.
- (2) Hold the microphone 1 to 2 inch (2.5 to 5 cm) from your mouth, then speak into the microphone at a normal voice level.

\*Some function available in analog base station mode are not available in digital base station mode.

## ❑ Multiple table function

The IC-FR5000/FR6000 allows relaying between multiple groups with one repeater. (When group separation is carried out with a continuous tone)  
This feature can be used in both analog and digital mode.

### • Operation

- The C. Tone and/or RAN code is set for each group.
- When Group A is using the repeater, the other groups cannot use it.
- When the Group A relay is finished, the other groups can then use the repeater.

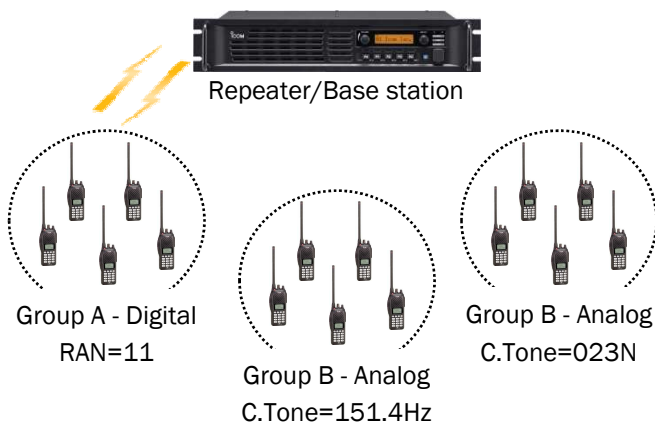

## ➤ Multiple table setup

Enter up to 16 C. Tone and/or RAN code in each Multi Table.

### • Table No.

Select the desired Multi Table No. within 1 to 16.  
When the number is selected in **Multi Table No.** in the Memory CH screen, the specified C. Tones and/or RAN codes are used as the encoder and decoder in the channel.

#### NOTE:

- When "Analog" is selected in **CH Type** in the Memory CH screen, only the assigned C. Tones are available.
- When "Digital" is selected in **CH Type** in the Memory CH screen, only the assigned RAN codes are available.

### • Type

Select the signaling type from Analog and Digital.

<b>Analog</b>	Desired CTCSS frequency or DTCS code can be set in <b>Decode</b> and <b>Encode</b> (FM mode operation).
<b>Digital</b>	Desired RAN code can be set in <b>Decode</b> and <b>Encode</b> (Digital mode operation).

### • Decode/Encode

Enter the desired C. Tone and/or RAN code for Decode and Encode columns respectively.

#### NOTE:

When "Simplex/Semi-Duplex" is selected in the **Operation Mode** in the Memory CH screen, only C. Tone and/or RAN code specified in Encode columns are used.

### When "Analog" is selected in Type

Select the desired CTCSS frequency from the list or enter a 3-digit DTCS code with polarity, N (Normal) or I (Inverse), for **Decode** and **Encode** respectively.

### When "Digital" is selected in Type

Set the desired RAN (Radio Access Number) from 00 to 63 (decimal number) to separate the repeater from the same/adjacent channel station according to the assigned code for **Decode** and **Encode** respectively.

The repeater selectively accesses the one of several repeaters within overlapping coverage areas allowing the user to listen to a specific repeater.

"00" (decimal number) is a special code, and matches to any RAN.

## ➤ Memory Channel setup

### • Operation Mode

Select the usage of the channel from Repeat, Full-Duplex and Simplex.

<b>Repeat :Repeat</b>	For repeater operation.
<b>Full-Duplex :Full-Duplex</b>	For base station operation in full-duplex mode.
<b>Simplex :Semi-Duplex/Simplex</b>	For base station operation in simplex mode.

#### NOTE:

When "Repeat" or "Full-Duplex" is selected, enter the different frequency in RX and TX columns.  
Otherwise, the setting cannot be activated correctly.

### • Multi Table No.

Select the desired Multi Table No. within 1 to 16 and OFF.

Up to 16 C. Tones and/or RAN codes assigned in the table can be decoded and encoded in the CH.

Multi Table setting in the Multiple Table screen must be specified to use the function.

#### NOTE:

- When "Analog" is selected in **CH Type**, only the assigned C. Tones in the selected Multi Table are available.
- When "Digital" is selected in **CH Type**, only the assigned RAN codes in the selected Multi Table are available.

## ❑ PC Command

The IC-FR6000 series has a D-SUB 25-pin accessory connector for connecting LTR™/PassPort™ trunking\* controllers or other external devices. An operating channel can be controlled by the input signal from the D-SUB 25-pin connector.

A PC command protocol is available to the manufacturers who produce external devices to control Icom transceivers and/or repeaters by signing an NDA.

## ➤ Connection



Connect the RS-232C terminal on PC and the D-Sub 25pin connector on the rear of IC-FR6000 by a cable.

## ➤ Setting of the Cloning Software

- Set the RS-232C mode at Common – Common – RS-232C  
Mode: MC CMD V2
- The Initial set up value of connection Speed is 4800bps. This can be changed to match the speed with the Terminal software.

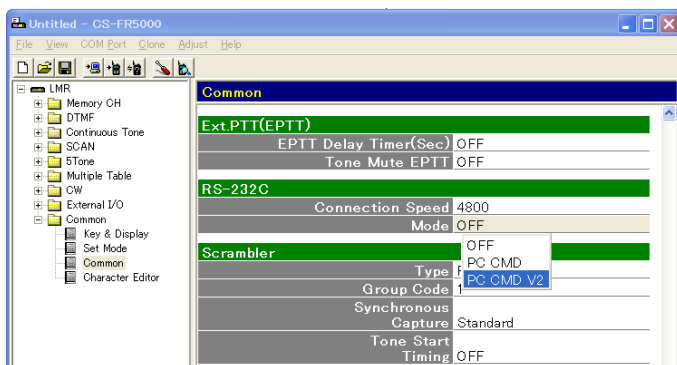

## ❑ Operation with a Hyper Terminal

The Hyper Terminal software comes with Windows® 2000 or Windows® XP. Hyper Terminal software is not supplied with Window Vista™.

## ➤ Hyper Terminal setup

### 1. Name and Icon setup

When starting the Hyper Terminal software the screen below will be displayed. Type a name and select an icon from the list then click the OK button.

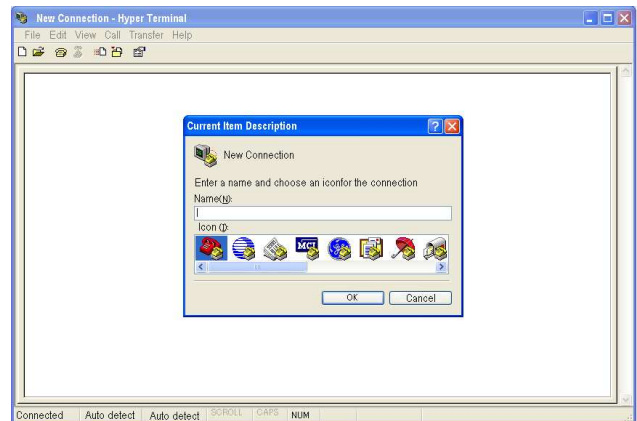

### 2. Set up PC and radio connection

- Select COM1 – COM2(255 max) of the “Connect using”.

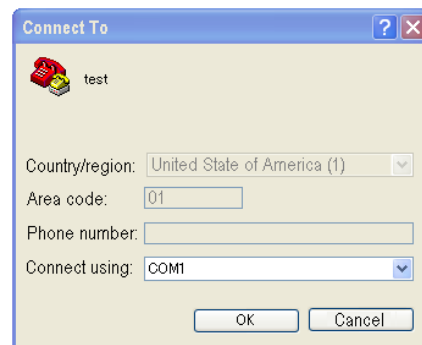

- Detail of COM port setup

**NOTE** Speed should be matched with cloning software settings.

Set each port setting parameter as below.

- Data=8bit
- Parity=None
- Stop=1bit
- Flow=None

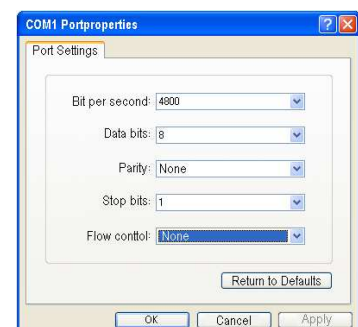



- Open the Properties window and select the Settings sheet then click ASCII Setup to open ASCII Setup window.

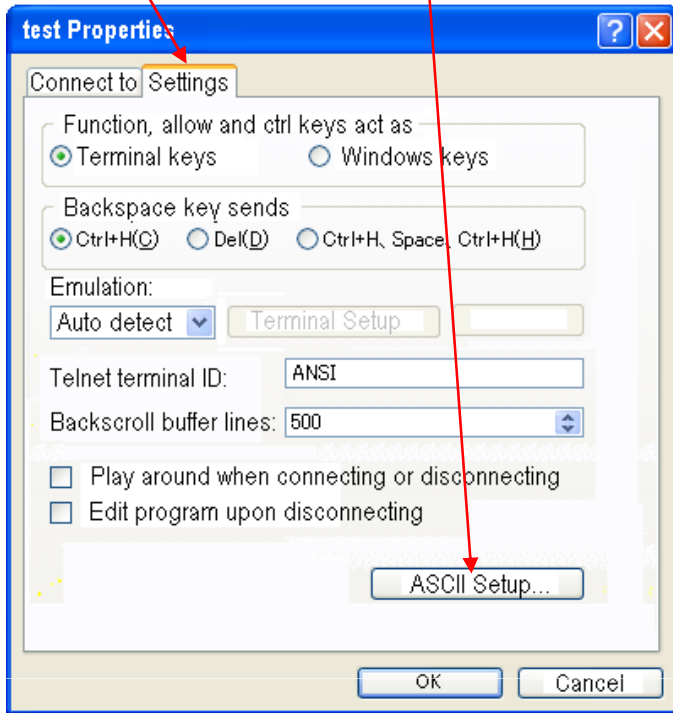

- Select Echo typed characters locally by clicking the checkbox.

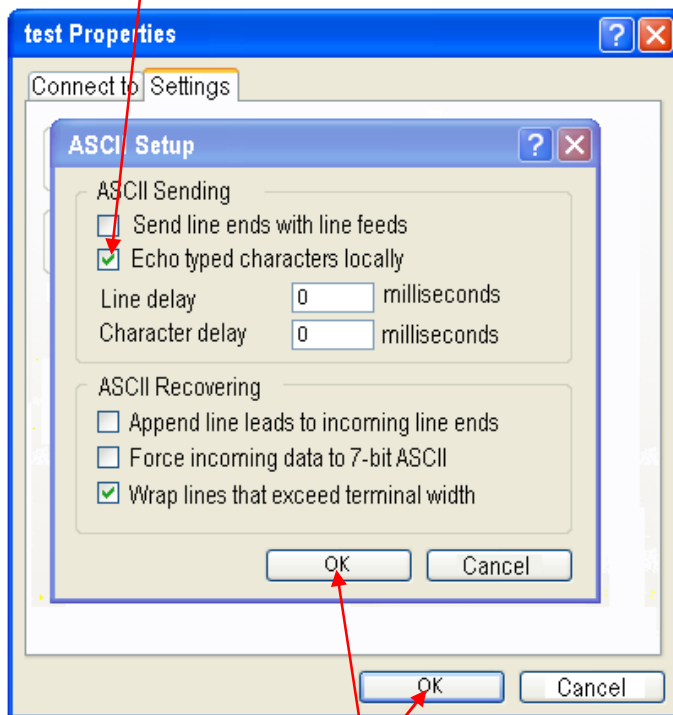

- Close the windows by click "OK" buttons.

## ➤ Operation

### Receiving the PC command

When the Hyper terminal software starts, it is always in receiving mode. With the PC and repeater connected, turn the repeater power ON. The following display appears.

[Memory ch=1], [Audible=off]

NOTE: For details, see the PC Command Expansion (V2) specification sheet.

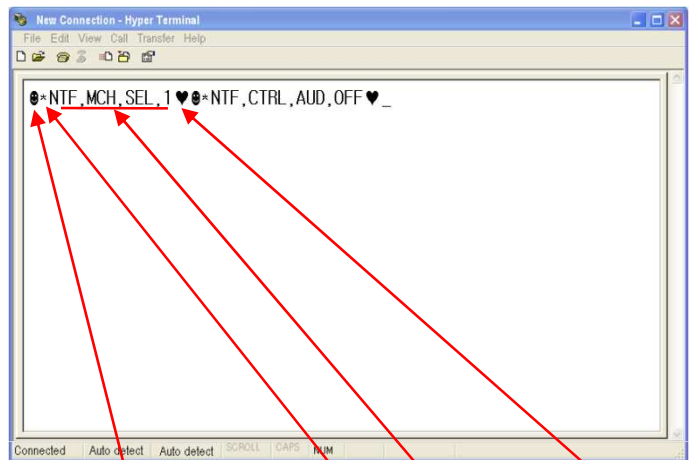

Start [STX] , V2 Command [\*] , COMMAND, Stop [EXT]

### Transmitting the PC command

Below is an example of reading the revision number from the radio.

COMMAND=GET, INFO, REV

Enter STX(CTRL+B) \* GET, INFO, REV ETX(CTRL+C) from PC then STX \* NTF, INFO, REV, 2.0, \$E73C EXT will be returned from radio.

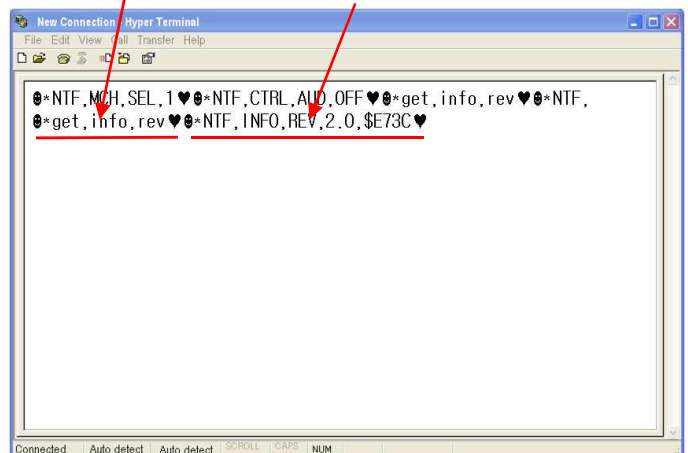

NOTE: Revision number and check sum differs by each radio.

### Scan List

A total of 16 scanning lists are available for a wide variety and flexible scanning operation. In this screen, program scanning condition for each list.

#### ➤ Display Text

Enter up to a 12-character text to indicate message, etc. and/or indicating the scan list during scanning.

#### ➤ Scan Type

Set the scanning type to each scan list. Scan OFF, Normal Scan and Priority Scan are available. The watch time period, the power ON scan function etc. is programmed in Scan Setting screen.

#### Scan OFF:

Scanning operation is turned OFF.

#### Normal Scan:

Normal scan. Scans all selected channels. The scan proceeds in sequence.

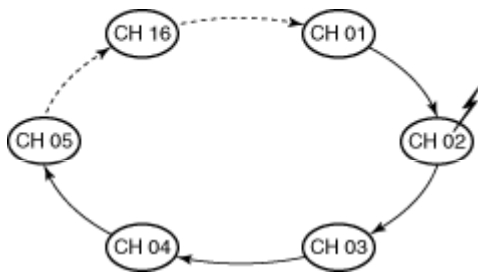

#### Priority Scan:

Priority scan. "Primary CH" and "Secondary CH" are used as the priority channel. The selected channels are scanned in sequence while monitoring "Primary CH" and "Secondary CH." When scan is paused on "Primary CH," other channels are not monitored.

#### When "Secondary CH" is not set:

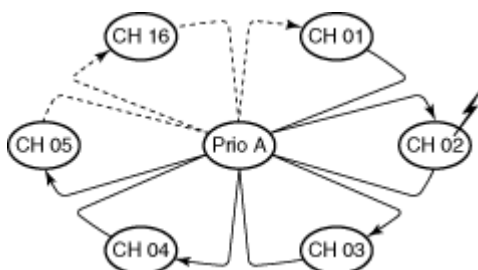

When a signal is detected on a channel other than "Primary CH," scan pauses until the signal disappears and "Primary CH" is continuously monitored. Scan moves and pauses on "Primary CH," if the signal is detected on.

#### When "Secondary CH" is set:

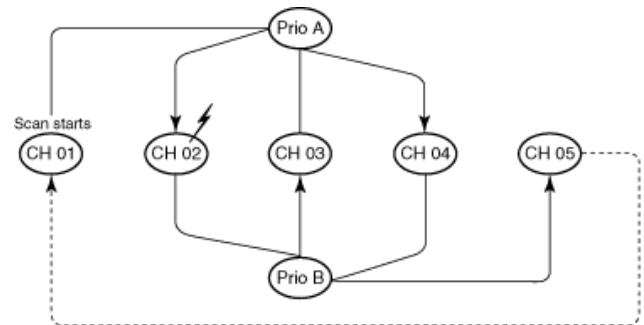

- When a signal is detected on a channel other than "Primary CH" or "Secondary CH," scan pauses until the signal disappears and "Primary CH" and "Secondary CH" are continuously monitored alternately. Scan moves and pauses on "Primary CH" or "Secondary CH" if the signal is detected on it.
- When a signal is detected on "Secondary CH," scan pauses until the signal disappears and "Primary CH" is continuously monitored. Scan moves and pauses on "Primary CH" if the signal is detected on it.

\* "Prio A" means "Primary CH," and "Prio B" means "Secondary CH."

**NOTE:** The scanning channels are selected in **Scan List** in the Memory CH screen.

#### The compatibility of the previous and current scan mode

The previous scan mode	The current scan mode						
	Scan Type	Primary CH	Secondary CH	TX CH	Talk Back	TX action	Cancel CH
Scan OFF	Scan OFF	-	-	-	-	-	-
Mode1 Normal	Normal	-	-	Last CH	-	Cancel	TX CH
Mode1 R.SelA	Normal	-	-	Start CH	ON	Pause	Start CH
Mode2 Prio-A	Priority	Prio-A	-	Prio-A	ON	Cancel	TX CH/TB
Mode2 Prio-A,B	Priority	Prio-A	Prio-B	Prio-A	ON	Cancel	TX CH/TB
Mode2 R.SelA	Priority	Start CH	-	Start CH	ON	Cancel	TX CH/TB
Mode2 R.SelA	Priority	Start CH	-	Start CH	ON	Pause	Start CH
Mode3 Prio-A	Priority	Prio-A	-	Prio-A	OFF	Cancel	TX CH
Mode3 Prio-A,B	Priority	Prio-A	Prio-B	Prio-A	OFF	Cancel	TX CH
Mode3 R.SelA	Priority	Start CH	-	Start CH	OFF	Cancel	TX CH
Mode3 R.SelA	Priority	Start CH	-	Start CH	OFF	Pause	Start CH

#### ➤ Primary CH (Available when "Priority Scan" is selected in Scan Type.)

Select the desired channel as a primary channel. The selected channel is monitored during priority scan.

<b>Prio-A CH</b>	The priority A channel is used as the primary channel.
<b>Prio-B CH</b>	The priority B channel is used as the primary channel.
<b>Start CH</b>	Scan start channel is used as the primary channel.
<b>CH Number Select</b>	The selected channel is used as the primary channel.

- **Secondary CH** (Available when "Priority Scan" is selected in **Scan Type**.)  
Select the desired channel as a secondary channel. The selected channel is monitored during priority scan. The secondary channel is lower priority than the primary channel.

<b>Disable</b>	The secondary channel is not used.
<b>Prio-A CH</b>	The priority A channel is used as the secondary channel.
<b>Prio-B CH</b>	The priority B channel is used as the secondary channel.
<b>Start CH</b>	Scan start channel is used as the secondary channel.
<b>CH Number Select</b>	The selected channel is used as the secondary channel.

- **TX CH** (Available when "Normal Scan" or "Priority Scan" is selected in **Scan Type**.)  
Select the desired channel as a transmission channel.

<b>Last CH</b>	Transmission is performed in the last busy channel. If there is no busy channel, the scan start channel is selected for transmission.
<b>Prio-A CH</b>	Transmission is performed on the priority A channel.
<b>Prio-B CH</b>	Transmission is performed on the priority B channel.
<b>Start CH</b>	Transmission is performed on the scan start channel.
<b>CH Number Select</b>	Transmission is performed on the selected channel.

- **Talk Back** (Available when "Normal Scan" or "Priority Scan" is selected in **Scan Type**.)  
Select the talk back function ON or OFF.  
If "Last CH" is selected in **TX CH**, this function is not available.

<b>ON</b>	When transmission is performed within the talk back timer time* (after the resume timer has passed), the signal is transmitted on the last busy channel.
<b>OFF</b>	Even if transmission is performed within the talk back timer time* (after the resume timer has passed), the signal is transmitted on the channel that is selected in TX CH.

- Talk back timer is set in **Talk Back (Sec)** in the Scan Setting screen.

- **TX Action** (Available when "Normal Scan" or "Priority Scan" is selected in **Scan Type**.)  
Select the scan condition when transmission is performed during scanning.

<b>Cancel Scan</b>	Scan is canceled and transmission is performed on the channel that is selected in TX CH. If Talk Back is turned ON and transmission is performed within the talk back timer time, the signal is transmitted on the last busy channel.
<b>Pause Scan</b>	Scan is paused until the signal disappears and then resumes after the resume timer time* has passed.

- \* Resume timer is set in **Resume (Sec)** in Scan Setting screen.

- **Cancel CH** (Available when "Normal Scan" or "Priority Scan" is selected in **Scan Type**.)  
Select the desired channel type that is selected when scan is cancelled (except for transmission.)

<b>Start CH</b>	The scan start channel is selected automatically.
<b>Start CH/Talk Back</b>	The scan start channel is selected automatically when scan is canceled during scanning. The last busy channel is selected automatically when scan is canceled while receiving a signal, or during scanning within the talk back timer time (after the resume timer has passed).
<b>TX CH</b>	The channel that is selected in TX CH is selected automatically.
<b>TX CH/Talk Back</b>	The channel that is selected in TX CH is selected automatically when scan is canceled during scanning. The last busy channel is selected automatically when scan is canceled while receiving a signal, or during scanning within the talk back timer time (after the resume timer has passed).

- **Text**  
Select the text indication capability from OFF, Text or Start CH during scan.

<b>OFF</b>	The text indication is turned OFF.
<b>Text</b>	The text indication is turned ON. The channel's text that is programmed in <b>Display Text</b> as above is indicated during scan.
<b>Start CH</b>	The text indication is turned ON. The scan start channel's text is indicated during scan.

## Voice scrambling function

The optional voice scrambler unit provides high performance private communication between stations with the same scrambler code. The 32 code non-rolling-type voice scrambler UT-109R and 1020 code rolling type UT-110R are available.

### ➤ Variable Split and Frequency Inversion

This is the scrambling system employed in the UT-109R and UT-110R. The audio frequency band is divided at a specified frequency (dividing frequency) and high and low audio frequencies in each band are inverted. The divided frequency is programmable with cloning.

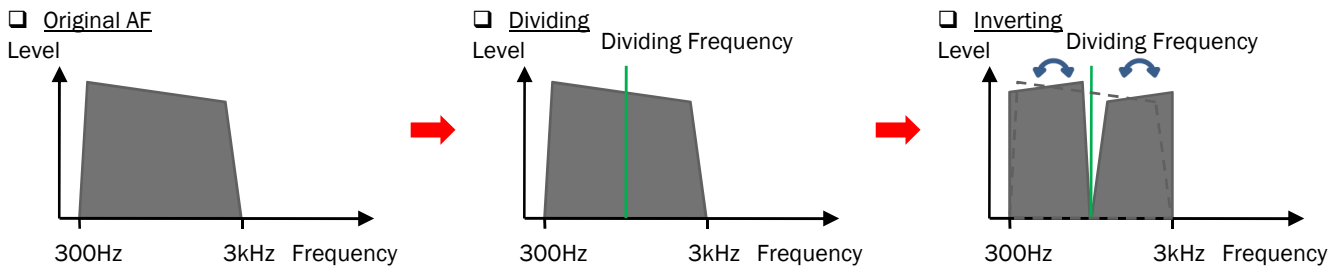

### ➤ Difference between rolling and non-rolling types

The rolling type (in fact, hopping type is used for the UT-110R) is an additional feature which provides higher communication security. It changes the divided frequency over a specified period.

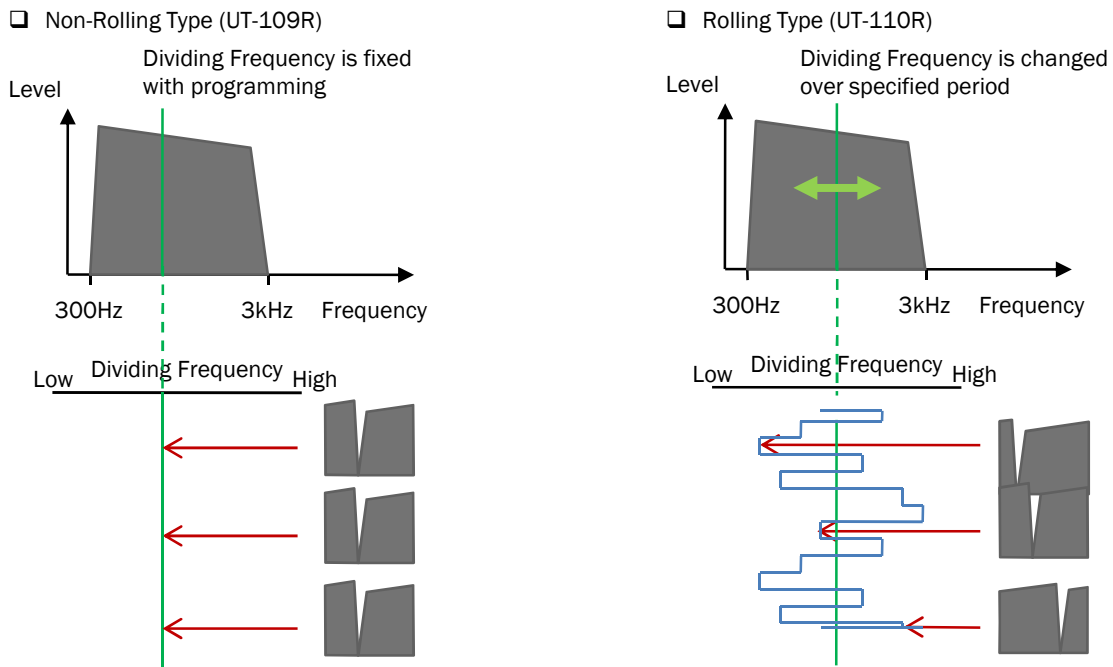

### ➤ Digital Voice Encryption Function

The IDAS system provides a 15-bit key (about 32,000 keys) encryption for secure communication.

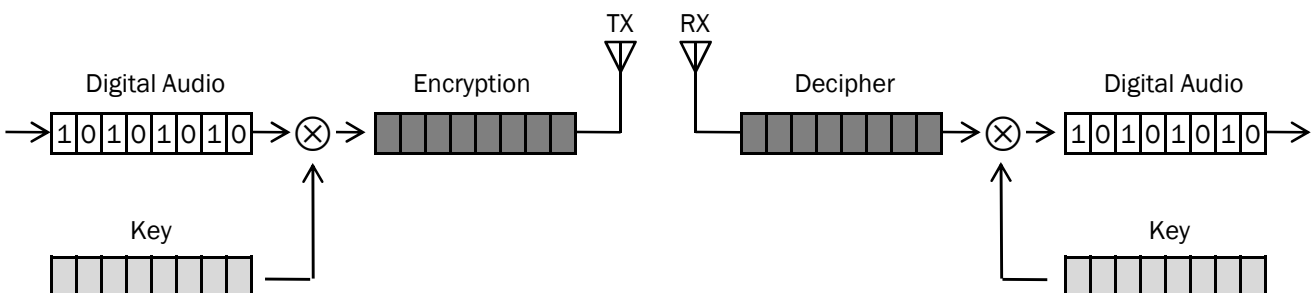

## ➤ Memory Channel - Scrambler/Encryption

This item is unavailable for the repeater operation.  
(Unavailable when **Repeat** or **Full-Duplex** is selected.)

### • ON/OFF

Turn the voice Scrambler/Encryption function ON or OFF as an initial setting.

<b>OFF</b>	Turn the voice Scrambler/Encryption function OFF.
<b>ON</b>	Turn the voice Scrambler/Encryption function ON.
<b>Inh</b>	The voice Scrambler/Encryption function selection for user is inhibited.

#### NOTE:

- The Scrambler/Encryption function can be manually toggled by [Scrambler/Encryption] key if this function is assigned to a key at Key & Display Assign screen.

### • Type (Unavailable when "Digital" is selected in CH Type.)

Select the desired voice scrambler type from UT- (UT-109/110), Inv (Inversion) or Oth (Other-T).

<b>UT-</b>	The optional UT-109R/UT-110R VOICE SCRAMBLER UNIT.
<b>Inv</b>	Internal voice scrambler is set to Inversion.
<b>Oth</b>	Other voice scrambler unit.

### • Code (Available when "UT-" or "Oth" is selected in Type.)

Program scrambler codes.

Available codes;

<b>Non-rolling type (UT-109R)</b>	1 to 32
<b>Rolling type (UT-110R)</b>	1 to 255

\*Set the voice scrambler type as Rolling or Non-rolling in the Common screen.

<b>Inv</b>	The code setting will be invalid.
<b>Oth</b>	1 to 16

#### NOTE:

- The optional UT-110R or UT-109R VOICE SCRAMBLER UNIT is required.  
- Set the **Scrambler-Group code** in the Common screen in advance.

### • Encryption Key List No. (Unavailable when "Analog" is selected in CH Type.)

Select the desired Encryption Key List No. within 1 to 63 for Digital mode operation.

The **Encryption Key (Hex)** settings in the Encryption screen must be specified to use the function.

## ➤ Common - Scrambler

### • Type

Set the installed voice scrambler type as Rolling or Non-rolling.

As Rolling type and Non-rolling type have different code settings, they are not compatible.

By selecting Non-rolling type in this item, you can use the UT-109R, or UT-110R as Non-rolling type.

Selectable value: Rolling or Non-rolling

#### NOTE:

1. This item is invalid for frequency inversion type.
2. When "Non-rolling type" is selected, the following Scrambler setting will be invalid.

### • Group Code

Set the Scrambler Group code number.

Available number: 1 to 4

### • Synchronous Capture

"Synchronous capture mode" is useful when communicating through a repeater.

However, because of voice components, the repeater cannot maintain synchronous mode in rare cases. Normally it is best to set this item to "Standard".

Selectable value: Standard (normal operation) or Continuous (repeater operation)

### • Tone Start Timing

Tone start timing selects the synchronous tone signal transmission delay time.

Set the delay time when the other party's repeater has power save mode.

Selectable value: OFF (default), 300 ms, 600 ms and 1100 ms.



### Digital - Analog Mixed mode connection

- Primarily operate in Analog mode
- Analog TX signal can be RX by Analog/Digital radios
- Digital TX signal can be RX by Digital radios
- One repeater operates in Digital mode and other repeater operates in Analog mode
- Analog radio operates in Analog mode
- Digital radio operates in Digital mode when communicating with other Digital radios
- Digital radio operates in Analog mode when communicating with Analog radios

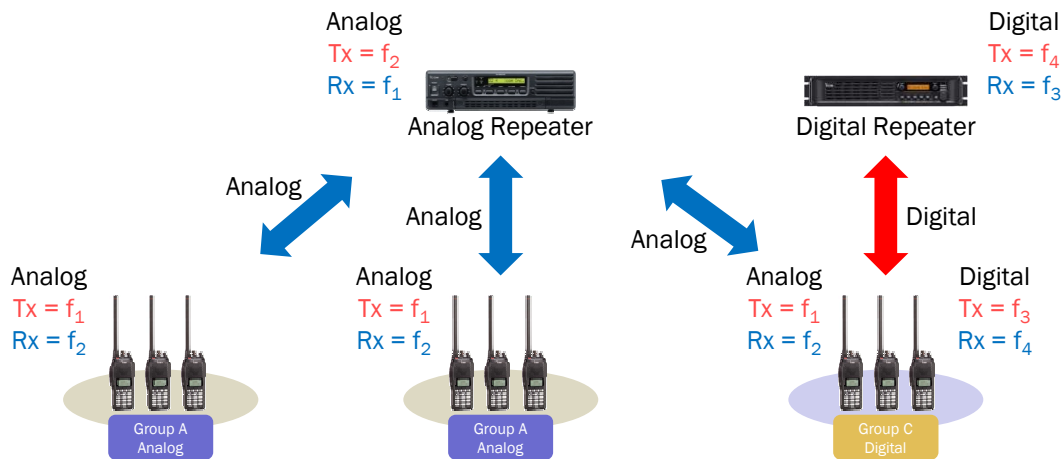

### Frequency

- $f_1$ : Analog Uplink (both Digital & Analog radios)
- $f_2$ : Analog Downlink
- $f_3$ : Digital Uplink
- $f_4$ : Digital Downlink

This is an example of Digital and Analog mixed mode operation when introducing digital system components into an existing analog system. This system primarily operates in Analog mode while utilizing the digital features that communicate between the digital radios.

### System requirement (One site)

Descriptions	Model Number	Quantity
UHF FM Repeater	IC-FR4000	
UHF Digital Repeater	IC-FR6000	
TX Antenna		
RX Antenna		

### Cloning Software Setup

- Set the Talk Back ON in the scan list setting for the transceivers in Group C to transmit an analog signal when received from Groups A and B

List	Scan Type	Primary CH	Secondary CH	TX CH	Talk Back
1	Normal	----	----	Last	----
2	Normal	----	----	Start	ON
3	Priority	Prio-A	----	Prio-A	ON
4	Priority	Prio-A	Prio-B	Prio-A	ON
5	Priority	Start	----	Start	ON
6	Priority	Start	----	Start	ON

- Set the same Scan List for Analog and Digital CH
- Set the CH Type Analog for Analog CH and CH Type Digital for Digital CH

CH	Scan List	Inc	Assign	Sel Inh	Auto Scan	CH Type
1	123	Inc	----	---		Analog
1-2	123	Inc	----	---		Digital

## Migration path

1. Introduce a digital system into a current network step by step
2. Operate in analog and digital modes in the different frequencies
3. Within the digital group communicate in digital mode
4. Communicate between a digital group and the analog group in analog mode

### Original Network – Analog only operation

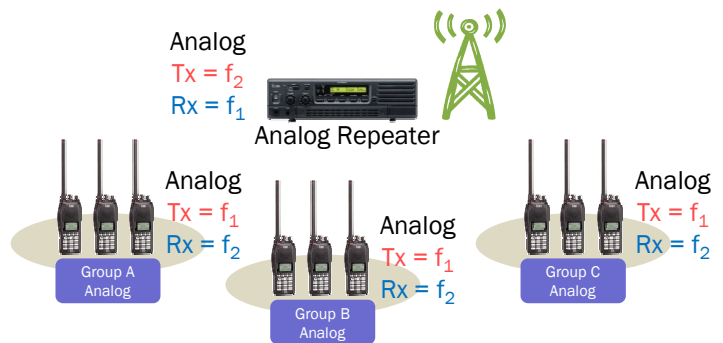

### Phase 1: Introduce a digital system into Group C

- Partially introduce a digital system into an existing analog network
- Replace the transceivers from analog to digital in Group C
- Add a digital repeater
- Allocate new frequencies to the digital network
- Set the Talk Back ON in the scan list setting for the transceivers in Group C to transmit an analog signal when received from Groups A and B

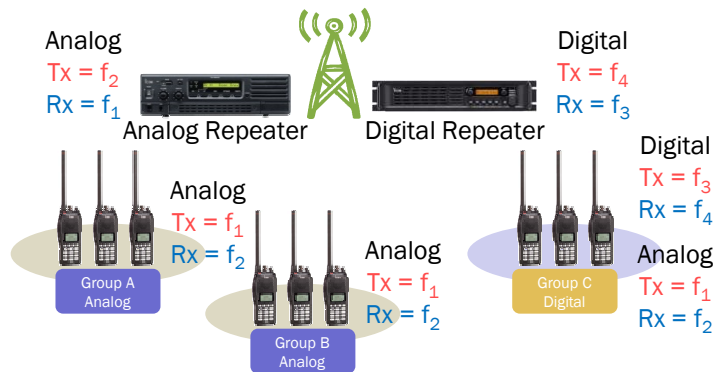

### Phase 2: Introduce a digital system into Group B

- Expand the digital system into a mixed operating network
- Replace the transceivers from analog to digital in Group B
- Set the Talk Back ON in the scan list setting for the transceivers in Group B to transmit an analog signal when received from Group A

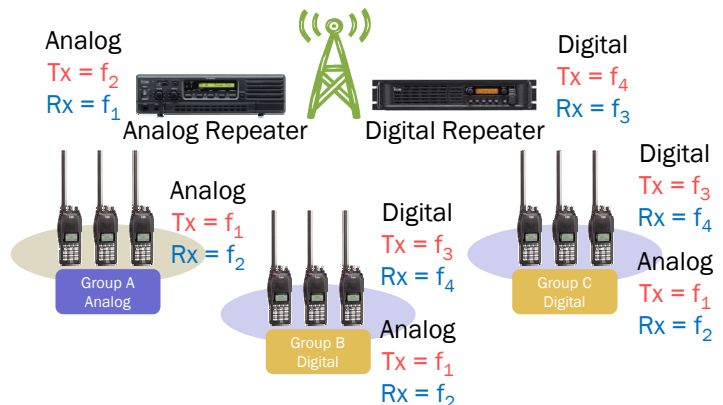

### Phase 3 Introduce a digital system into the Group A

- Convert to a full digital network from a mixed operating network
- Replace the transceivers from analog to digital in Group A
- Cancel Analog operation

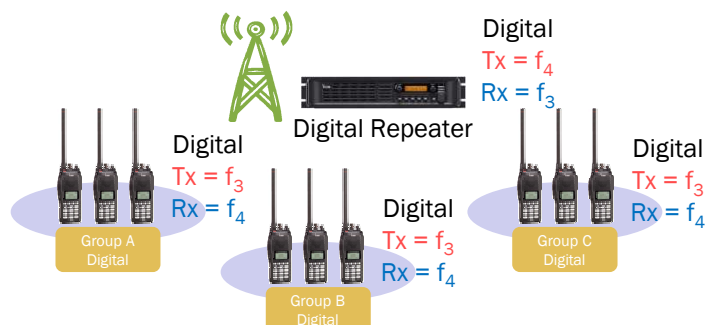

### Digital - Analog / Analog - Analog Cross mode connection

- Analog TX signal can be RX by Analog/Digital radios
- Digital TX signal can be RX by Analog/Digital radios
- Repeater/Digital radio operate in Mixed-Digital mode
- Analog radio operates in Analog mode
- Analog repeater for Analog TX only

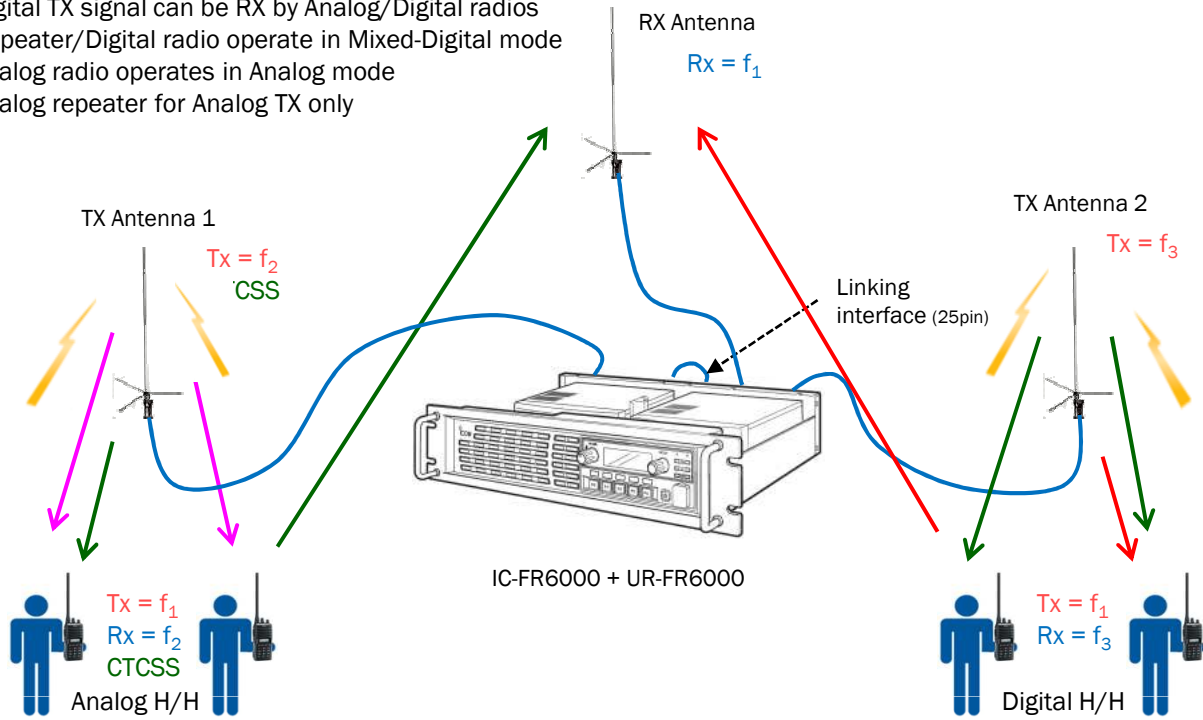

- Analog modulated signal from analog area
- Digital modulated signal from digital area
- Analog modulated signal from digital area

### Frequency

- $f_1$ : Uplink (both Digital & Analog)
- $f_2$ : Analog Downlink
- $f_3$ : Digital or Analog Downlink

This is an example of Digital and Analog cross mode operation. The IDAS radio (including repeater) can receive both analog mode and digital mode signals on a single channel. This function is useful when introducing digital system components into an existing analog system. It allows the system operator to communicate with analog only terminals while utilizing the digital features as required.

### System requirement (One site)

Descriptions	Model Number	Quantity
UHF Repeater	IC-FR6000	
UHF RF Module	UR-FR6000	
TX Antenna		
RX Antenna		
Multi Coupler		
Interface Cable	25p to 25p	

### Connection example

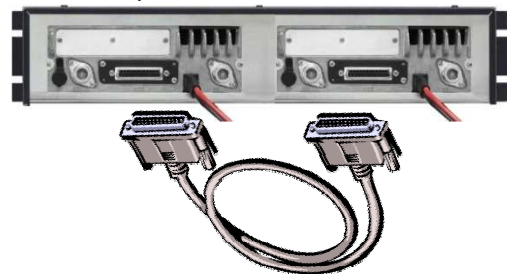

Connect two repeaters by interface cable (25p to 25p).

These interface cables are not sold as Icom accessories, therefore please assemble the interface cable by yourself. The connection diagram is as follows;

Analog Repeater (25pin)			Digital Repeater (25pin)	
Pin Description	Pin No.		Pin No.	Pin Description
MODIN	8	↔	22	AFOUT
EPTT	19	↔	21	Digital Audible
EPTT	19	↔	23	Analog Audible
GND	7,14	↔	7,14	GND

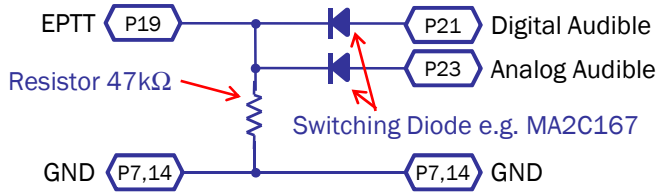



## ➤ Repeater Setting

### 1. Frequency and operation mode setting

#### Analog Repeater

RX = f0 TX = f2

Memory CH							
				Frequency (MHz)			
CH	Atr	Inh	Operation Mode	RX	TX	TX Inh	Text
1- 1	AB		Simplex	463.300000	<-		CHANNEL 1

Operation Mode = Simplex

#### Digital Repeater

RX = f1 TX = f3

Memory CH							
				Frequency (MHz)			
CH	Atr	Inh	Operation Mode	RX	TX	TX Inh	Text
1- 1	AB		Repeat	463.675000	463.675000		CHANNEL 4

Operation Mode = Repeat

### 2. CH Type and CTCSS/DTCS setting

#### Analog Repeater

CH Type = Analog

Memory CH						
			CW ID		FM	
CH	CH Type	Auto Reset	ON/OFF	Offset	Multi Table No.	TX C.Tone
1- 1	Analog	Tim-B		---	1	74.4

Necessary to setup when using CTCSS/DTCS.

#### Digital Repeater

CH Type = Mixed-Digital

Memory CH						
			CW ID		FM	
CH	CH Type	Auto Reset	ON/OFF	Offset	Multi Table No.	TX C.Tone
1- 1	Mixed-Digit	Tim-B		---		---

### 3. AF Min Level setting

Set Mode		
	Value	Enable/Inhibit
Backlight	Auto	Enable
LCD Contrast	50	Enable
Fan	Auto	Enable
Beep	OFF	Enable
SQL Level	9	Enable
AF Min Level	1	Enable
Mic Gain	3	Enable
Signal Moni	ON	Enable
LCD Check	----	Inhibit
Information	----	Inhibit
Key Check	----	Inhibit

← AF Min Level = 0 is inhibit Audible output mode therefore set AF Min Level = 1

### 4. External I/O Port Setting

Port Setting			
D-Sub 25pin			
Port	In/Out	Function	Active Logic
Ext.I/O 15	Input	Null	Low
Ext.I/O 16	Output	PO Monitor	Low
Ext.I/O 17	Output	Busy	Low
Ext.I/O 18	Input	Repeat Disable	Low
Ext.I/O 19	Input	EPTT	High
Ext.I/O 21	Output	Analog Audible	High
Ext.I/O 23	Output	Digital Audible	High
Ext.I/O 24	Output	Null	Low
Ext.I/O 25	Output	Hanger	Low
Ext.D/A 10	Output	RSSI	

#### 5-1. CTCSS setting

When using CTCSS of the Analog repeater.

#### Analog Repeater

Memory CH				Multiple Table			
				Table No. 1			
				FM			
CH	Multi Table No.	TX C.Tone	W/N	No.	Type	Decode	Encode
1- 1	1	79.7	W	1	Analog	79.7	<-
				2	Digital	25	<-
1- 2	1	---	W	3	Analog		
				4	Analog		

**Note:** Digital Repeater setup is not required.

**Note:** In order to add CTCSS to the modulation input from the D-SUB 25pin, TX C.Tone setting is necessary on top of the Multiple table setting.

#### 5-2. RAN setting

When using RAN of the Digital repeater

**Note:** Analog Repeater setup is not required

#### Digital Repeater

Multiple Table			
Table No. 1			
No.	Type	Decode	Encode
1	Analog	79.7	<-
2	Digital	25	<-
3	Analog		
4	Analog		

Memory CH				
Digital				
CH	TX RAN	Unit ID	Talkgroup ID List No.	Squelch Type
1- 1	---	---	---	---
1- 2	25	500	1	RAN

## ➤ Transceiver Setting

### 1. Frequency Setting

Analog Transceiver

RX = f2  
TX = f1

Digital Transceiver

RX = f3  
TX = f1

Zone 1: (Left CH - 496)

CH	Frequency (MHz)		TX W/N	SQL Tight	C.Tone		Text
	RX	TX			RX	TX	
1- 1	463.300000	453.675000	W		79.7	<-	ANALOG(FM)
1- 2	463.675000	453.675000	W				DIGITAL

Necessary to setup when using CTCSS.

### 2. CH Type setting

CH Type = Analog

CH Type = Mixed-Digi

Zone 1: (Left CH - 496)

CH	CH Type	Auto Reset	CH Mute	TX	RX C.No	2Tone		Digital		Unit ID
						Log	RX RAN	TX RAN		
1- 1	Analog	Tim-B	OR				1	<-	1	
1- 2	Mixed-Digi	Tim-B	OR				25	<-	110	

Necessary to setup when using RAN

# 5-3 Repeater Linking System

## 5-3-1 Repeater Linking System (1)



**Basic Repeater Linking System**

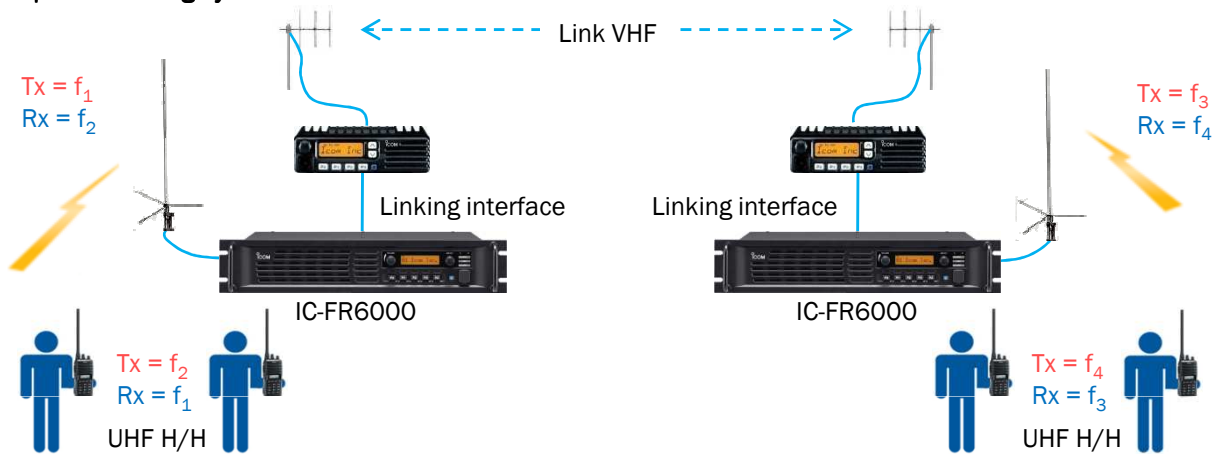

A repeater extends communications service area and it is very useful for two-way communications. Everyone thinks that the service area should be as wide as possible such as a cellular phone system. Now the service area can be extended with Icom repeaters!

This is a basic plan to upgrade the repeater site to a link system. This plan is suitable for linking two or more repeater sites. When a subscriber transmits, the repeater re-transmits a received signal. At the same time, the received signal is sent to another repeater site, through a VHF mobile radio. These VHF radios work as link radios between repeater sites.

**System requirements (One site)**

Descriptions	Model Number	Quantity
UHF Repeater	IC-FR6000	
UHF Antenna		
Duplexer		
VHF Mobile Radio	IC-F111	
VHF Antenna		
Power Supply		
Duplexer		
ACC Cable	OPC-617	
Interface Cable	25p to 9p	

**Connection example**

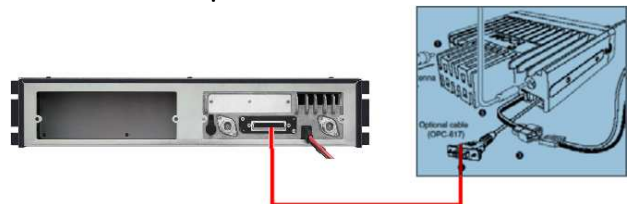

Connect two repeaters by interface cable (25p to 9p).

These interface cables are not sold as Icom accessories, therefore please assemble the interface cable by yourself. The connection diagram is as follows;

Repeater (25pin)			OPC-617 (9pin)	
Pin Description	Pin No.		Pin No.	Pin Description
BUSY OUT	17	↔	5	PPT CONT IN
MOD IN	8	↔	3	DET AF OUT
DISC OUT	9	↔	4	MOD IN
EPPT	19	↔	1	HORN DRIVE
GND	7,14	↔	8, 9	GND



### Basic Repeater Linking System

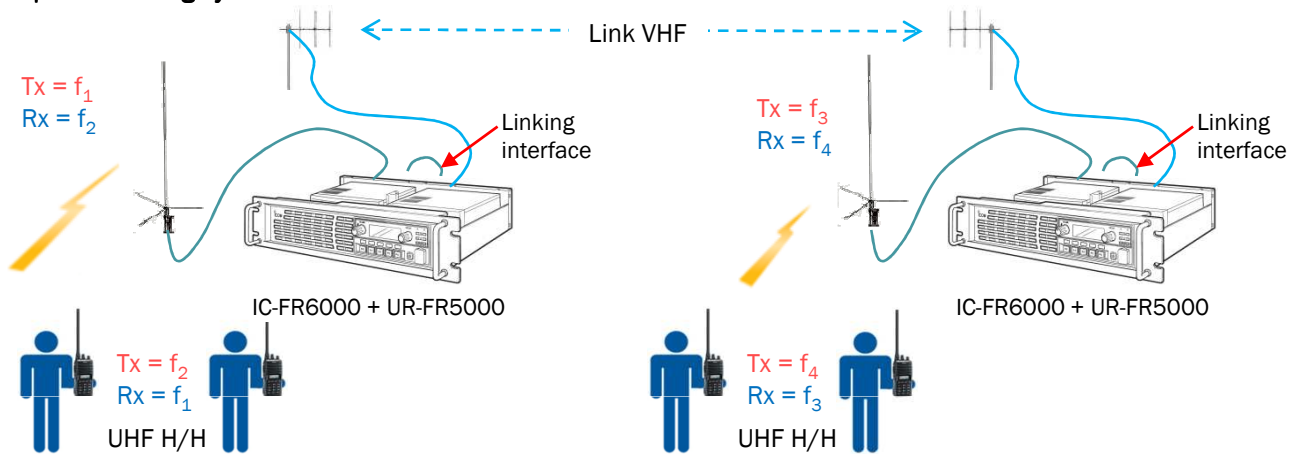

This is an advanced plan to upgrade the repeater site to a link system. An ICOM repeater also works as a base station (simplex), therefore this system is more versatile. Applicable for repeater link, cross-band repeater, etc..

### System requirement (One site)

Descriptions	Model Number	Quantity
UHF Repeater	IC-FR6000	
UHF Antenna		
Duplexer		
VHF RF Module	UR-FR5000	
VHF Antenna		
Duplexer		
Interface Cable	25p to 25p	

### Connection example

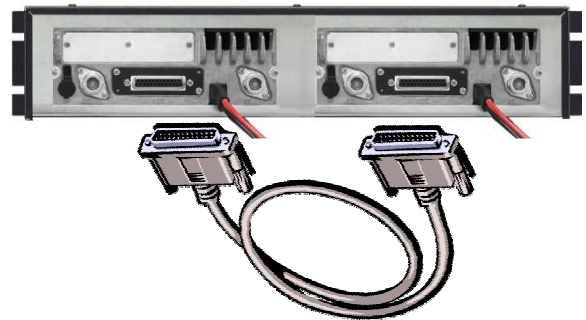

Connect two repeaters by interface cable (25p to 25p).

These interface cables are not sold as Icom accessories, therefore please assemble the interface cable by yourself. The connection diagram is as follows;

Repeater (25pin)			Repeater (25pin)	
Pin Description	Pin No.		Pin No.	Pin Description
BUSY OUT	17	↔	19	EPPT IN
MOD IN	8	↔	9	DISC OUT
DISC OUT	9	↔	8	MOD IN
EPPT	19	↔	17	BUSY OUT
GND	7,14	↔	7, 14	GND

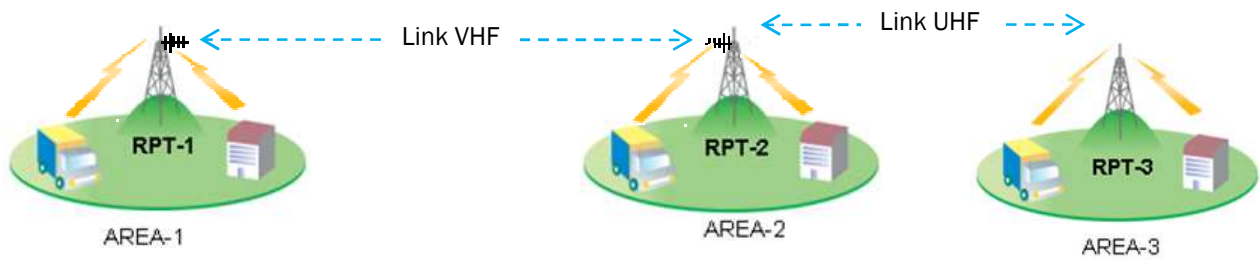

### Advanced Repeater Linking System

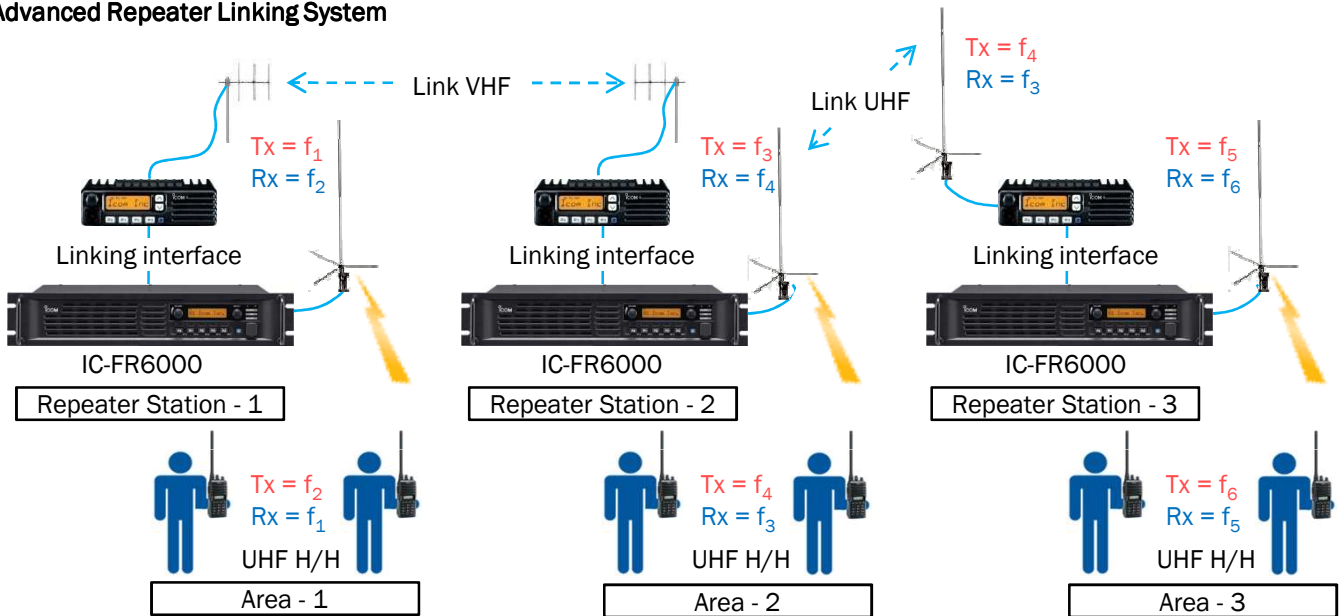

This is an advanced plan to upgrade the repeater site to a link system. This plan is suitable for linking three repeater sites. When a subscriber transmits, the repeater re-transmits a received signal. At the same time, the received signal is sent to another repeater site, through VHF mobile radios and UHF mobile radios. These VHF and UHF radios work as link radios between repeater sites.

Descriptions	Model Number	Quantity
UHF Repeater	IC-FR6000	
UHF Antenna		
Duplexer		
VHF Mobile Radio	IC-F111	
VHF Antenna		
UHF Mobile Radio	IC-F211	
UHF Antenna		
Power Supply		
Duplexer		
ACC Cable	OPC-617	
Interface Cable	25p to 9p	

### Connection example

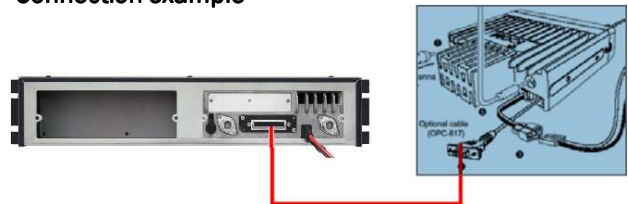

Connect two repeaters by interface cable (25p to 9p).

These interface cables are not sold as Icom accessories, therefore please assemble the interface cable by yourself. The connection diagram is as follows;

Repeater (25pin)			OPC-617 (9pin)	
Pin Description	Pin No.		Pin No.	Pin Description
BUSY OUT	17	↔	5	PPT CONT IN
MOD IN	8	↔	3	DET AF OUT
DISC OUT	9	↔	4	MOD IN
EPPT	19	↔	1	HORN DRIVE
GND	7,14	↔	8, 9	GND

### Basic Repeater to Phone Line Connecting System

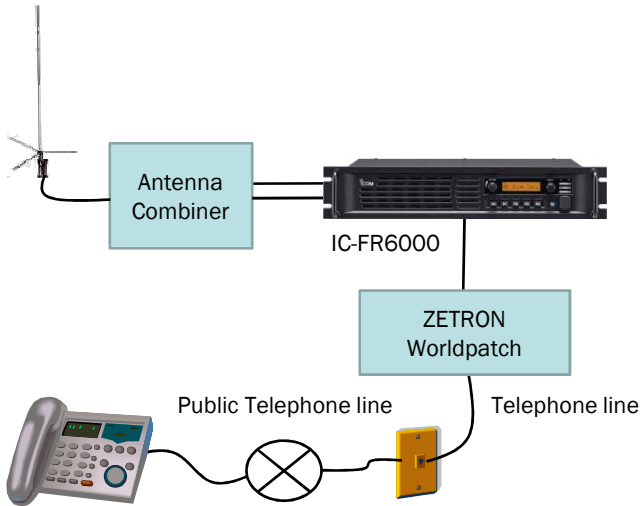

This is an example for a telephone connection added to a single repeater site. The IC-FR5000/6000 repeater can be connected to the telephone line via an external phone patch device. When a subscriber transmits DTMF dialing codes, the received signal is sent to the telephone line to connect the phone.

#### ➤ Repeater and Worldpatch connection

Repeater (25pin)			Worldpatch (10pin)	
Pin Description	Pin No.		Pin No.	Pin Description
+13.6V OUT	11	↔	1	+12V IN
DISC OUT	9	↔	3	DISC IN
MOD IN	8	↔	5	TX AUD
EPPT	19	↔	7	PTT OUT
Busy	15	↔	8	COR IN
GND	7,14	↔	2, 4, 6	GND

#### System requirements with Telephone connection (One site)

Descriptions	Model Number	Quantity
UHF Repeater	IC-FR6000	
UHF Antenna		
Antenna Combiner		
ZETRON Worldpatch		

### Tone Remote System

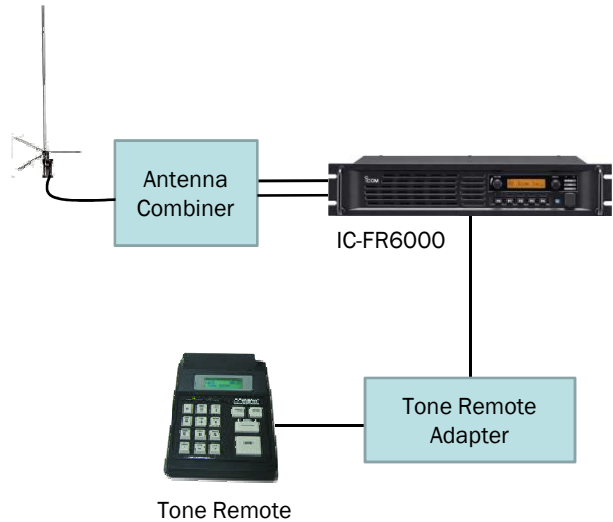

This is an example for a Tone Remote Controller added to a single repeater site.

#### ➤ Repeater and Tone Remote Adaptor connection

Repeater (25pin)			Tone Remote Adaptor	
Pin Description	Pin No.		Pin No.	Pin Description
+13.6V OUT	11	↔		+12V IN
AF OUT	22	↔		RX IN
MOD IN	8	↔		TX OUT
EPPT	19	↔		PTT OUT
Key Moni	17*	↔		MONITOR OUT
GND	7,14	↔		GND
MCH Select :1	15*	↔		F1
MCH Select :2	16*	↔		F2
MCH Select :3	23*	↔		F3
MCH Select :4	24*	↔		F4
MCH Select :5	25*	↔		F5

\* The desired functions can be assigned to EXT. I/O 15 to 25.

#### System requirements (One site)

Descriptions	Model Number	Quantity
Repeater	IC-FR6000	
Antenna		
Antenna Combiner		
Tone Remote Adaptor		
Tone Remote		

**Note:** The above connections are for your reference only. Ask your dealer for details.

\* All diagrams in this section show a 3 channel system example.

### Single Site Trunking System

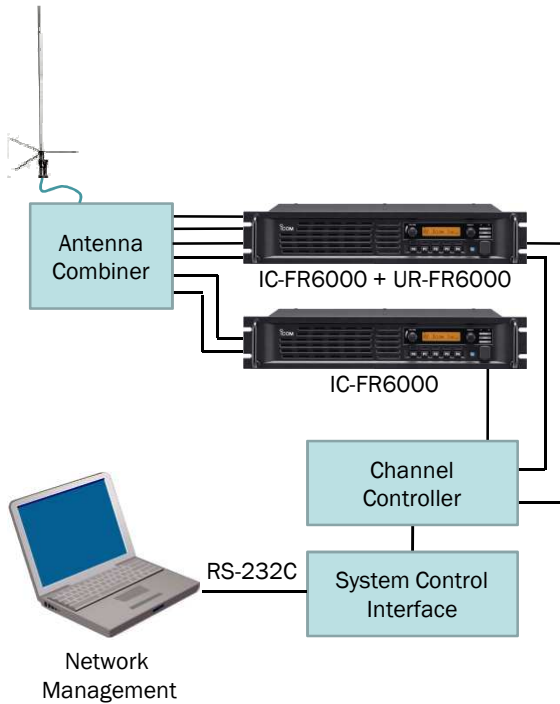

The IC-FR5000/IC-FR6000 series has D-SUB 25 pin/modular interfaces for external controllers such as PassPort™ and MPT1327. MPT1327 is a signalling standard for trunked private land mobile radio systems. It defines the protocol rules for communication between a trunking system controller (TSC) and users' radio units. This is a basic plan to upgrade the repeater site to a trunking system. This plan is an example of a single trunking repeater site.

#### System requirements (One site)

Descriptions	Model Number	Quantity
UHF Repeater	IC-FR6000	
Channel Module Unit	UR-FR6000	
UHF Antenna		
Antenna Combiner		
Channel Controller		
System Control IF		
PC		
Management Software		

### Single Site Trunking System with telephone line connection

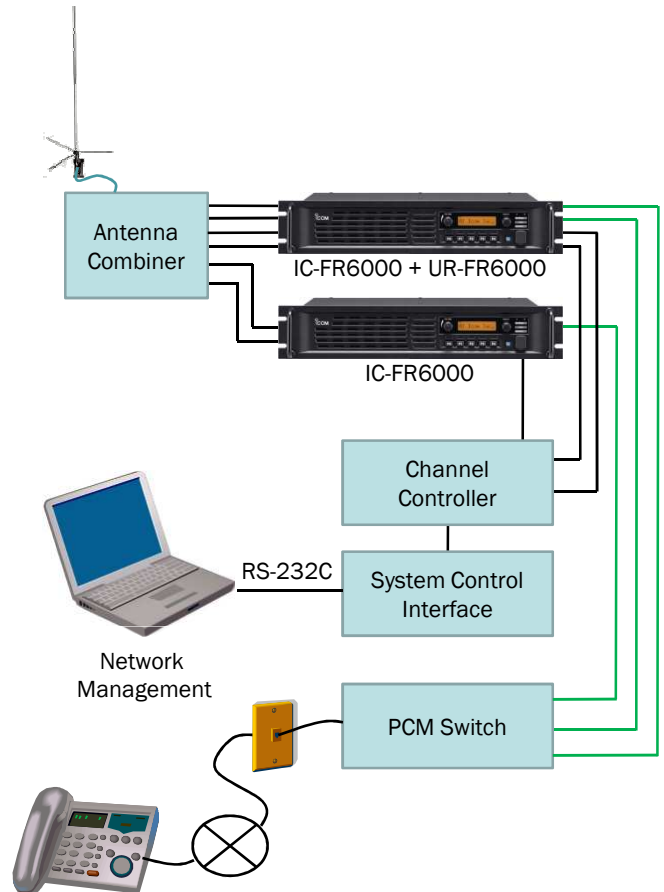

This is an example to upgrade to a telephone connection added to a single trunking repeater site.

#### System requirements with Telephone connection (One site)

Descriptions	Model Number	Quantity
UHF Repeater	IC-FR6000	
Channel Module Unit	UR-FR6000	
UHF Antenna		
Antenna Combiner		
Channel Controller		
System Control IF		
PC		
Management Software		
PCM Switch		
PSTN or PABX		

Single Site Trunking System with telephone line connection

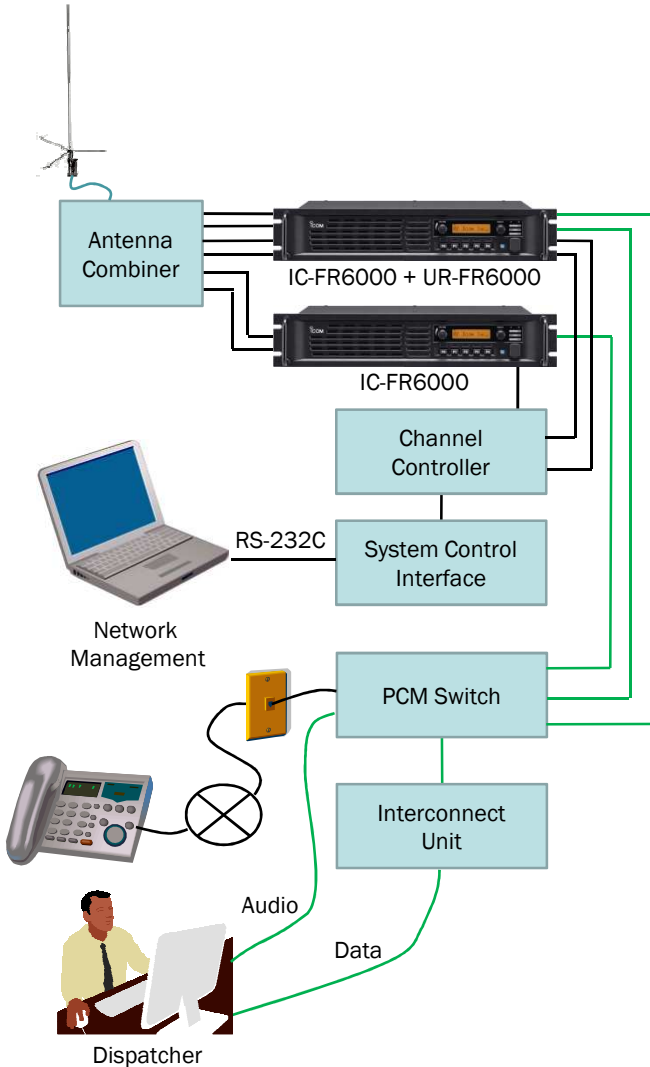

This is an example to upgrade to a telephone and data connection added to the single trunking repeater site.

**System requirements (One site)**

Descriptions	Model Number	Quantity
UHF Repeater	IC-FR6000	
Channel Module Unit	UR-FR6000	
UHF Antenna		
Antenna Combiner		
Channel Controller		
System Control IF		
PC		
Management Software		
PCM Switch		
Interconnect Unit		
PSTN or PABX		

Single Site Trunking System with telephone line connection and Vehicle and Personnel Tracking

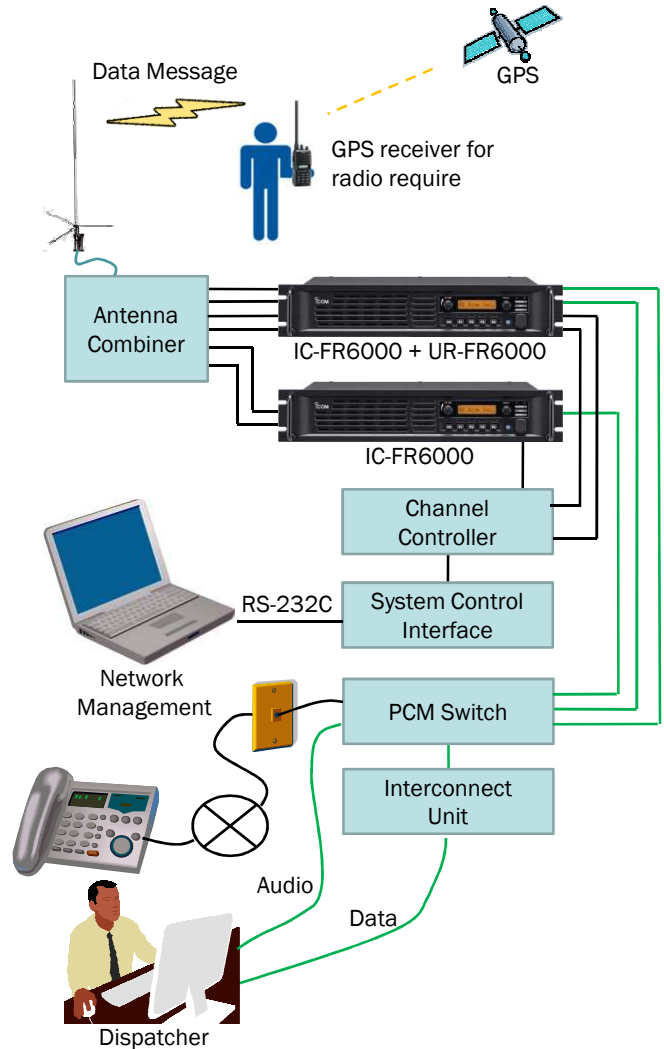

This is an example to upgrade to a telephone and data connection added to the single trunking repeater site. It also enables expansion to Vehicle and Personnel Tracking.

**System requirements (One site)**

Descriptions	Model Number	Quantity
UHF Repeater	IC-FR6000	
Channel Module Unit	UR-FR6000	
UHF Antenna		
Antenna Combiner		
Channel Controller		
System Control IF		
PC		
Management Software		
PCM Switch		
Interconnect Unit		
Mapping Software		
PSTN or PABX		



# MPT1327 Trunking System

## Regional Trunking System

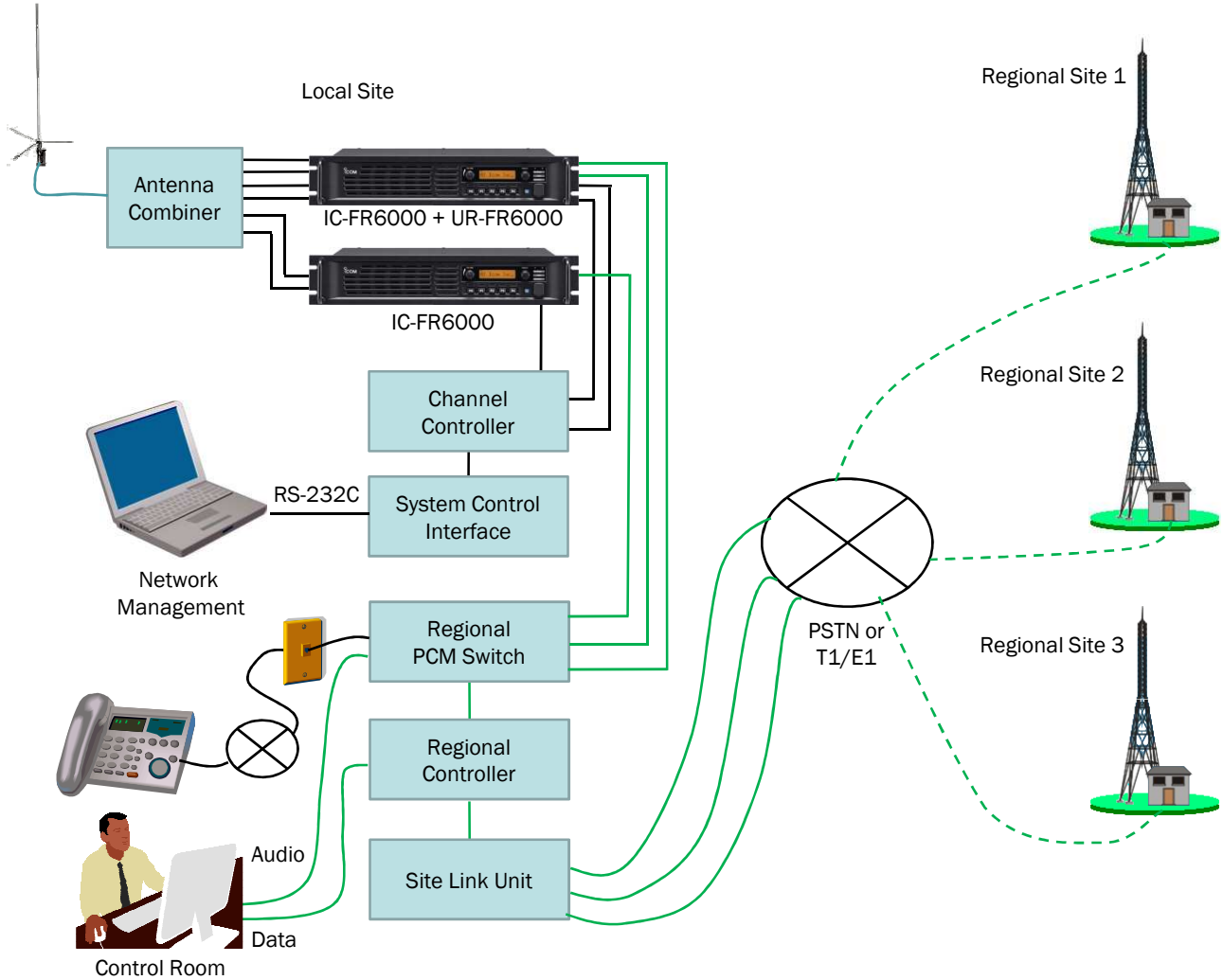

This is a plan to upgrade to a site linked regional trunking system.

### System requirement (One site)

Descriptions	Model Number	Quantity
UHF Repeater	IC-FR6000	
Channel Module Unit	UR-FR6000	
UHF Antenna		
Antenna Combiner		
Channel Controller		
System Control IF		
PC		
Management Software		
Regional PCM Switch		
Regional Controller		
PSTN/PABX or T1/E1		

# 5-6 LTR™ Trunking System

## 5-6-1 Single Site LTR™ Trunking System

\* All diagrams in this section show a 3 channel system example.

Single Site LTR™ Trunking System

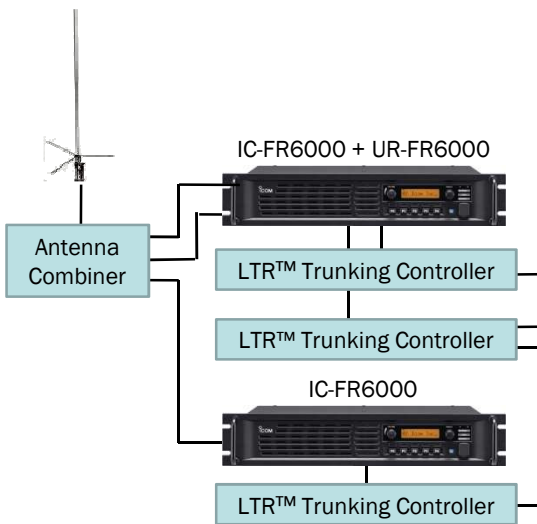

Single Site LTR™ Trunking System with Telephone Line Connection

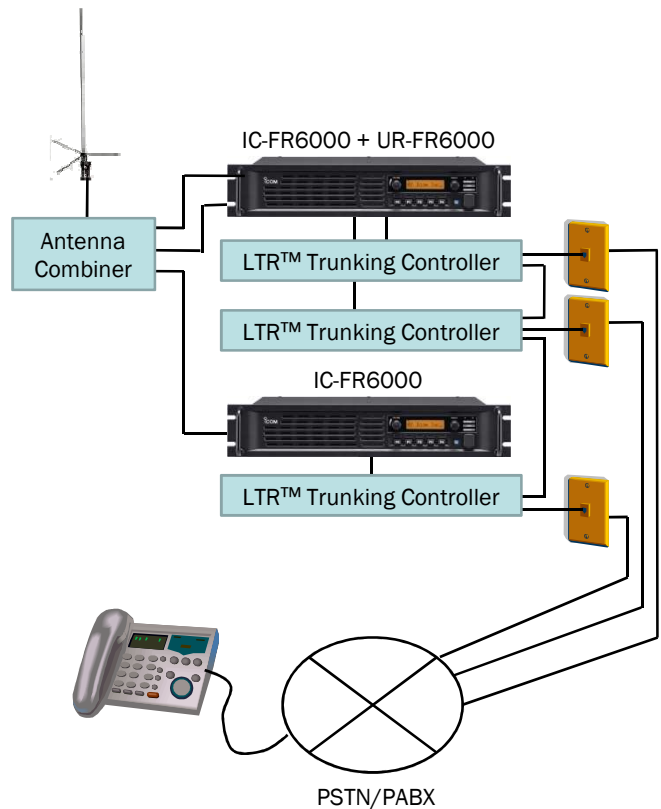

The IC-FR6000 series has D-SUB 25 pin/modular interfaces for external controllers such as LTR™, PassPort™ and MPT1327. LTR™ is a signalling standard for trunked private land mobile radio systems. It defines the protocol rules for communication between a trunking system controller and users' radio units. This plan is an example of single trunking repeater site .

This is an example to upgrade to a telephone connection added to the single trunking repeater site.

**System requirements (One site)**

Descriptions	Model Number	Quantity
UHF Repeater	IC-FR6000	
Channel Module Unit	UR-FR6000	
UHF Antenna		
Antenna Combiner		
Trunking Controller		

**System requirements (One site)**

Descriptions	Model Number	Quantity
UHF Repeater	IC-FR6000	
Channel Module Unit	UR-FR6000	
UHF Antenna		
Antenna Combiner		
Trunking Controller		
PSTN or PABX		

# 5-6-2 Digital Networked LTR™ or PassPort™ Trunking System

## Digital Networked LTR™ or PassPort™ Trunking System

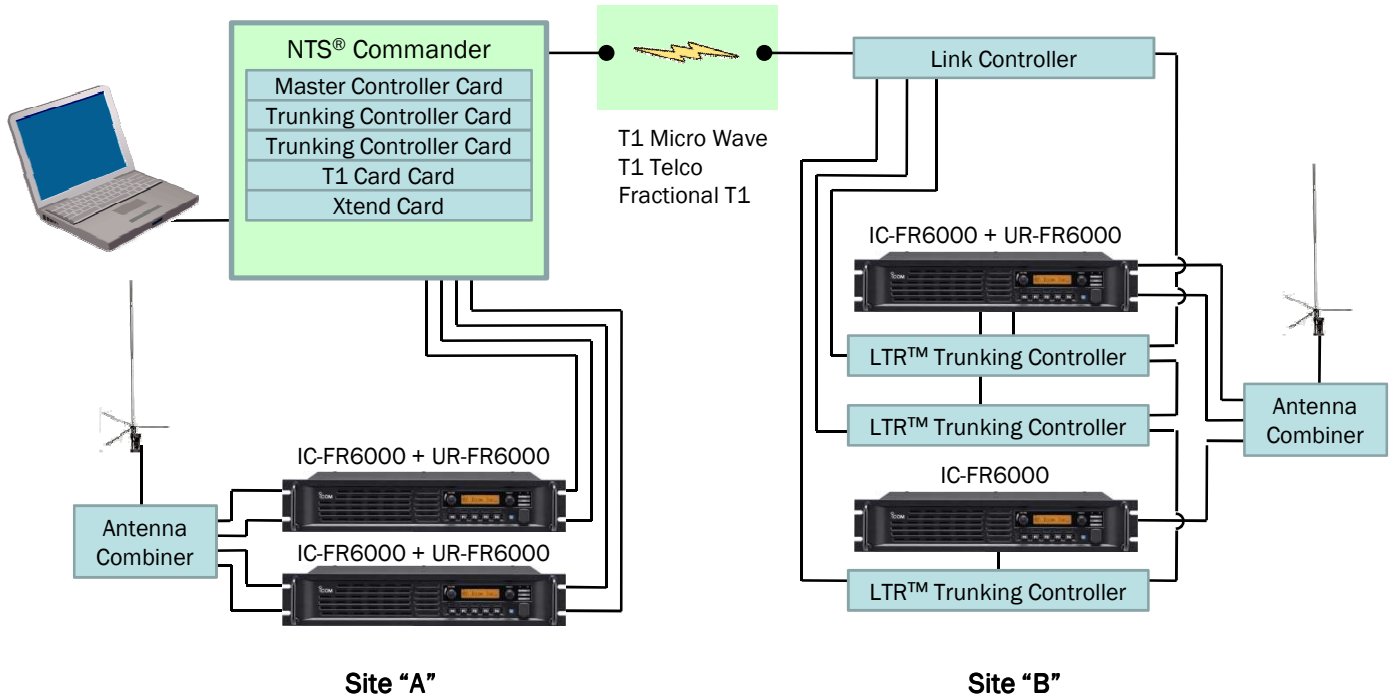

This is an example to upgrade to a digital network added to the single trunking repeater site.

### System requirements (Site "A")

Descriptions	Model Number	Quantity
UHF Repeater	IC-FR6000	
Channel Module Unit	UR-FR6000	
UHF Antenna		
Antenna Combiner		
NTS® Commander		
Master Controller Card		
Trunking Controller Card		
T1 Card Card		
Xtend Card		
PC		

### System requirements (Site "B")

Descriptions	Model Number	Quantity
UHF Repeater	IC-FR6000	
Channel Module Unit	UR-FR6000	
UHF Antenna		
Antenna Combiner		
Trunking Controller		
Link Controller		

# 5-6-3 Analog Networked LTR™ or PassPort™ Trunking System

## Analog Networked LTR™ or PassPort™ Trunking System

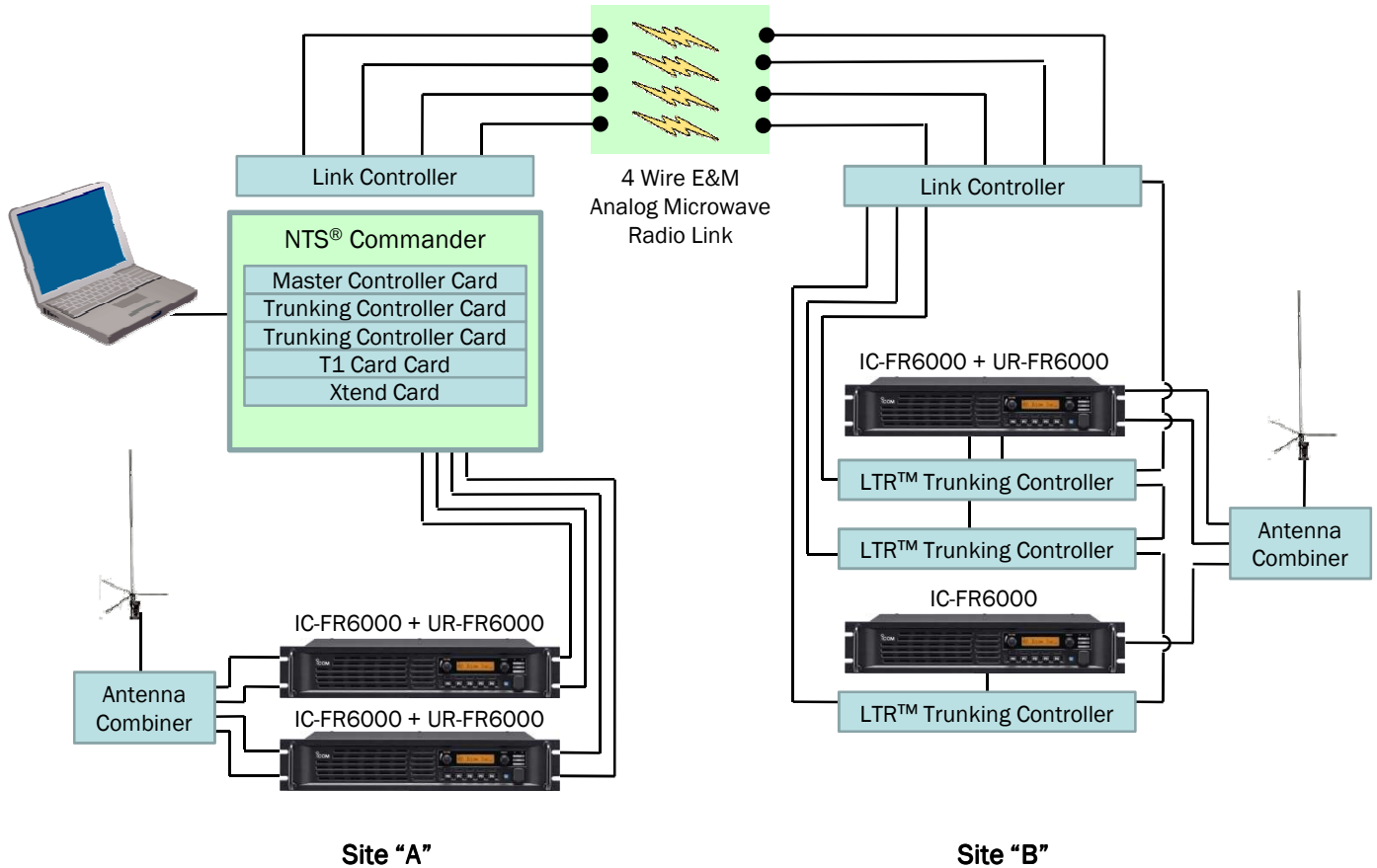

This is an example to upgrade for analog network added to the single trunking repeater site.

### System requirements (Site "A")

Descriptions	Model Number	Quantity
UHF Repeater	IC-FR6000	
Channel Module Unit	UR-FR6000	
UHF Antenna		
Antenna Combiner		
Link Controller		
NTS® Commander		
Master Controller Card		
Trunking Controller Card		
T1 Card Card		
Xtend Card		
PC		

### System requirements (Site "B")

Descriptions	Model Number	Quantity
UHF Repeater	IC-FR6000	
Channel Module Unit	UR-FR6000	
UHF Antenna		
Antenna Combiner		
Trunking Controller		
Link Controller		

## Solar power system

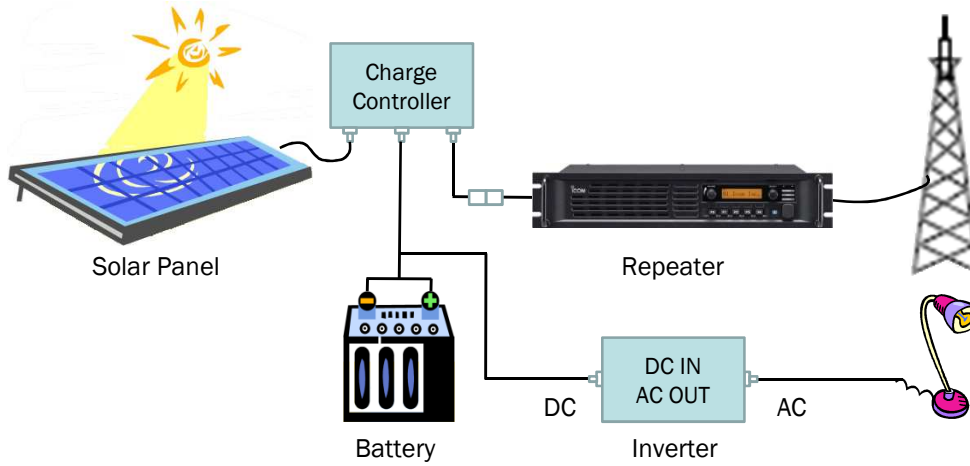

Descriptions	Model Number	Quantity
Solar Panel		
Charge Controller		
Battery		
Inverter		
Repeater		
Antenna		

### ➤ Solar power system

In order to design a solar power system you'll have to first determine your estimated electrical needs and available resources to generate electric power. Check there is enough sun light available at the location, to determine the type of generation system to make.

#### Check points

- Calculate Your Total Daily Amp Hour usage
- Calculate how many Solar Panels you will need
  - Total average amp hours per day
  - Average sun hours per day in your area
  - Continuous non-sunshine days in your area
- Calculate what size of Batteries you will need

➤ **Calculate Your Total Daily Amp Hour usage**

AC Loads				
List AC load items	Quantity	X	Watts	X Hrs/week = Wh/week
_____	_____		_____	_____
_____	_____		_____	_____
_____	_____		_____	_____
Total Wh/week				_____ - ①
DC watt hours per week. Multiply line ① by 1.15 to correct for inverter loss.				_____ - ②
Inverter DC input voltage; This is DC system voltage.				_____ 12 - ③
Divide line ② by line ③. This is total amp hours per week used by AC loads.				_____ - ④

DC Loads				
List DC load items	Quantity	X	Watts	X Hrs/week = Wh/week
_____	_____		_____	_____
_____	_____		_____	_____
_____	_____		_____	_____
Total Wh/week				_____ - ⑤
DC system voltage.				_____ 12 - ⑥
Total amp hours per week used by DC loads. Divide line ⑤ by line ⑥.				_____ - ⑦
Total amp hours per week used by AC loads from line ④				_____ - ⑧
Add lines ⑦ and ⑧. This is total amp hours per week used by all loads.				_____ - ⑨
Divide line ⑨ by 7 days. This is total average amp hours per day.				Daily Amp Hour Usage = <input style="width: 50px;" type="text"/> - ⑩

➤ **Calculate how many Solar Panels you will need**

Total average amp hours per day	_____ - ①
Divide line ① by 0.8 to compensate for loss from battery charge/discharge	_____ - ②
Average sun hours per day in your area	_____ - ③
Divide line ② by line ③. for total amps required	_____ - ④
Multiply line ④ by 1.15 to correct for generating loss.	_____ - ⑤
Continuous non-sunshine days in your area	_____ - ⑥
Multiply line ⑤ and line ⑥ for total solar array amps required.	_____ - ⑦
Peak amps of solar module used	_____ - ⑧
Total number of solar modules in parallel. Divide line ⑦ by ⑧.	_____ - ⑨
Round off to the next highest whole number.	Number of Solar Panels = <input style="width: 50px;" type="text"/> - ⑩

➤ **Calculate what size of Batteries you will need**

Total average amp hours per day	_____ - ①
Divide line ① by 0.8 to compensate for loss from battery charge/discharge	_____ - ②
Continuous non-sunshine days in your area	_____ - ③
Multiply line ② and line ③ for total Wh required.	_____ - ④
DC system voltage.	_____ 12 - ⑤
Divide line ④ by line ⑤ for required Ah.	_____ - ⑥
Safety factor	_____ 2 - ⑦
Multiply line ⑥ and line ⑦ for total battery capacity Ah required.	Battery Capacity = <input style="width: 50px;" type="text"/> - ⑧

# 5-8 Wind-Solar Hybrid Powered Repeater System

## Wind-Solar Hybrid power system

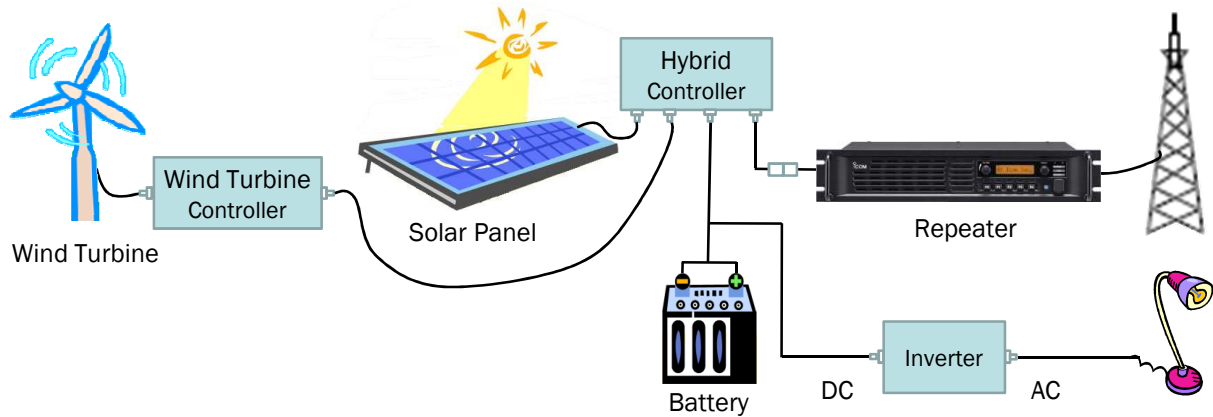

Descriptions	Model Number	Quantity
Wind Turbine		
Wind Turbine Controller		
Solar Panel		
Hybrid Controller		
Battery		
Inverter		
Repeater		
Antenna		

### ➤ Wind-Solar Hybrid power system

In order to design a wind-solar hybrid power system you'll have to first determine your estimated electrical needs and available resources to generate electric power. Check there are enough wind resources available at the location , and check there is enough sun light available at the location, to determine the type of generation system to make.

### Other considerations

- Wind speeds increase with height. In general, the higher the tower, the more power the wind system can produce.
- How many No wind days to cover
- How many No sun shine days to cover
- How to split duty between wind and solar power
- Wind And Solar Often Have Seasonally Complimentary Resources
  - Summer: Low Wind / High Solar
  - Winter: High Wind / Low Solar

Reference of Wind Turbine Power generation figure, model Z-500 from Zephyr

Wind blow hours		5 hours			8 hours			12 hours		
Mean wind Velocity m/s	Gen. output W	Daily mean velocity m/s	Gen. power Wh	Monthly gen. power kWh	Daily mean velocity m/s	Gen. power Wh	Monthly gen. power kWh	Daily mean velocity m/s	Gen. power Wh	Monthly gen. power kWh
4	15	0.8	75	2.3	1.3	120	3.7	2.0	180	5.5
8	120	1.7	600	18.3	2.7	960	29.2	4.0	1440	43.8
12.5	400	2.6	2000	60.8	4.2	3200	97.3	6.3	4800	146.0

# Wind-Solar Hybrid Powered Repeater System

## Wind turbine power

Wind is the “fuel” for your wind generator. The power in the wind can be transferred to electric power. The amount of transferred power is directly proportional to the density of the air, the area swept out by the rotor, and the cube of the wind speed.

$$P = \frac{1}{2} \alpha \rho \pi r^2 v^3$$

The power P available in the wind is given by:

- P = power in watts
- $\alpha$  = efficiency constant
- $\rho$  = mass density of air in kilograms per cubic meter
- r = radius of the wind turbine in meters
- v = velocity of the air in meters per second

## Efficiency

Depends on make and model of wind turbine which you choose.

## Density

The higher a wind generator is from sea level, the lower the air density. Air density is directly proportional to the output of your turbine.

The figure below should be used in your calculation depending on the height from sea level of your installation site.

0 – 150 m	1 - 500 ft	100%
150 – 300 m	500 - 1000 ft	97%
300 – 600 m	1000 - 2000 ft	94%
600 – 900 m	2000 - 3000 ft	91%
900 – 1200 m	3000 - 4000 ft	88%
1200 – 1500 m	4000 - 5000 ft	85%
1500 – 1800 m	5000 - 6000 ft	82%
1800 – 2100 m	6000 - 7000 ft	79%
2100 – 2400 m	7000 - 8000 ft	76%
2400 – 2700 m	8000 - 9000 ft	73%
2700 – 3000 m	9000 - 10000 ft	70%

## Radius

Depends on make and model of wind turbine which you choose.

## Velocity

Wind maps are available for many countries which will give you an idea of the wind resource at the site where you are planning to install. Check out these maps and see if you have sufficient wind resource.

## Power Cable

➤ Choose the right power cable for the system

You should choose the correct size (gauge) of cable depending on usage of power and cable distance as indicated below for your reference.

Recommended Cable Size by Power and Distance (DC12V system)

Total RMS Power (Watts)	Distance				
	3m 96.84ft	5m 16.40ft	10m 32.81ft	20m 65.62ft	30m 98.43ft
100W	5.3mm <sup>2</sup> 10 gauge	5.3mm <sup>2</sup> 10 gauge	8.4mm <sup>2</sup> 8 gauge	13.3mm <sup>2</sup> 6 gauge	21.2mm <sup>2</sup> 4 gauge
200W	5.3mm <sup>2</sup> 10 gauge	8.4mm <sup>2</sup> 8 gauge	13.3mm <sup>2</sup> 6 gauge	21.2mm <sup>2</sup> 4 gauge	33.6mm <sup>2</sup> 2 gauge
300W	8.4mm <sup>2</sup> 8 gauge	13.3mm <sup>2</sup> 6 gauge	21.2mm <sup>2</sup> 4 gauge	33.6mm <sup>2</sup> 2 gauge	53.5mm <sup>2</sup> 0 gauge
500W	13.3mm <sup>2</sup> 6 gauge	21.2mm <sup>2</sup> 4 gauge	33.6mm <sup>2</sup> 2 gauge	53.5mm <sup>2</sup> 0 gauge	67.4mm <sup>2</sup> 00 gauge

American Wire Gauge (AWG):

AWG gauge	Wire Size mm <sup>2</sup>	Ohms per 1000 ft	Ohms per km
0000	107.22	0.0490	0.1607
000	85.01	0.0618	0.2027
00	67.43	0.0779	0.2555
0	53.49	0.0983	0.3224
1	42.41	0.1239	0.4064
2	33.62	0.1563	0.5127
3	26.67	0.1970	0.6462
4	21.15	0.2485	0.8151
5	16.77	0.3133	1.0276
6	13.30	0.3951	1.2959
7	10.55	0.4982	1.6341
8	8.37	0.6282	2.0605
9	6.63	0.7921	2.5981
10	5.26	0.9989	3.2764
11	4.17	1.2600	4.1328
12	3.31	1.5880	5.2086
13	2.63	2.0030	6.5698
14	2.08	2.5250	8.2820

➤ Choose the right controller for the system

- Rated Solar Current should be more than Rated Power of Solar Panel.
- Rated Load Current should be sufficient to cover overall load current.

➤ Choose right Inverter for the system

- Make sure input voltage and out put voltage for the system.
- Rated Load Current should be sufficient to cover overall load current.



## The sample list of wind and solar power components available in the market

### ➤ Wind Turbines

Model No.	Descriptions
Southwest Windpower ( <a href="http://www.windenergy.com/index_wind.htm">http://www.windenergy.com/index_wind.htm</a> )	
Air-X Land-12	Wind Turbine, Rated Power 400 watts at 28 mph /12.5 m/s
WHISPER 100	Wind Turbine, Rated Power: 900 watts at 28 mph / 12.5 m/s
WHISPER 200	Wind Turbine, Rated Power: 1000 watts at 26 mph / 11.6 m/s
Zephyr ( <a href="http://www.itca.co.jp/zephyr.pdf">http://www.itca.co.jp/zephyr.pdf</a> )	
Z-1000	Wind Turbine, Rated Power: 1kW at 12.5m/s

### ➤ Solar panels

Model No.	Descriptions
SHELL SQ SERIES	
SQ70	Solar panel, maximum output power: 70W
SQ75	Solar panel, maximum output power: 75W
SQ80-P	Solar panel, maximum output power: 80W
SQ85-P	Solar panel, maximum output power: 85W
Sharp ( <a href="http://www.sharppusa.com/solar">www.sharppusa.com/solar</a> )	
NE-80 EJE A	Solar panel, maximum output power: 80W
NE-123UJF	Solar panel, maximum output power: 123W

### ➤ Controllers and other components

Model No.	Descriptions
Morningstar ( <a href="http://www.morningstarcorp.com">www.morningstarcorp.com</a> )	
PS-30M	Solar Charge Controller, Rated Solar Current: 30A
TriStar-45	Three-function Solar Controller, Rated Solar Current: 45A
TriStar-60	Three-function Solar Controller, Rated Solar Current: 60A
SureSine™	Pure Sine Wave Inverter, output power: 300w
Zephyr ( <a href="http://www.itca.co.jp/zephyr.pdf">http://www.itca.co.jp/zephyr.pdf</a> )	
PC-100	Power controller, Rated output power: 1440W
PV-100	Solar battery controller, Rated output power: 1440W
HS-600-12	DC/AC inverter, Continuous output: 600W
HS-350-12	DC/AC inverter, Continuous output: 350W
Xantrex Technology ( <a href="http://www.xantrex.com/index.asp">http://www.xantrex.com/index.asp</a> )	
C35	Solar Charge Controller, Rated Solar Current: 35A
XPower Inverter 300	230 VAC/50 Hz, output power: 300W
XPower Inverter 500	230 VAC/50 Hz, output power: 500W

**NOTE:** The above listed components were available when we prepared this material. However as we do not control availability of these products there is the possibility they may no longer be available. Please contact the local supplier for availability of the above components if necessary.

## ☐ Troubleshooting

The following chart is designed to help correct problems which are not equipment malfunctions.

If you are unable to locate the cause of a problem or solve it through the use of this chart, contact the nearest Icom Dealer or Service Center

PROBLEM	POSSIBLE CAUSE	SOLUTION	REF.
Power does not come on when <b>[POWER]</b> switch is ON.	<ul style="list-style-type: none"> <li>• DC power cable is improperly connected.</li> <li>• Fuse is blown.</li> </ul>	<ul style="list-style-type: none"> <li>• Re-connect the DC power cable correctly.</li> <li>• Check the cause, then replace the fuse with a spare one.</li> </ul>	
No sounds from the speaker.	<ul style="list-style-type: none"> <li>• Volume level is too low.</li> <li>• The squelch is closed.</li> <li>• The audio mute function is activated.</li> <li>• A selective call or squelch function is activated such as 5 tone call or tone squelch.</li> <li>• The front speaker is set to OFF.</li> </ul>	<ul style="list-style-type: none"> <li>• Rotate <b>[VOLUME]</b> clockwise to obtain a suitable listening level.</li> <li>• While in base operating mode, rotate <b>[SELECT]</b> to counterclockwise to open the squelch. (When the [SQL Level Up/Down] key function is assigned) to [SELECT].)</li> <li>• Push <b>[MONI]</b> if assigned) to the audio mute function OFF.</li> <li>• Turn the appropriate function OFF.</li> <li>• Turn the front speaker ON using the optional CS-FR5000 cloning software. Ask your dealer for details.</li> </ul>	
Sensitivity is low and only strong signals are audible.	<ul style="list-style-type: none"> <li>• Antenna feedline or the antenna connector has a poor contact or short-circuited.</li> </ul>	<ul style="list-style-type: none"> <li>• Check and re-connect (or replace if necessary), the antenna feedline or antenna connector.</li> </ul>	
Received signal cannot be understood.	<ul style="list-style-type: none"> <li>• Optional voice scrambler is turned OFF.</li> <li>• Scrambler code is not set correctly.</li> </ul>	<ul style="list-style-type: none"> <li>• Turn the optional voice scrambler ON.</li> <li>• Reset the scrambler code.</li> </ul>	
Output power is too low.	<ul style="list-style-type: none"> <li>• Output power is set to Low.</li> </ul>	<ul style="list-style-type: none"> <li>• Push <b>[HIGH/LOW]</b> (if assigned) to select the High power.</li> </ul>	
No contact possible with another station.	<ul style="list-style-type: none"> <li>• The other station is using tone squelch.</li> <li>• While in base operating mode, the repeater is set to duplex.</li> </ul>	<ul style="list-style-type: none"> <li>• Turn the tone squelch function ON.</li> <li>• Set the repeater to simplex, when other transceiver is set to simplex.</li> </ul>	

## ☐ Fuse replacement

If a fuse blows or the repeater stops functioning, try to find the source of the problem, and replace the damaged fuse with a new, rated fuse.

**CAUTION:** DISCONNECT the DC power cable from the repeater. Otherwise, there is danger of electric shock and/or equipment damage.

## ❖ Line fuse replacement [DC13.6V version]

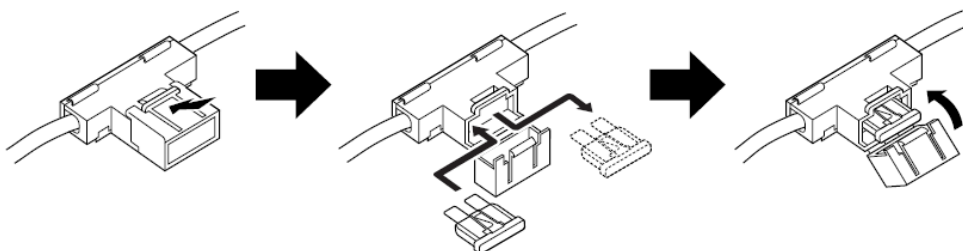

- The following Catalogues are available on the Icom web site.  
URL: <http://www.icom.co.jp/world/index.html>

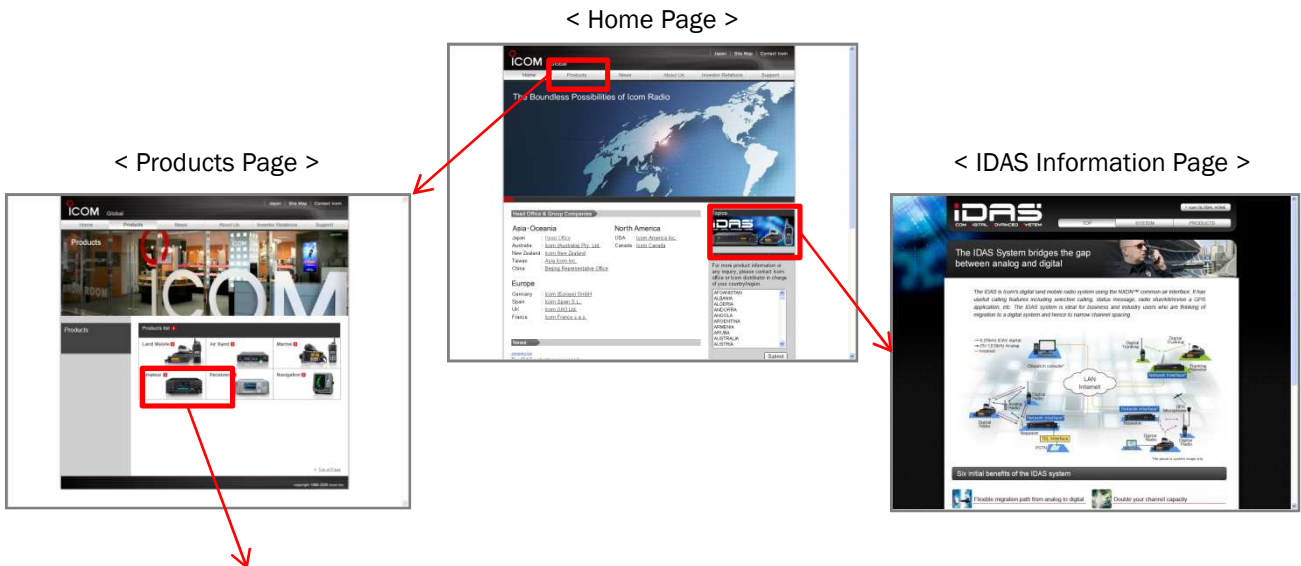

- The following Materials are available upon request through local Icom Distributors in your region.

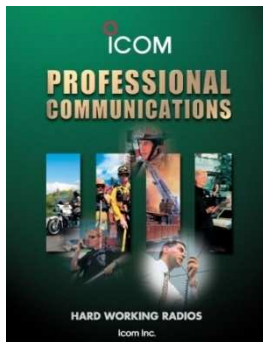

LMR  
Full line brochure



LMR Poster

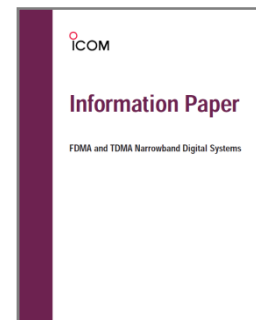

FDMA and TDMA  
Information Paper

- The following Instruction Manuals are available on the Icom web site.  
URL: <http://www.icom.co.jp/world/index.html>

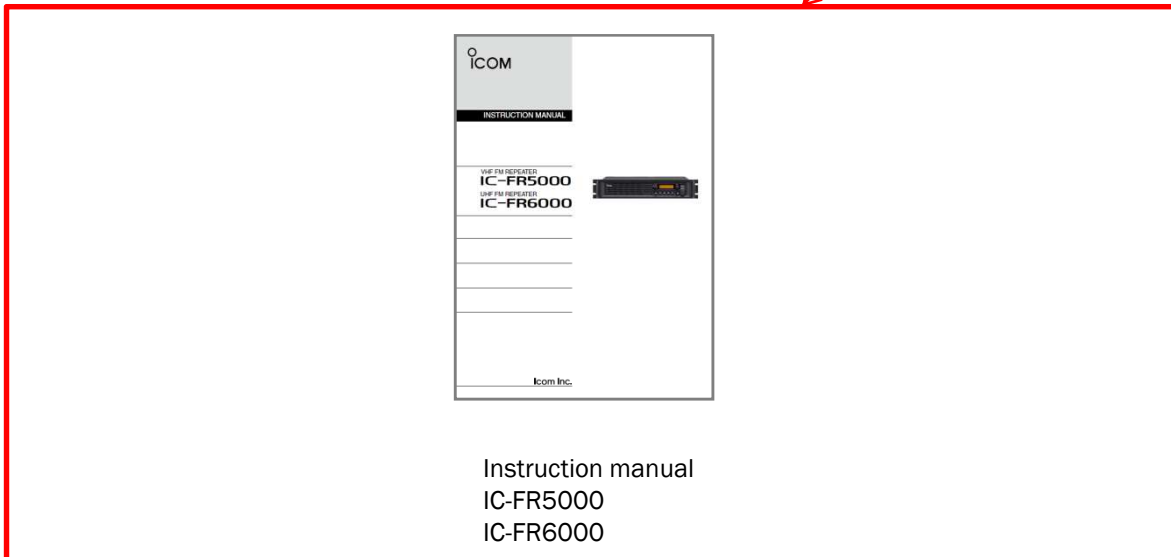
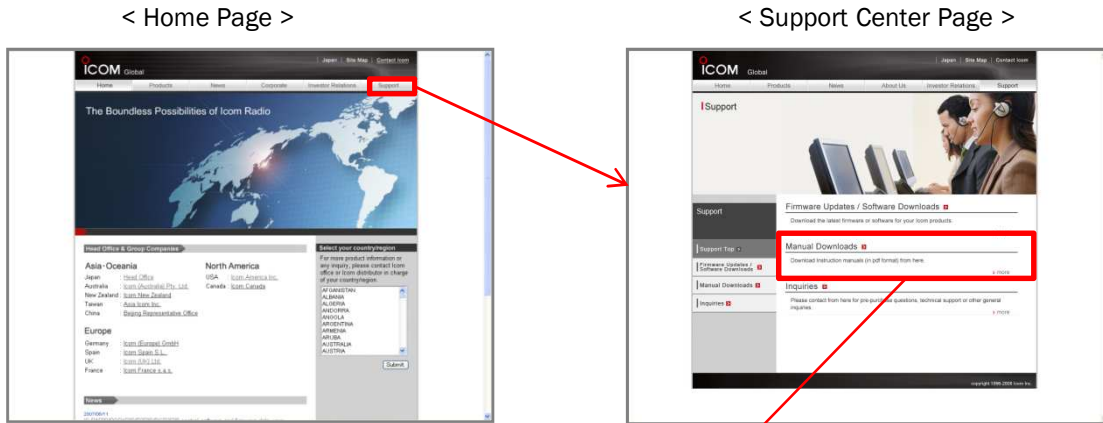

- The following Materials are available upon request through local Icom Distributors in your region.

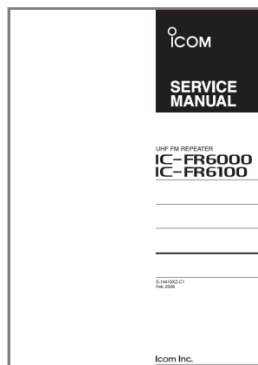

Service Manual  
IC-FR6000  
IC-FR6100





**Icom Inc.** 1-1-32, Kami-minami, Hirano-ku, Osaka 547-0003, Japan Phone: +81 (06) 6793 5302 Fax: +81 (06) 6793 0013 URL: <http://www.icom.co.jp/world/index.html> **Count on us!**

#### Icom America Inc.

2380 116th Avenue NE,  
Bellevue, WA 98004, U.S.A.  
Phone: +1 (425) 454-8155  
Fax: +1 (425) 454-1509  
E-mail: [sales@icomamerica.com](mailto:sales@icomamerica.com)  
URL: <http://www.icomamerica.com>

#### Icom Canada

Glenwood Centre #150-6165 Highway 17,  
Delta, B.C., V4K 5B8, Canada  
Phone: +1 (604) 952-4266  
Fax: +1 (604) 952-0090  
E-mail: [info@icomcanada.com](mailto:info@icomcanada.com)  
URL: <http://www.icomcanada.com>

#### Icom (Australia) Pty. Ltd.

Unit 1 / 103 Garden Road,  
Clayton VIC 3168 Australia  
Phone: +61 (03) 9549 7500  
Fax: +61 (03) 9549 7505  
E-mail: [sales@icom.net.au](mailto:sales@icom.net.au)  
URL: <http://www.icom.net.au>

#### Icom New Zealand

146A Harris Road, East Tamaki,  
Auckland, New Zealand  
Phone: +64 (09) 274 4062  
Fax: +64 (09) 274 4708  
E-mail: [inquiries@icom.co.nz](mailto:inquiries@icom.co.nz)  
URL: <http://www.icom.co.nz>

#### Icom (Europe) GmbH

Communication Equipment  
Himmelgeister Str. 100,  
D-40225 Düsseldorf, Germany  
Phone: +49 (0211) 346047  
Fax: +49 (0211) 339639  
E-mail: [info@icomeurope.com](mailto:info@icomeurope.com)  
URL: <http://www.icomeurope.com>

#### Icom Spain S.L.

Ctra. Rubi, No. 88 "Edificio Can Castanyer"  
08190, Sant Cugat del Valles, Barcelona, Spain  
Phone: +34 (93) 590 26 70  
Fax: +34 (93) 589 04 46  
E-mail: [icom@icomspain.com](mailto:icom@icomspain.com)  
URL: <http://www.icomspain.com>

#### Icom (UK) Ltd.

Unit 9, Sea St., Herne Bay,  
Kent, CT6 8LD, U.K.  
Phone: +44 (01227) 741741  
Fax: +44 (01227) 741742  
E-mail: [info@icomuk.co.uk](mailto:info@icomuk.co.uk)  
URL: <http://www.icomuk.co.uk>

#### Icom France s.a.s.

Zac de la Plaine,  
1 Rue Brindejonc des Moulinais, BP 45804,  
31505 Toulouse Cedex 5, France  
Phone: +33 (5) 61 36 03 03  
Fax: +33 (5) 61 36 03 00  
E-mail: [icom@icom-france.com](mailto:icom@icom-france.com)  
URL: <http://www.icom-france.com>

#### Icom Polska

Sopot, 3 maja 54, Poland  
Phone: +48 (58) 550 7135  
Fax: +48 (58) 551 0484  
E-mail: [icompolska@icompolska.com.pl](mailto:icompolska@icompolska.com.pl)  
URL: <http://www.icompolska.com.pl>

#### Asia Icom Inc.

6F No. 68, Sec. 1 Cheng-Teh Road,  
Taipei, Taiwan, R.O.C.  
Phone: +886 (02) 2559 1699  
Fax: +886 (02) 2559 1874  
E-mail: [sales@asia-icom.com](mailto:sales@asia-icom.com)  
URL: <http://www.asia-icom.com>

#### Beijing Icom Ltd.

10C07, Long Silver Mansion, No.88, Yong Ding  
Road, Haidian District, Beijing, 100039, China  
Phone: +86 (010) 5889 5391/5392/5393  
Fax: +86 (010) 5889 5395  
E-mail: [bjicom@bjicom.com](mailto:bjicom@bjicom.com)  
URL: <http://www.bjicom.com>

Your local distributor/dealer: