

INTRODUCTION

About this Instruction Manual (PDF format)

These Instruction Manual describe the details of the IC-V80/IC-V80E and IC-U80/IC-U80E's features. And, this PDF formatted manual provides you with convenient functions, as follows.

Move to the previously read page.

Click [Previous view] at the left top on an each page, to move back to the previously read page.

Shows the location of keys

When the cursor is moved over a term with a red underline, a red circle appears around the appropriate key(s) on the figure of transceiver.

Shows a term description

When the mouse cursor is moved over a term which is highlighted in yellow, the description of term is displayed.

Example: When the cursor is moved over **[FUNC](*)** in the description, a red circle appears around the appropriate key(s).

The screen shots at the right column, correspond to the operating instructions and procedures shows both setting and operating example.

Previous view
8 TONE SQUELCH AND POCKET BEEP

■ Tone scan

By monitoring a signal that is being operated with the pocket beep, tone or DTCS Squelch function turned ON, you can determine the tone frequency or DTCS code necessary to open the squelch.

- Set a frequency or select a memory channel to check for a tone frequency or DTCS code.
- Push **[FUNC](*)** and then push **[TONE](1)** several times. **When the icon of desired Tone function is displayed.**
 - For the CTCSS tone scan:

Item

Continually sweeping frequencies looking for signals.

- When the CTCSS tone frequency or DTCS code is detected, the squelch opens and the detected tone frequency is temporarily programmed into the selected mode.
 - The detected CTCSS tone frequency or DTCS code is used for the tone encoder or decoder, depending on the tone condition or type selected in step 2).
 - No icon : Cannot be used for the operation.
 - T² : Repeater tone encoder
 - T² + W : DTCS encoder (Only TX)
 - C : DTCS tone encoder or decoder
 - W : DTCS code encoder or decoder
- To cancel the scan, push any key except **[MONI]** or **[FUNC](*)**.



[i.e.]: A DTCS code scan on 145.20 MHz.

Set the operating frequency.

Push **[FREQ]** and then push **[TONE]** several times to select the DTCS squelch function.

Push **[FREQ]** and then push **[TONE]**.

Appears

During the DTCS code scan.

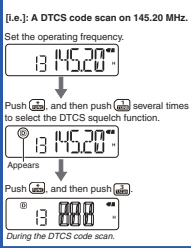

INTRODUCTION

Functions and features of Adobe® Reader®

The following functions and features can be used with Adobe® Reader®.

• Keyword search

Click “Find (Ctrl+F)” or “Advanced Search (Shift+Ctrl+F)” in the Edit menu to open the search screen. This is convenient when searching for a particular word or phrase in this manual.

*The menu screen may differ, depending on the Adobe® Reader® version.

Click to open the find or search screen or advanced search screen.

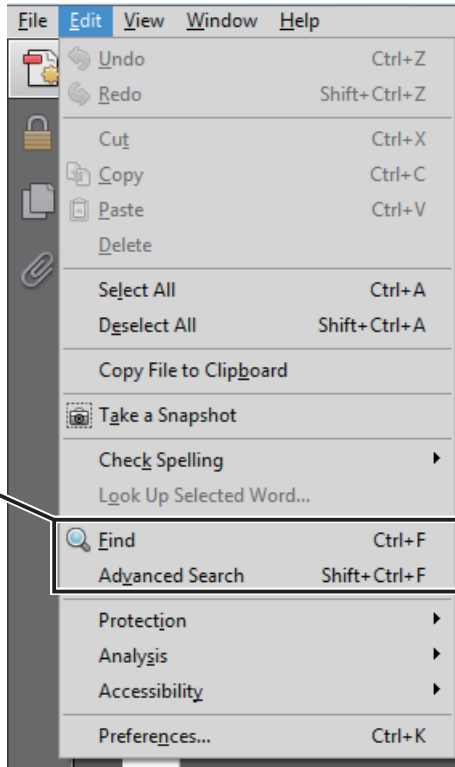

• Find screen

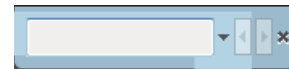

• Advanced search screen

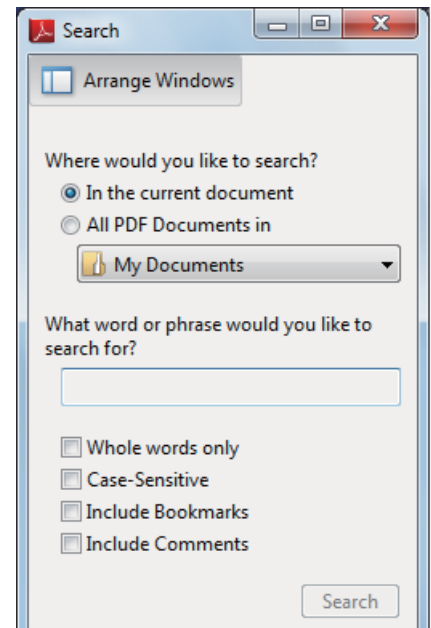

• Printing out the desired pages.

Click “Print (P)” in File menu, and then select the paper size and number of copies you want to print.

*The printing setup may differ, depending on the printer. Refer to your printer’s instruction manual for details.

*Select "A4" size to print out the page in the equalized size.

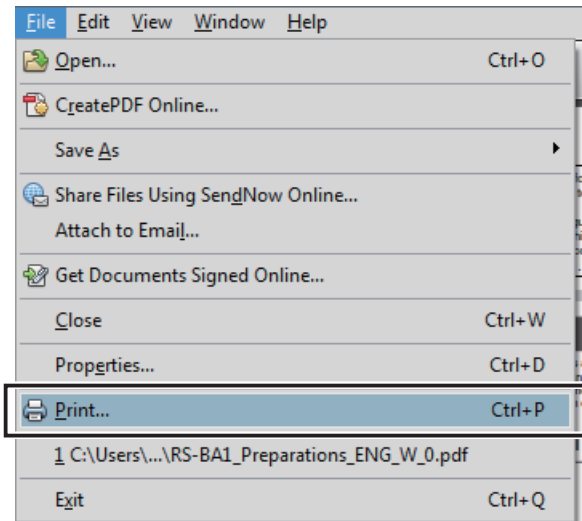

• Read Out Loud feature.

The Read Out Loud feature reads aloud the text in this Instruction Manual.

Refer to the Adobe® Reader® Help for the details. (This feature cannot be used, depending on your PC environment including operating system.)

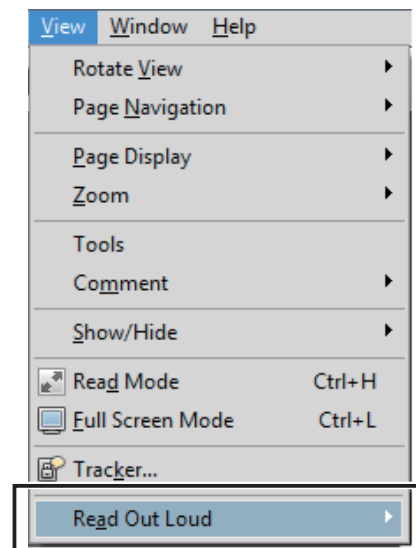

*The screen may differ, depending on the Adobe® Reader® version.



INSTRUCTION MANUAL

VHF TRANSCEIVERS

IC-V80
IC-V80E

UHF TRANSCEIVERS

IC-U80
IC-U80E

- 1 ACCESSORIES
- 2 PANEL DESCRIPTION
- 3 BATTERY CHARGING
- 4 BASIC OPERATION
- 5 REPEATER AND DUPLEX OPERATIONS
- 6 MEMORY/CALL OPERATION
- 7 SCAN OPERATION
- 8 TONE SQUELCH AND POCKET BEEP
- 9 DTMF MEMORY
- 10 SET MODES
- 11 CLONING
- 12 RESETTING
- 13 TROUBLE SHOOTING
- 14 OPTIONS
- 15 SPECIFICATIONS

FOREWORD

Thank you for purchasing this fine Icom product. The IC-V80/IC-V80E VHF TRANSCEIVERS or IC-U80/IC-U80E UHF TRANSCEIVERS are designed and built with Icom's state of the art technology and craftsmanship. With proper care this radio should provide you with years of trouble-free operation.

FEATURES

- *Dust-protection/Splash-resistant construction (IP54*)*

*Only when the battery pack or case, antenna and jack cover are attached.

- *Built in VOX circuit enabling the VOX operation* (voice operated transmission)*

*To use the VOX operation, an optional headset and a plug adapter cable are additionally required.

IMPORTANT

READ ALL INSTRUCTIONS carefully and completely before using the transceiver.

SAVE THIS INSTRUCTION MANUAL— This instruction manual contains important operating instructions for the IC-V80/IC-V80E and IC-U80/IC-U80E.

EXPLICIT DEFINITIONS

WORD	DEFINITION
⚠ DANGER!	Personal death, serious injury or an explosion may occur.
⚠ WARNING!	Personal injury, fire hazard or electric shock may occur.
CAUTION	Equipment damage may occur.
NOTE	Recommended, only inconvenience. No risk of personal injury, fire or electric shock.

SUPPLIED ACCESSORIES

The following accessories are supplied with the transceiver.

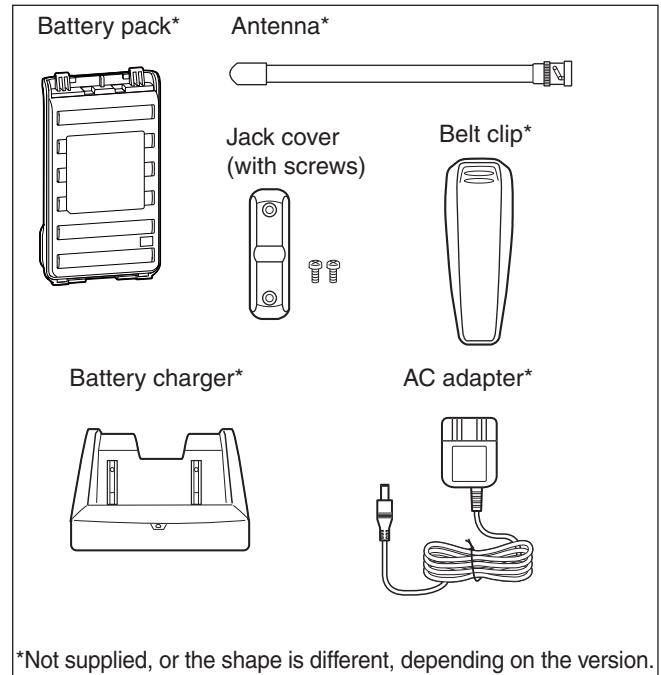

Icom, Icom Inc. and the Icom logo are registered trademarks of Icom Incorporated (Japan) in Japan, the United States, the United Kingdom, Germany, France, Spain, Russia and/or other countries.

Microsoft, Windows and Windows Vista are registered trademarks of Microsoft Corporation in the United States and/or other countries.

PRECAUTIONS

⚠ **DANGER! USE** the battery only with the transceiver for which it is specified. Never use a battery with any other equipment, or for any purpose that is not specified in the instruction manual.

⚠ **DANGER! NEVER** short the terminals of the battery pack.

⚠ **WARNING RF EXPOSURE!** This device emits Radio Frequency (RF) energy. Caution should be observed when operating this device. If you have any questions regarding RF exposure and safety standards, please refer to the Federal Communications Commission Office of Engineering and Technology's report on Evaluating Compliance with FCC Guidelines for Human Radio Frequency Electromagnetic Fields (OET Bulletin 65).

⚠ **WARNING! NEVER** hold the transceiver so that the antenna is very close to, or touching exposed parts of the body, especially the face or eyes, while transmitting. The transceiver will perform best if the microphone is 5 to 10 cm (2 to 4 inches) away from the lips and the transceiver is vertical.

⚠ **WARNING! NEVER** operate the transceiver with a headset or other audio accessories at high audio levels. Hearing experts advise against continuous high volume operation. If you experience a ringing in your ears, reduce the audio level or discontinue use.

⚠ **WARNING! NEVER** operate the transceiver while driving a vehicle. Safe driving requires your full attention—anything less may result in an accident.

⚠ **WARNING! NEVER** operate or touch the transceiver with wet hands. This may result in an electric shock or damage the transceiver.

DO NOT operate the transceiver near unshielded electrical blasting caps or in an explosive atmosphere.

DO NOT push [PTT] when not actually intending to transmit.

BE CAREFUL! The transceiver will become hot when operating it continuously for long periods of time.

DO NOT use or place the transceiver in direct sunlight or in areas with temperatures below -20°C (-4°F) or above $+60^{\circ}\text{C}$ ($+140^{\circ}\text{F}$).

KEEP the transceiver out of the reach of children.

DO NOT use harsh solvents such as benzine or alcohol when cleaning, as they will damage the transceiver's surfaces.

DO NOT disassemble or modify the transceiver. The transceiver warranty does not cover any problems caused by unauthorized modification.

KEEP the transceiver away from heavy rain, and never immerse it in the water. The transceiver meets IP54* requirements for dust-protection and splash resistance. However, once the transceiver has been dropped, dust-protection and splash resistance cannot be guaranteed because of possible damage to the transceiver's case or the waterproof seal.

*Only when the battery pack or case, antenna and jack cover are attached.

Even when the transceiver power is OFF, a slight current still flows in the circuits. Remove the battery pack or case from the transceiver when not using it for a long time. Otherwise, the battery pack or installed dry cell batteries will become exhausted.

TABLE OF CONTENTS

FOREWORD	i	8 TONE SQUELCH AND POCKET BEEP	30–32
FEATURES	i	■ Tone/DTCS squelch and Pocket beep	30
IMPORTANT	i	■ Pocket beep	31
EXPLICIT DEFINITIONS	i	■ Tone scan	32
SUPPLIED ACCESSORIES	i	9 DTMF MEMORY	33–35
PRECAUTIONS	ii	■ Programming a DTMF code sequence	33
TABLE OF CONTENTS	iii	■ Transmitting a DTMF code sequence	34
		■ Monitoring a DTMF memory	35
1 ACCESSORIES	1	■ Setting DTMF transfer speed	35
■ Antenna	1	10 SET MODES	36–44
■ Belt clip	1	■ Set mode programming	36
■ Battery pack or case	1	■ Set mode items	38
■ Jack cover	1	■ Initial Set mode programming	40
2 PANEL DESCRIPTION	2–4	■ Initial Set mode items	42
■ Front, top and side panels	2	11 CLONING	45
■ Function display	4	■ Cloning operation	45
3 BATTERY CHARGING	5–10	12 RESETTING	46
■ Caution (for the BP-264 Ni-MH battery)	5	■ Resetting	46
■ Caution (for the BP-265 Li-ion battery)	5	13 TROUBLE SHOOTING	47
■ Battery chargers	7	14 OPTIONS	48–50
■ Battery case (BP-263)	9	■ VOX function	49
■ Battery information	10	15 SPECIFICATIONS	51
4 BASIC OPERATION	11–16	■ IC-V80/IC-V80E	51
■ Power ON	11	■ IC-U80/IC-U80E	52
■ Adjusting the audio level	11		
■ Adjusting the squelch level	11		
■ Monitor function	11		
■ Selecting mode	12		
■ Selecting passband width	13		
■ Selecting a tuning step	13		
■ Setting a frequency	13		
■ Receiving	14		
■ Transmitting	14		
■ Key Lock function	15		
■ [VOL] function assignment	15		
■ Selecting output power	15		
■ Weather channel operation (Only USA version of IC-V80)	16		
5 REPEATER AND DUPLEX OPERATIONS	17–20		
■ Accessing a repeater	17		
■ Duplex operation	18		
■ Subaudible tones	19		
■ Lockout function	20		
■ Auto Repeater function (Only USA version of IC-V80)	20		
6 MEMORY/CALL OPERATION	21–25		
■ General description	21		
■ Programming memory/Call channel	21		
■ Selecting a memory channel	22		
■ Selecting the Call channel	22		
■ Copying memory/Call contents	23		
■ Clearing memory contents	24		
■ Display type	24		
■ Programming a channel name	25		
7 SCAN OPERATION	26–29		
■ Scan types	26		
■ Band edge to band edge scan (Full scan)	26		
■ Programmed scan	27		
■ Memory Scan	28		
■ Setting skip channels	28		
■ Scan resume setting	28		
■ Priority watch	29		

1 ACCESSORIES

■ Antenna

Insert the antenna into the antenna connector and twist the antenna base to lock it in place.

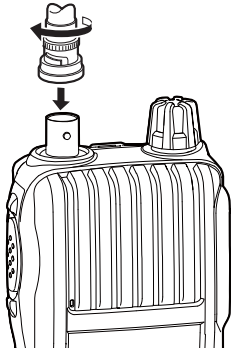

CAUTION:

- NEVER HOLD just the antenna when carrying the transceiver.
- Transmitting without an antenna will damage the transceiver.

■ Belt clip

To attach the belt clip:

Slide the belt clip in the direction of the arrow until the belt clip locks in place, and makes a 'click' sound.

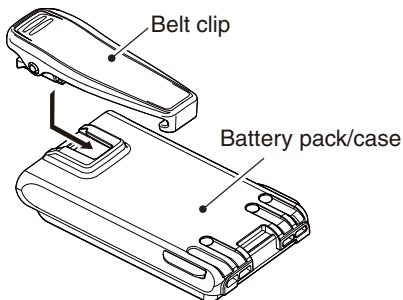

To detach the belt clip:

- ① Remove the battery pack or case from the transceiver, if it is attached.
- ② Lift the tab up (1), and slide the belt clip in the direction of the arrow (2).

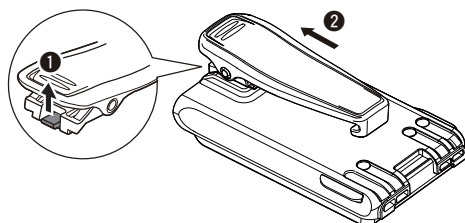

■ Battery pack or case

To attach the battery pack or case:

- ① Fit the battery pack or case in the direction of the arrow (1), then close.
- ② Hook the latch until it makes a 'click' sound (2).

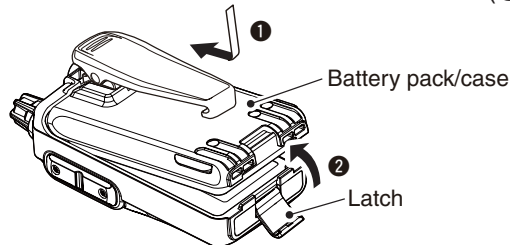

To remove the battery pack or case:

WARNING! The latch is tightly locked, so use caution when releasing it. **DO NOT** use your fingernail. Use the edge of a coin or screwdriver tip to carefully release it.

Unhook the latch (1), and then lift up the battery pack or case in the direction of the arrow (2).

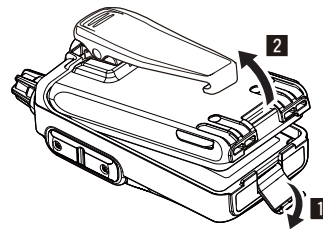

CAUTION: NEVER remove or attach the battery pack or case when the transceiver is wet or soiled. This may result in water or dust getting into the transceiver or the battery pack or case, and may result in them being damaged.

NOTE: Keep battery terminals clean. It's a good idea to occasionally clean them.

■ Jack cover

Attach the jack cover when optional equipment is not used.

To attach the jack cover

- ① Attach the jack cover to the [SP MIC] jack.
- ② Insert and tighten the screws.

To detach the jack cover

- ① Remove the screws with a phillips screwdriver.
- ② Detach the jack cover to connect optional equipment.

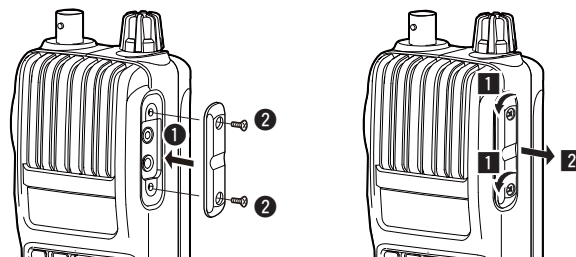

■ Front, top and side panels

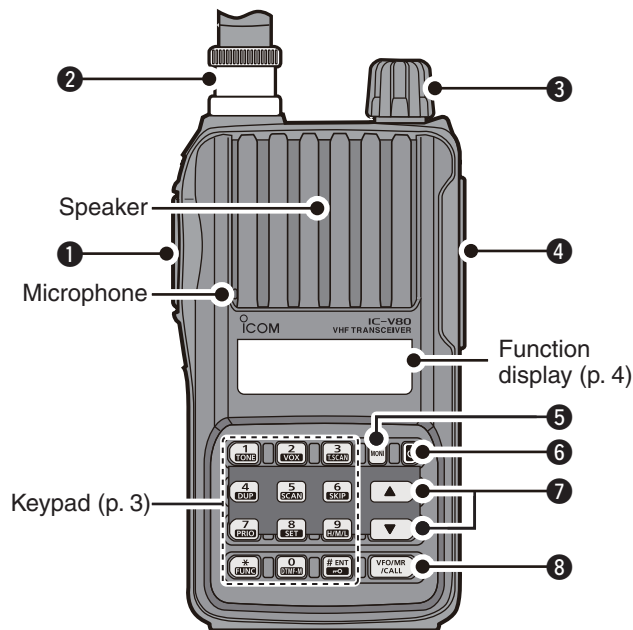

1 PTT SWITCH [PTT]

- Hold down to transmit, release to receive. (p. 14)
- For IC-V80E only**
- Quickly push [PTT] once, then immediately hold down [PTT] again for 1 or 2 seconds, to transmit a 1750 Hz tone burst signal. (p. 19)

2 ANTENNA CONNECTOR

Connect an antenna here. (p. 1)

3 CONTROL DIAL [VOL]

- Adjust the audio level. (p. 11)
- While in the Set mode, or Initial Set mode, rotate to select the desired item, option or value. (pp. 36, 40)

4 EXTERNAL SPEAKER/MICROPHONE JACKS [SP MIC]

Accepts an optional speaker-microphone, plug adapter cable or cloning cable connector. The internal microphone and speaker will not function when an option is connected.

CAUTION: Be sure to turn OFF the transceiver power, before connecting or disconnecting optional equipment to or from the [SP/MIC] jack.

5 MONITOR KEY [MONI]

- Hold down to temporarily open the squelch to monitor the operating frequency. (p. 11)
- While holding down the key, push [▲] or [▼] to adjust the squelch level. (p. 11)
- Enters or sends the **DTMF** code 'A.'

6 POWER KEY [⏻]

Hold down for 1 second to turn the power ON or OFF.

7 UP/DOWN KEYS [▲]/[▼]

- Push to change the operating frequency. (p. 13)
- In the memory mode, push to select a memory channel. (p. 22)
- While scanning, push to change the scanning direction. (pp. 26, 32)
- While holding down [MONI], push to adjust the squelch level. (p. 11)
- While in the Set mode, or Initial Set mode, push to select a setting item. (pp. 36, 40)
- [▲] enters or sends the DTMF code 'B.'
- [▼] enters or sends the DTMF code 'C.'

8 VFO/MEMORY/CALL KEY [VFO/MR/CALL]

- Push to sequentially select the VFO mode, memory mode, a Call channel or a weather channel*. (p. 12)
- *For only USA version of IC-V80.
- After pushing [FUNC](*), push to enter the memory programming mode. (p. 21)
- After pushing [FUNC](*), hold down for 1 second to transfer a channel's contents to a memory channel, or to the VFO mode. (p. 23)
- Enters or sends the DTMF code 'D.'

2 PANEL DESCRIPTION

◇ KEYPAD

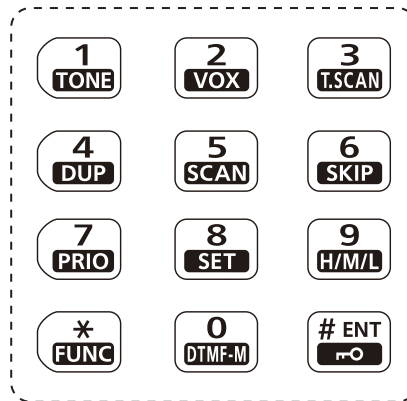

- ➔ While in the VFO mode, push to enter numbers for frequency input.
- ➔ While in the memory mode, push to enter numbers to select a memory channel.
- ➔ Push to enter or send a **DTMF** code. (pp. 33, 34)
- ➔ To activate the second function of a key, first push **[FUNC](*)**, and then push the key.

1 [1] • **[TONE](1)**
 ➔ Numeric input and DTMF code: '1'
 ➔ After pushing **[FUNC](*)**, selects a Tone function. (p. 31)

2 [2] • **[VOX](2)**
 ➔ Numeric input and DTMF code: '2'
 ➔ After pushing **[FUNC](*)**, turns the VOX function ON or OFF*. (p. 49)
 * Only when an optional headset and plug adapter are connected.

3 [3] • **[T.SCAN](3)**
 ➔ Numeric input and DTMF code: '3'
 ➔ After pushing **[FUNC](*)**, starts a tone **scan**. (p. 32)

4 [4] • **[DUP](4)**
 ➔ Numeric input and DTMF code: '4'
 ➔ After pushing **[FUNC](*)**, selects minus **duplex**, plus duplex, or **simplex** operation. (p. 18)

5 [5] • **[SCAN](5)**
 ➔ Numeric input and DTMF code: '5'
 ➔ After pushing **[FUNC](*)**, starts a scan. (p. 26)

6 [6] • **[SKIP](6)**
 ➔ Numeric input and DTMF code: '6'
 ➔ After pushing **[FUNC](*)**, sets or cancels the skip setting. (p. 28)

7 [7] • **[PRIO](7)**
 ➔ Numeric input and DTMF code: '7'
 ➔ After pushing **[FUNC](*)**, starts a **priority watch**. (p. 29)

8 [8] • **[SET](8)**
 ➔ Numeric input and DTMF code: '8'
 ➔ After pushing **[FUNC](*)**, enters the Set mode. (p. 36)

9 [9] • **[H/M/L](9)**
 ➔ Numeric input and DTMF code: '9'
 ➔ After pushing **[FUNC](*)**, selects high, mid or low output power. (p. 15)

0 [0] • **[DTMF-M](0)**
 ➔ Numeric input and DTMF code: '0'
 ➔ After pushing **[FUNC](*)**, enters the DTMF memory mode. (p. 33)

***** [**FUNC**] • **[FUNC](*)**
 ➔ DTMF code: '*' (indication: E)
 ➔ Push to access the second function of other keys.

ENT [**r-O**] • **[# ENT]**
 ➔ DTMF code: '#' (indication: F)
 ➔ After entering a frequency, push to save it. (p. 13)
 ➔ Push to exit the Set mode or Initial Set mode. (pp. 36, 40)
 ➔ After pushing **[FUNC](*)**, hold down for 1 second to turn the Key Lock function ON or OFF. (p. 15)

2 PANEL DESCRIPTION

■ Function display

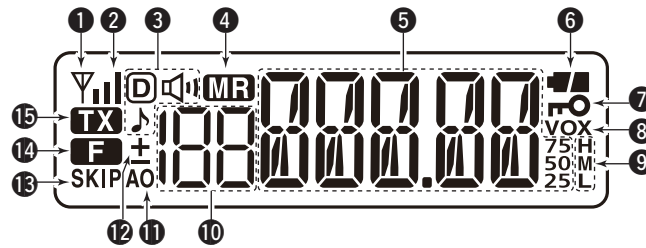

1 BUSY ICON

- Appears when a signal is being received, or the squelch is open. (p. 14)
- Blinks when the Monitor function is ON. (p. 11)

2 SIGNAL ICON

- Shows the strength of the received signal.



Weak ⇄ RX Signal level ⇄ Strong

- While transmitting, shows the output power level.



3 TONE ICONS

Appear when the Tone function is turned ON, and indicate which Tone function is in use. (p. 30)

"J"	Repeater tone encoder
"@" and "J"	DTCS encoder (Only TX)
"d"	CTCSS squelch function
"@"	DTCS squelch function
"H" and "d"	CTCSS Pocket beep function
"H" and "@"	DTCS Pocket beep function

4 MEMORY ICON

- Appears when the memory mode is selected. (p. 21)
- Blinks during a memory **scan**. (p. 28)

5 FREQUENCY READOUT

- Displays the operating frequency, memory channel, Set modes contents and a variety of other information.
 - The decimal point blinks during a scan.
- While in the memory mode, the programmed memory name can be displayed. (pp. 24, 25)

6 BATTERY ICONS

- "■" appears when the battery pack or case is attached. (p. 10)
- "■" appears when the battery is nearing exhaustion. When this appears, charging the battery pack, or replacing the batteries is necessary. (p. 5)

7 KEY LOCK ICON (p. 15)

Appears when the Key Lock function is ON.

8 VOX ICON (p. 49)

Appears when the VOX function is ON.

9 POWER ICON (p. 15)

- "H" appears when high power is selected.
- "M" appears when mid power is selected.
- "L" appears when low power is selected.

10 MEMORY CHANNEL NUMBER READOUT (p. 22)

- Displays the selected memory channel number.
- "C" appears when the Call channel is selected.

11 AUTO POWER OFF ICON (p. 42)

Appears when the Auto Power OFF function is ON.

12 DUPLEX ICON (p. 18)

- "+" appears when plus **duplex** is selected.
- "-" appears when minus duplex is selected.
 - No icon is displayed when **simplex** is selected.

13 SKIP ICON (p. 28)

Appears when the selected memory channel is set as a skip channel.

14 FUNCTION ICON

Appears when a second function can be accessed.

15 TRANSMIT ICON (p. 14)

Appears while transmitting.

■ Caution

◇ For the BP-264 Ni-MH battery

⚠ **DANGER! NEVER** incinerate used battery packs. Internal battery gas may cause an explosion.

⚠ **DANGER! NEVER** immerse the battery pack in water. If the battery pack becomes wet, be sure to wipe it dry **BEFORE** attaching it to the transceiver.

CAUTION: Always use the battery within the specified temperature range, -5°C to $+60^{\circ}\text{C}$ ($+23^{\circ}\text{F}$ to $+140^{\circ}\text{F}$). Using the battery out of its specified temperature range will reduce the battery's performance and battery life.

CAUTION: Shorter battery life could occur if the battery is left completely discharged, or in an excessive temperature environment (above $+55^{\circ}\text{C}$; $+131^{\circ}\text{F}$) for an extended period of time. If the battery must be left unused for a long time, it must be detached from the radio after charging. Keep it safely in a cool dry place at the following temperature range:

-20°C to $+45^{\circ}\text{C}$ (-4°F to $+113^{\circ}\text{F}$) (up to a month)

-20°C to $+35^{\circ}\text{C}$ (-4°F to $+95^{\circ}\text{F}$) (up to six months)

-20°C to $+25^{\circ}\text{C}$ (-4°F to $+77^{\circ}\text{F}$) (up to a year*)

* We recommend charging the battery pack every 6 months.

Clean the battery terminals to avoid rust or bad contact.

Keep battery terminals clean. It's a good idea to occasionally clean them.

If your **Ni-MH** battery pack seems to have no capacity, even after being charged, completely discharge it by leaving the power ON overnight. Then, fully charge the battery pack again. If the battery pack still does not retain a charge (or only very little charge), a new battery pack must be purchased.

Prior to using the transceiver for the first time, the battery pack must be fully charged for optimum life and operation.

- Recommended temperature range for charging: between $+10^{\circ}\text{C}$ and $+40^{\circ}\text{C}$ ($+50^{\circ}\text{F}$ to $+104^{\circ}\text{F}$) (rapid charge: with BC-191) or between 0°C and $+45^{\circ}\text{C}$ ($+32^{\circ}\text{F}$ to $+113^{\circ}\text{F}$) (regular charge: with BC-192)
- Use only the supplied charger or optional charger (BC-191 for rapid charging, BC-192 for regular charging). **NEVER** use other manufacturers' chargers.

The battery pack contains a rechargeable battery. Charge the battery pack before first operating the transceiver, or when the battery pack becomes exhausted. If you want to prolong the battery life, the following points should be observed:

- Avoid over charging. The charging time period should be less than 48 hours.
- Use the battery pack until it becomes almost completely exhausted, under normal conditions. We recommend battery charging just when transmitting becomes impossible.

◇ For the BP-265 Li-ion battery

Misuse of **Li-ion batteries** may result in the following hazards: smoke, fire, or the battery may rupture. Misuse can also cause damage to the battery or degradation of battery performance.

⚠ **DANGER!** Use and charge only specified Icom battery packs with Icom radios or Icom chargers. Only Icom battery packs are tested and approved for use with Icom radios or charged with Icom chargers. Using third-party or counterfeit battery packs or chargers may cause smoke, fire, or cause the battery to burst.

⚠ **DANGER! DO NOT** hit or otherwise impact the battery. Do not use the battery if it has been severely impacted or dropped, or if the battery has been subjected to heavy pressure. Battery damage may not be visible on the outside of the case. Even if the surface of the battery does not show cracks or any other damage, the cells inside the battery may rupture or catch fire.

⚠ **DANGER! NEVER** use or leave battery pack in areas with temperatures above $+60^{\circ}\text{C}$ ($+140^{\circ}\text{F}$). High temperature buildup in the battery, such as could occur near fires or stoves, inside a sun heated car, or in direct sunlight may cause the battery to rupture or catch fire. Excessive temperatures may also degrade battery performance or shorten battery life.

⚠ **DANGER! DO NOT** expose the battery to rain, snow, seawater, or any other liquids. Do not charge or use a wet battery. If the battery gets wet, be sure to wipe it dry before using.

⚠ **DANGER! NEVER** incinerate a used battery pack since internal battery gas may cause it to rupture, or may cause an explosion.

⚠ **DANGER! NEVER** solder the battery terminals, or **NEVER** modify the battery pack. This may cause heat generation, and the battery may burst, emit smoke or catch fire.

⚠ **DANGER!** If fluid from inside the battery gets in your eyes, blindness can result. Rinse your eyes with clean water, without rubbing them, and see a doctor immediately.

⚠ **WARNING!** Immediately stop using the battery if it emits an abnormal odor, heats up, or is discolored or deformed. If any of these conditions occur, contact your Icom dealer or distributor.

⚠ **WARNING!** Immediately wash, using clean water, any part of the body that comes into contact with fluid from inside the battery.

⚠ **WARNING! NEVER** put the battery in a microwave oven, high-pressure container, or in an induction heating cooker. This could cause a fire, overheating, or cause the battery to rupture.

(Continued on next page.)

3 BATTERY CHARGING

■ Caution (continued)

CAUTION: Always use the battery within the specified temperature range, -20°C to $+60^{\circ}\text{C}$ (-4°F to $+140^{\circ}\text{F}$). Using the battery out of its specified temperature range will reduce the battery's performance and battery life.

CAUTION: Shorter battery life could occur if the battery is left fully charged, completely discharged, or in an excessive temperature environment (above $+50^{\circ}\text{C}$; $+122^{\circ}\text{F}$) for an extended period of time. If the battery must be left unused for a long time, it must be detached from the radio after discharging. You may use the battery until the battery icon shows half-capacity, and then keep it safely in a cool dry place at the following temperature range:

-20°C to $+50^{\circ}\text{C}$ (-4°F to $+122^{\circ}\text{F}$) (up to a month)

-20°C to $+35^{\circ}\text{C}$ (-4°F to $+95^{\circ}\text{F}$) (up to three months)

-20°C to $+20^{\circ}\text{C}$ (-4°F to $+68^{\circ}\text{F}$) (up to a year)

◇ Charging caution

⚠ **DANGER! NEVER** charge the battery pack in areas with extremely high temperatures, such as near fires or stoves, inside a sun-heated vehicle, or in direct sunlight. In such environments, the safety/protection circuit in the battery will activate, causing the battery to stop charging.

⚠ **WARNING! DO NOT** charge or leave the battery in the battery charger beyond the specified time for charging. If the battery is not completely charged by the specified time, stop charging and remove the battery from the battery charger. Continuing to charge the battery beyond the specified time limit may cause a fire, overheating, or the battery may rupture.

⚠ **WARNING! NEVER** insert the transceiver (battery attached to the transceiver) into the charger if it is wet or soiled. This could corrode the battery charger terminals or damage the charger. The charger is not waterproof.

CAUTION: DO NOT charge the battery outside of the specified temperature range: BC-193 ($+10^{\circ}\text{C}$ to $+40^{\circ}\text{C}$; $+50^{\circ}\text{F}$ to $+104^{\circ}\text{F}$). Icom recommends charging the battery at $+20^{\circ}\text{C}$ ($+68^{\circ}\text{F}$). The battery may heat up or rupture if charged out of the specified temperature range. Additionally, battery performance or battery life may be reduced.

The supplied battery pack, charger, and AC adapter differ, or are not supplied, depending on the version.

Prior to using the transceiver for the first time, the battery pack must be fully charged for optimum life and operation.

3 BATTERY CHARGING

■ Battery chargers

◇ Using the BC-191 to rapid charge the BP-264

The BC-191 provides rapid charging of only the BP-264 Ni-MH battery pack. Never use it to charge any other battery pack.

Charging time: Approximately 2 hours

The following item is additionally required:

- An AC adapter (not supplied with some versions) or the OPC-515L or CP-23L DC power cable.

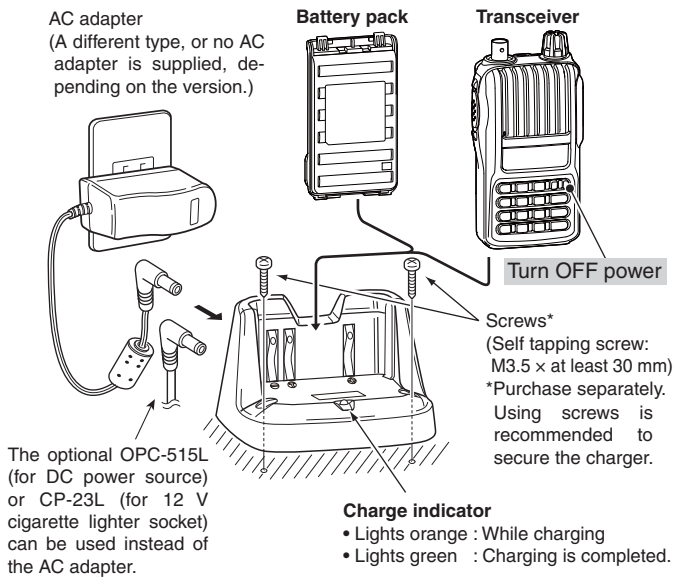

◇ Using the BC-192 to regular charge the BP-264

The BC-192 provides regular charging of only the BP-264 Ni-MH battery pack. Never use it to charge any other battery pack.

Charging time (with the BC-147S): Approximately 16 hours

The following item is additionally required:

- An AC adapter (not supplied with some versions) or the OPC-515L DC power cable.

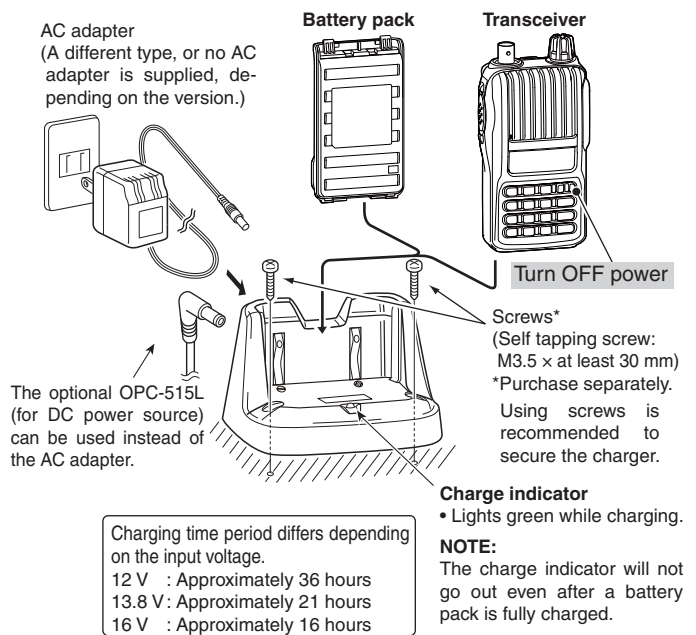

3 BATTERY CHARGING

◇ Using the BC-193 to rapid charge the BP-265

The BC-193 provides rapid charging of only the BP-265 **Li-ion battery** pack. Never use it to charge any other battery pack.

Charging time: Approximately 2.5 hours

The following item is additionally required:

- An AC adapter (not supplied with some versions) or the OPC-515L or CP-23L DC power cable.

/// IMPORTANT: Battery charging caution

Ensure the tabs on the battery pack are correctly aligned with the guide rails inside the charger.

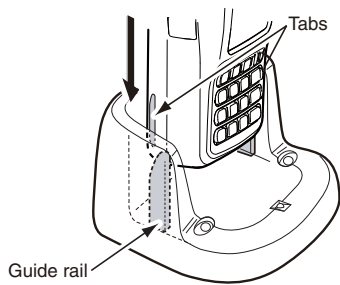

/// CAUTION: When using the OPC-515L DC power cable

NEVER connect the OPC-515L to a power source using reverse polarity. This will ruin the battery charger.

White line: ⊕ Black line: ⊖

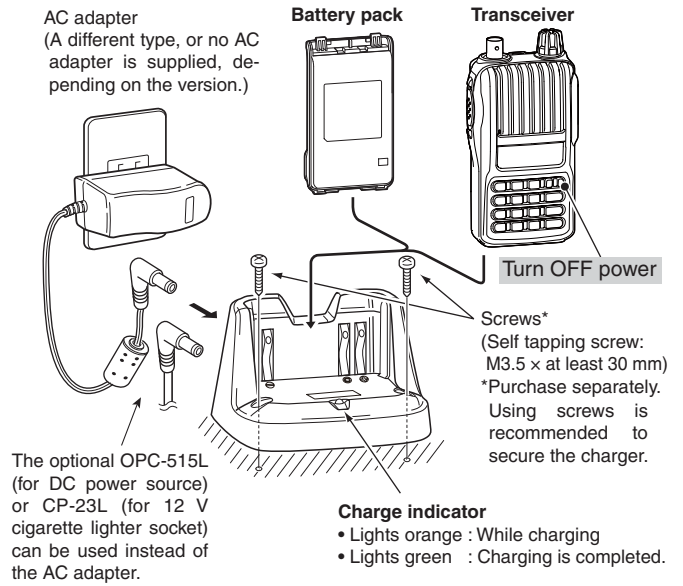

3 BATTERY CHARGING

■ Battery case (BP-263)

When using the battery case (BP-263), install 6 × AA (LR6) size alkaline batteries, as described below.

- ① Remove the battery case, if it is attached. (p. 1)
- ② Install 6 × AA (LR6) size alkaline batteries.
 - Install only alkaline batteries.
 - Be sure to observe the correct polarity.
- ③ Attach the battery case. (p. 1)

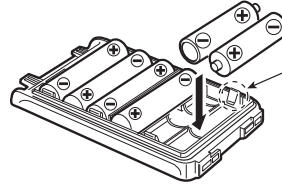

Be careful! The negative terminals of the battery case protrude from the body, so pay attention not to injure your fingers when inserting the batteries.

CAUTION:

- When installing batteries, make sure they are all the same brand, type and capacity. Also, do not mix new and old batteries together.
- Keep battery terminals clean. It's a good idea to occasionally clean them.
- Never incinerate used battery cells since the internal battery gas may cause them to rupture.
- Never expose a detached battery case to water. If the battery case gets wet, be sure to wipe it dry before using it.
- Never use batteries whose insulated covering is damaged.

NOTE: When the battery case is attached, the Battery Protection function must be turned OFF in the Initial Set mode (p. 44).

3 BATTERY CHARGING

■ Battery information

◇ Battery life

Battery pack or case	Voltage	Capacity	Battery life*1
BP-263	Battery case for AA (LR6) × 6 alkaline cells		—*2
BP-264	7.2 V	1400 mAh (min.) 1420 mAh (typ.)	13 hrs. (IC-V80/IC-V80E) 14.5 hrs. (IC-U80/IC-U80E)
BP-265	7.4 V	1900 mAh (min.) 2000 mAh (typ.)	19 hrs. (IC-V80/IC-V80E) 17.5 hrs. (IC-U80/IC-U80E)



*1 When the Power Save function is set to "P-S.At" (p. 43), and the operating time is calculated under the following ratio:

TX : RX : standby = 5 : 5 : 90

*2 The average operating life depends on the alkaline cells used.

Even when the transceiver power is OFF, a small amount of current still flows in the transceiver. Remove the battery pack or case when it won't be used for a long time. Otherwise, the battery pack or the batteries in the case will become exhausted.

◇ Battery icon

Icon	Battery condition
	The battery has ample capacity.
	The battery is nearing exhaustion. Charging the battery pack, or replacing the batteries in the case is necessary.

4 BASIC OPERATION

■ Power ON

➤ Hold down [⏻] for 1 second to turn the power ON or OFF.

• For only IC-U80/IC-U80E:

The voltage of the battery is displayed at power ON. This display can be turned ON or OFF in the Initial Set mode. (p. 44)

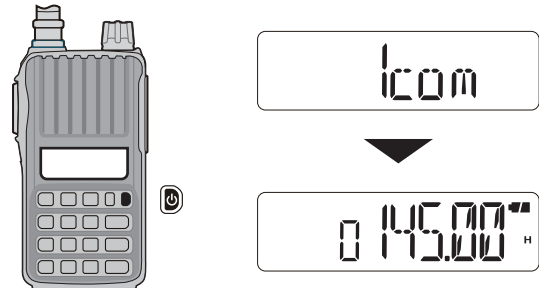

■ Adjusting the audio level

- Rotate [VOL] to adjust the audio level.
- The display shows the audio level while adjusting.
 - If the squelch is closed, hold down [MONI] while adjusting the audio level.

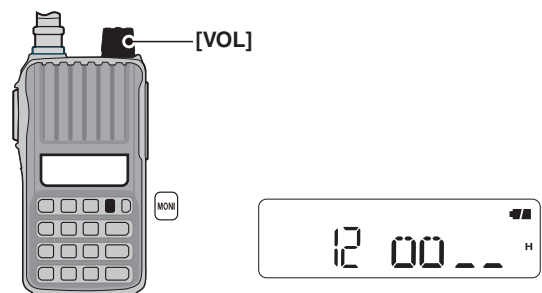

■ Adjusting the squelch level

- While holding down [MONI], push [▲] or [▼] several times to adjust the squelch level.
- "Sql 1" is loose squelch (for weak signals) and "Sql10" is tight squelch (for strong signals). "Sql 0" is open squelch.

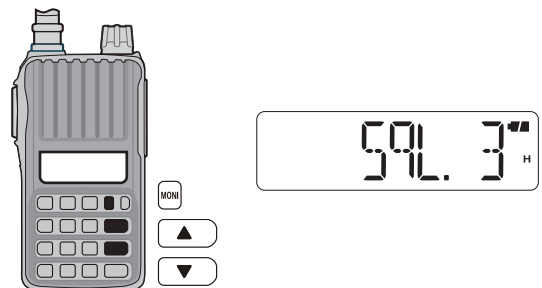

■ Monitor function

This function is used to listen to weak signals, or to manually open the squelch. You can use it without disturbing the squelch setting, even when mute functions such as the tone squelch are in use.

- Hold down [MONI] to open the squelch.
- Release [MONI] to cancel the function.

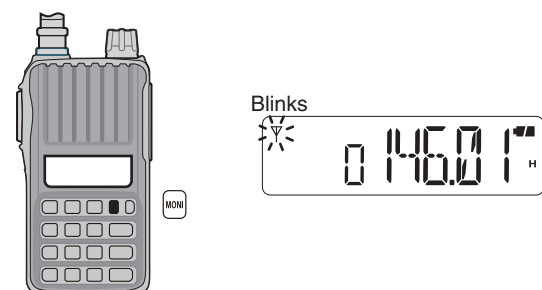

4 BASIC OPERATION

■ Selecting mode

The transceiver has 2 basic operating modes; **VFO** mode and memory mode.

➔ Push **[VFO/MR/CALL]** several times to sequentially select the VFO mode, memory mode, Call channel mode or weather channel mode*.

*For only USA version of IC-V80.

◇ VFO mode

The VFO mode is used to set the operating frequency.

What is VFO?

VFO is an abbreviation of Variable Frequency Oscillator. Frequencies for both transmitting and receiving are generated and controlled by the VFO.

◇ Memory mode

The memory mode is used to operate on memory channels, which store programmed frequencies.

- “**MR**” appears when the memory mode is selected.

◇ Call channel mode

The Call channel is used for quick recall of the most often-used frequency.

- “**C**” appears instead of the memory channel number, when the Call channel mode is selected.

◇ Weather channel mode Only USA version of IC-V80

There are 10 weather channels for monitoring weather broadcasts from NOAA (National Oceanic and Atmospheric Administration).

Push **[VFO/MR/CALL]** several times to select the desired operating mode.

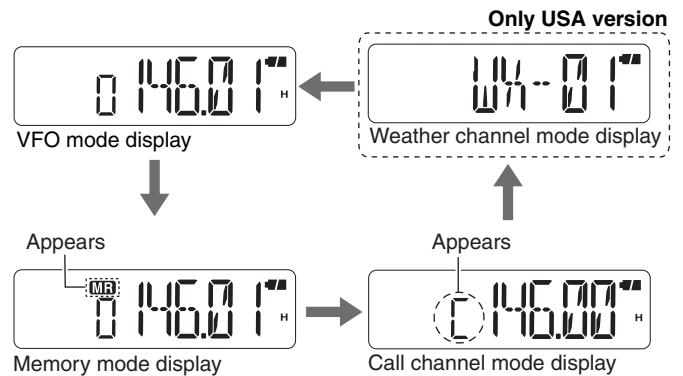

4 BASIC OPERATION

■ Selecting passband width

Set both the transmission and reception **passband width** to wide or narrow.

- ① Push **[FUNC](*)**, and then push **[SET](8)** to enter the Set mode.
- ② Push **[▲]** or **[▼]** to select the passband width item (W/n).
- ③ Rotate **[VOL]** to select the passband width.
 - “W” : Wide (FM mode).
 - “n” : Narrow (FM-N mode).
- ④ Push **[# ENT]** to exit the Set mode.

• The “Passband width” item in the Set mode

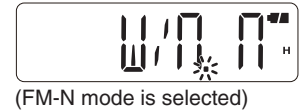

■ Selecting a tuning step

The transceiver has 8 tuning step options;

- 5 kHz • 10 kHz • 12.5 kHz • 15 kHz
- 20 kHz • 25 kHz • 30 kHz • 50 kHz

The tuning step can be selected in the Set mode.

- ① Push **[FUNC](*)**, and then push **[SET](8)** to enter the Set mode.
- ② Push **[▲]** or **[▼]** to select the tuning step item (tS).
- ③ Rotate **[VOL]** to select the desired tuning step.
- ④ Push **[# ENT]** to exit the Set mode.

• The “Tuning step” item in the Set mode

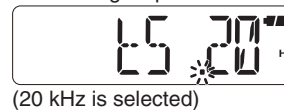

■ Setting a frequency

◇ Using **[▲]** or **[▼]**

- ① If necessary, push **[VFO/MR/CALL]** several times to select the **VFO mode**.
- ② Push **[▲]** or **[▼]** to set a frequency.
 - The frequency changes according to the selected tuning step.

• **Example — selecting 145.040 MHz**



◇ Using the keypad

- ① If necessary, push **[VFO/MR/CALL]** several times to select the VFO mode.
- ② To enter the desired frequency, enter 6 digits, starting from the 100 MHz digit.
 - Entering two or three* to five digits, and then pushing **[# ENT]**, also sets the frequency. (*Depending on the transceiver version)
 - If the entered frequency is outside of the frequency range, the previously displayed frequency is automatically recalled.

• **Example 1— entering 145.525 MHz**



• **Example 2— entering 144.800 MHz**



4 BASIC OPERATION

■ Receiving

- ① Hold down [PWR] for 1 second to turn ON the power.
 - The display shows the audio level while adjusting.
- ② Rotate [VOL] to adjust the desired audio level. (p. 11)
 - The display shows the audio level while adjusting.
- ③ Adjust the squelch level. (p. 11)
 - While holding down [MONI], push [▲] or [▼] several times to adjust the squelch level.
 - The display shows the squelch level while adjusting.
 - “Sql 1” is loose squelch (for weak signals) and “Sql10” is tight squelch (for strong signals). “Sql 0” is open squelch.
- ④ Set the operating frequency or memory channel. (pp. 13, 22)
- ⑤ When you receive a signal, the squelch opens and audio can be heard.
 - The signal icon shows the relative signal strength of the received signal.

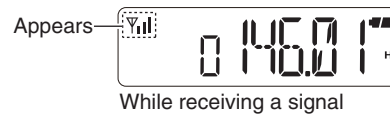
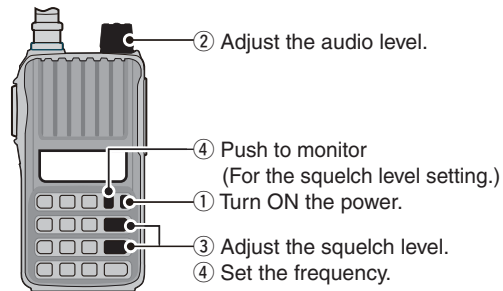

■ Transmitting

CAUTION: Transmitting without an antenna will damage the transceiver.

NOTE: To prevent interference, listen on the channel before transmitting by opening the squelch. To open the squelch, hold down [MONI].

- ① Set the operating frequency or memory channel. (pp. 13, 22)
 - Adjust the output power if desired. See page 15 for the details.
- ② Hold down [PTT] to transmit.
 - “TX” appears while transmitting.
 - The signal icon shows the output power level.
- ③ Speak into the microphone at your normal voice level.
 - DO NOT hold the transceiver too close to your mouth, or speak too loudly. This may distort the signal.
- ④ Release [PTT] to receive.

NOTE: When the TX permission is set to OFF, you cannot transmit. (p. 39)

⚠ WARNING! When using the BP-263 battery case, frequent or continuous transmissions can cause the batteries to overheat, and may cause a burn. Be careful of long transmissions when the Time-out Timer function is turned OFF, or set to a long time period.

- We recommend using the middle or low power setting.

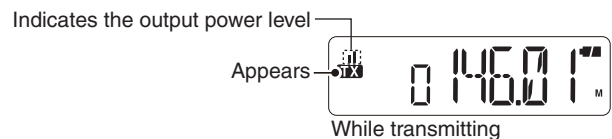
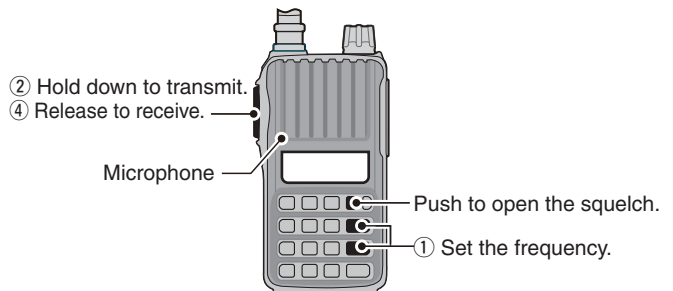

4 BASIC OPERATION

■ Key Lock function

Use the Key Lock function to prevent accidental frequency or channel change or unnecessary function access.

- ➔ Push **[FUNC](*)**, and then hold down **[\square](# ENT)** for 1 second to turn the Key Lock function ON or OFF.
 - “ \square ” appears while the Key Lock function is ON.
 - **[\square]**, **[VOL]**, **[MONI]**, **[PTT]** and **[FUNC](*) + [\square](# ENT)** are still operable while the Key Lock function is ON.

Push **[FUNC]**, and then hold down **[# ENT]** for 1 second.



■ [VOL] function assignment

[VOL] can be used as a tuning control instead of **[\blacktriangle]** and **[\blacktriangledown]**, to suit your preference. However, when **[VOL]** functions as a tuning control, **[\blacktriangle]** and **[\blacktriangledown]** function as volume controls.

- ① While holding down **[\blacktriangle]** and **[\blacktriangledown]**, turn ON the power to enter the Initial Set mode.
- ② Push **[\blacktriangle]** or **[\blacktriangledown]** to select the dial assignment item (tOP).
- ③ Rotate **[VOL]** to select an option.
- ④ Push **[# ENT]** to exit the Initial Set mode.

[VOL] and **[\blacktriangle]/**[\blacktriangledown]** function as described below, depending on the option.**

Option	[VOL]	[\blacktriangle]/[\blacktriangledown]
tOP.VO	Volume control	Tuning controls
tOP.di	Tuning control	Volume controls

- The “Dial assignment” item in the Set mode



[VOL] functions as the volume control.



[VOL] functions as the tuning control.

■ Selecting output power

The transceiver has 3 output power levels to suit your operating requirements. Lower output powers during short-distance communications may reduce the possibility of interference to other stations and will reduce current consumption.

- ➔ Push **[FUNC](*)**, and then push **[H/M/L](9)** several times to select the desired output power.

• OUTPUT POWER (approximately)

Level	Output power	
	IC-V80/V80E	IC-U80/U80E
Low	0.5 W	0.5 W
Mid	2.5 W	2.0 W
High	5.5 W	4.0 W

Push **[FUNC]**, and then push **[H/M/L]** several times to select the desired output power.

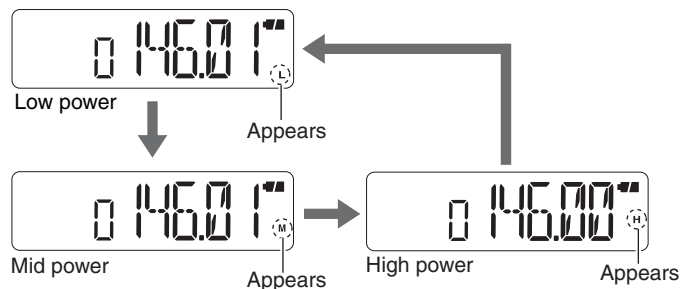

4 BASIC OPERATION

Weather channel operation

Only USA version of IC-V80

There are 10 weather channels for monitoring weather broadcasts from NOAA (National Oceanic and Atmospheric Administration).



Weather channel selection

- ① Push **[VFO/MR/CALL]** several times to select the weather channel mode.
- ② Push **[▲]** or **[▼]** to select the desired weather channel.
- ③ Push **[VFO/MR/CALL]** to return to the VFO, memory or Call channel mode.

Push **[VFO/MR/CALL]** several times to select the weather channel mode.



Push **[▲]** or **[▼]** to select a weather channel.



Weather Alert function

NOAA broadcast stations transmit weather alert tones before important weather announcements. When the Weather Alert function is turned ON, the transceiver checks the selected weather channel every 5 seconds for an announcement. When the alert signal is detected, the "AL.T" and the WX channel are displayed alternately and a beep tone sounds until the transceiver is operated. The selected (used) weather channel is checked periodically while in standby, or while scanning.

- ① Select the desired weather channel.
(See the above topic.)
- ② Push **[FUNC](*)**, and then push **[SET](8)** to enter the Set mode.
- ③ Push **[▲]** or **[▼]** to select the weather alert item (ALt).
- ④ Rotate **[VOL]** to select "ON," to turn ON the Weather Alert function.
- ⑤ Push **[# ENT]** to exit the Set mode.
- ⑥ Set the desired stand-by mode.
 - Select the VFO, memory channel or Call channel.
 - **Scan** or **priority watch** operation can be also selected.
- ⑦ When the alert is detected, a beep sounds and "ALt" and the weather channel number is alternately displayed.
- ⑧ Turn OFF the Weather Alert function in the Set mode.

• The "Weather alert" item in the Set mode

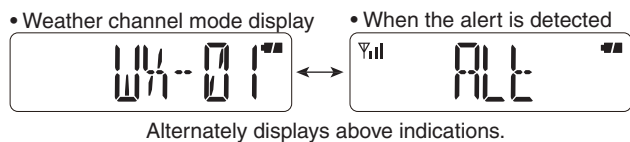
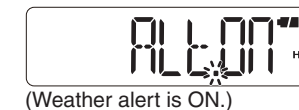

NOTE: While receiving a signal on a frequency other than the weather channel, the receiving audio will be momentarily interrupted approximately every 5 seconds, when the Alert function is turned ON. This is caused by the Weather Alert function. To cancel these interruptions, turn OFF the Weather Alert function in the Set mode.

Push **[FUNC](*)**, and then push **[SCAN](5)** to start a weather channel scan. To stop the scan, push any key except **[▲]/[▼]**, **[FUNC](*)** and **[MONI]**.

■ Accessing a repeater

When using a **repeater**, the transmit frequency is shifted from the receive frequency by the **frequency offset** (p. 38). This is called **duplex** operation. It is convenient to program repeater information into memory channels (p. 21).

① Set the receive frequency (the repeater output frequency).

• **For only USA version of IC-V80:**

When the Auto Repeater function is ON, steps ② and ③ are not necessary.

② Push **[FUNC](*)**, and then push **[DUP](4)** several times to select minus duplex or plus duplex. (“-” or “+”)

③ Push **[FUNC](*)**, and then push **[TONE](1)** several times to turn ON the subaudible tone encoder, depending on the repeater requirements.

• “J” appears.

• The subaudible tone frequency can be set in the Set mode.

④ Hold down **[PTT]** to transmit.

• The displayed frequency automatically changes to the transmit frequency (repeater input frequency).

• If “OFF” appears, confirm that the frequency offset is correctly set.

⑤ Release **[PTT]** to receive.

⑥ Hold down **[MONI]** to check whether you can directly receive the signal from the other station.

• When the other station’s signal can be directly received, move to a non-repeater frequency to use **simplex**. (duplex OFF)

/// **For only USA version of IC-V80:**

Auto Repeater function uses standard repeater tone frequencies and frequency offsets.

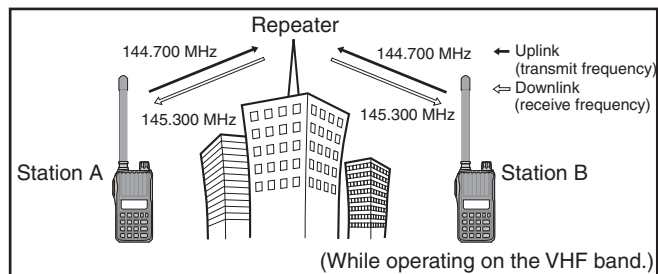

• Setting the shift direction of the transmit frequency

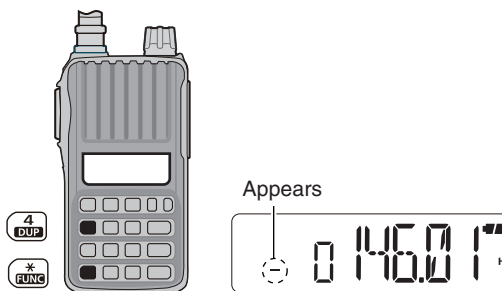

• Turning ON the subaudible tone encoder

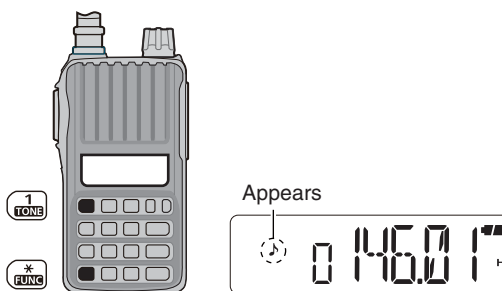

• While receiving



• While transmitting



5 REPEATER AND DUPLEX OPERATIONS

■ Duplex operation

◇ Setting the frequency offset

- ① Push **[FUNC](*)**, and then push **[SET](8)** to enter the Set mode.
- ② Push **[▲]** or **[▼]** to select the **frequency offset** item.
 - “±” and decimal point “.” blink, and the current frequency offset appears.
- ③ Rotate **[VOL]** to set the desired frequency offset.
 - The offset is set in the same step as the frequency tuning step.
 - The unit of the frequency offset is “MHz.”
- ④ Push **[# ENT]** to exit the Set mode.

• The “Offset” item in the Set mode



◇ Setting the duplex direction

- ➔ Push **[FUNC](*)**, and then push **[DUP](4)** to select the offset direction.
- The “-” (negative offset) or “+” (positive offset) icon appears to represent the frequency offset direction.
 - “-” or “+” blinks when the Reversed **Duplex** function is ON.

• Setting the shift direction of the transmit frequency

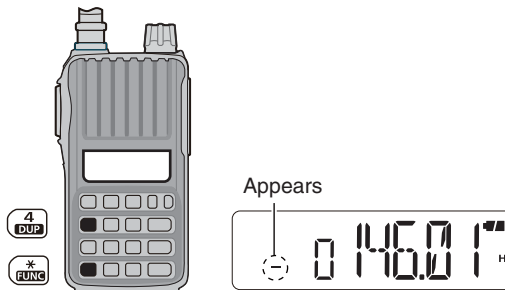

For only USA version of IC-V80:

The Auto Repeater function has priority over the manual duplex setting. If the transmit frequency changes after setting, the Auto Repeater function may have changed the duplex setting. Turn OFF the Auto Repeater function to prevent this.

• Example— When the frequency offset is 0.6 MHz

Duplex	While receiving	While transmitting
+ (positive)	0 145.30 MHz	0 145.90 MHz
- (negative)	0 145.30 MHz	0 144.70 MHz

◇ Reversed Duplex function

When the Reversed Duplex function is ON, the receive and transmit frequencies are reversed.

- ① Push **[FUNC](*)**, and then push **[SET](8)** to enter the Set mode.
- ② Push **[▲]** or **[▼]** to select the Reversed Duplex function item (REV).
- ③ Rotate **[VOL]** to turn the function ON or OFF.
- ④ Push **[# ENT]** to exit the Set mode.
 - “-” or “+” blinks when the Reversed Duplex function is ON.

• “-” or “+” blinks when the Reversed Duplex function is ON.



Each receive and transmit frequency is shown in the table below, with the following configurations:

Input frequency : 145.300 MHz
 Direction : - (negative)
 Offset : 0.6 MHz

Reversed	RX frequency	TX frequency
OFF	145.300 MHz	144.700 MHz
ON	144.700 MHz	145.300 MHz

5 REPEATER AND DUPLEX OPERATIONS

■ Subaudible tones

Some **repeaters** require subaudible tones to access. Subaudible tones are superimposed over your normal signal, and must be set in advance.

- ① Push **[FUNC](*)**, and then push **[SET](8)** to enter the Set mode.
- ② Push **[▲]** or **[▼]** to select the repeater tone item (rt).
- ③ Rotate **[VOL]** to select the desired subaudible tone frequency.
- ④ Push **[# ENT]** to exit the Set mode.

• The “Repeater tone” item in the Set mode



(88.5 Hz is selected)

• **Available subaudible tone frequencies** (unit: Hz)

67.0	79.7	94.8	110.9	131.8	156.7	171.3	186.2	203.5	229.1
69.3	82.5	97.4	114.8	136.5	159.8	173.8	189.9	206.5	233.6
71.9	85.4	100.0	118.8	141.3	162.2	177.3	192.8	210.7	241.8
74.4	88.5	103.5	123.0	146.2	165.5	179.9	196.6	218.1	250.3
77.0	91.5	107.2	127.3	151.4	167.9	183.5	199.5	225.7	254.1

✓ **CONVENIENT!**

Tone scan:

If you don't know the subaudible tone used for a repeater, the tone scan is convenient for detecting the tone frequency.

- ➔ Push **[FUNC](*)**, and then push **[T.SCAN](3)** to start a tone scan.
- See page 32 for details of the Tone Scan function.

◇ 1750 Hz TONE

To access some European repeaters, the transceiver must transmit a 1750 Hz tone burst.

For only IC-V80E

- ➔ Quickly push **[PTT]** once, then immediately hold down **[PTT]** again for 1 or 2 seconds.

For other transceivers

NOTE: First, set the DTMF TX key to “dmt.t” in the Set mode. (p. 34)

- ➔ While holding down **[PTT]**, hold down either the **[▲]** or **[▼]** for 1 or 2 seconds.

■ DTCS encoder (Only TX)

The DTCS encoder superimposes the selected **DTCS** code over your transmitted signal.

- ① Push **[FUNC](*)**, and then push **[SET](8)** to enter the Set mode.
- ② Set the DTCS code and polarity, in the same way you set the DTCS squelch. (p. 30)
 - You can set the DTCS transmit and receive polarity, but the DTCS encoder affects only transmit.
- ③ Push **[# ENT]** to exit the Set mode.
- ④ Push **[FUNC](*)**, and then push **[TONE](1)** several times, until both “Ⓢ” and “Ⓜ” appear.
 - The DTCS encoder activated.

Push **[FUNC](*)**, and then push **[TONE](1)** several times to turn ON the DTCS encoder.



DTCS encoder (Only TX)

5 REPEATER AND DUPLEX OPERATIONS

■ Lockout function

This function helps prevent interference to other stations by inhibiting transmitting when a signal is received. The transceiver has two inhibiting conditions; **repeater** and busy.

- ① Hold down **[⏻]** for 1 second to turn OFF the power.
- ② While holding down **[▲]** and **[▼]**, turn ON the power to enter the Initial Set mode.
- ③ Push **[▲]** or **[▼]** to select the lockout item (RLO).
- ④ Rotate **[VOL]** to select the Lockout function option of "RP," "bU" or "OF."
 - "RLO.OF" : The Lockout function is OFF.
 - "RLO.RP" : The transmit is inhibited when a signal with an un-matched subaudible tone is received.
 - "RLO.bU" : Transmit is inhibited when a signal is received.
- ④ Push **[# ENT]** to exit the Initial Set mode.

- The "Lockout" item in the Initial Set mode



(The Repeater Lockout function is OFF.)



(The Repeater Lockout function is ON.)



(The Busy Lockout function is OFF.)

■ Auto Repeater function

Only USA version of IC-V80

The USA version automatically activates the repeater settings (DUP- or DUP+ and tone encoder ON/OFF), when the operating frequency falls within the general repeater output frequency range. It deactivates them when outside of the range.

- ① Hold down **[⏻]** for 1 second to turn OFF the power.
- ② While holding down **[▲]** and **[▼]**, turn ON the power to enter the Initial Set mode.
- ③ Push **[▲]** or **[▼]** to select the Auto Repeater item (RPt).
- ④ Rotate **[VOL]** to set the Auto Repeater function to "R1," "R2" or "OF."
 - "RPt.OF" : The Auto Repeater function is OFF.
 - "RPt.R1" : The Auto Repeater function is ON (For only **duplex**).
 - "RPt.R2" : The Auto Repeater function is ON (For duplex and tone encoder).
- ⑤ Push **[# ENT]** to exit the Initial Set mode.

- The "Auto repeater" item in the Initial Set mode



Auto Repeater function is OFF.



Auto Repeater function is ON (For only duplex).



Auto Repeater function is ON (For duplex and tone encoder).

• Frequency range and offset direction

Frequency range	Duplex direction
145.200–145.495 MHz 146.610–146.995 MHz	"_" appears.
147.000–147.395 MHz	"+" appears.

General description

The transceiver has 207 memory channels, including 6 scan edge memory channels (3 pairs), and 1 Call channel. These channels can be individually programmed with:

- Operating frequency (p. 13)
- Passband width (p. 13)
- Duplex direction (+ or –) with frequency offset (p. 18)
- Reversed Duplex function ON/OFF (p. 18)
- Subaudible tone encoder (p. 19), tone squelch or DTCS squelch ON/OFF (p. 31)
- Subaudible tone frequency (p. 19), CTCSS tone frequency or DTCS code with polarity (p. 30)
- Skip setting (p. 28)
- Tuning step (p. 13)
- Output power (p. 15)
- TX permission (p. 39)

Programming memory/Call channel

- ① Push **[VFO/MR/CALL]** several times to select the VFO mode.
- ② Set the desired frequency.
 - ➔ If desired, set other data (e.g. frequency offset, duplex direction, tone squelch, and so on.).
- ③ Push **[FUNC](*)**, and then push **[VFO/MR/CALL]**.
 - “MR” and the memory channel number blink.
- ④ Push **[▲]** or **[▼]** to select the memory channel to be programmed.
 - Select 1A/b, 2A,b or 3A/b to program a scan edge channel. (p. 27)
 - Select the Call channel (“C”) to program the Call channel.
- ⑤ Push **[FUNC](*)**, and then hold down **[VFO/MR/CALL]** for 1 second to program.
 - 3 beeps sound.
 - The memory channel number automatically increases, when continuing to hold down **[VFO/MR/CALL]** after programming.

NOTE: To cancel programming, push **[VFO/MR/CALL]** before doing step ⑤.

[i.e.]: programming 145.440 MHz into memory channel 11.

Set the frequency.

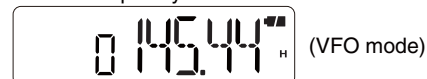

Push **[*] [FUNC]**, and then push **[VFO/MR/CALL]**.



Push **[▲]** or **[▼]** to select channel 11.



Push **[*] [FUNC]**, and then hold down **[VFO/MR/CALL]** for 1 second.



Automatically returns to the VFO mode.

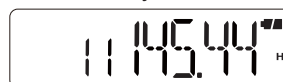

6 MEMORY/CALL OPERATION

■ Selecting a memory channel

◇ Using [▲] or [▼]

- ① Push **[VFO/MR/CALL]** several times to select the memory mode.
 - “MR” appears.
- ② Push [▲] or [▼] to select the desired channel.
 - Only programmed channels are displayed.

◇ Using the keypad

- ① Push **[VFO/MR/CALL]** several times to select the memory mode.
 - “MR” appears.
- ② To select the desired channel, enter the 3 digits of the channel number using the keypad.
 - Blank channels are also selectable.
 - Entering one or two digits, and then pushing **[# ENT]** also selects a 1 or 2 digit memory channel, respectively.

[i.e.]: Selecting memory channel “14.”

Push **[VFO/MR/CALL]**.



Appears



Push **[0]**, **[1]** and **[4]** sequentially.



The memory channel is selected.

■ Selecting the Call channel

- ➔ Push **[VFO/MR/CALL]** several times to select the Call channel mode.
 - “C” appears instead of the memory channel number.

Push **[VFO/MR/CALL]** several times to select the Call channel mode.



Appears

6 MEMORY/CALL OPERATION

■ Copying memory/Call contents

This function copies a memory channel's contents to the VFO, another memory or Call channel. This function is useful when searching for signals around the memory channel frequency, and for easy recalling the **frequency offset**, subaudible tone frequency, and so on.

◇ Memory/Call channel ⇔ VFO

- Push **[VFO/MR/CALL]** several times to select the memory mode or Call channel mode.
 - **For memory channel:**
Push **[▲]** or **[▼]** to select the memory channel to be copied.
- Push **[FUNC](*)**, and then hold down **[VFO/MR/CALL]** for 1 second to copy the selected memory or Call channel contents to the VFO.
 - The VFO mode is automatically selected.

[i.e.]: Copying memory channel 11 contents to the VFO

Push **[▲]** or **[▼]** to select channel 11.



Push **[FUNC](*)**, and then hold down **[VFO/MR/CALL]** for 1 second.

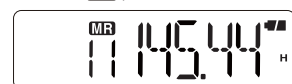

◇ Memory/Call ⇔ memory/Call

- Push **[VFO/MR/CALL]** several times to select the memory mode or Call channel mode.
 - **For memory channel:**
Push **[▲]** or **[▼]** to select the memory channel to copy.
- Push **[FUNC](*)**, and then push **[VFO/MR/CALL]**.
 - "MR" and "--" blink.
 - Do not hold down **[VFO/MR/CALL]** for more than 1 second, otherwise the memory contents will be copied to the VFO mode.
- Push **[▲]** or **[▼]** to select the target memory or Call channel.
- Push **[FUNC](*)**, and then hold down **[VFO/MR/CALL]** for 1 second, to copy the contents of selected memory or Call channel to the target memory.

[i.e.]: Copying memory channel 11 contents to channel 12.

Push **[▲]** or **[▼]** to select channel 11.



Push **[FUNC](*)**, and then push **[VFO/MR/CALL]**.



Push **[▲]** or **[▼]** to select channel 12.

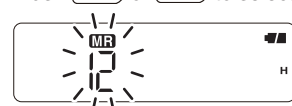

Push **[FUNC](*)**, and then hold down **[VFO/MR/CALL]** for 1 second.



6 MEMORY/CALL OPERATION

■ Clearing memory contents

Contents of programmed memories can be cleared (blanked).

- ① Push **[VFO/MR/CALL]** several times to select the memory or Call channel mode.
 - For only USA version:**
Select any mode other than the weather channel mode.
- ② Push **[FUNC](*)**, and then push **[VFO/MR/CALL]**.
 - “MR” and “-” blink.
- ③ Push **[▲]** or **[▼]** to select the channel to be cleared.
 - Memory channels not yet programmed are blank.
- ④ Perform the following operation **within 1.5 seconds**, otherwise the transceiver returns to the memory mode without clearing memory.
 - ① Push **[FUNC](*)**, and then momentarily push **[VFO/MR/CALL]**.
 - ② Push **[FUNC](*)**, and then hold down **[VFO/MR/CALL]** for 1 second
 - 3 beeps sound, and then the memory channel is cleared.
- ⑤ Push **[VFO/MR/CALL]** to return to the previous mode.

NOTE: Be careful!— the contents of cleared memories CANNOT be recalled.

■ Display type

The transceiver has 3 memory mode display types to suit your operating style. Select the display type in the Initial Set mode. (p. 43)

“Frequency display”

Displays the programmed frequency.

“Channel number display”

Displays the memory channel number. Only programmed channels are displayed, and modes other than the memory mode cannot be selected.

NOTE: When the channel number display is selected, only the memory mode is selectable, and only the following functions can be used.

- Scan function (p. 26)
- Setting output power (p. 15)
- DTMF Memory function (p. 33)
- Key Lock function (p. 15)
- Setting of following items in the Set mode (p. 36)
The scan resume, function key timer, LCD backlight, VOX-related settings, microphone gain and DTMF TX key.

“Channel name display”

Displays the channel name you have assigned. Only programmed channels are displayed.

- If no channel name is programmed, the programmed frequency will be displayed.
- Hold down **[MONI]** to check the programmed frequency.

NOTE: When the display type is “Channel name,” you must select the VFO mode to enter the Set mode.

[i.e.]: Clearing memory channel 11.

Push **[*] [FUNC]**, and then **[VFO/MR /CALL]**.



Push **[▲]** or **[▼]** to select channel 11.



Perform the following operation within 1.5 seconds

Push **[*] [FUNC]**, and then push **[VFO/MR /CALL]**, and push **[*] [FUNC]**, and then hold down **[VFO/MR /CALL]** for 1 second again.



Push **[VFO/MR /CALL]** to return to the previous mode.

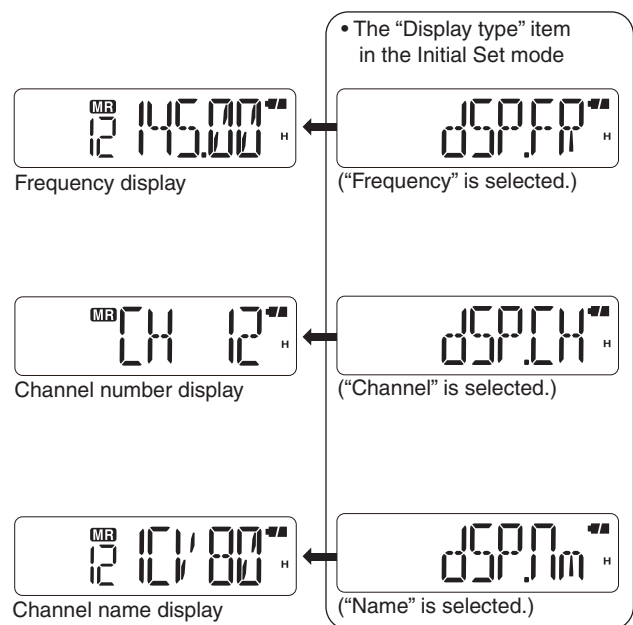

Hold down **[MONI]** to check the programmed frequency.



6 MEMORY/CALL OPERATION

■ Programming channel names

Each memory channel and the Call channel can be programmed with an alphanumeric channel name, for easy recognition. Names can be a maximum of 5 characters.

◇ Setting the display type

- ① Hold down **[⏻]** for 1 second to turn OFF the power.
- ② While holding down **[▲]** and **[▼]**, turn ON the power to enter the Initial Set mode.
- ③ Push **[▲]/[▼]** to select the display type item. (dSP)
- ④ Rotate **[VOL]** to select “dSP.nm.”
- ⑤ Push **[# ENT]** to exit the Initial Set mode.

• The “Display type” item in the Initial Set mode



◇ Programming a channel name

- ① Select the channel name display in the Initial Set mode. (See the above topic.)
- ② Push **[VFO/MR/CALL]** several times to select the memory mode or Call channel mode.
 - For memory channel:
 - Push **[▲]** or **[▼]** to select the desired memory channel.
- ③ Push **[FUNC](*)**, and then push **[SET](8)** to enter the channel name programming mode.
 - A cursor blinks for the first character.
- ④ Rotate **[VOL]** to select a character.
 - The selected character blinks.
- ⑤ Push **[▲]** to move the cursor right, push **[▼]** to move the cursor left.
- ⑥ Repeat steps ④ and ⑤, until the desired channel name is completed.
- ⑦ Push **[# ENT]** to exit the programming mode.

[i.e.]: Programming “CALL” into memory channel 12.

Push **[▲]** or **[▼]** to select channel 12.



Push **[* FUNC]**, and then push **[8 SET]**.



Rotate **[VOL]** to select the character, and then push **[▲]** or **[▼]** to move the cursor.



Repeat until the name is complete.

Push **[# ENT]** to exit the programming mode.



◇ Selectable characters

A	b	C	d	E	F	G	H	I	J	k	L	m
(A)	(b)	(C)	(d)	(E)	(F)	(G)	(H)	(I)	(J)	(k)	(L)	(m)
n	O	P	q	R	S	t	U	V	W	X	y	Z
(n)	(O)	(P)	(q)	(R)	(S)	(t)	(U)	(V)	(W)	(X)	(y)	(Z)
1	2	3	4	5	6	7	8	9	0			
(1)	(2)	(3)	(4)	(5)	(6)	(7)	(8)	(9)	(0)			
+	-	=	*	/	[]	:	(Space)				
(+)	(-)	(=)	(*)	(/)	([)	(])	(:)					

7 SCAN OPERATION

■ Scan types

A scan automatically searches for signals, and makes it easier to locate new stations for contact or listening purposes.

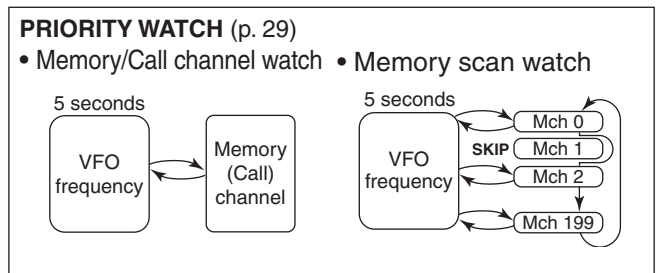
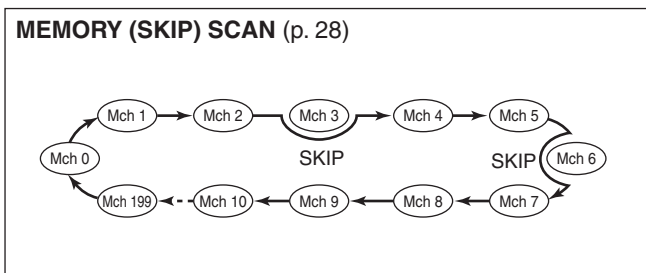
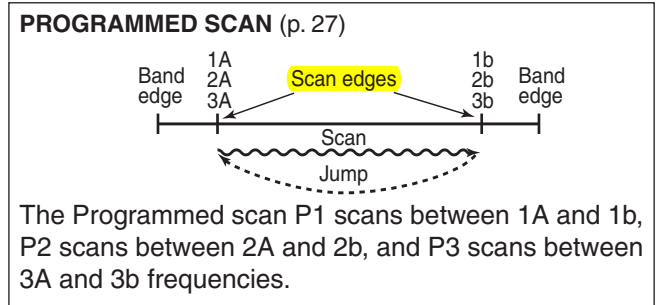
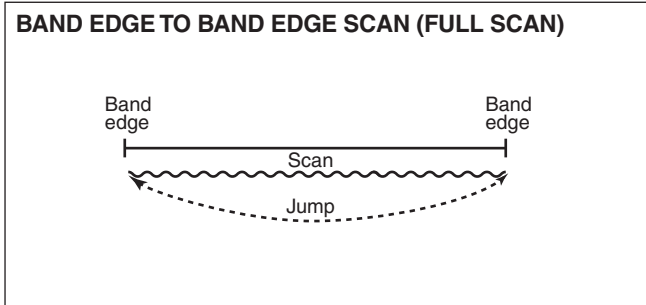

■ Band edge to band edge scan (Full scan)

The band edge to band edge scan repeatedly scans through the operating band.

- ① Push **[VFO/MR/CALL]** several times to select the VFO mode.
- ② Push **[FUNC](*)**, and then push **[SCAN](5)** to start the scan.
- ③ During the scan, push **[FUNC](*)**, and then push **[SET](8)** several times to select "AL" (band edge to band edge scan), if necessary.
 - To change the scan direction, push **[▲]** or **[▼]**.
- ④ To cancel the scan, push any key except **[⏻]**, **[▲]/[▼]**, **[MONI]** or **[FUNC](*)**.

[i.e.]: Starting the band edge to band edge scan.

Push **[VFO/MR/CALL]** several times.



Push **[FUNC](*)**, and then push **[SCAN](5)**. (A scan starts)

If necessary, push **[FUNC](*)**, and then push **[SET](8)** several times to select the scan type "AL."

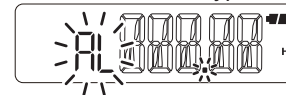

7 SCAN OPERATION

■ Programmed scan

Repeatedly scans between two programmed frequencies (memory channels “xA” and “xb”). Used to check for frequencies within a specified range, such as **repeater** output frequencies, and so on. 3 pairs of **scan edges** are programmable.

Scan edge channels, 1A/b, 2A,b and 3A/b must be programmed in advance.

◇ Programming scan edge channels

- ① Push **[VFO/MR/CALL]** several times to select the VFO mode.
- ② Set the desired frequency.
- ③ Push **[FUNC](*)**, and then push **[VFO/MR/CALL]**.
 - “MR” and the memory channel number blink.
- ④ Push **[▲]** or **[▼]** to select a scan edge channel (“xA”).
- ⑤ Push **[FUNC](*)**, and then hold down **[VFO/MR/CALL]** for 1 second to save the entry.
 - 3 beeps sound.
- ⑥ In same way, program another scan edge channel (“xb”).

NOTE: To cancel programming, push **[VFO/MR/CALL]** before storing the entry in step ⑤.

◇ Starting a programmed scan

- ① Push **[VFO/MR/CALL]** several times to select the VFO mode.
- ② Push **[FUNC](*)**, and then push **[SCAN](5)** to start the scan.
- ③ During the scan, push **[FUNC](*)**, and then push **[SET](8)** several times to select either the “P1,” “P2” or “P3” scan.
 - “P1,” “P2” and “P3” for programmed scan between the programmed **scan edge** channels.
 - To change the scan direction, push **[▲]** or **[▼]**.
- ④ To cancel the scan, push any key except **[PWR]**, **[▲]**/**[▼]**, **[MONI]** or **[FUNC](*)**.

NOTE: Scan edge channels, 1A/b, 2A/b and 3A/b must be programmed in advance. Program them in the same manner as regular memory channels. If identical frequencies are programmed into the scan edge channels, the programmed scan will not function.

[i.e.]: Programming 145.300 MHz into scan edge 1A.

Set the frequency.

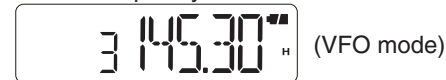

Push **[* FUNC]**, and then push **[VFO/MR /CALL]**.



Push **[▲]** or **[▼]** to select channel 1A.



Push **[* FUNC]**, and then hold down **[VFO/MR /CALL]** for 1 second.

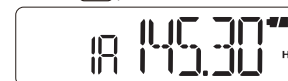

Automatically returns to the VFO mode.

[i.e.]: Starting a scan between edge channels 1A and 1b.

Push **[* FUNC]**, and then push **[5 SCAN]**. (A scan starts)



If necessary, push **[* FUNC]**, and then push **[8 SET]** several times to select the scan type “P1.”

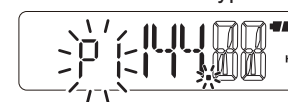

7 SCAN OPERATION

Memory Scan

Repeatedly scans memory channels, except those set as skip channels, described in the next scan topic.

- ① Push **[VFO/MR/CALL]** several times to select the memory mode.
 - “MR” appears.
- ② Push **[FUNC](*)**, and then push **[SCAN](5)** to start the scan.
 - To change the scan direction, push **[▲]** or **[▼]**.
- ③ To cancel the scan, push any key except **[⏻]**, **[▲]**/**[▼]**, **[MONI]** or **[FUNC](*)**.

Push **[VFO/MR/CALL]** several times to select the memory mode.



Push **[FUNC](*)**, and then push **[SCAN](5)**. (The memory scan starts.)

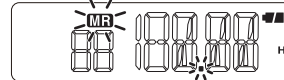

Setting skip channels

The Memory Skip function speeds up scanning by not scanning those memory channels set as skip channels. Set skip channels as follows.

- ① Push **[VFO/MR/CALL]** several times to select the memory mode.
- ② Push **[▲]** or **[▼]** to select the memory channel to be skipped.
- ③ Push **[FUNC](*)**, and then push **[SKIP](6)** to set the channel as a skip channel.
 - “SKIP” appears.

[i.e.]: Setting memory channel 11 as the skip channel.

Push **[▲]** or **[▼]** to select channel 11.



Push **[FUNC](*)**, and push **[SKIP](6)**.



Appears

Scan resume setting

Various pause and timer options can be selected with the Scan Resume function. The selected resume option is also used for **Priority Watch**.

- ① Push **[FUNC](*)**, and then push **[SET](8)** to enter the Set mode.
- ② Push **[▲]** or **[▼]** to select the scan pause timer item (SCt, or SCP).
- ③ Rotate **[VOL]** to select the desired scan resume option.
 - “SCt. 5/10/15” : Timer scan
The scan pauses for 5 to 15 seconds, when a signal is received.
 - “SCP. 2” : Pause scan
The scan pauses, then resumes 2 seconds after the signal disappears.
- ④ Push **[# ENT]** to exit the Set mode.

• The “Scan pause timer” item in the Set mode



(Pause scan is selected.)



(Timer scan (15 seconds) is selected.)

7 SCAN OPERATION

Priority watch

A priority watch checks for signals on “priority channel/s” while operating on a VFO frequency.

Memory or Call channel watch

While operating on a VFO frequency, Priority Watch checks for a signal on the selected memory or Call channel (priority channel) every 5 seconds.

- ① Select the VFO mode, and then set the operating frequency.
- ② Push **[VFO/MR/CALL]** several times to select the memory mode or Call channel mode.
 - **For memory channel watch:**
Push **[▲]** or **[▼]** to select the desired memory channel.
- ③ Push **[FUNC](*)**, and then push **[PRIO](7)** to start the watch.
 - The decimal point “.”, on the frequency readout blinks.
 - When a signal is received on the priority channel, the watch resumes according to the selected scan resume option (p. 28).
- ④ To cancel the watch, push any key except **[⏻]**, **[▲]**/**[▼]**, **[MONI]**, **[FUNC](*)**, or **[PTT]**.

Memory scan watch

While operating on a VFO frequency, Priority Watch sequentially checks for signals on each memory (except Skip) channel (priority channel).

- ① Select the VFO mode, and then set the operating frequency.
- ② Push **[VFO/MR/CALL]** several times to select the memory mode.
- ③ Push **[FUNC](*)**, and then push **[SCAN](5)** to start the memory scan.
- ④ Push **[FUNC](*)**, and then push **[PRIO](7)** to start the watch.
 - The VFO mode is automatically selected, and the decimal point “.”, on the frequency readout blinks.
 - When a signal is received on a channel, the watch resumes according to the selected scan resume option (p. 28).
- ⑤ To cancel the watch, push any key except **[⏻]**, **[▲]**/**[▼]**, **[MONI]**, **[FUNC](*)**, or **[PTT]**.

[i.e.]: The memory channel watch on memory channel 10.

Set the operating frequency.



Push **[VFO/MR/CALL]** to select the memory mode.



Push **[▲]** or **[▼]** to select the desired memory channel (priority channel)



Push **[FUNC](*)**, and then push **[7 PRIO]**. (The watch starts.)



The watch checks for a signal on memory channel 10, every 5 seconds.

[i.e.]: The memory scan watch.

Set the operating frequency.



Push **[VFO/MR/CALL]** to select the memory mode.



Push **[FUNC](*)**, and then push **[5 SCAN]**. (The memory scan starts.)

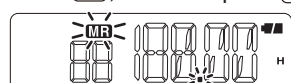

Push **[FUNC](*)**, and then push **[7 PRIO]**.

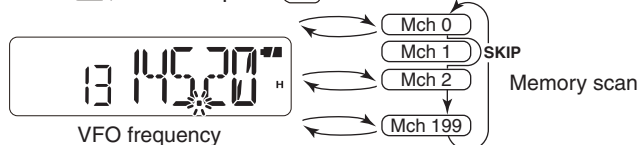

The watch checks for a signal on each memory channel, every 5 seconds.

8

TONE SQUELCH AND POCKET BEEP

■ Tone/DTCS squelch

◇ Tone squelch and DTCS squelch

The tone squelch or **DTCS** squelch opens when a signal with the same pre-programmed subaudible tone or DTCS code is received.

• Recommended CTCSS tones (unit: Hz)

67.0	79.7	94.8	110.9	131.8	156.7	186.2	225.7
69.3	82.5	97.4	114.8	136.5	162.2	192.8	233.6
71.9	85.4	100.0	118.8	141.3	167.9	203.5	241.8
74.4	88.5	103.5	123.0	146.2	173.8	210.7	250.3
77.0	91.5	107.2	127.3	151.4	179.9	218.1	

• Recommended DTCS code

023	051	114	143	174	251	315	371	445	532	631	723
025	054	115	152	205	261	331	411	464	546	632	731
026	065	116	155	223	263	343	412	465	565	654	732
031	071	125	156	226	265	346	413	466	606	662	734
032	072	131	162	243	271	351	423	503	612	664	743
043	073	132	165	244	306	364	431	506	624	703	754
047	074	134	172	245	311	365	432	516	627	712	

◇ Setting tone frequency or DTCS code

- 1 Push **[FUNC](*)**, and then push **[SET](8)** to enter the Set mode.
- 2 Push **[▲]** or **[▼]** to select the tone frequency item (Ct) or the DTCS code item (dt).
 - "ct" blinks when selecting the **CTCSS** tone item, and "dt" blinks when selecting the DTCS code item.
- 3 Rotate **[VOL]** to set the desired tone frequency, or DTCS code.
- 4 Push **[# ENT]** to exit the Set mode.

- The "CTCSS tone" item in the Set mode



CTCSS tone setting (88.5 Hz is selected.)

- The "DTCS code" item in the Set mode



DTCS code setting (023 is selected.)

◇ Setting DTCS polarity

For DTCS operation, the polarity setting is also configurable, as well as the code setting. If the polarity is different, the DTCS squelch never opens, even when receiving a signal that includes a matching DTCS code.

- 1 Push **[FUNC](*)**, and then push **[SET](8)** to enter the Set mode.
- 2 Push **[▲]** or **[▼]** to select the DTCS polarity item (dtP).
- 3 Rotate **[VOL]** to select the desired polarity.
 - "dtP.nn" : Normal
 - "dtP.nR" : Normal for TX, reverse for RX
 - "dtP.Rn" : Reverse for TX, normal for RX
 - "dtP.RR" : Reverse
- 4 Push **[# ENT]** to exit the Set mode.

- The "DTCS polarity" item in the Set mode



TX and RX: Normal polarity



TX: Normal, RX: Reverse



TX: Reverse, RX: Normal



TX and RX: Reverse polarity

8 TONE SQUELCH AND POCKET BEEP

◇ Operation

- ① Set the operating frequency, or select a memory channel or Call channel.
- ② Push **[FUNC](*)**, and then push **[SET](8)** to enter the Set mode.
- ③ Set the tone frequency, or **DTCS** code and DTCS polarity.
- ④ Push **[# ENT]** to exit the Set mode.
- ⑤ Push **[FUNC](*)**, and then push **[TONE](1)** several times, until the icon of desired Tone function appears.
 - “**q**” : **CTCSS** squelch
 - “**@**” : **DTCS** squelch
- ⑥ Operate the transceiver in a normal way; push **[PTT]** to transmit, release **[PTT]** to receive.
- ⑦ When a signal with matched tone or code is received, the squelch opens and audio is heard.
 - To manually open the squelch, push **[MONI]**.
 - If the signal includes an unmatched tone, the squelch does not open. However, the icon shows the strength of the received signal.
- ⑧ To cancel the tone or DTCS squelch, push **[FUNC](*)**, and then push **[TONE](1)** several times, until the tone icon disappears.

✓ CONVENIENT!

Squelch burst:

While using the tone squelch, noise may be heard just when the received signal disappears.

To eliminate the noise, the IC-U80/IC-U80E has the Squelch Burst function.

See page 44 for details.

■ Pocket Beep function

This function uses subaudible tones for calling, and can be used as a “common pager” to inform you that someone has called while you were away from the transceiver.

- ① Set the operating frequency, or select the memory channel or Call channel.
- ② Push **[FUNC](*)**, and then push **[SET](8)** to enter the Set mode.
- ③ Set the tone frequency, or DTCS code and DTCS polarity.
- ④ Push **[# ENT]** to exit the Set mode.
- ⑤ Push **[FUNC](*)**, and then push **[TONE](1)** several times, until the icon of desired Tone function and “**!**” appear.
 - “**!**” and “**q**” : CTCSS **Pocket Beep function**
 - “**!**” and “**@**” : DTCS **Pocket Beep function**
- ⑥ When a signal with matched tone or code is received, beep tones sound and “**!**” blinks.
 - To stop the beeps and blinking, push any key.
- ⑦ To cancel the tone or DTCS squelch, push **[FUNC](*)**, and then push **[TONE](1)** several times, until the tone icon disappears.

Push **[* FUNC]**, and then push **[1 TONE]** to sequentially select the tone function.

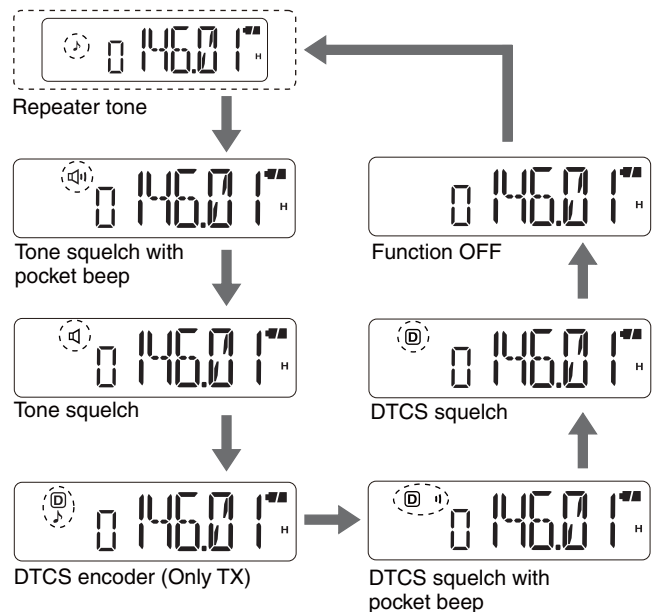

Push **[* FUNC]**, and then push **[1 TONE]** several times to turn ON the Pocket Beep function.

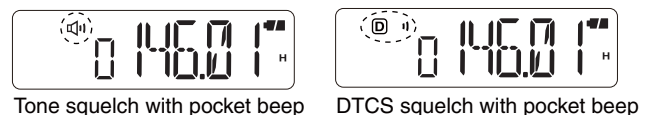

8 TONE SQUELCH AND POCKET BEEP

■ Tone scan

By monitoring a signal that is being operated with the **pocket beep**, tone or **DTCS** Squelch function turned ON, you can determine the tone frequency or DTCS code necessary to open the squelch.

- ① Set a frequency or select a memory channel to check for a tone frequency or DTCS code.
- ② Push **[FUNC](*)**, and then push **[TONE](1)** several times, until the icon of desired Tone function is displayed.
 - For a **CTCSS** tone **scan**:
The scan starts without selecting a tone function.
- ③ Push **[FUNC](*)**, and then push **[T.SCAN](3)** to start the tone scan.
 - To change the scan direction, push **[▲]** or **[▼]**.
- ④ When the CTCSS tone frequency or DTCS code is detected, the squelch opens and the detected tone frequency is temporarily programmed into the selected mode.
 - The detected CTCSS tone frequency or DTCS code is used for the tone encoder or decoder, according to the tone condition or type selected in step ②.
 - No icon : Cannot be used for the operation.
 - “J” : Repeater tone encoder
 - “J”+“@” : DTCS encoder (Only TX)
 - “L” : CTCSS tone encoder or decoder
 - “@” : DTCS code encoder or decoder
- ⑤ To cancel the scan, push any key except **[PWR]**, **[▲]**/**[▼]**, **[MONI]** or **[FUNC](*)**.

[i.e.]: A DTCS code scan on 145.20 MHz.

Set the operating frequency.

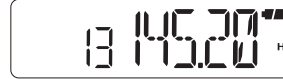

Push **[FUNC](*)**, and then push **[TONE](1)** several times to select the DTCS squelch function.



Appears

Push **[FUNC](*)**, and then push **[T.SCAN](3)**.

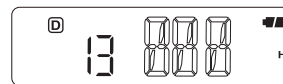

During the DTCS code scan.

9

DTMF MEMORY

■ Programming a DTMF code sequence

DTMF codes are used for autopatching, controlling other equipment, and so on. The transceiver has up to 16 DTMF memory channels (d0–dF) for up to 24 digits often-used DTMF codes.

- ① Push **[FUNC](*)**, and then push **[DTMF-M](0)** to enter the DTMF memory mode.
- ② Push **[▲]** or **[▼]** to select the desired blank DTMF memory channel.
 - The selected DTMF memory channel blinks.
 - If programmed, the previously programmed DTMF code is displayed.
- ③ **NOTE:** Previously programmed code sequence in the selected DTMF memory channel will be cleared by following operation.
 Push **[FUNC](*)**, and then hold down **[DTMF-M](0)** for 1 second to enter the DTMF memory programming mode.
 - “_____” appears.
- ④ Push a key to input the desired DTMF code.
 - Refer to the illustration below for the DTMF code assignment.
 - If a digit is mistakenly input, push **[PTT]** momentarily, and then repeat from step ③.
- ⑤ Repeat step ④, until the desired DTMF code sequence (up to 24 digits) is complete.
 - When the 6th character is set, the icon displays the next blank digit group.
- ⑥ Push **[PTT]** to save the channel and exit the DTMF memory programming mode.
 - After the 24th digit is input, the transceiver automatically saves the code sequence and returns to the DTMF memory mode (step ②).
- ⑦ Push **[VFO/MR/CALL]** to exit the DTMF memory mode.

• DTMF code assignment

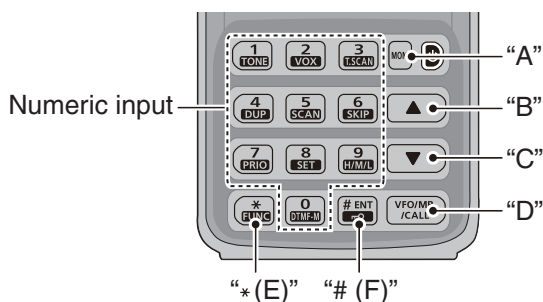

• Programming mode indication

The programming mode consists of 5 groups.

Group	Digits	Icon
1st	1st to 5th	No icon.
2nd	6th to 10th	“i” appears.
3rd	11th to 15th	“ii” appears.
4th	16th to 20th	“iii” appears.
5th	21st to 24th	“iiii” blinks.

[i.e.]: Programming “123456” into the DTMF memory channel “d3.”

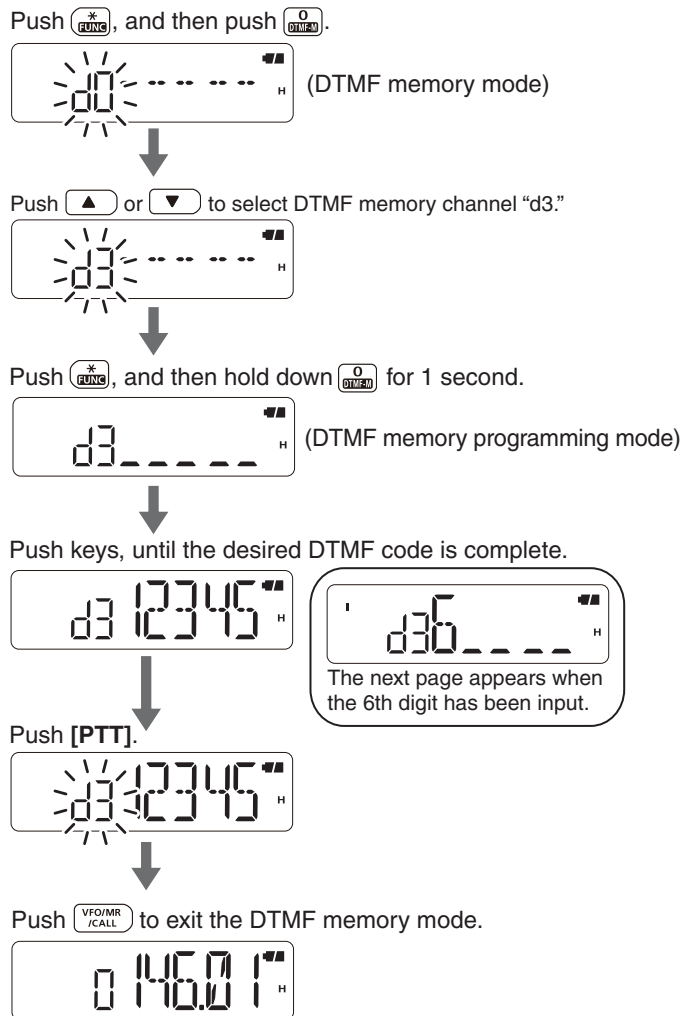

9 DTMF MEMORY

■ Transmitting a DTMF code

The transceiver has three methods of transmitting a **DTMF** code sequence. Select the desired option in the Set mode.

◇ Selecting the DTMF code transmission option

- ① Push **[FUNC](*)**, and then push **[SET](8)** to enter the Set mode.
- ② Push **[▲]** or **[▼]** to select the DTMF TX key item (dmt).
- ③ Rotate **[VOL]** to select the desired option.
 - “dmt.k” : Manual transmission
Transmits the appropriate DTMF code assigned to the key.
 - “dmt.m” : Using DTMF memory
Transmits the programmed DTMF code sequence in the DTMF memory channel assigned to the key.
 - “dmt.t” : Only 1750 Hz tone burst
No DTMF code can be transmitted.
However, while holding down **[PTT]**, pushing either **[▲]** or **[▼]** transmits the 1750 Hz tone burst.
- ④ Push **[# ENT]** to exit the Set mode.

- The “DTMF TX key” item in the Set mode



Manual transmission



Using DTMF memory



Only 1750 Hz tone burst

◇ Manual DTMF code transmission

First, set the DTMF TX key to “dmt.k” in the Set mode.

- While holding down **[PTT]**, push the desired keys to manually transmit a DTMF code sequence.

• DTMF code assignment

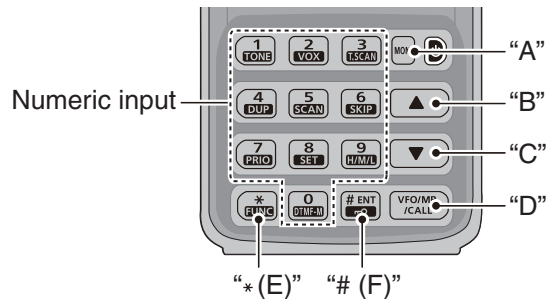

◇ Using a DTMF memory channel

First, set the DTMF TX key to “dmt.m” in the Set mode.

- While holding down **[PTT]**, push the desired DTMF channel number.

• DTMF memory channel number assignment

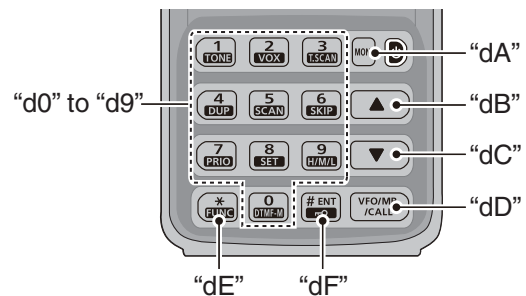

9 DTMF MEMORY

■ Monitoring a DTMF memory

You can monitor the programmed **DTMF** code sequence.

- ① Push **[FUNC](*)**, and then push **[DTMF-M](0)** to enter the DTMF memory mode.
- ② Push **[▲]** or **[▼]** to select the desired DTMF memory channel.
- ③ Push **[MONI]** to monitor the DTMF memory contents.
 - The programmed DTMF code sequence sounds, and then the transceiver automatically exits the DTMF memory mode.

[i.e.]: Monitoring DTMF memory channel “d3.”

Push **[*]**, and then push **[0]**.



Push **[▲]** or **[▼]** to select DTMF memory channel “d3.”



Push **[MONI]**.



The DTMF code sequence sounds.

■ Setting DTMF transfer speed

The transmitting speed of DTMF code can be set to accommodate your operating needs.

- ① Hold down **[P]** for 1 second to turn OFF the power.
- ② While holding down **[▲]** and **[▼]**, hold down **[P]** for 1 second, to turn ON the power to enter the Initial Set mode.
- ③ Push **[▲]** or **[▼]** to select the DTMF TX speed item (dtd).
- ④ Rotate **[VOL]** to select the desired transmitting speed, as shown below.
 - “dtd. 1” : 100 milliseconds interval; 5.0 cps rate
 - “dtd. 2” : 200 milliseconds interval; 2.5 cps rate
 - “dtd. 3” : 300 milliseconds interval; 1.6 cps rate
 - “dtd. 5” : 500 milliseconds interval; 1.0 cps rate

(cps=characters per second)
- ⑤ Push **[# ENT]** to exit the Initial Set mode.

- The “DTMF TX speed” item in the Initial Set mode



(“3” is selected.)

10 SET MODES

■ Set mode programming

The Set mode is used to change the settings of the transceiver's functions.









NOTE: When the display type is "Channel name," you must select the VFO mode to enter the Set mode.

◇ Set mode operation

- ① Push **[FUNC](*)**, and then push **[SET](8)** to enter the Set mode.
- ② Push **[▲]** or **[▼]** to select the desired item.
- ③ Rotate **[VOL]** to select an option or value.
- ④ Push **[# ENT]** to exit the Set mode.

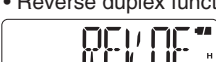
Set mode items

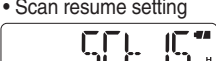
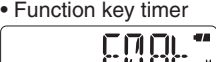
↓: ▲
↑: ▼

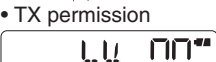
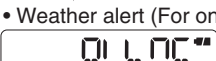
- Repeater tone frequency
 Select the subaudible tone needed to access the repeater. p. 38
- Tone squelch frequency
 Select the CTCSS tone frequency for tone squelch. p. 38
- DTCS code
 Set the DTCS code for DTCS squelch and DTCS encoder. p. 38
- DTCS polarity
 Set the Transmit and Receive DTCS polarity. p. 38
- Frequency offset
 Set the duplex frequency offset. p. 38
- Reverse duplex function
 Turn the Reverse Duplex function ON or OFF. p. 38
- Tuning step
 Select the VFO tuning step. p. 38
- Scan resume setting
 Select the scan pause and resume setting. p. 38
- Function key timer
 Set the time between when the Function mode is entered, and how long it remains activated after you push the keypad key to activate its second function. p. 38
- LCD backlight
 Select the LCD Backlight function. p. 39
- TX permission
 Turns the TX Inhibit function ON or OFF. p. 39
- Weather alert (For only USA version of IC-V80)
 Turn the Weather Alert function ON or OFF. p. 39

NOTE: When the display type setting is set to "CH" in the Initial Set mode, and accessing the Set mode from the memory mode, most of the Set mode items do not appear.

10 SET MODES

■ Set mode programming (continued)

↓ : ▲
 ↑ : ▼

- VOX gain

VOX05

Set the VOX gain.
 To turn OFF the VOX function, select "VOX.OF" p. 39

↓↑
- Microphone gain

MIC2

Set the microphone sensitivity. p. 39

↓↑
- VOX delay

VXD.10

Set the VOX Delay. p. 39

↓↑
- VOX time-out timer

VTO03

Set the VOX time-out timer.
 To turn OFF the function, select "Vto.OF" p. 39

↓↑
- DTMF TX key

dnt.h

Select the method to transmit
 a DTMF code sequence. p. 39

↓↑
- Passband width

W/N.W

Set the operating mode to FM or FM-N. p. 39

NOTE: When the display type setting is set to "CH" in the Initial Set mode, and accessing the Set mode from the memory mode, most of the Set mode items do not appear.

10 SET MODES

■ Set mode items

◇ Repeater tone frequency

Select the subaudible tone needed to access the **repeater**. A total of 50 tone frequencies (67.0–254.1 Hz) are selectable. (default: 88.5 Hz)

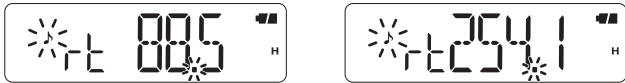

◇ Tone squelch frequency

Select the **CTCSS** tone frequency to use for the Tone Squelch function. A total of 50 tone frequencies (67.0–254.1 Hz) are selectable. (default: 88.5 Hz)

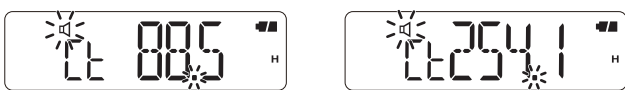

• Usable subaudible tone frequencies (unit: Hz)

67.0	79.7	94.8	110.9	131.8	156.7	171.3	186.2	203.5	229.1
69.3	82.5	97.4	114.8	136.5	159.8	173.8	189.9	206.5	233.6
71.9	85.4	100.0	118.8	141.3	162.2	177.3	192.8	210.7	241.8
74.4	88.5	103.5	123.0	146.2	165.5	179.9	196.6	218.1	250.3
77.0	91.5	107.2	127.3	151.4	167.9	183.5	199.5	225.7	254.1

The transceiver has 50 tone frequencies and consequently their spacing is narrow compared with units having 38 tones. Therefore, some tone frequencies may receive interference from adjacent tone frequencies.

◇ DTCS Code

Set the **DTCS** code (both encoder and decoder) for DTCS squelch operation. A total of 104 codes are selectable. (default: 023)



• Available DTCS codes

023	054	125	165	245	274	356	445	506	627	732
025	065	131	172	246	306	364	446	516	631	734
026	071	132	174	251	311	365	452	523	632	743
031	072	134	205	252	315	371	454	526	654	754
032	073	143	212	255	325	411	455	532	662	
036	074	145	223	261	331	412	462	546	664	
043	114	152	225	263	332	413	464	565	703	
047	115	155	226	265	343	423	465	606	712	
051	116	156	243	266	346	431	466	612	723	
053	122	162	244	271	351	432	503	624	731	

◇ DTCS Polarity

Set the Transmit and Receive DTCS polarity to “NN,” “NR,” “RN” or “RR.”

The polarity for transmitting or receiving can be independently set. (default: dtP.nn)



TX/RX: Normal polarity

TX/RX: Reverse polarity

◇ Frequency offset

Set the **duplex frequency offset** between 0 and 20 MHz. In the duplex mode, the transmit frequency shifts up or down from the receive frequency by the offset amount. (default: Depending on the transceiver versions)

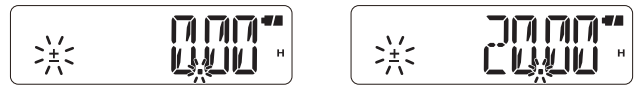

◇ Reversed Duplex function

Turn the Reversed Duplex function ON or OFF (default). When the Reversed Duplex function is ON, the receive and transmit frequencies are reversed. (default: OFF)

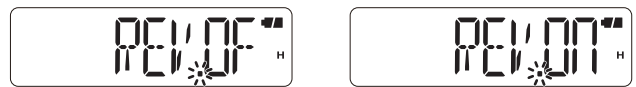

◇ Tuning step

Set the VFO tuning step to 5, 10, 12.5, 15, 20, 25, 30 or 50 kHz. (default: differs depending on the version)

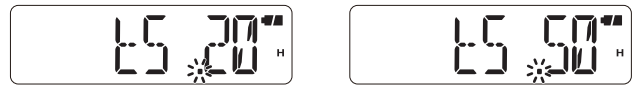

◇ Scan resume setting

Select the scan resume option from Sct. 5, Sct. 10, Sct. 15, or SCP. 2.

- Sct. 5/10/15 : The scan pauses for 5 to 15 seconds, when a signal is received. (default: Sct. 15)
- SCP.2 : The scan pauses, then resumes 2 seconds after the signal disappears.



◇ Function key timer

Push [FUNC](*) to enter the Function mode, and then push a keypad key to activate its second function.

- While in the Function mode, “F” is displayed on the LCD.

Set the time between when the Function mode is entered, and how long it remains activated after you push the keypad key to activate its second function.

- F0.At : Exits the Function mode immediately after a key is pushed to activate its second function. (default)
- F1/2/3.At : The Function mode remains activated 1, 2 or 3 seconds after a key is pushed to activate its second function.
- F.m : The Function mode remains activated until [FUNC](*) is pushed again, even after a key is pushed to activate its second function.



10 SET MODES

◇ LCD backlight

Select the LCD Backlight function.

- LIG.OF : Turns the backlight function OFF.
- LIG.ON : Lights continuously while the transceiver is ON.
- LIG.At : Turns ON when an operation occurs, and turns OFF after 5 seconds. (default)



◇ TX permission

Select "OFF" to inhibit transmitting on the channel.

- tX .OF : Transmit is inhibited. (Receive only)
- tX .ON : Transmit is permitted. (default)



◇ Weather alert *Only USA version of IC-V80*

Turn the Weather Alert function ON or OFF. (p. 16)
(default: OFF)



◇ VOX gain

Set the VOX gain to between 1 and 10. Higher values make the VOX function more sensitive to your voice.

To turn OFF the VOX function, select "VOX.OF."
(default: VOX.05)



NOTE: Set the microphone gain before setting the VOX gain. See page 47 for details of the VOX function.

◇ Microphone gain

Set the microphone gain to between 1 and 4, to suit your preference. Higher values makes the microphone more sensitive to your voice. (default: mic.2)

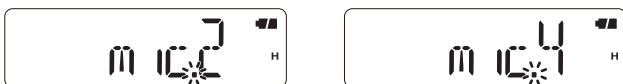

NOTE: When using the VOX function, we recommend setting the microphone gain to 3. However, you can adjust it to suit your operating environment (including your headset performance).

◇ VOX delay

The VOX Delay is the amount of time the transmitter stays ON after you stop speaking.

- VXd.05 : 0.5 seconds delay
- VXd.10 : 1 second delay (default)
- VXd.15 : 1.5 seconds delay
- VXd.20 : 2 seconds delay
- VXd.25 : 2.5 seconds delay
- VXd.30 : 3 seconds delay



◇ VOX time-out timer

Set the VOX time-out timer to between 1, 2, 3 (default), 4, 5, 10 and 15 minutes, to prevent accidental prolonged transmission by the VOX function.

To turn OFF the function, select "Vto.OF"

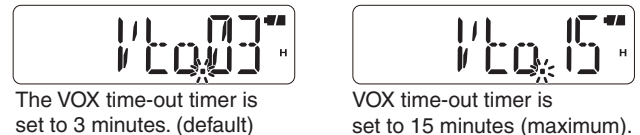

The VOX time-out timer is set to 3 minutes. (default)

VOX time-out timer is set to 15 minutes (maximum).

NOTE: The VOX time-out timer must be set shorter than the time-out timer, otherwise this timer will not function.

◇ DTMF TX key

Selects the method to transmit a DTMF code sequence.

- dmt.k : Transmits the appropriate DTMF code assigned to the key. (p. 34) (default)
- dmt.m : Transmits the programmed DTMF code sequence in the DTMF memory channel assigned to the key.
- dmt.t : No DTMF code can be transmitted. (p. 34)
However, while holding down [PTT], pushing either [▲] or [▼] transmits the 1750 Hz tone burst. (p. 19)



◇ Passband width

Set both the transmission and reception passband width to wide or narrow. (default: W/n. W)

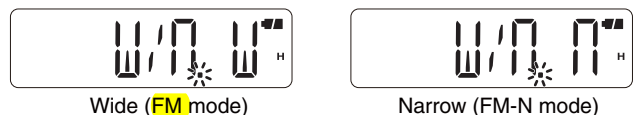

Wide (FM mode)

Narrow (FM-N mode)

10 SET MODES

■ Initial Set mode programming

The initial Set mode can be accessed at power ON, and allows you to set seldom-changed settings. In this way, you can “customize” the transceiver to suit your preference and operating style.

◇ Initial Set mode operation

- ① While holding down **[▲]** and **[▼]**, hold down **[⏻]** for 1 second to enter the Initial Set mode.
- ② Push **[▲]** or **[▼]** to select the desired item.
- ③ Rotate **[VOL]** to select an option or value.
- ④ Push **[# ENT]** to exit the initial Set mode.

Initial Set mode items

↓: **[▲]**
 ↑: **[▼]**

- Key-touch beep

bcp. 2"

Turns the key-touch beep ON (Set the beep level 1 to 3) or OFF. p. 42

↓↑
- Time-out timer

t.o.t. 5"

Inhibit continuous transmissions longer than the selected time period. p. 42

↓↑
- Auto repeater (For only USA version of IC-V80)

± rpr. 1"

Turns the Auto Repeater function ON or OFF. p. 42

↓↑
- Auto power OFF

p.o.f. 0"

Automatically turns OFF the transceiver's power. p. 42

↓↑
- Lockout

p.l.o.c.k

Turn the Lockout function ON or OFF. p. 42

↓↑
- Squelch delay

sqd. 5"

Set the squelch delay to Short or Long. p. 42

↓↑
- DTMF speed

d.t.m.f. 1"

Set the DTMF sending rate. p. 42

↓↑
- Dial assignment

l.o.p./0"

Select whether or not to use [VOL] as the tuning control instead of [▲] and [▼]. p. 43

↓↑
- Display type

d.s.p.f.f.

Select the display type for memory mode operation. p. 43

↓↑
- LCD contrast

l.c.d.c.o.n.t.r.a.s.t.

Select the LCD contrast. p. 43

↓↑
- Power save

p.s.r. 50%

Select the ratio of the power save time to the standby time. p. 43

↓↑
- Dial acceleration

s.s.a.c. 0"

Selects whether or not to accelerate the step speed when rotating [VOL] rapidly. p. 43

↓↑

10 SET MODES

■ Initial Set mode programming (continued)

↓: ▲
 ↑: ▼

- ↓↑
 • Microphone simple mode

mS.MI

Select the Microphone mode. p. 43
- ↓↑
 • Voltage display (For only IC-U80/IC-U80E) p. 44

VLE.ON

Turns the Voltage Display function ON or OFF.
- ↓↑
 • Battery protection

BATE.M

Select the protection option according to your battery type. p. 44
- ↓↑
 • Auto low power

ALP.OF

Turns the Auto Low Power function ON or OFF. p. 44
- ↓↑
 • Squelch burst (For only IC-U80/IC-U80E)

SQB.OF

Turns the Squelch Burst function ON or OFF. p. 44

10 SET MODES

Initial Set mode items

◇ Key-touch beep

Turn the confirmation beeps ON (default) or OFF.

- When changing the beep level, beeps sound at the level. (default: bEP.2)



◇ Time-out timer

To prevent accidental prolonged transmission, the transceiver has a time-out timer. The function inhibits continuous transmissions longer than the set time period (1–30 minutes). (default: tot.5)

- tot.OF : Turns OFF the function.
- tot.1–30 : The transmission is cut OFF after the set time period ends.



Approximately 10 seconds before the time-out timer is activated, the transceiver emits a beep tone as a warning.

Be careful! When using the BP-263 battery case, the batteries will become hot if this Time-out Timer function is turned OFF or set to a long time period, and transmission is made for long periods.

◇ Auto Repeater Only USA version of IC-V80

The Auto Repeater function automatically turns the duplex setting and tone encoder ON or OFF when the operating frequency falls within or outside of the general repeater output frequency range (145.200–145.495 MHz, 146.610–146.995 MHz and 147.000–147.395 MHz).

The frequency offset and repeater tone frequency are not changed by the Auto Repeater function; reset these frequencies, if necessary.

- RPt.OF: Turns OFF the function.
- RPt.R1: Activates only duplex. (default)
- RPt.R2: Activates duplex and tone.



◇ Auto power-OFF

The transceiver can be automatically turned OFF, when no key operation is performed for the specified time period. 30 minutes, 1 hour, 2 hours and OFF are selectable.

- POF.OF : Turns the function OFF. (default)
- POF.30/1H/2H : The transceiver is automatically turned OFF, when no key operation is performed for the specified time period.



NOTE: The time period is retained, even if the transceiver is turned OFF by the Auto Power OFF function. To cancel the function, select “POF.OF”

◇ Lockout

Set the transmission lockout (temporary transmission inhibit) capability.

- RLO.OF : Turns OFF the function. (default)
- RLO.RP : The transmit is inhibited when a signal with an unmatched subaudible tone is received.
- RLO.bU : Transmit is inhibited when a signal is received.



◇ Squelch delay

Set the squelch delay to short or long. The delay prevents the squelch from repeatedly opening and closing, while receiving the same signal.

- Sqd. S : Short squelch delay. (default)
- Sqd. L : Long squelch delay.



◇ DTMF speed

Set the rate at which DTMF memories send individual DTMF characters to accommodate your operating needs.

- dtd. 1 : 100 milliseconds interval; 5.0 cps rate (default)
 - dtd. 2 : 200 milliseconds interval; 2.5 cps rate
 - dtd. 3 : 300 milliseconds interval; 1.6 cps rate
 - dtd. 5 : 500 milliseconds interval; 1.0 cps rate
- (cps=characters per second)



10 SET MODES

◇ Dial assignment

Selects whether or not to use [VOL] as a tuning control or channel selector, instead of [▲] and [▼]. When [VOL] functions as a tuning control or channel selector, [▲] and [▼] function as volume controls.

Option	[VOL]	[▲]/[▼]
tOP.VO	Volume control	Tuning controls
tOP.di	Tuning control	Volume controls



◇ Display type

Set the display type for memory mode operation.

- dSP.FR : Displays the programmed frequency. (default)
- dSP.CH : Displays only the memory channel number.
 - NOTE:** Only the following functions can be used.
 - Scan function (p. 26)
 - Setting output power (p. 15)
 - DTMF Memory function (p. 33)
 - Key Lock function (p. 15)
 - Setting of following items in the Set mode (p. 36)
 - Setting of following items in the Set mode
 - The scan resume, function key timer, LCD backlight, VOX-related settings, microphone gain and DTMF TX key.
- dSP.nm : Displays the channel name.
 - If no memory name is programmed, the programmed frequency will be displayed.



◇ LCD contrast

Selects the LCD contrast.

- Lcd.LO : Sets the contrast to low.
- Lcd.At : Sets the contrast to high. (default)
 - However, if the transceiver is exposed to high temperatures, it automatically sets the contrast to low.



◇ Power save

The Power Save function allows you to conserve battery life by selecting the duty cycle of the receiver. Select the ratio of the power save time to the standby time.

To turn OFF the function, select "P-S.OF"

- P-S.OF : Turns OFF the function.
- P-S.2 : Sets the duty cycle to 1:2.
 - (ON: 0.1 second, OFF: 0.2 seconds)
- P-S.8 : Sets the duty cycle to 1:8.
 - (ON: 0.1 second, OFF: 0.8 seconds)
- P-S.16 : Sets the duty cycle to 1:16.
 - (ON: 0.1 second, OFF: 1.6 seconds)
- P-S.At : Automatically sets the duty cycle. (default)
 - When no operation occurs and no signal is received for 5 seconds, the transceiver enters the Power Save mode, and sets "1:2" as the duty cycle, and after 60 seconds, it sets "1:16" as the duty cycle.



◇ Dial acceleration

Selects whether or not to accelerate the turning speed when rotating [VOL] rapidly.

- S-S.m : Turns OFF the tuning speed acceleration.
- S-S.At : The turning speed is automatically accelerated when rapidly rotating [VOL]. (default)



10 SET MODES

◇ Microphone simple mode

Microphone Simple mode is used to assign the essential operations to the four switches (S1 to S4) on the remote control unit.

• mS .Sm

S1	Selects the Call channel.
S2	Turns the Monitor function ON or OFF.
S3	Selects memory channel 0.
S4	Selects memory channel 1.

• mS .n1 (default)

S1	Toggles the VFO mode and the memory mode.
S2	Selects the Call channel.
S3	Frequency or memory channel up.
S4	Frequency or memory channel down.

• mS .n2

S1	Toggles the VFO mode and the memory mode.
S2	Turns the Monitor function ON or OFF.
S3	Frequency or memory channel up.
S4	Frequency or memory channel down.



• User remote control unit

The circuit illustrated below is for only reference.

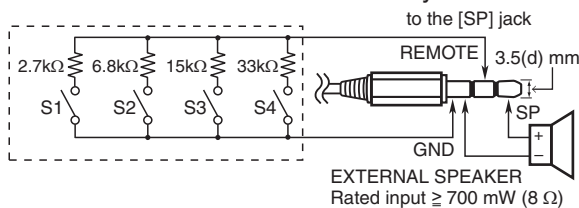

◇ Voltage display Only IC-U80/IC-U80E

The voltage of the battery is displayed at power ON. This display can be turned ON or OFF.

- VLt.OF : The battery voltage display is skipped.
- VLt.On : The battery voltage is displayed at power ON. (default)

◇ Battery protection

When the battery voltage decreases, the Battery Protection function automatically turns OFF the transceiver. Select the function option according to your battery type. (default: differs depending on the version)

- bAt.OF : Turns OFF the function. Select when you use the BP-263 battery case.
- bAt.nm : Select when you use the BP-264 **Ni-MH** battery pack.
- bAt.LI : Select when you use the BP-265 **Li-ion battery** pack.



NOTE: BE SURE to select an appropriate option according to your battery type.

◇ Auto low power

Turns the Automatic Low-power function ON or OFF. When the temperature goes below 0°C (+32°F), the function automatically sets the output power to low. In that case, the transmit power selections (Hi or Mid) are also disabled.

(default: ALP.OF)



◇ Squelch burst Only IC-U80/IC-U80E

The squelch burst function stops transmitting a subaudible tone before your transceiver stops transmitting RF, to eliminate noise. The squelch burst will be effective only when the other station uses the tone squelch function.

- Sqb.OF : The squelch burst is OFF. (default)
- Sqb.On : The squelch burst is ON.



11 CLONING

■ Cloning operation

Cloning allows you to quickly and easily transfer the programmed contents from one transceiver to another, or data between a personal computer and a transceiver, using the optional CS-V80 or CS-U80 cloning software.

◇ Cloning between two transceivers

- ① Turn OFF the power, and then connect the master and sub-transceivers using the OPC-474 cloning cable through their speaker jacks.
 - The master transceiver is used to send data to the sub-transceiver.
- ② While holding down **[FUNC](*)** and **[▲]**, turn ON the master transceiver to enter the cloning mode.
 - “CLOnE” appears
- ③ Turn ON the sub-transceiver.
- ④ Push **[PTT]** on the master transceiver.
 - “CL Out” appears on the master transceiver’s display, and the signal icon shows that data is being transferred to the sub-transceiver.
 - “CL In” appears on the sub-transceiver’s display, and the signal icon shows that data is being received from the master transceiver.
- ⑤ When the cloning is finished, turn OFF both transceiver’s power, and then turn ON the power again to exit the cloning mode.

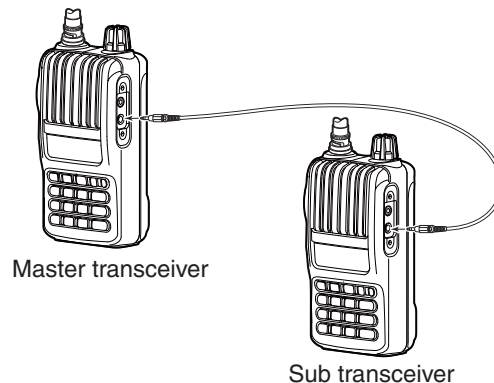

NOTE:

- DO NOT push **[PTT]** on the sub-transceiver during cloning. This will cause an error.
- DO NOT disconnect the cloning cable or turn OFF the power during cloning. This will cause an error.

◇ Cloning using a PC

Data can be transferred to and from a PC, using the optional CS-V80 or CS-U80 cloning software and an OPC-478 (RS-232C type) or OPC-478UC (USB type) CLONING CABLE.

Consult the INSTRUCTIONS and the Help file that come with the cloning software, for details.

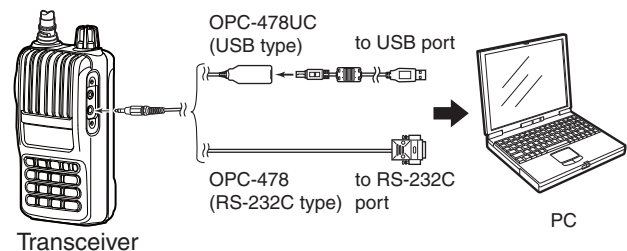

12 RESETTING

■ Resetting

The LCD may occasionally display erroneous information (e.g. when first applying power). This may be caused externally by static electricity or by other factors.

If this problem occurs, turn power OFF. After waiting a few seconds, turn power ON again. If the problem persists, perform either or both of procedures below.

◇ Partial reset

If you want to reset the operating conditions (VFO frequency, VFO settings, and Set modes contents) without clearing the memory contents, do a partial reset.

- ① Hold down [⏻] for 1 second to turn OFF the power.
- ② While holding down [VFO/MR/CALL], hold down [⏻] for 1 second to turn ON the power.

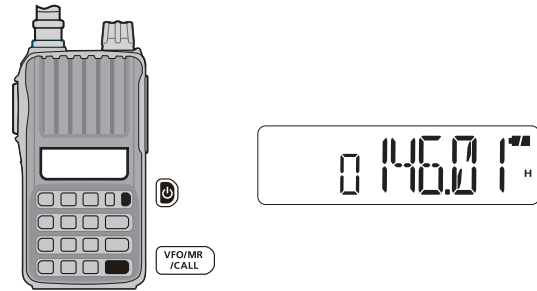

◇ All reset

The all reset clears all programming and returns all settings to their factory defaults.

- ① Hold down [⏻] for 1 second to turn OFF the power.
- ② While holding down [MONI] and [VFO/MR/CALL], hold down [⏻] for 1 second to turn ON the power.
 - "CLEAR" appears when the transceiver is totally reset.

CAUTION: The all reset returns all programmed contents to their default settings.

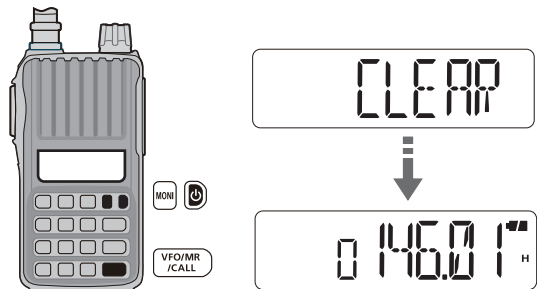

13 TROUBLE SHOOTING

If your transceiver seems to be malfunctioning, please check the followings before sending it to the service center.

PROBLEM	POSSIBLE CAUSE	SOLUTION	REF.
No power comes on.	<ul style="list-style-type: none"> The battery is exhausted. The battery polarity is reversed. Bad connection of a battery pack or case. 	<ul style="list-style-type: none"> Charge the battery pack, or replace the batteries. Check the battery polarity. Clean battery terminals. 	pp. 6–9 p. 9 p. 9
No sound comes from the speaker.	<ul style="list-style-type: none"> Volume level is too low. An external speaker or a cloning cable is connected to the [SP] jack. 	<ul style="list-style-type: none"> Rotate [VOL] to adjust to the volume level. Check the external speaker connection or remove the cloning cable. 	– –
Transmitting is impossible.	<ul style="list-style-type: none"> The battery is exhausted. Transmission is inhibited. The Lockout function is activated. 	<ul style="list-style-type: none"> Charge the battery pack, or replace the batteries. Set the 'TX permission' item to "ON" in the Set mode. Turn OFF the Lockout function. 	pp. 6–9 p. 39 p. 20
Transmitting using the VOX function is impossible.	<ul style="list-style-type: none"> The VOX gain is set to OFF or too low. The microphone gain is too low. Transmission is inhibited. 	<ul style="list-style-type: none"> Set the VOX gain to a suitable level. Set the microphone gain to a suitable level. Set the 'TX permission' item to "ON" in the Set mode. 	p. 50 p. 39 p. 39
No direct contact possible with other stations.	<ul style="list-style-type: none"> A different tone or code is used for the tone or DTCS squelch. 	<ul style="list-style-type: none"> Check the tone or DTCS code by the tone scan. 	p. 32
Frequency cannot be set.	<ul style="list-style-type: none"> The Key Lock function is activated. The memory mode, Call channel mode, or weather channel mode* is selected. 	<ul style="list-style-type: none"> Push [FUNC](*), and then hold down [F-O](# ENT) for 1 second to cancel the Key Lock function. Push [VFO/MR/CALL] several times to select the VFO mode. 	– –
A programmed scan does not start.	<ul style="list-style-type: none"> The memory mode, Call channel mode, or weather channel mode* is selected. The same frequency has been programmed in the scan edge channels, "XA"–"Xb." 	<ul style="list-style-type: none"> Push [VFO/MR/CALL] several times to select the VFO mode. Program different frequencies as the scan edge channels. 	– p. 27
A memory scan does not start.	<ul style="list-style-type: none"> The memory mode is not selected. Only one or no memory channel has been programmed. 	<ul style="list-style-type: none"> Push [VFO/MR/CALL] several times to select the memory mode. Program 2 or more memory channels. 	p. 15 p. 25
The function display shows erroneous information.	<ul style="list-style-type: none"> The CPU is malfunctioning. External factors have caused a fault. 	<ul style="list-style-type: none"> Reset the CPU. Remove and re-attach the battery pack or case. 	p. 46 p. 1

*For only USA version of IC-V80.

14 OPTIONS

- **BP-263** BATTERY CASE
Battery case for LR6 (AA) × 6 alkaline batteries.
- **BP-264** NI-MH BATTERY PACK
7.2 V/1400 mAh (Minimum)/1420 mAh (Typical) Ni-MH battery pack. Battery life: 13 hours (approximately; FM, high power, Tx : Rx : Standby = 5:5:90)
- **BP-265** LI-ION BATTERY PACK
7.4 V/1900 mAh (Minimum)/2000 mAh (Typical) Lithium Ion battery pack. Battery life: 19 hours (approximately; FM, high power, Tx : Rx : Standby = 5:5:90)
- **BC-191** DESKTOP CHARGER+**BC-123S** AC ADAPTER
For rapid charging of the Ni-MH battery pack. An AC adapter may be supplied with the charger, depending on the version.
Charging time: approximately 2 hours for the BP-264.
- **BC-192** DESKTOP CHARGER+**BC-147S** AC ADAPTER
For regular charging of the Ni-MH battery pack. An AC adapter may be supplied with the charger, depending on the version.
Charging time: approximately 16 hours for the BP-264.
- **BC-193** DESKTOP CHARGER+**BC-123S** AC ADAPTER
For rapid charging of the Li-ion battery pack. An AC adapter may be supplied with the charger, depending on the version.
Charging time: approximately 2.5 hours for the BP-265.
- **CP-23L** CIGARETTE LIGHTER CABLE
Allows charging of the battery packs through a 12 V cigarette lighter socket. (For only BC-191/BC-193)
- **OPC-515L** DC POWER CABLE
Allows charging of the battery packs using a 12 V DC power source instead of the AC adapter. (For all chargers)
- **MB-124** BELT CLIP
Exclusive alligator-type belt clip.
- **MB-130** VEHICLE CHARGER BRACKET
Vehicle mounting bracket for the BC-191, BC-192 and BC-193 battery chargers.
- **FA-B2E/FA-B2F** VHF ANTENNA
The same antenna that is supplied with IC-V80/IC-V80E.
Antenna length: FA-B2E: Approximately 167 mm; 6.6 in
FA-B2F: Approximately 150 mm; 5.9 in
- **FA-B70C** UHF ANTENNA
The same antenna that is supplied with IC-U80/IC-U80E.
- **HM-153L** EARPHONE-MICROPHONE
Ideal for hands-free operation: clip the HM-153L (with integrated PTT switch) to your lapel or breast pocket.
- **HM-158L/HM-159L** SPEAKER-MICROPHONE
Combination speaker-microphone that provides convenient operation while hanging the transceiver on your belt.
- **HS-94/HS-95/HS-97** HEADSET
+**OPC-2004** PLUG ADAPTER CABLE
HS-94 : Ear hook type
HS-95 : Neck & arm type
HS-97 : Throat microphone
OPC-2004 : Allows you to connect the HS-94/HS-95/HS-97 to the transceiver. After connecting, the VOX function can be used.
- **SP-27** TUBE EARPHONE
Provides clear audio in noisy environments.
- **CS-V80/CS-U80** CLONING SOFTWARE
+**OPC-478/OPC-478UC** CLONING CABLE
Provides quick and easy programming of such settings as memory channels and Set modes contents.
- **OPC-474** CLONING CABLE
For transceiver-to-transceiver cloning.

Some options may not be available in some countries. Please ask your dealer for details.

Approved Icom optional equipment is designed for optimal performance when used with an Icom transceiver.
Icom is not responsible for the destruction or damage to an Icom transceiver in the event the Icom transceiver is used with equipment that is not manufactured or approved by Icom.

14 OPTIONS

■ VOX function

The transceiver has a VOX function, which allows hands-free operation.

An optional HS-94, HS-95 or HS-97 headset and the OPC-2004 plug adapter cable are also required for operation.

What is VOX?

The VOX (voice operated transmission) function starts transmission when you speak into the microphone, without pushing [PTT]; and then, automatically returns to reception when you stop speaking.

◇ Optional unit connection

- ① Hold down [⏻] for 1 second to turn OFF the power.
- ② Remove the jack cover. (p. 1)
- ③ Connect the optional HS-94, HS-95 or HS-97 and OPC-2004.

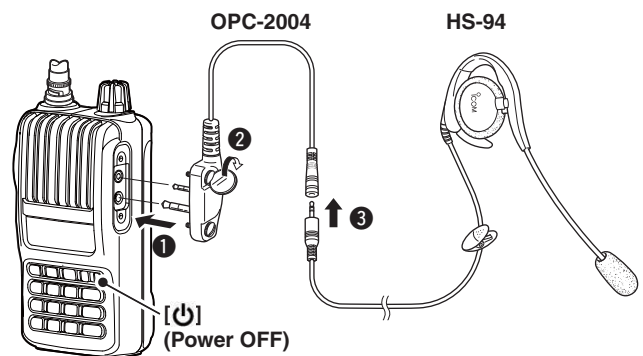

◇ Turning the VOX function ON or OFF

- ① Connect an optional headset and plug adapter cable to the transceiver, and then turn ON the power.
- ② Push [FUNC](*), and then push [VOX](2) to turn the VOX function ON or OFF.
 - "VOX" appears when the VOX function is ON.

Push [FUNC](*), and then push [2] [VOX].



NOTE:

- When using the VOX function, adjust the microphone gain and the VOX-related settings (p. 50) to suit your operating environment (including your headset performance).
- Set the microphone gain before setting the VOX gain in the Set mode (p. 39). We recommend setting the microphone gain to 3.
- When 'TX permission' is set to "OFF" in the Set mode (p. 39), you cannot transmit using the VOX function.

14 OPTIONS

■ VOX function (Continued)

◇ VOX-related settings

The VOX gain, VOX delay, and VOX time-out timer is set in the Set mode.

- ① Connect an optional headset and plug adapter cable to the transceiver, and then turn ON the power.
- ② Push **[FUNC](*)**, and then push **[VOX](2)** to turn ON the VOX function.
- ③ Push **[FUNC](*)**, and then push **[SET](8)** to enter the Set mode.
- ④ Push **[▲]** or **[▼]** to select the VOX gain (VOX), VOX delay (VXd), or VOX time-out timer (Vto) item.
- ⑤ Rotate **[VOL]** to select a option.
- ⑥ Push **[# ENT]** to exit the Set mode.

▨ The VOX function is not activated while in the Set mode.

• VOX gain

The VOX gain level can be adjusted between 1 (minimum) and 10 (maximum), or turned OFF. Higher values make the VOX function more sensitive to your voice.

(default: VOX.05)

➔ While speaking into the headset microphone, adjust the VOX gain until “On” continuously appears on the display.

▨ If “On” is intermittent, be sure the VOX delay is set long enough to allow normal pauses in speech, but keep the VOX ON until you finish speaking.

✓ CONVENIENT!

While transmitting using the VOX function, you can adjust the VOX gain simply by rotating **[VOL]**.

• VOX delay

Set the VOX delay to between 0.5 and 3.0 seconds (in 0.5 seconds steps). The VOX delay is the amount of time the transmitter stays ON after you stop speaking.

(default: VXd.10)

• VOX time-out timer

Set the VOX time-out timer to between 1, 2, 3 (default), 4, 5, 10 and 15 minutes to prevent accidental prolonged transmission for the VOX function.

To turn OFF the function, select “Vto.OF”

▨ The VOX time-out timer must be set shorter than the time-out timer, otherwise this timer will not function.

Push **[FUNC](*)**, and then push **[VOX](2)**.



• The “VOX gain” item in the Set mode



The VOX function is turned OFF.



The VOX gain is set to 10 (max.)



Appears

• The “VOX delay” item in the Set mode



The VOX delay is set to 1 second.



The VOX delay is set to 3 seconds.

• The “VOX time-out timer” item in the Set mode



The VOX time-out timer is set to 3 minutes. (default)



VOX time-out timer is set to 15 minutes (maximum).

15 SPECIFICATIONS

■ IC-V80/IC-V80E

◇ General

- Frequency coverage

Version	TX	RX
USA AUS	144–148	136–174*
CHN EXP	136–174*	136–174*
EUR UK, FRA KOR	144–146	144–146

*Guaranteed: Only 144–148 MHz range (unit: MHz)

- Mode : FM, FM-N
- Number of memory channels : 207 (including 6 scan edges and 1 Call channel)
- Usable temperature range : –20°C to +60°C; –4°F to +140°F
- Tuning steps : 5, 10, 12.5, 15, 20, 25, 30 and 50 kHz
- Frequency stability : ±2.5 ppm (–20°C to +60°C; –4°F to +140°F)
- Power supply : Icom specified battery pack or case
- Current drain (at 7.2 V DC: typical)
 - Transmit at 5.5 W (High) : 1.4 A
 - at 2.5 W (Mid) : 0.9 A
 - at 0.5 W (Low) : 0.6 A
 - Receive standby : 65 mA
 - power save : 20 mA
 - maximum audio : 310 mA (internal speaker)
180mA (external speaker)
- Antenna connector : BNC (50 Ω)
- Dimensions (projections not included) : 58(W) × 112(H) × 30(D) mm; 2.3(W) × 4.4(H) × 1.2(D) in
- Weight (approximately) : 140 g; 4.9 oz (without battery pack, case and antenna)

◇ Transmitter

- **Modulation** system : Variable reactance frequency modulation
- Output power (at 7.2 V DC) : High 5.5 W, Mid 2.5 W, Low 0.5 W
- Maximum frequency deviation : FM (wide) ±5.0 kHz
FM (narrow) ±2.5 kHz
- Spurious emissions : Less than –60 dBc
- External microphone connector : 3-conductor 2.5 (d) mm ($\frac{1}{10}$ ")/2.2 kΩ

◇ Receiver

- Receive system : Double-conversion superheterodyne
- **Intermediate frequencies** : 1st: 21.7 MHz, 2nd: 450 kHz
- **Sensitivity** (at 12 dB SINAD) : 0.14 μV typical
- Squelch sensitivity (threshold) : 0.1 μV typical
- Selectivity : FM (wide) 70 dB typical
FM (narrow) 50 dB typical
- Spurious and image rejection : 75 dB typical
- Intermodulation : FM (wide) 70 dB typical
FM (narrow) 65 dB typical
- Audio output power (at 10% distortion)
 - Internal speaker : 0.75 W typical with a 16 Ω load
 - External speaker : 0.45 W typical with a 8 Ω load
- External speaker connector : 3-conductor 3.5(d) mm; ($\frac{1}{8}$ ")/8 Ω

All stated specifications are subject to change without notice or obligation.

15 SPECIFICATIONS

■ IC-U80/IC-U80E

◇ General

- Frequency coverage : 400.000–470.000 MHz
- Mode : FM, FM-N
- Number of memory channels : 207 (including 6 scan edges and 1 Call channel)
- Usable temperature range : –20°C to +60°C; –4°F to +140°F
- Tuning steps : 5, 10, 12.5, 15, 20, 25, 30 and 50 kHz
- Frequency stability : ±2.5 ppm (–20°C to +60°C; –4°F to +140°F)
- Power supply : Icom specified battery pack or case
- Current drain (at 7.2 V DC: typical) :
 - Transmit at 4 W (High) : 1.4 A
 - at 2 W (Mid) : 1.0 A
 - at 0.5 W (Low) : 0.5 A
 - Receive standby : 58 mA
 - power save : 32 mA
 - maximum audio : 280 mA (internal speaker)
160 mA (external speaker)
- Antenna connector : BNC (50 Ω)
- Dimensions (projections not included) : 58(W) × 112(H) × 30(D) mm; 2.3(W) × 4.4(H) × 1.2(D) in
- Weight (approximately) : 140 g; 4.9 oz (without battery pack, case and antenna)

◇ Transmitter

- **Modulation** system : Variable reactance frequency modulation
- Output power (at 7.2 V DC) : High 4 W, Mid 2 W, Low 0.5 W
- Maximum frequency deviation : FM (wide) ±5.0 kHz
FM (narrow) ±2.5 kHz
- Spurious emissions : Less than –65 dBc
- External mic. connector : 3-conductor 2.5 (d) mm (1/10")/2.2 kΩ

◇ Receiver

- Receive system : Double-conversion superheterodyne
- **Intermediate frequencies** : 1st: 46.35 MHz, 2nd: 450 kHz
- **Sensitivity** (at 12 dB SINAD) : 0.2 μV typical
- Squelch sensitivity (threshold) : 0.11 μV typical
- Selectivity : FM (wide) 70 dB typical
FM (narrow) 60 dB typical
- Spurious and image rejection : 70 dB typical
- Intermodulation : 70 dB typical
- Audio output power (at 10% distortion) :
 - Internal speaker : 0.75 W typical with a 16 Ω load
 - External speaker : 0.4 W typical with a 8 Ω load
- External speaker connector : 3-conductor 3.5(d) mm; (1/8")/8 Ω

All stated specifications are subject to change without notice or obligation.

Count on us!

