



SERVICE MANUAL

UHF TRANSCEIVER

ID-31A
ID-31E

S-14813XZ-C1
Feb. 2012

Icom Inc.

INTRODUCTION

This service manual describes the latest technical information for the **ID-31A/ID-31E** UHF TRANSCEIVER, at the time of publication.

MODEL	VERSION	SUPPLIED CHARGER
ID-31A	USA	BC-167SA
	KOR	BC-167SD
	EXP	BC-167SA
	EXP-01	BC-167SD
	AUS	BC-167SV
ID-31E	EUR	BC-167SD
	UK	N/A
	ITR	BC-167SD

To upgrade quality, any electrical or mechanical parts and internal circuits are subject to change without notice or obligation.

CAUTION

NEVER connect the transceiver to an AC outlet or to a DC power supply that uses more than the specified voltage. This will ruin the transceiver.

DO NOT expose the transceiver to rain, snow or any liquids.

DO NOT reverse the polarities of the power supply when connecting the transceiver.

DO NOT apply an RF signal of more than 20 dBm (100 mW) to the antenna connector. This could damage the transceiver's front-end.

ORDERING PARTS

Be sure to include the following four points when ordering replacement parts:

1. 10-digit Icom part number
2. Component name
3. Equipment model name and unit name
4. Quantity required

<ORDER EXAMPLE>

1110003491 S.IC TA31136FNG ID-31A MAIN UNIT 5 pieces
8820001210 Screw 2438 screw ID-31E Top cover 10 pieces

Addresses are provided on the inside back cover for your convenience.



(ID-31A)

REPAIR NOTES

1. Make sure that the problem is internal before disassembling the transceiver.
2. **DO NOT** open the transceiver until the transceiver is disconnected from its power source.
3. **DO NOT** force any of the variable components. Turn them slowly and smoothly.
4. **DO NOT** short any circuits or electronic parts. An insulated tuning tool **MUST** be used for all adjustments.
5. **DO NOT** keep power ON for a long time when the transceiver is defective.
6. **DO NOT** transmit power into a Standard Signal Generator or a Sweep Generator.
7. **ALWAYS** connect a 30–40 dB attenuator between the transceiver and a Deviation Meter or Spectrum Analyzer, when using such test equipment.
8. **READ** the instructions of the test equipment thoroughly before connecting it to the transceiver.

TABLE OF CONTENTS

SECTION 1 SPECIFICATIONS

SECTION 2 INSIDE VIEWS

SECTION 3 DISASSEMBLY INSTRUCTION

SECTION 4 CIRCUIT DESCRIPITON

4-1	RECEIVER CIRCUITS.....	4-1
4-2	TRANSMITTER CIRCUITS.....	4-2
4-3	FREQUENCY SYNTHESIZER CIRCUITS.....	4-3
4-4	VOLTAGE DIAGRAM.....	4-3
4-5	PORT ALLOCATIONS.....	4-4

SECTION 5 ADJUSTMENT PROCEDURES

5-1	PREPARATION.....	5-1
5-2	FREQUENCY ADJUSTMENT.....	5-3
5-3	TRANSMIT ADJUSTMENT.....	5-3
5-4	RECEIVE ADJUSTMENT.....	5-7

SECTION 6 PARTS LIST

SECTION 7 MECHANICAL PARTS

SECTION 8 BOARD LAYOUTS

SECTION 9 BLOCK DIAGRAM

SECTION 10 VOLTAGE DIAGRAM

SECTION 1

SPECIFICATIONS

◇ General

- Frequency coverage : (unit: MHz)

Version	TX	RX
U.S.A.	420-450* ¹	400-479* ¹
AUS	420-450* ²	400-479* ²
EUR, KOR	430-440	430-440
UK	430-440	400-479* ²
ITR	430-434, 435-438	430-434, 435-438
EXP	400-479* ²	400-479* ²
EXP-1	430-440	400-479* ²

*¹Guaranteed 440-450 MHz only, *²Guaranteed 430-440 MHz only

- Mode : FM, FN-N, DV
- No. of memory channels : 552
(incl. 50 scan edges and 2 call channels)
- Usable temp. range : -20°C to +60°C; -4°F to +140°F
- Tuning steps : 5, 6.25, 10, 12.5, 15, 20, 25, 30, 50, 100, 125 and 200 kHz
- Frequency stability : ±2.5 ppm
(-20°C to +60°C; -4°F to +140°F)
- Power supply : 10.0-16.0 V DC for external DC power, or specified Icom's battery pack
- Digital transmission speed: 4.8 kbps
- Voice coding speed : 2.4 kbps
- Current drain (at 7.4 V DC) :
 - TX (at 5 W) : Less than 2.5 A
 - RX Max. output FM : Less than 350 mA (Internal speaker)
Less than 200 mA (External speaker)
 - DV : Less than 450 mA (Internal speaker)
Less than 300 mA (External speaker)
- Antenna connector : SMA (50 Ω)
- Dimensions : 58(W)×95(H)×25.4(D) mm;
(projections not included) 2.3(W)×3.7(H)×1(D) in
- Weight (approximately) : 140 g; 4.94 oz
(without battery pack/case and ant.)

◇ Transmitter

- Modulation system :
 - FM : Variable reactance freq. modulation
 - DV : GMSK reactance freq. modulation
- Output power (at 7.4 V DC) : High 5.0 W, Mid. 2.5 W, Low 0.5 W, S-Low 0.1 W (Typical)
- Max. frequency deviation : ±5.0 kHz (FM wide: approx.)
±2.5 kHz (FM narrow: approx.)
- Spurious emissions : Less than -60 dBc at High/Mid.
Less than -13 dBm at Low/S-Low
- Ext. mic. impedance : 2.2 kΩ

◇ Receiver

- Receive system : Double-conversion superheterodyne
- Intermediate frequencies : 46.35 MHz (1st IF)
450 kHz (2nd IF)
- Sensitivity (except spurious points):
 - FM (1 kHz/3.5 kHz Dev.; 12 dB SINAD) : Less than -15 dBμ
 - DV (PN9/GMSK 4.8 kbps; BER 1%) : Less than -11 dBμ
- Audio output power (at 10% distortion)
 - Internal speaker : More than 0.4 W with a 16 Ω load
 - External speaker : More than 0.2 W with a 8 Ω load
- Selectivity :
 - FM (Wide) : More than 55 dB
 - FM (Narrow), DV : More than 50 dB
- Ext. speaker connector : 3-conductor 3.5(d) mm; (1/8")/8 Ω
- Spurious and image rejection ratio : More than 60 dB
- Squelch Sensitivity (threshold, 1 kHz/3.5 kHz Dev.): Less than -15 dBμ

All stated specifications are subject to change without notice or obligation.

**• LOGIC UNIT
(TOP VIEW)**

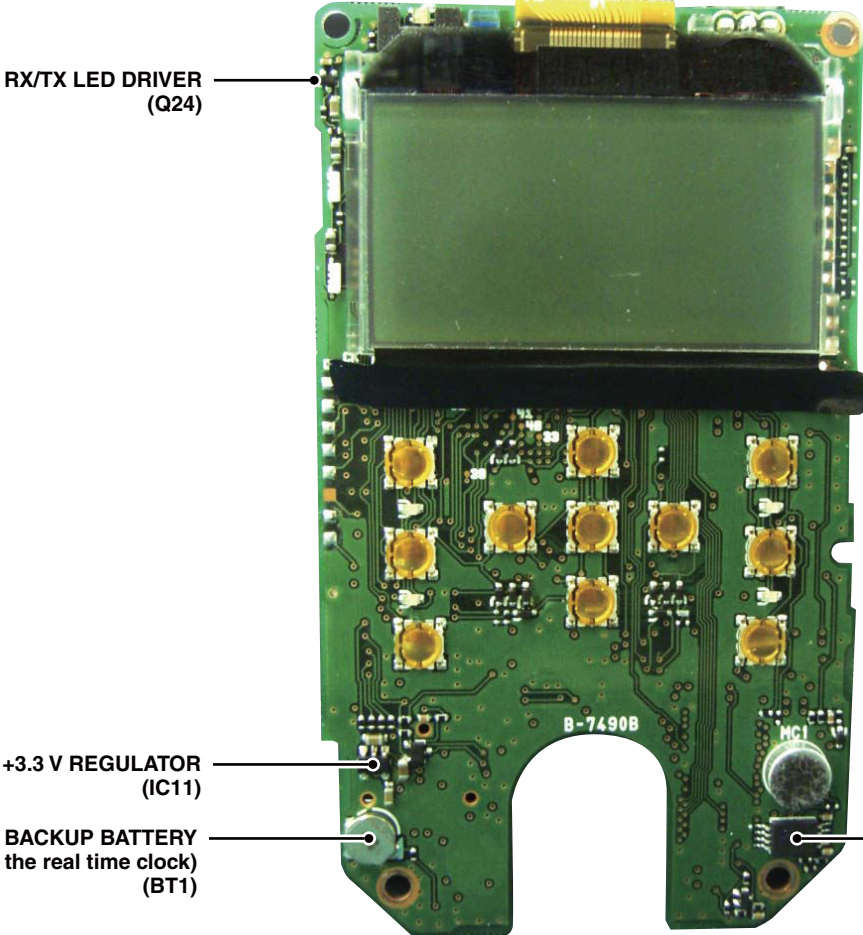

**RX/TX LED DRIVER
(Q24)**

**+3.3 V REGULATOR
(IC11)**

**BACKUP BATTERY
(For the real time clock)
(BT1)**

**MIC/VOX AMP
(IC19)**

• LOGIC UNIT
(BOTTOM VIEW)

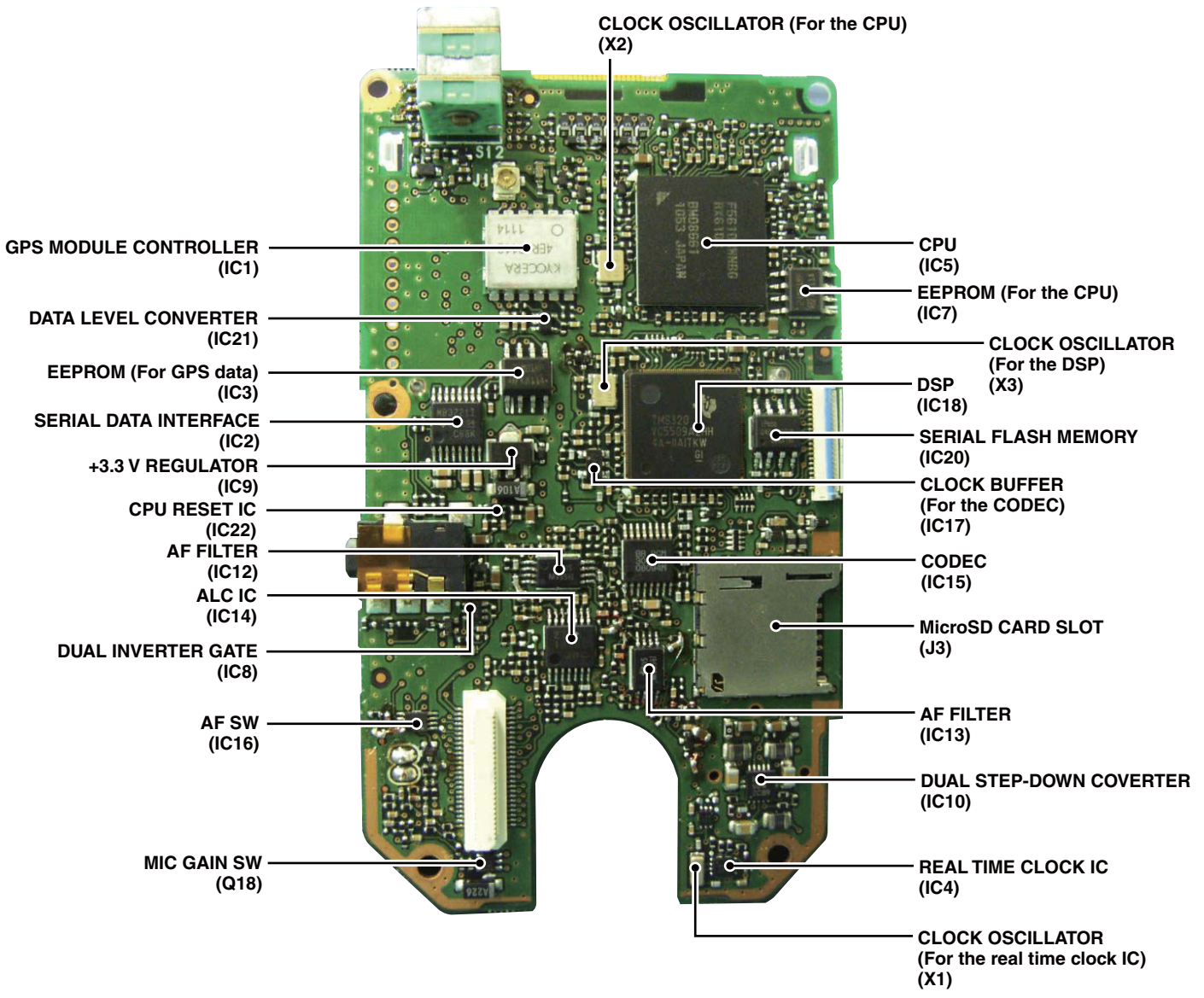

• MAIN UNIT
(TOP VIEW)

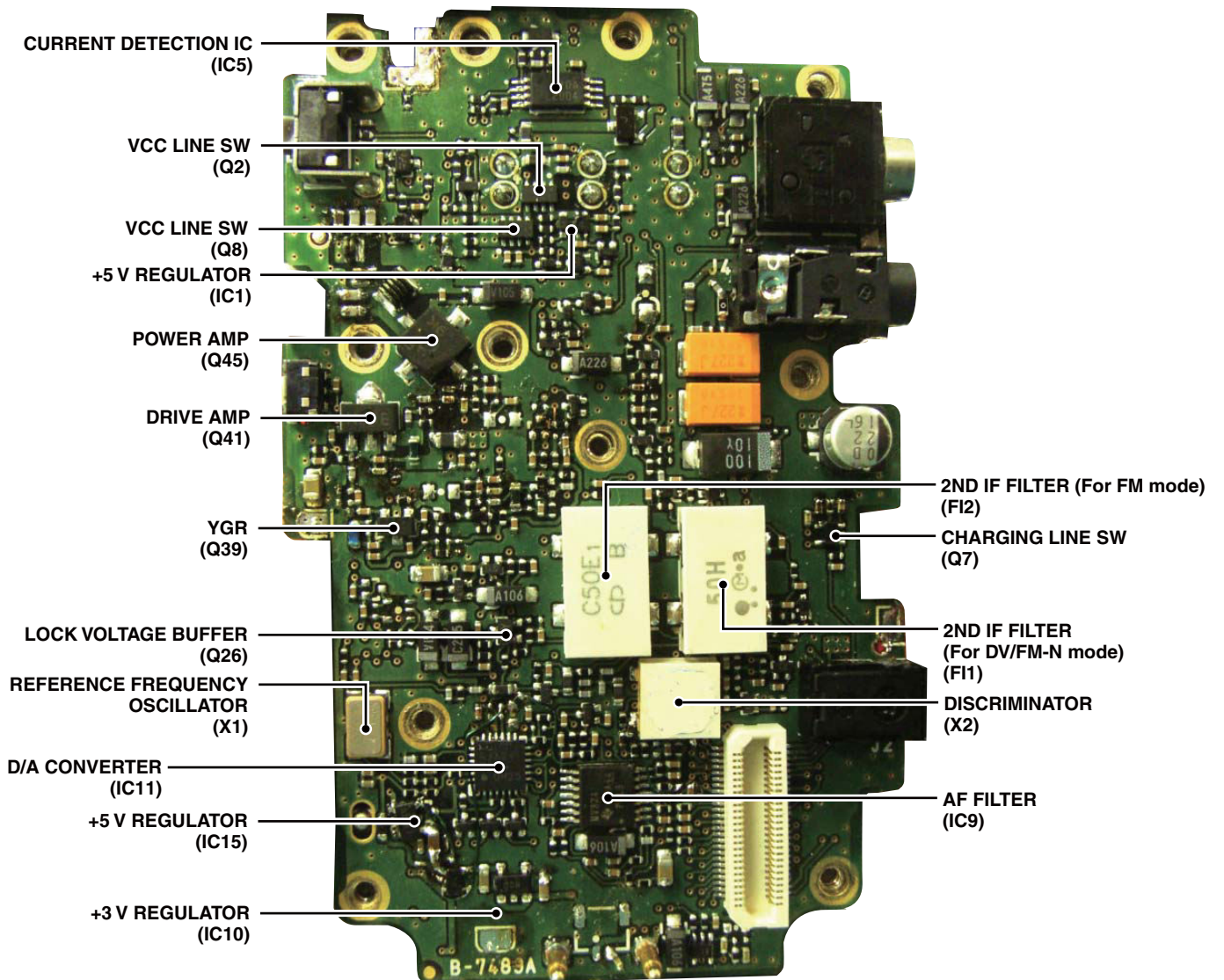

• MAIN UNIT
(BOTTOM VIEW)

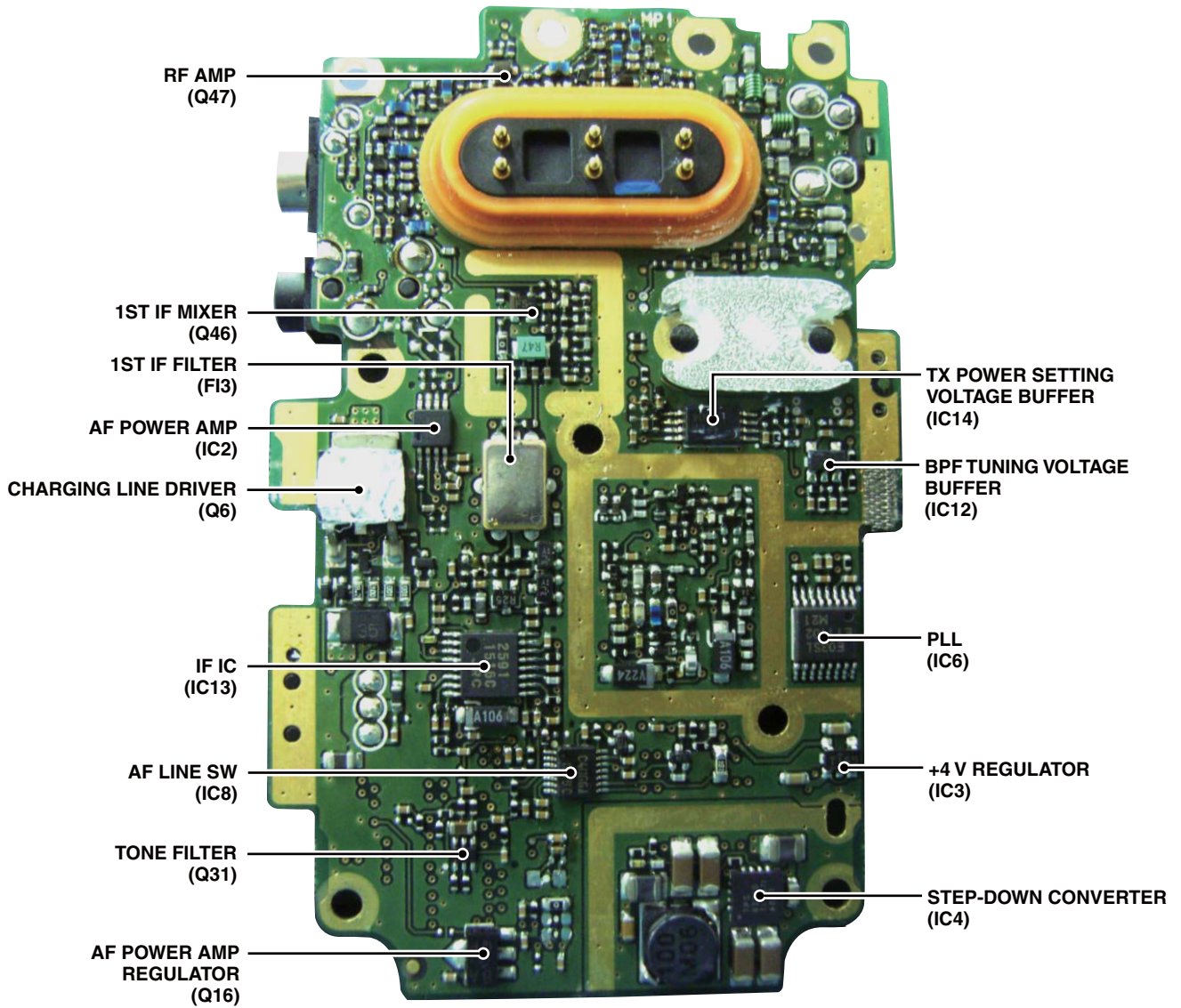

SECTION 3 DISASSEMBLY INSTRUCTION

1. REMOVING THE LOGIC UNIT

1) Remove 2 dials and antenna nut from the front panel.

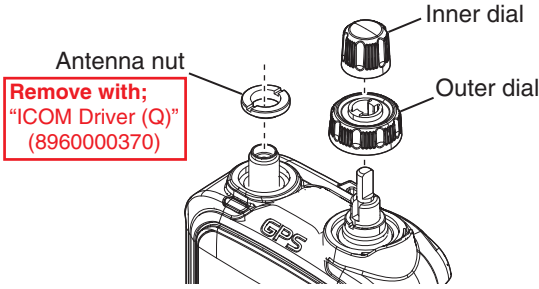

2) Remove 2 screws from the bottom of chassis.

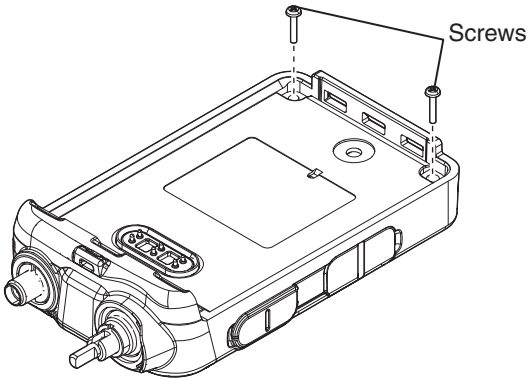

3) Take out the LOGIC UNIT with chassis from the front panel.

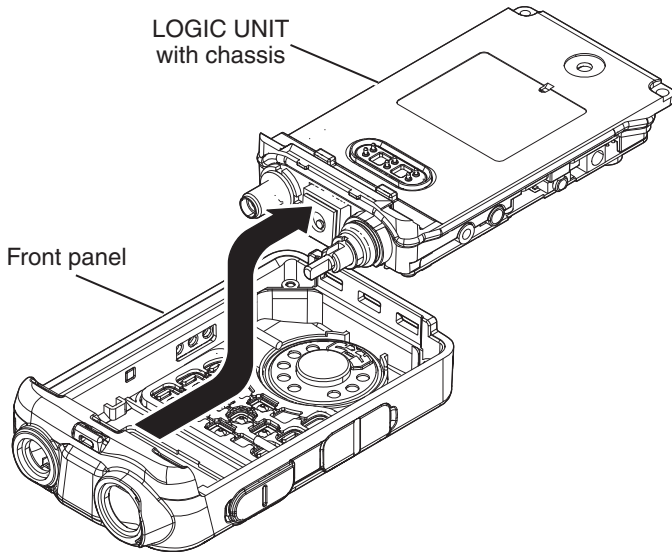

4) Remove 5 screws from the LOGIC UNIT.

5) Unsolder 6 points at the rotary encoder.

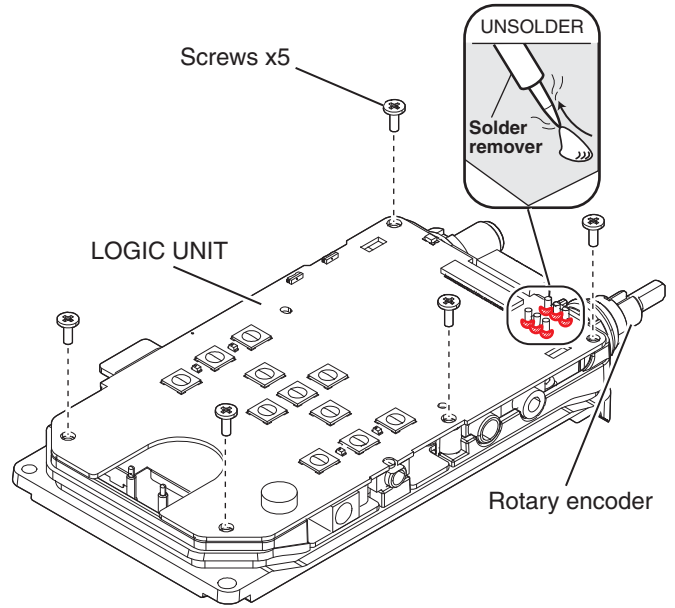

6) Separate the LOGIC UNIT from the chassis, and then disconnect the coaxial cable from the LOGIC UNIT.

BE CAREFUL about the **coaxial cable** and **connector** when separating the LOGIC UNIT from the chassis.

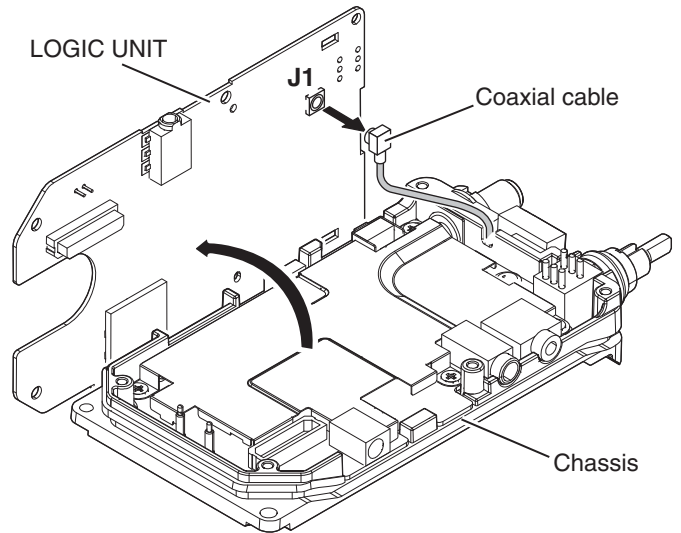

For easy separation of the CHASSIS

Use a suction lifter to lift the bottom of the CHASSIS up.

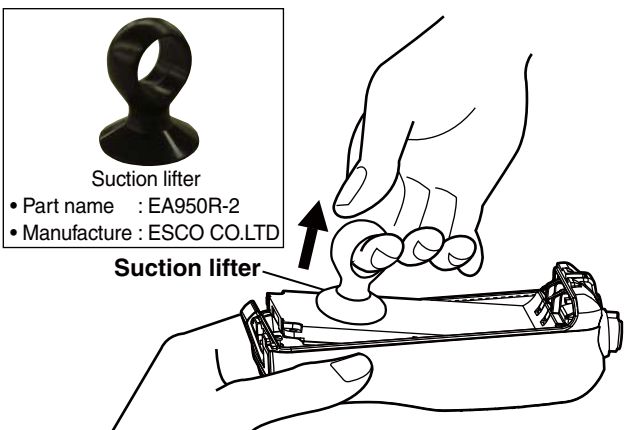

(Continued on page 3-2)

2. REMOVING THE MAIN UNIT

1) Unsolder 3 points on the shield plate.

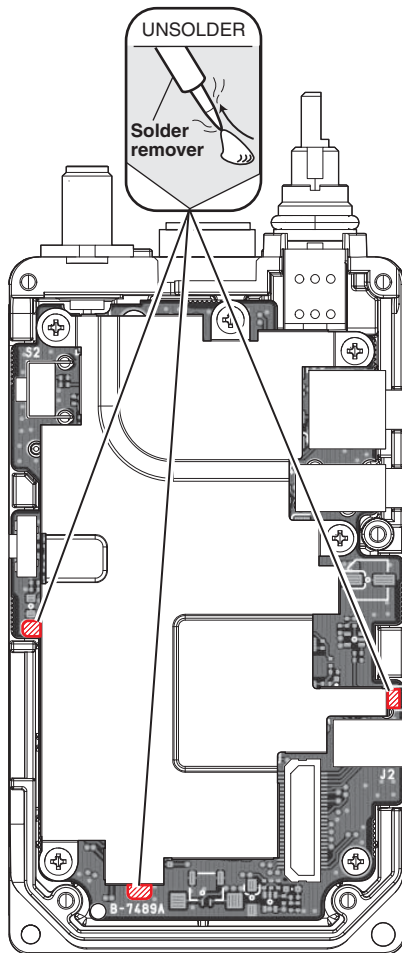

3) Unsolder a point at the antenna connector.

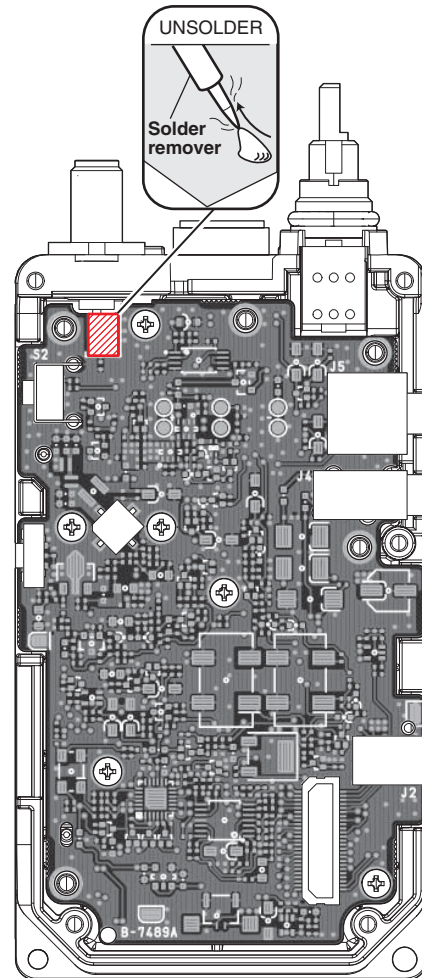

2) Remove 5 screws from the shield plate, and then remove it.

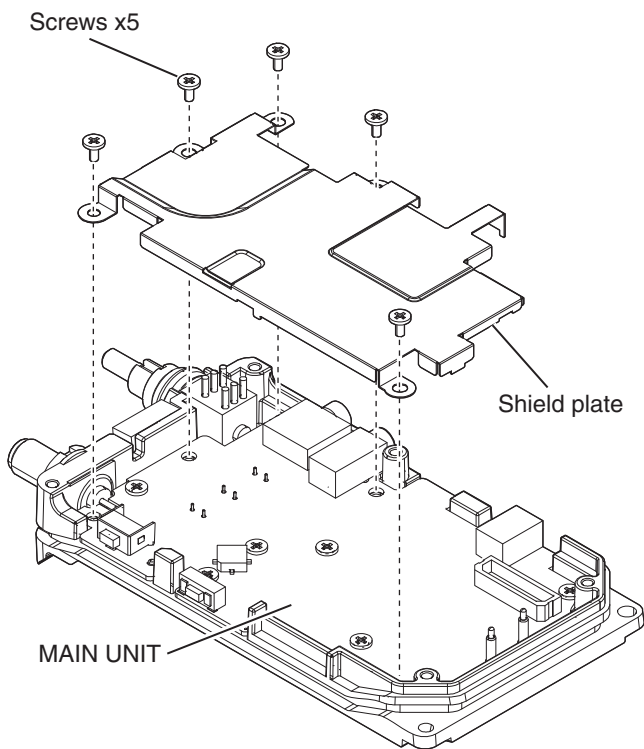

4) Remove 6 screws from the MAIN UNIT, and then remove the MAIN UNIT from the chassis.

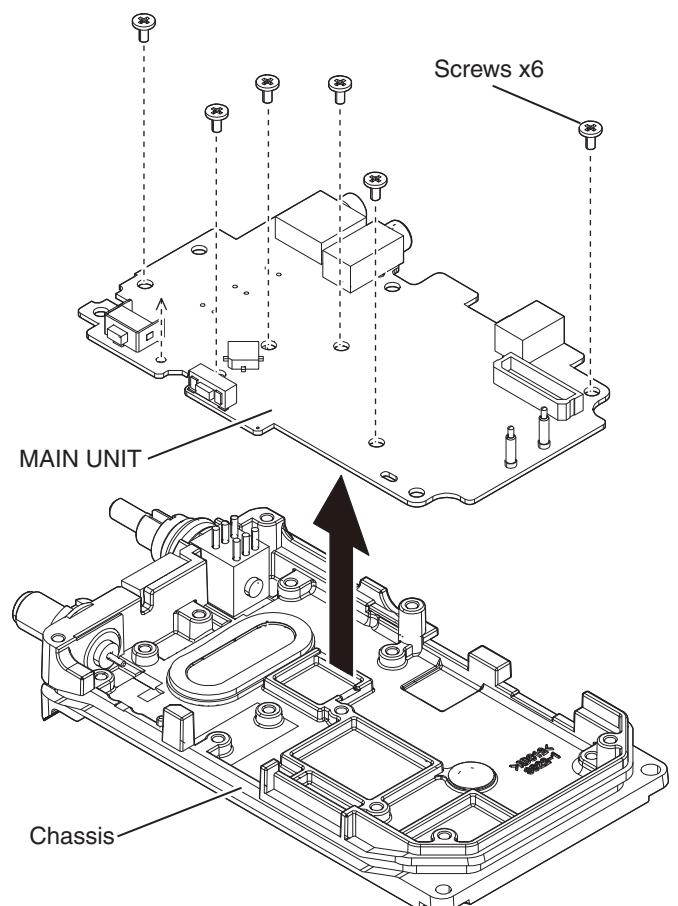

4-1 RECEIVE CIRCUITS

RF CIRCUITS (MAIN UNIT)

The RX signal from the antenna is passed through two LPFs (L32, L34, C302, C303, C306, C307, C312 and L29, C281, C285), ANT SW (D24, D25, D31, D33, L36, C313, C315, C319) and tuned BPF (D32, L43, C353), and then applied to the RF AMP (Q47).

The amplified signal is passed through the tuned BPF (D27, D29, D30, L28, L31, L33, C286, C290, C292, C293, C297, C299–C301, C304, C305), and then applied to the 1st IF circuits.

• RF CIRCUITS

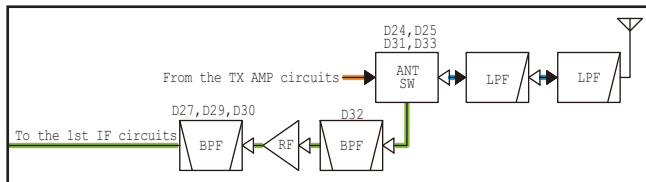

1ST IF CIRCUITS (MAIN UNIT)

The RX signal from the RF circuits is applied to the 1st IF mixer (Q46), and mixed with the 1st LO signal from the VCO (Q27, D10–D12), resulting in the 46.35 MHz 1st IF signal.

The 1st IF signal is passed through the 1st IF filter (FI3) and limiter (D23), and then applied to the 1st IF AMP (Q44). The amplified signal is passed through another limiter (D22), and then applied to the 2nd IF circuits.

• 1ST IF CIRCUITS

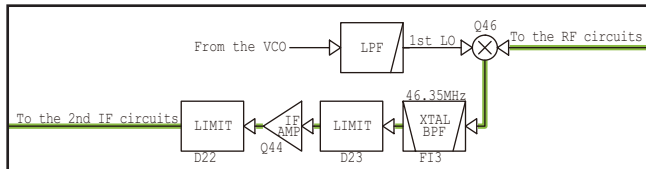

2ND IF CIRCUITS (MAIN UNIT)

The 1st IF signal from the 1st IF circuits is applied to the IF IC (IC13, pin 16). The IF IC contains the 2nd mixer, 2nd IF AMP, detector, and so on, in its package.

The 1st IF signal is mixed with the 2nd LO signal from the reference frequency oscillator (TCXO: X1), resulting in the 450 kHz 2nd IF signal. The 2nd IF signal is passed through the 2nd IF filter (FI1: for DV/FM-N mode, FI2: for FM mode) to remove sideband noise. The filtered signal is amplified by the 2nd IF AMP, and demodulated by the quadrature detector with discriminator (X2).

The demodulated AF signal is applied to the RX AF circuits.

• 2ND IF CIRCUITS

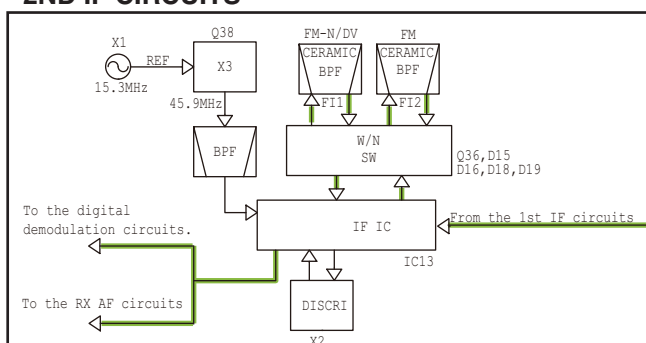

RX AF CIRCUITS (MAIN AND LOGIC UNITS)

• While operating in the DV mode

The demodulated AF signal is passed through the LPF (MAIN UNIT: R118, R121, C122, C130, C135), and then applied to the digital demodulation circuits on the LOGIC UNIT.

The AF signal from the MAIN UNIT is amplified by the AF AMP (LOGIC UNIT: IC13A, pins 1, 2) and passed through the LPF (LOGIC UNIT: IC13B, pins 6, 7), and then applied to the linear CODEC (LOGIC UNIT: IC15, pin 3) to be encoded in to a digital audio signal.

The digital audio signal is demodulated by the DSP (LOGIC UNIT: IC18), and then applied to the linear codec (LOGIC UNIT: IC15) to be decoded into an analog audio signal.

The decoded AF signal is applied to the MAIN UNIT.

The AF signal is passed through the mode SW (MAIN UNIT: IC8, pins 3, 4) and AF filters (MAIN UNIT: IC9B, pins 6, 7 and IC9C, pins 9, 10), and then applied to the D/A converter (MAIN UNIT: IC11, pin 13) to be adjusted in level.

• DIGITAL DEMODULATION CIRCUITS

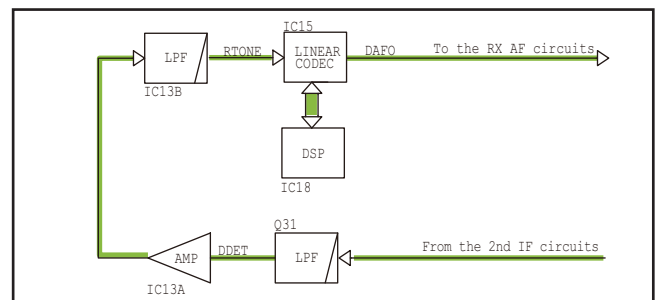

• While operating in the FM/FM-N mode

The demodulated AF signal is passed through the LPF (R272, C355), mode SW (MAIN UNIT: IC8, pins 1, 2) and AF filters (MAIN UNIT: IC9B, pins 6, 7 and IC9C, pins 9, 10), and then applied to the D/A converter (MAIN UNIT: IC11, pin 13) to be adjusted in level.

The level-adjusted AF signal is amplified by the AF power AMP (MAIN UNIT: IC2, pin 1), and then output from the internal speaker (CHASSIS: SP1) or external speaker, through the SP jack (MAIN UNIT: J4).

• RX AF CIRCUITS

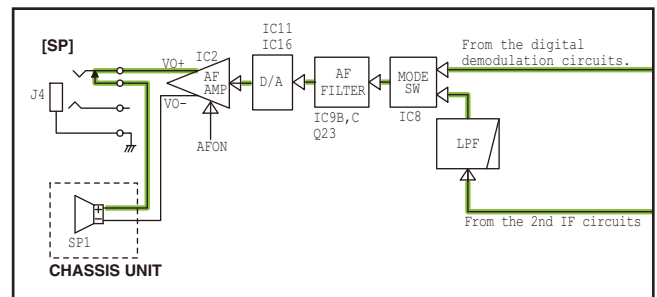

4-2 TRANSMIT CIRCUITS

TX AF CIRCUITS (LOGIC AND MAIN UNITS)

The AF signal from the internal or external microphone (MIC signal) is applied to the MIC AMP (LOGIC UNIT: IC19B, pin 5).

• When operating in the DV mode

The amplified signal is passed through the MIC mute SW (LOGIC UNIT: IC16, pins 1, 7), and then further amplified by the ALC AMP (LOGIC UNIT: IC14, pin 1). The amplified signal is applied to the liner CODEC (LOGIC UNIT: IC15, pin 2), through the buffer (LOGIC UNIT: IC12B, pins 6, 7), to be encoded into a digital audio signal.

The digital audio signal is processed by the DSP (LOGIC UNIT: IC18), and then applied to the linear codec (LOGIC UNIT: IC15) to be converted into the digital baseband signal.

The digital baseband signal is passed through the LPF (LOGIC UNIT: IC12A, pins 1, 3), and then applied to the MAIN UNIT.

The digital baseband signal is passed through the mode SW (MAIN UNIT: IC8, pins 10, 11), and then applied to the D/A converter (MAIN UNIT: IC11, pin 18) to be adjusted in level.

• When operating in the FM/FM-N mode

The amplified signal is passed through the MIC mute SW (LOGIC UNIT: IC16, pins 1, 7), and then applied to the MAIN UNIT.

The MIC signal is passed through the HPF (MAIN UNIT: R78, C77, C80), BPF (MAIN UNIT: IC9A, pins 1, 3), LPF (MAIN UNIT: IC9D, pins 13, 14) and mode SW (MAIN UNIT: IC8, pins 8, 9), and then applied to the D/A converter (MAIN UNIT: IC11, pin 18) to be adjusted in level.

The level-adjusted signal is applied to the modulation circuits.

• TX AF CIRCUITS

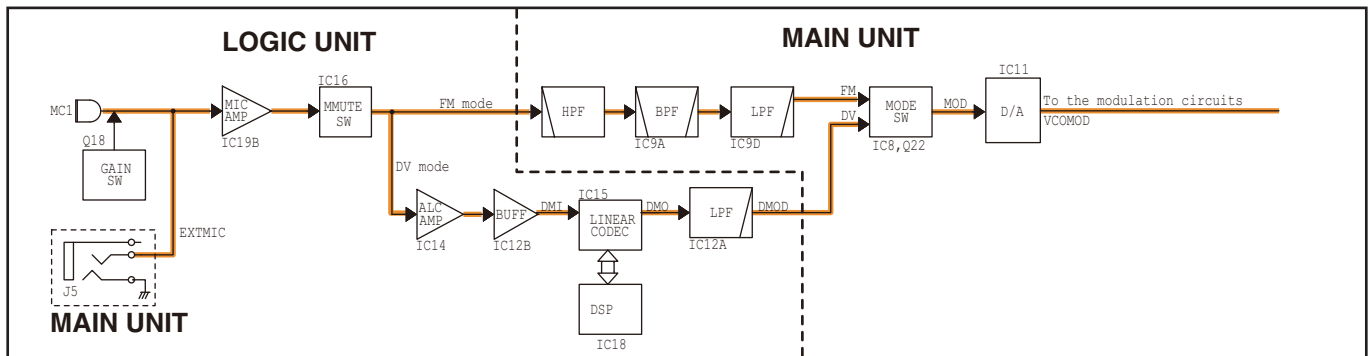

MODULATION CIRCUITS (MAIN UNIT)

The MIC signal from the TX AF circuits is applied to the VCO (Q27, D10–D12) as a modulation signal. The modulation signal is applied to D10 to obtain GMSK (For DV mode) or Frequency Modulation (For FM mode).

The modulated VCO output signal is passed through the buffer (Q30) and amplified by the LO AMP (Q32), and then applied to the TX AMP circuits as the TX signal, through the LO SW (D14).

• MODULATION CIRCUITS

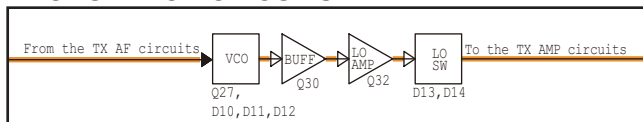

TX AMP CIRCUITS (MAIN UNIT)

The TX signal is passed through the buffer (Q48) and attenuator (D20, D21) which controls the TX output power by the APC AMP (IC14). The TX signal is sequentially amplified by the YGR (Q39) and drive AMP (Q41), and then passed through the LPF (L42, C250, C351). The filtered TX signal is applied to the power AMP (Q45).

The amplified TX signal is passed through the LPF (L22, L24, C260, C265, C267, C270), ANT SW (D24, D25), TX output power detector (D26, D28) and two LPFs (L29, C281, C285 and L32, L34, C302, C303, C306, C307, C312), before being applied to the antenna.

APC CIRCUITS (MAIN UNIT)

The voltage produced at the LPFs (L29, C281, C285 and L32, L34, C302, C303, C306, C307, C312) is rectified by D26 and D28, and it is used as the TX power sensing voltage.

The voltage is applied to the APC AMP (IC14, pin 7), and the output voltage controls the bias voltages of attenuator (D20, D21) to keep the TX output power constant.

• TX AMP AND APC CIRCUITS

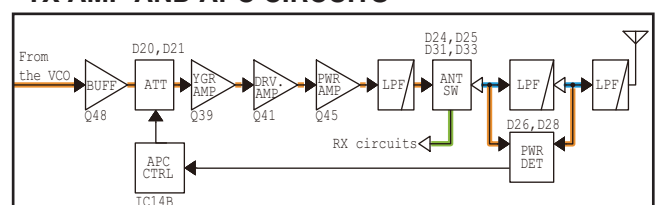

4-3 FREQUENCY SYNTHESIZER (MAIN UNIT)

• VCO

The ID-31A/E has a VCO (Q27, D10–D12) which generates both the 1st LO signal and the TX signal. The output of buffer (Q30) is amplified by the LO AMP (Q32), and then used as the TX/RX LO signal.

While receiving, the LO signal is applied to the 1st IF mixer (Q46), through the LO SW (D13) and LPF (L30, C280, C289).

While transmitting, the LO signal is applied to the TX AMP circuits, through the LO SW (D14), buffer (Q48) and attenuator (D20, D21).

• PLL

A portion of VCO output signal is passed through two buffers (Q29 and Q30) and LPF (L7, C137–C139, C144), and then fed back to the PLL IC (IC6, pin 8).

The PLL IC (IC6) phase-compares the output of reference frequency oscillator (TCXO; X1) and VCO, and the phase-difference is output as the charge pump current. The current is passed through the loop filter (R67, R71, R90, R93, C74, C91, C92, C96, C102) to be converted into the lock voltage, which controls the oscillating frequency of VCO.

When the oscillation frequency drifts, its phase changes from that of the reference frequency, causing a lock voltage change to compensate for the drift in the VCO oscillating frequency.

• FREQUENCY SYNTHESIZER CIRCUITS

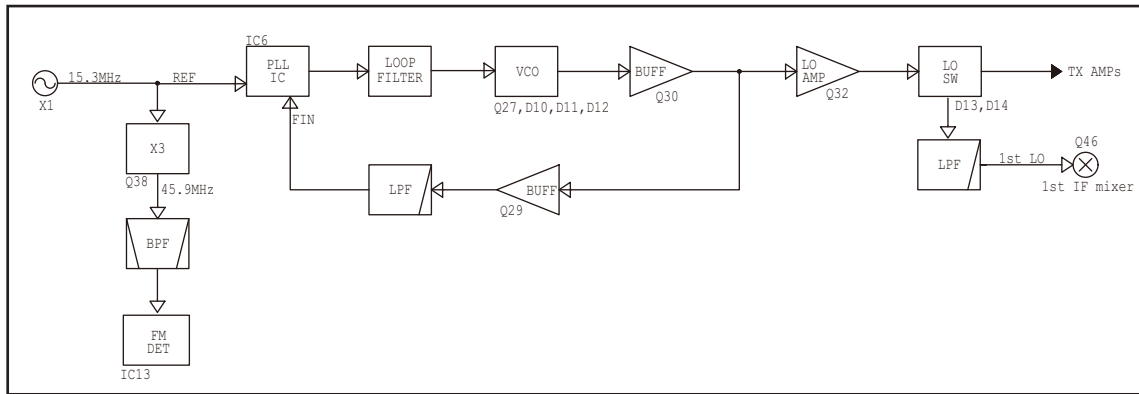

4-4 VOLTAGE DIAGRAM

Voltage from the power supply is routed throughout the transceiver, through regulators and switches.

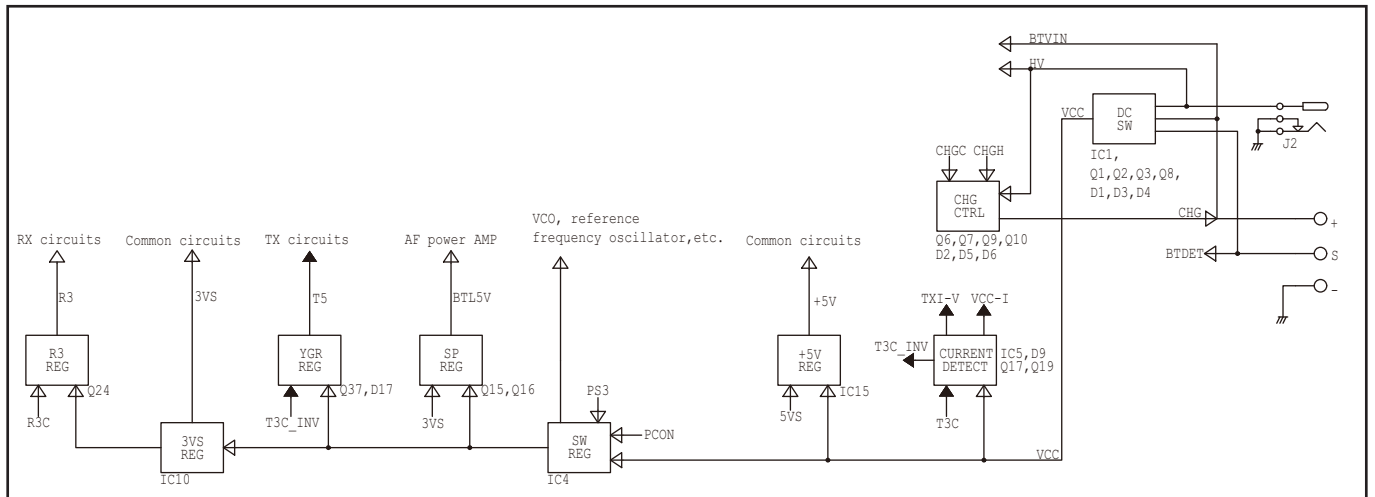

4-5 PORT ALLOCATIONS

• CPU (LOGIC UNIT: IC5)

BALL No.	LINE NAME	DESCRIPTION	I/O
A4	G_RES	GPS module (CHASSIS: EP1) controller (IC1) reset. L: Reset.	O
A5	REMOTE	HM-75A key input detect.	I
A6	VIN	External power supply voltage.	I
A7	RTONE	DV signal/recorded audio.	I
A8	TTEMP	TX AMP (MAIN UNIT: Q45) temperature sensing voltage.	I
A10	DICK1	[DIAL] (outer dial) (S12) phase-A	I
A11	UNLK	PLL unlock detect. L: Unlock is detected.	I
A12	DALD	D/A converter (MAIN UNIT: IC11) strobe. ("H" and "L" are reversed.)	O
A13, A14	KS0, KS2	Key matrix ports.	O
B1	DTMF	DTMF/European tone/Beep signal.	O
B5	LV	Lock voltage.	I
B7	TXI-V	TX current flow sensing voltage.	I
B8	TEMP	Temperature sensing voltage.	I
B10	DIUD1	[DIAL] (outer dial) (S12) phase-B	I
B11	CLSFT	CPU clock frequency control. H: The clock frequency is shifted.	O
B13	KS1	Key matrix port.	O
B15	KR0	Key input detect.	I
C2	CTCSS	CTCSS/DTCS tone signal.	O
C5	VOX	VOX sensing voltage.	I
C7	CTCIN	CTCSS tone signal input.	I
C10	DIUD2	[DIAL] (inner dial) (S12) phase-B.	I
C11	DTCS	CTCSS/DTCS filter (R65, R68, C78, C80) switching. H: DTCS is in use.	O
C13	KS3	Key matrix port.	O
C14	KR1	Key input detect.	I
C15	DCIN	External power supply connection detect. L: External DC input.	I
D1	DADATA	D/A converter serial data. ("H" and "L" are reversed.)	O
D2	G_RXD	GPS data input.	I
D4	DCSFT	DSP clock frequency control. L: Clock frequency is shifted.	O
D5	BTSENC	Battery type detect. (Detecting intermediate voltage of the battery pack.)	I
D6	BTVIN	Battery pack voltage.	I
D7	RSSI	S-meter voltage.	I
D10	DICK2	[DIAL] (inner dial) (S12) phase-A.	I
D11	DACK	D/A converter (MAIN UNIT: IC11) clock. ("H" and "L" are reversed.)	O
D12	KR2	Key input detect.	I
D13	BTDET	Battery attachment detect. L: Battery attached.	I
D14	PWRSW	[POWER] key. L: Pushed.	I
E4	G_TXD	GPS data output.	O
F12	CHGC	Charging ON/OFF control. H: While charging.	O
F13	TXLED	TX LED (DS7) driver (Q9) control. H: While transmitting.	O
F15	BLED	BUSY LED (DS7) driver (Q8) control. H: While the squelch is open.	O
G1	RESET	CPU reset. L: Reset.	I

BALL No.	LINE NAME	DESCRIPTION	I/O		
G3	LIGHT	LCD and key backlight (DS1, DS3) driver (Q23) control.	O		
G4	DIM	LCD backlight (DS1, DS3) dimmer control. H: Blight.	O		
G12	INTMIC	Internal MIC (MAIN UNIT: MC1) control. H: Internal microphone is in use.	O		
G14	CHGH	Charging current control. H: While charging.	O		
G15	PCON	Power lines "PS3" and "5VS" SW (MAIN UNIT: IC4) control. H: While the transceiver's power is ON.	O		
H12	VCO_SEL	VCO power supply control. L: While the transceiver's power is ON.	O		
J4	RTC_IRQ	Real time clock "IRQ" input.	I		
J12	MMUTE	MIC mute SW (IC16) control. L: Mute.	O		
J13	TXMUTE	TX mute SW (MAIN UNIT: Q43) control. H: mute.	O		
J15	PFMC	GPS/DSP operating mode control.	O		
K1	NOIS	Noise level sensing voltage.	I		
K4	DSP_REQ	DSP "REQ" input.	I		
K12	VCO_MUTE	Modulation mute SW (MAIN UNIT: Q21) control. H: Mute.	O		
K13	WN	2nd IF filter (MAIN UNIT: F11 and F12) switching control. L: F11 is selected. (While in the FM-N or DV mode.)	O		
K14	MIC1	MIC gain control.	O		
K15	MIC2	MIC1		MIC2	MIC gain level
		L		L	4
K15	MIC2	H		L	3
		L	H	2	
K15	MIC2	H	H	1	
L12	SQL	[SQL] (MAIN UNIT: S1) input. L: Pushed.	I		
L14	PS3C	Power line "PS3C" SW (Q13) control. L: While in the power save mode.	O		
L15	R3C	Power line "R3C" SW (MAIN UNIT: Q24) control. L: While receiving.	O		
M2	CLOUT	Cloning data.	O		
M5	DSP_STB	DSP (IC18) strobe.	O		
M6	DSPC	Power line "CVDD_1.35V" SW (IC10) control. H: While the DSP's power is ON.	O		
M7	PPS	PLL operating mode control. H: While in the power save mode.	O		
M8	LCDRS	LCD (DS10) reset.	O		
M9	LCDCS	LCD (DS10) chip select.	O		
M10	DSP_REMP	DSP "REC EMP" input.	I		
M12	TX232	RS-232C serial data output.	O		
M14	ESIO	EEPROM (IC7) serial data.	I/O		
M15	T3C	Power line "T3C" SW (MAIN UNIT: Q17, Q19) control. H: While transmitting.	O		
N1	CLIN	Cloning data.	I		
N2	SD_SENC	SD Card insertion detect. L: A microSD card is inserted.	I		
N3	SD_TXD	MicroSD card data output.	O		

• CPU (LOGIC UNIT: IC5) (Continued)

BALL No.	LINE NAME	DESCRIPTION	I/O
N4	DSP_SI	DSP (IC10) serial data.	I
N5	DSP_AFC1	DSP (IC10) "AFC" input.	I
N6	RTC_SDA	Serial data to the real time clock (IC4).	I/O
N7	PLLSTB	PLL IC (MAIN UNIT: IC6) strobe.	O
N9	LCDDT	LCD (DS10) serial data.	O
N10	DSP_DEMP	DSP (IC18) "DATA EMP" input.	I
N12	G_HIB	GPS module (CHASSIS: EP1) controller (IC1) power control. H: GPS module is ON.	O
N15	ECK	EEPROM (IC7) clock.	O
P1	SD_CS	MicroSD card chip select.	O
P2	SD_SCK	MicroSD card clock output.	O
P4	DSP_CK	DSP (IC18) clock.	O
P5	DSP_PD	DSP (IC18) operating mode control. H: While in the power save mode.	O
P6	LCDRES	LCD (DS10) reset.	O
P7	PLLDATA	PLL IC (MAIN UNIT: IC6) serial data.	O
P9	PLL SW	PLL lockup time control. L: Fast lockup time.	O
P12	GPSC	GPS module (CHASSIS: EP1) controller (IC1) switching. H: GPS module's power is ON.	O
P13	RX232	RS-232C serial data input.	I
P14	INTPTT	Internal PTT (MAIN UNIT: S2) input. L: Pushed.	I
R1	SD_RXD	MicroSD card card data input.	I
R2	DSP_SO	DSP (IC18) serial data.	O
R4	DSP_AFC2	DSP (IC18) "AFC" input.	I
R5	DSP_RESET	DSP (IC18) reset. H: Reset.	O
R6	RTC_SCL	Clock signal to the real time clock IC (IC4).	O
R7	PLLCK	PLL IC (MAIN UNIT: IC6) clock.	O
R8	LCDCK	LCD (DS10) clock.	O
R13	AFON	AF power AMP (MAIN UNIT: IC2) control. L: AF power AMP activated.	O
R14	EXTPTT	External PTT input.	I

• D/A CONVERTER (MAIN UNIT: IC11)

PIN No.	LINE NAME	DESCRIPTION	I/O
7	BPF1	Tuning voltage to the BPF (D32, L40, C353).	O
8	BPF3	Tuning voltage to the BPF (D27, D29, D30, L28, L31, L33, C286, C290, C292, C293, C297, C299–C301, C304, C305).	O
11	SQLOUT	Noise squelch level adjustment.	O
12	RXAFOUT	RX AF output level adjustment.	O
19	VCOMOD	VCO (Q27, D10–D12) deviation adjustment.	O
20	REFMOD	Reference oscillator (X1) deviation adjustment.	O
24	BPF2	Tuning voltage to the BPF (D27, D29, D30, L28, L31, L33, C286, C290, C292, C293, C297, C299–C301, C304, C305).	O

SECTION 5 ADJUSTMENT PROCEDURE

5-1 PREPARATION

REQUIRED EQUIPMENTS

EQUIPMENT	GRADE AND RANGE	EQUIPMENT	GRADE AND RANGE
Power supply	Voltage range : 1–15 V Current capacity : More than 3 A	JIG cable	Modified 3-conductor plugs (See the illustration below)
Audio generator (AG)	Frequency range : 300–3000 Hz Output level : 1–500 mV	Attenuator	Power attenuation : 40 dB Capacity : More than 6 W
Modulation Analyzer	Frequency range : 30–600 MHz Measuring range : 0 to ± 10 kHz	Standard signal generator (SSG)	Frequency range : 0.1–600 MHz Output level : -20 dB μ to 90 dB μ (-127 to -17 dBm)
AC millivoltmeter	Measuring range : 10 mV to 10 V	Frequency counter	Frequency range : 0.1–600 MHz Frequency accuracy : ± 1 ppm or better Input level : Less than 1 mW
RF power meter (50 Ω terminated)	Measuring range : 0.1–6 W Frequency range : 100–600 MHz SWR : Less than 1.2 : 1		

JIG CABLES

JIG cable #1

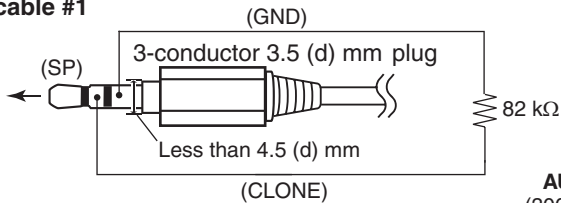

JIG cable #2

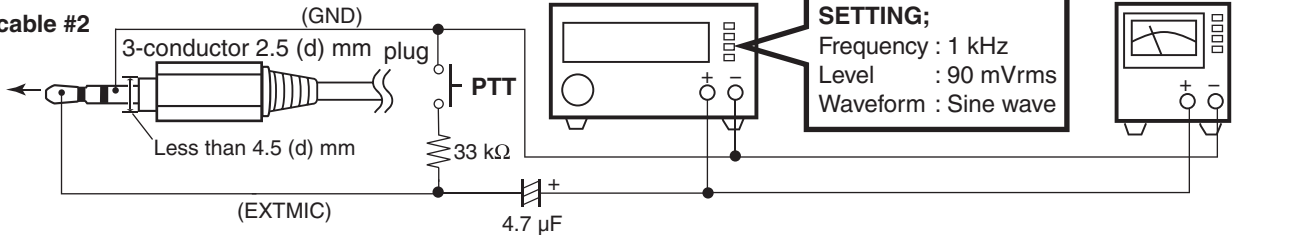

CONNECTION

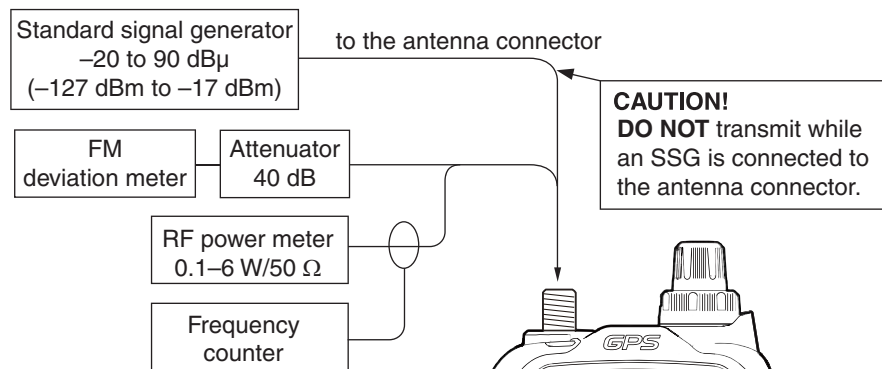

POWER SUPPLY CONNECTION

Adjustment at 13.5 V

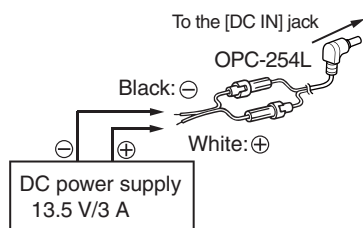

Adjustment at 5.5 V or 7.4 V

Be sure about the polarity

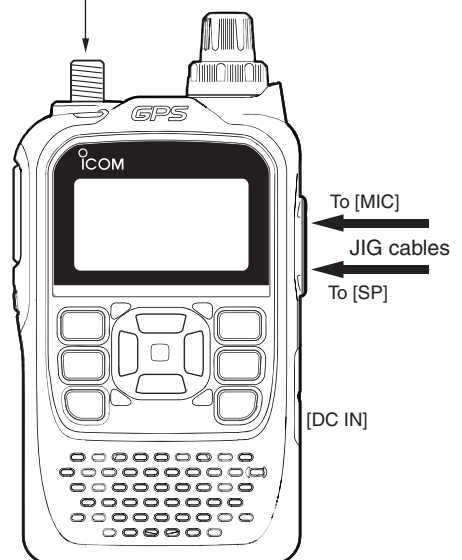
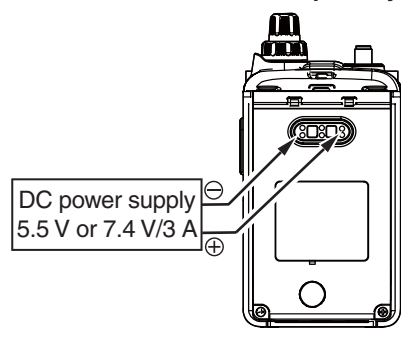

• ENTERING THE ADJUSTMENT MODE

- 1) Connect the JIG cable "#1" (See page 5-1) to [SP].
- 2) While holding down [SQL] and , turn ON the power.

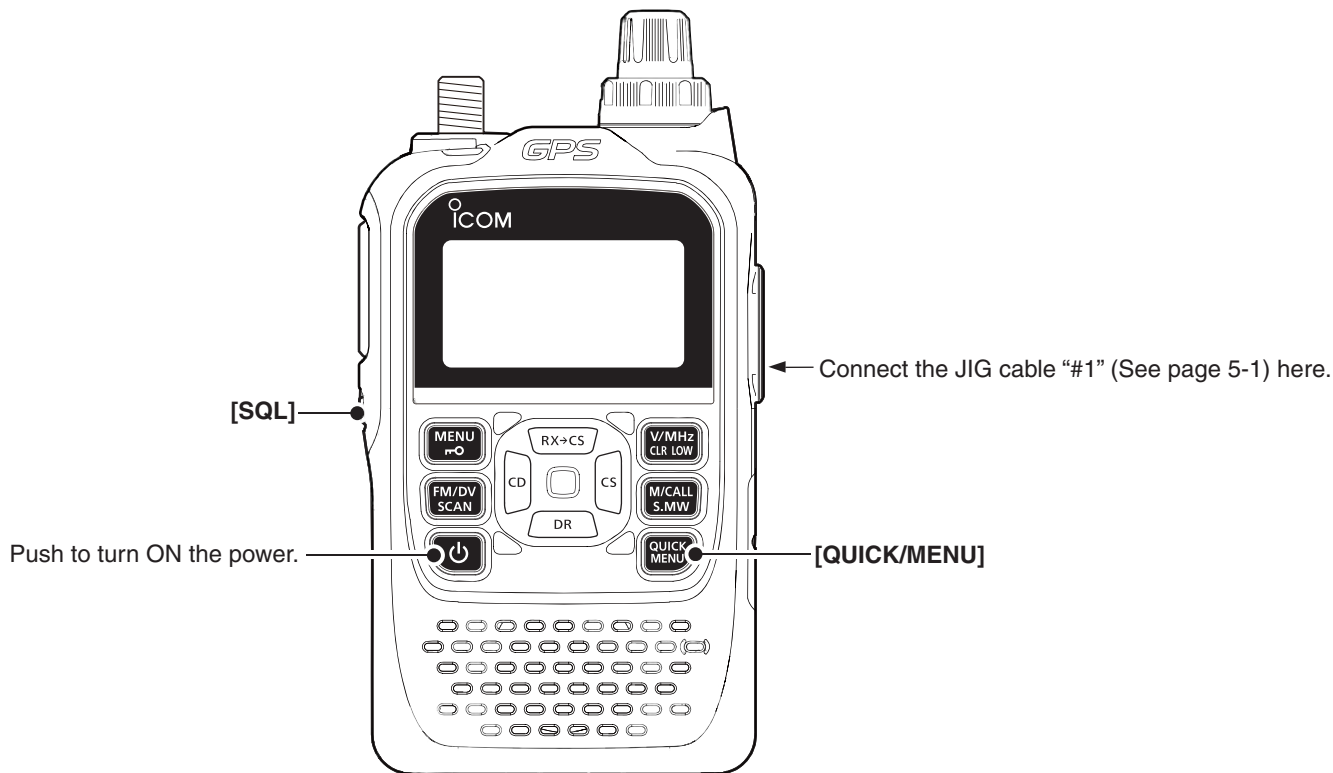

• KEY ASSIGNMENTS FOR THE ADJUSTMENT MODE



• QUITTING THE ADJUSTMENT MODE

- 1) Remove the JIG cable "#1" from [SP].
- 2) Turn OFF the power, and then turn ON the power.

5-2 FREQUENCY ADJUSTMENT

Select an adjustment item using RX+CS / DR , and then set the adjustment value as specified using **[DIAL]**.

ADJUSTMENT	ADJUSTMENT ITEM	OPERATION		VALUE
REFERENCE FREQUENCY	[REF]	1	1) Set the power supply voltage to 7.4 V. 2) Connect a power meter or dummy load to the antenna connector. 3) Loosely couple a frequency counter to the antenna connector. 4) While transmitting, adjust the frequency using [DIAL] , and then push [ENT] to store the adjustment value.	Displayed frequency (± 200 Hz)

5-3 TRANSMIT ADJUSTMENT

• IDLING CURRENT ADJUSTMENT (at 5.5 V)

Select an adjustment item using RX+CS / DR , and then set the adjustment value as specified using **[DIAL]**.

ADJUSTMENT	ADJUSTMENT ITEM	OPERATION		VALUE
DRIVE AMP IDLING CURRENT	[ID5]	1	1) Set the power supply voltage to 5.5 V. 2) Connect an RF power meter to the antenna connector. 3) Connect a ammeter between the power supply and transceiver. 4) Set the item [IP5] to "00."	–
		2	• While transmitting, adjust the idling current using [DIAL] , and then push [ENT] to store the adjustment value.	120–140 mA
FINAL AMP IDLING CURRENT	[IP5]	1	1) Set the power supply voltage to 5.5 V. 2) Connect an RF power meter to the antenna connector. 3) Connect a ammeter between the power supply and transceiver.	–
		2	• While transmitting, adjust the idling current using [DIAL] , and then push [ENT] to store the adjustment value.	180–280 mA

• IDLING CURRENT ADJUSTMENT (at 7.4 V)

Select an adjustment item using RX+CS / DR , and then set the adjustment value as specified using **[DIAL]**.

ADJUSTMENT	ADJUSTMENT ITEM	OPERATION		VALUE
DRIVE AMP IDLING CURRENT	[ID7]	1	1) Set the power supply voltage to 7.4 V. 2) Connect an RF power meter to the antenna connector. 3) Connect a ammeter between the power supply and transceiver. 4) Set the item [IP7] to "00."	–
(Hi power)		2	• While transmitting, adjust the idling current using [DIAL] , and then push [ENT] to store the adjustment value.	170–190 mA
(Mid power)		3		120–140 mA
(Low power)		4		100–120 mA
(S-Low power)		5		
FINAL AMP IDLING CURRENT	[IP7]	1	1) Set the power supply voltage to 7.4 V. 2) Connect an RF power meter to the antenna connector. 3) Connect a ammeter between the power supply and transceiver.	–
(Hi power)		2	• While transmitting, adjust the idling current using [DIAL] , and then push [ENT] to store the adjustment value.	880–980 mA
(Mid power)		3		480–580 mA
(Low power)		4		160–260 mA
(S-Low power)		5		

NOTE: When "IDLING CURRENT" is adjusted, "TRANSMIT POWER" must be also re-adjusted.

5-3 TRANSMIT ADJUSTMENT (Continued)

• IDLING CURRENT ADJUSTMENT (at 13.5 V)

Select an adjustment item using **[RX+CS]**/**[DR]**, and then set the adjustment value as specified using **[DIAL]**.

ADJUSTMENT	ADJUSTMENT ITEM	OPERATION		VALUE
DRIVE AMP IDLING CURRENT	[ID1]	1	1) Set the power supply voltage to 13.5 V. (supplying from [DC IN]) 2) Connect an RF power meter to the antenna connector. 3) Connect an ammeter between the power supply and transceiver. 4) Set the item [IP1] to "00."	–
(Hi power)		2	• While transmitting, adjust the idling current using [DIAL] , and then push [ENT] to store the adjustment value.	100–120 mA
(Mid power)		3		90–110 mA
(Low power)		4		80–100 mA
(S-Low power)		5		
FINAL AMP IDLING CURRENT	[IP1]	1	1) Set the power supply voltage to 13.5 V. (supplying from [DC IN]) 2) Connect an RF power meter to the antenna connector. 3) Connect an ammeter between the power supply and transceiver.	–
(Hi power)		2	• While transmitting, adjust the idling current using [DIAL] , and then push [ENT] to store the adjustment value.	550–670 mA
(Mid power)		3		350–450 mA
(Low power)		4		140–240 mA
(S-Low power)		5		

NOTE: When "IDLING CURRENT" is adjusted, "TRANSMIT POWER" must be also re-adjusted.

• TRANSMIT POWER ADJUSTMENT (at 5.5 V)

Select an adjustment item using **[RX+CS]**/**[DR]**, and then set the adjustment value as specified using **[DIAL]**.

ADJUSTMENT	ADJUSTMENT ITEM	OPERATION		VALUE
TRANSMIT POWER	[PO5]	1	1) Set the power supply voltage to 5.5 V. 2) Connect an RF power meter to the antenna connector.	80–120 mW
(BAND LOW)		2	3) While transmitting, adjust the TX power using [DIAL] , and then push [ENT] to store the adjustment value.	
(BAND HIGH)		3		

NOTE: When "IDLING CURRENT" is adjusted, "TRANSMIT POWER" must be also re-adjusted.

• TRANSMIT POWER ADJUSTMENT (at 7.4 V)

Select an adjustment item using **[RX+CS]**/**[DR]**, and then set the adjustment value as specified using **[DIAL]**.

ADJUSTMENT	ADJUSTMENT ITEM	OPERATION		VALUE
TRANSMIT POWER	[PO7]	1	1) Set the power supply voltage to 7.4 V. 2) Connect an RF power meter to the antenna connector.	–
(Hi power) [BAND LOW] [BAND HIGH]		2	• While transmitting, adjust the TX power using [DIAL] , and then push [ENT] to store the adjustment value.	4.8–5.2 W
(Mid power) [BAND LOW] [BAND HIGH]		3		2.3–2.7 W
(Low power) [BAND LOW] [BAND HIGH]		4		0.4–0.6 W
(S-Low power) [BAND LOW] [BAND HIGH]		5		80–120 mW

5-3 TRANSMIT ADJUSTMENT (Continued)

• TRANSMIT POWER ADJUSTMENT (at 13.5 V)

Select an adjustment item using $\overline{\text{RX+CS}}$ / $\overline{\text{DR}}$, and then set the adjustment value as specified using **[DIAL]**.

ADJUSTMENT	ADJUSTMENT ITEM	OPERATION		VALUE
TRANSMIT POWER	—	1	1) Set the power supply voltage to 13.5 V. (supplying from [DC IN]) 2) Connect an RF power meter to the antenna connector.	—
(Hi power) [BAND LOW]	[PO1]	2	• While transmitting, adjust the TX power using [DIAL] , and then push [ENT] to store the adjustment value.	4.8–5.2 W
[BAND HIGH]		3		
(Mid power) [BAND LOW]		4		
[BAND HIGH]		5		2.3–2.7 W
(Low power) [BAND LOW]		6		
[BAND HIGH]		7		
(S-Low power) [BAND LOW]		8		0.4–0.6 W
[BAND HIGH]		9		

• DEVIATION ADJUSTMENTS

Select an adjustment item using $\overline{\text{RX+CS}}$ / $\overline{\text{DR}}$, and then set the adjustment value as specified using **[DIAL]**.

ADJUSTMENT	ADJUSTMENT ITEM	OPERATION		VALUE
FM DEVIATION	—	1	1) Set the power supply voltage to 7.4 V. 2) Connect a modulation analyzer to the antenna connector through an attenuator, and set it as; HPF : OFF LPF : 20 kHz De-emphasis : OFF Detector : (P-P)/2 3) Connect an audio generator to the JIG cable (See page 5-1).	—
[FM (BAND LOW)]	[MFL]	2	1) Set the audio generator as; Frequency : 1 kHz Level : 90 mVrms 2) While transmitting, adjust the deviation using [DIAL] , and then push [ENT] to store the adjustment value.	±4.1 to ±4.3 kHz
[FM-N (BAND HIGH)]	[MNL]	3		±2.0 to ±2.2 kHz
[FM (BAND LOW)]	[MFH]	4		±4.1 to ±4.3 kHz
[FM-N (BAND HIGH)]	[MNH]	5		±2.0 to ±2.2 kHz
REF DEVIATION [FM (BAND LOW)]	[BFL]	1		1) Set the audio generator as; Level : 0 mVrms (OFF) 2) While transmitting, adjust the deviation using [DIAL] , and then push [ENT] to store the adjustment value.
[FM-N (BAND HIGH)]	[BNL]	2		
[FM (BAND LOW)]	[BFH]	3		
[FM-N (BAND HIGH)]	[BNH]	4		
DV DEVIATION	—	1	1) Set the power supply voltage to 7.4 V. 2) Connect a modulation analyzer to the antenna connector through an attenuator, and then set it as; HPF : OFF LPF : 20 kHz De-emphasis : OFF Detector : (P-P)/2 3) No audio signal is applied.	—
[BAND LOW]	[DVV]	2	• While transmitting, adjust the deviation using [DIAL] , and then push [ENT] to store the adjustment value.	±0.95 to ±1.15 kHz
[BAND CENTER]		3		
[BAND HIGH]		4		
DV BALANCE	—	1	1) Set the power supply voltage to 7.4 V. 2) Connect a modulation analyzer to the antenna connector through an attenuator, and then set it as; HPF : OFF LPF : 20 kHz De-emphasis : OFF Detector : (P-P)/2 3) No audio signal is applied.	—
[BAND LOW]	[DVR]	2	• While transmitting, adjust the deviation using [DIAL] , and then push [ENT] to store the adjustment value.	Minimum deviation
[BAND CENTER]		3		
[BAND HIGH]		4		

5-3 TRANSMIT ADJUSTMENT (Continued)

• TONE DEVIATION ADJUSTMENTS

Select an adjustment item using $\overline{\text{RX+CS}}$ / $\overline{\text{DR}}$, and then set the adjustment value as specified using **[DIAL]**.

ADJUSTMENT	ADJUSTMENT ITEM	OPERATION	VALUE
TONE DEVIATION	-	1) Set the power supply voltage to 7.4 V. 2) Connect a modulation analyzer to the antenna connector through an attenuator, and then set it as; HPF : OFF LPF : 20 kHz De-emphasis : OFF Detector : (P-P)/2 3) No audio signal is applied.	-
[DTCS] (FM)	[MDT]	2 • While transmitting, adjust the deviation using [DIAL] , and then push [ENT] to store the adjustment value.	±0.7 to ±0.8 kHz
(FM-N)			±0.325 to ±0.425 kHz
[CTCSS] (FM)	[MCT]	3	±0.7 to ±0.8 kHz
(FM-N)			±0.325 to ±0.425 kHz
[DTMF] (FM)	[MDM]	4	±3.4 to ±3.6 kHz
(FM-N)			±1.65 to ±1.85 kHz
[EURO TONE] (FM)	[MET]	5	±3.4 to ±3.6 kHz
(FM-N)			±1.65 to ±1.85 kHz

5-4 RECEIVE ADJUSTMENTS

1) Select an adjustment item (band) using RX+CS / DR .

2) Set the SSG as specified (frequency, deviation and output level), and then push O to automatically adjust.

ADJUSTMENT	ADJUSTMENT ITEM	OPERATION	VALUE
RECEIVE SENSITIVITY	NOTE: "RECEIVE SENSITIVITY" must be adjusted before "S-METER." Otherwise, "S-METER" will not be adjusted properly.		
	-	1) Set the power supply voltage to 7.4 V. 2) Connect an SSG to the antenna connector, and then set it as;	Push O . (Automatic adjustment)
400.02 MHz	[UTL]	2 Frequency : (Displayed on the function display)	
435.02 MHz	[UTM]	3 Level : -10 dB μ (-117 dBm) [†]	
478.95 MHz	[UTH]	4 Modulation : 1 kHz Deviation : 3.5 kHz	
S-METER	NOTE: "RECEIVE SENSITIVITY" must be adjusted before "S-METER" and "S-METER S3 LEVEL." Otherwise, "S-METER" and "S-METER S3 LEVEL" will not be adjusted properly.		
	-	1) Set the power supply voltage to 7.4 V. 2) Connect an SSG to the antenna connector and set it as; Modulation : 1 kHz Deviation : 3.5 kHz	-
S0 level	[USO]	2 • Set the SSG as; Frequency : (Displayed on the function display) Level : -10 dB μ (-117 dBm) [†]	Push O . (Automatic adjustment)
S3 level	[US3]	3 • Set the SSG as; Level : -6 dB μ (-113 dBm) [†]	
Full scale	[USF]	4 • Set the SSG as; Level : +10 dB μ (-97 dBm) [†]	
SQUELCH		1) Set the power supply voltage to 7.4 V. 2) Connect an SSG to the antenna connector and set as; Modulation : 1 kHz Deviation : 1.75 kHz	-
[FM]	[SQL]	2 • Set the SSG as; Frequency : (Displayed on the function display) Level : OFF [†]	Push O . (Automatic adjustment)
[FM-N]		3 • Set the SSG as; Frequency : (Displayed on the function display) Level : -24 dB μ (-131 dBm) [†]	

[†]; This output level of a standard signal generator (SSG) is indicated as SSG's open circuit.

SECTION 6

PARTS LIST

[MAIN UNIT]

REF NO.	PARTS NO.	DESCRIPTION	M.	H/V LOCATION
IC1	1110007860	S.IC S-80950CLPF-G7LTFG	B	19.2/31.95
IC2	1110007610	S.IC TPA0211DGNR	B	36.3/39.5
IC3	1180003800	S.REG NJU7775F04-TE2-#ZZZB	B	31.6/32.6
IC4	6910022360	S.DC TPS62110RSAR	B	81.8/12.7
IC5	1110006380	S.IC LM2904PWR	B	17.8/14.8
IC6	1130011671	S.IC MB15E03SLPFV1-G-ER-6E1	B	51.25/6.95
IC8	1130015760	S.IC TC74VHC0466AFK(EK)	B	61.6/26.4
IC9	1110006470	S.IC LMV3241PWR	T	64.0/25.5
IC10	1180003760	S.REG TLV70033DDCR	T	71.3/18.2
IC11	1110007550	S.IC R2A20178NP	T	61.3/17.0
IC12	1110002751	S.IC TA75S01F(TE85RF)	B	37.8/6.7
IC13	1110007320	S.IC NJM2591V-TE1-#ZZZB	B	53.3/32.9
IC14	1110006380	S.IC LM2904PWR	B	35.0/15.7
IC15	1180003460	S.REG NJM2831F05-TE1-#ZZZB	T	65.9/10.2
IC16	1110006490	S.IC LMV321IDCKR	T	70.7/13.5
Q1	1590004100	S.TRA LDTC144TET1G <SLVJ>	T	20.6/26.1
Q2	1550000240	S.FET TPCF8107(TE85LF)	T	15.9/20.8
Q3	1590004100	S.TRA LDTC144TET1G <SLVJ>	T	21.4/23.8
Q6	1520000651	S.TRA 2SB1201S-TL-E	B	41.4/42.6
Q7	1590004410	S.TRA DMC501010R	T	43.4/43.9
Q8	1550000240	S.FET TPCF8107(TE85LF)	T	18.7/18.8
Q9	1510001100	S.TRA 2SA1832-GR(TE85RF)	B	45.4/42.6
Q10	1590004070	S.TRA LDTC144EET1G <SLVJ>	B	45.6/38.0
Q12	1530003990	S.TRA 2SC4738-BL(TE85LF)	T	47.4/14.1
Q14	1510001100	S.TRA 2SA1832-GR(TE85RF)	T	45.7/16.7
Q15	1590004410	S.TRA DMC501010R	T	76.9/33.1
Q16	1520000450	S.TRA 2SB1132 T100 Q	B	75.7/33.6
Eqv.	1520000910	S.TRA 2SB1132L-R-AB3-R <SLVJ>		
Q17	1510001100	S.TRA 2SA1832-GR(TE85RF)	T	15.3/15.1
Q19	1590004070	S.TRA LDTC144EET1G <SLVJ>	T	24.6/24.6
Q21	1590004070	S.TRA LDTC144EET1G <SLVJ>	B	60.7/18.5
Q22	1590004070	S.TRA LDTC144EET1G <SLVJ>	B	59.4/23.0
Q23	1590004060	S.TRA LDTC144EET1G <SLVJ>	T	57.5/24.1
Q24	1510001100	S.TRA 2SA1832-GR(TE85RF)	T	11.5/34.9
Q26	1560000541	S.FET 2SK880-Y(T5RICOMF)	T	50.7/17.7
Q27	1530003260	S.FET 2SC5006-T1	B	46.7/23.4
Q29	1530003260	S.TRA 2SC5006-T1	B	48.0/13.3
Q30	1530003260	S.TRA 2SC5006-T1	B	42.5/14.3
Q31	1590004390	S.TRA DMG500410R	B	67.9/35.0
Q32	1530003810	S.TRA 2SC5008-T1	B	40.5/18.1
Q33	1590004070	S.TRA LDTC144EET1G <SLVJ>	T	66.2/18.2
Q34	1590004070	S.TRA LDTC144EET1G <SLVJ>	T	66.2/16.2
Q35	1590004070	S.TRA LDTC144EET1G <SLVJ>	T	66.2/14.2
Q36	1590004300	S.TRA DRA9114TOL	T	54.1/39.8
Q37	1510001100	S.TRA 2SA1832-GR(TE85RF)	T	27.9/21.4
Q38	1530003990	S.TRA 2SC4738-BL(TE85LF)	T	55.7/20.8
Q39	1530003920	S.TRA 2SC5998YC-TL-E	T	42.3/9.2
Q40	1530003990	S.TRA 2SC4738-BL(TE85LF)	T	56.9/36.9
Q41	1560001710	S.FET RFM01U7P(TE12LF)	T	33.8/7.2
Q43	1590004070	S.TRA LDTC144EET1G <SLVJ>	T	32.9/23.5
Q44	1530002921	S.TRA 2SC422E-T1 Y25 (R25)	B	48.3/31.7
Q45	1560001720	S.FET RFM12U7X(T2LICOMQ)	T	28.0/12.2
Q46	1580000830	S.FET BB506CFS-TL-E	B	25.6/30.4
Q47	1580000830	S.FET BB506CFS-TL-E	B	6.5/32.0
Q48	1530003260	S.TRA 2SC5006-T1	T	39.3/20.7
Q49	1530003990	S.TRA 2SC4738-BL(TE85LF)	T	28.9/29.3
Q50	1530003990	S.TRA 2SC4738-BL(TE85LF)	T	35.8/28.7
D1	1750002170	S.DIO DB2S31400L	T	18.2/22.6
D2	1790000671	S.DIO SB07-03C-TB-E	T	10.2/27.8
Eqv.	1750002360	S.DIO RB400D T146		
D3	1750001810	S.DIO L1SS400T1G <SLVJ>	T	21.5/21.4
D4	1750001690	S.DIO RB050LA-40	B	50.4/42.5
D5	1750001810	S.DIO L1SS400T1G <SLVJ>	B	47.7/44.2
D6	1750001810	S.DIO L1SS400T1G <SLVJ>	B	47.7/45.4
D9	1730002890	S.ZEN DZZJ033MOL	T	2.8/21.0
D10	1750001610	S.VAR HVC365TRF-E	B	51.3/19.7
D11	1750000721	S.VAR HVC375BTRF-E	B	52.5/19.7
D12	1750000711	S.VAR HVC350BTRF-E	B	50.7/17.5
D13	1750001910	S.DIO HVD144AKRF-E	B	41.5/24.2
D14	1750001910	S.DIO HVD144AKRF-E	B	41.5/23.2
D15	1750001790	S.DIO 1SS390 TE61	T	40.0/34.2
Eqv.	1750002480	S.DIO 1SS390 <KMC>		
Eqv.	1750000571	S.DIO 1SS381 (TPH3F)		
Eqv.	1750001700	S.DIO HSC277TRF-E		
D16	1750001790	S.DIO 1SS390 TE61	T	39.9/30.8
Eqv.	1750002480	S.DIO 1SS390 <KMC>		
Eqv.	1750000571	S.DIO 1SS381 (TPH3F)		
Eqv.	1750001700	S.DIO HSC277TRF-E		
D17	1750001810	S.DIO L1SS400T1G <SLVJ>	T	25.4/22.9
D18	1750001790	S.DIO 1SS390 TE61	T	49.2/41.6
Eqv.	1750002480	S.DIO 1SS390 <KMC>		
Eqv.	1750000571	S.DIO 1SS381 (TPH3F)		
Eqv.	1750001700	S.DIO HSC277TRF-E		
D19	1750001790	S.DIO 1SS390 TE61	T	51.3/40.1
Eqv.	1750002480	S.DIO 1SS390 <KMC>		
Eqv.	1750000571	S.DIO 1SS381 (TPH3F)		
Eqv.	1750001700	S.DIO HSC277TRF-E		
D20	1750002290	S.DIO RKP300KJ	T	41.5/15.7
D21	1750002290	S.DIO RKP300KJ	T	41.5/13.1
D22	1750001820	S.DIO LRB706F-40T1G <SLVJ>	B	47.6/28.7
D23	1750001820	S.DIO LRB706F-40T1G <SLVJ>	B	45.1/28.7
D24	1750001910	S.DIO HVD144AKRF-E	B	20.6/8.0
D25	1750001910	S.DIO HVD144AKRF-E	B	20.6/7.0
D26	1750001820	S.DIO LRB706F-40T1G <SLVJ>	T	18.6/9.9

Eqv.= This component is equivalent to the REF No. component listed above, and may be substituted on parts orders and repairs.

[MAIN UNIT]

REF NO.	PARTS NO.	DESCRIPTION	M.	H/V LOCATION
D27	1750000711	S.VAR HVC350BTRF-E	B	17.6/39.7
D28	1750001820	S.DIO LRB706F-40T1G <SLVJ>	T	13.2/10.0
D29	1750000711	S.VAR HVC350BTRF-E	B	14.2/41.6
D30	1750000711	S.VAR HVC350BTRF-E	B	11.5/41.3
D31	1750001910	S.DIO HVD144AKRF-E	B	18.4/11.6
D32	1750000711	S.VAR HVC350BTRF-E	B	6.8/22.1
D33	1750001910	S.DIO HVD144AKRF-E	B	6.5/18.6
D34	1750002020	S.DIO DA2S10100L	T	31.3/29.8
D36	1750002020	S.DIO DA2S10100L	B	6.4/25.6
D37	1790001830	S.VAR AVR-M1005C270MTAAB	T	20.6/15.2
F11	2020002180	S.CER CFWKA450KHFA-R0	T	46.8/34.8
F12	2020002480	S.CER LTWC450E1 <CJE>	T	46.8/25.7
F13	2030000860	S.MON MFT46.3M 46.350 MHz (FL-439)	B	39.7/31.0
X1	6050012830	S.XTA CR-875 TTS14VSB-A3 15.3 MHz	B	82.05/15.35
X2	6070000310	S.DIS JTBM450CX70 <CJE>	B	20.5/24.0
L1	6200014270	S.COI LQM2HPN2R2MJ0L	B	77.1/7.1
L2	6200014290	S.COI CDRH5D18NP-100NCI	B	69.8/7.0
L3	6200014270	S.COI LQM2HPN2R2MJ0L	B	69.8/11.3
L4	6200012170	S.COI MLG1608S R18J-T	B	53.3/17.5
L5	6200014340	S.COI LQW18AN13NG00D	B	49.5/20.3
L7	6200013840	S.COI MLK1005S18NJT	B	52.8/13.2
L8	6200013750	S.COI MLK1005SR10JT	B	49.2/14.8
L9	6200013800	S.COI MLK1005S39NJT	B	42.1/15.8
L10	6200009351	S.COI ELJRE R22GFA	B	41.2/19.9
L11	6200003960	S.COI MLF1608A 1R0K-T	T	55.3/17.4
L12	6200003540	S.COI MLF1608D R22K-T	T	54.8/22.5
L13	6200004480	S.COI MLF1608D R22K-T	T	55.7/26.5
L14	6200011730	S.COI LQW18AN10NG00D	T	42.9/5.9
L17	6200005591	S.COI ELJRE 2N7ZFA	T	36.3/10.6
L19	6200005140	S.COI MLF1608D R33K-T	B	49.0/33.6
L21	6200012800	S.COI 0.40-1.5-5TL 20N <COMO>	T	23.6/9.4
L22	6200012610	S.COI 0.40-0.9-2TL 2.8N <COMO>	T	22.4/6.7
L23	6200011220	S.COI C2012C-R47J-A	B	29.0/29.8
L24	6200012610	S.COI 0.40-0.9-2TL 2.8N <COMO>	T	20.3/6.0
L25	6200004480	S.COI MLF1608D R82K-T	B	21.1/10.3
L28	6200010700	S.COI LQW18AN12NG00D	B	19.4/38.5
L29	6200012610	S.COI 0.40-0.9-2TL 2.8N <COMO>	B	18.2/7.8
L30	6200013840	S.COI MLK1005S18NJT	B	28.6/27.2
L31	6200010700	S.COI LQW18AN12NG00D	B	13.0/40.0
L32	6200013010	S.COI 0.30-0.9-5TL 10.3N <COMO>	B	10.4/9.7
L33	6200009070	S.COI LQW18AN18NG00D (LQW1608A18NG00)	B	9.4/40.2
L34	6200012490	S.COI 0.30-0.9-6TR 13.6N <COMO>	B	7.6/11.9
L35	6200011580	S.COI LQW18AN33NG00D	B	7.6/36.4
L36	6200010850	S.COI LQW18AN22NG00D (LQW1608A22NG00)	B	17.6/10.5
L40	6200011770	S.COI LQW18ANR10G00D	B	3.0/21.2
L41	6200005691	S.COI ELJRE 18NGFA	T	40.1/18.6
L42	6200013980	S.COI MLK1005S1N2ST	T	32.3/13.4
L43	6200009280	S.COI LQW18AN27NG00D (LQW1608A27NG00)	B	4.7/22.8
L44	6200009280	S.COI LQW18AN27NG00D (LQW1608A27NG00)	B	5.9/27.5
L45	6200013780	S.COI MLK1005S56NJT	B	25.3/27.2
R4	7030011910	S.RES ERJ2GEJ 106 X (10M)	T	15.7/27.0
R5	7030012250	S.RES ERJ2RKD 1004X (1M)	T	8.0/27.2
R6	7030012320	S.RES ERJ2RKD 2203X (220K)	T	8.0/28.9
R7	7030003860	S.RES ERJ3GE JPW V	T	24.9/35.4
R8	7030005090	S.RES ERJ2GEJ 104 X (100K)	T	10.9/6.9
R9	7030011910	S.RES ERJ2GEJ 106 X (10M)	T	18.2/26.9
R10	7030005000	S.RES ERJ2GEJ 471 X (470)	T	17.8/35.4
R11	7030007320	S.RES ERJ2GEJ 225 X (2.2M)	T	19.5/21.3
R12	7030011910	S.RES ERJ2GEJ 106 X (10M)	T	17.7/21.3
R13	7030011910	S.RES ERJ2GEJ 106 X (10M)	T	18.6/21.3
R14	7030003860	S.RES ERJ3GE JPW V	B	71.6/28.0
R17	7030010990	S.RES RR0510P-272-D (2.7K)	T	42.1/42.0
R18	7030008340	S.RES RR0510P-182-D (1.8K)	T	41.2/42.9
R19	7030005090	S.RES ERJ2GEJ 104 X (100K)	T	20.4/21.3
R21	7030006290	S.RES RR0510P-333-D (33K)	T	41.2/44.8
R22	7030007280	S.RES ERJ2GEJ 331 X (330)	T	41.2/43.9
R25	7030010040	S.RES ERJ2GEJ-JPW	B	31.9/36.1
R26	7030005120	S.RES ERJ2GEJ 102 X (1K)	T	45.1/44.3
R27	7030007320	S.RES ERJ2GEJ 225 X (2.2M)	T	62.0/13.5
R28	7030003200	S.RES ERJ3GEYJ 100 V (10)	B	47.8/39.4
R30	7030005090	S.RES ERJ2GEJ 104 X (100K)	B	31.9/37.7
R31	7030003200	S.RES ERJ3GEYJ 100 V (10)	B	47.8/40.6
R32	7030008300	S.RES ERJ2GEJ 184 X (180K)	T	62.6/11.5
R33	7030009140	S.RES ERJ2GEJ 272 X (2.7K)	B	43.8/38.8
R34	7030006610	S.RES ERJ2GEJ 394 X (390K)	T	61.7/9.9
R35	7030005720	S.RES ERJ2GEJ 563 X (56K)	T	63.5/9.9
R36	7030005170	S.RES ERJ2GEJ 474 X (470K)	T	63.5/11.5
R37	7030010040	S.RES ERJ2GEJ-JPW	T	62.6/9.9
R38	7030003200	S.RES ERJ3GEYJ 100 V (10)	B	47.8/41.8
R40	7030007860	S.RES ERJ3GEYJ 8R2V (8.2)	B	47.8/43.0
R41	7030007570	S.RES ERJ2GEJ 122 X (1.2K)	T	47.7/12.5
R43	7030007300	S.RES ERJ2GEJ 332 X (3.3K)	B	39.4/38.3
R44	7030011870	S.RES ERJ2BSFR18X (0.18)	T	19.6/15.2
R45	7030011870	S.RES ERJ2BSFR18X (0.18)	T	18.7/15.2
R46	7030011870	S.RES ERJ2BSFR18X (0.18)	T	17.8/15.2
R47	7030005050	S.RES ERJ2GEJ 103 X (10K)	T	55.6/14.0

M.=Mounted side (T: Mounted on the Top side, B: Mounted on the Bottom side) S.=Surface mount

[MAIN UNIT]

REF NO.	PARTS NO.	DESCRIPTION	M.	H/V LOCATION
R48	7030012270	S.RES ERJ2RKD 1203X (120K)	T	13.8/14.2
R49	7030005160	S.RES ERJ2GEJ 105 X (1M)	B	68.8/14.1
R50	7030005290	S.RES ERJ2GEJ 682 X (6.8K)	T	45.6/19.0
R51	7030009190	S.RES RR0510P-332-D (3.3K)	T	76.6/34.9
R52	7030005240	S.RES ERJ2GEJ 473 X (47K)	T	45.6/18.1
R53	7030012260	S.RES ERJ2RKD 4703X (470K)	T	8.0/15.9
R54	7030012250	S.RES ERJ2RKD 1004X (1M)	T	4.2/20.7
R55	7030005120	S.RES ERJ2GEJ 102 X (1K)	T	52.5/4.9
R56	7030011880	S.RES RR0510P-183-D (18K)	T	77.5/36.7
R57	7030012270	S.RES ERJ2RKD 1203X (120K)	B	67.6/20.5
R58	7030012310	S.RES ERJ2RKD 3303X (330K)	T	77.5/35.8
R59	7030005050	S.RES ERJ2GEJ 103 X (10K)	T	4.7/19.5
R60	7030007320	S.RES ERJ2GEJ 225 X (2.2M)	B	47.0/8.8
R61	7030012270	S.RES ERJ2RKD 1203X (120K)	T	12.0/14.5
R62	7030005120	S.RES ERJ2GEJ 102 X (1K)	T	74.6/33.3
R63	7030008260	S.RES RR0510P-393-D (39K)	B	68.8/21.7
R64	7030012310	S.RES ERJ2RKD 3303X (330K)	B	67.9/21.7
R65	7030012250	S.RES ERJ2RKD 1004X (1M)	T	8.9/15.9
R67	7030005030	S.RES ERJ2GEJ 152 X (1.5K)	T	51.6/8.9
R68	7030005050	S.RES ERJ2GEJ 103 X (10K)	T	74.6/32.4
R69	7030012260	S.RES ERJ2RKD 4703X (470K)	T	8.5/17.2
R71	7030007570	S.RES ERJ2GEJ 122 X (1.2K)	T	51.1/10.2
R72	7030008010	S.RES ERJ2GEJ 123 X (12K)	T	60.4/27.7
R73	7030010040	S.RES ERJ2GEJ-JPW	T	60.4/28.6
R74	7030010040	S.RES ERJ2GEJ-JPW	B	45.8/5.0
R75	7030005160	S.RES ERJ2GEJ 105 X (1M)	B	72.1/29.7
R76	7030005240	S.RES ERJ2GEJ 473 X (47K)	T	16.9/13.6
R78	7030007340	S.RES ERJ2GEJ 153 X (15K)	T	65.1/31.7
R79	7030005240	S.RES ERJ2GEJ 473 X (47K)	T	16.9/15.2
R81	7030005600	S.RES ERJ2GEJ 273 X (27K)	T	60.4/31.3
R82	7030005210	S.RES ERJ2GEJ 822 X (8.2K)	B	59.8/16.8
R83	7030005110	S.RES ERJ2GEJ 224 X (220K)	T	65.2/30.1
R84	7030009280	S.RES ERJ2GEJ 391 X	T	69.3/27.8
R88	7030012220	S.RES ERJ2GEJ 185 X (1.8M)	T	62.1/29.7
R89	7030007290	S.RES ERJ2GEJ 222 X (2.2K)	B	58.6/17.4
R90	7030007570	S.RES ERJ2GEJ 122 X (1.2K)	T	52.6/15.9
R91	7030005220	S.RES ERJ2GEJ 223 X (22K)	T	59.5/23.7
R92	7030005110	S.RES ERJ2GEJ 224 X (220K)	T	63.4/30.1
R93	7030008400	S.RES ERJ2GEJ 182 X (1.8K)	B	54.3/19.1
R94	7030005110	S.RES ERJ2GEJ 224 X (220K)	T	66.8/28.7
R96	7030005090	S.RES ERJ2GEJ 104 X (100K)	B	58.6/24.8
R97	7030005530	S.RES ERJ2GEJ 100 X (10)	T	64.3/30.1
R98	7030005080	S.RES ERJ2GEJ 823 X (82K)	T	70.8/27.2
R100	7030007320	S.RES ERJ2GEJ 225 X (2.2M)	B	52.6/23.0
R101	7030008270	S.RES RR0510P-104-D (100K)	B	51.6/21.5
R102	7030005220	S.RES ERJ2GEJ 223 X (22K)	T	59.5/22.8
R103	7030005000	S.RES ERJ2GEJ 471 X (47K)	T	53.2/17.6
R104	7030005080	S.RES ERJ2GEJ 823 X (82K)	T	71.2/28.4
R105	7030005070	S.RES ERJ2GEJ 683 X (68K)	T	68.2/21.2
R106	7030008010	S.RES ERJ2GEJ 123 X (12K)	T	60.7/24.0
R107	7030007350	S.RES ERJ2GEJ 393 X (39K)	T	68.2/22.1
R108	7030005220	S.RES ERJ2GEJ 223 X (22K)	T	13.0/35.3
R109	7030007290	S.RES ERJ2GEJ 222 X (2.2K)	T	12.0/36.9
R110	7030005290	S.RES ERJ2GEJ 682 X (6.8K)	T	51.1/19.5
R111	7030005090	S.RES ERJ2GEJ 104 X (100K)	T	67.4/30.5
R112	7030005090	S.RES ERJ2GEJ 104 X (100K)	T	51.7/15.9
R113	7030005210	S.RES ERJ2GEJ 822 X (8.2K)	T	52.4/18.8
R114	7030005820	S.RES RR0510P-103-D (10K)	B	49.4/22.6
R115	7030007290	S.RES ERJ2GEJ 222 X (2.2K)	T	66.0/20.8
R116	7030007300	S.RES ERJ2GEJ 332 X (3.3K)	T	59.4/20.2
R117	7030006010	S.RES RR0510P-472-D (4.7K)	B	48.2/23.1
R118	7030005060	S.RES ERJ2GEJ 333 X (33K)	B	61.6/30.9
R119	7030004970	S.RES ERJ2GEJ 470 X (47)	B	45.2/23.7
R120	7030008280	S.RES ERJ2GEJ 271 X (27K)	B	47.4/19.0
R121	7030005050	S.RES ERJ2GEJ 103 X (10K)	B	60.4/29.9
R122	7030005240	S.RES ERJ2GEJ 473 X (47K)	B	69.1/30.9
R124	7030005160	S.RES ERJ2GEJ 105 X (1M)	B	58.7/30.0
R125	7030007350	S.RES ERJ2GEJ 393 X (39K)	T	68.7/31.7
R126	7030005110	S.RES ERJ2GEJ 121 X (12K)	B	46.3/17.0
R127	7030005050	S.RES ERJ2GEJ 103 X (10K)	T	67.8/31.7
R128	7030005070	S.RES ERJ2GEJ 683 X (68K)	B	62.8/31.2
R129	7030005070	S.RES ERJ2GEJ 683 X (68K)	B	64.4/31.2
R130	7030005080	S.RES ERJ2GEJ 823 X (82K)	B	45.4/16.1
R132	7030005000	S.RES ERJ2GEJ 471 X (47K)	B	48.3/15.7
R135	7030004980	S.RES ERJ2GEJ 101 X (10K)	B	44.4/17.2
R136	7030005070	S.RES ERJ2GEJ 683 X (68K)	B	66.4/31.9
R137	7030005070	S.RES ERJ2GEJ 683 X (68K)	B	44.9/13.3
R138	7030010040	S.RES ERJ2GEJ-JPW	T	57.1/15.1
R139	7030010040	S.RES ERJ2GEJ-JPW	T	56.7/16.8
R142	7030008410	S.RES ERJ2GEJ 392 X (3.9K)	B	64.3/35.2
R143	7030004980	S.RES ERJ2GEJ 101 X (10K)	B	42.1/12.8
R144	7030005120	S.RES ERJ2GEJ 102 X (1K)	T	57.6/20.6
R145	7030005050	S.RES ERJ2GEJ 103 X (10K)	B	64.7/36.4
R146	7030005060	S.RES ERJ2GEJ 333 X (33K)	B	64.3/34.3
R147	7030007280	S.RES ERJ2GEJ 331 X (33K)	B	70.1/35.8
R149	7030005110	S.RES ERJ2GEJ 224 X (220K)	B	66.0/36.9
R150	7030005090	S.RES ERJ2GEJ 104 X (100K)	B	70.2/34.9
R151	7030005060	S.RES ERJ2GEJ 333 X (33K)	B	42.2/17.9
R152	7030005090	S.RES ERJ2GEJ 104 X (100K)	B	65.5/38.4
R153	7030005050	S.RES ERJ2GEJ 103 X (10K)	T	64.2/14.1
R154	7030005050	S.RES ERJ2GEJ 103 X (10K)	T	64.4/16.8
R155	7030005050	S.RES ERJ2GEJ 103 X (10K)	T	64.4/18.4
R156	7030004970	S.RES ERJ2GEJ 470 X (47)	B	43.4/18.3
R157	7030009140	S.RES ERJ2GEJ 272 X (2.7K)	T	40.0/25.3
R158	7030009290	S.RES ERJ2GEJ 562 X (5.6K)	T	38.4/22.7
R159	7030005030	S.RES ERJ2GEJ 152 X (1.5K)	B	40.1/21.4
R160	7030008010	S.RES ERJ2GEJ 123 X (12K)	T	39.9/32.5
R161	7030005050	S.RES ERJ2GEJ 103 X (10K)	T	46.3/40.8
R162	7030005050	S.RES ERJ2GEJ 103 X (10K)	T	41.0/30.5
R163	7030005120	S.RES ERJ2GEJ 102 X (1K)	T	27.1/23.3
R164	7030005240	S.RES ERJ2GEJ 473 X (47K)	T	26.3/21.4
R165	7030007060	S.RES ERJ2GEJ 684X (680K)	T	53.9/20.1
R166	7030004980	S.RES ERJ2GEJ 101 X (10K)	T	54.0/23.9
R167	7030005050	S.RES ERJ2GEJ 103 X (10K)	T	49.9/40.3
R168	7030005050	S.RES ERJ2GEJ 103 X (10K)	T	53.6/36.1

Eqv.= This component is equivalent to the REF No. component listed above, and may be substituted on parts orders and repairs.

[MAIN UNIT]

REF NO.	PARTS NO.	DESCRIPTION	M.	H/V LOCATION
R169	7030005220	S.RES ERJ2GEJ 223 X (22K)	B	39.9/7.5
R170	7030008010	S.RES ERJ2GEJ 123 X (12K)	B	50.9/42.2
R171	7030005060	S.RES ERJ2GEJ 333 X (33K)	T	41.2/7.0
R172	7030005100	S.RES ERJ2GEJ 154 X (150K)	B	56.6/36.7
R173	7030005120	S.RES ERJ2GEJ 102 X (1K)	B	59.1/36.7
R174	7030005120	S.RES ERJ2GEJ 102 X (1K)	T	42.6/16.0
R176	7030010130	S.RES ERJ2GEJ 6R8 X (6.8)	T	44.4/12.8
R177	7030005230	S.RES ERJ2GEJ 334 X (330K)	B	41.2/5.2
R178	7030005160	S.RES ERJ2GEJ 105 X (1M)	B	39.5/4.5
R179	7030005100	S.RES ERJ2GEJ 154 X (150K)	B	60.0/36.7
R180	7030005120	S.RES ERJ2GEJ 102 X (1K)	T	40.5/15.3
R181	7030005050	S.RES ERJ2GEJ 103 X (10K)	T	39.3/14.8
R182	7030005810	S.RES RR0510P-152-D (1.5K)	B	51.4/37.6
R183	7030005120	S.RES ERJ2GEJ 102 X (1K)	T	42.6/12.8
R184	7030005810	S.RES RR0510P-152-D (1.5K)	T	39.6/16.9
R185	7030009140	S.RES ERJ2GEJ 272 X (2.7K)	T	40.2/9.8
R186	7030005210	S.RES ERJ2GEJ 822 X (8.2K)	T	43.2/11.4
R187	7030004980	S.RES ERJ2GEJ 101 X (10K)	T	37.5/17.4
R188	7030010010	S.RES ERJ2PRKF 334 X (330K)	B	36.4/9.3
R189	7030005220	S.RES ERJ2GEJ 223 X (22K)	B	35.5/9.3
R191	7030005160	S.RES ERJ2GEJ 105 X (1M)	B	36.0/10.5
R192	7030009280	S.RES ERJ2GEJ 391 X	B	37.5/4.5
R193	7030005090	S.RES ERJ2GEJ 104 X (100K)	B	52.8/28.2
R194	7030005060	S.RES ERJ2GEJ 333 X (33K)	B	33.7/10.1
R195	7030008400	S.RES ERJ2GEJ 182 X (1.8K)	B	56.1/28.2
R196	7030009190	S.RES RR0510P-332-D (3.3K)	T	56.8/35.2
R197	7030007250	S.RES ERJ2GEJ 220 X (22)	B	48.2/36.8
R198	7030008400	S.RES ERJ2GEJ 182 X (1.8K)	T	57.9/26.9
R199	7030005240	S.RES ERJ2GEJ 473 X (47K)	T	57.0/39.9
R200	7030005590	S.RES ERJ2GEJ 680 X (68)	T	34.1/11.6
R201	7030004970	S.RES ERJ2GEJ 470 X (47)	T	36.9/5.2
R202	7030005240	S.RES ERJ2GEJ 473 X (47K)	T	36.1/3.2
R203	7030008310	S.RES ERJ2GEJ 564 X (560K)	B	34.9/20.1
R204	7030005240	S.RES ERJ2GEJ 473 X (47K)	T	55.2/36.1
R205	7030009190	S.RES RR0510P-332-D (3.3K)	T	32.7/11.6
R206	7030007340	S.RES ERJ2GEJ 153 X (15K)	B	31.0/20.9
R207	7030007340	S.RES ERJ2GEJ 153 X (15K)	B	27.9/21.4
R209	7030005590	S.RES ERJ2GEJ 680 X (68)	B	49.3/28.1
R210	7030010040	S.RES ERJ2GEJ-JPW	T	33.2/11.6
R211	7030009160	S.RES ERJ2GEJ 471 X (180)	B	46.8/34.9
R212	7030005000	S.RES ERJ2GEJ 181 X (470)	B	48.7/35.6
R213	7030004980	S.RES ERJ2GEJ 101 X (10K)	T	32.7/15.5
R214	7030005720	S.RES ERJ2GEJ 563 X (56K)	B	46.4/33.7
R215	7030004990	S.RES ERJ2GEJ 221 X (220)	T	34.4/22.3
R216	7030005050	S.RES ERJ2GEJ 103 X (10K)	B	33.3/24.0
R217	7030004970	S.RES ERJ2GEJ 470 X (47)	T	31.4/15.1
R218	7030007340	S.RES ERJ2GEJ 153 X (15K)	T	30.7/17.2
R220	7510001770	S.THE NTCG10 4LH 47K	B	22.3/13.2
R221	7030005820	S.RES RR0510P-103-D (10K)	B	21.6/15.1
R222	7030004980	S.RES ERJ2GEJ 101 X (10K)	B	34.9/29.9
R223	7030007290	S.RES ERJ2GEJ 222 X (2.2K)	B	22.1/16.4
R224	7030007280	S.RES ERJ2GEJ 331 X (330)	B	21.4/13.2
R225	7030005010	S.RES ERJ2GEJ 681 X (680)	B	30.9/31.2
R226	7030007250	S.RES ERJ2GEJ 220 X (22)	B	27.4/28.4
R227	7030005080	S.RES ERJ2GEJ 823 X (82K)	B	26.5/28.4
R228	7030005090	S.RES ERJ2GEJ 104 X (100K)	B	24.7/32.1
R229	7030005090	S.RES ERJ2GEJ 104 X (100K)	B	24.7/32.1
R230	7030005120	S.RES ERJ2GEJ 102 X (1K)	B	25.3/25.4
R232	7030005060	S.RES ERJ2GEJ 333 X (33K)	T	16.4/9.9
R233	7030010040	S.RES ERJ2GEJ-JPW	B	26.9/27.2
R235	7030005090	S.RES ERJ2GEJ 104 X (100K)	B	17.2/41.7
R236	7030005240	S.RES ERJ2GEJ 473 X (47K)	T	15.5/9.0
R237	7030008010	S.RES ERJ2GEJ 123 X (12K)	T	14.8/11.9
R238	7030005090	S.RES ERJ2GEJ 104 X (100K)	B	15.5/42.6
R239	7030010040	S.RES ERJ2GEJ-JPW	B	30.2/27.2
R241	7030005090	S.RES ERJ2GEJ 104 X (100K)	B	11.5/39.2
R242	7030005080	S.RES ERJ2GEJ 823 X (82K)	T	8.1/10.3
R243	7030005040	S.RES ERJ2GEJ 472 X (4.7K)	B	7.1/35.4
R244	7030007250	S.RES ERJ2GEJ 220 X (22)	B	8.7/37.5
R246	7030010040	S.RES ERJ2GEJ-JPW	B	6.5/34.1
R248	7030008290	S.RES ERJ2GEJ 183 X (18K)	B	4.1/31.3
R249	7030007280	S.RES ERJ2GEJ 331 X (330)	B	7.0/17.2
R251	7030005090	S.RES ERJ2GEJ 104 X (100K)	B	2.5/24.7
R252	7030005090	S.RES ERJ2GEJ 104 X (100K)	B	5.1/23.9
R253	7030005600	S.RES ERJ2GEJ 273 X (27K)	T	41.1/21.5
R254	7030004970	S.RES ERJ2GEJ 470 X (47)	T	41.7/17.6
R255				

[MAIN UNIT]

REF NO.	PARTS NO.	DESCRIPTION	M.	H/V LOCATION
C10	4030017460	S.CER C1005 JB 1H 102K-T	B	52.8/41.1
C11	4030017350	S.CER C1005 CH 1H 020B-T	T	13.9/22.7
C12	4030017460	S.CER C1005 JB 1H 102K-T	T	15.5/35.4
C13	4030017030	S.CER C1005 JB 1A 273K-T	T	17.8/25.7
C14	4550007090	S.TAN TEESVA 1A 226M8R	T	16.6/36.9
Eqv.	4550008160	S.TAN F931A226MAA		
C15	4030017460	S.CER C1005 JB 1H 102K-T	T	20.9/19.1
C17	4030017420	S.CER C1005 CH 1H 470J-T	T	26.8/33.2
C18	4030017460	S.CER C1005 JB 1H 102K-T	B	14.6/43.8
C20	4030017460	S.CER C1005 JB 1H 102K-T	B	76.4/27.6
C21	4520000020	S.NIO NOJC227M006RWJV	T	29.1/35.0
C22	4030017460	S.CER C1005 JB 1H 102K-T	B	50.1/39.1
C23	4510010250	S.ELE 16 CE 22 LD	T	35.8/45.6
C24	4030017460	S.CER C1005 JB 1H 102K-T	B	34.6/44.5
C25	4520000020	S.NIO NOJC227M006RWJV	T	33.0/35.0
C27	4030018860	S.CER C1005 JB 0J 105K-T	T	60.8/11.5
C28	4030018860	S.CER C1005 JB 0J 105K-T	T	61.7/11.5
C29	4030017460	S.CER C1005 JB 1H 102K-T	T	46.0/44.3
C30	4030017420	S.CER C1005 CH 1H 470J-T	T	60.8/9.9
C32	4030019560	S.CER GRM21BB31C106KE15L	T	46.0/11.7
C33	4030017460	S.CER C1005 JB 1H 102K-T	T	47.7/11.6
C34	4030016930	S.CER C1005 JB 1A 104K-T	B	40.6/35.8
C35	4030017460	S.CER C1005 JB 1H 102K-T	B	47.2/38.0
C36	4030016790	S.CER C1005 JB 1E 103K-T	T	61.8/6.6
C38	4030018860	S.CER C1005 JB 0J 105K-T	B	39.7/35.8
C39	4030018860	S.CER C1005 JB 0J 105K-T	T	62.7/6.6
C40	4550006250	S.TAN TEESVA 1A 106M8R	T	47.8/17.8
Eqv.	4550007520	S.TAN F931A106MAABMA		
C41	4030018960	S.CER C3216 JB 1C 106MT-N	B	76.4/11.5
C42	4030018960	S.CER C3216 JB 1C 106MT-N	B	76.4/13.6
C43	4030019120	S.CER GRM188B31E105KA75D	B	62.5/9.4
C45	4030017620	S.CER C1005 CH 1H 100C-T	T	55.6/13.1
C46	4030016930	S.CER C1005 JB 1A 104K-T	B	36.6/34.9
C48	4030018900	S.CER C1005 JB 0J 474K-T	B	41.4/37.7
C49	4030017460	S.CER C1005 JB 1H 102K-T	T	54.1/4.9
C50	4030016970	S.CER C1005 JB 1E 223K-T	B	37.5/35.0
C52	4030018860	S.CER C1005 JB 0J 105K-T	B	45.7/7.4
C54	4030017460	S.CER C1005 JB 1H 102K-T	T	45.6/19.9
C55	4030016930	S.CER C1005 JB 1A 104K-T	B	45.7/6.5
C56	4030019120	S.CER GRM188B31E105KA75D	B	71.5/9.6
C57	4030019120	S.CER GRM188B31E105KA75D	B	58.7/6.0
C59	4030017730	S.CER C1005 JB 1H 471K-T	B	47.0/7.0
C60	4550007970	S.TAN TMCMC1A107MTRF	T	36.8/36.0
C61	4030018960	S.CER C3216 JB 1C 106MT-N	B	69.2/16.2
C62	4030017430	S.CER C1005 CH 1H 101J-T	T	5.1/20.7
C63	4030017460	S.CER C1005 JB 1H 102K-T	B	77.3/36.1
C64	4030018960	S.CER C3216 JB 1C 106MT-N	B	69.2/18.3
C65	4030017460	S.CER C1005 JB 1H 102K-T	T	4.7/21.9
C66	4030017640	S.CER C1005 CH 1H 150J-T	B	68.8/20.1
C67	4030017460	S.CER C1005 JB 1H 102K-T	B	46.1/8.8
C68	4030017460	S.CER C1005 JB 1H 102K-T	T	74.6/34.2
C69	4030019460	S.CER C1608 JB 0J 106M-T	B	73.7/22.6
C70	4030017460	S.CER C1005 JB 1H 102K-T	B	47.0/4.9
C71	4030017460	S.CER C1005 JB 1H 102K-T	T	8.5/18.1
C72	4550006250	S.TAN TEESVA 1A 106M8R	T	76.3/30.8
Eqv.	4550007520	S.TAN F931A106MAABMA		
C73	4030017460	S.CER C1005 JB 1H 102K-T	T	49.0/6.5
C74	4550000540	S.TAN TEESVA 1V 154M8R	T	51.3/11.7
Eqv.	4550008360	S.TAN 267M3502 154MR		
C75	4030017460	S.CER C1005 JB 1H 102K-T	B	74.7/30.4
C76	4030017460	S.CER C1005 JB 1H 102K-T	B	72.1/30.6
C77	4030017040	S.CER C1005 JB 1A 333K-T	T	66.0/31.7
C78	4030017460	S.CER C1005 JB 1H 102K-T	T	5.1/23.9
C80	4030017780	S.CER C1005 JB 1H 472K-T	T	66.1/30.1
C81	4030017780	S.CER C1005 JB 1H 472K-T	B	60.4/30.4
C82	4030017460	S.CER C1005 JB 1H 102K-T	T	47.4/5.7
C83	4030017920	S.CER C1005 JB 1A 683K-T	T	70.2/26.0
C84	4030017460	S.CER C1005 JB 1H 102K-T	T	12.0/15.4
C85	4030017420	S.CER C1005 CH 1H 470J-T	B	58.6/15.9
C86	4030017460	S.CER C1005 JB 1H 102K-T	T	66.9/31.7
C88	4030017910	S.CER C1005 JB 1H 152K-T	T	61.6/30.9
C89	4030018920	S.CER C1005 JB 1H 392K-T	T	62.5/30.9
C90	4030017420	S.CER C1005 CH 1H 470J-T	B	62.2/18.5
C91	4030016930	S.CER C1005 JB 1A 104K-T	T	53.5/15.9
C92	4030017460	S.CER C1005 JB 1H 102K-T	T	50.5/15.5
C93	4030017460	S.CER C1005 JB 1H 102K-T	T	54.1/5.8
C94	4030017460	S.CER C1005 JB 1H 102K-T	T	24.7/26.2
C95	4030017460	S.CER C1005 JB 1H 102K-T	T	69.3/26.0
C96	4550002980	S.TAN TEESVA 1C 225M8R	T	51.3/13.9
Eqv.	4550007390	S.TAN F931C225MAABMA		
C98	4030016790	S.CER C1005 JB 1E 103K-T	B	58.6/18.3
C99	4550006250	S.TAN TEESVA 1A 106M8R	T	67.8/25.3
Eqv.	4550007520	S.TAN F931A106MAABMA		
C100	4030017710	S.CER C1005 CH 1H 181J-T	T	67.7/28.7
C101	4030016790	S.CER C1005 JB 1E 103K-T	B	58.3/20.2
C102	4550000550	S.TAN TEESVA 1V 224M8R	B	54.2/22.1
Eqv.	4550008150	S.TAN F921V224MAA		
C103	4030017520	S.CER C1005 CH 1H 0R3B-T	B	51.6/23.0
C104	4030016790	S.CER C1005 JB 1E 103K-T	T	57.9/22.2
C105	4550005980	S.TAN TEESVA 1A 475M8R	T	7.7/34.3
Eqv.	4550007270	S.TAN F931A475MAABMA		
C106	4030018110	S.CER C1005 JB 1H 272K-T	T	69.3/24.2
C107	4030016790	S.CER C1005 JB 1E 103K-T	T	11.1/36.9
C108	4030017520	S.CER C1005 CH 1H 0R3B-T	B	50.6/23.0
C110	4030017460	S.CER C1005 JB 1H 102K-T	T	51.1/20.4
C111	4030017460	S.CER C1005 JB 1H 102K-T	B	58.6/25.7
C112	4030017790	S.CER C1005 JB 1H 682K-T	T	60.7/22.4
C113	4030018860	S.CER C1005 JB 0J 105K-T	T	59.5/21.9
C114	4030018140	S.CER C1005 JB 1H 391K-T	T	66.9/21.6
C115	4030019560	S.CER GRM21BB31C106KE15L	T	70.1/30.1
C116	4030017460	S.CER C1005 JB 1H 102K-T	T	57.9/25.7
C117	4030017460	S.CER C1005 JB 1H 102K-T	T	6.7/38.4
C118	4030017460	S.CER C1005 JB 1H 102K-T	B	49.4/23.5
C119	4030006990	S.CER C1608 CH 1H 080D-T	B	49.5/21.6
C120	4550007090	S.TAN TEESVA 1A 226M8R	T	7.7/36.9

Eqv.= This component is equivalent to the REF No. component listed above, and may be substituted on parts orders and repairs.

[MAIN UNIT]

REF NO.	PARTS NO.	DESCRIPTION	M.	H/V LOCATION
Eqv.	4550008160	S.TAN F931A226MAA		
C122	4030018820	S.CER C1005 JB 1H 561K-T	B	60.4/31.7
C123	4030017910	S.CER C1005 JB 1H 152K-T	T	59.5/24.6
C124	4030007020	S.CER C1608 CH 1H 120J-T	B	46.9/21.6
C125	4030007010	S.CER C1608 CH 1H 100D-T	B	46.9/20.3
C126	4030017460	S.CER C1005 JB 1H 102K-T	B	45.2/22.1
C127	4030017460	S.CER C1005 JB 1H 102K-T	T	63.9/32.2
C128	4030017040	S.CER C1005 JB 1A 333K-T	T	64.6/20.8
C129	4030016930	S.CER C1005 JB 1A 104K-T	B	66.7/27.9
C130	4030018080	S.CER C1005 JB 1H 182K-T	B	60.4/30.8
C131	4030017460	S.CER C1005 JB 1H 102K-T	B	48.3/16.6
C132	4030017530	S.CER C1005 CH 1H 0R5B-T	B	46.2/18.6
C133	4550006250	S.TAN TEESVA 1A 106M8R	B	52.6/15.1
Eqv.	4550007520	S.TAN F931A106MAABMA		
C135	4030018860	S.CER C1005 JB 0J 105K-T	B	57.5/30.3
C136	4030019460	S.CER C1608 JB 0J 106M-T	T	65.3/12.6
C137	4030017360	S.CER C1005 CH 1H 030B-T	B	51.9/13.2
C138	4030017360	S.CER C1005 CH 1H 030B-T	B	53.7/13.2
C139	4030017420	S.CER C1005 CH 1H 470J-T	B	50.7/13.6
C140	4030017460	S.CER C1005 JB 1H 102K-T	B	44.5/16.0
C141	4030016930	S.CER C1005 JB 1A 104K-T	B	57.5/29.4
C142	4030017790	S.CER C1005 JB 1H 682K-T	B	64.4/30.3
C143	4030016930	S.CER C1005 JB 1A 104K-T	T	68.4/11.3
C144	4030017570	S.CER C1005 CH 1H 040B-T	B	49.5/13.9
C145	4030016790	S.CER C1005 JB 1E 103K-T	T	57.6/16.3
C147	4030016970	S.CER C1005 JB 1E 223K-T	B	65.2/32.4
C148	4030017460	S.CER C1005 JB 1H 102K-T	B	44.5/19.2
C149	4030017360	S.CER C1005 CH 1H 030B-T	B	42.1/17.6
C150	4030017430	S.CER C1005 CH 1H 101J-T	B	43.7/12.8
C151	4030016790	S.CER C1005 JB 1E 103K-T	B	47.6/14.8
C152	4030017760	S.CER C1005 JB 1H 222K-T	B	68.0/31.9
C153	4030017420	S.CER C1005 CH 1H 470J-T	B	43.6/16.0
C154	4030017400	S.CER C1005 CH 1H 220J-T	B	40.4/13.7
C155	4030019120	S.CER GRM188B31E105KA75D	T	71.3/20.5
C157	4030016790	S.CER C1005 JB 1E 103K-T	B	63.0/34.7
C158	4030017460	S.CER C1005 JB 1H 102K-T	B	40.9/15.0
C159	4030017040	S.CER C1005 JB 1A 333K-T	B	64.4/39.6
C160	4030019460	S.CER C1608 JB 0J 106M-T	B	65.8/35.2
C161	4030017460	S.CER C1005 JB 1H 102K-T	B	42.2/18.8
C162	4030017460	S.CER C1005 JB 1H 102K-T	B	43.3/19.7
C163	4030019120	S.CER GRM188B31E105KA75D	T	70.7/15.8
C165	4030017670	S.CER C1005 CH 1H 390J-T	B	41.0/21.4
C166	4030017460	S.CER C1005 JB 1H 102K-T	T	37.2/22.7
C167	4030017340	S.CER C1005 CH 1H 010B-T	B	41.9/21.4
C168	4030017460	S.CER C1005 JB 1H 102K-T	T	39.1/25.3
C169	4030017460	S.CER C1005 JB 1H 102K-T	T	55.6/39.4
C170	4030016930	S.CER C1005 JB 1A 104K-T	T	44.0/39.8
C171	4030016930	S.CER C1005 JB 1A 104K-T	T	39.9/29.2
C172	4030017620	S.CER C1005 CH 1H 100C-T	T	55.3/15.2
C173	4030016790	S.CER C1005 JB 1E 103K-T	T	28.0/23.3
C174	4030016930	S.CER C1005 JB 1A 104K-T	T	49.0/40.3
C175	4030016930	S.CER C1005 JB 1A 104K-T	T	53.6/35.2
C176	4550007090	S.TAN TEESVA 1A 226M8R	T	29.5/24.8
Eqv.	4550008160	S.TAN F931A226MAA		
C177	4030016790	S.CER C1005 JB 1E 103K-T	B	41.2/7.9
C178	4030016790	S.CER C1005 JB 1E 103K-T	T	53.9/21.0
C179	4030017500	S.CER C1005 CH 1H 560J-T	T	55.8/23.9
C180	4030017460	S.CER C1005 JB 1H 102K-T	T	47.5/41.3
C181	4030018860	S.CER C1005 JB 0J 105K-T	T	55.2/37.8
C182	4030017570	S.CER C1005 CH 1H 040B-T	T	54.9/23.9
C183	4030017660	S.CER C1005 CH 1H 330J-T	T	40.5/16.9
C185	4030017590	S.CER C1005 CH 1H 070C-T	T	55.4/25.2
C186	4030017730	S.CER C1005 JB 1H 471K-T	B	57.9/37.1
C187	4030016930	S.CER C1005 JB 1A 104K-T	T	38.9/31.4
C189	4030017460	S.CER C1005 JB 1H 102K-T	B	34.7/4.9
C190	4030016930	S.CER C1005 JB 1A 104K-T	T	52.5/40.1
C192	4030017730	S.CER C1005 JB 1H 471K-T	B	57.9/36.2
C193	4030017460	S.CER C1005 JB 1H 102K-T	B	60.0/35.0
C194	4030016950	S.CER C1005 JB 1A 473K-T	B	41.2/6.1
C195	4030017360	S.CER C1005 CH 1H 030B-T	T	54.0/25.7
C196	4030016930	S.CER C1005 JB 1A 104K-T	B	55.1/37.9
C197	4030016930	S.CER C1005 JB 1A 104K-T	T	44.0/10.2
C198	4030016790	S.CER C1005 JB 1E 103K-T	B	35.6/6.6
C199	4030018860	S.CER C1005 JB 0J 105K-T	B	50.0/36.8
C200	4030017460			

[MAIN UNIT]

REF NO.	PARTS NO.	DESCRIPTION	M.	H/V LOCATION
C237	4030017460	S.CER C1005 JB 1H 102K-T	T	32.5/18.3
C238	4030016790	S.CER C1005 JB 1E 103K-T	B	47.3/33.7
C240	4030016790	S.CER C1005 JB 1E 103K-T	B	49.3/29.7
C242	4550007650	S.TAN F931V105MAABMA	T	23.9/17.7
C243	4030017460	S.CER C1005 JB 1H 102K-T	B	46.1/35.8
C244	4030017650	S.CER C1005 CH 1H 270J-T	B	48.7/34.7
C246	4030017460	S.CER C1005 JB 1H 102K-T	T	37.2/20.0
C250	4030017640	S.CER C1005 CH 1H 150J-T	T	31.4/13.4
C251	4030017460	S.CER C1005 JB 1H 102K-T	T	24.0/13.0
C252	4030017460	S.CER C1005 JB 1H 102K-T	T	31.6/16.7
C253	4030016790	S.CER C1005 JB 1E 103K-T	B	46.4/30.4
C256	4030017600	S.CER C1005 CH 1H 080C-T	B	44.8/30.8
C257	4030017460	S.CER C1005 JB 1H 102K-T	B	20.9/12.0
C259	4030017640	S.CER C1005 CH 1H 150J-T	B	42.3/27.8
C260	4030007080	S.CER C1608 CH 1H 390J-T	T	23.9/6.0
C261	4030017460	S.CER C1005 JB 1H 102K-T	B	22.1/18.0
C262	4030017460	S.CER C1005 JB 1H 102K-T	B	30.9/32.1
C263	4030016790	S.CER C1005 JB 1E 103K-T	B	30.9/29.4
C264	4030017580	S.CER C1005 CH 1H 060C-T	B	34.9/31.5
C265	4030007020	S.CER C1608 CH 1H 120J-T	T	17.9/7.3
C266	4030016790	S.CER C1005 JB 1E 103K-T	B	30.9/28.5
C267	4030007010	S.CER C1608 CH 1H 100D-T	T	17.9/6.1
C269	4030017460	S.CER C1005 JB 1H 102K-T	B	20.5/13.2
C270	4030009520	S.CER C1608 CH 1H 020B-T	T	17.9/4.8
C271	4030017400	S.CER C1005 CH 1H 220J-T	B	30.9/30.3
C272	4030017810	S.CER C1608 CH 1H 102J-T	B	20.7/5.8
C273	4030017460	S.CER C1005 JB 1H 102K-T	B	25.6/28.4
C274	4030017460	S.CER C1005 JB 1H 102K-T	T	26.7/30.6
C278	4030017520	S.CER C1005 CH 1H 0R3B-T	B	19.7/9.7
C279	4030017630	S.CER C1005 CH 1H 120J-T	B	21.2/36.2
C280	4030017590	S.CER C1005 CH 1H 070C-T	B	27.4/25.8
C281	4030009520	S.CER C1608 CH 1H 020B-T	B	18.8/5.5
C282	4030017460	S.CER C1005 JB 1H 102K-T	T	16.8/11.1
C285	4030009530	S.CER C1608 CH 1H 030B-T	B	17.6/5.5
C286	4030017340	S.CER C1005 CH 1H 010B-T	B	17.2/40.8
C287	4030017460	S.CER C1005 JB 1H 102K-T	T	12.8/8.1
C289	4030017590	S.CER C1005 CH 1H 070C-T	B	28.6/25.4
C290	4030018070	S.CER C1005 CH 1H 300J-T	B	15.9/39.6
C291	4030017460	S.CER C1005 JB 1H 102K-T	B	19.6/40.9
C292	4030017340	S.CER C1005 CH 1H 010B-T	B	15.5/41.7
C293	4030017340	S.CER C1005 CH 1H 010B-T	B	15.5/40.8
C294	4030017460	S.CER C1005 JB 1H 102K-T	B	31.4/26.7
C296	4030017460	S.CER C1005 JB 1H 102K-T	B	19.6/41.8
C297	4030017350	S.CER C1005 CH 1H 020B-T	B	14.1/39.6
C298	4030017810	S.CER C1608 CH 1H 102J-T	B	13.9/9.4
C299	4030017650	S.CER C1005 CH 1H 270J-T	B	15.0/39.6
C300	4030017340	S.CER C1005 CH 1H 010B-T	B	12.8/42.6
C301	4030017340	S.CER C1005 CH 1H 010B-T	B	12.8/41.7
C302	4030009350	S.CER C1608 CH 1H 3R5B-T	B	11.5/7.6
C303	4030009520	S.CER C1608 CH 1H 020B-T	B	12.0/9.6
C304	4030017340	S.CER C1005 CH 1H 010B-T	B	10.4/41.6
C305	4030017650	S.CER C1005 CH 1H 270J-T	B	10.4/40.0
C306	4030006990	S.CER C1608 CH 1H 080D-T	B	7.2/13.6
C307	4030009500	S.CER C1608 CH 1H 0R5B-T	B	7.9/10.3
C309	4030017460	S.CER C1005 JB 1H 102K-T	B	10.4/38.4
C310	4030017510	S.CER C1005 CH 1H 680J-T	B	7.4/38.8
C311	4030017460	S.CER C1005 JB 1H 102K-T	B	7.4/34.1
C312	4030009910	S.CER C1608 CH 1H 040B-T	B	4.5/11.9
C313	4030017350	S.CER C1005 CH 1H 020B-T	B	19.7/10.6
C314	4030017340	S.CER C1005 CH 1H 010B-T	B	7.1/37.5
C315	4030017340	S.CER C1005 CH 1H 010B-T	B	15.9/10.5
C316	4030017460	S.CER C1005 JB 1H 102K-T	B	4.6/32.5
C319	4030017460	S.CER C1005 JB 1H 102K-T	B	6.1/17.2
C320	4030017430	S.CER C1005 CH 1H 101J-T	B	3.8/24.2
C324	4030017360	S.CER C1005 CH 1H 030B-T	B	4.7/21.5
C325	4030017380	S.CER C1005 CH 1H 050B-T	B	4.2/20.2
C326	4030017430	S.CER C1005 CH 1H 101J-T	B	5.6/19.9
C327	4030017380	S.CER C1005 CH 1H 050B-T	T	40.6/19.7
C328	4030017460	S.CER C1005 JB 1H 102K-T	T	41.1/20.6
C329	4030017380	S.CER C1005 CH 1H 050B-T	T	39.3/22.7
C330	4030017460	S.CER C1005 JB 1H 102K-T	T	42.2/18.5
C331	4030017430	S.CER C1005 CH 1H 101J-T	T	38.6/30.2
C333	4030007080	S.CER C1608 CH 1H 390J-T	T	25.1/6.0
C334	4030017460	S.CER C1005 JB 1H 102K-T	B	6.3/24.3
C335	4030017460	S.CER C1005 JB 1H 102K-T	B	2.1/22.6
C336	4030017460	S.CER C1005 JB 1H 102K-T	T	45.7/14.9
C337	4030016790	S.CER C1005 JB 1E 103K-T	T	33.2/28.5
C338	4030016790	S.CER C1005 JB 1E 103K-T	T	34.9/30.5
C339	4030017460	S.CER C1005 JB 1H 102K-T	B	7.2/24.3
C340	4030016950	S.CER C1005 JB 1A 473K-T	T	27.4/28.3
C341	4030016930	S.CER C1005 JB 1A 104K-T	T	31.4/28.5
C342	4030017460	S.CER C1005 JB 1H 102K-T	B	60.9/22.4
C343	4030017460	S.CER C1005 JB 1H 102K-T	B	64.9/29.0
C344	4030017460	S.CER C1005 JB 1H 102K-T	B	64.0/29.0
C345	4030017460	S.CER C1005 JB 1H 102K-T	B	62.0/22.4
C346	4030017460	S.CER C1005 JB 1H 102K-T	T	20.9/18.2
C347	4030017460	S.CER C1005 JB 1H 102K-T	T	22.1/25.8
C348	4030017460	S.CER C1005 JB 1H 102K-T	T	17.0/27.7
C349	4030017460	S.CER C1005 JB 1H 102K-T	B	8.7/38.4
C350	4030017530	S.CER C1005 CH 1H 0R5B-T	B	13.6/10.5
C351	4030017390	S.CER C1005 CH 1H 180J-T	T	32.3/11.6
C352	4030016930	S.CER C1005 JB 1A 104K-T	T	18.7/25.7
C353	4030017340	S.CER C1005 CH 1H 010B-T	B	5.6/21.5
C354	4030016790	S.CER C1005 JB 1E 103K-T	T	57.3/19.4
C355	4030016940	S.CER C1005 JB 1A 393K-T	B	59.0/28.8
C356	4030017420	S.CER C1005 CH 1H 470J-T	T	77.4/25.5
C357	4030017420	S.CER C1005 CH 1H 470J-T	B	38.4/35.0
C358	4030017420	S.CER C1005 CH 1H 470J-T	T	24.1/34.0
C359	4030018860	S.CER C1005 JB 0J 105K-T	B	67.6/27.9
C360	4030018860	S.CER C1005 JB 0J 105K-T	T	73.5/13.1
C361	4030017390	S.CER C1005 CH 1H 180J-T	T	38.1/5.7
C362	4030018860	S.CER C1005 JB 0J 105K-T	T	31.6/22.5
C363	4030020450	S.CER C1005 JB 0J 475M-T	T	59.5/26.8

Eqv.= This component is equivalent to the REF No. component listed above, and may be substituted on parts orders and repairs.

[MAIN UNIT]

REF NO.	PARTS NO.	DESCRIPTION	M.	H/V LOCATION
J2	6450000870	CON HEC2711-01-020		
J3	6510028130	S.CON AXK5S50047YG	T	66.5/37.2
J4	6510025880	CON TC38-108-01 <CFE>		
J5	6450000131	CON HSJ1102-018540		
S1	2260003320	S.SWI SKRTLAE010	T	31.5/2.0
S2	2260001900	SWI SW-149 (SKHLLD)		
EP2	6910019100	S.BEA MPZ1608S101AT	T	10.6/32.0
EP3	6910014730	S.BEA MPZ2012S331A-T	B	60.7/44.2
EP4	6910019100	S.BEA MPZ1608S101AT	T	13.1/20.5
EP5	6910019100	S.BEA MPZ1608S101AT	B	55.8/40.0
EP6	6910019100	S.BEA MPZ1608S101AT	B	53.1/40.0
EP7	6910018460	S.BEA MMZ1005Y102C-T	T	19.6/36.7
EP8	6910018460	S.BEA MMZ1005Y102C-T	B	12.1/43.8
EP9	6910018460	S.BEA MMZ1005Y102C-T	B	14.6/44.7
EP10	6910014680	S.BEA MMZ1608Y 121BT	T	24.1/32.7
EP11	6910018460	S.BEA MMZ1005Y102C-T	B	24.2/42.2
EP12	6910014680	S.BEA MMZ1608Y 121BT	B	22.3/43.6
EP13	6910018460	S.BEA MMZ1005Y102C-T	B	34.7/6.6
EP14	6910021230	S.BEA MMZ2012Y102BT	T	35.5/13.3
EP15	6910018460	S.BEA MMZ1005Y102C-T	T	37.2/43.8
EP16	6910019100	S.BEA MPZ1608S101AT	T	21.2/13.4
EP17	6910018460	S.BEA MMZ1005Y102C-T	B	22.1/19.6
EP18	6910019100	S.BEA MPZ1608S101AT	T	10.9/19.8
EP19	6910019100	S.BEA MPZ1608S101AT	T	66.2/7.7

M.=Mounted side (T: Mounted on the Top side, B: Mounted on the Bottom side) S.=Surface mount

[LOGIC UNIT]

REF NO.	PARTS NO.	DESCRIPTION	M.	H/V LOCATION
IC1	1190003230	S.IC FGS4ER-PX-112	T	18.2/24.1
IC2	1120003020	S.IC MAX3221PWR	B	35.5/37.4
IC3	1140015870	S.IC M24M01-RMN6TP	B	61.0/5.8
IC4	1130015740	S.IC S-35390A-IBT1G	B	71.6/12.5
IC5	1140015860	S.IC R5F56106WNBG	T	7.5/22.3
IC7	1140015870	S.IC M24M01-RMN6TP	B	22.9/4.1
IC8	1130014260	S.IC SN74LVC2GU04DCKR	B	54.9/37.9
IC9	1110007430	S.IC S-812C33AJA-C2N-T2 G	B	39.2/34.2
IC10	6910022370	S.DC TPS62400DRCR	B	73.3/9.0
IC11	1180003760	S.REG TLV7003DDCR	T	68.8/4.6
IC12	1110006740	S.IC LMV358IPWR	B	51.1/29.5
IC13	1110006740	S.IC LMV358IPWR	B	60.9/20.6
IC14	1110007630	S.IC NJM2783V-TE1-#ZZZH	B	58.5/28.5
IC15	1110007770	S.IC PCM3008T2K	B	50.0/20.5
IC16	1130009981	S.IC TC7W53FK(TE85LF)	B	65.9/43.8
IC17	1110006230	S.IC NJM2711F-TE1-#ZZZH	B	40.3/25.9
IC18	1140013290	S.IC TMS320VC5509AZHH	B	36.8/16.8
IC19	1110007660	S.IC NJM2746V-TE1-#ZZZH	T	76.6/44.0
IC20	1130015620	S.IC EN25Q40-100GIP <MSK>	B	37.3/7.4
IC21	1130015820	S.IC SN74AUP1T17DCKR	B	26.1/30.7
IC22	1110007820	S.IC S-80929CNPF-G8ZTFG	B	44.7/35.8
Q2	1590004070	S.TRA LDTC144EET1G <SLVJ>	B	13.0/26.8
Q3	1590004040	S.TRA LDTA123YET1G <SLVJ>	B	11.5/28.7
Q7	1590004070	S.TRA LDTC144EET1G <SLVJ>	B	12.5/22.8
Q8	1590004070	S.TRA LDTC144EET1G <SLVJ>	T	5.7/11.3
Q9	1590004070	S.TRA LDTC144EET1G <SLVJ>	T	5.7/9.3
Q10	1510000671	S.TRA 2SA1588-GR(TE85R F)	T	67.7/8.8
Q11	1510001100	S.TRA 2SA1832-GR(TE85RF)	B	50.6/37.4
Q12	1530003990	S.TRA 2SC4738-BL(TE85LF)	B	9.2/38.8
Q13	1530004000	S.TRA 2SC4738-GR(TE85LF)	B	56.3/40.5
Q15	1590004070	S.TRA LDTC144EET1G <SLVJ>	B	68.6/16.3
Q17	1590004070	S.TRA LDTC144EET1G <SLVJ>	B	65.5/18.0
Q18	1590004630	S.TRA DMC561050R	B	80.6/36.8
Q19	1590004050	S.TRA LDTA144EET1G <SLVJ>	B	29.9/26.8
Q20	1510001100	S.TRA 2SA1832-GR(TE85RF)	T	82.7/39.4
Q21	1590004100	S.TRA LDTC144TET1G <SLVJ>	B	69.0/42.6
Q23	1590004700	S.TRA DRC3143ZOL	B	18.0/3.6
Q24	1590004250	S.TRA DRC9143ZOL	T	7.0/1.3
Q25	1560001360	S.FET 2SK3019 TL	B	13.5/6.0
Eqv.	1560001840	S.FET 2SK3107-T1-AT		
D1	1750001810	S.DIO L1SS400T1G <SLVJ>	T	54.9/31.1
D2	1750001810	S.DIO L1SS400T1G <SLVJ>	T	53.0/32.8
D3	1750001810	S.DIO L1SS400T1G <SLVJ>	T	54.7/18.7
D4	1750001810	S.DIO L1SS400T1G <SLVJ>	T	53.0/16.3
D8	1750001810	S.DIO L1SS400T1G <SLVJ>	B	9.8/5.7
D11	1750001810	S.DIO L1SS400T1G <SLVJ>	T	53.0/31.6
D13	1750001810	S.DIO L1SS400T1G <SLVJ>	B	5.7/18.3
D14	1750001810	S.DIO L1SS400T1G <SLVJ>	B	5.7/16.1
D15	1750001810	S.DIO L1SS400T1G <SLVJ>	B	17.4/5.6
D16	1750001810	S.DIO L1SS400T1G <SLVJ>	B	81.4/10.3
D17	1750001810	S.DIO L1SS400T1G <SLVJ>	B	18.0/1.9
D18	1750000771	S.VAR HVC376BTRF-E	B	25.4/23.2
D20	1750001810	S.DIO L1SS400T1G <SLVJ>	B	39.2/31.1
D21	1750001810	S.DIO L1SS400T1G <SLVJ>	B	56.1/43.0
D22	1750001970	S.ZEN DZJ082MOL	B	10.7/42.4
D23	1750002020	S.DIO DA2S10100L	B	56.1/47.1
D24	1750001810	S.DIO L1SS400T1G <SLVJ>	B	8.7/43.4
D25	1750002170	S.DIO DB2S31400L	B	28.7/6.5
D26	1750001810	S.DIO L1SS400T1G <SLVJ>	T	67.1/48.3
D27	1750002170	S.DIO DB2S31400L	B	28.6/17.6
D28	1750002170	S.DIO DB2S31400L	T	40.0/17.6
D29	1750002170	S.DIO DB2S31400L	B	45.5/14.0
D30	1750002170	S.DIO DB2S31400L	T	40.0/16.4
D31	1790001850	S.VAR VC040205X150WP	B	72.2/42.6
D32	1790001960	S.VAR VC060303A100RP	T	13.1/2.0
D33	1790001960	S.VAR VC060303A100RP	T	21.2/1.6
D34	1750001810	S.DIO L1SS400T1G <SLVJ>	B	16.2/5.5
D35	1750001810	S.DIO L1SS400T1G <SLVJ>	B	13.9/2.5
X1	6050013250	S.XTA CR-925 (NX3215SA 32.768 kHz)	T	58.0/6.7
X2	6050013260	S.XTA CR-924 TAS-3225H 12.288 MHz	T	56.1/31.2
X3	6050013170	S.XTA CR-914 TTS18VSE-A11 12.288 MHz	B	33.0/24.9
L1	6200014260	S.COI LQM2MPN2R2NG0L	B	67.9/10.3
L2	6200014260	S.COI LQM2MPN2R2NG0L	B	75.0/18.4
L3	6200014260	S.COI LQM2MPN2R2NG0L	B	70.6/21.2
R2	7030005090	S.RES ERJ2GEJ 104 X (100K)	B	26.7/28.8
R4	7030005090	S.RES ERJ2GEJ 104 X (100K)	B	24.4/33.1
R5	7030005120	S.RES ERJ2GEJ 102 X (1K)	B	14.7/7.2
R6	7030005090	S.RES ERJ2GEJ 104 X (100K)	B	5.3/33.1
R7	7030010040	S.RES ERJ2GEJ-JPW	B	7.2/29.8
R8	7030005240	S.RES ERJ2GEJ 473 X (47K)	T	64.9/4.7
R9	7030005090	S.RES ERJ2GEJ 104 X (100K)	B	7.3/32.0
R10	7030005240	S.RES ERJ2GEJ 473 X (47K)	T	64.7/7.3
R11	7030005240	S.RES ERJ2GEJ 473 X (47K)	T	64.9/5.6
R12	7030005240	S.RES ERJ2GEJ 473 X (47K)	T	64.9/6.5
R13	7030005240	S.RES ERJ2GEJ 473 X (47K)	T	64.9/3.7
R14	7030004980	S.RES ERJ2GEJ 101 X (100)	B	36.7/43.3
R15	7030010040	S.RES ERJ2GEJ-JPW	B	7.3/33.6
R16	7030004980	S.RES ERJ2GEJ 101 X (100)	T	11.4/1.9
R17	7030008400	S.RES ERJ2GEJ 182 X (1.8K)	T	33.5/8.1
R18	7030008280	S.RES ERJ2GEJ 271 X (270)	B	26.2/4.7
R21	7030004980	S.RES ERJ2GEJ 101 X (100)	B	35.8/43.3
R22	7030004980	S.RES ERJ2GEJ 101 X (100)	T	19.1/2.3
R23	7030008400	S.RES ERJ2GEJ 182 X (1.8K)	T	33.5/9.0
R24	7030004980	S.RES ERJ2GEJ 101 X (100)	T	9.9/0.9
R25	7030008400	S.RES ERJ2GEJ 182 X (1.8K)	T	33.5/98.0
R27	7030008400	S.RES ERJ2GEJ 182 X (1.8K)	T	33.5/37.1
R29	7030005090	S.RES ERJ2GEJ 104 X (100K)	T	33.5/35.3
R30	7030005090	S.RES ERJ2GEJ 104 X (100K)	T	33.5/36.2
R33	7030007290	S.RES ERJ2GEJ 222 X (2.2K)	T	32.6/36.1
R34	7030007290	S.RES ERJ2GEJ 222 X (2.2K)	B	33.5/36.1
R35	7030005240	S.RES ERJ2GEJ 473 X (47K)	B	10.2/22.3
R36	7030005090	S.RES ERJ2GEJ 104 X (100K)	B	5.7/11.9
R37	7030005120	S.RES ERJ2GEJ 102 X (1K)	B	7.6/14.6
R38	7030005120	S.RES ERJ2GEJ 102 X (1K)	B	8.3/9.8
R39	7030005120	S.RES ERJ2GEJ 102 X (1K)	B	7.6/16.1
R40	7030005120	S.RES ERJ2GEJ 102 X (1K)	B	8.3/8.9
R41	7030005120	S.RES ERJ2GEJ 102 X (1K)	B	8.2/18.5
R42	7030005120	S.RES ERJ2GEJ 102 X (1K)	B	7.6/13.7
R43	7030005120	S.RES ERJ2GEJ 102 X (1K)	B	7.7/12.2
R44	7030005120	S.RES ERJ2GEJ 102 X (1K)	B	8.2/11.3
R45	7030005240	S.RES ERJ2GEJ 473 X (47K)	B	5.7/11.0
R46	7030005160	S.RES ERJ2GEJ 105 X (1M)	B	6.0/13.5
R47	7030005050	S.RES ERJ2GEJ 103 X (10K)	T	16.1/47.5
R48	7030005050	S.RES ERJ2GEJ 103 X (10K)	B	14.8/22.4
R49	7030005050	S.RES ERJ2GEJ 103 X (10K)	B	16.0/22.1
R50	7030005120	S.RES ERJ2GEJ 102 X (1K)	B	8.2/17.0
R51	7030005050	S.RES ERJ2GEJ 103 X (10K)	T	18.5/47.5
R52	7030005050	S.RES ERJ2GEJ 103 X (10K)	T	13.7/47.5
R53	7030005050	S.RES ERJ2GEJ 103 X (10K)	B	79.2/13.9
R54	7030005240	S.RES ERJ2GEJ 473 X (47K)	B	25.5/12.8
R55	7030005050	S.RES ERJ2GEJ 103 X (10K)	T	23.3/47.5
R56	7030005090	S.RES ERJ2GEJ 104 X (100K)	T	77.7/8.3
R57	7030005050	S.RES ERJ2GEJ 103 X (10K)	T	20.9/47.5
R58	7030005050	S.RES ERJ2GEJ 103 X (10K)	B	16.0/23.9
R59	7030005040	S.RES ERJ2GEJ 472 X (4.7K)	B	79.8/10.8
R60	7030005240	S.RES ERJ2GEJ 473 X (47K)	B	79.7/12.1
R61	7030005240	S.RES ERJ2GEJ 473 X (47K)	B	79.7/13.0
R63	7030005120	S.RES ERJ2GEJ 102 X (1K)	B	19.1/5.1
R64	7030005120	S.RES ERJ2GEJ 102 X (1K)	B	7.2/6.5
R65	7030008260	S.RES RR0510P-393-D (39K)	B	11.8/24.5
R66	7030005090	S.RES ERJ2GEJ 104 X (100K)	B	6.3/6.1
R68	7030008410	S.RES ERJ2GEJ 392 X (3.9K)	B	10.2/23.2
R69	7030005050	S.RES ERJ2GEJ 103 X (10K)	B	46.3/35.9
R70	7510001770	S.THE NTCG10 4LH 473JT	B	6.0/7.3
R71	7030010080	S.RES ERJ2RHD 1003X (100K)	B	6.1/8.2
R72	7030007270	S.RES ERJ2GEJ 151 X (150)	T	3.4/5.2
R73	7030007280	S.RES ERJ2GEJ 331 X (330)	T	5.5/7.9
R74	7030005530	S.RES ERJ2GEJ 100 X (10)	B	18.1/22.4
R75	7030005160	S.RES ERJ2GEJ 105 X (1M)	B	19.3/22.0
R76	7030005090	S.RES ERJ2GEJ 104 X (100K)	B	26.7/24.9
R77	7030008010	S.RES ERJ2GEJ 123 X (12K)	B	25.5/21.8
R79	7030005240	S.RES ERJ2GEJ 473 X (47K)	B	25.4/20.6
R80	7030005240	S.RES ERJ2GEJ 473 X (47K)	B	20.0/7.3
R84	7030004980	S.RES ERJ2GEJ 101 X (100)	B	25.5/17.3
R85	7030005110	S.RES ERJ2GEJ 224 X (220K)	T	65.9/7.7
R86	7030008010	S.RES ERJ2GEJ 123 X (12K)	T	64.5/11.1
R88	7030005090	S.RES ERJ2GEJ 104 X (100K)	B	57.5/37.2
R90	7030005090	S.RES ERJ2GEJ 104 X (100K)	B	55.0/36.0
R92	7030010040	S.RES ERJ2GEJ-JPW	B	25.5/6.9
R94	7030005240	S.RES ERJ2GEJ 473 X (47K)	B	19.7/3.9
R95	7030005040	S.RES ERJ2GEJ 472 X (4.7K)	B	19.1/6.0
R97	7030005240	S.RES ERJ2GEJ 473 X (47K)	B	49.0/37.7
R98	7030005090	S.RES ERJ2GEJ 104 X (100K)	B	12.1/41.1
R99	7030005120	S.RES ERJ2GEJ 102 X (1K)	B	11.5/38.6
R100	7030005820	S.RES RR0510P-103-D (10K)	B	52.2/37.5
R101	7030011880	S.RES RR0510P-183-D (18K)	B	53.1/37.5
R102	7030005240	S.RES ERJ2GEJ 473 X (47K)	B	9.0/40.5
R103	7030005050	S.RES ERJ2GEJ 103 X (10K)	B	9.0/42.3
R104	7030008010	S.RES ERJ2GEJ 123 X (12K)	B	57.7/39.1
R105	7030005120	S.RES ERJ2GEJ 102 X (1K)	B	56.1/45.0
R107	7030010010	S.RES ERJ2RKF 334 X (330K)	B	5.2/43.6
R108	7030007610	S.RES RR0510P-683-D (68K)	B	5.2/45.3
R109	7030005230	S.RES ERJ2GEJ 334 X (330K)	B	61.7/36.7
R111	7030005240	S.RES ERJ2GEJ 473 X (47K)	B	59.7/34.3
R112	7030005040	S.RES ERJ2GEJ 472 X (4.7K)	B	60.2/33.1
R113	7030005010	S.RES ERJ2GEJ 681 X (680)	B	61.1/35.5
R114	7030012270	S.RES ERJ2RKD 1203X (120K)	B	74.7/11.8
R115	7030012270	S.RES ERJ2RKD 1203X (120K)	B	75.6/6.5
R116	7030012270	S.RES ERJ2RKD 1203X (120K)	B	75.1/5.3
R117	7030012270	S.RES ERJ2RKD 1203X (120K)	B	74.5/6.5
R118	7030007340	S.RES ERJ2GEJ 153 X (15K)	B	61.1/32.2
R119	7030005240	S.RES ERJ2GEJ 473 X (47K)	B	54.7/33.4
R120	7030007350	S.RES ERJ2GEJ 393 X (39K)	B	53.4/30.0
R121	7030010020	S.RES ERJ2RKF 1503X (150K)	B	75.9/12.0
R122	7030008310	S.RES ERJ2GEJ 564 X (560K)	B	64.0/31.7
R124	7030005100	S.RES ERJ2GEJ 154 X (150K)	B	48.6/30.9
R125	7030005050	S.RES ERJ2GEJ 103 X (10K)	B	47.7/29.3
R126	7030005090	S.RES ERJ2GEJ 104 X (100K)	B	48.6/32.6
R127	7030005600	S.RES ERJ2GEJ 273 X (27K)	B	50.3/34.7
R128	7030005240	S.RES ERJ2GEJ 473 X (47K)	B	57.8/35.0
R130	7030004980	S.RES ERJ2GEJ 101 X (100)	B	53.8/31.7
R131	7030004980	S.RES ERJ2GEJ 101 X (100)	B	57.7/22.3
R132	7030005090	S.RES ERJ2GEJ 104 X (100K)	B	54.4/24.8
R133	7030005240	S.RES ERJ2GEJ 473 X (47K)	B	64.8/22.8
R134	7030005100	S.RES ERJ2GEJ 154 X (150K)	B	63.9/22.8
R135	7030005050	S.RES ERJ2GEJ 103 X (10K)	B	65.8/19.7
R136	7030005050	S.RES ERJ2GEJ 103 X (10K)	B	

[LOGIC UNIT]

REF NO.	PARTS NO.	DESCRIPTION	M.	H/V LOCATION
R151	7030005240	S.RES ERJ2GEJ 473 X (47K)	B	64.6/28.6
R152	7030005120	S.RES ERJ2GEJ 102 X (1K)	B	49.1/24.7
R153	7030010040	S.RES ERJ2GEJ-JPW	B	64.0/29.8
R154	7030009290	S.RES ERJ2GEJ 562 X (5.6K)	B	56.5/22.6
R155	7030005240	S.RES ERJ2GEJ 473 X (47K)	B	64.0/26.5
R156	7030010040	S.RES ERJ2GEJ-JPW	B	31.1/9.8
R157	7030005100	S.RES ERJ2GEJ 154 X (150K)	B	64.0/27.4
R158	7030004980	S.RES ERJ2GEJ 101 X (100)	B	47.7/26.0
R159	7030005030	S.RES ERJ2GEJ 152 X (1.5K)	B	47.9/24.4
R160	7030004980	S.RES ERJ2GEJ 101 X (100)	B	52.3/24.1
R161	7030005050	S.RES ERJ2GEJ 103 X (10K)	T	33.5/21.5
R162	7030005720	S.RES ERJ2GEJ 563 X (56K)	B	62.8/30.3
R163	7030005090	S.RES ERJ2GEJ 104 X (100K)	B	39.3/23.5
R164	7030005090	S.RES ERJ2GEJ 104 X (100K)	B	33.0/5.4
R165	7030005090	S.RES ERJ2GEJ 104 X (100K)	B	43.8/17.7
R166	7030007340	S.RES ERJ2GEJ 153 X (15K)	B	64.0/30.8
R167	7030005090	S.RES ERJ2GEJ 104 X (100K)	B	43.9/20.6
R168	7030005240	S.RES ERJ2GEJ 473 X (47K)	B	36.0/23.5
R169	7410001140	S.ARR EXB28V104JX	B	28.8/15.5
R171	7030005240	S.RES ERJ2GEJ 473 X (47K)	T	33.5/23.4
R172	7030005090	S.RES ERJ2GEJ 104 X (100K)	B	29.4/12.9
R173	7030005090	S.RES ERJ2GEJ 104 X (100K)	B	29.4/13.8
R174	7030005050	S.RES ERJ2GEJ 103 X (10K)	B	53.8/28.7
R175	7030005240	S.RES ERJ2GEJ 473 X (47K)	B	51.6/16.9
R176	7030005090	S.RES ERJ2GEJ 104 X (100K)	T	33.5/25.2
R177	7030005240	S.RES ERJ2GEJ 473 X (47K)	B	43.9/19.7
R178	7030005090	S.RES ERJ2GEJ 104 X (100K)	T	33.5/26.3
R179	7030005090	S.RES ERJ2GEJ 104 X (100K)	B	40.9/23.5
R180	7030005240	S.RES ERJ2GEJ 473 X (47K)	B	49.4/16.8
R181	7030005160	S.RES ERJ2GEJ 105 X (1M)	T	65.1/45.5
R184	7030010010	S.RES ERJ2RKF 334 X (330K)	T	65.1/46.4
R185	7030005230	S.RES ERJ2GEJ 334 X (330K)	T	79.1/45.3
R186	7030005050	S.RES ERJ2GEJ 103 X (10K)	T	79.2/46.9
R187	7030010040	S.RES ERJ2GEJ-JPW	B	31.8/8.9
R188	7030005090	S.RES ERJ2GEJ 104 X (100K)	T	33.5/24.3
R189	7030004980	S.RES ERJ2GEJ 101 X (100)	B	45.2/19.3
R190	7030007340	S.RES ERJ2GEJ 153 X (15K)	B	65.2/47.9
R191	7030005220	S.RES ERJ2GEJ 223 X (22K)	B	72.9/44.3
R192	7030007290	S.RES ERJ2GEJ 222 X (2.2K)	B	39.4/29.0
R193	7030004980	S.RES ERJ2GEJ 101 X (100)	B	37.8/28.7
R195	7030005240	S.RES ERJ2GEJ 473 X (47K)	B	37.2/25.8
R196	7030005240	S.RES ERJ2GEJ 473 X (47K)	B	38.1/25.8
R197	7030005120	S.RES ERJ2GEJ 102 X (1K)	B	74.7/45.0
R199	7030005090	S.RES ERJ2GEJ 104 X (100K)	B	43.9/13.1
R200	7030005240	S.RES ERJ2GEJ 473 X (47K)	B	36.3/25.7
R204	7030004970	S.RES ERJ2GEJ 470 X (47)	B	40.7/28.9
R205	7030005090	S.RES ERJ2GEJ 104 X (100K)	B	78.3/45.2
R206	7030005090	S.RES ERJ2GEJ 104 X (100K)	T	33.6/19.8
R207	7030005090	S.RES ERJ2GEJ 104 X (100K)	B	76.7/45.5
R208	7410001140	S.ARR EXB28V104JX	B	28.2/19.6
R209	7030005090	S.RES ERJ2GEJ 104 X (100K)	B	76.6/44.6
R210	7030005050	S.RES ERJ2GEJ 103 X (10K)	B	76.3/46.7
R211	7030005050	S.RES ERJ2GEJ 103 X (10K)	B	73.6/46.7
R212	7030005030	S.RES ERJ2GEJ 152 X (1.5K)	B	80.8/38.6
R214	7410001140	S.ARR EXB28V104JX	B	44.3/10.6
R215	7030005090	S.RES ERJ2GEJ 104 X (100K)	B	28.9/4.6
R216	7030008370	S.RES ERJ2GEJ 561 X (560)	B	80.8/39.5
R217	7030005240	S.RES ERJ2GEJ 473 X (47K)	B	29.2/7.8
R218	7030010040	S.RES ERJ2GEJ-JPW	B	79.2/39.9
R219	7030005240	S.RES ERJ2GEJ 473 X (47K)	B	32.7/27.3
R220	7030005050	S.RES ERJ2GEJ 103 X (10K)	B	77.7/40.8
R221	7030005090	S.RES ERJ2GEJ 104 X (100K)	B	28.9/5.5
R222	7030005240	S.RES ERJ2GEJ 473 X (47K)	B	33.0/8.6
R223	7410001140	S.ARR EXB28V104JX	B	48.1/11.5
R224	7030005240	S.RES ERJ2GEJ 473 X (47K)	B	41.5/7.8
R225	7030005040	S.RES ERJ2GEJ 472 X (4.7K)	B	43.3/6.2
R226	7030005120	S.RES ERJ2GEJ 102 X (1K)	B	49.7/28.3
R227	7030005120	S.RES ERJ2GEJ 102 X (1K)	B	76.8/41.0
R228	7030007290	S.RES ERJ2GEJ 222 X (2.2K)	T	80.0/39.7
R229	7030005240	S.RES ERJ2GEJ 473 X (47K)	B	42.4/7.8
R230	7030005040	S.RES ERJ2GEJ 472 X (4.7K)	B	42.4/6.2
R231	7030005090	S.RES ERJ2GEJ 104 X (100K)	T	33.5/11.9
R232	7030005050	S.RES ERJ2GEJ 103 X (10K)	T	83.7/37.9
R233	7030005090	S.RES ERJ2GEJ 104 X (100K)	T	33.5/18.5
R234	7030005110	S.RES ERJ2GEJ 224 X (220K)	T	83.6/40.8
R235	7030005090	S.RES ERJ2GEJ 104 X (100K)	T	33.5/17.6
R236	7030005090	S.RES ERJ2GEJ 104 X (100K)	T	33.5/13.7
R237	7030010040	S.RES ERJ2GEJ-JPW	B	73.4/43.1
R238	7030005090	S.RES ERJ2GEJ 104 X (100K)	B	33.5/12.8
R239	7030007290	S.RES ERJ2GEJ 222 X (2.2K)	B	73.4/42.2
R240	7030005040	S.RES ERJ2GEJ 472 X (4.7K)	B	44.3/4.5
R241	7030005000	S.RES ERJ2GEJ 471 X (470)	T	84.2/39.2
R242	7030005220	S.RES ERJ2GEJ 223 X (22K)	B	71.0/43.1
R244	7030007320	S.RES ERJ2GEJ 225 X (2.2M)	B	14.9/6.0
R246	7030005090	S.RES ERJ2GEJ 104 X (100K)	B	43.9/18.8
R247	7030005090	S.RES ERJ2GEJ 104 X (100K)	B	42.5/23.5
R248	7030005240	S.RES ERJ2GEJ 473 X (47K)	T	33.5/22.4
R249	7030005240	S.RES ERJ2GEJ 473 X (47K)	B	25.5/16.4
R250	7030005240	S.RES ERJ2GEJ 473 X (47K)	B	25.5/15.5
R251	7030005240	S.RES ERJ2GEJ 473 X (47K)	B	25.7/19.2
R254	7030005240	S.RES ERJ2GEJ 473 X (47K)	B	68.2/8.2
R255	7030010040	S.RES ERJ2GEJ-JPW	B	44.6/33.7
R256	7030010040	S.RES ERJ2GEJ-JPW	B	47.0/24.4
R260	7030005090	S.RES ERJ2GEJ 104 X (100K)	B	48.5/16.8
R261	7030005090	S.RES ERJ2GEJ 104 X (100K)	B	45.5/16.9
R262	7030005090	S.RES ERJ2GEJ 104 X (100K)	B	48.5/17.2
R263	7030005090	S.RES ERJ2GEJ 104 X (100K)	B	47.6/16.8
R264	7030005090	S.RES ERJ2GEJ 104 X (100K)	B	25.3/33.2
R265	7030005090	S.RES ERJ2GEJ 104 X (100K)	T	33.5/10.1
R266	7030005090	S.RES ERJ2GEJ 104 X (100K)	B	43.9/14.9
R267	7030005090	S.RES ERJ2GEJ 104 X (100K)	B	47.9/14.9
R268	7030005090	S.RES ERJ2GEJ 104 X (100K)	B	48.9/15.0
R269	7030005090	S.RES ERJ2GEJ 104 X (100K)	B	47.0/14.9
R270	7030005090	S.RES ERJ2GEJ 104 X (100K)	T	33.5/16.7
R271	7030005090	S.RES ERJ2GEJ 104 X (100K)	B	46.8/10.0

Eqv.= This component is equivalent to the REF No. component listed above, and may be substituted on parts orders and repairs.

[LOGIC UNIT]

REF NO.	PARTS NO.	DESCRIPTION	M.	H/V LOCATION
R272	7030005090	S.RES ERJ2GEJ 104 X (100K)	T	33.5/11.0
R273	7030012260	S.RES ERJ2RKD 4703X (470K)	B	16.3/7.2
R274	7030012260	S.RES ERJ2RKD 4703X (470K)	B	14.2/4.2
R276	7030005050	S.RES ERJ2GEJ 103 X (10K)	B	55.7/23.8
R277	7030005040	S.RES ERJ2GEJ 472 X (4.7K)	B	77.1/42.6
R278	7030012320	S.RES ERJ2RKD 2203X (220K)	B	14.9/1.9
R279	7030010040	S.RES ERJ2GEJ-JPW	B	18.6/26.3
R280	7030011910	S.RES ERJ2GEJ 106 X (10M)	B	9.5/28.1
R281	7030003860	S.RES ERJ3GE JPW V	B	67.5/12.3
R282	7030010040	S.RES ERJ2GEJ-JPW	B	62.2/25.0
R283	7030005120	S.RES ERJ2GEJ 102 X (1K)	B	55.3/22.0
R284	7030005050	S.RES ERJ2GEJ 103 X (10K)	T	69.6/7.0
C1	Eqv. 4550008370	S.TAN TMCJ1C105MTRF	B	5.8/26.9
C2	Eqv. 4550008370	S.TAN TMCJ1C105MTRF	B	5.8/20.5
C3	Eqv. 4550008370	S.TAN TMCJ1C105MTRF	B	7.6/22.1
C4	Eqv. 4550008370	S.TAN TMCJ1C105MTRF	B	7.6/24.7
C5	Eqv. 4550008370	S.TAN TMCJ1C105MTRF	B	5.8/23.7
C7	4030017620	S.CER C1005 CH 1H 100C-T	B	45.0/41.4
C8	4550008370	S.TAN TMCJ1C105MTRF	B	5.8/28.5
C9	Eqv. 4550008370	S.TAN TMCJ1C105MTRF	B	5.8/25.3
C10	Eqv. 4550008370	S.TAN TMCJ1C105MTRF	B	5.8/22.1
C11	Eqv. 4550008370	S.TAN TMCJ1C105MTRF	B	7.6/27.3
C18	4030011810	S.CER C1608 JB 1A 224K-T	B	41.0/40.8
C19	4030011810	S.CER C1608 JB 1A 224K-T	B	42.2/40.8
C20	4030011810	S.CER C1608 JB 1A 224K-T	B	41.7/38.7
C21	4030011810	S.CER C1608 JB 1A 224K-T	B	41.7/37.5
C22	4030017620	S.CER C1005 CH 1H 100C-T	B	45.0/43.2
C24	4030017460	S.CER C1005 JB 1H 102K-T	B	11.5/26.8
C28	4030019120	S.CER GRM188B31E105KA75D	T	9.4/1.9
C29	4030017400	S.CER C1005 CH 1H 220J-T	T	54.8/33.2
C31	4030017460	S.CER C1005 JB 1H 102K-T	B	14.5/26.5
C33	4030017460	S.CER C1005 JB 1H 102K-T	B	3.4/43.6
C34	4030018910	S.CER C1608 JB 0J 475K-T	B	26.0/34.7
C35	4030016790	S.CER C1005 JB 1E 103K-T	B	9.6/29.8
C36	4030017460	S.CER C1005 JB 1H 102K-T	B	10.6/26.8
C38	4030017460	S.CER C1005 JB 1H 102K-T	B	4.3/43.6
C40	4030017460	S.CER C1005 JB 1H 102K-T	B	26.5/32.8
C41	4030017460	S.CER C1005 JB 1H 102K-T	B	3.2/34.0
C43	4030016930	S.CER C1005 JB 1A 104K-T	T	33.5/39.9
C44	4030017460	S.CER C1005 JB 1H 102K-T	B	2.1/43.6
C45	4030016790	S.CER C1005 JB 1E 103K-T	B	26.5/33.7
C48	4030016930	S.CER C1005 JB 1A 104K-T	B	19.7/1.9
C49	4030016790	S.CER C1005 JB 1E 103K-T	B	34.7/36.1
C51	4030017780	S.CER C1005 JB 1H 472K-T	B	10.4/8.9
C52	4030017760	S.CER C1005 JB 1H 222K-T	B	9.2/13.4
C53	4030017780	S.CER C1005 JB 1H 472K-T	B	9.8/18.2
C56	4030017780	S.CER C1005 JB 1H 472K-T	B	10.2/11.3
C58	4030017780	S.CER C1005 JB 1H 472K-T	B	9.5/9.9
C59	4030017780	S.CER C1005 JB 1H 472K-T	B	9.3/12.5
C61	4030017780	S.CER C1005 JB 1H 472K-T	B	9.2/14.9
C62	4030017780	S.CER C1005 JB 1H 472K-T	B	9.2/15.8
C64	4030017460	S.CER C1005 JB 1H 102K-T	B	25.5/14.6
C65	4030016930	S.CER C1005 JB 1A 104K-T	T	12.5/48.0
C67	4030017610	S.CER C1005 CH 1H 090C-T	B	83.6/13.5
C69	4030016930	S.CER C1005 JB 1A 104K-T	B	25.5/13.7
C72	4030017780	S.CER C1005 JB 1H 472K-T	B	8.1/6.5
C74	4030017780	S.CER C1005 JB 1H 472K-T	B	15.4/3.5
C76	4030018860	S.CER C1005 JB 0J 105K-T	T	83.6/10.8
C77	4030017460	S.CER C1005 JB 1H 102K-T	B	46.3/36.8
C78	4030018920	S.CER C1005 JB 1H 392K-T	B	13.3/24.4
C79	4030016790	S.CER C1005 JB 1E 103K-T	B	46.3/35.0
C80	4030017040	S.CER C1005 JB 1A 333K-T	B	10.2/24.1
C81	4030016930	S.CER C1005 JB 1A 104K-T	B	17.2/22.4
C83	4030017650	S.CER C1005 CH 1H 270J-T	B	17.7/25.3
C84	4030017730	S.CER C1005 JB 1H 471K-T	B	27.1/23.6
C85	4030016790	S.CER C1005 JB 1E 103K-T	B	26.7/25.8
C86	4030017570	S.CER C1005 CH 1H 040B-T	B	22.8/24.6
C87	4030017510	S.CER C1005 CH 1H 680J-T	B	23.2/23.3
C88	4030016790	S.CER C1005 JB 1E 103K-T	B	25.5/24.8
C89	4030017460	S.CER C1005 JB 1H 102K-T	T	5.3/12.8
C90	4030017460	S.CER C1005 JB 1H 102K-T	B	19.1/7.3
C91	4030016930	S.CER C1005 JB 1A 104K-T	B	25.5/18.2
C92	4030017460	S.CER C1005 JB 1H 102K-T	T	64.5/9.5
C94	4030016790	S.CER C1005 JB 1E 103K-T	B	25.5/8.6
C95	4030016930	S.CER C1005 JB 1A 104K-T	B	56.6/37.2
C96	4030017460	S.CER C		

[LOGIC UNIT]

REF NO.	PARTS NO.	DESCRIPTION	M.	H/V LOCATION
C114	4030017460	S.CER C1005 JB 1H 102K-T	B	57.8/34.1
C115	4030018890	S.CER C1005 JB 0J 224K-T	B	48.6/34.2
C116	4030019120	S.CER GRM188B31E105KA75D	T	71.8/6.0
C117	4030016930	S.CER C1005 JB 1A 104K-T	B	47.3/27.2
C118	4030017700	S.CER C1005 CH 1H 151J-T	B	50.3/33.8
C119	4030017460	S.CER C1005 JB 1H 102K-T	B	55.6/33.4
C120	4030019560	S.CER GRM21BB31C106KE15L	B	72.4/12.0
C121	4030016930	S.CER C1005 JB 1A 104K-T	B	60.9/23.1
C122	4030019460	S.CER C1608 JB 0J 106M-T	B	67.1/10.5
C123	4030017780	S.CER C1005 JB 1H 472K-T	B	55.3/25.0
C124	4030017920	S.CER C1005 JB 1A 683K-T	B	57.1/25.0
C125	4030017660	S.CER C1005 CH 1H 330J-T	B	51.6/25.3
C126	4030016930	S.CER C1005 JB 1A 104K-T	B	48.6/27.7
C129	4050000240	S.FEE NFM18PC104R1C3D	B	46.3/7.2
C130	4030018860	S.CER C1005 JB 0J 105K-T	B	60.1/25.3
C131	4030017460	S.CER C1005 JB 1H 102K-T	B	67.1/16.5
C132	4030016930	S.CER C1005 JB 1A 104K-T	B	46.8/29.3
C133	4030017460	S.CER C1005 JB 1H 102K-T	B	71.2/15.7
C134	4030016930	S.CER C1005 JB 1A 104K-T	B	46.2/4.7
C135	4030016930	S.CER C1005 JB 1A 104K-T	B	48.7/8.7
C136	4030016940	S.CER C1005 JB 1A 393K-T	B	63.5/18.0
C137	4030018080	S.CER C1005 JB 1H 182K-T	B	59.6/23.5
C138	4550007730	S.TAN TEESVJ 0J 106M8R	B	46.4/3.0
Eqv.	4550008380	S.TAN TMCJ0J106MTRF		
C139	4030016930	S.CER C1005 JB 1A 104K-T	B	65.5/28.6
C140	4550007730	S.TAN TEESVJ 0J 106M8R	B	47.6/7.7
Eqv.	4550008380	S.TAN TMCJ0J106MTRF		
C141	4030016930	S.CER C1005 JB 1A 104K-T	B	56.4/18.6
C142	4030017780	S.CER C1005 JB 1H 472K-T	B	64.0/25.6
C143	4030018860	S.CER C1005 JB 0J 105K-T	B	63.7/28.6
C144	4030018860	S.CER C1005 JB 0J 105K-T	B	62.8/28.6
C145	4030016790	S.CER C1005 JB 1E 103K-T	B	43.9/16.8
C146	4030016790	S.CER C1005 JB 1E 103K-T	B	30.0/23.0
C148	4030016790	S.CER C1005 JB 1E 103K-T	B	28.0/9.2
C149	4030019460	S.CER C1608 JB 0J 106M-T	B	28.7/11.2
C150	4030016930	S.CER C1005 JB 1A 104K-T	B	27.4/12.0
C151	4030017680	S.CER C1005 CH 1H 820J-T	B	62.8/26.9
C153	4030018860	S.CER C1005 JB 0J 105K-T	B	37.7/23.5
C155	4030020120	S.CER C1005 JB 0J 225M-T	B	46.1/24.1
C156	4030018860	S.CER C1005 JB 0J 105K-T	B	50.4/24.3
C158	4030016930	S.CER C1005 JB 1A 104K-T	B	54.6/22.9
C159	4030016930	S.CER C1005 JB 1A 104K-T	B	53.8/26.9
C160	4030016930	S.CER C1005 JB 1A 104K-T	B	55.5/19.7
C161	4030016930	S.CER C1005 JB 1A 104K-T	B	53.8/29.6
C162	4030018860	S.CER C1005 JB 0J 105K-T	B	53.8/27.8
C163	4030018860	S.CER C1005 JB 0J 105K-T	B	54.7/31.7
C164	4030018860	S.CER C1005 JB 0J 105K-T	B	43.9/15.9
C165	4030018910	S.CER C1608 JB 0J 475K-T	B	54.5/20.0
C166	4030018860	S.CER C1005 JB 0J 105K-T	B	43.9/14.0
C167	4030017440	S.CER C1005 CH 1H 221J-T	B	49.1/23.8
C168	4030016790	S.CER C1005 JB 1E 103K-T	B	37.8/24.4
C170	4030017440	S.CER C1005 CH 1H 221J-T	B	50.3/16.8
C171	4030017460	S.CER C1005 JB 1H 102K-T	B	67.0/47.6
C172	4030016790	S.CER C1005 JB 1E 103K-T	B	29.8/11.5
C173	4030018860	S.CER C1005 JB 0J 105K-T	B	65.6/46.7
C175	4030016930	S.CER C1005 JB 1A 104K-T	B	43.0/24.4
C177	4030016790	S.CER C1005 JB 1E 103K-T	T	65.1/47.3
C178	4550008090	S.TAN TCTU0J105K8R	T	78.3/47.4
C179	4030017380	S.CER C1005 CH 1H 050B-T	B	39.4/28.1
C180	4030017750	S.CER C1005 JB 1H 122K-T	B	73.8/44.3
C181	4030016930	S.CER C1005 JB 1A 104K-T	B	38.1/27.4
C182	4030016930	S.CER C1005 JB 1A 104K-T	T	74.8/47.2
C183	4030016930	S.CER C1005 JB 1A 104K-T	B	35.9/24.5
C184	4030018860	S.CER C1005 JB 0J 105K-T	B	73.3/45.5
C185	4030018910	S.CER C1608 JB 0J 475K-T	B	28.7/23.3
C186	4030017460	S.CER C1005 JB 1H 102K-T	B	37.2/27.4
C187	4030017620	S.CER C1005 CH 1H 100C-T	B	35.4/25.7
C189	4030016930	S.CER C1005 JB 1A 104K-T	B	29.7/21.7
C190	4030016960	S.CER C1005 JB 1E 183K-T	B	75.4/46.4
C191	4030016790	S.CER C1005 JB 1E 103K-T	B	41.6/28.9
C192	4030016930	S.CER C1005 JB 1A 104K-T	B	43.9/21.5
C193	4030016930	S.CER C1005 JB 1A 104K-T	B	41.5/6.2
C194	4030016790	S.CER C1005 JB 1E 103K-T	B	27.7/10.8
C195	4030017420	S.CER C1005 CH 1H 470J-T	B	43.6/25.3
C196	4550008090	S.TAN TCTU0J105K8R	B	77.8/44.0
C197	4030016930	S.CER C1005 JB 1A 104K-T	B	31.8/27.3
C198	4030016930	S.CER C1005 JB 1A 104K-T	B	30.1/23.9
C199	4030016930	S.CER C1005 JB 1A 104K-T	B	29.6/25.1
C201	4030018860	S.CER C1005 JB 0J 105K-T	B	76.2/42.6
C202	4030018860	S.CER C1005 JB 0J 105K-T	B	75.0/43.1
C203	4030017460	S.CER C1005 JB 1H 102K-T	B	75.3/41.9
C204	4030016950	S.CER C1005 JB 1A 473K-T	T	84.5/40.8
C205	4030016930	S.CER C1005 JB 1A 104K-T	B	32.7/10.0
C206	4550007090	S.TAN TEESVA 1A 226M8R	B	83.0/37.8
Eqv.	4550008160	S.TAN F931A226MAA		
C207	4030017400	S.CER C1005 CH 1H 220J-T	B	33.0/7.0
C208	4030016930	S.CER C1005 JB 1A 104K-T	T	5.4/1.2
C209	4030018860	S.CER C1005 JB 0J 105K-T	B	53.1/34.6
C210	4550008090	S.TAN TCTU0J105K8R	B	74.5/46.6
C211	4030016930	S.CER C1005 JB 1A 104K-T	B	26.3/27.6
C212	4030017460	S.CER C1005 JB 1H 102K-T	B	18.2/7.3
C213	4030017460	S.CER C1005 JB 1H 102K-T	B	13.1/7.5
C214	4030018860	S.CER C1005 JB 0J 105K-T	B	45.5/33.7
C217	4030017780	S.CER C1005 JB 1H 472K-T	B	15.9/1.9
C500	4050000240	S.FEE NFM18PC104R1C3D	B	10.7/31.1
C501	4030017430	S.CER C1005 CH 1H 101J-T	B	13.6/30.0
C502	4030017550	S.CER C1005 CH 1H 1R5B-T	B	79.3/15.4
C503	4030019460	S.CER C1608 JB 0J 106M-T	B	9.5/20.6
C504	4030019460	S.CER C1608 JB 0J 106M-T	B	45.4/32.3
C505	4030019460	S.CER C1608 JB 0J 106M-T	B	47.7/37.2
C506	4030019460	S.CER C1608 JB 0J 106M-T	B	51.6/35.8
C507	4030019460	S.CER C1608 JB 0J 106M-T	B	58.8/38.8
C508	4030019460	S.CER C1608 JB 0J 106M-T	B	26.5/7.5
C509	4030016930	S.CER C1005 JB 1A 104K-T	B	42.5/26.6
C510	4030016930	S.CER C1005 JB 1A 104K-T	B	53.7/16.5

Eqv.= This component is equivalent to the REF No. component listed above, and may be substituted on parts orders and repairs.

[LOGIC UNIT]

REF NO.	PARTS NO.	DESCRIPTION	M.	H/V LOCATION
C511	4030017440	S.CER C1005 CH 1H 221J-T	B	53.7/17.5
C512	4030017440	S.CER C1005 CH 1H 221J-T	B	45.5/16.3
C513	4030017440	S.CER C1005 CH 1H 221J-T	B	46.7/16.8
C514	4030017400	S.CER C1005 CH 1H 220J-T	B	44.7/23.3
C515	4030017440	S.CER C1005 CH 1H 221J-T	B	42.8/9.0
C516	4030017440	S.CER C1005 CH 1H 221J-T	B	41.4/9.4
C517	4030016930	S.CER C1005 JB 1A 104K-T	B	77.8/16.1
C520	4030018860	S.CER C1005 JB 0J 105K-T	B	58.9/17.8
C521	4030020450	S.CER C1005 JB 0J 475M-T	B	57.3/23.8
C522	4030020450	S.CER C1005 JB 0J 475M-T	B	71.0/42.2
C523	4030019460	S.CER C1608 JB 0J 106M-T	T	70.2/8.1
C524	4030019460	S.CER C1608 JB 0J 106M-T	B	67.3/14.0
C526	4030018860	S.CER C1005 JB 0J 105K-T	T	66.3/3.0
J1	6510025970	S.CON 41-002AA-R <MRF>	B	11.6/34.6
J2	6510028080	S.CON 27FHSY-RSM1-GAN-TB(LF)(SN)	T	4.9/24.8
J3	6510028170	S.CON SDHL-8BNS-K-363-A0-ETB(HF)	B	57.0/8.3
J4	6510024580	S.CON HSJ1621-019011	B	49.4/48.2
J5	6510027760	S.CON AXK6S50547YG	B	70.8/37.0
DS1	5040003550	S.LED NSSW208T	T	16.4/1.8
DS2	5040003500	S.LED HT-191 UYG-K828 <KOU>	T	45.1/8.4
DS3	5040003550	S.LED NSSW208T	T	24.4/1.8
DS4	5040003500	S.LED HT-191 UYG-K828 <KOU>	T	53.4/8.4
DS5	5040003500	S.LED HT-191 UYG-K828 <KOU>	T	45.1/41.2
DS6	5040003500	S.LED HT-191 UYG-K828 <KOU>	T	53.4/41.2
DS7	5040002670	S.LED CL-165HR/YG	T	1.2/9.5
DS10	5030003520	LCD BTG-12864ET-FBWD-N-G-A2 <VKHK>		
MC1	7700002850	MIC EM6022P-65B-G <HOR>		
S1	2260003300	S.SWI EVQPQH855	T	57.6/40.5
S2	2260003300	S.SWI EVQPQH855	T	49.2/41.2
S3	2260003300	S.SWI EVQPQH855	T	53.7/24.8
S4	2260003300	S.SWI EVQPQH855	T	49.2/8.4
S5	2260003300	S.SWI EVQPQH855	T	46.8/32.3
S6	2260003300	S.SWI EVQPQH855	T	46.8/24.8
S7	2260003300	S.SWI EVQPQH855	T	46.8/17.4
S8	2260003300	S.SWI EVQPQH855	T	57.6/9.1
S9	2260003300	S.SWI EVQPQH855	T	40.9/41.2
S10	2260003300	S.SWI EVQPQH855	T	39.9/24.8
S11	2260003300	S.SWI EVQPQH855	T	40.9/8.4
S12	2250000710	ENC F082EN7510W-1+C L20FX6 <SLVJ>		
BT1	3020000390	S.LIT ML414HIV01E	T	75.5/4.7
EP1	6910018460	S.BEA MMZ1005Y102C-T	B	56.1/48.9
EP2	6910018460	S.BEA MMZ1005Y102C-T	B	43.8/41.0
EP3	6910018460	S.BEA MMZ1005Y102C-T	B	43.8/43.7
EP4	6910016330	S.BEA MMZ1005S 601CT-S	B	12.7/31.1
EP5	6910018460	S.BEA MMZ1005Y102C-T	T	33.5/39.0
EP6	6910021630	S.BEA BLM18RK102SN1D	B	67.5/5.4
EP9	6910021630	S.BEA BLM18RK102SN1D	B	48.3/4.6
EP10	6910021630	S.BEA BLM18RK102SN1D	B	48.3/5.8
EP12	6910016330	S.BEA MMZ1005S 601CT-S	B	29.9/9.4
EP13	6910016330	S.BEA MMZ1005S 601CT-S	B	55.2/18.3
EP19	6910016330	S.BEA MMZ1005S 601CT-S	B	43.6/28.8
EP20	6910016330	S.BEA MMZ1005S 601CT-S	B	30.5/25.1

M.=Mounted side (T: Mounted on the Top side, B: Mounted on the Bottom side) S.=Surface mount

SECTION 7

MECHANICAL PARTS

[CHASSIS PARTS]

REF NO.	ORDER NO.	DESCRIPTION	QTY.
J1	6910015630	2682 ANT CONNECTOR <EIK>	1
SP1	2510001650	K028NA510-13 <OSC>	1
EP1	3310004270	AGA121204-S0-A6 <MRF>	1
MP1	8010022180	3322 CHASSIS 0	1
MP2	8210027110	3322 FRONT PANELASSEMBLY	1
MP6	8310078560	3322 WINDOW PLATE (A)	1
MP7	8610014360	KNOB N-397	1
MP8	8610014370	KNOB N-398	1
MP9	8930083070	3322 LENS	1
MP10	8930083080	3322 C-BUTTON	1
MP11	8930083090	3322 D-BUTTON	1
MP12	8210027090	3322 REFLECTOR	1
MP13	8930083100	3322 JACK CAP (TOT)	1
MP14	8930083110	3322 SD CAP (TOT)	1
MP15	8930083160	3322 KEYBOARD <SEP>	1
MP16	8930083120	3322 MAIN SEAL (TOT)	1
MP18	8930083140	3322 CONTACT RUBBER (TOT)	1
MP19	8930083670	O-RING (CL) (TOT)	1
MP20	8930083680	O-RING (CM) (TOT)	1
MP21	8830003670	VR NUT (AC)	1
MP22	8510020280	3322 SHIELD PLATE	1
MP23	8830003660	STEP NUT (M)	1
MP24	8930083420	3322 WHITE SHEET	1
MP25	8930083150	3322 WINDOW SHEET	1
MP26	8930083700	DOUBLE SIDE TAPE (BM)	1
MP27	8930083690	3322 GPS SPONGE	1
MP28*	8930083810	SPONGE (LJ)	1
MP30	8810011050	BT No. O M2X3 NI-ZC3	16
MP33	8810010850	PHBT B0 M2X8 SUS SSBC	2
MP35	8930068980	2905 VENT SHEET	1
MP36	8930069350	2905 MIC SEAL (TOP)S	1
MP37	8930058550	O-RING (AS)	1
MP38	8930055920	INSULATION PLATE GQ	1
MP39	8950004430	DOUBLE SIDE TAPE (O)	2
MP41	8930076440	3115 VENT SHEET	1
MP42	8930083880	O-RING (CK)	1
MP43*	8930058500	INSULATION PLATE HB	1
MP44	8930083900	INSULATION SHEET (MW)	1
MP45	8930083910	3322 LCD SHEET	1
MP47	8930084720	SPONGE (LP)	1
MP48	8930084600	SPONGE (LL)	2
MP49*	8930070590	SHIELD TAPE (S)	1
MP50	8930058500	INSULATION PLATE HB	1

[MAIN UNIT]

REF NO.	ORDER NO.	DESCRIPTION	QTY.
J2	6450000870	HEC2711-01-020	1
J3*	6510028130	AXK5S50047YG	1
J4	6510025880	TC38-108-01 <CFE>	1
J5	6450000131	HSJ1102-018540	1
S1*	2260003320	SKRTLAE010	1
S2	2260001900	SW-149 (SKHLLD)	1
MP1	8950007850	3322 CONTACT SPRING <CCP>	1
MP8*	8410002610	2888 PA HEATSINK Y835	1
MP9	6910022500	N041M0-01C000CR <CCP>	1
MP10	6910022500	N041M0-01C000CR <CCP>	1

[LOGIC UNIT]

REF NO.	ORDER NO.	DESCRIPTION	QTY.
J1*	6510025970	41-002AA-R <MRF>	1
J2*	6510028080	27FHSY-RSM1-GAN-TB (LF) (SN)	1
J3*	6510028170	SDHL-8BNS-K-363-A0-ETB (HF)	1
J4*	6510024580	HSJ1621-019011	1
J5*	6510027760	AXK6S50547YG	1
DS10	5030003520	BTG-12864ET-FBWD-N-G-A2 <VKHK>	1
MC1	7700002850	EM6022P-65B-G <HOR>	1
S1*	2260003300	EVQPQHB55	1
S2*	2260003300	EVQPQHB55	1
S3*	2260003300	EVQPQHB55	1
S4*	2260003300	EVQPQHB55	1
S5*	2260003300	EVQPQHB55	1
S6*	2260003300	EVQPQHB55	1
S7*	2260003300	EVQPQHB55	1
S8*	2260003300	EVQPQHB55	1
S9*	2260003300	EVQPQHB55	1
S10*	2260003300	EVQPQHB55	1
S11*	2260003300	EVQPQHB55	1
S12	2250000710	F082EN7510W-1+C L20FX6 <SLVJ>	1
BT1*	3020000390	ML414HIV01E	1

[ACCESSORIES]

REF NO.	ORDER NO.	DESCRIPTION	QTY.
EP1	6910018620	BLACK HANDY STRAP	1
EP2	3310002150	FA-S270C	1
EP3	(Optional)	BC-167SD [EUR]	1
	(Optional)	BC-167SD [ITR]	1
	(Optional)	BC-167SA [USA]	1
	(Optional)	BC-167SD [KOR]	1
	(Optional)	BC-167SA [EXP]	1
	(Optional)	BC-167SD [EXP-01]	1
	(Optional)	BC-167SV [AUS]	1
EP4	(Optional)	BP-271 EXP	1
MP1	(Optional)	MB-127	1

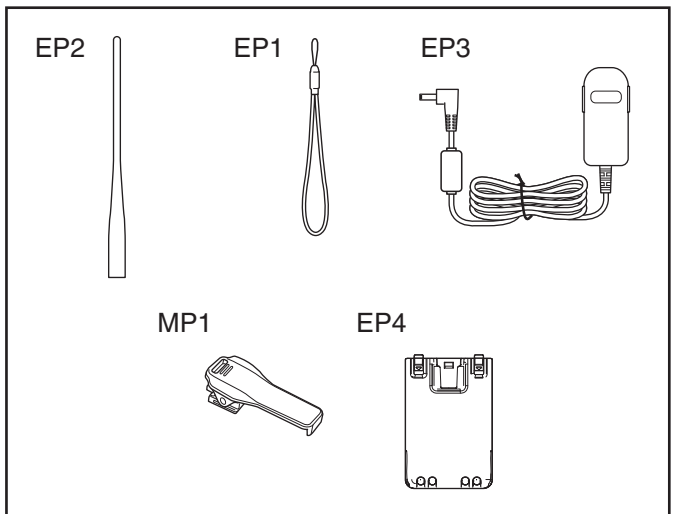

*: Refer to "BOARD LAYOUTS" for the location.

Screw abbreviations A, B0, BT: Self-tapping PH: Pan head ZK: Black NI-ZU: Nickel-Zinc SUS: Stainless

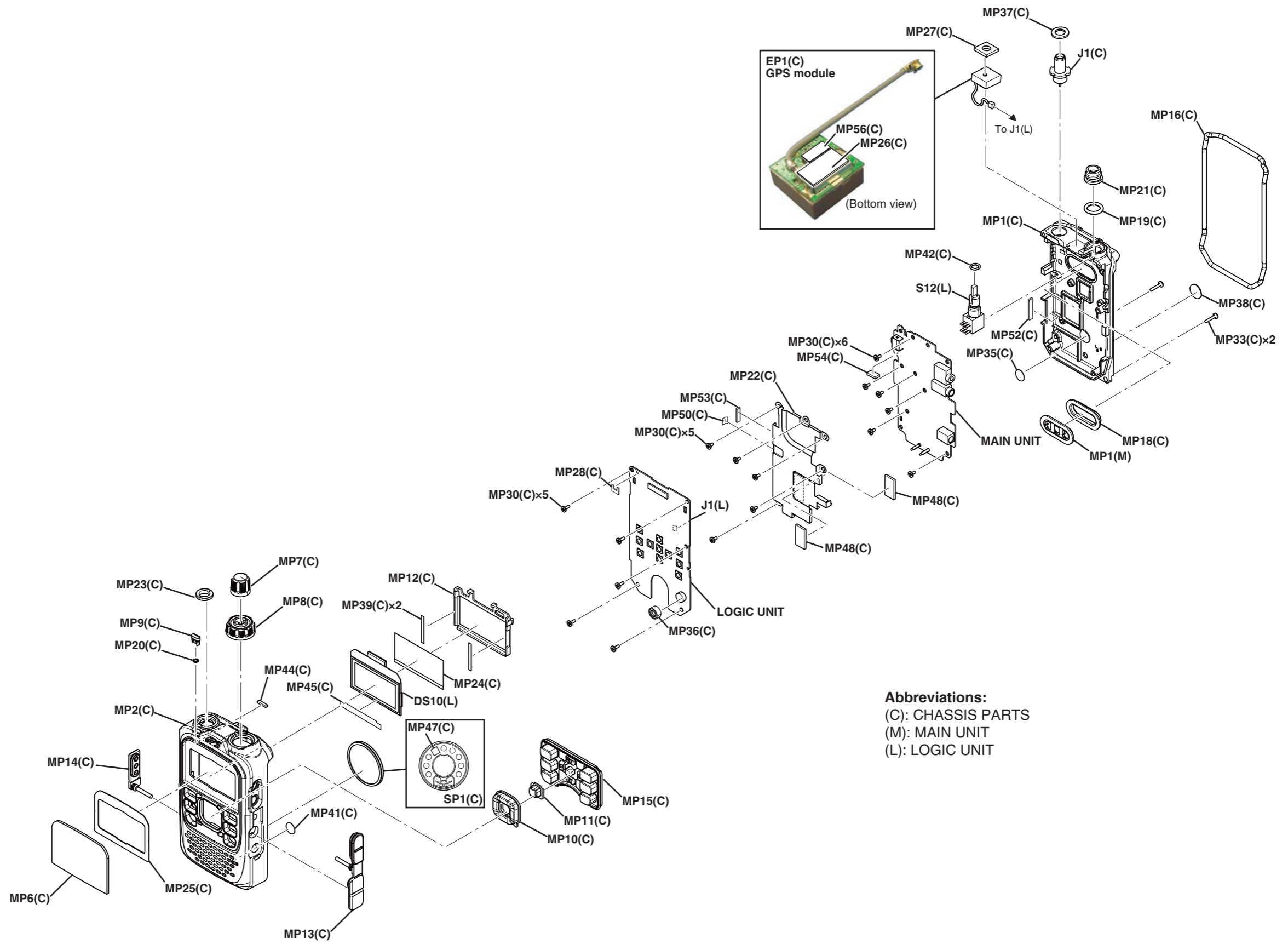

• LOGIC UNIT
(BOTTOM VIEW)

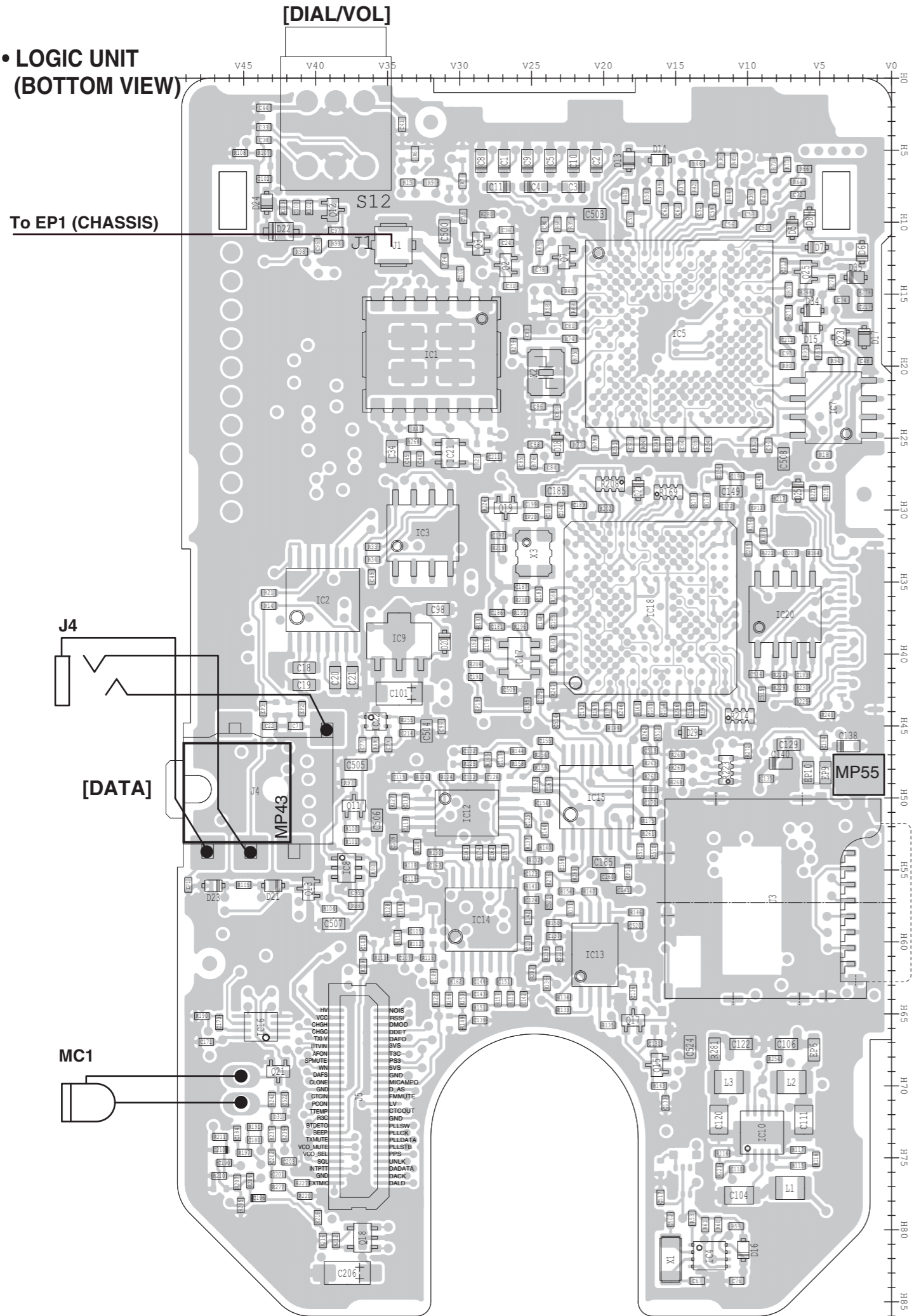

• MAIN UNIT
(BOTTOM VIEW)

The combination of this page and next page shows the top side and bottom side of actual P.C. board.

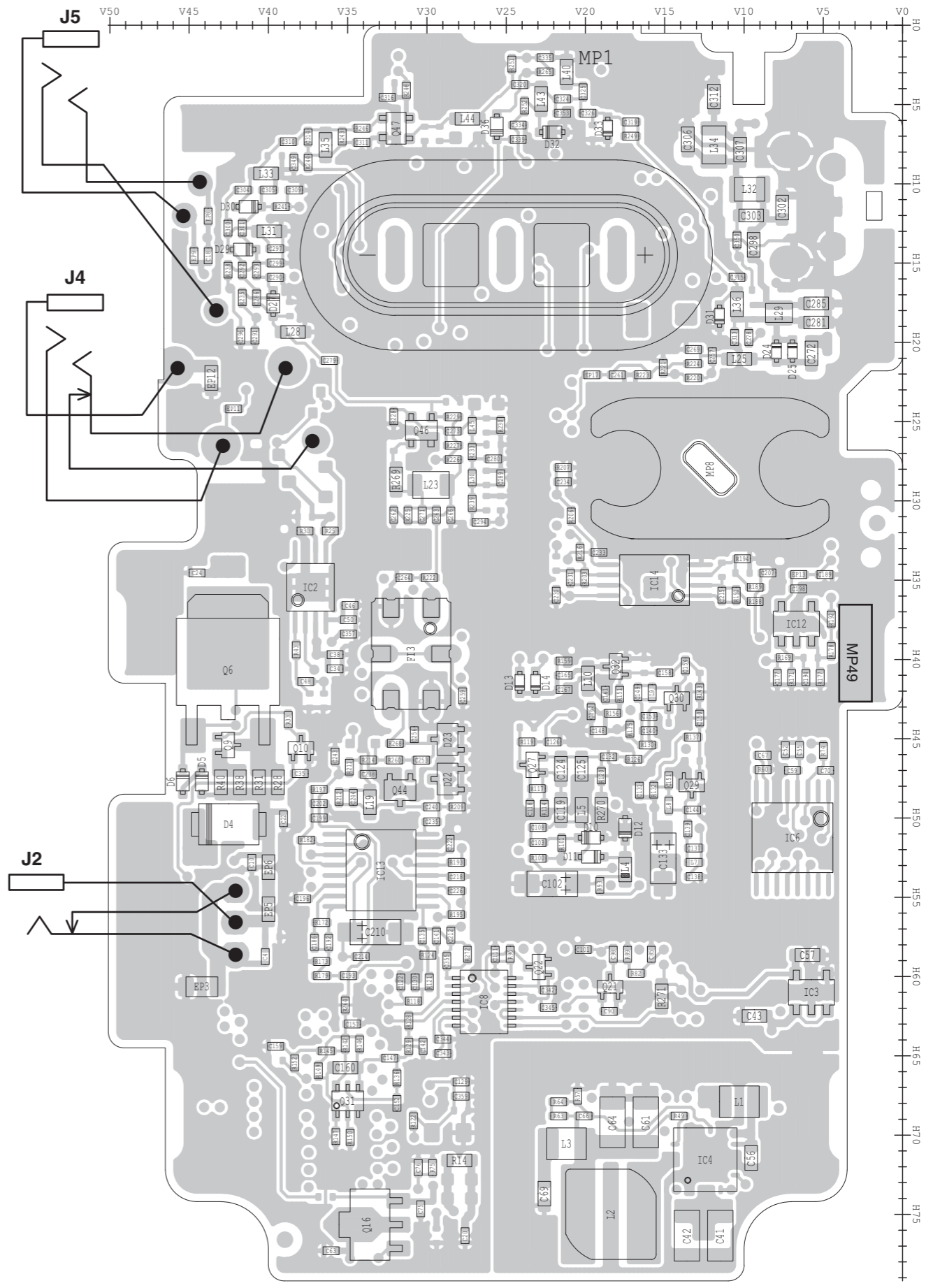

SECTION 10

BLOCK DIAGRAM

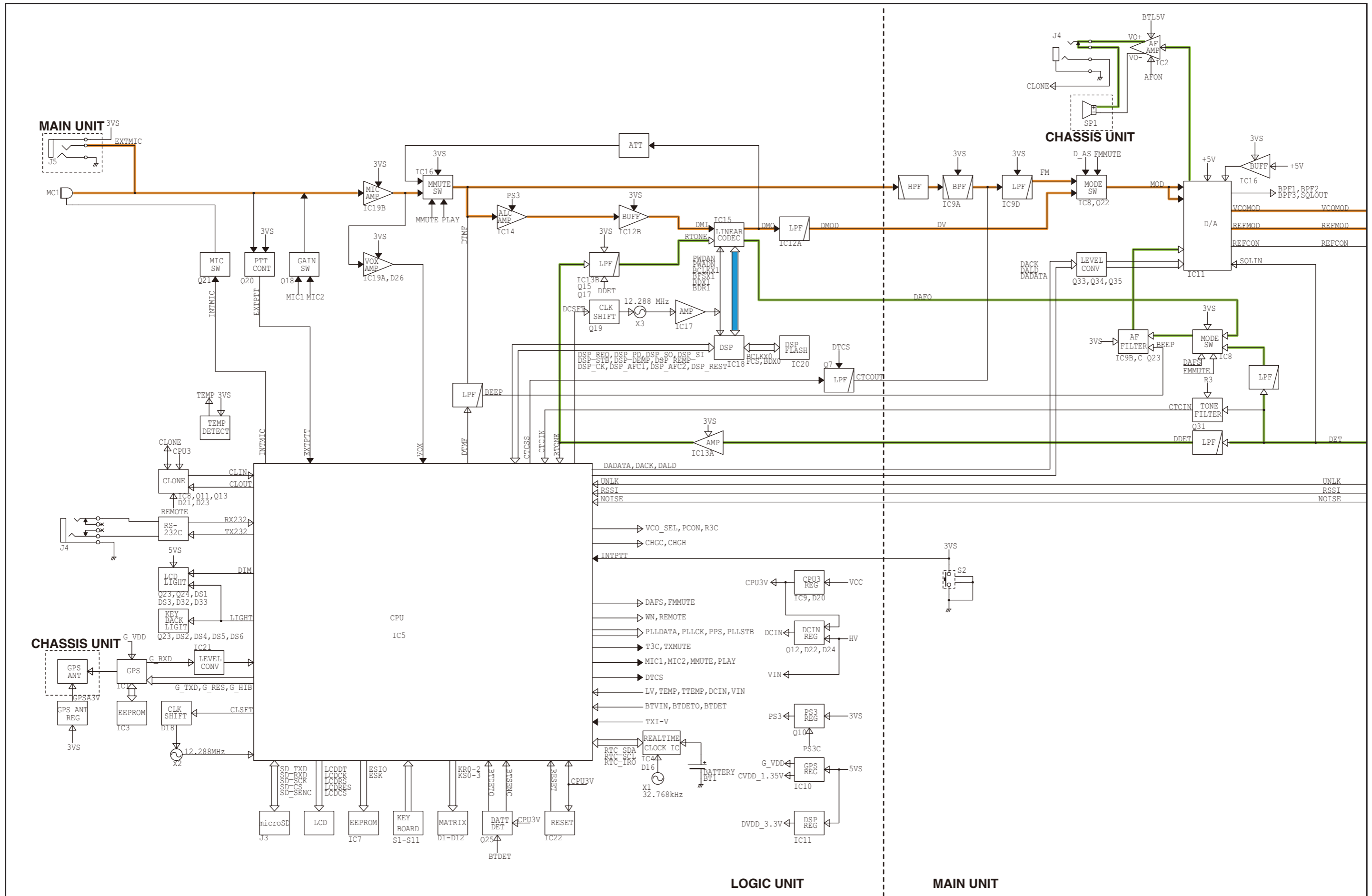

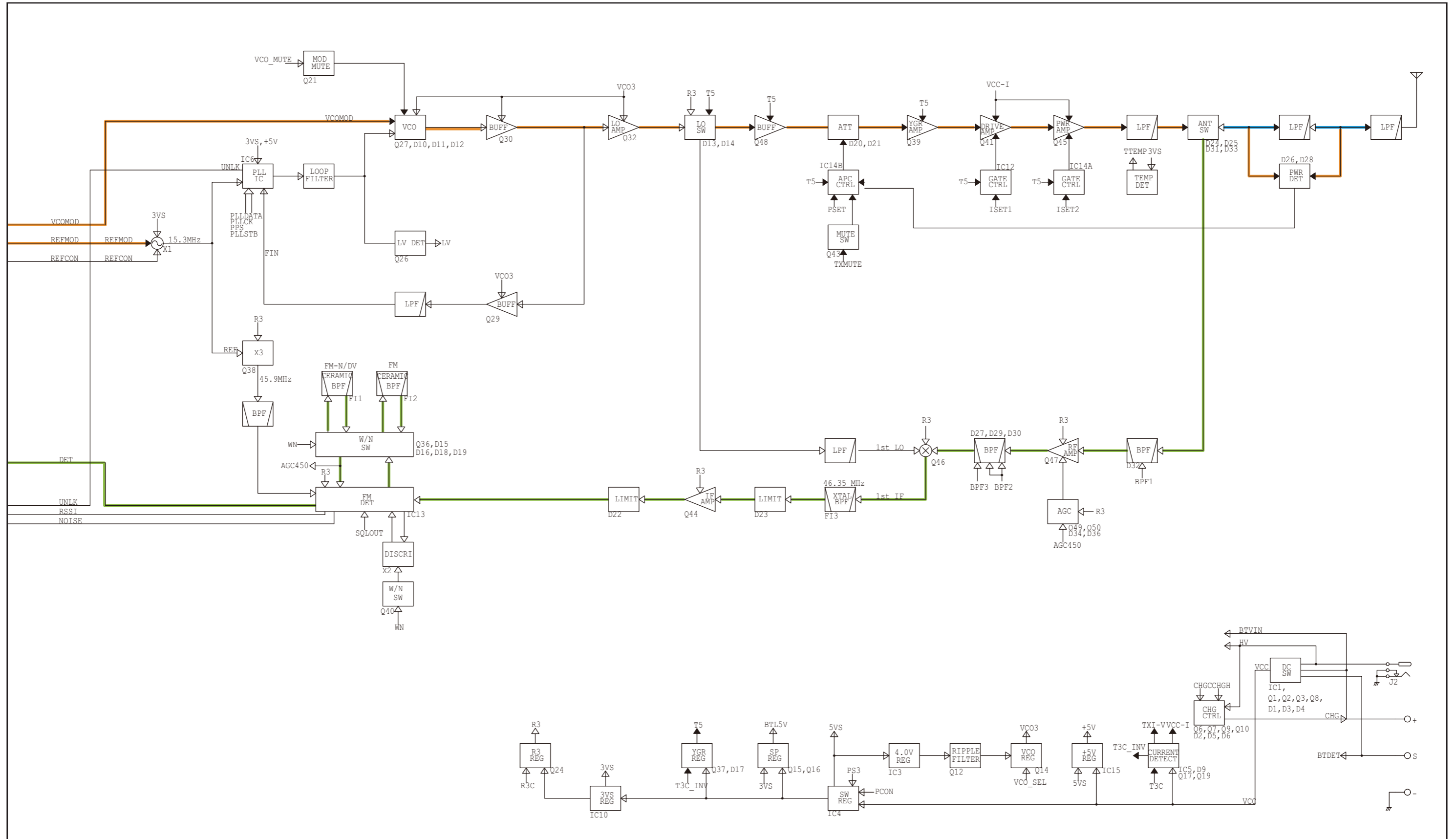

• LOGIC UNIT (1/2)

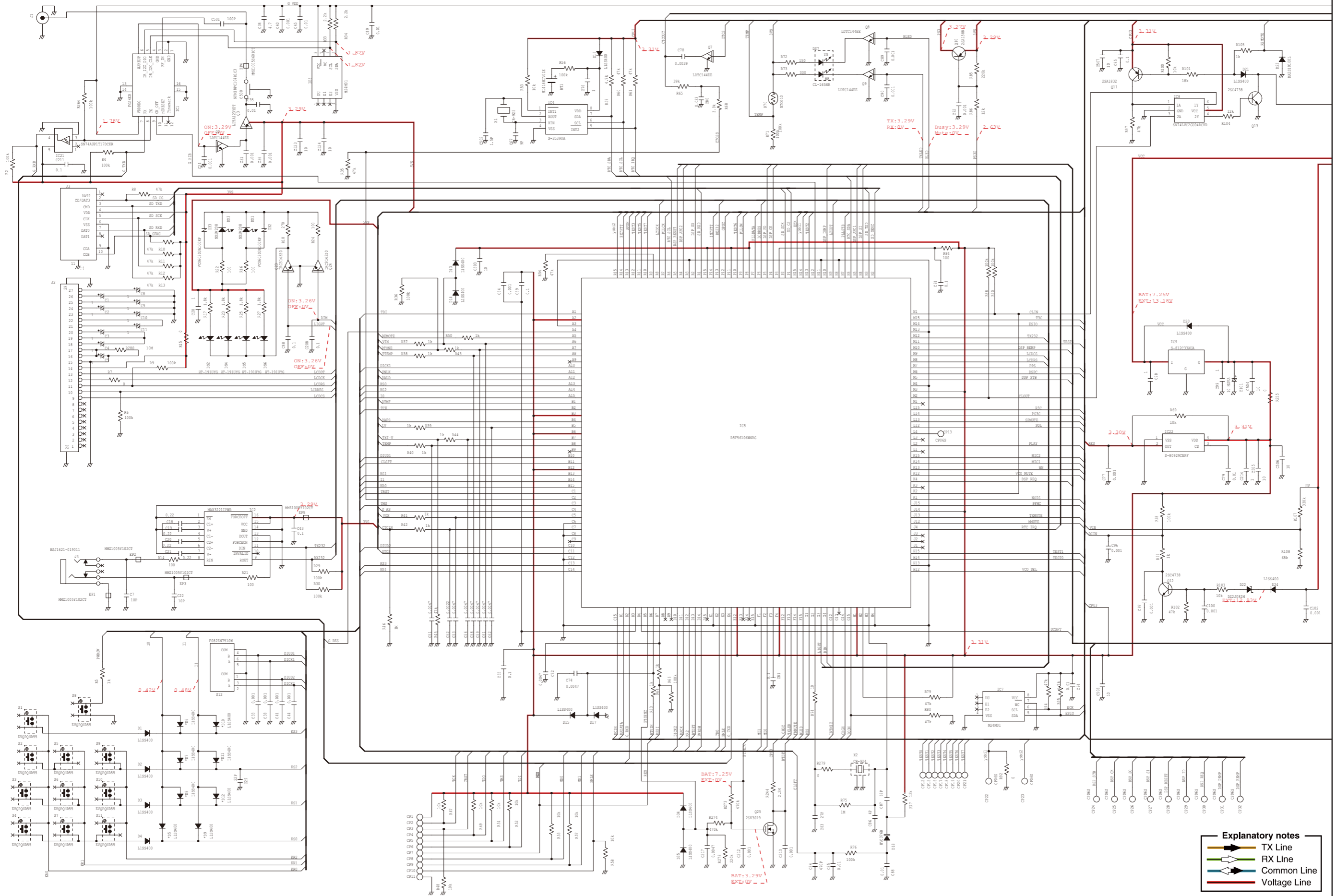

*: Refer to the PARTS LIST for the value and name of component.

• LOGIC UNIT (2/2)

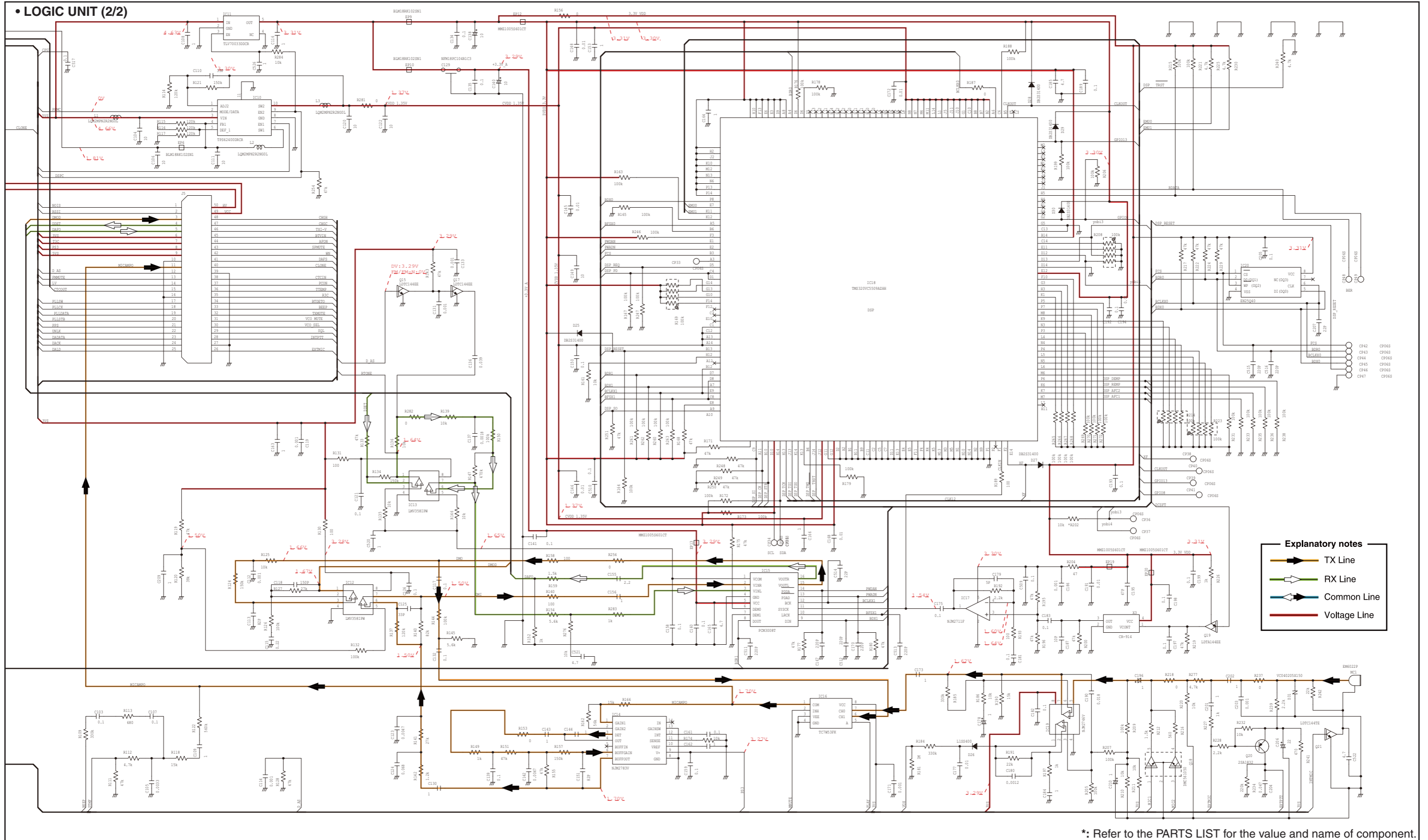

• MAIN UNIT (1/2)

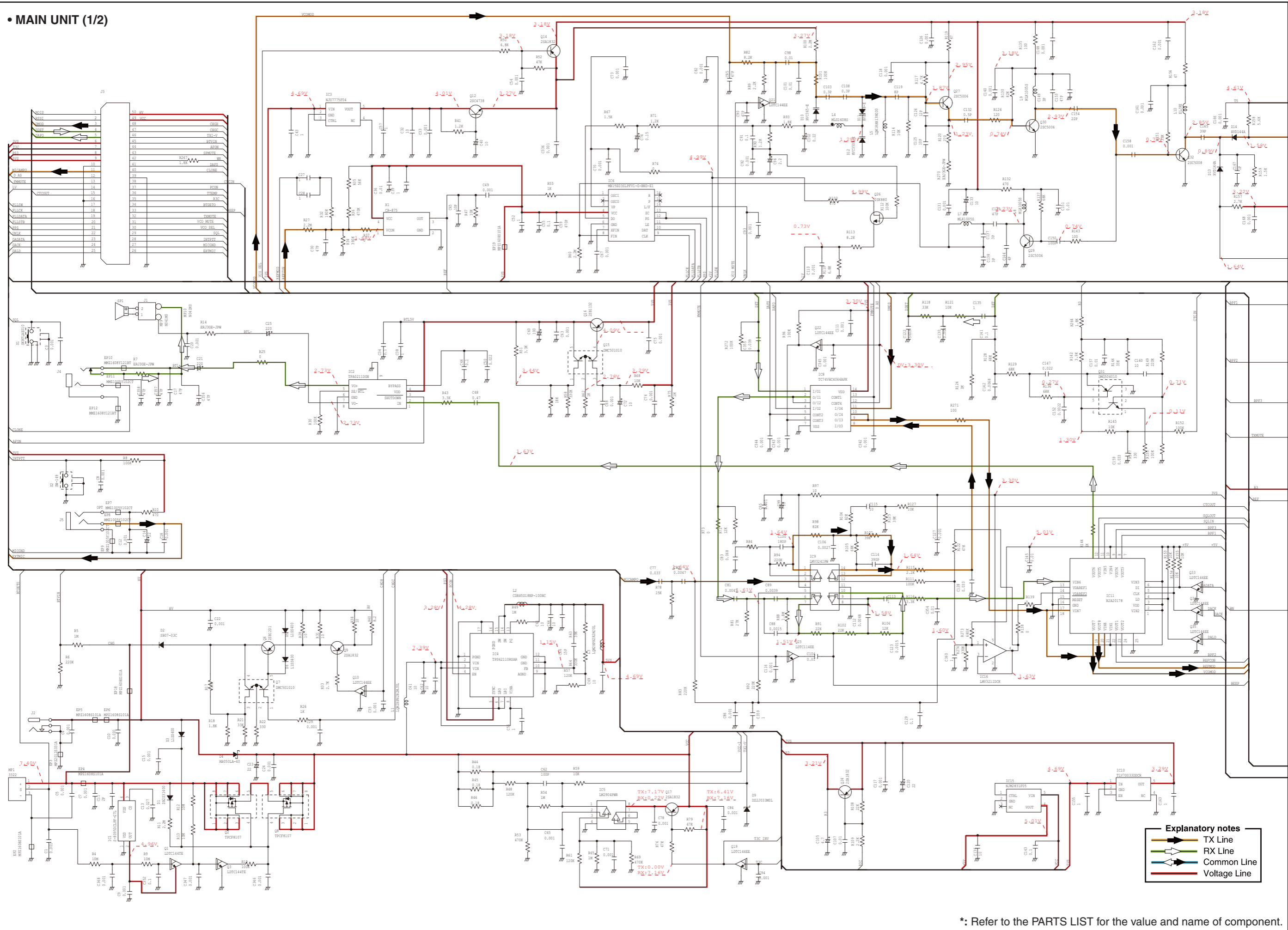

Explanatory notes

- TX Line
- RX Line
- Common Line
- Voltage Line

*: Refer to the PARTS LIST for the value and name of component.

• MAIN UNIT (2/2)

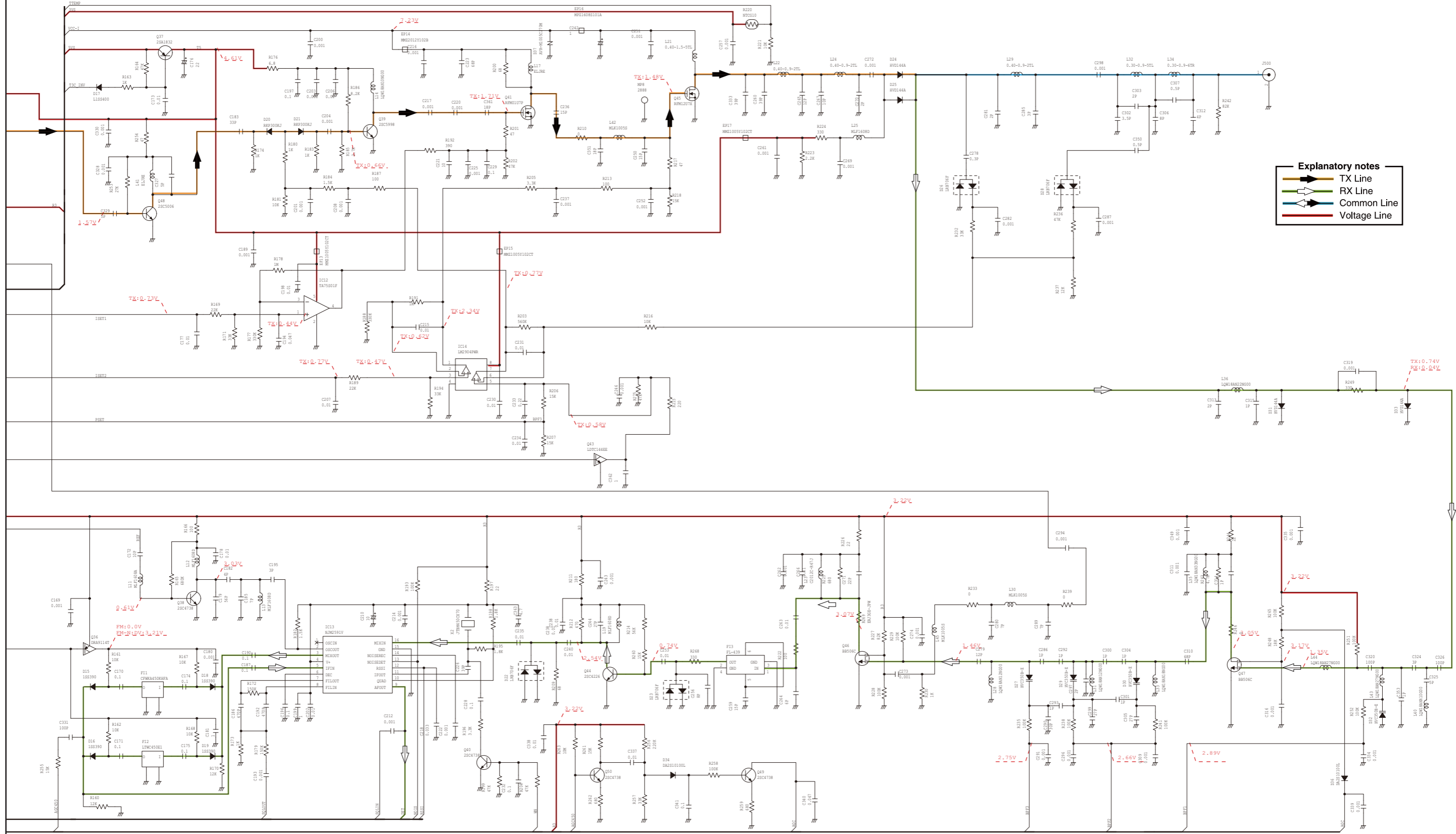

Explanatory notes
 TX Line
 RX Line
 Common Line
 Voltage Line

*: Refer to the PARTS LIST for the value and name of component.

Icom Inc.

1-1-32, Kamiminami, Hirano-ku, Osaka 547-0003, Japan
Phone : +81 (06) 6793 5302
Fax : +81 (06) 6793 0013
URL : <http://www.icom.co.jp/world/index.html>

Icom America Inc.

<Corporate Headquarters>
2380 116th Avenue N.E., Bellevue, WA 98004, U.S.A.
Phone : +1 (425) 454-8155 Fax : +1 (425) 454-1509
URL : <http://www.icomamerica.com>
E-mail : sales@icomamerica.com
<Customer Service>
Phone : +1 (425) 454-7619

Icom Canada

Glenwood Centre #150-6165
Highway 17 Delta, B.C., V4K 5B8, Canada
Phone : +1 (604) 952-4266 Fax : +1 (604) 952-0090
URL : <http://www.icomcanada.com>
E-mail : info@icomcanada.com

Icom (Australia) Pty. Ltd.

Unit 1 / 103 Garden Road, Clayton VIC 3168 Australia
Phone : +61 (03) 9549-7500 Fax : +61 (03) 9549-7505
URL : <http://www.icom.net.au>
E-mail : sales@icom.net.au

Icom New Zealand

146A Harris Road, East Tamaki,
Auckland, New Zealand
Phone : +64 (09) 274 4062 Fax : +64 (09) 274 4708
URL : <http://www.icom.co.nz>
E-mail : inquiries@icom.co.nz

Beijing Icom Ltd.

10C07, Long silver Mansion, No.88, Yong Ding
Road, Haidian District, Beijing, 100039, China
Phone : +86 (010) 5889 5391/5392/5393
Fax : +86 (010) 5889 5395
E-mail : bjicom@bjicom.com
URL : <http://www.bjicom.com>

Icom (Europe) GmbH

Communication Equipment
Auf der Krautweide 24
65812 Bad Soden am Taunus, Germany
Phone : +49 (6196) 76685-0 Fax : +49 (6196) 76685-50
URL : <http://www.icomeurope.com>
E-mail : info@icomeurope.com

Icom Spain S.L

Ctra. Rubi, No. 88 Bajos A 08174, Sant Cugat del Valles, Barcelona, Spain
Phone : +34 (93) 590 26 70 Fax : +34 (93) 589 04 46
URL : <http://www.icomspain.com>
E-mail : icom@icomspain.com

Icom (UK) Ltd.

Blacksole House, Altira Park, Herne Bay, Kent CT6 6GZ, UK
Phone : +44 (01227) 741741 Fax : +44 (01227) 741742
URL : <http://www.icomuk.co.uk>
E-mail : info@icomuk.co.uk

Icom France s.a.s.

Zac de la Plaine
1 Rue Brindejonc des Moulinais BP 5804
31505 Toulouse Cedex, France
Phone : +33 (5) 61 36 03 03 Fax : +33 (5) 61 36 03 00
URL : <http://www.icom-france.com>
E-mail : icom@icom-france.com

Asia Icom Inc.

6F No.68, Sec. 1 Cheng-Teh Road, Taipei, Taiwan, R.O.C.
Phone : +886 (02) 2559 1899 Fax : +886 (02) 2559 1874
URL : <http://www.asia-icom.com>
E-mail : sales@asia-icom.com

Icom Polska

81-850 Sopot, ul. 3 Maja 54, Poland
Phone : +48 (58) 550 7135 Fax : +48 (58) 551 0484
E-mail : icompolska@icompolska.com.pl

Count on us!

Icom Inc.

1-1-32, Kamiminami, Hirano-ku, Osaka 547-0003, Japan

S-14813XZ-C1
© 2012 Icom Inc.