

PTRX-9700 INSTALLATION MANUAL

This document describes installation of the PTRX-9700 Panadapter Module for ICOM IC-9700 radio. PTRX-9700 enables to extend internal RF/IF signals of the IC-9700 as a standart 50 Ohm output on the rear panel. This output can be used to monitor spectrum of the VHF, UHF, 23 cm band signals via connecting it to an SDR. Additionally, reference signal can be injected by using "Reference Injection Board" which is connected to the same 50 ohm SMA port.

This installation is solderless and reversible. The kit is composed by the following items:

1. Panadapter Main Board
2. Reference Injection Board
3. Mechanical Mounting Parts
4. Power Cable
5. U.FL-U.FL Cable Assemblies
6. SMA/SMA Coaxial Cable

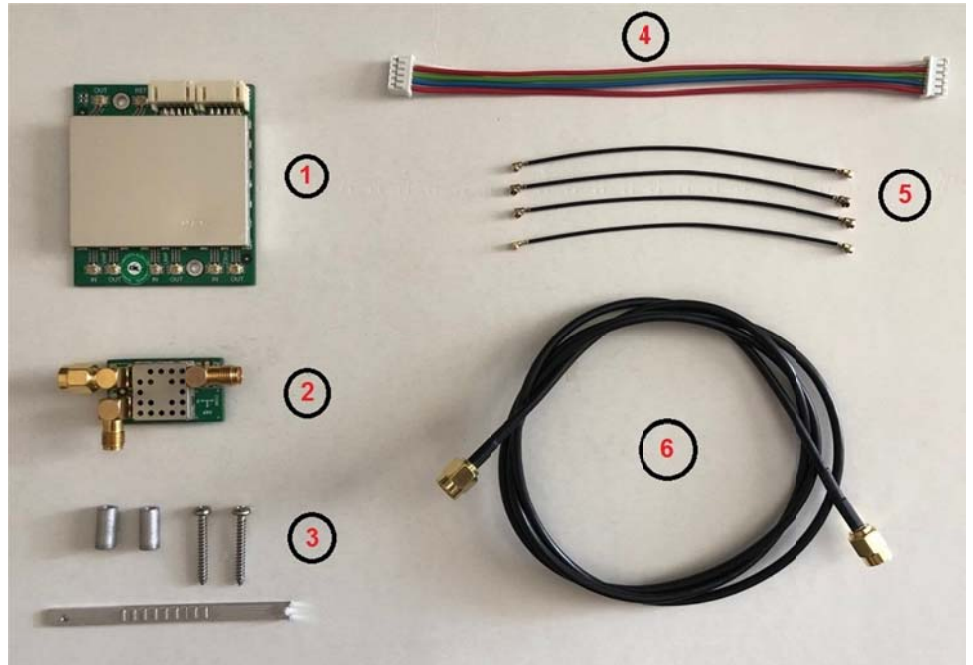

Figure 1

INSTALLATION INSTRUCTIONS

Disclaimer: We are not liable for any damage to your equipment caused by using this extention. Use it at your own risk.

Important Note: Use always the tool provided to plug and unplug U.FL connectors to avoid damaging either radio or panadapter.

1. Turn off the IC-9700 and disconnect all cables connected to the radio.
2. Remove all screws holding the bottom cover. Use the correct screwdriver to avoid stripping screw heads.
3. Remove the two screws shown in **Figure 2**.
4. Use metal spacers and long screws (labeled as 3 in **Figure 1**) to mount panadapter main board.
5. Disconnect U.FL cables of the radio carrying RF/IF signals and connect to U.FL connectors of the panadapter main board in order as shown in **Figure 3**. Use U.FL jumper cable assemblies in **Figure 1** labeled as 5.
6. Disconnect the power cable of the radio (shown in **Figure 4**) and connect to the panadapter first power socket. Connect power cable (in **Figure 1** labeled as 4) between second power socket of the panadapter and power connector of the radio.
7. Disconnect reference input U.FL connector of the radio and connect to the COM port of the panadapter main board.
8. Connect reference U.FL port of the radio to the REF input of the panadapter main board with a U.FL-U.FL cable.
9. In case of injecting reference signal, use Reference injection Board. Injection board ports are shown in **Figure 5**. COM port of the reference injection port is connected to the output SMA connector of the radio using the SMA/SMA cable shown in **Figure 1**.
10. Panadapter ready to use, enjoy your product. Completed instalaltion is shown in the **Figure 6**.

**PRODUCT REGISTRATION: PLEASE REGISTER YOUR PRODUCT TO GET SUPPORT WHEN NEEDED.
EMAIL US P/N CODE ON THE BACK OF THE PCB or COPY of YOUR INVOICE AND YOUR CONTACT DETAILS TO
radioanaloginfo@gmail.com**

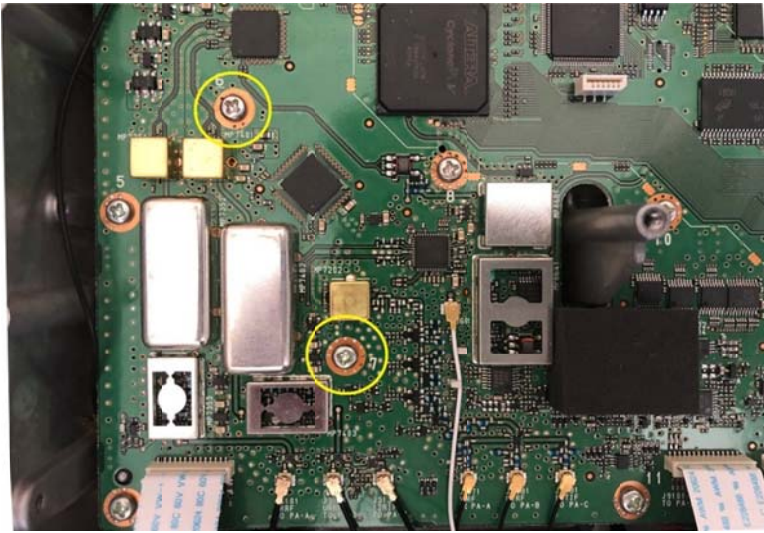

Figure 2

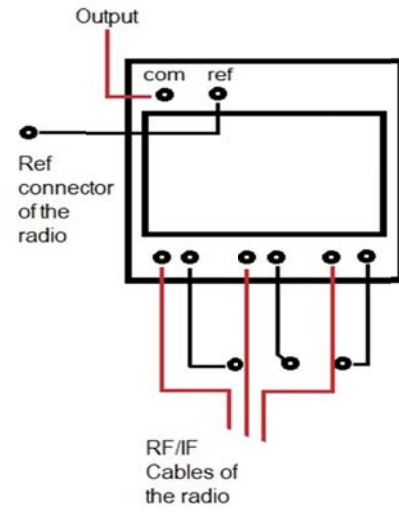

Figure 3



Figure 4

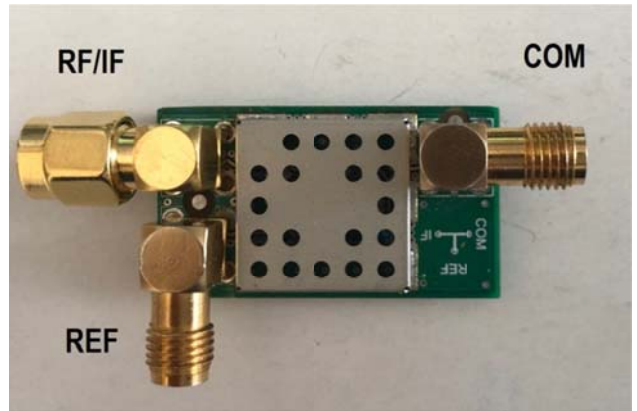

Figure 5



Figure 6