

FURUNO

SERVICE MANUAL

SSB Radio telephone

MODEL FS-1570/2570



FURUNO ELECTRIC CO., LTD.
NISHINOMIYA, JAPAN

© **FURUNO ELECTRIC CO., LTD.**

9-52 Ashihara-cho,
Nishinomiya, Japan

Telephone : 0798-65-2111

Telefax : 0798-65-4200

Your Local Agent/Dealer

All rights reserved.

Printed in Japan

FIRST EDITION : JAN. 2003

A1 : FEB. 14,2003

PUB.No. SME-56360-A1

(NAYO) FS-1570/2570



SME56360A1

Information

Issued by: FURUNO ELECTRIC CO., LTD
 SERVICE MANAGEMENT & COMMANDING DEPARTMENT

No. : FQ5-2003-005 1/2

Date: 2003-02

APPROVED BY

WRITTEN BY

Addenda No.1 to Service Manual for FS-1570/2570, Pub. No. SME-56360

FS-1570/2570 Remedy for Heat Up of TX Coil

T-CPU: Ver.04

Urgency: As soon as possible.

Symptom:

The coil on TX FIL board (05P0736) is damaged by heat. This problem occurs on particular non-maritime mobile service frequencies.

Cause:

The spurious emission causes the low pass filter in bands 3, 4, 5 and 6 to oscillate abnormally and the temperature of the coil raises.

Remedy:

Field modification

Update both T-CPU and C-CPU programs to V.04 at a time.

Program name	Old program number	New program number
T-CPU	05502-05-01.03	05502-05-01.04
C-CPU	05502-06-01.03	05502-06-01.04

Factory modification

In addition to the software change, coils on TX FIL board are changed in type for FS-2570. Now two TX FIL boards exist as below.

Board name	Type	Usage
TX FIL board	05P0736	FS-1570
	05P0736A	FS-1570 and FS-2570

New software also features;

- 1) With NBDP OCCUPIED indication, the volume can be adjusted during NBDP communication. (C-CPU)
- 2) OFF HOOK SPKR "ON/OFF" option is added to RT SETUP menu. (C-CPU)
 ON: The speaker is on when the handset is off hooked. It is on when on hooked.
 OFF: The speaker is always on regardless of the handset status.
- 3) Communication error between T-CPU and C-CPU is indicated by 8-digit error code. (T-CPU)

⑤

SSB

- 4) In NBDP ARQ communication, an error occurs every about 3 minutes. This is solved. (T-CPU)

Table below summarizes the changes.

Band	Frequency range		Coil to be changed (05P0736A)
	Before modification	After modification	
1	1605.0 – 2400.0	1605.0 – 2300.0	
2	2400.1 – 3600.0	2300.1 – 3500.0	
3	3600.1 – 5400.0	3500.1 – 5000.0	L5, 6
4	5400.1 – 8000.0	5000.1 – 7000.0	L7, 8
5	8000.1 – 12000.0	7000.1 – 11000.0	L9
6	12000.1 – 18000.0	11000.1 – 17000.0	L12
7	18000.1 – 27500.0	17000.1 – 27500.0	

Factory-modified set:

a) Software change

FS-1570T: 3535-0324 to 0330, 0336 to 0345, 0356 and after

FS-2570C: 0318, 0341, 0385 to 0390, 0402, 0411, 0437 and after

b) Hardware and software changes

FS-2570T: 3536-0167, 0172, 0179, 0185 and after

Latest program list

C-CPU: 05502-06-01.04

T-CPU: 05502-05-01.04

DSC MODEM: 05502-07-01.02

NBDP MODEM: 05502-08-01.03

Terminal (IB-581): 05502-10-22.03

Terminal (IB-583): 05502-09-22.02

Change to be made on terminal software

IB-581: from Ver.02 to Ver.03

IB-583: from Ver.01 to Ver.02

- 1) Debugging on Macro, Editor and File save function.
- 2) Color selection menu is added. (IB-583)
- 3) Program can be updated with the program floppy disk. (IB-583)

Note) The latest terminal program must be used in the combination of the above list.

Check List	<i>i</i>
-------------------------	-----------------

Chapter 1. General

1.1 General.....	1-1
1.2 Configuration of System.....	1-2
1.2.1 FS-1570 (150W)	1-2
1.2.2 FS-2570 (250W)	1-3
1.3 Connection of NBDP terminal, IB-581	1-4
1.4 Port Specification	1-5
1.5 Handset	1-6
1.6 Communication priority	1-6
1.7 Display of Receiving DSC message	1-7
1.8 Power Status Monitor, PSM-01	1-8
1.9 Using NBDP	1-8

Chapter 2. Location of Parts

2.1 FS-2570C.....	2-1
2.2 FS-2570T	2-5
2.3 FS-1570T	2-9
2.4 Boards in Transceiver Unit	2-13
2.5 Antenna coupler	2-20
2.6 Terminal unit, IB-583	2-24
2.6.1 Boards in Terminal Unit	2-28
2.7 Handset (HS-2001)	2-30

Chapter 3. Set up

3.1 MMSI Number, Model and Group ID3-1

 3.1.1 MMSI Number (MMSI CLEAR).....3-1

 3.1.2 Model (ALL CLEAR).....3-2

 3.1.3 Group ID3-3

3.2 RT SETUP.....3-4

 1. NB (ON/OFF).....3-6

 2. SQ FREQ. (500 Hz-2000 Hz).....3-6

 3. FAX RX ENABLE (ON/OFF)3-6

 4. USER CH (USER CH ENTRY).....3-6

 5. OFFHOOK SPKER (ON/OFF)3-7

 6. REGULATION (INTL): Reserved for future use3-7

 7. TX FREQ. (FREE, MARINE/USER, ITU/USER)3-8

 8. RX FREQ. (FREE, MARINE/USER, ITU/USER)3-8

 9. USER CH (ON/OFF).....3-9

 10. AM ENABLE (ON, TRX, RX)3-9

 11. LSB ENABLE (ON/OFF).....3-9

 12. TX TUNE (ON/OFF)3-9

 13. COUPLER THROU (OFF, RCVD, DIFF).....3-10

 14. TONE.....3-10

 15. TX POWER (FREQ.).....3-10

 16. TX POWER (USER CH)3-10

 3.2.1 USER CH Registration3-11

 3.2.2 Erasing all user channels.....3-12

 3.2.3 Erasing user channel individually3-13

3.3 DSC SETUP3-14

 1. ALARM.....3-16

 2. AUTO ACK3-17

 3. ERASE3-18

 4. MESSAGE3-20

 5. POSITION.....3-23

 6. PRINT OUT3-24

 7. SCAN FREQ.....3-25

 8. VOLUME.....3-25

 9. TEST3-26

 10. SYSTEM.....3-27

3.4 DIP Switch.....3-29

 1. Receiving Position data3-30

 2. Connecting Distress Alert Button.....3-31

 3. Connecting Incoming Indicator3-32

 4. Connecting PC.....3-33

3.5 Jumper	3-34
3.5.1 When FAX-5 is used for W/R	3-34
3.5.2 When TR antenna is used for W/R.....	3-35
3.6 Installing DSP board for NBDP	3-36
3.7 IB-581/IB-583.....	3-37
3.7.1 Manual Reception menu (F3, 6)	3-38
3.7.2 Station menu (F5)	3-38
1. Registering Answerback.....	3-39
2. Registering ID number	3-40
3.7.3 System menu (F6).....	3-41
3.7.4 Printer and language setting.....	3-43

Chapter 4. Updating program

4.1 General.....	4-1
4.2 Connection.....	4-2
4.2.1 C-CPU.....	4-2
4.2.2 T-CPU, DSC MODEM and NBDP MODEM	4-2
4.2.3 IB-583	4-3
4.3 DIP Switch Setting	4-3
4.4 Updating Program.....	4-4
4.4.1 T-CPU and C-CPU	4-4
4.4.2 DSC MODEM and NBDP MODEM	4-7
4.4.3 IB-581	4-9
4.4.4 IB-583	4-11
4.5 Contents of Program File.....	4-13
1. C-CPU (FS-2570C) Program number; 0550206-01.xx.....	4-13
2. T-CPU (FS-1570T/FS-2570T) Program number; 0550205-01.xx.....	4-13
3. DSC MODEM (DSC DSP board) Program number; 0550207-01.xx.....	4-14
4. NBDP MODEM (NBDP DSP board) Program number; 0550208-01.xx...	4-14
5. IB-583 (FS-1570/FS-2570 NBDP terminal) Program number; 0550209-22.xx.....	4-14
6. IB-581 (FS-1570/FS-2570 NBDP terminal) Program number; 0550210-22.xx.....	4-15

Chapter 5. Block Description

5.1 Configuration.....	5-1
5.1.1 Transceiver unit	5-1
5.1.2 Boards in Transceiver unit	5-3
5.1.3 Control unit, FS-2570C.....	5-5
5.1.4 NBDP Terminal unit: IB-581/583 (Option)	5-6
5.1.5 Antenna coupler unit.....	5-8
5.2 Power supply unit	5-9
5.2.1 General.....	5-9
5.2.2 RELAY board (05P0744).....	5-10
5.2.3 SW REG board (05P0737)	5-10
5.3 T-CPU board (05P0732).....	5-11
5.3.1 Function of CPU	5-12
5.3.2 Memory	5-12
5.3.3 Control signals	5-13
5.3.4 Interface circuit	5-19
5.3.5 Digital Signal Processor (DSP).....	5-21
5.4 TX/RX Board (05P0733).....	5-22
5.4.1 Block diagram.....	5-22
5.4.2 Local oscillator.....	5-23
5.4.3 Transmitter/Receiver circuit.....	5-25
5.5 Power Amplifier (PA).....	5-32
5.5.1 FS-1570T PA board (05P0735).....	5-32
5.5.2 FS-2570T DRV board (05P0738)	5-34
5.5.3 FS-2570T PA board (05P0739).....	5-35
5.5.4 FS-2570T COMB board (05P0740).....	5-36
5.5.5 TX FIL board (05P0736)	5-37
5.6 W/R board (05P0734).....	5-39
5.7 C-CPU Board (05P0729)/C-IF Board (05P0730).....	5-42
5.7.1 C-CPU Board (05P0729)	5-43
1. CPU	5-43
2. Memory	5-43
3. LED	5-43
4. NMI SW	5-43
5.7.2 C-IF Board (05P0730)	5-44
5.7.3 Handset	5-45

5.8 Antenna coupler, AT-1560.....	5-46
5.8.1 Antenna tuning.....	5-52
5.9 IB-583.....	5-57
5.9.1 TERM CPU board (16P0209A).....	5-58
5.9.2 PWR Board (16P0211A).....	5-59

Chapter 6. Maintenance

6.1 Self-test.....	6-1
6.1.1 DSC test.....	6-1
6.1.2 RT test.....	6-5
6.2 Self test of Antenna coupler.....	6-10
6.3 Self-test of Terminal Unit.....	6-11
6.4 Tone test.....	6-13
6.5 TEST function in DSC SETUP menu.....	6-15
6.5.1 Unlocking TEST menu.....	6-15
6.6 Messages.....	6-21
6.6.1 Message on control unit.....	6-21
6.6.2 Message on NBDP terminal.....	6-24
6.7 Changing Back-up battery on IB-583: TERM CPU board.....	6-26

Chapter 7. Adjustment and Measurement

7.1 Output power.....	7-1
7.1.1 Power Data.....	7-1
7.1.2 Output power measurement.....	7-3
7.1.3 Adjustment of output power for operating frequency.....	7-4
7.1.4 Adjustment of output power for user channel.....	7-6
7.2 Frequency.....	7-8
7.2.1 Measurement of TX operating frequency.....	7-8
7.2.2 Tone frequency.....	7-10
7.3 PA Bias.....	7-13
7.4 TX Gain.....	7-17
7.5 RX Gain.....	7-18

Appendix 1) DSC Frequency List.....AP1-1

Appendix 2) DSC and NBDP Test Calls.....AP2-1
AP2.1 DSC Test CallAP2-1
AP2.2 NBDP testAP2-3
 AP2.2.1 Receiving MSI (Maritime safety Information)AP2-3
 AP2.2.2 ARQ communicationAP2-5

Appendix 3) Cancelling and receiving distress alert.....AP3-1
AP3.1 Cancelling distress alert.....AP3-1
AP3.2AP3-1

Appendix 4) Specifications.....AP4-1

Appendix 5) Factory acceptance test sheet.....AP5-1

Exploded View.....D-1

Electrical Parts List.....E-1

Contents of Drawings.....S-0

Schematic Diagrams.....S-1

1. Check of installation

The cable must be fixed firmly and tidy.

No.	Item to be checked	Result	Refer to
1.1	Do you understand the system configuration?		Chapter 1
1.2	Mounting and wiring of transceiver, controller and power supply unit - All securing screws are fully tightened. - Units are grounded. - All connections are made correctly. - All connecting wires are secured.		
1.3	MF/HF TX/RX antenna - The lead-in wire is secured without slack. - The antenna does not touch to other objects such as mast, derrick post and rigging. - For safety, "WARNING: High voltage" sign and suitable guards are provided to prevent personnel from coming in accidental contact with dangerous voltage on the lead-in wire. - The lead-in insulator is clean.		
1.4	Antenna coupler AT-1560 - The grounding is connected securely. - The antenna wire is secured. - The shield of the coaxial cable and the control signal cable are fabricated correctly and grounded. - Wires and parts in the matching circuit are not touched each other.		
1.5	RX antenna (FAX-5) - Check for grounding. - Check for waterproofing.		
1.6	NBDP terminal When NBDP terminal is connected, optional NBDP DSP board is installed.		Page 3-36
1.7	W/R2 board for FS-2570 All connections are made on W/R2 board, if provided. When T/R antenna is used, JP1 and JP2 on TX FIL board are changed.		Page 3-34 Page 3-35
1.8	ID, CS, AAB display MMSI, CS, AAIC, AAB and ID are marked on the controller unit, the terminal unit or nearby those units with labels.		
1.9	Power supply unit Check the power supply unit for power specification. Power alteration includes the change of internal wiring and fuse.		

2. Check of settings

No.	Item to be checked	Result	Refer to
2.1	JP-3 on W/R board (power to the antenna unit, Default: OFF)		Page 3-34
2.2	DIP switch setting on T-CPU board for the connection of GNSS, incoming indicator and distress alert button.		Page 3-29
2.3	Check registered MMSI in DSC Setup display.		Page 3-1 Page 3-27
2.4	Model, FS-1570 or FS-2570 is selected through the menu. Power data and contents of RT self test differ between two models.		Page 3-2
2.5	The RT is set through Setup menu. TX FREQ is set in accordance with local regulation.		Page 3-4 Page 3-8
2.6	“SYSTEM” setting of DSC Setup menu is made. WATCH RCVR is set to HF for the ship navigating in the sea area A3.		Page 3-14 Page 3-25
2.7	NBDP terminal is setup through the menu, and AAB and ID are registered. “Slave Delay” of System ([F6]) menu is set to 8 msec.		Page 3-37

MMSI and model registration

1. Press NMI SW (S1) on T-CPU board and enter the password.
2. Select “ALL Clear” and the press [ENT].

JP-3 setting on W/R-1 and 2 boards

	Jumper	Remarks
JP-3	1-2	12 V to FAX-5
	2-3	No power to antenna (Factory setting)

DIP switch setting on T-CPU board

The default setting is screened.

SW	Function		#1	#2	#3	#4
S2	C. Loop		OFF (IEC: Pos.)	OFF (DMC)	OFF (MIF)	OFF (N.C)
	RS-422		ON	ON	ON	
S3	RS-232C		OFF	OFF	ON	ON
	RS-422		ON	ON	OFF	OFF
S4, S5	IC-303-DSC	S4	ON	ON	ON	ON
		S5	OFF	OFF	OFF	OFF
	IC-xxx	S4	OFF	OFF	OFF	OFF
		S5	ON	ON	ON	ON
S6, S7	DMC-5	S6	ON	ON	ON	ON
		S7	OFF	OFF	OFF	OFF
	IC-302-DSC	S6	OFF	OFF	OFF	OFF
		S7	ON	ON	ON	ON

DSC System setup menu

The default setting is screened.

Items to be set			Value			
ALARM	INTERNAL RCVD CALL		ON	OFF		
	AUDIO OLD POSITION		ON	OFF		
	POSITION OLDER		4.0, 3.0, 2.0, 1.0, 0.5H			
	EXT ALARM		DIS/URG	ROUTINE	ALL	OFF
AUTO ACK	COMPLY TYPE		UNABLE	ABLE		
	UNABLE REASON		NO REASON GIVEN			
	POSITION CALL		ON	OFF		
	POLLING CALL		ON	OFF		
POSITION	INPUT TYPE		AUTO	MANUAL		
PRINT OUT	XMIT CALL		AUTO	MANUAL		
	RCVD CALL		AUTO	MANUAL		
	DAILY TEST		AUTO	MANUAL		
SCAN FREQ.	ROUTIINE		F1-F6: OFF			
	DISTRESS		2, 8M: FIXED 4, 6, 12, 16M: ON			
VOLUME	KEY CLICK		ON	OFF		
	HANDSET		32		(0-63)	
	ORDINARY ALARM		35		(0-63)	
	DISTRESS ALARM		38		(38-63)	
SYSTEM (PASSWORD)	MMSI		FIXED			
	LINE OUT		+0.0 DB (-4.5 to +4.5dB in 1.5dB step)			
	WATCH RCVR		MF/HF	MF		
	CH DET S LEVEL		100 (OFF - 255)			
	REGULATION		INTL	RUSSIA		

RT System setup menu

The default setting is screened.

Menu	Setting			
NB	OFF	ON		
SQ FREQ	500Hz to 2000Hz (800Hz)			
FAX RX ENABLE	OFF	ON		
OFFHOOKED SPKER	OFF	ON		
SYSTEM	Password is needed to set following items.			
REGULATION	INTL			
TX FREQ	FREE	MARINE	ITU/USER	USER
RX FREQ	FREE	MARINE	ITU/USER	USER
USER CH	OFF	ON		
AM ENABLE	OFF	TRX	RX	
LSB ENABLE	OFF	ON		
TX TUNE	OFF	ON		
COUPLER THROU	OFF	RCVD	DIFF	

NBDP terminal setup menus, IB-581 and IB-583

The default setting is screened.

Items		Value	Remarks
F3: Operate	6.Manual Reception	AUTO, ARQ, FEC, DIRCT	
F5: Station	5.Answerback Code Entry	MMSI+CS(4digit)+X	Password: ANSWER CODE
	6.Group ID Entry (4/5 digit)		Password: ID CODE
	7.Group ID Entry (9 digit)		
	8.Select ID Entry (4/5 digit)	Sell call number	
	9.Select ID Entry (9 digit)	MMSI	
F6: System	Slave Delay	8msec (0-50msec)	Password: DP6
	TX/RX MSG Save	ON, OFF	
	Edit before sending	ON, OFF	
	Time System	OFF, UTC, SMT, JST	
	Time & Date		
	** Display Mode	Normal, Reverse	Only IB-581 appears
** Window color	Window color setup Default	Only IB-583 appears	
Fn+F1	Language	Normal, Norway, Sweden, UK	Password: DP6
	Printer	PP-510, OTHER	

Note: Enter the password in capital letter.

3. Self test

No.	Test	Procedure	Result	Refer to
3.1	DSC self test	Press [3 TEST] with DSC display.		Page 6-1
3.2	RT self test	Press [3 TEST] with RT display. Items to be checked differ between FS-1570 and FS-2570.		Page 6-5
3.3	Terminal unit self test	[F6], select "self test"		Page 6-11
3.4	Antenna coupler self test	Set S2#2 to ON and press [S3:TUNE] on the COUP board. The self test is not executed when [S1:MANUAL/AUTO] is set to MANUAL.		Page 6-10
3.5	Printer self test	To print out the self test result, turn on the system while holding down [LF]. To print out the DIP switch setting, turn on the system while holding down [NLQ].		

4. Check of program version

Use the system with the latest program.

No.	How to read program number	Refer to
4.1	Press [3 TEST] with DSC display for DSC self test. To check the detail program version, press [1 RT] five times while holding down [File] with the test result display.	Page 6-1 Page 6-2
4.2	Press [F6] and select "self test" for terminal unit self test. To check the detail program version, press [F1] while holding down [Alt] and [Fn] with the test result display.	Page 6-11
4.3	U1 in antenna coupler unit	Page 2-22

Test result

Program		Program Version
Transceiver unit	MAIN (T-CPU)	
	DSC modem	
	NBDP modem	
Controller unit	No.1 FS-2570C: PANEL-1 (C-CPU)	
	No.2 FS-2570C: PANEL-2 (C-CPU)	
NBDP terminal	IB-581 Terminal unit	
	IB-583 Terminal unit	
AT-1570	U1	

5. Functional check

No.	Item to be checked	Result	Refer to
5.1	Position from GNSS is displayed in DSC display. "POSITION" in DSC Setup menu is set to "AUTO". Receivable sentences are GGA, GLL, RMC and ZDA.		Page 3-30 Page 3-23
5.2	TUNE OK appears in all bands. [S1:MANUAL/AUTO] in AT-1560 is set to "AUTO" for automatic tuning.		Page 6-22
5.3	Use the check list on the next page for rated output power.		Chapter 7
5.4	When the transmitting VC voltage drops more than 10%, change the power cable to one longer diameter, if possible.		
5.5	The receiver sensitivity is checked by receiving a signal from an appropriate station or sky noise.		
5.6	Using [6 SCAN], the system scans registered Routine frequencies. Scan frequencies are entered through "SCAN"/DSC setup menu. Routine frequencies are international frequencies if not specified.		Page 3-25 Page 3-27 AP-1
5.7	DSC message is printed out by pressing [6 Print].		
5.8	NBDP terminal - The message is written and read to/from the floppy disk by using "Open" and "Close" in [F1] menu. - The file is printed out by using "File to Print" in [F1] menu.		
5.9	BK circuit works normally.		

Transmitter check list

Frequency	T/R Output (W)	Meter indication			Power data	TUNE OK/NG	Freq. Error (within ± 10 Hz)
		IC	VC	IA			
2M	J3E:						
	J2B:						
3M	J3E:						
	J2B:						
4M	J3E:						
	J2B:						
6M	J3E:						
	J2B:						
8M	J3E:						
	J2B:						
12M	J3E:						
	J2B:						
16M	J3E:						
	J2B:						
18M	J3E:						
	J2B:						
22M	J3E:						
	J2B:						
25M	J3E:						
	J2B:						

6. Communication test

See Appendix 2.

Type	Result	Called station	Frequency	Time
Telephone				
DSC TEST CALL				
NBDP				

7. Noise and interference check list

Following checks are made in all bands to make sure that no interference to and from the radiotelephone is observed.

During transmission (voice and TLX), check that;	Result
The distress alert and the incoming indicator are not interfered. *LED brightness does not change and the buzzer sounds without noise. *The unit is not activated.	
The brightness of emergency and ordinary lights is not changed.	
The head of printer does not move.	
The Inmarsat B is not interfered. *The antenna does not move. *No change is observed in the status display. *No noise is heard from TELs, Handset and FAX.	
No noise is heard from on VHF.	
No change is observed in the radar display.	
No noise is heard from public addressor.	
No interference to speed log, depth sounder, steering gear, navigational aids and etc. *Check for normal indication and functions.	
No interference to the display and the indicator in the navigational panel and etc. * Check for normal indication and functions.	
The TX signal is not heard from own handset speaker of the radiotelephone.	
During reception, check that;	Result
No noise is heard from the radiotelephone during the charge of the battery.	
No noise is heard from the radiotelephone during the reception of NMEA data.	
During VHF transmission, no noise is heard from the radiotelephone.	
During radar transmission, no noise is heard from the radiotelephone.	

Interference from FS-1570/2570

	Band									
	2M	3M	4M	6M	8M	12M	16M	18M	22M	25M
Inmarsat B										
Inmarsat C										
No.1 VHF										
No.2 VHF										
AIS										
No.1 radar										
No.2 radar										
No.1 GPS										
No.2 GPS										
FAX										
NAVTEX										
Amplifier										
Sounder										
VDR										
Gyro										
Steering panel										

Chapter 1. General

1.1 General

FS-1570 (150W) and FS-2570 (250W) are a MF/HF radiotelephone with built-in DSC, DSC watch receiver and NBDP.

- 1) Two controllers, FS-2570Cx2 can be connected to the transceiver unit: [CONTROLLER-1] (high priority) and [CONTROLLER-2] ports. The system is turned on and off only by the controller 1. The power switch on the controller 2 is used to turn on and off the controller 2.
- 2) The printer for DSC and NBDP terminal (IB-583) is connected to the controller 1.
- 3) The DSC general frequencies watch receiver board is installed optionally into FS-2570, but not into FS-1570. If the DSC general frequencies watch receiver board is not used, the radiotelephone receives the DSC signal.
- 4) Use either "HANDSET" port. Do not use both handset ports at the same time. The handset should be specified one.

Table1.1.1 Configuration

Unit	FS-1570	FS-2570	Remarks
Transceiver unit	FS-1570T (150Wpep)	FS-2570T(250Wpep)	
Control unit (controller)	FS-2570C		A maximum of two units
Antenna coupler	AT-1560-15	AT-1560-25	
Power supply unit	PR-300	PR-850A	
DSC general frequencies watch receiver board	-	Option	
Pre-amplifier for DSC W/R receiver	FAX-5 (Whip ANT:2.6 m)		Option
NBDP terminal	IB-581 or IB-583		Option
NBDP modem board (DSP)	05P0751		Option
DMC unit	DMC-5		Option
Distress alarm button	IC-302-DSC		(Selecting either one)
Incoming indicator	IC-303-DSC		Option
External loudspeaker	SEM-21Q		Option
Handset	HS-2001		
	HSC-701K-20B		Option
Printer	PP-510		Option
Printer I/F	IF-8500		Option
Power Status Monitor	PSM-01		Option
BK controller	BK-300		Option

* DSC distress and safety frequencies watch receiver board is standard built-in.

1.2 Configuration of System

1.2.1 FS-1570 (150W)

Fig.1.2.1 shows the configuration of FS-1570.

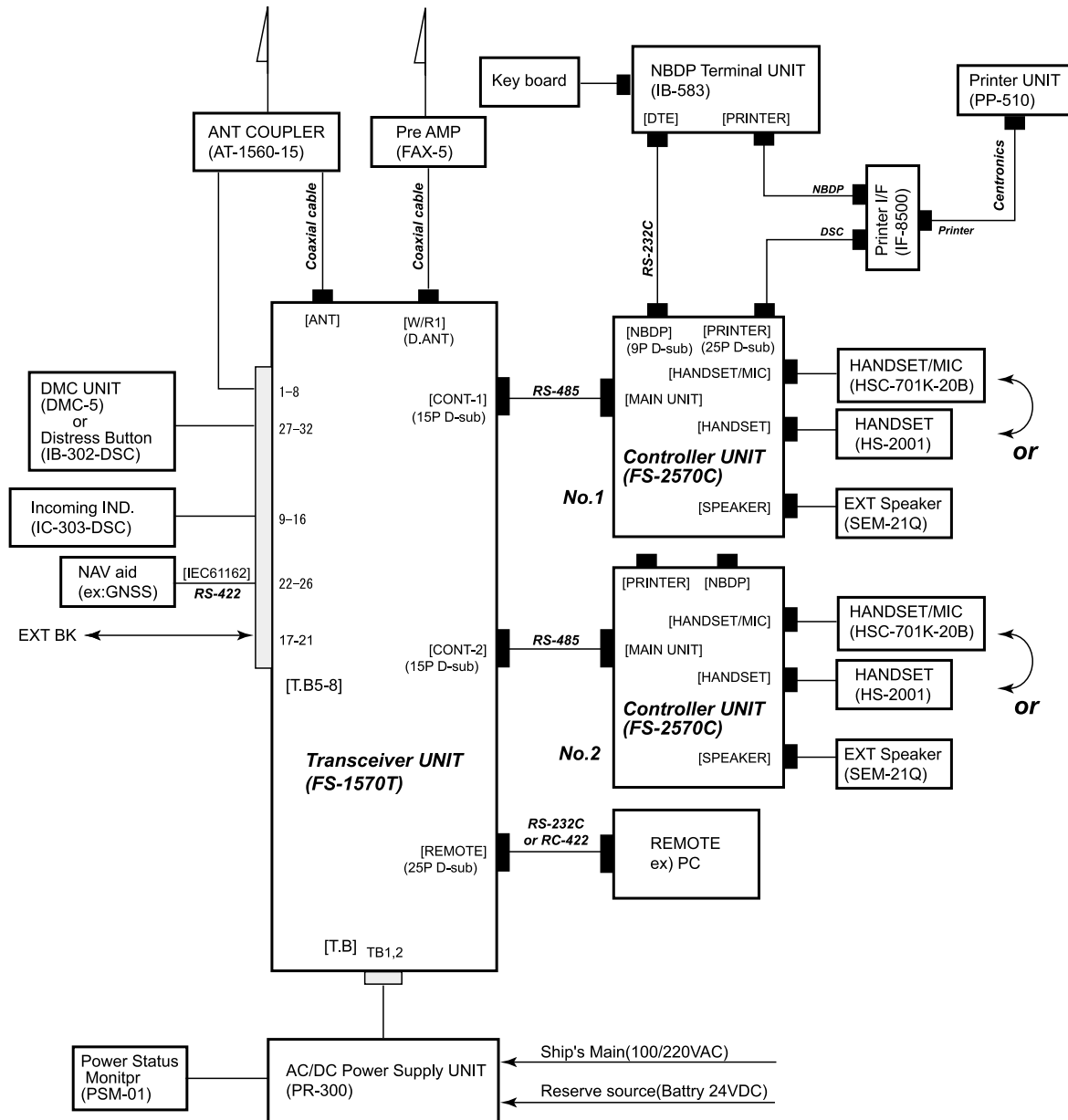

Fig.1.2.1 Configuration of FS-1570

1.2.2 FS-2570 (250W)

Fig.1.2.2 shows the configuration of FS-2570.

Note) DSC general frequencies watch receiver antenna;

- 1) Install a DSC watch receiver antenna (FAX-5+2.6 m Whip), or
- 2) Use MF/HF antenna. When the antenna is used commonly, SSB and NBDP cannot be used during the scanning of DSC general frequencies.

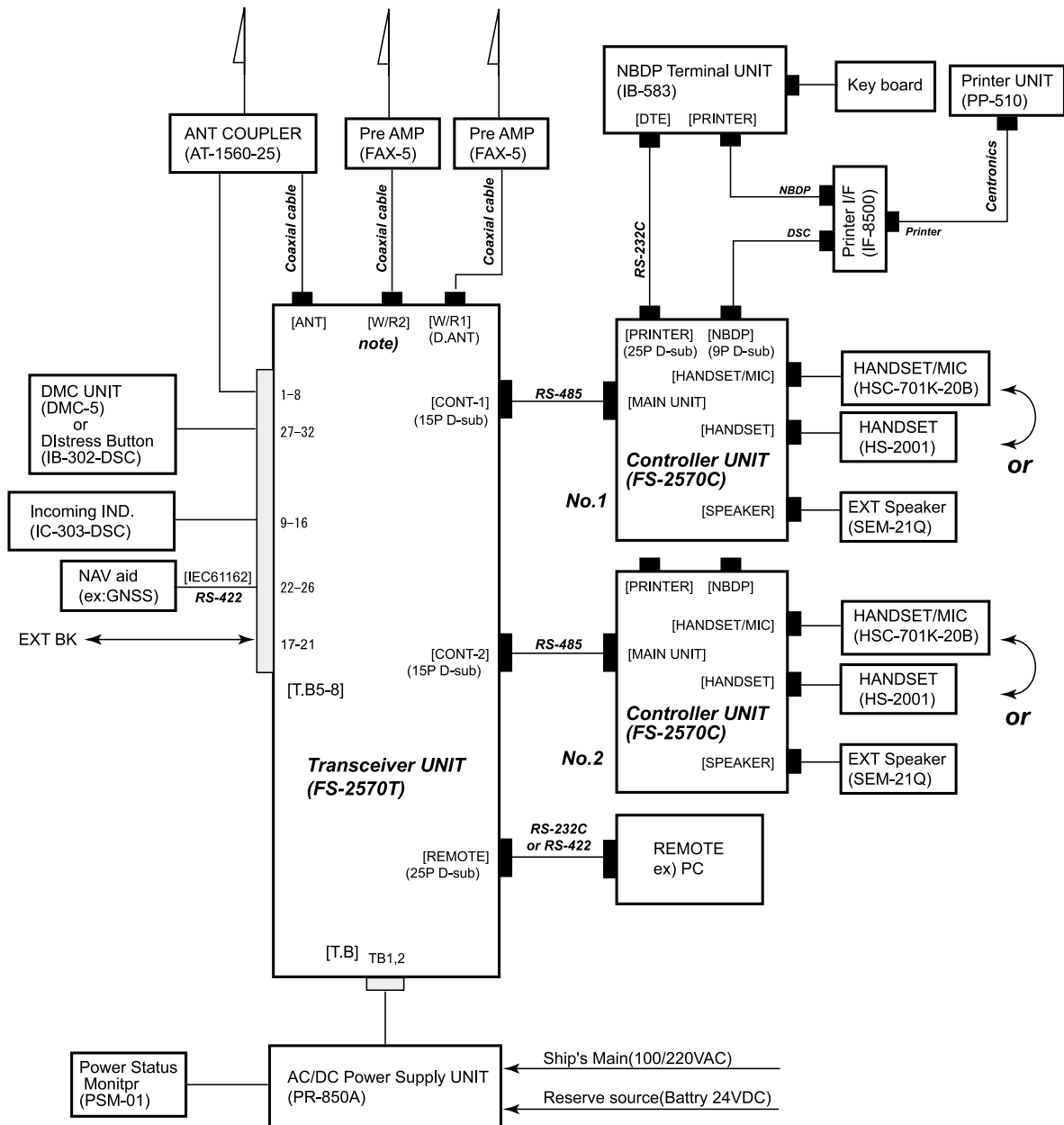

Fig.1.2.2 Configuration of FS-2570

1.3 Connection of NBDP terminal, IB-581

The NBDP terminal IB-581 can be connected to the system by using IF-8500, instead of IB-583 as below. **IB-581 and IB-583 use a different NBDP terminal program. IB-581 for FS-1570/2570 differs from one for DP-6 terminal program .**

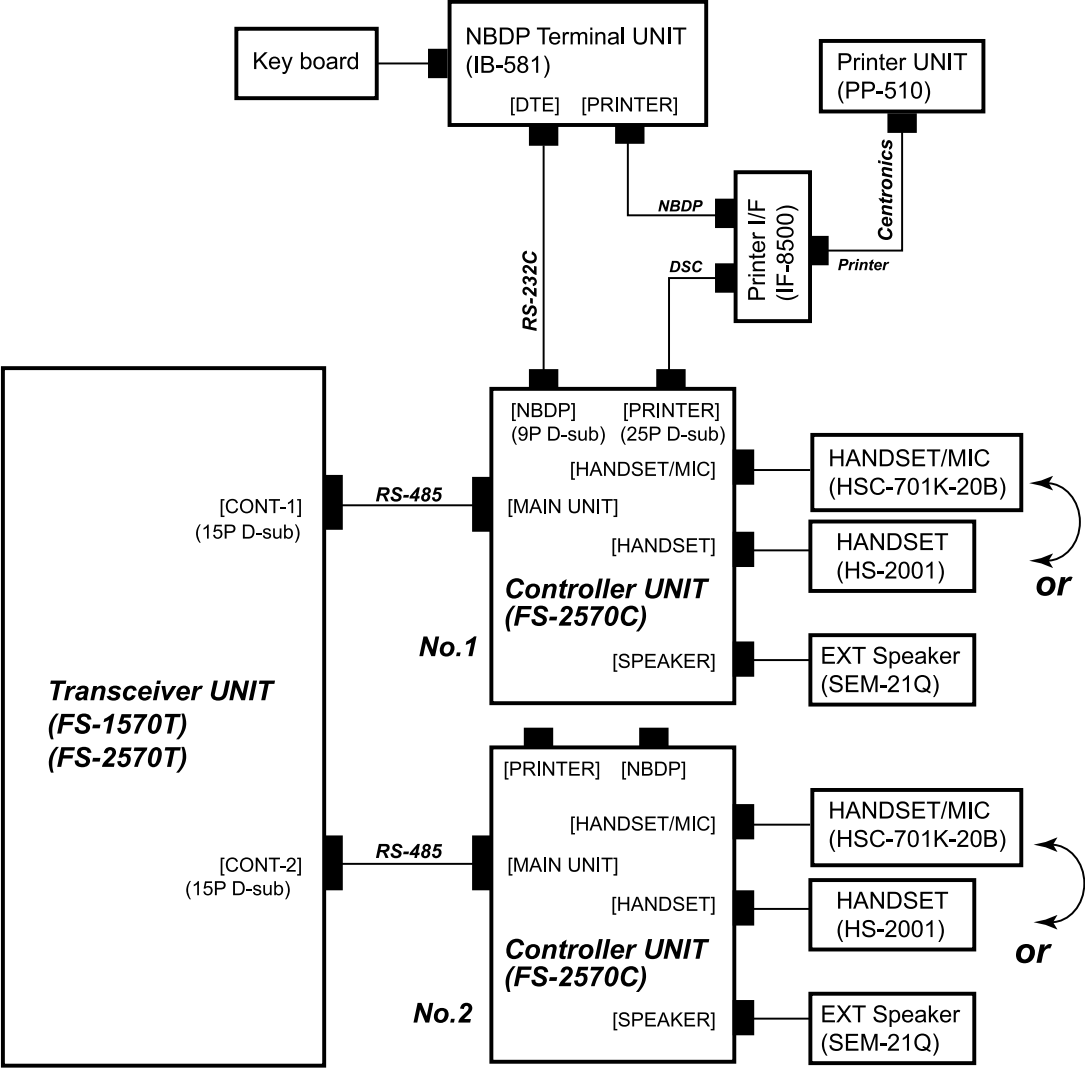

Fig.1.3.1 Connection of IB-581

1.4 Port Specification

Table 1.2.1 lists the signal type of each port.

Table 1.4.1 Port specification

Unit	Port name		Signal	Remarks
FS-1570T FS-2570T	CONTROLLER-1		RS-485	The cable is up to 50 m long. Only controller 1 turns on/off the system.
	CONTROLLER-2		RS-485	
	REMOTE		RS-232C/422	DIP SW selectable: S2-#3/ S3-#1, -#2/-#3,-#4 on T-CPU board
	T/R ANT		50 Ω	
	W/R1 (D.ANT)		50 Ω	Set J3 on W/R board to power the antenna when FAX-5 is connected.
	W/R 2(FS-2570T only)		50 Ω	
	TB-6	COUPLER	C.Loop	The cable is up to 50 m long.
		RCV BZ	C.Loop	DIP SW selectable: S4 and S5 on T-CPU board
	TB-7	EXT BK		BK (+), TX KEY, RX MUTE
		IEC61162-1	RS-422/C.Loop	DIP SW selectable: S2-#1 on T-CPU board (NMEA Ver.2.0 GGA>RMC>GLL, ZDA)
TB-8	DMC or Distress Button	RS-422/C.Loop	DIP SW selectable: S6 and S7 on T-CPU board	
TB-1, 2	24VDC	FS-1570: 20 A FS-2570: 35 A		
FS-2570C	MAIN UNIT		RS-485	
	NBDP		RS-232C	SD, RD
	PRINTER*		Centronics	For DSC and NBDP
	HANDSET		MIC)600Ω, -10dBm SP)150Ω, 2.5mW	Type: HS-2001 DSC AUTO ACK controlled by HOOK signal
	HANDSET/MIC		MIC)600Ω, -10dBm SP)200Ω, 2.5mW	Type: HSC-701K-20B DSC AUTO ACK controlled by HOOK signal
	SPEAKER		4 Ω/4 W	External SP has high priority.
AT-1560	TB1	RF	50 Ω	The cable is up to 50 m long. TUNE POWER: 15 W
	TB2	GND		
	TB3	CONT	C.Loop	The cable is up to 50 m long.
IB-583	DTE		RS-232C	SD, RD
	PRINTER		Centronics	
	Key board		IBM PS/2	

* Connect the printer for DSC/NBDP terminal (IB-583) to FS-2570C which is connected to [CONTROLLER-1] port.

1.5 Handset

Either HANSET (HS2001) port or HANDSET/MIC (HSC-701K-20B) port is used. Do not use them at the same time. HOOK and PTT lines of these ports are connected in parallel.

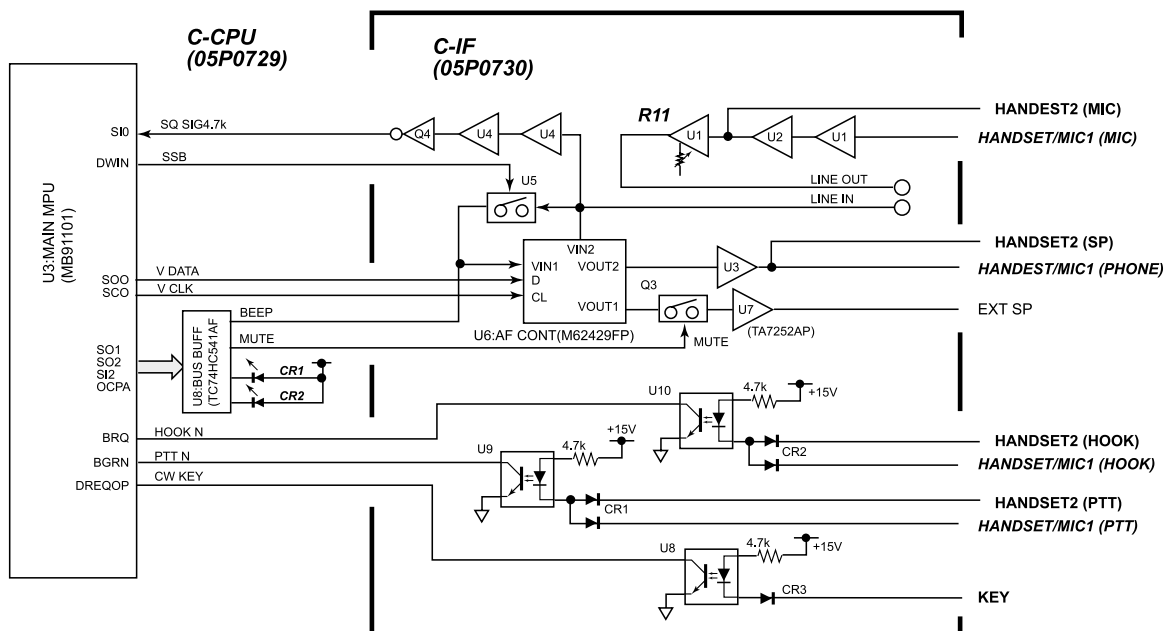

Fig.1.5.1 Block diagram of C-IF

HOOK signal:

- AUTO ACK of DSC does not work when the handset is off-hooked.
- When the handset is off-hooked, "Occupied Another Controller" appears on the display of another FS-2570C. No.1 controller works even when the handset is off-hooked on No.2 controller.

1.6 Communication priority

DSC distress alert has the highest priority. No priority is placed on other functions.

1.7 Display of Receiving DSC message

The received DSC message is displayed depending on the priority. In the distress alert message display, the safety message received is not displayed, but printed out. When the messages in the same category are received, the latest message is displayed and printed.

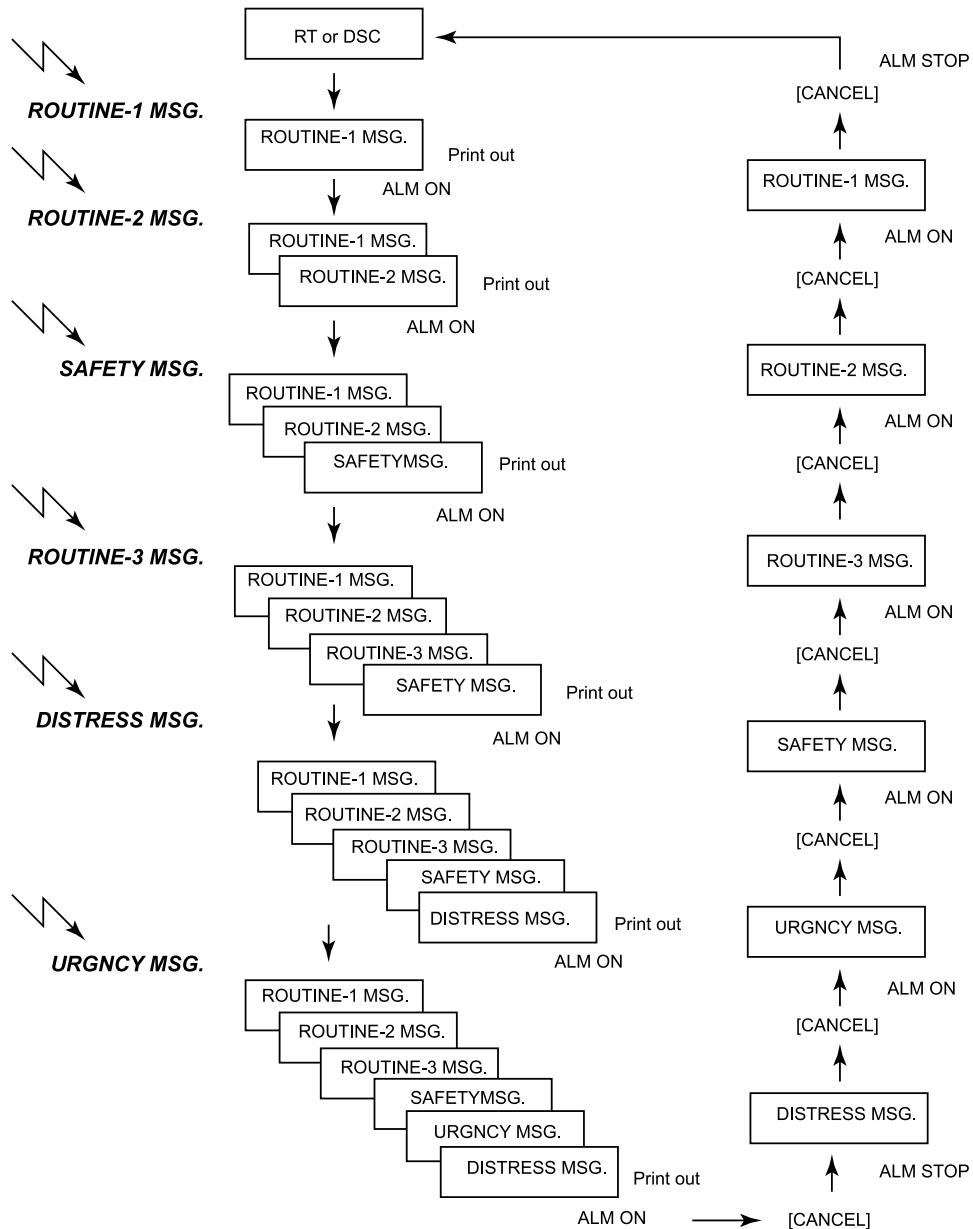

Fig.1.7.1 Display of DSC Message

1.8 Power Status Monitor, PSM-01

The power status monitor, PSM-01 is optionally available. The unit generates aural and visual alarms when the ship's supply is switched from the ship's mains to the reserve source. The unit is installed at the place where the ship is normally navigated.

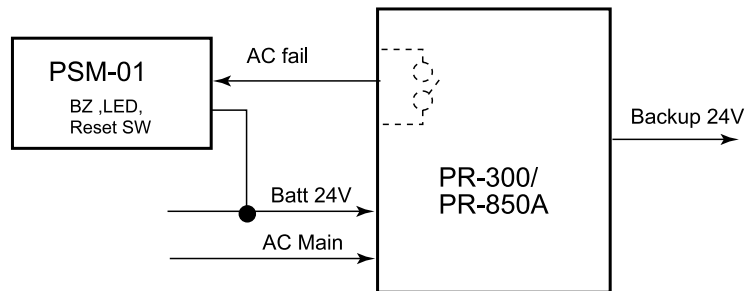

Fig.1.8.1 Connection of PMS-01

1.9 Using NBDP

When using the NBDP, taking into account the followings.

- 1) NBDP frequency is set on the NBDP terminal but not on the RT.
- 2) The NBDP can be used only when "Occupied NBDP" appears on the RT display.

IB-583 brightness adjustment

Press [F6] while holding [Alt] to decrease the brightness by 8 levels. To increase the brightness, press [F7] while holding [Alt].

Chapter 2. Location of Parts

2.1 FS-2570C

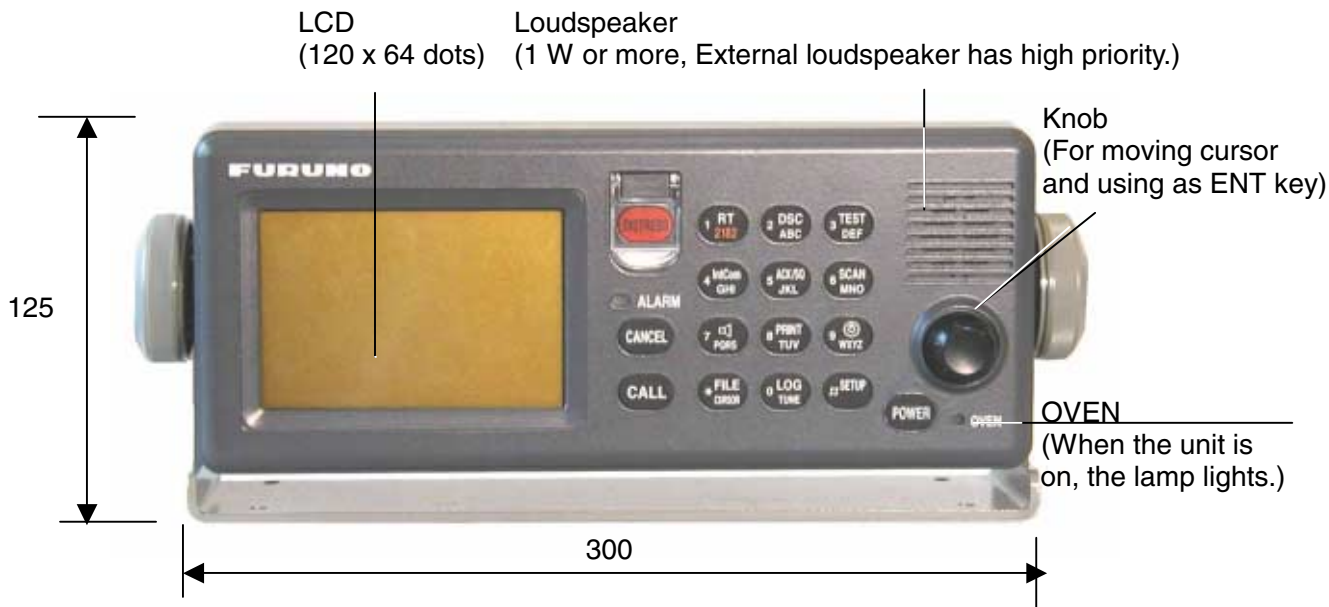

Fig.2.1.1 Display unit, front view

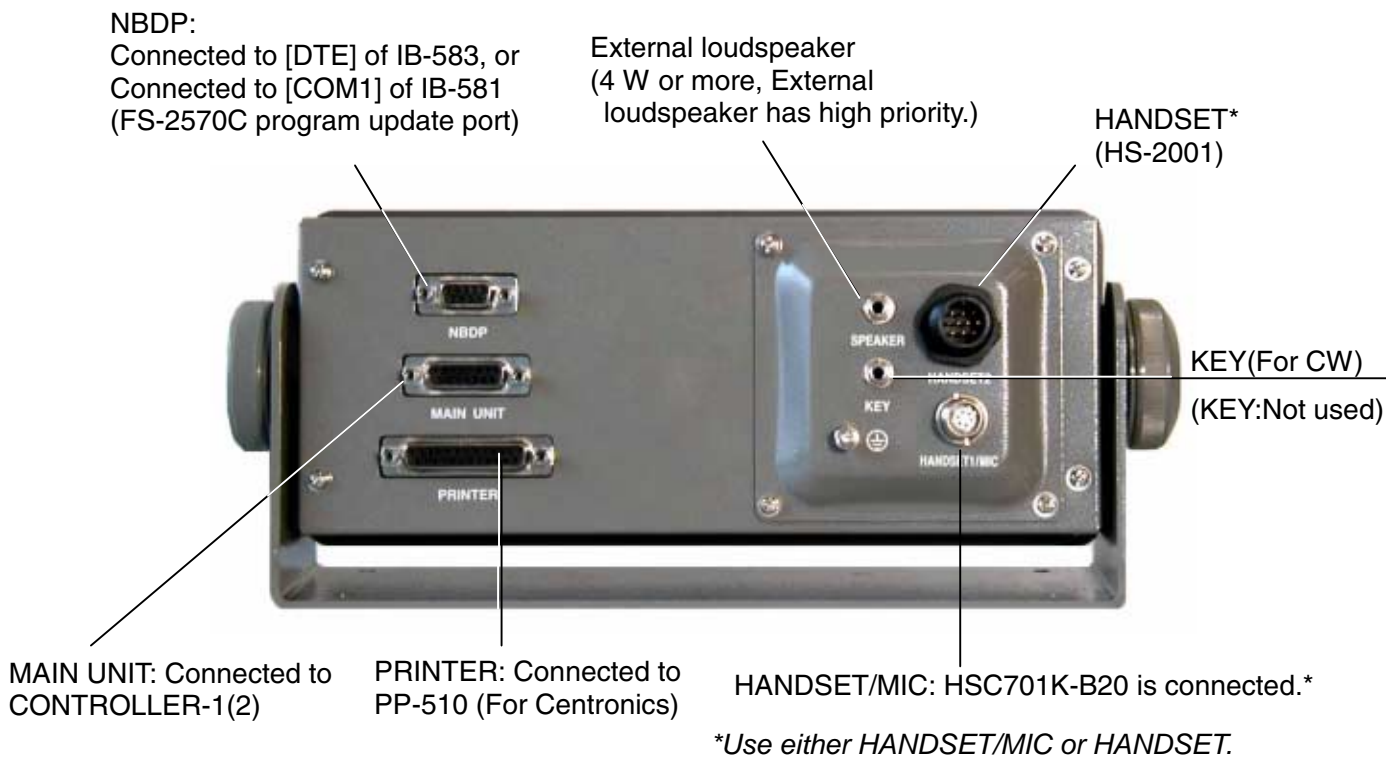

Fig.2.1.2 Display unit, rear view



Fig.2.1.3 Display unit cover

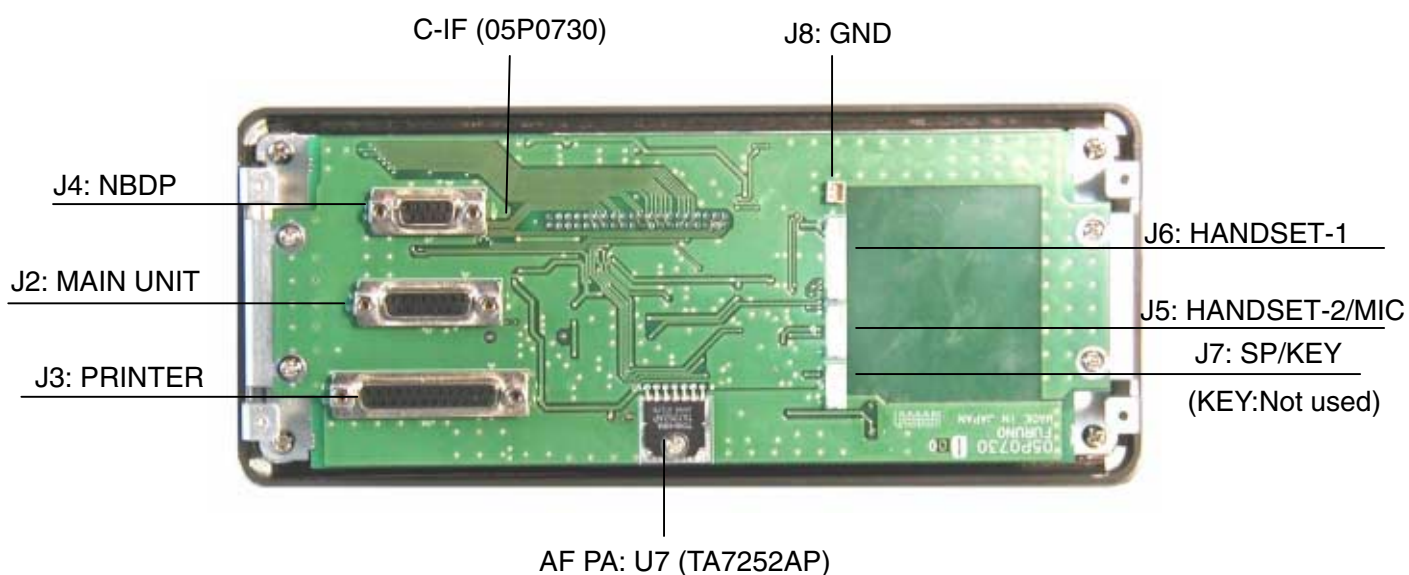

Fig.2.1.4 C-IF (05P0730) board, side A
- Display unit with cover removed

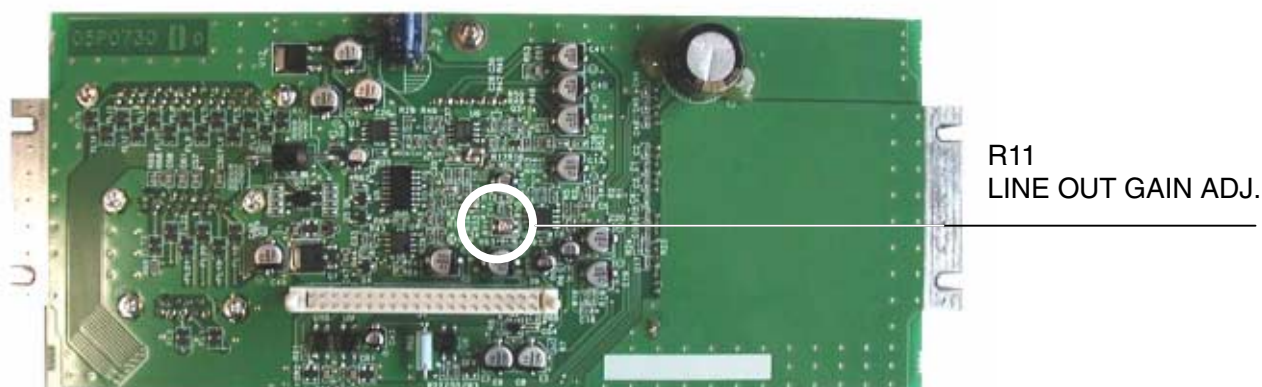

Fig.2.1.5 C-IF (05P0730) board, side B

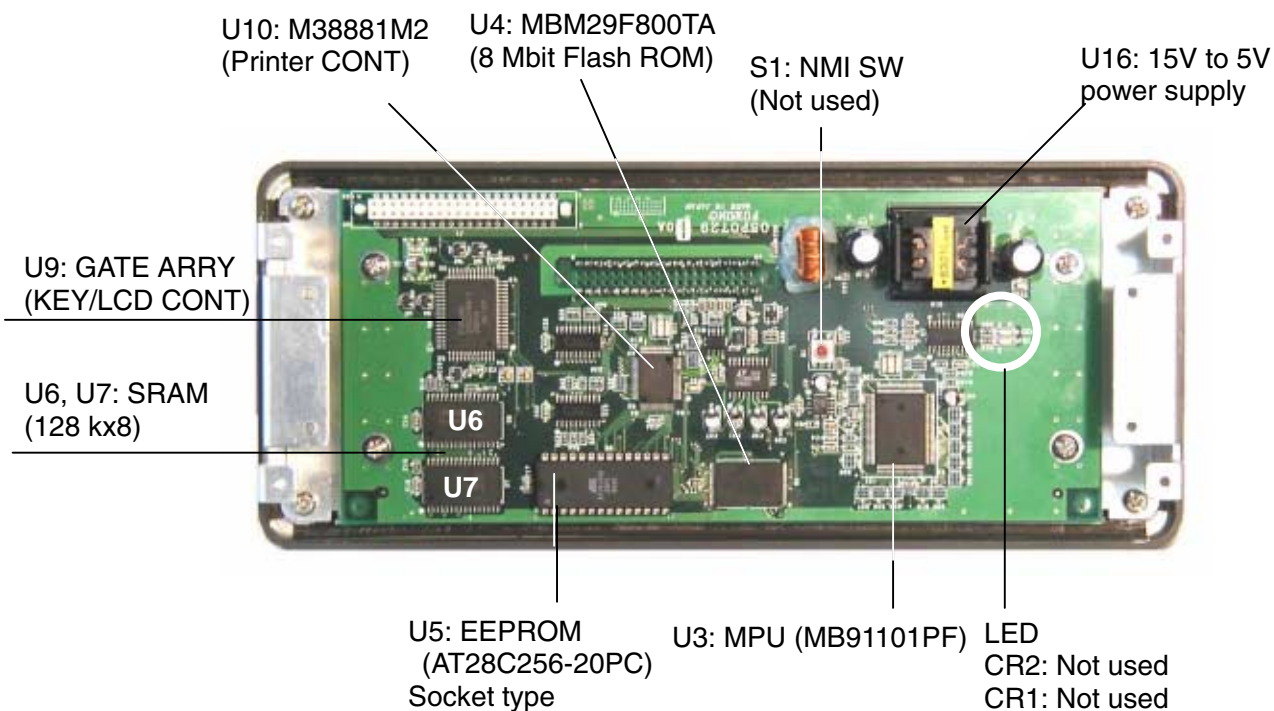

Fig.2.1.6 C-CPU (05P0729) board, side A
- Display unit with C-IF board removed

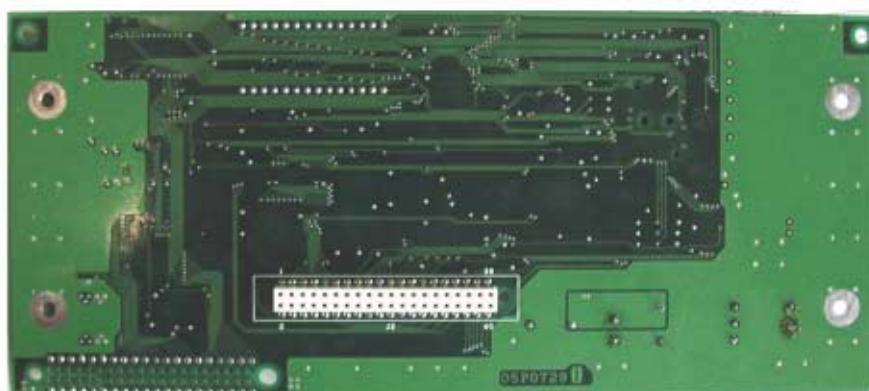

Fig.2.1.7 C-CPU (05P0729) board, side B



Fig.2.1.8 Display unit with C-CPU (05P0729) board removed



Fig.2.1.9 PANEL board (05P0728), side - Display unit with shield cover removed

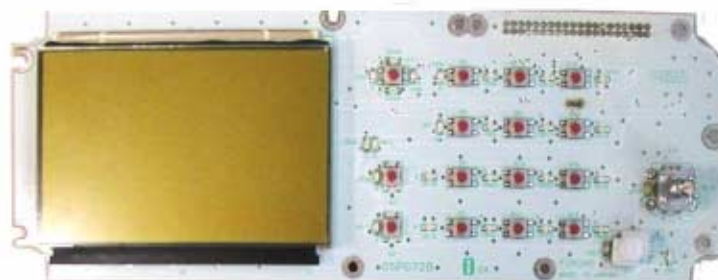

Loudspeaker
(8 Ω /0.5 W)



Fig.2.1.10 PANEL (05P0728) board side A (above) and Panel with loudspeaker (below)

2.2 FS-2570T

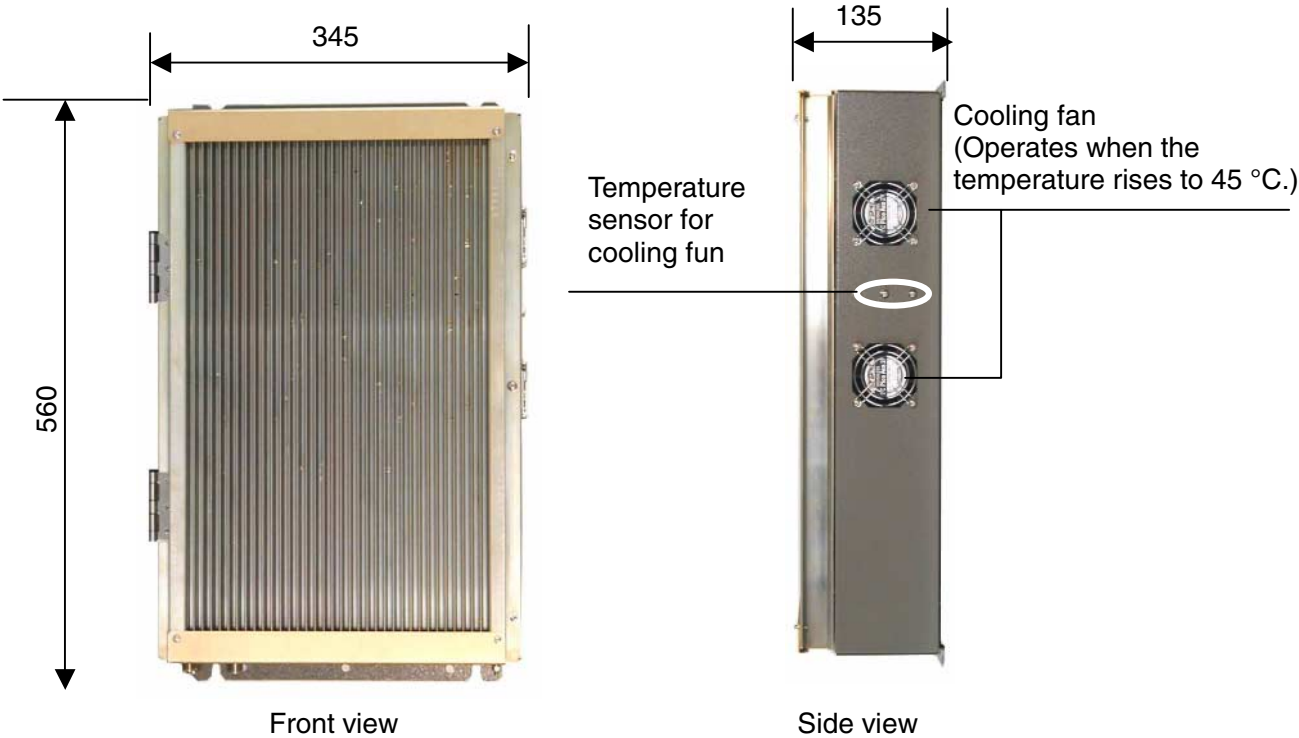

Fig.2.2.1 Transceiver unit

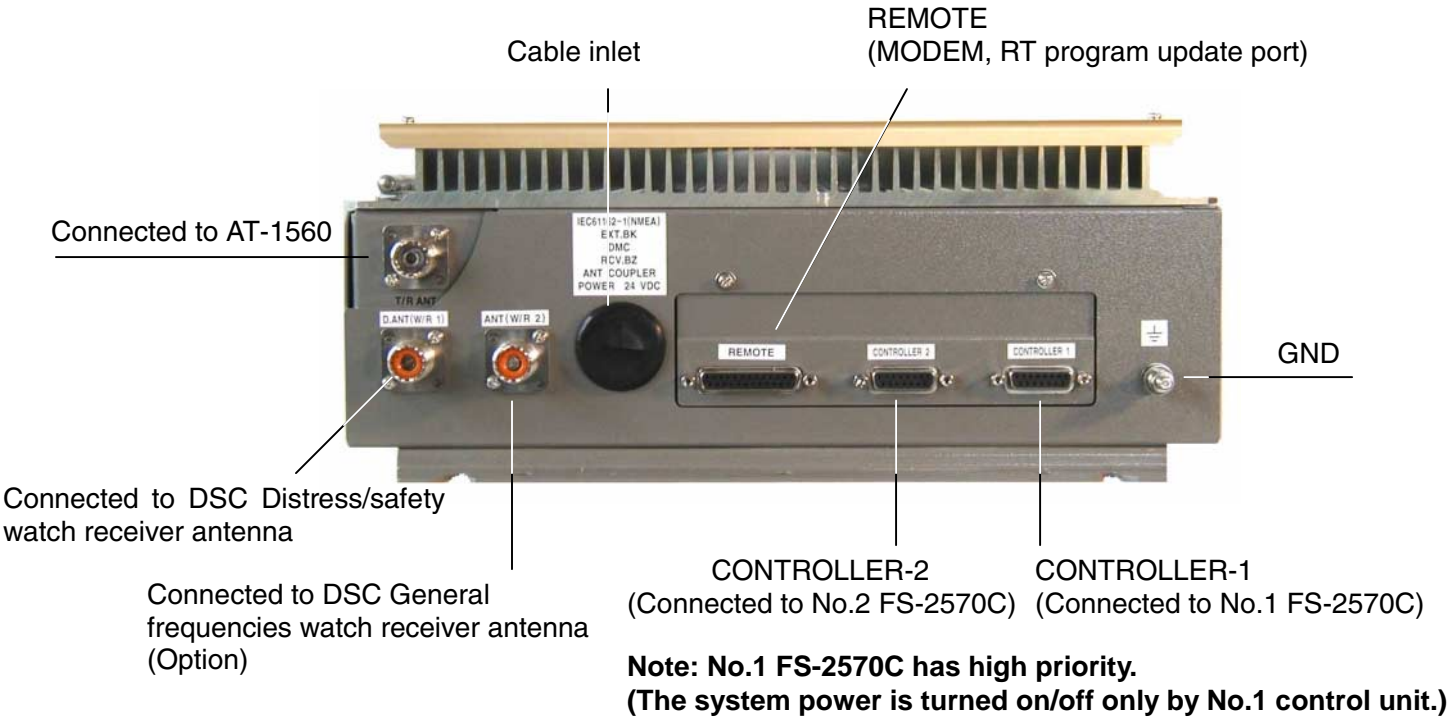

Fig.2.2.2 Transceiver unit, bottom view



Fig.2.2.3 Transceiver unit with door opened

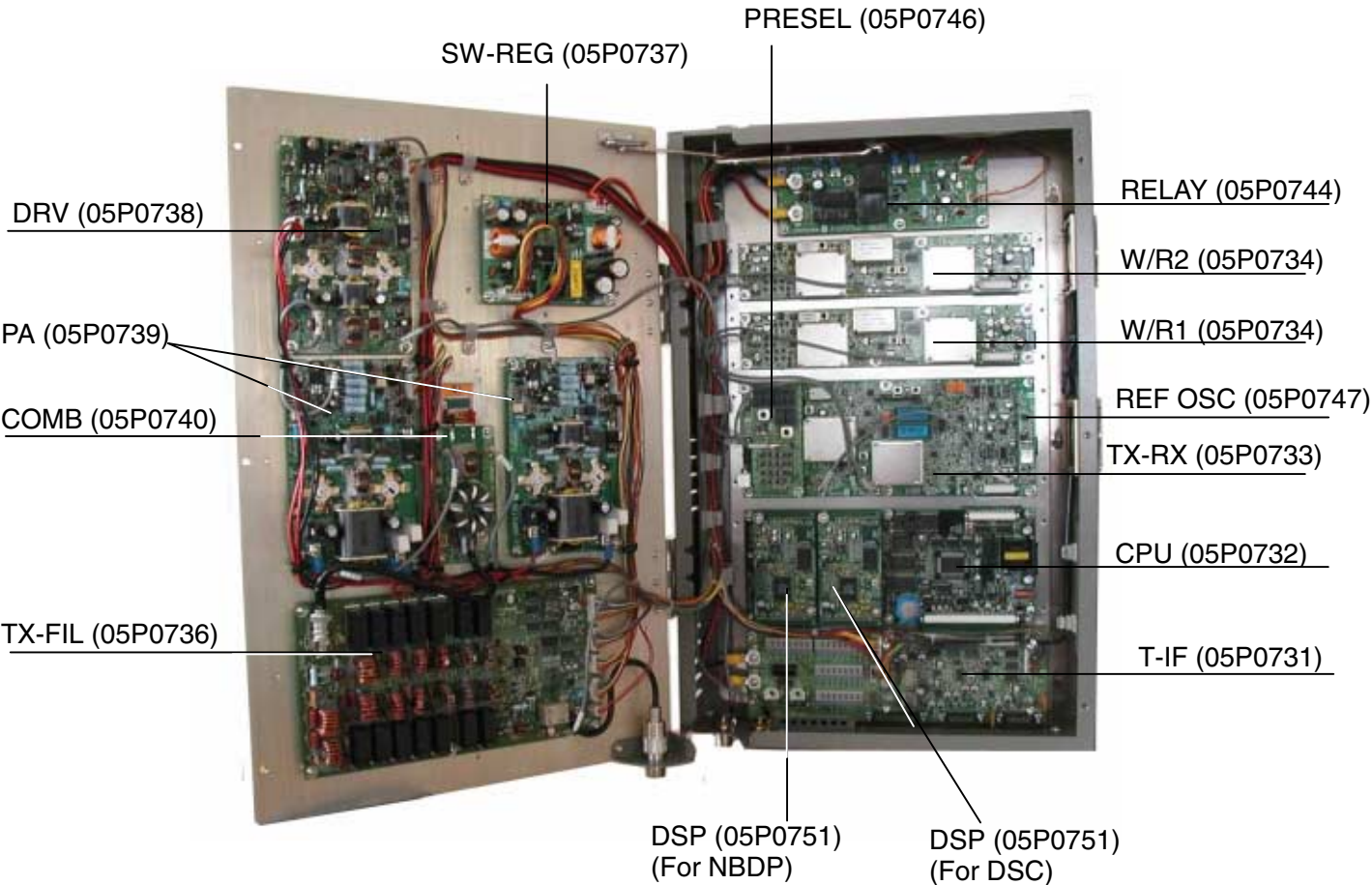

Fig.2.2.4 Transceiver unit with shield covers removed

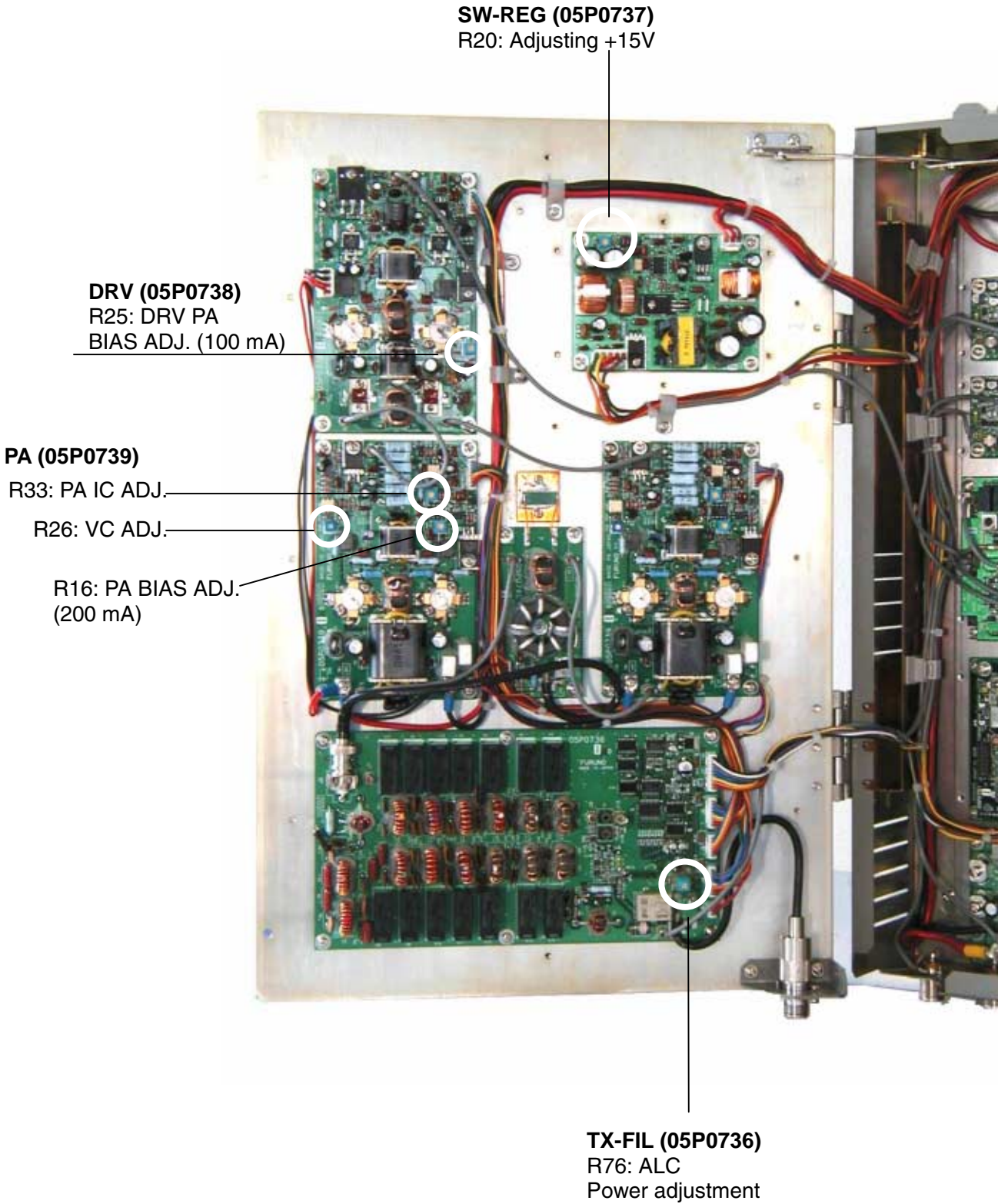

Fig.2.2.5 Back side of the transceiver door

W/R (05P0734)

J3: When FAX-5 antenna is connected, select ACTIV side. (Short circuit between 1 and 2.)

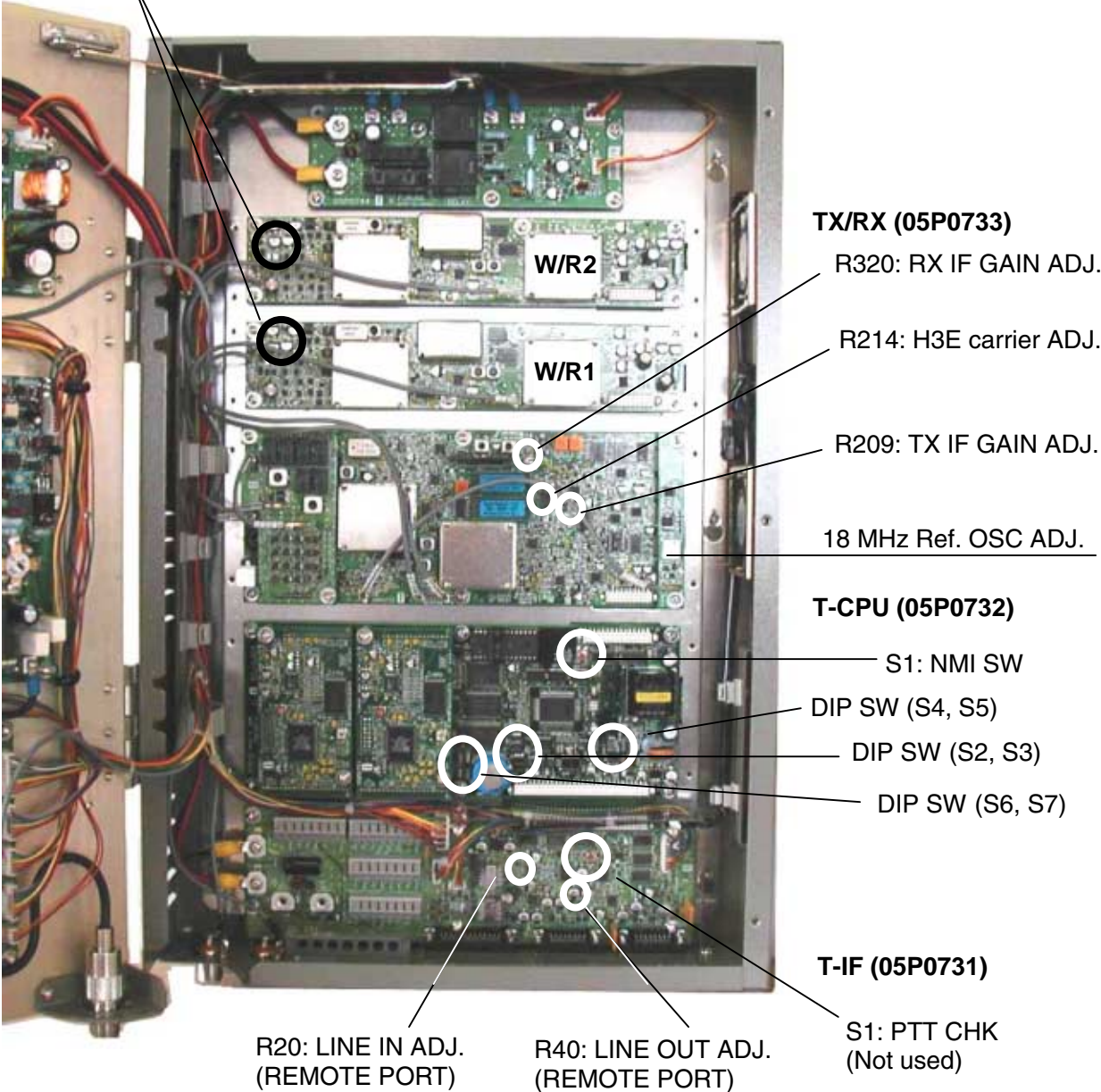

Fig.2.2.6 Inside of Transceiver unit

2.3 FS-1570T

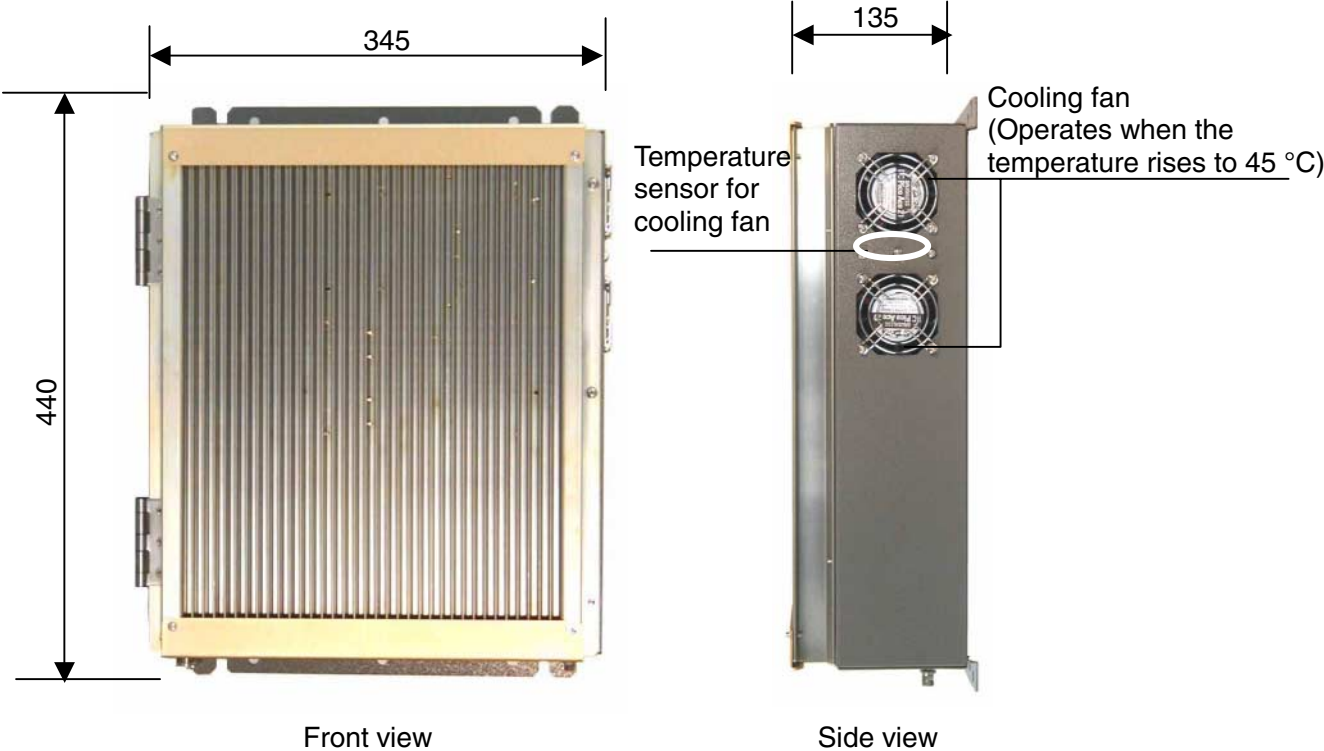
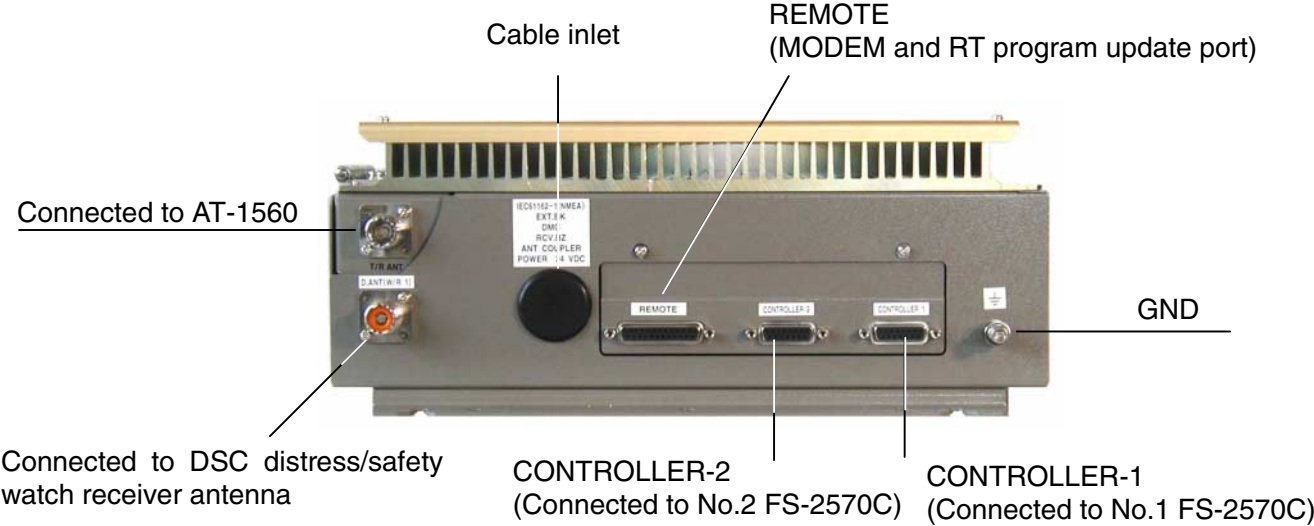

Fig.2.3.1 Transceiver unit



**Note: No.1 FS-2570C has high priority.
(The system power is turned ON/OFF only by No.1 control unit.)**

Fig.2.3.2 Transceiver unit, bottom view



Fig.2.3.3 Transceiver unit with door opened

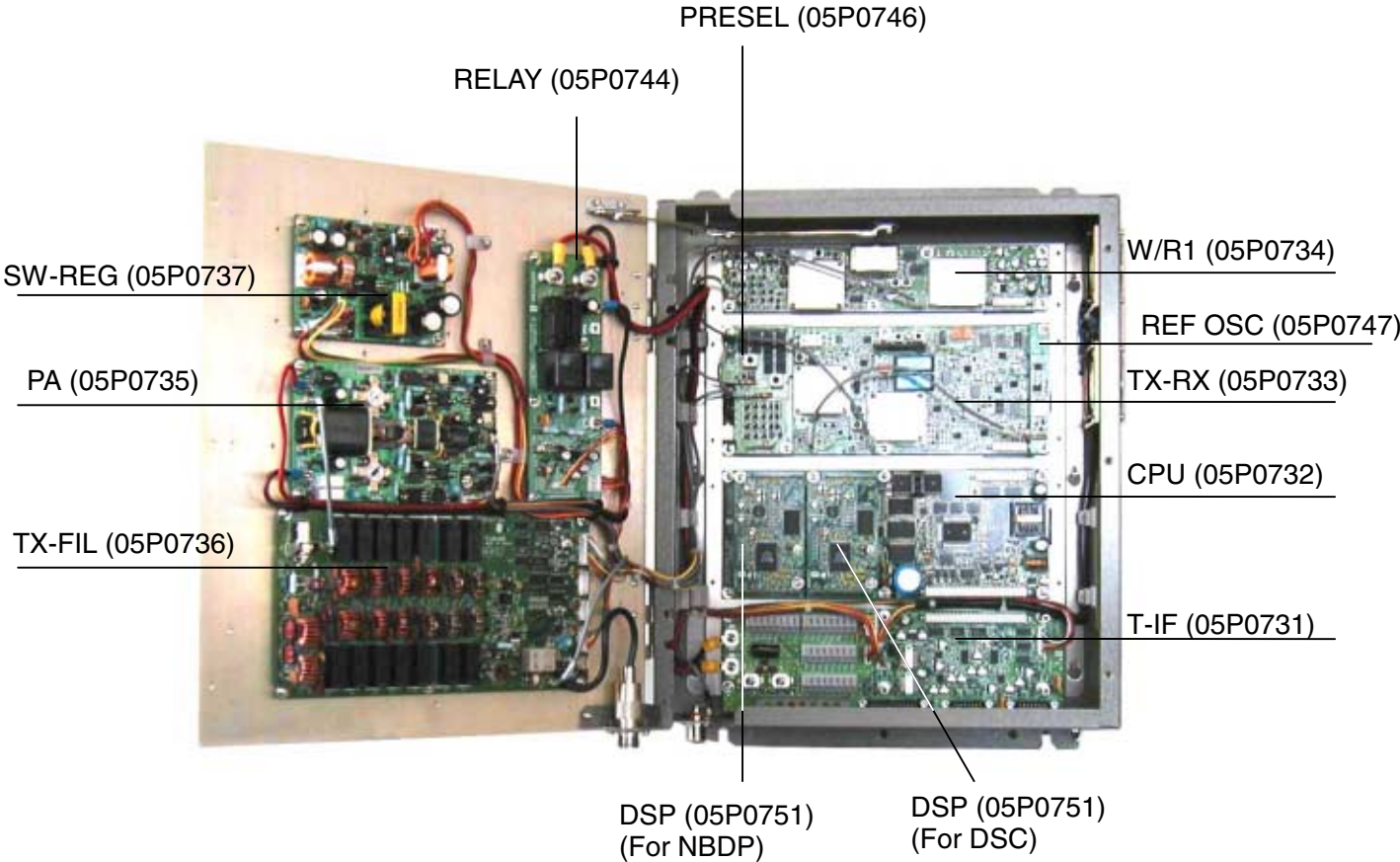

Fig.2.3.4 Transceiver unit with shield covers removed

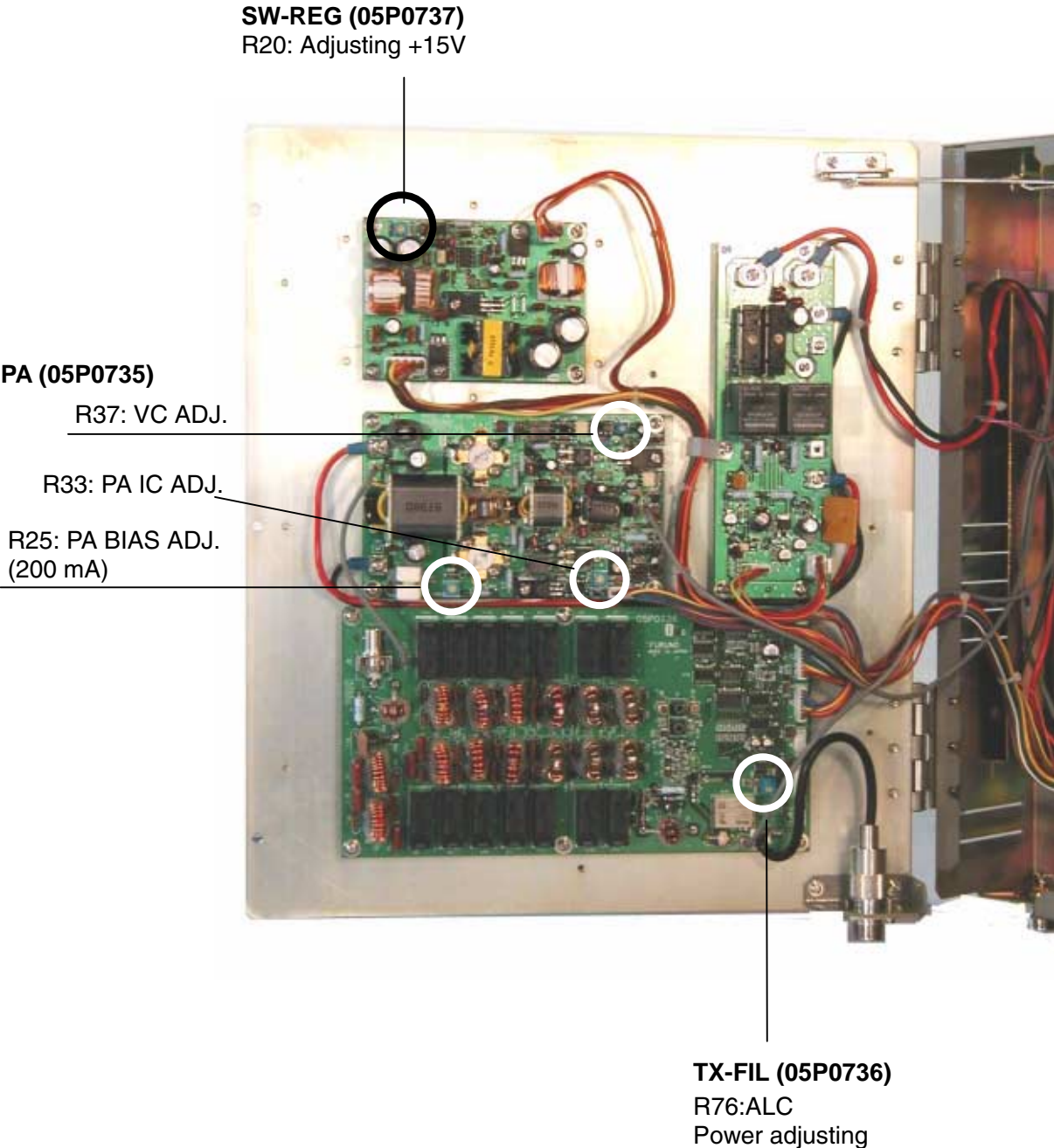

Fig.2.3.5 Backside of the transceiver door

W/R (05P0734)

J3: When FAX-5 antenna is connected, select ACTIV. (Short circuit between 1 and 2.)

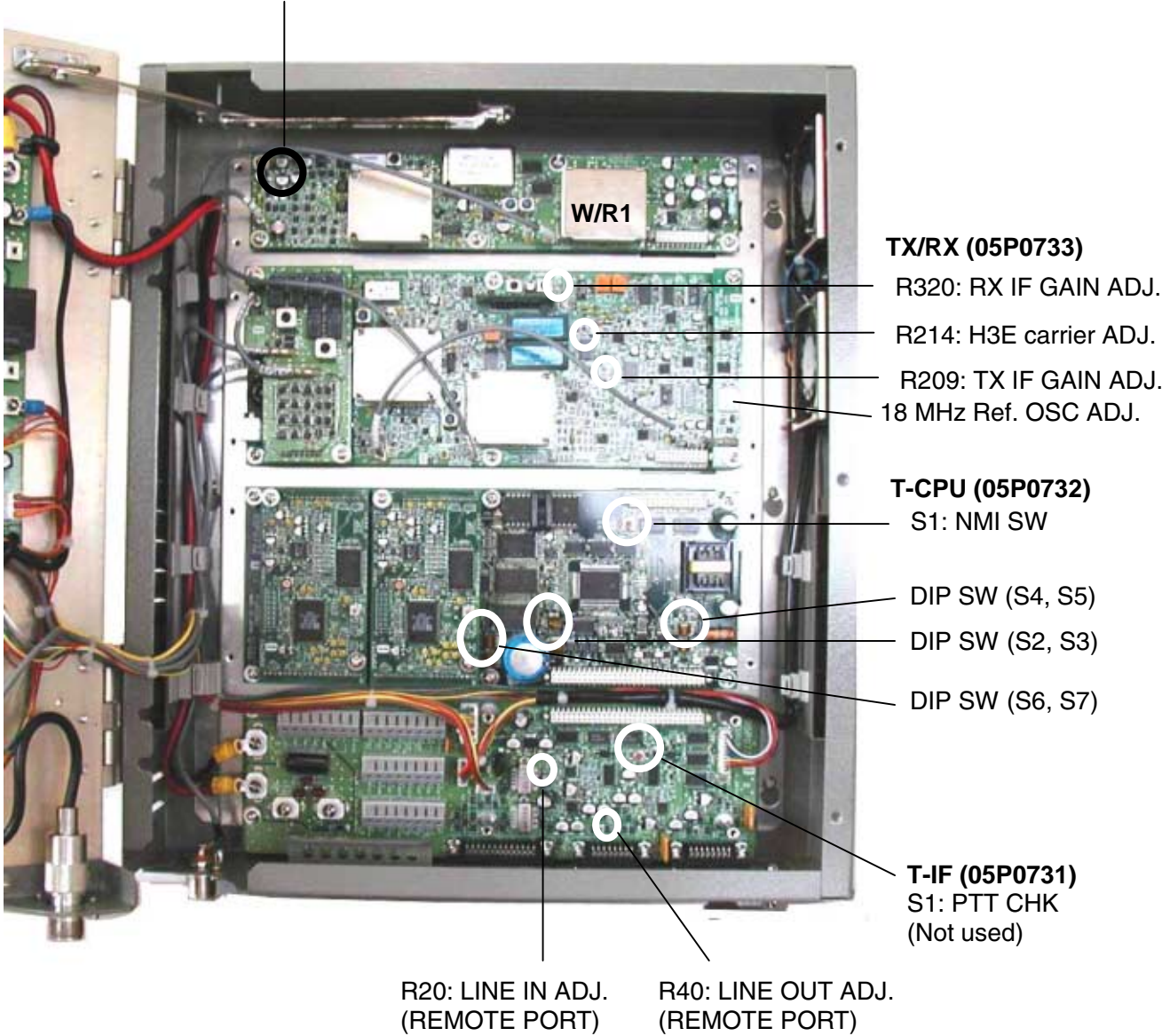

Fig.2.3.6 Inside of Transceiver unit

2.4 Boards in Transceiver Unit

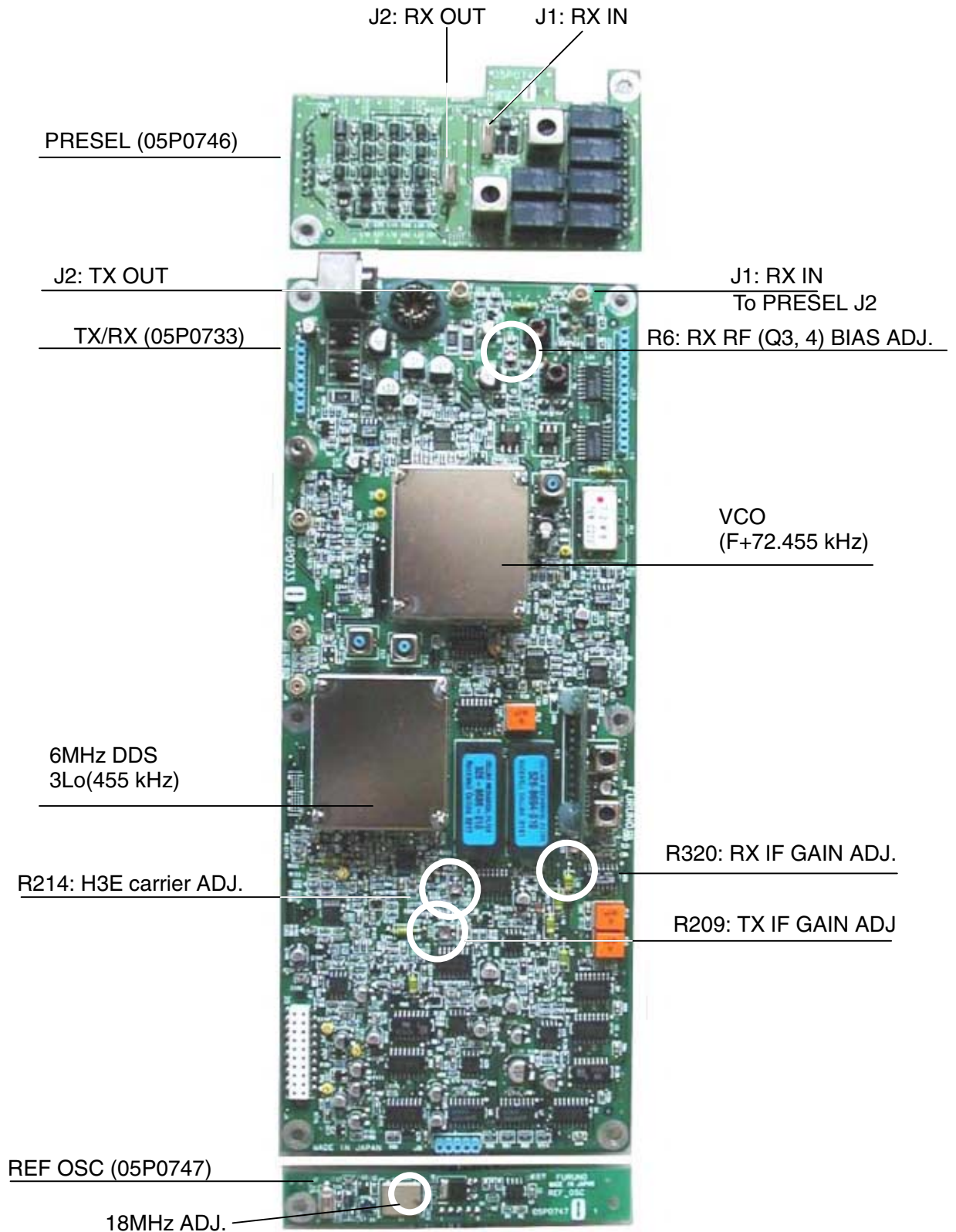

Fig.2.4.1 TX/RX (05P0733) board, FS-1570/2570

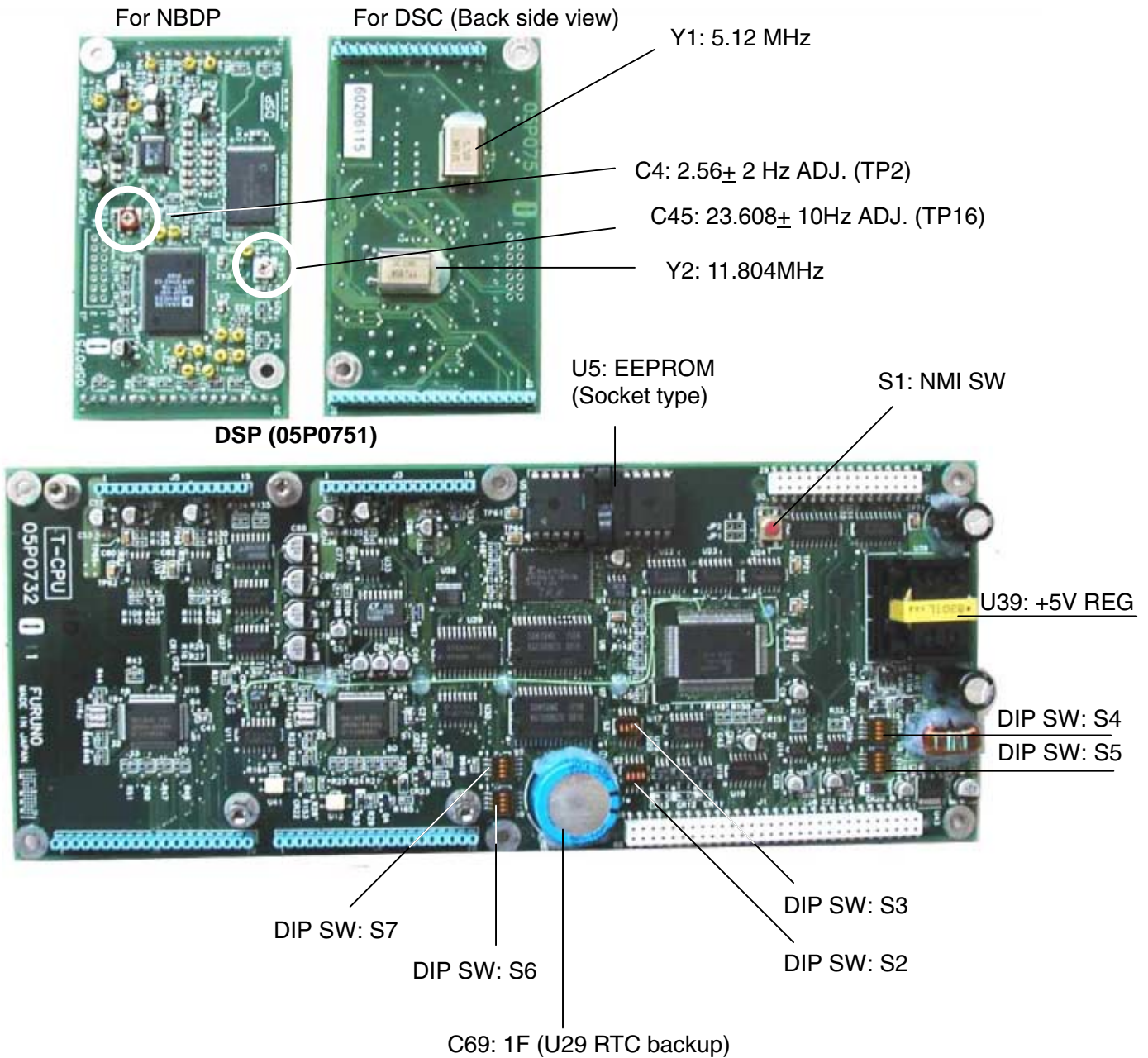

Fig.2.4.2 CPU (05P0732) board, FS-1570/2570

JP3: When FAX-5 antenna is connected, select ACTIV.
(Short circuit between 1 and 2.)

VCO
(F+54.455 kHz)



6 MHz DDS
3Lo(455 kHz)

Fig.2.4.3 W/R 1, 2 (05P0734) board, FS-1570/2570

L4
(To adjust BIAS, cut L4 and connect an ammeter.)

R37: VC ADJ.

J3: PA OUT

J2: PA IN



R25: PA BIAS ADJ.
(200 mA)

R33: PA IC ADJ.

Fig.2.4.4 PA (05P0735) board, FS-1570

L4: To adjust BIAS, cut L4 and connect an ammeter.

R26: VC ADJ.

J3: PA OUT

J2: PA IN

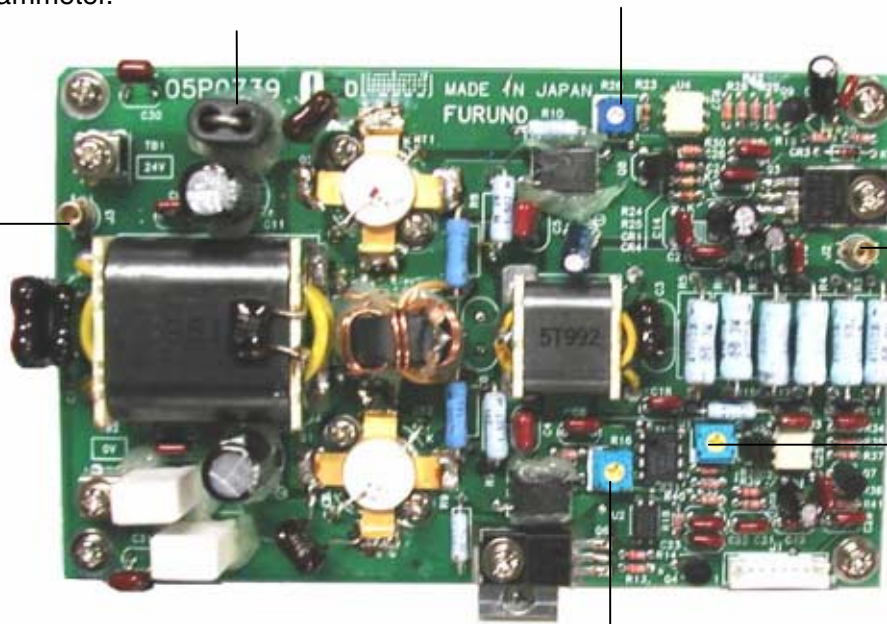

R33: PA IC ADJ.

R16: PA BIAS ADJ. (200 mA)

Fig.2.4.5 PA (05P0739) board, FS-2570

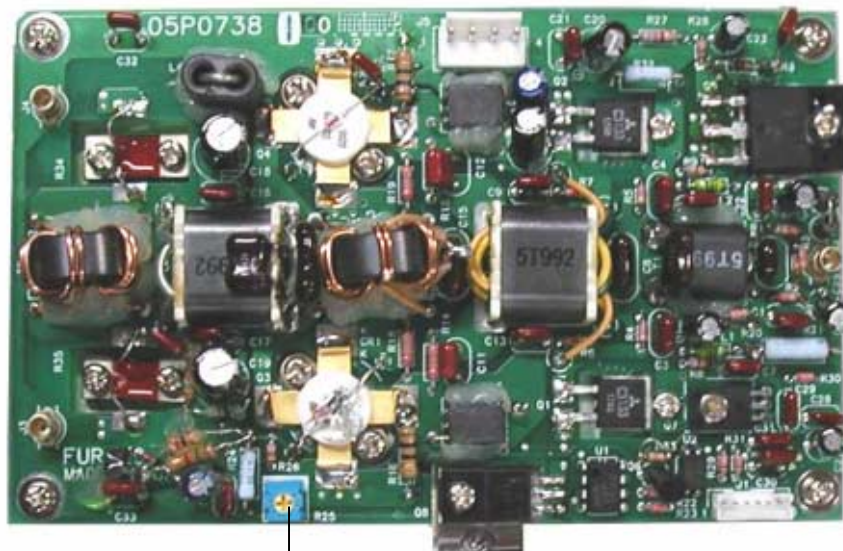

R25: DRV PA
BIAS ADJ. (100mA)

Fig.2.4.6. DRV (05P0738) board, FS-2570

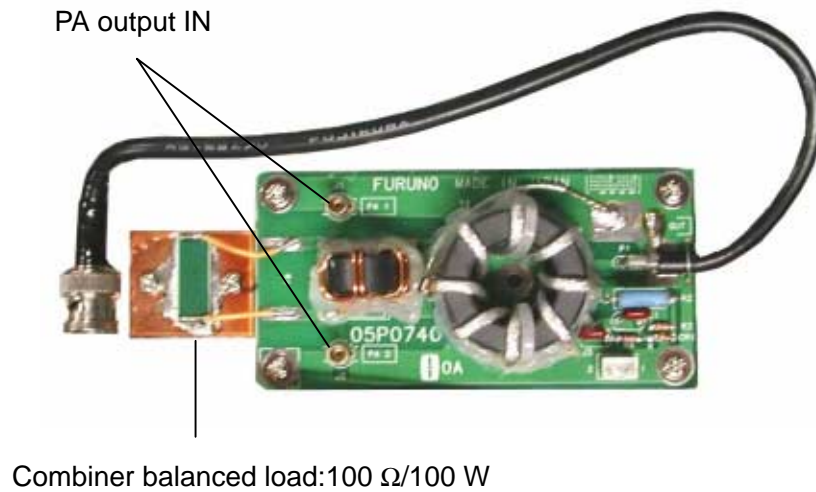
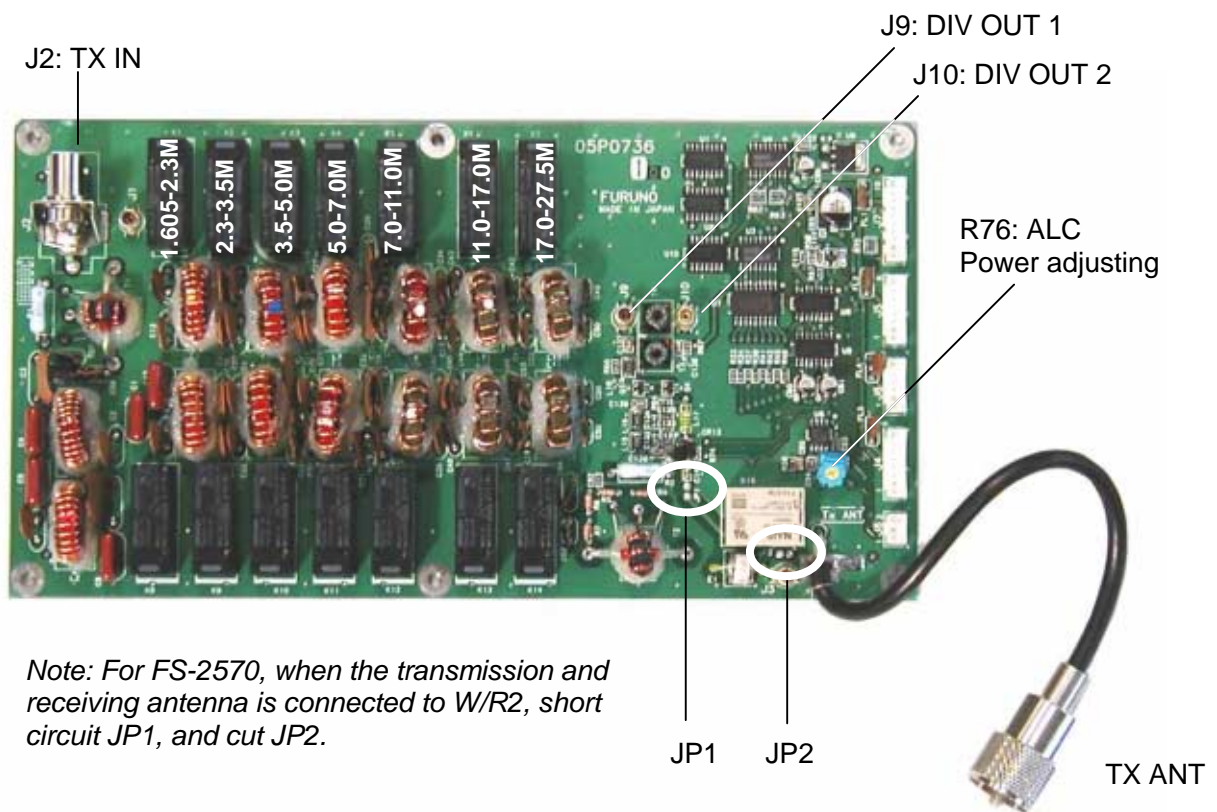
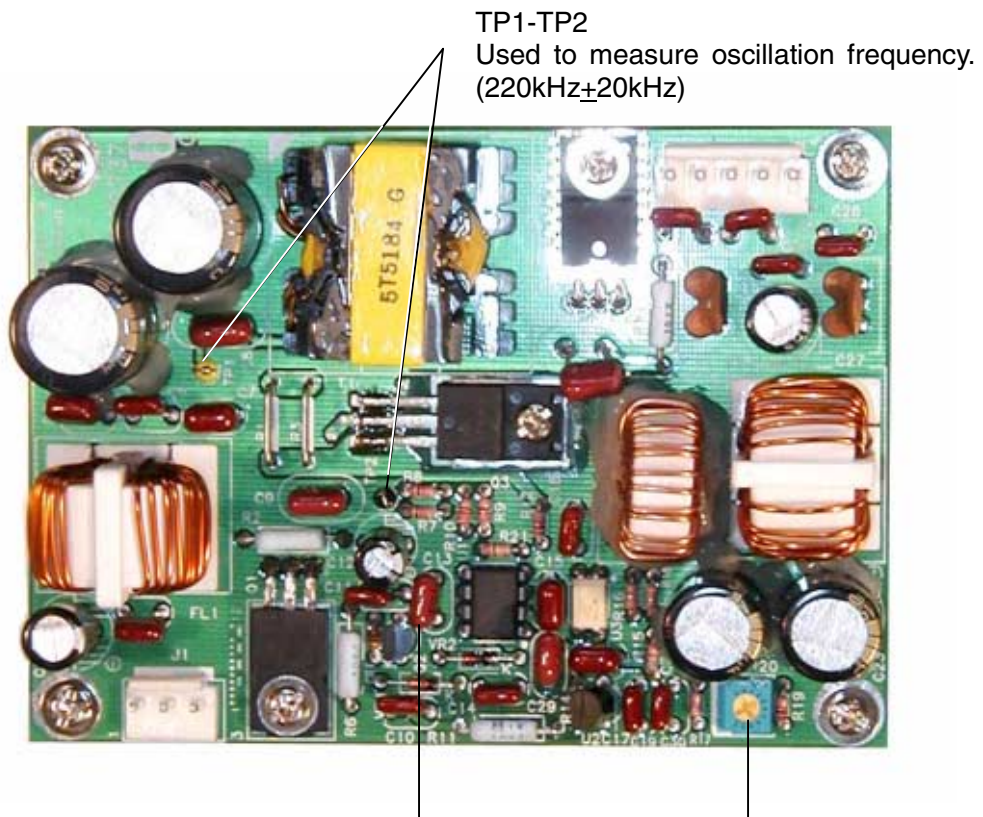

Fig.2.4.7 COMB (05P0740) board, FS-2570



Note: For FS-2570, when the transmission and receiving antenna is connected to W/R2, short circuit JP1, and cut JP2.

Fig.2.4.8 TX-FIL (05P0736) board, FS-1570/2570



C13: 220 pF (For oscillation frequency) R20: Adjusting +15V

Fig.2.4.9 SW-REG (05P0737) board, FS-1570/2570

RT2 (Polyswitch soldered to opposite side on production sets): 900 mA

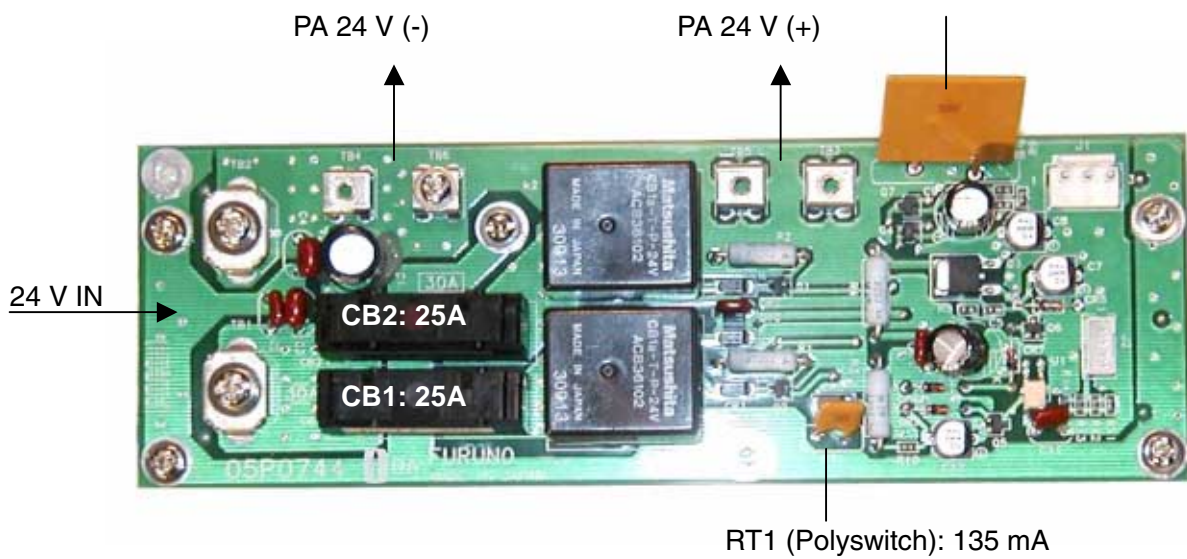
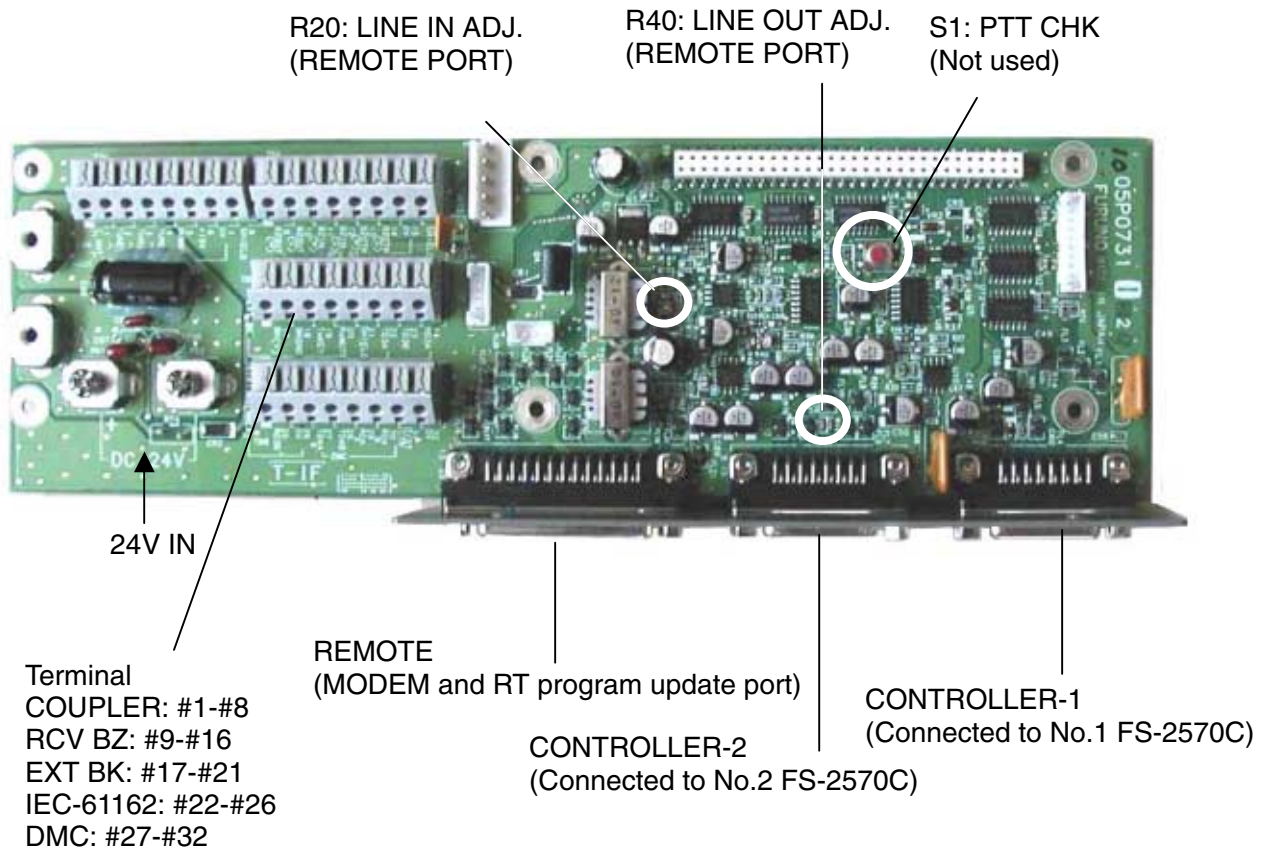

Fig.2.4.10 RELAY (05P0744) board, FS-1570/2570



*Note: No.1 FS-2570C has high priority .
(The system power is turned on/off only by No.1 control unit.)*

Fig.2.4.11 T-IF (05P0731) board, FS-1570/2570

2.5 Antenna coupler

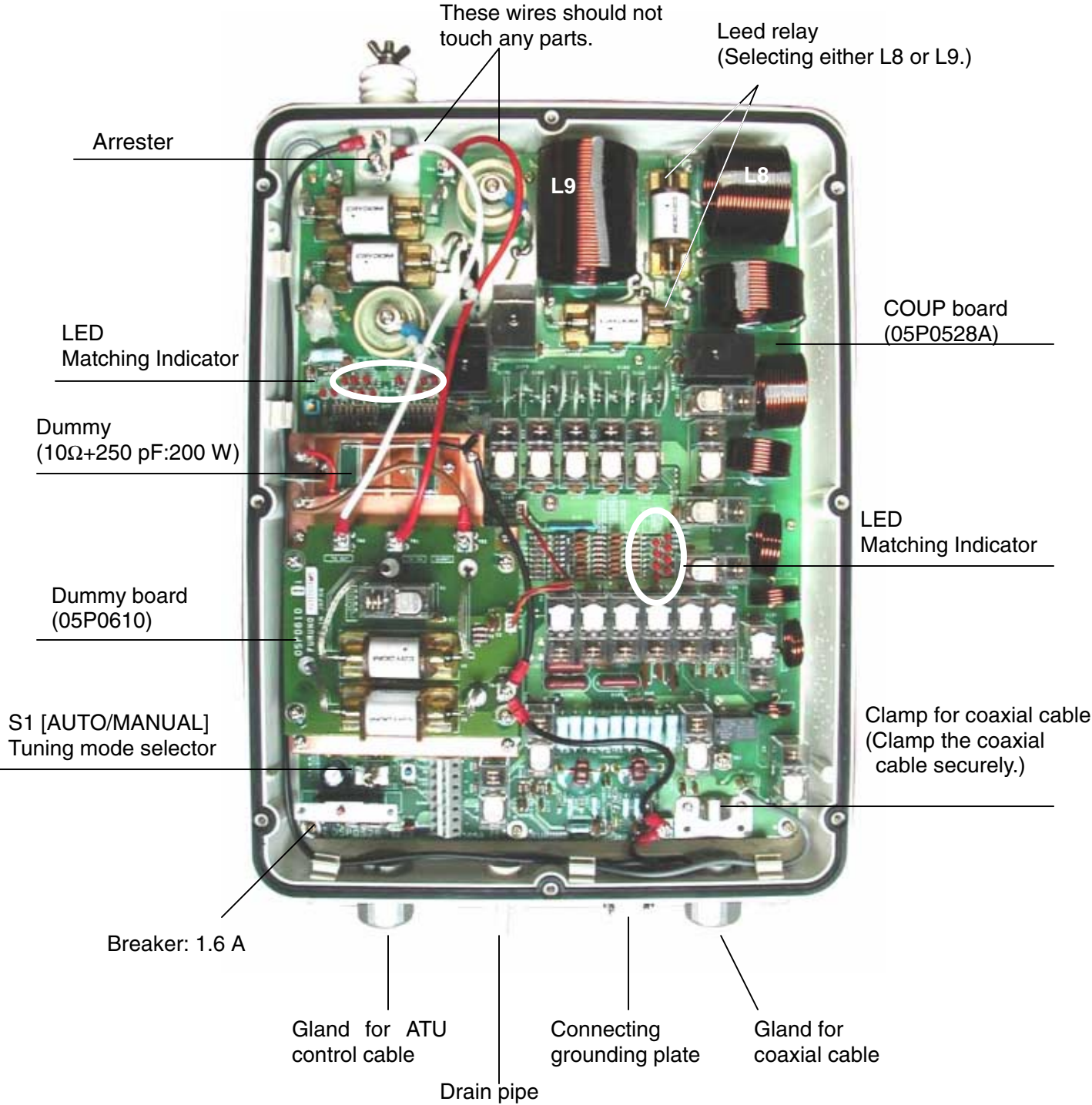

Fig.2.5.1 Antenna coupler, AT-1560-25 (For 250 W)

Figure below shows the difference between AT-1560-25 and -15.

AT-1560-25: Leed relay used

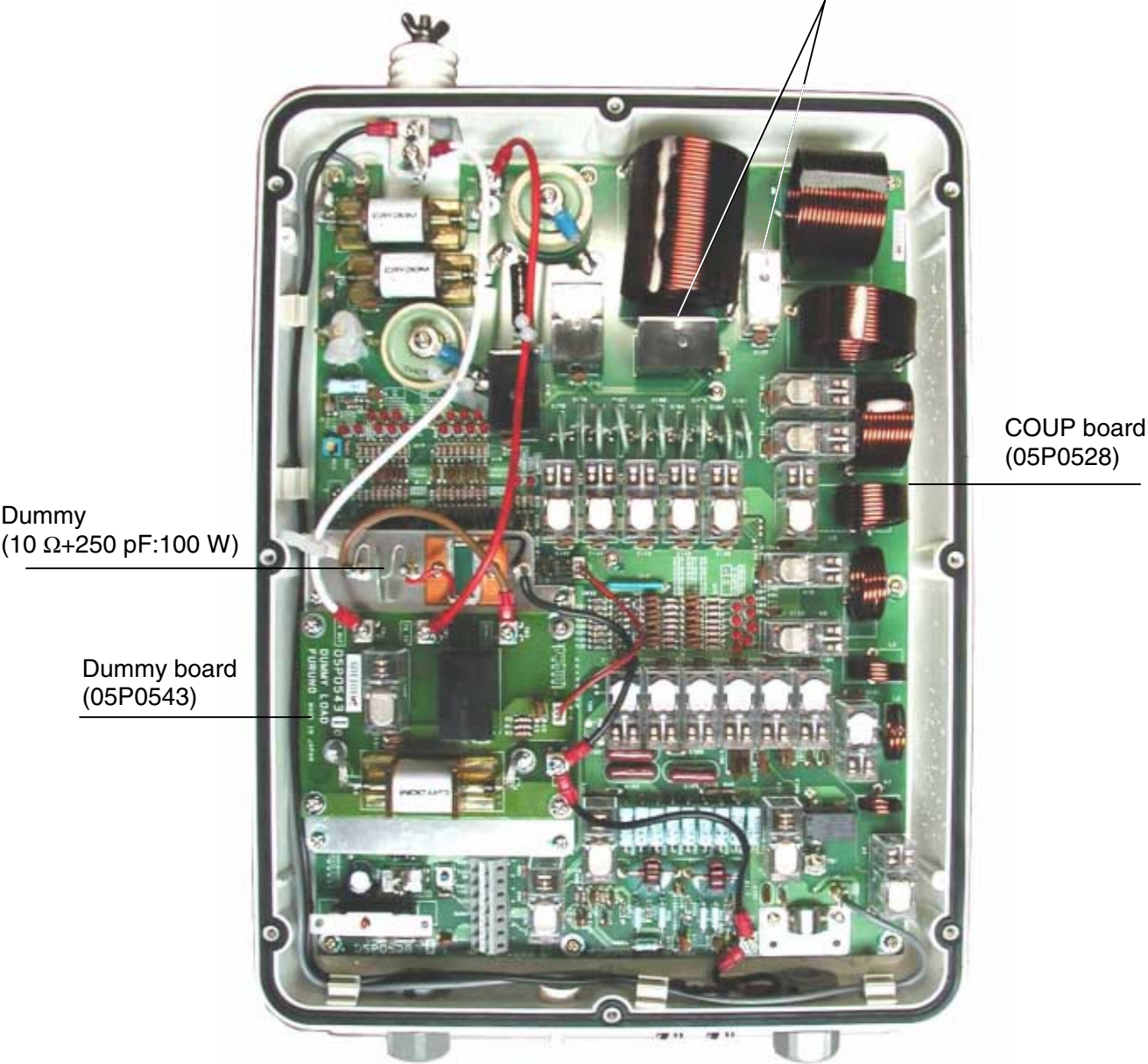

Fig.2.5.2 Antenna coupler, AT-1560-15 (For 150 W)

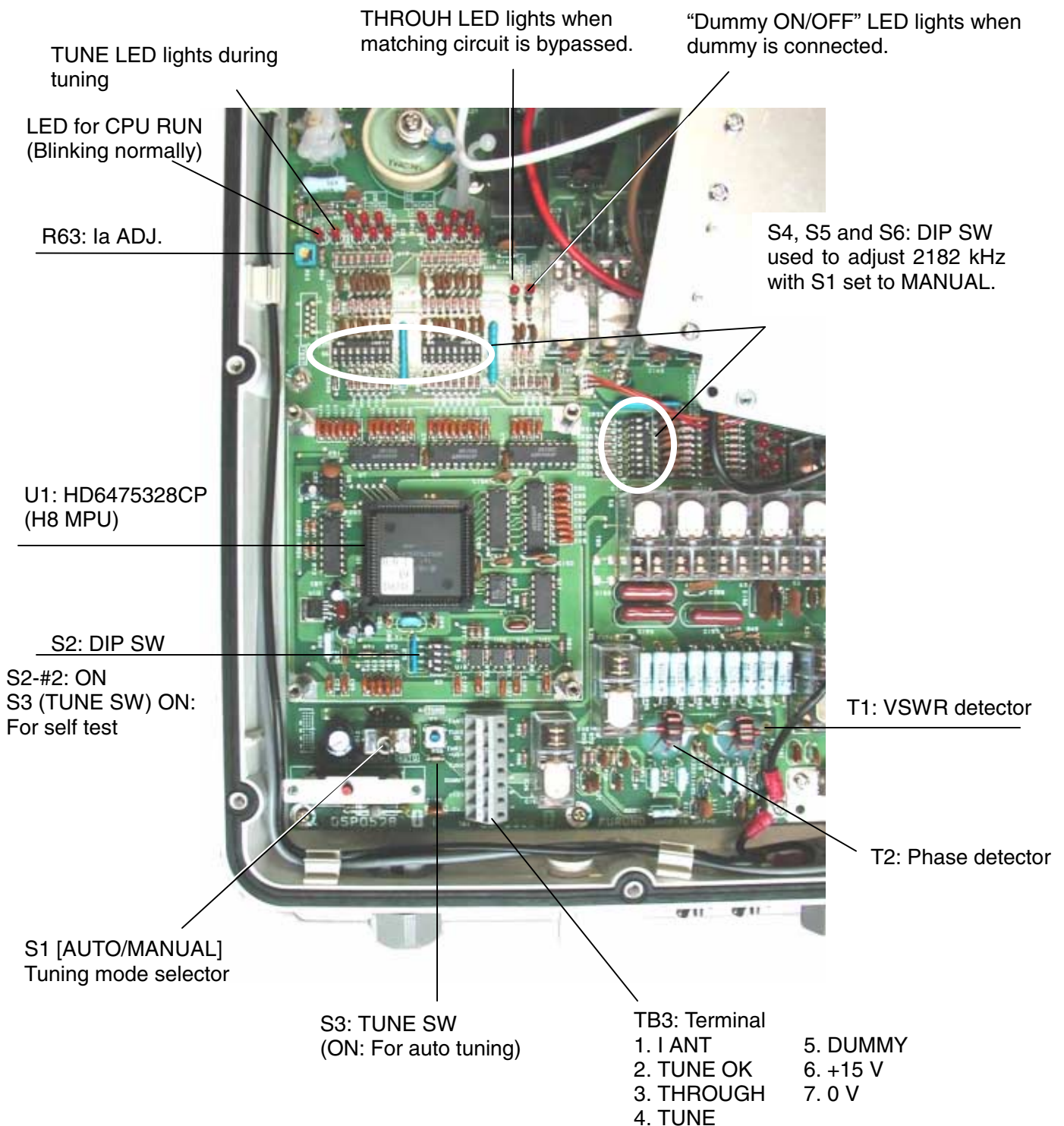

Fig.2.5.3 AT-1560-15/25 with dummy board removed

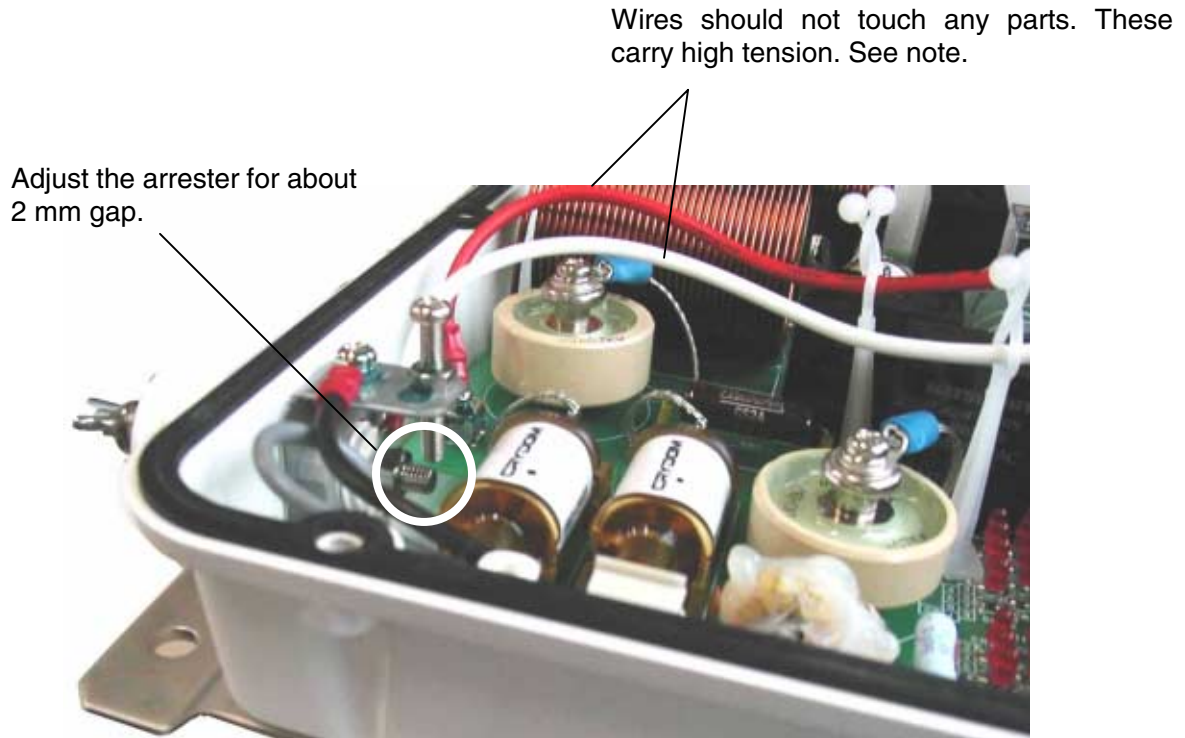

Fig.2.5.4 Parts around antenna terminal



Note; High voltage presents at the antenna terminal and associated parts. If the wires touch the parts, leaking will result.

The table below shows the type and code number of the relay to be used in the matching circuit.

Model	Parts No.	Type	Code no.
AT-1560-25	K1 to K14, K16, K17, K20 to K22	G2R-1A-E-DC12V	000142953
AT-1560-15	K1 to K12, K16, K17, K20 to K22		
AT-1560-25	K13, K18, K19	JC-2AF-DC12V	000106216
AT-1560-15	K15, K18, K19		
AT-1560-25	K14, K15, K27, K28	FRD12023	000106069
AT-1560-15	K27, K28		

2.6 Terminal unit, IB-583

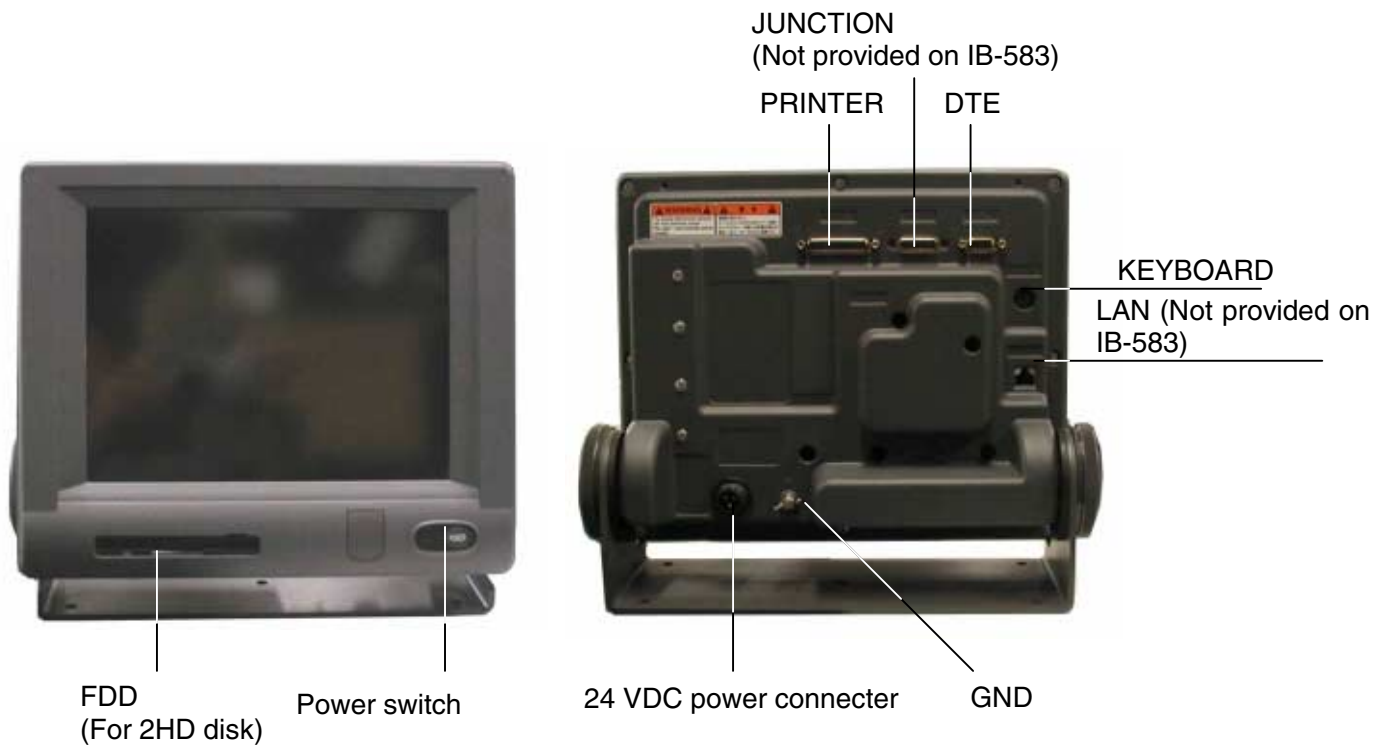

Fig.2.6.1 Terminal unit, Front and rear views



Fig.2.6.2 Dimensions

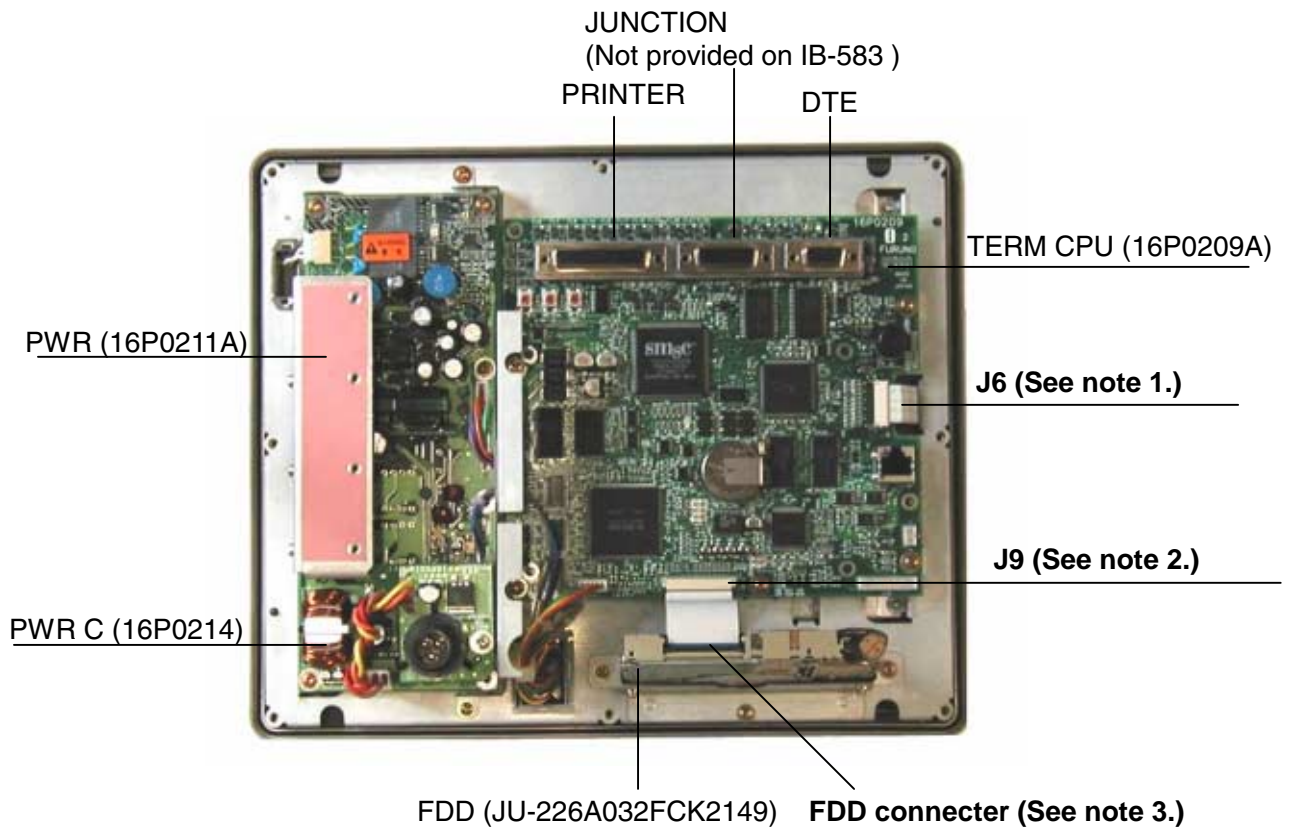

Fig.2.6.3 Terminal unit with cover removed

Note 1) Disconnecting flat cable from J6

To disconnect the flat cable, gently, set the locking tab to vertical position and then pull out the cable from the connector. Excess force will damage the connector tab. To connect the cable, reverse the above procedure.

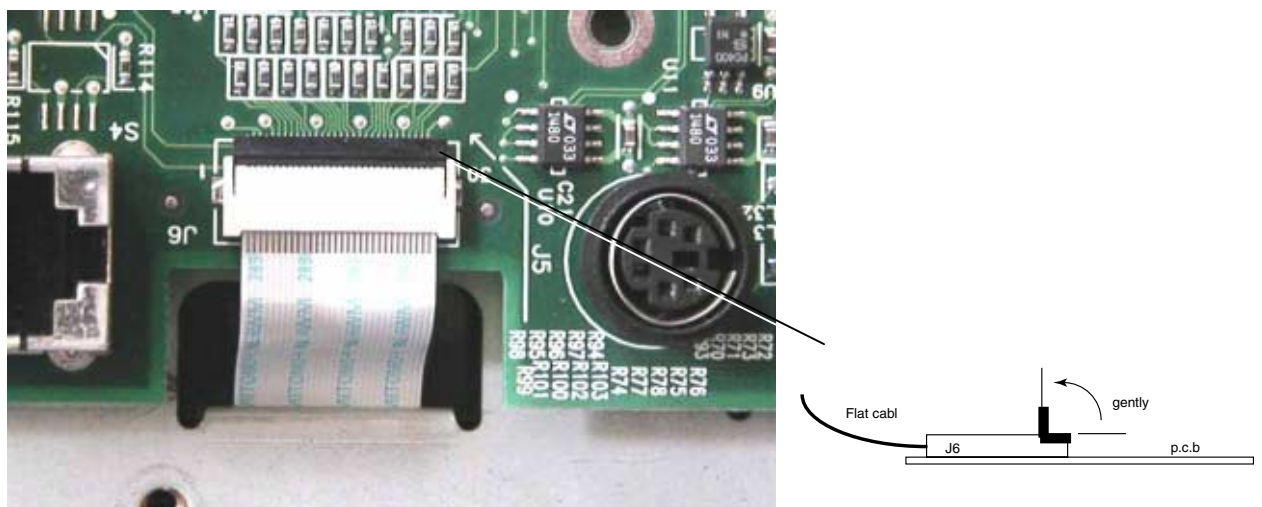

Fig.2.6.4 Flat cable connector, J6

Note 2) Disconnecting flat cable from J9

To disconnect the flat cable;

1. Release the locking tabs by pushing the tabs toward the cable about 1 mm gently.
Excess force will damage the connector.
2. Pull out the cable.

To connect the cable, reverse the above procedure.

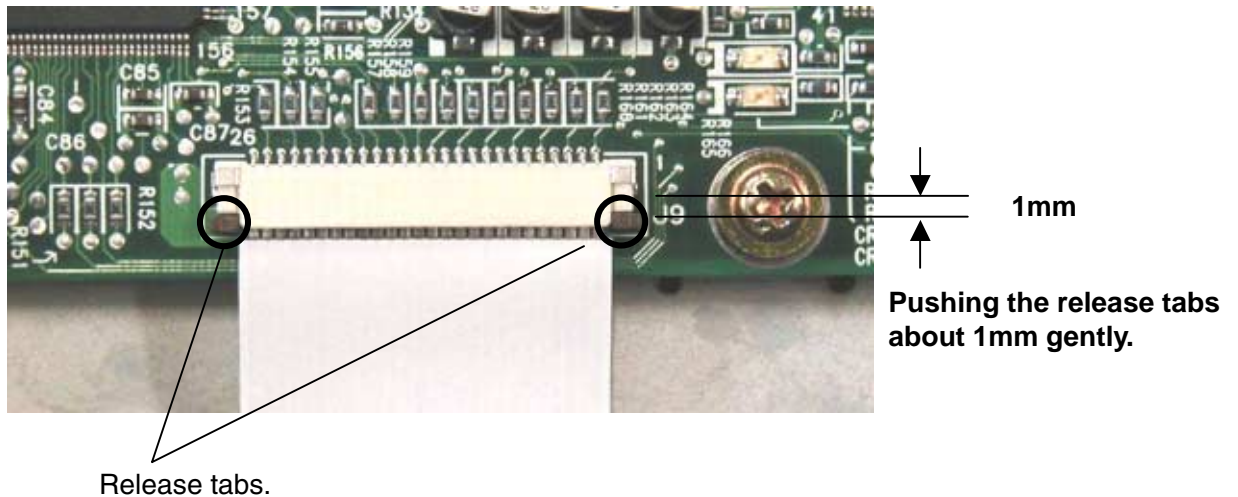

Fig.2.6.5 Flat cable connector, J9

Note 3) Disconnecting flat cable from FDD connector

To disconnect the flat cable;

1. Release the locking tabs by pushing the tabs toward the cable about 1 mm gently.
Excess force will damage the connector.
2. Pull out the cable.

To connect the cable, reverse the above procedure.

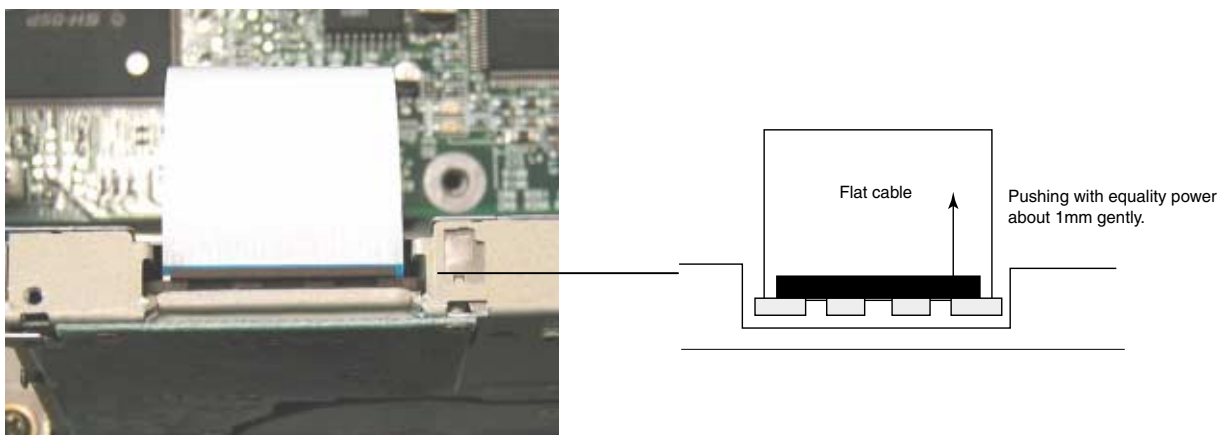

Fig.2.6.6 FDD connector

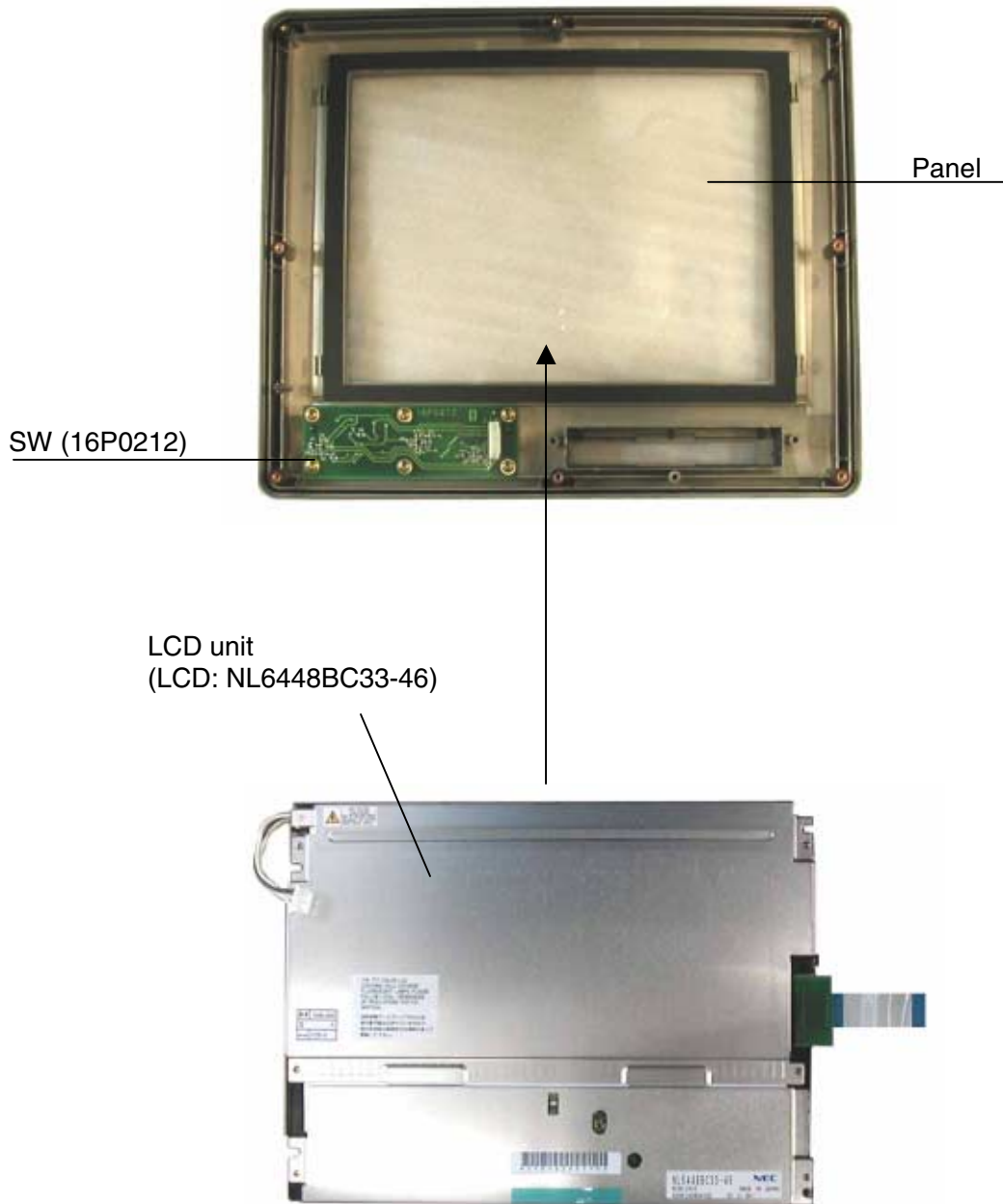

Fig.2.6.7 Panel with LCD unit removed

2.6.1 Boards in Terminal Unit

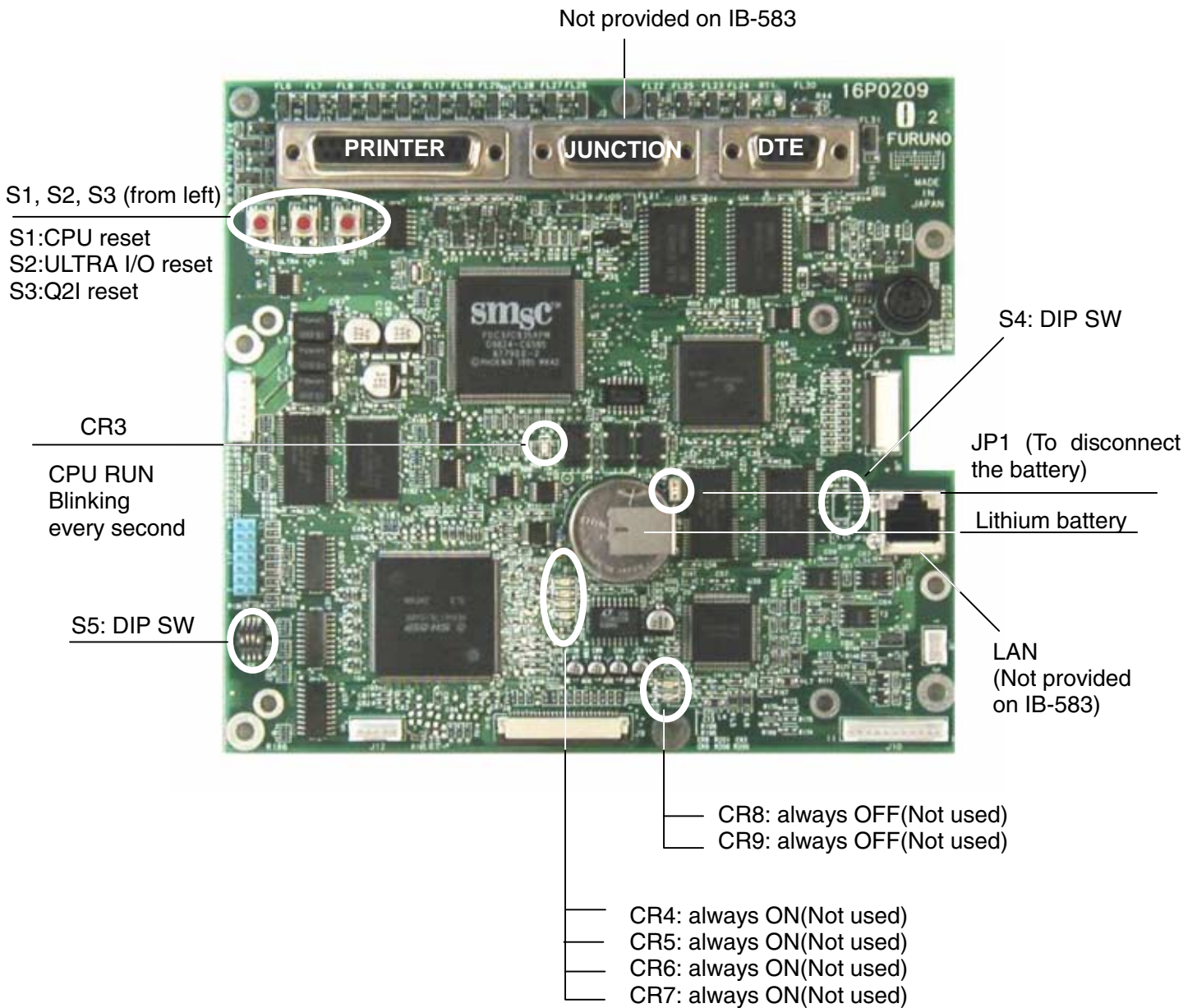

Fig.2.6.8 TERM CPU (16P0209A) board



Fig.2.6.9 PWR (16P0211A) board

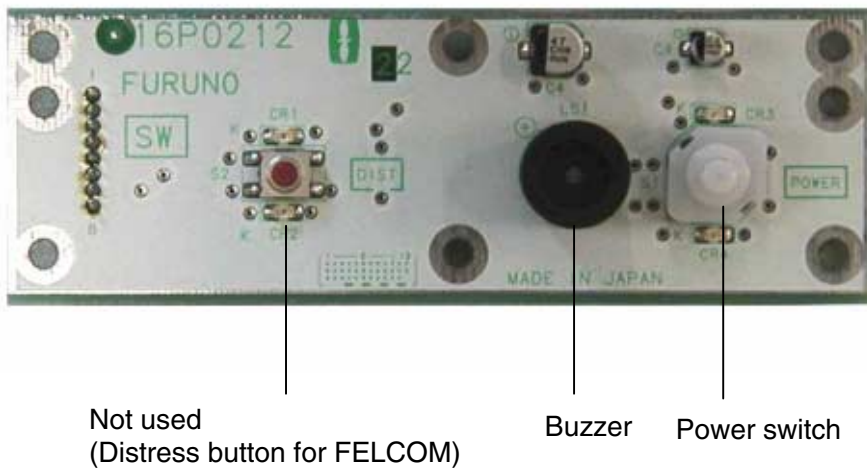

Fig.2.6.10 SW (16P0212) board

2.7 Handset (HS-2001)



PTT switch

Fig.2.7.1 Handset, HS-2001

ON/OFF hook detecting magnet

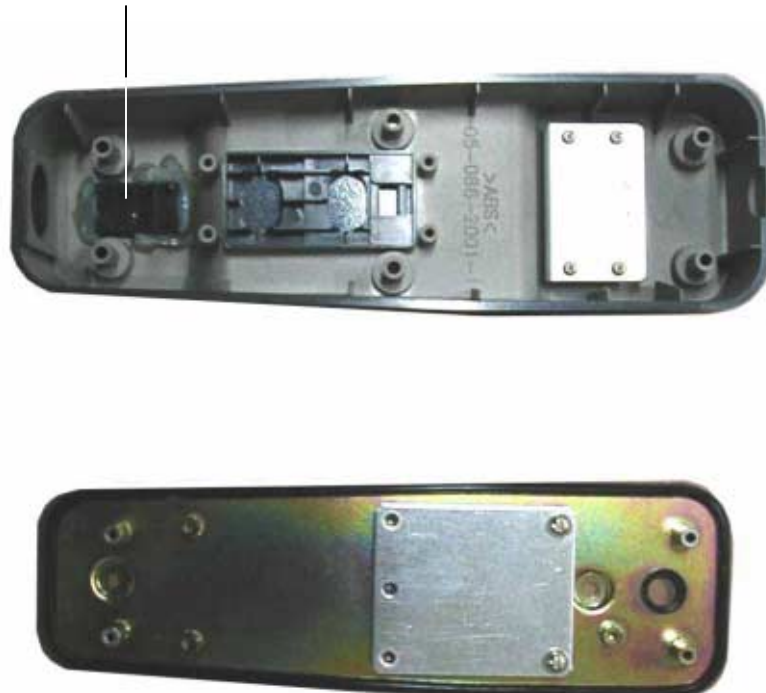

Fig.2.7.2 Handset hunger

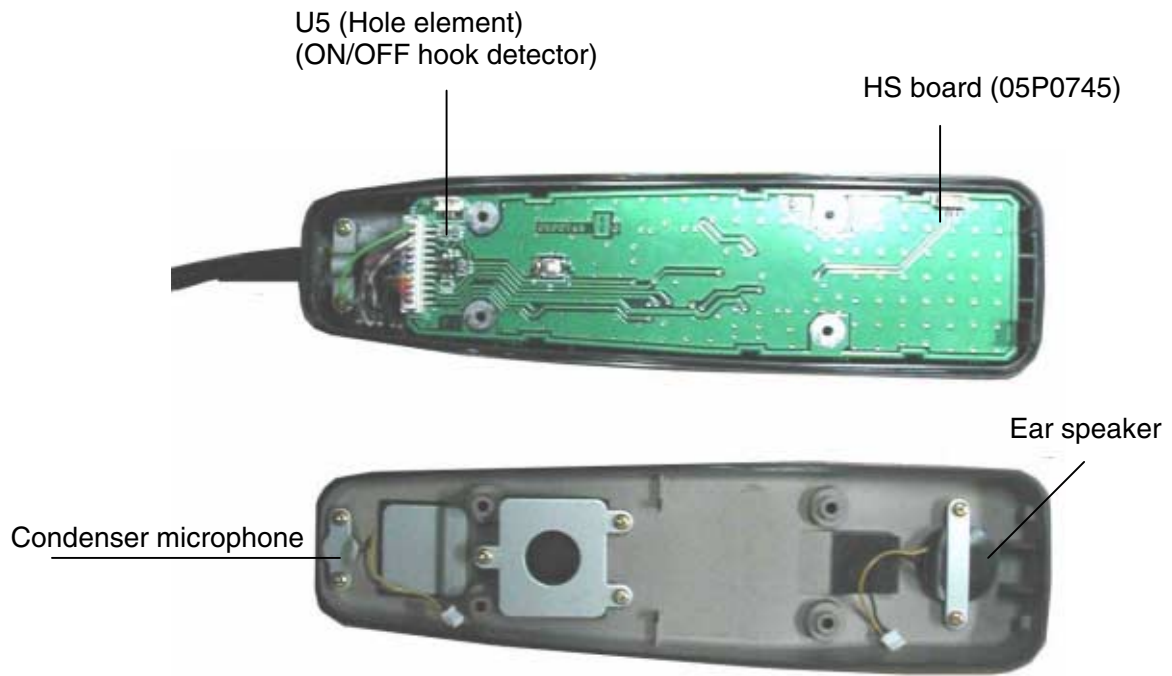

Fig.2.7.3 Handset

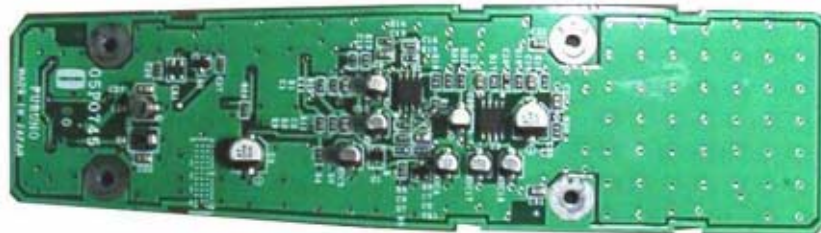

Fig.2.7.4 HS board (05P0745), parts side

The radiotelephone and the DSC are set up through “RT SETUP” and “DSC SETUP” menus respectively. Either No.1 controller or No.2 controller can be used for setting up. The DIP switch on T-CPU board is set according to the system configuration.

This chapter also describes how to enter MMSI.

3.1 MMSI Number, Model and Group ID

MMSI and Model are registered through “EEROM clear” menu and Group ID through “Message file entry” menu.

3.1.1 MMSI Number (MMSI CLEAR)

The MMSI is changed by following the procedure below.

1. Turn on the system and then press “S1 (NMI SW)” on T-CPU board. “EEROM clear” appears.

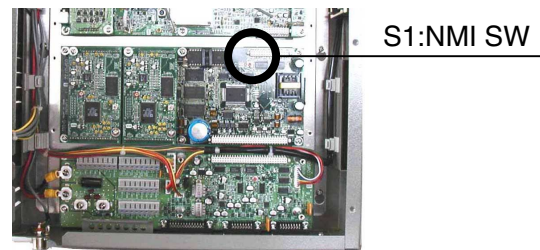
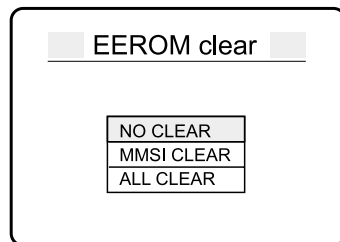

2. Enter password ([x][x][x][x][x][x]).
3. Move the cursor to “MMSI CLEAR” and then press [ENT].

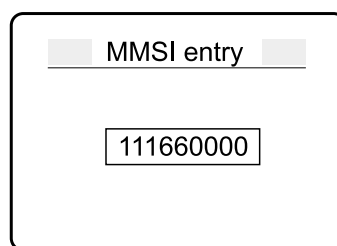

4. Enter MMSI of own ship and then press [ENT].
5. Turn off the system and turn it on again.

3.1.2 Model (ALL CLEAR)

Following steps delete user channel data, the communication log and change the system setting to the default. To check the model;

1. Turn on the system and then press “S1” switch on T-CPU board. “EEROM clear” appears.

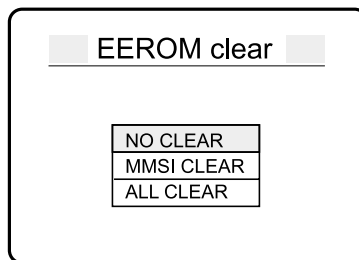

2. Enter password ([x][x][x][x][x][x]).
3. Move the cursor to "ALL CLEAR" and then press [ENT].
4. Select the model and then press [ENT].

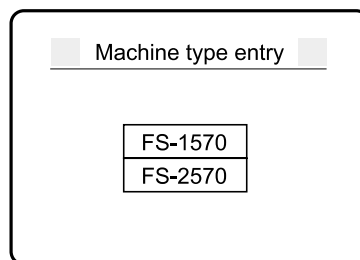

Difference between FS-1570 and FS-2570 is the contents of the self-test menu and default power data

5. Enter MMSI of own ship and then press [ENT].

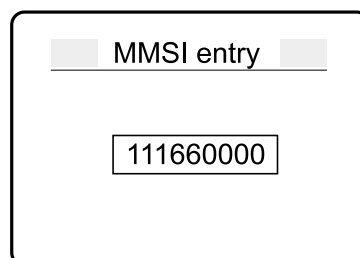

6. Turn the system off and turn it on again.

3.1.3 Group ID

The group ID is registered for up to 150 groups from DSC setup menu.

1. Press [SETUP] on DSC display.
2. Move the cursor over “MESSAGE” and then press [ENT]. “Message File entry” appears.
3. Complete the “Message file entry” display.

- CALL TYPE: Set to “GROUP CALL”.
- GROUP ID: Far left digit is always 0 (one leading zero).

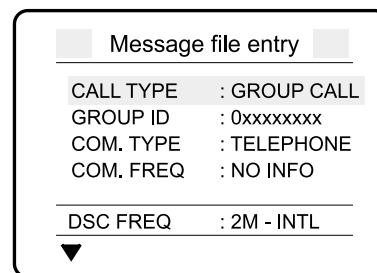

4. Move down the cursor until the “FILE NAME” and “FILE NUMBER” lines are displayed.
5. Enter file name and file number.

- FILE NAME: 16 character long
- FILE NUMBER: Any number from 001 to 999, except from 800 to 899.

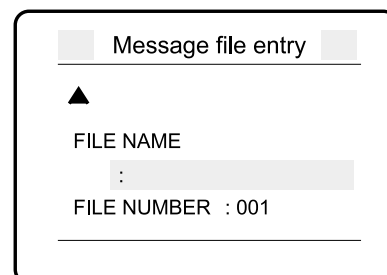

6. Press [ENT]. When the “File name” and “File number” are ones that already exist, “Duplicate number (name)!” prompt appears. To overwrite, press [ENT].

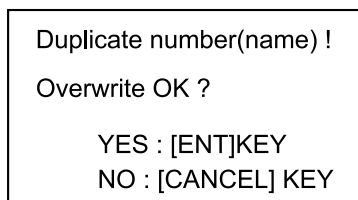

When the registration is carried out correctly, the pup-up below is displayed.

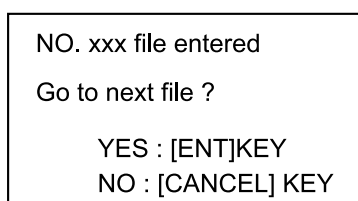

3.2 RT SETUP

The RT is set up through RT SETUP menu as below.

1. Press [SETUP] in RT display. “Setup menu” appears.

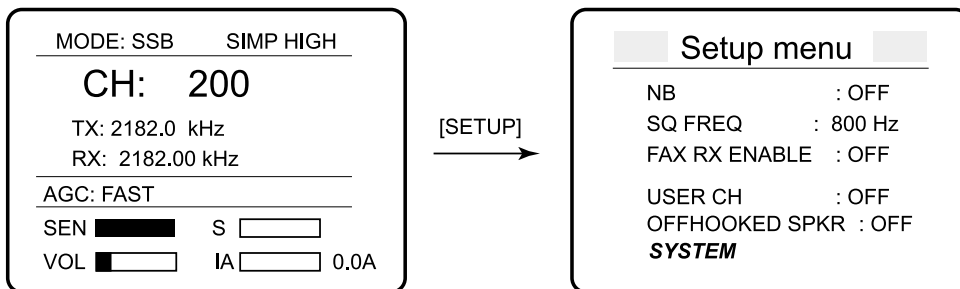

2. Select the item by the dial key. To show “SYSTEM” menu, the password is needed.
3. Press [ENT] and then the pop-up display appears for setting.
4. Select the option by the dial key.
5. To register the settings, press [ENT].

To open “SYSTEM” menu:

1. Move the cursor on “SYSTEM” and then press [ENT]. “System setup” appears with “PROTECTION ON” at the bottom of the display.
2. Enter the password ([x][x][x][x][x][x]). The message at the bottom changes to “PROTECTION OFF” and items in the menu are displayed.

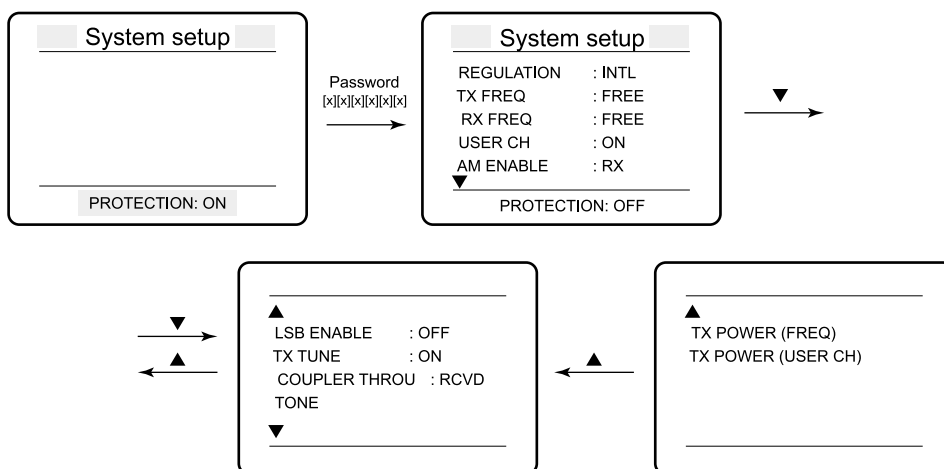

Table 3.2.1 lists the RT Set up menu.

Table 3.2.1 RT Set up menu

Item		Option				Remarks
1	NB	OFF	ON			
2	SQ FREQ	500 Hz to 2000 Hz (800 Hz)				
3	FAX RX ENABLE	OFF	ON			
4	USER CH	See page 3-11.				Displayed when "USER CH" in SYSTEM menu is set to ON.
5	OFFHOOKED SPKER	OFF	ON			
SYSTEM		Password is needed to set following items.				
6	REGULATION	INTL				Reserved for future use
7	TX FREQ	FREE	MARINE	ITU/USER	USER	
8	RX FREQ	FREE	MARINE	ITU/USER	USER	
9	USER CH	OFF	ON			
10	AM ENABLE	OFF	TRX	RX		
11	LSB ENABLE	OFF	ON			
12	TX TUNE	OFF	ON			
13	COUPLER THROU	OFF	RCVD	DIFF		
14	TONE	See page 7-9.				
15	TX POWER (FREQ)	See page 7-4.				
16	TX POWER (USER CH)	See page 7-6.				

Note that the "default" settings are screened.

1. NB (ON/OFF)

The noise blanker (NB) is set to ON or OFF. The noise blanker, U15 on TX/RX board (05P0466) reduces pulse noise. In J2B (DSC and NBDP) and J3C (FAX) modes, the noise blanker is automatically set to OFF and no indication appears on the display.

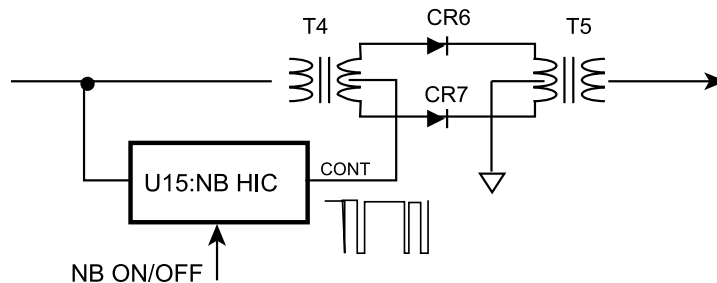

2. SQ FREQ. (500 Hz-2000 Hz)

The squelch circuit is controlled by AF signal in frequency, but not in the receiving signal level. The frequency lower than the preset value is recognized as audio signal and the higher frequency as noise.

In J2B (DSC and NBDP) and J3C (FAX) modes, the SQ is automatically set to OFF and no indication appears on the display.

The C-CPU in the controller unit generates MUTE signal by which the input signal of the AF power amplifier, U7 on T-IF board is switched on and off.

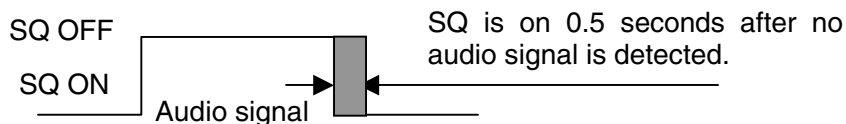

3. FAX RX ENABLE (ON/OFF)

The weather FAX is set to ON or OFF. When FAX RX ENABLE is set to ON, the MODE pop-up menu contains "FAX" line. The FAX signal, $1900\text{Hz} \pm 400\text{Hz}$, $0\text{dBm}/600\ \Omega$ is connected to #10 and #11 of [REMOTE] port.

4. USER CH (USER CH ENTRY)

See page 3-11.

5. OFFHOOK SPKER (ON/OFF)

The ON/OFF Hook of the handset is detected and the speaker is set to ON/OFF by this setting. The table below shows the speaker on/off setting based on “OFFHOOKED SPKER” setting and the handset condition.

OFFHOOKED SPKER setting	Handset	Speaker
Off	Off Hook	Off
	On Hook	On
On	On/Off Hook	On

The following items are in “SYSTEM” menu.

6. REGULATION (INTL): Reserved for future use

The RT is automatically set in accordance with local regulations. Table 3.2.2 lists the default settings for each regulation. INTL stands for International.

Table 3.2.2 Default setting for each regulation

Menu		Regulations		
		INTL	xx	xx
1	NB	OFF		
2	SQ FREQ	800Hz		
3	FAX RX ENABLE	OFF		
4	USER CH	—		
5	OFFHOOK SPKER	OFF		
SYSTEM: Password is needed to set following items.				
6	REGULATION	INTL		
7	TX FREQ	FREE		
8	RX FREQ	FREE		
9	USER CH	ON		
10	AM ENABLE	RX		
11	LSB ENABLE	OFF		
12	TX TUNE	ON		
13	COUPLER THROU	RCVD		
14	TONE	—		
15	TX POWER (FREQ)	—		
16	TX POWER (USER CH)	—		

7. TX FREQ. (FREE, MARINE/USER, ITU/USER)

The transmission frequency is registered.

FREE

TX frequency is selected in the range from 1.605 MHz to 27.5 MHz and typed in before transmission. The emission mode is selectable for each frequency.

The registered USER CH and ITU channel are also used to set the transmission frequency.

MARINE

TX frequency is a marine frequency as below.

The registered USER CH and ITU channel are also used to set the transmission frequency.

Marine band

1,605 – 4,438	6,200 – 6,525	8,195 – 8,815
12,230 – 13,200	16,360 – 17,410	18,780 – 19,800
22,000 – 22,855	25,070 – 26,175 kHz	

ITU/USER

TX frequency is the registered USER CH and ITU channel.

USER

TX frequency is the registered USER CH only.

8. RX FREQ. (FREE, MARINE/USER, ITU/USER)

The receiving frequency is registered.

FREE

RX frequency is selected in the range from 100 kHz to 29,999.99 MHz and typed in for reception. The mode is selectable for each frequency.

The registered USER CH and ITU channel are also used to set the receiving frequency.

MARINE

RX frequency is a marine frequency in the following ranges.

The registered USER CH and ITU channel are also used to set the receiving frequency.

Marine band

1,605 – 4,438	6,200 – 6,525	8,195 – 8,815
12,230 – 13,200	16,360 – 17,410	18,780 – 19,800
22,000 – 22,855	25,070 – 26,175 kHz	

ITU/USER

RX frequency is the registered USER CH and ITU channel.

USER

RX frequency is the registered USER CH only.

9. USER CH (ON/OFF)

When USER CH is set to ON, "USER CH" is registered and erased.
 When USER CH is set to OFF, "USER CH" is not displayed in RT SETUP menu.

10. AM ENABLE (ON, TRX, RX)

AM (H3E) mode is switched on or off.
 MODE pop-up display includes "AM" line when set to TRX and RX.

OFF: H3E transmission and reception are not allowed.

TRX: H3E transmission and reception are available.

RX: Only H3E reception is available.

11. LSB ENABLE (ON/OFF)

LSB transmission and reception are switched on and off. "LSB" line appears in MODE pop-up display when LSB ENABLE is set to ON.

12. TX TUNE (ON/OFF)

When TX TUNE is set to ON, the antenna tuner tunes the antenna automatically when the PTT switch or [0 TUNE] key is pressed, and when a call is made from DSC or NBDP terminal. The antenna coupler receives TUNE signal for tuning.

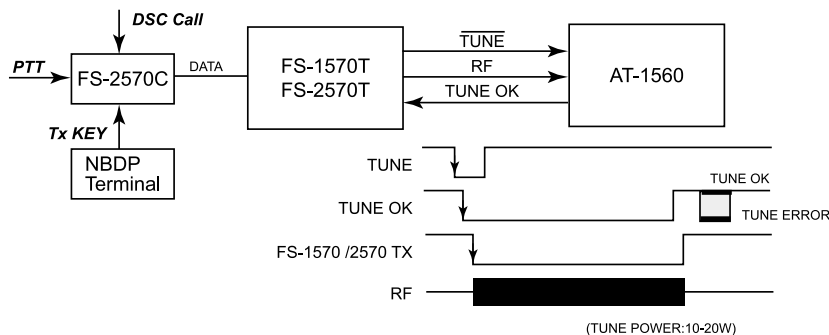

13. COUPLER THROU (OFF, RCVD, DIFF)

The receiving signal can bypass the tuning circuit in the antenna coupler.

OFF

The signal received by the antenna is sent to the transceiver unit through the tuning circuit in the antenna coupler.

RCVD

The received signal bypasses the tuning circuit in the antenna coupler.

DIFF

When the transmission frequency and the receiving frequency are different, the receiving signal bypasses the tuning circuit;

- 1) If the receiving frequency is 1.6 MHz or less.
- 2) If the receiving frequency is less than 4 MHz and different from the transmission frequency.
- 3) If the receiving frequency is 4 MHz or more and different 1.2 MHz from the transmission frequency.
- 4) With the RT scanning.

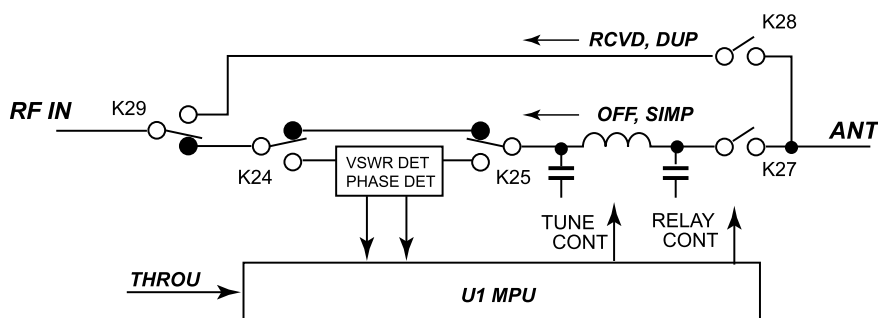

*When CR61 (THROUGH) on COUP board is on, the receiving circuit is "THROUGH".

14. TONE

See page 7-9.

15. TX POWER (FREQ.)

Output power is adjusted for each frequency. See page 7-4.

16. TX POWER (USER CH)

Output power is adjusted for user channels. See page 7-6.

3.2.1 USER CH Registration

A maximum of 255 user channels are registered for radiotelephone, NBDP and DSC calls. The user channels are available in the following menus.

- Compose Message
- “MESSAGE” in DSC SET UP menu
- “SCAN Freq. Setup (Routine frequency only)” in DSC SET UP menu

To register a user channel:

1. Press [SETUP] in RT display.
2. Select “USER CH “ in RT SETUP menu and then press [ENT]. If “USER CH” is not displayed, set “USER CH” in “SYSREM” menu to ON. See page 3-9.
3. Select “ENTRY” in “ENTRY/ERASE” pop-up display and then press [ENT].

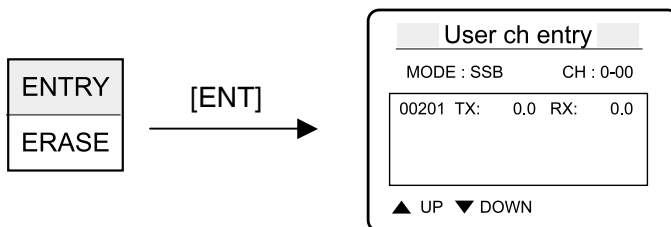

4. Press [ENT] to show “MODE, CH and FRQ” pop-up display. Set MODE, and enter a channel number and transmission/receiving frequencies.



The channel number is entered in four digits. The left digit(s) is a band (0 to 29) and the right 2 digits a channel number (01 to 99). For example, if 4567 kHz is registered to channel number 18, CH is “4-18”.

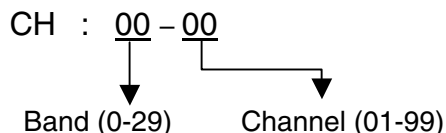

The following is the pop-up window which appears for frequency selection when creating a message file in “Message file entry” menu. The user channels are grouped into the same band. OTHER can contain four user channels of 0 band. Any frequency is set on the user channel of 0 band of which mode is DSC only.



3.2.2 Erasing all user channels

To erase all user channels;

1. Press [SETUP] in RT display.
2. Select “USER CH“ in RT SETUP menu and then press [ENT].
3. Select “ERASE” on “ENTRY/ERASE” pop-up display and press [ENT].

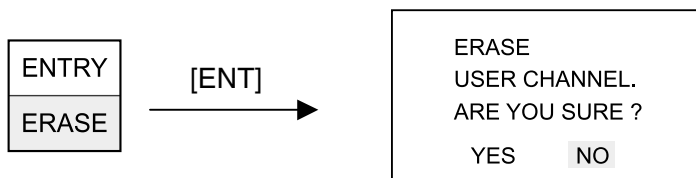

4. Select “YES” and then press [ENT].

3.2.3 Erasing user channel individually

To erase a user channel;

1. Press [SETUP] in RT display.
2. Select “USER CH” in RT SETUP menu and then press [ENT].
3. Select “ENTRY” in “ENTRY/ERASE” pop-up display and then press [ENT].

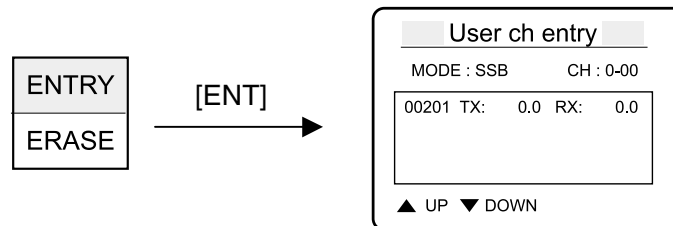

4. Press [ENT] to show “MODE, CH, FRQ” pop-up display.
5. Select the MODE and channel to be erased.
6. Set the transmission and receiving frequencies to 0.0 kHz.

3.3 DSC SETUP

The DSC is set up by using the following procedure.

1. Press [SETUP] in DSC display. “Setup menu” appears.

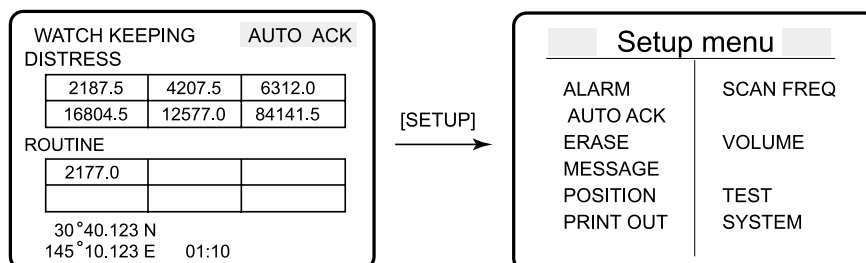

2. Select the item by the dial key. To open “SYSTEM” menu, a password is needed.
3. Press [ENT].
4. Select the value in the pop-up display by using the dial key.
5. To register the value entered, press [ENT].

To open “SYSTEM” menu

1. Move the cursor over “SYSTEM” and then press [ENT]. “System setup” appears with “PROTECTION ON” at the bottom.
2. Enter the password ([x][x][x][x][x][x]) to unlock “System setup” menu. The message in the bottom is changed to “PROTECTION OFF”.

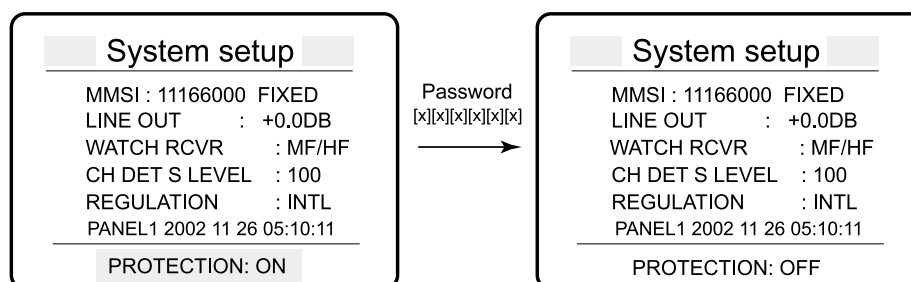

Table 3.3.1 lists the DSC SETUP Menus.

Table 3.3.1 DSC Set up menus

Item		Option						
1	ALARM	INTERNAL AUDIO ALARM	RCVD CALL	ON	OFF			
			OLD POSITION	ON	OFF			
		POSITION OLDER		4.0,	3.0,	2.0,	1.0,	0.5H
		EXT ALARM		DITRS/URG	ROUTINE	ALL	OFF	
2	AUTO ACK	COMPLY TYPE		UNABLE	ABLE			
		UNABLE REASON		See note)				
		POSITION CALL		ON	OFF			
		POLLING CALL		ON	OFF			
3	ERASE	RCVD ORDINARY LOG?		See page 3-18.				
		RCVD DISTRESS LOG?						
		TRANSMITTED LOG?						
		SEND MESSAGE?						
4	MESSAGE	Message file entry		See page 3-20.				
5	POSITION	INPUT TYPE		AUTO	MANUAL			
		LAT		Valid when INPUT TYPE is MANUAL.				
		LON						
		TIME						
6	PRINT OUT	XMIT CALL		AUTO	MANUAL			
		RCVD CALL		AUTO	MANUAL			
		DAILY TEST		AUTO	MANUAL			
7	SCAN FREQ.	ROUTIINE		F1-F6: OFF				
		DISTRESS		2,8M: FIXED 4,6,12,16M: ON				
8	VOLUME	KEY CLICK		ON	OFF			
		HANDSET		32		(0-63)		
		ORDINARY ALARM		35		(0-63)		
		DISTRESS ALARM		38		(38-63)		
9	TEST (PASSWORD)			See page 6-15.				
10	SYSTEM (PASSWORD)	MMSI		FIXED				
		LINE OUT		+0.0 DB	(-4.5 - +4.5dB		1.5dB step)	
		WATCH RCVR		MF/HF	MF			
		CH DET S LEVEL		100 (OFF – 255)				
		REGULATION		INTL	RUSSIA			

Note)

- 1) Factory-default is screened.
- 2) *: "UNABLE REASON" is selected among;
NO REASON GIVEN(default), BUSY, EQUIP DISABLE,
MODE NOT USABLE and CH NOT USABLE.

The following describes each item in DSC SETUP menu.

1. ALARM

Figure below is Alarm setup menu.

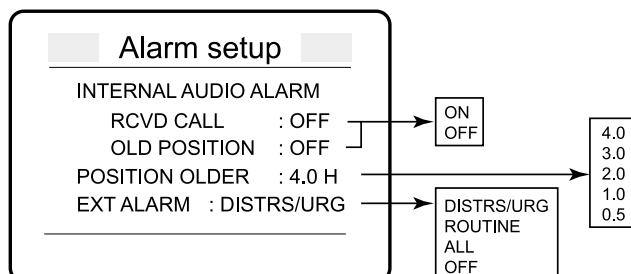

INTERNAL AUDIO ALARM

The alarm sound from the loudspeaker in FS-2570C is set to ON or OFF.

· RCVD CALL (ON/OFF)

The alarm is generated when the DSC message in Routine, Business and Safety categories is received. This alarm is set to ON or OFF.

At the reception of Distress and Urgency messages, the alarm sound is always generated regardless of the setting.

· OLD POSITION (ON/OFF)

When “POSITION“ entered manually in DSC SETUP menu is not updated within the preset time (“POSITION OLDER”) and when POSITION data from the sensor is not received, the alarm sounds. This alarm is set to on or off.

POSITION OLDER

The “Old position” alarm is triggered when the manual position is not updated within the preset time or “POSITION OLDER”. The options are 4.0, 3.0, 2.0, 1.0 and 0.5 hours. The manual position should be updated within 4 hours. The manual data is erased when it is not updated for 23.5 hours as required by the Res. MSC68(68). When the “Old position” alarm is triggered, the following message is displayed.

When the data is not updated:

Warning:
Update position

When EPFS data is not received for 1 minute or more:

EPFS error

EXT ALARM

The alarm sound from the incoming indicator (IC-303-DSC) is switched to ON or OFF according to the category of the DSC message. See table below.

Table 3.3.2 EXT ALM and category

Category	Options			
	DISTRS	ROUTINE	ALL	OFF
DISTRESS	ON	OFF	ON	OFF
URGENCY	ON	OFF	ON	OFF
SAFETY	OFF	OFF	ON	OFF
BUSINESS	OFF	ON	ON	OFF
ROUTINE	OFF	ON	ON	OFF

2. AUTO ACK

Figure below shows “Auto ack setup” menu.

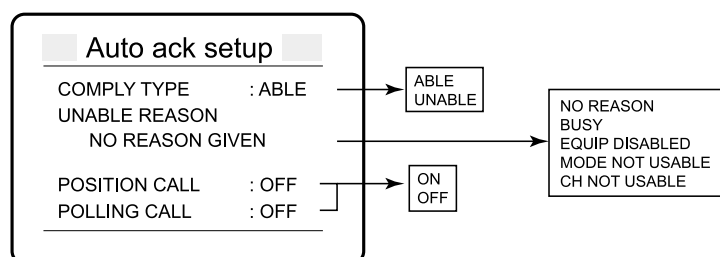
**COMPLY TYPE**

At the reception of Individual, PSTN, Position and Polling calls, acknowledgement can be sent out automatically with the selected comply type (able or unable). AUTO ACK is selected by using [ACK].

- ABLE: Able to comply
- UNABLE: Unable to comply

In Auto ACK mode, acknowledgement is not sent out automatically;

- When the received message includes an error (ECC ERROR).
- When the handset is “OFF HOOK”.
- When “COMPLY TYPE “ is “UNABLE” where as the setting of “POLLING” and “POSITION CALL” is ON.
- When the category is distress, urgent and safety.
- When the communication type is TTY, MORSE, FAX and DATA
- When the communication frequency is set to “No Information” or specified other than marine band.
- When either transmission or receiving frequency is not specified.

UNABLE REASON

This setting is valid when COMPLY TYPE is set to “UNABLE”. Selectable are; No reason, Busy, Equip disable, Mode not usable and CH not usable.

POSITION CALL

Position request call function is switched on or off. No ACK is sent when Comply Type is set to “unable”. See table 3.3.3.

POLLING CALL

Position call function is switched on or off. No ACK is sent when Comply Type is set to “unable”. See table 3.3.3.

Table 3.3.3 POSITION CALL and POLLING CALL settings

Setting		AUTO ACK		
		AUTO		MANUAL
		ABLE	UNABLE	
POSITION CALL	ON	Yes	No	No
	OFF	No	No	No
POLLING CALL	ON	Yes	No	No
	OFF	No	No	No

3. ERASE

Log files and Send message file in “Erase file” menu can be erased. Note that all files in the specified log type are erased. The next page describes how to erase the file individually.

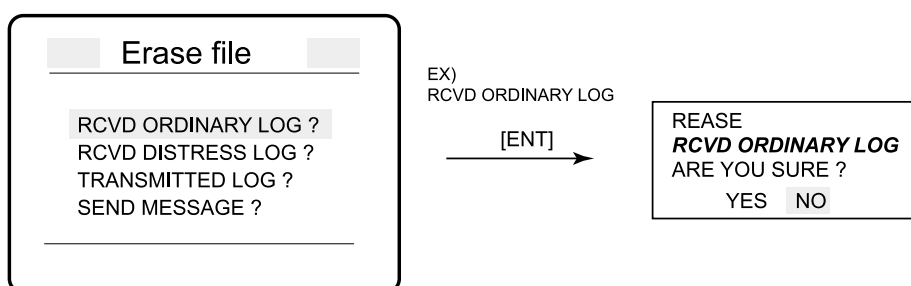
**To erase log files:**

1. Move the cursor over the desired log.
2. Press [ENT].
3. Select “yes” in the “Are you sure?” prompt.
4. Press [ENT].

Erasing log file individually

The log file can be erased individually by following steps below.

1. Press [0 LOG] in DSC Compose message and DSC SCAN displays to show “Select log file” display. “*” mark on “RECEIVED ORDINARY” line means there is the message not being acknowledged.

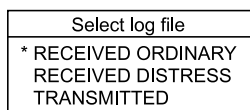

2. Select the file you want to open and press [ENT]. The messages in the file are listed.

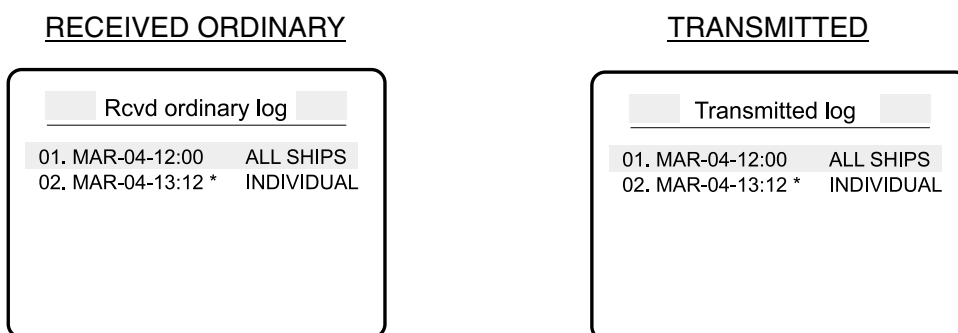

3. Select the message you want to erase and then press [ENT]. The pop-up display below appears.

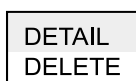

DETAIL: Shows the message in details
DELETE: Deletes the message

4. Select “DELETE” and then press [ENT] to erase the message.

Message marked by “*”

- 1) The message with no ACK BQ transmitted is marked by * in Received Ordinary log.
- 2) The message with no ACK BQ received is marked * in Transmitted log.

4. MESSAGE

A maximum of 150 messages can be created and reedited through this menu. A file is selected for transmission by using [*FILE]. The table below lists the creatable messages.

Table 3.3.4

Call type	Category	Communication type
INDIVIDUAL CALL	ROUTINE	TEL, ARQ, FEC-S
PSTN CALL	ROUTINE	—
GROUP CALL	ROUTINE	TEL, FEC-C
AREA CALL	ROUTINE	TEL, FEC-C
TEST CALL	SAFETY	—

Figure below shows “Message file entry” menus: the first page (left) and the second page (right). The “FILE NAME” is 16 character long. The “FILE NUMBER” is any number between 001 and 999 except 800 to 899.

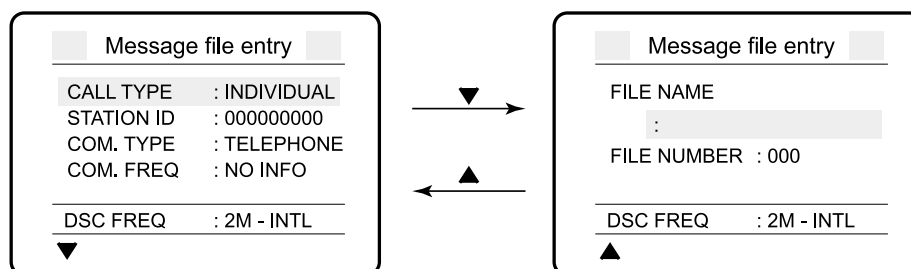

At the end of the message creation, the following prompt is displayed.

```

XXXX
NO. xxx file entered
Go to next file ?
    YES [ENT] KEY
    NO [CANCEL] KEY

```

If you enter a file number (name) that already exists, you will be prompted to overwrite that file.

```

Duplicate number(name) !
Overwrite OK ?
    YES [ENT] KEY
    NO [CANCEL] KEY

```

Note 1)

Table 3.3.5 lists the outline of the “Message file entry” for different call types.

Table 3.3.5 “Message file entry” Menu tree

Call Type	Item	Options	Data to be input
INDIVIDUAL	STATION ID	xxxxxxxxx	
	COM.TYPE	TELEPHONE	
		NBDP-ARQ	
		NBDP-FEC	
	COM.FREQ	NO INFO	
		FREQUENCY	TX: 12345.6 kHz RX: 12345.6 kHz
		CHANNEL	ITU/USER CH
		POSITION	Own ship position is displayed.
	DSC FREQ.	2 MHz	Select a DSC frequency from INTL and USER CH frequencies.
		4 MHz to 25 MHz	Select a DSC frequency from INTL, LOCAL-1, LOCAL-2 and USER CH frequencies.
OTHER			
PSTN	COST ID	00xxxxxxxx	Two leading zeros is entered automatically.
	TEL No.	xx—xxx (Max.16 digits)	
	DSC FREQ.	2 MHz	Select a DSC frequency from INTL and USER CH frequencies.
		4 MHz to 25 MHz	
OTHER			
GROUP	GROUP ID	0xxxxxxxx	One leading zero is entered automatically.
	COM.TYPE	TELEPHONE	
		NBDP-FEC-C	
	COM.FREQ	NO INFO	
		FREQUENCY	TX: 12345.6 kHz RX: 12345.6 kHz
		CHANNEL	ITU/USER CH
	DSC FREQ.	2 MHz	Select a DSC frequency from INTL and USER CH frequencies.
		4 MHz to 25 MHz	
OTHER			
AREA	AREA	N(S)/E(W), Area assignment	
	COM.TYPE	TELEPHONE	
		NBDP-FEC-C	
	COM.FREQ	NO INFO	
		FREQUENCY	TX: 12345.6 kHz RX: 12345.6 kHz
		CHANNEL	ITU/USER CH
	DSC FREQ.	2 MHz	Select a DSC frequency from INTL and USER CH frequencies.
		4 MHz to 25 MHz	
OTHER			
TEST CALL	COST ID		00xxxxxxxx
	DSC FREQ.	2187.5 to 16804.5	Select a 2 to 16 MHz distress/safety frequencies.

Note 2) When the registered message file is send.

1. Press [*FILE] key. The “Send message file” display appears.

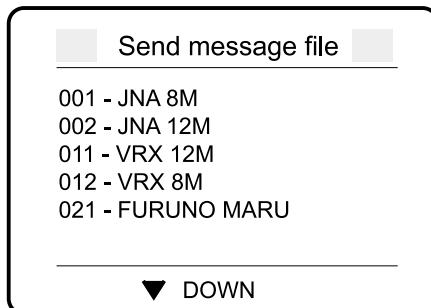

2. Select the file and then press [CALL]. The message is automatically send. When editing the message, press [ENT]. The popup below appears. Select “DETAIL” and then press [ENT].



After editing the registered message, press [CALL] to sent.

Note 3) When the registered message file is deleted individually.

1. Press [*FILE] key. The “Send message file” display appears.
2. Select the file you want to delete and then press [ENT]. The popup below appears. Select “DELETE” and the press [ENT]. The registered message is deleted from the list.

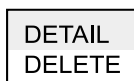

5. POSITION

When position data is received from EPFS, INPUT TYPE is set to AUTO. The receivable IEC-61162-1 and NMEA (Ver-2.0 or above) sentences are GGA>RMC>GLL (position) and ZDA (time).

The position data input by MANUAL setting has higher priority than the one input by AUTO setting.

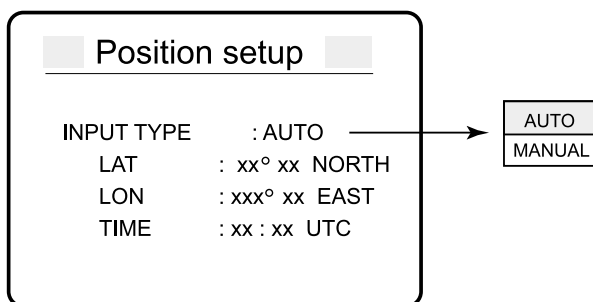

“Invalid” position data is not received.

The position data is used in Distress, Individual and Position Call messages. The data is automatically erased and “Warning: Update position” message appears when it is not updated for 23.5 hours. EPFS error message is displayed and the alarm sound is released when EPFS data is interrupted for one minute.

DIP switch Setting

The DIP switch S2 on T-CPU board sets the interface type to either RS-422 or current loop.

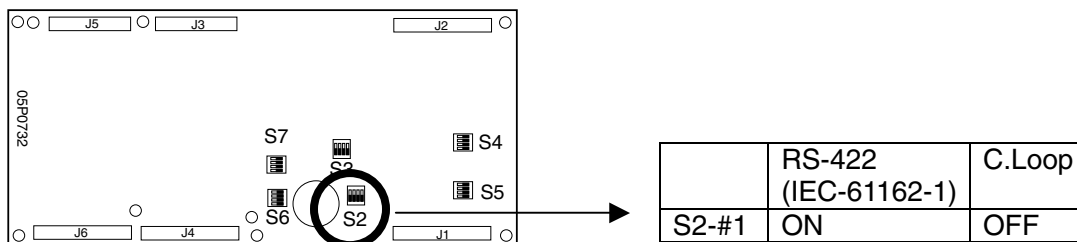

Time data

Table 3.3.6 lists times displayed and printed out in conjunction with the source of time data.

Table 3.3.6 Time data

Times displayed and printed	Data to be used (source)	Remarks
Time in DSC display	Time included in position data	
Time in DSC self-test result display	Real Time Clock (RTC) on T-CPU board	The real time clock on T-CPU board is reset by ZDA at power on.
Time stamp on DSC self-test result		
Time stamp on communication log file		
Time stamp at transmission		
Time stamp at reception		
Time on IB-581	RTC from FS-1570/2570	RTC on IB-583/581 is reset by RTC from FS-1570/2570 every time IB-583/581 is turned on.
Time on IB-583		

6. PRINT OUT

The automatic printing mode is switched on or off. Transmitted message, received message and test result are printed out. To print out the messages and test result manually, press [8 Print].

XMTD CALL

Automatic printing of transmitted DSC message is switched on or off.

RCVD CALL

Automatic printing of received DSC message is switched on or off.

DAILY TEST

Automatic printing of daily test result is switched on or off.

7. SCAN FREQ.

DSC distress and safety frequency (Distress) and routine frequency (Routine) are set for scanning. The ship navigating in sea areas A3/A4 must maintain a continuous DSC watch on 2187.5 kHz, 8414.5 kHz and one other HF watch keeping frequency. In sea area A2, the DSC watch keeping frequency is 2187.5 kHz only.

When the DSC watch keeping receiver is defective, the watch keeping frequencies is set in the Routine scan table.

DSC distress/safety frequency according to the sea areas is set by MF/HF setting of the WATCH RCVR in DSC SYSTEM Setup menu. See page 3-27.

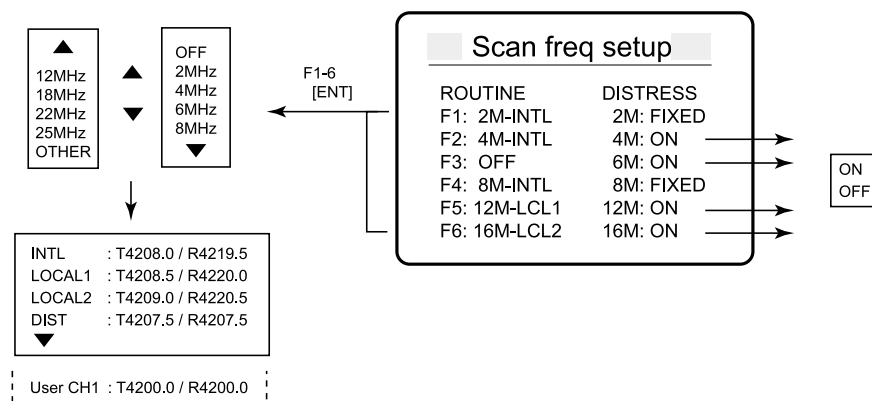

- In Distress scan table, 2MHz and 8MHz are kept being ON. Among the remained frequencies, three frequencies can be turned off.
- The user channel used in Routine scan table is entered through “RT SETUP” menu. OTHER includes the user channels of “0” band.

8. VOLUME

Following display appear when VOLUME is selected in DSC SETUP menu.

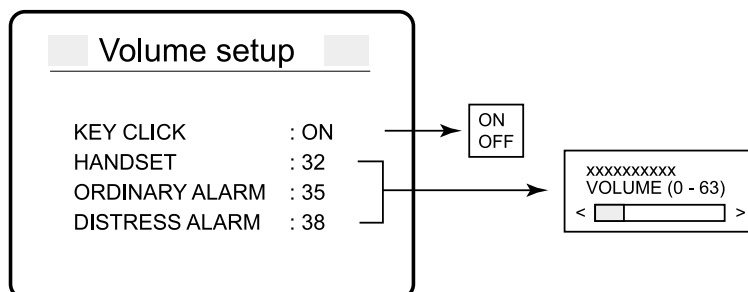

KEY CLICK

Key click is set to ON or OFF.

HANDSET

Adjusts the volume of the loudspeaker on the handset (0 to 63).

ORDINARY ALARM

Adjusts the volume of the alarm sound which is released when the message in Safety, Business and Routine categories is received (0 to 63).

DISTRESS ALARM

Adjusts the volume of the alarm sound which is released when the message in Distress and Urgency categories is received (38 to 63).

9. TEST

See Chapter 6, page 6-15.

10. SYSTEM

To unlock the system menu, move the cursor over "PROTECTION ON" and then enter the password ([x][x][x][x][x][x]).

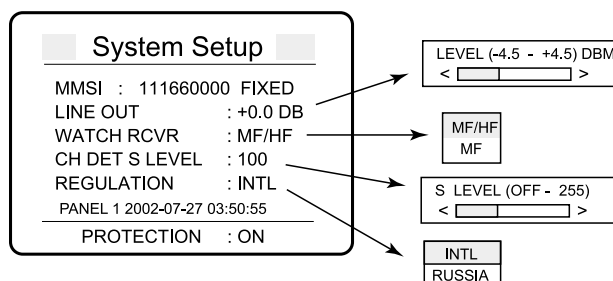

The system menu contains the following items.

MMSI (FIXED)

The registered MMIS is displayed. See page 3-1 for how to register MMSI.

LINE OUT (+0 DB)

Adjusts the output level of the modem on DSC and NBDP DSP boards in 1.5 dB steps. **Leave the setting as default.**

WATCH RCVR (MF/HF, MF)

The watch receiver is set to "MF/HF" for the ship navigating in sea areas A3/A4 or "MF" for the ship navigating in sea area A2. When the receiver is set to MF/HF, up to 6 DSC watch keeping frequencies are programmed. When the MF is selected, the frequency is solely 2187.5 kHz.

CH DET S LEVEL (OFF - 255)

Before transmitting Routine and Business messages, the system automatically monitors the channel to ensure that it is free. If the signal level is stronger than CH DET S LEVEL, CH BUSY appears at the lower left of the display, indicating that the channel is in use.

The preset volume of 100 is the same level as S-meter reading of 4. The maximum reading of the S-meter is equal to 255. To switch off the channel monitor function, set CH DET S LEVEL to OFF. Forced transmission is made by using [CALL]. During channel monitoring, AGC is set to FAST automatically.

REGULATION (INTL, RUSSIA)

The DSC is set up in accordance with International or Russian regulation.

The differences between INTL (International) and RUSSIA are;

1) Distress alarm after the distress message is sent

INTL: The alarm sound stops.

RUSSIA: The alarm continues to sound.

2) Function of [CANCEL] key during distress alert call

INTL: Pressing [CANCEL] does not cancel the distress alert call or the sequence is repeated.

RUSSIA: Pressing [CANCEL] cancels the distress alert call after the sequence is completed.

3) Reception of distress alert and urgency message

INTL: Sending a DSC call has priority over receiving DSC distress and urgency calls. The received DSC message is printed out and logged during the transmission of the DSC message.

RUSSIA: When another distress alert or urgency message is received just after [CALL] is pressed to acknowledge a distress alert and for distress alert relay, the display shows the received message, canceling the transmission sequence of acknowledgement and relay.

“PANEL 1 2002-07-27 03:50:55”

This indication means that the distress alert was made at 03 hours 50 minutes 55 seconds on 27 July 2002 from No.1 controller.

When the distress alert is made from No.2 controller, the head of the message is changed from “PANEL 1” to “PANEL 2”. When the distress alert is made from DMC-5, the head of the message is changed from “PANEL 1” to “DMC”.

3.4 DIP Switch

Fig.3.4.1 shows the DIP switch on T-CPU board. Table 3.4.1 lists the function and the default of the DIP switch.

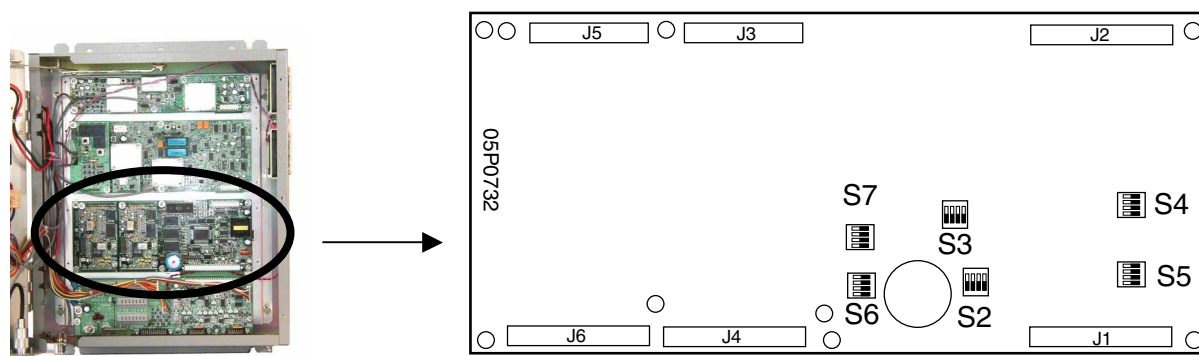

Fig.3.4.1 DIP switch on T-CPU board

Table 3.4.1 Function of DIP switch

SW	Function	Default Setting			
		#1	#2	#3	#4
S2	Selection of RX data type (RS-422 or Current Loop)	OFF (Position)	OFF (DMC)	OFF (MIF)	OFF (N.C)
S3	Selection of MIF data type (RS-232C or RS-422)	OFF	OFF	ON	ON
S4	Selection of incoming indicator type	ON	ON	ON	ON
S5	(IC-303-DSC or IC-xxx)	OFF	OFF	OFF	OFF
S6	Selection of distress alert button type	ON	ON	ON	ON
S7	(DMC-5 or IC-302-DSC)	OFF	OFF	OFF	OFF

1. Receiving Position data

Either RS-422 or C.Loop signal can be received with the different setting of S2-#1. The system does not support CIF format. When S2-#1 is set to ON, R60 short circuits to receive RS-422 signal. IEC TX circuit (#22 and #23 pins) is not used.

DIP SW	Spec	RX DATA	
		RS-422	C. Loop
S2-#1		ON	OFF

* The default is screened.

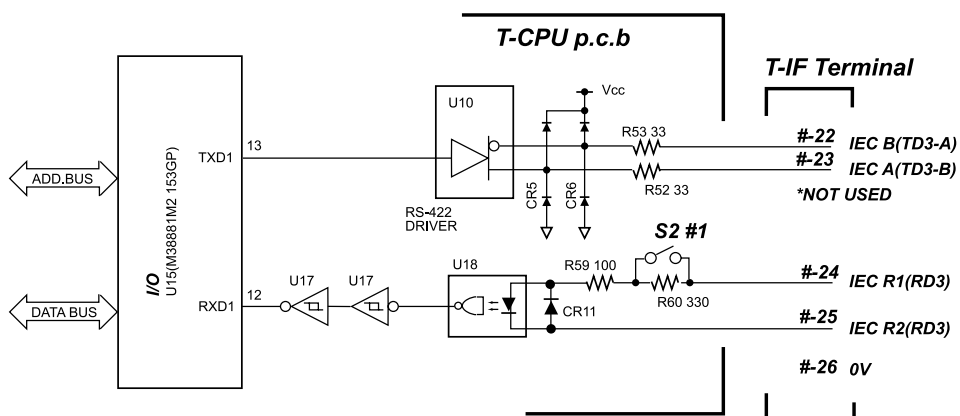

- Position data sentence (IEC-61162-1): GGA>RMC>GLL
- Date and time data sentence: ZDA

2. Connecting Distress Alert Button

Neither DMC-5 nor IC-302-DSC can be connected with the following setting of the switches on T-CPU board.

DMC-5: S2-#2: OFF; S6: All ON and S7: All OFF

IC-302-DSC: S6: All OFF and S7: All ON

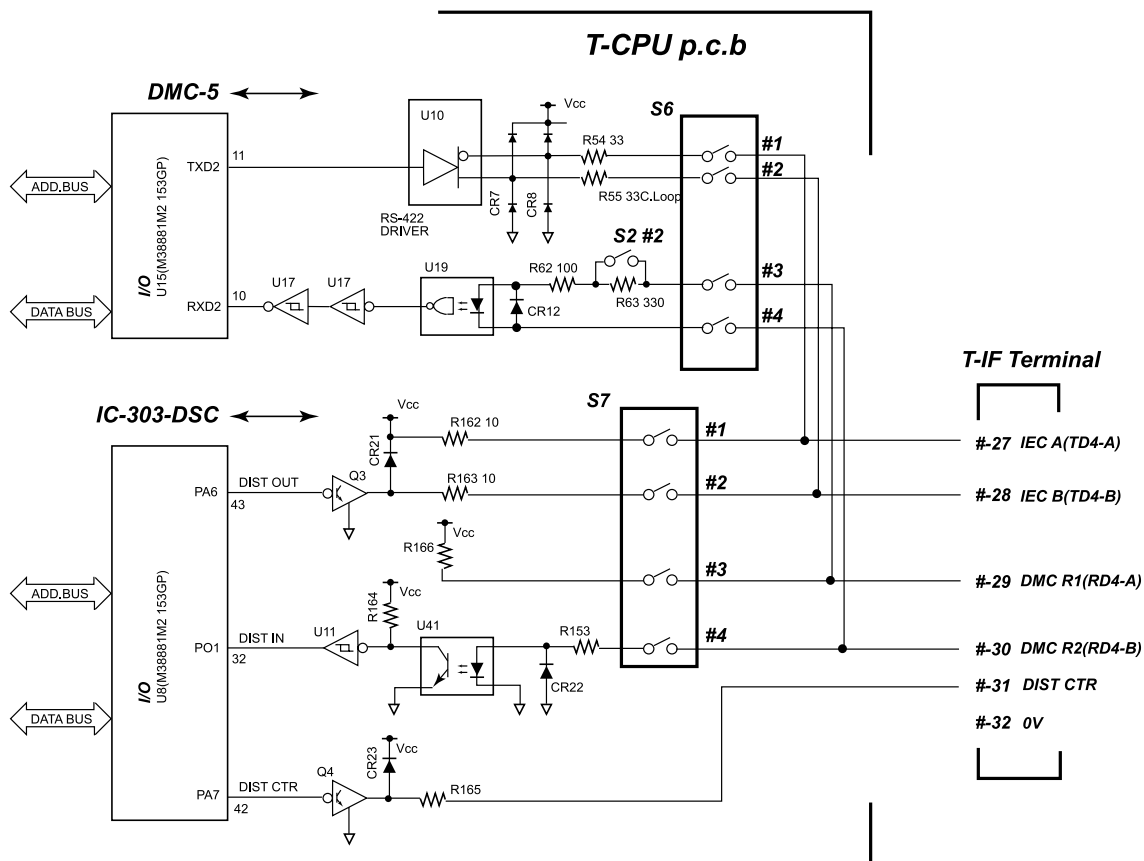

3. Connecting Incoming Indicator

Incoming indicator, IC-303-DSC or IC-xxx(for future) can be connected. Select the output circuit desired by using S4 and S5.

When IC-303-DSC is connected; S4: All ON and S5: All OFF.

When IC-xxx is connected; S4: All OFF and S5: All ON.

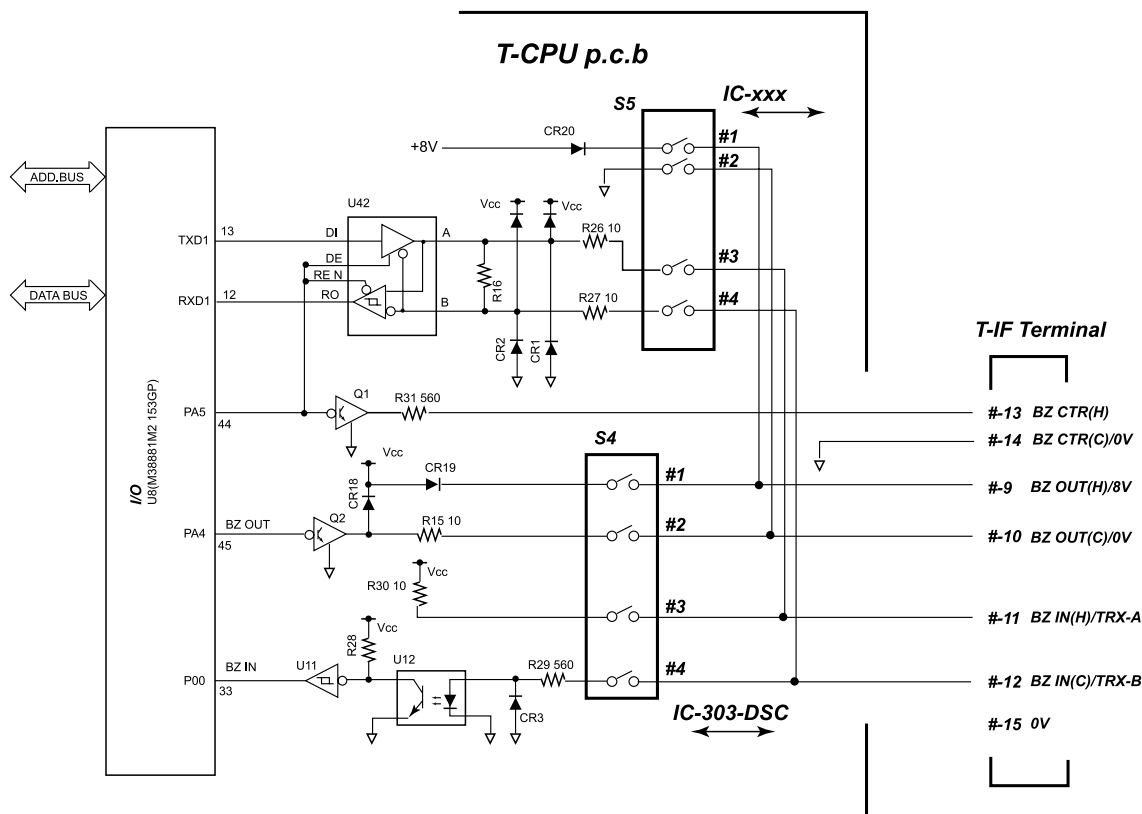

4. Connecting PC

The system can be controlled with the PC connected to “REMOTE” terminal, D-Sub 25P. Depending on the data type from the PC, S2 and S3 is set to as below. Note that pin numbers to be used are different between data types.

Data	Port	S2	S3			
		#3	#1	#2	#3	#4
RS-232C	MIF SD MIF RD	ON or OFF	OFF	OFF	ON	ON
RS-422	MIF A MIF B MIF R1 MIF R2	ON	ON	ON	OFF	OFF

* The default is screened.

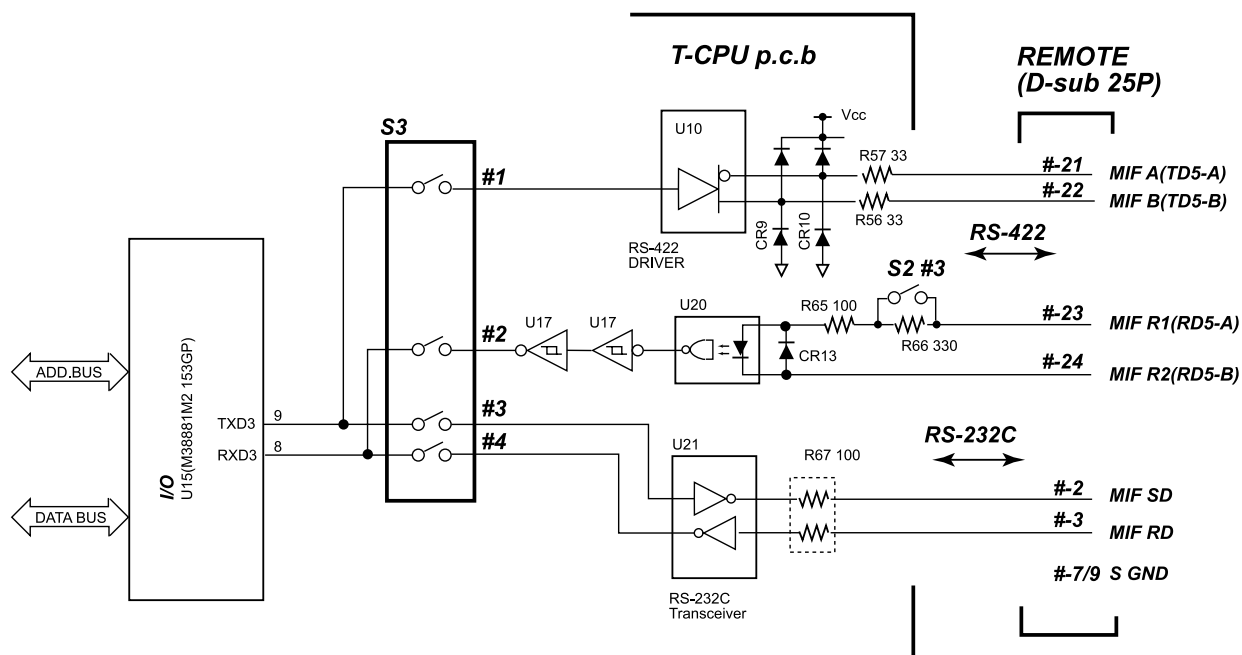

3.5 Jumper

3.5.1 When FAX-5 is used for W/R

When the antenna preamplifier, FAX-5 is used for receiving DSC signal, the jumper plug J3 on W/R board, 05P0734 is placed between #1 and #2.

The FAX-5 needs +12 V power supply. The default of J3 is #2/#3 and +12 V is not supplied to the antenna connector.

W/R board for DSC general frequencies (Option)

W/R board for DSC distress/safety frequencies

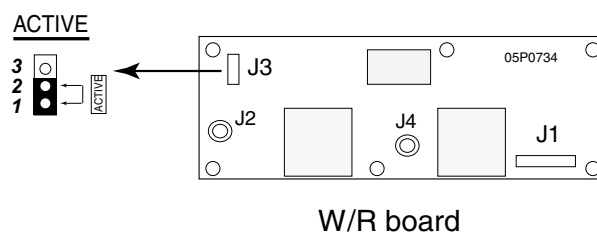
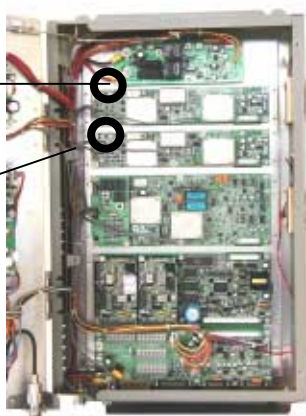

Optional W/R board is available for FS-2570, (not for FS-1570) to receive DSC general frequencies.

To install DSC general frequencies receiver board;

Connect J7 (REF OUT) on TX/RX board to J4 (REF IN) on W/R board by the coaxial cable supplied.

Mount W/R boards here.

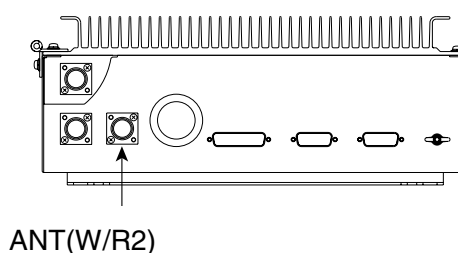
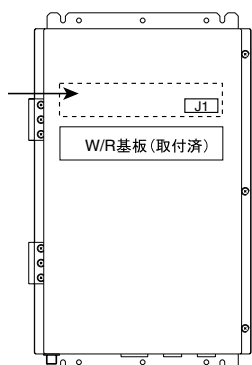

3.5.2 When TR antenna is used for W/R

Optional W/R board can be connected to TR antenna with the following changes.

- 1) JP1: Short
- 2) JP2: Open
- 3) Change the connection from J3 to J10.
- 4) Connect J2 on W/R board to J9 on TX FIL board. J9 and J10 are connected in parallel.

TX-FIL board

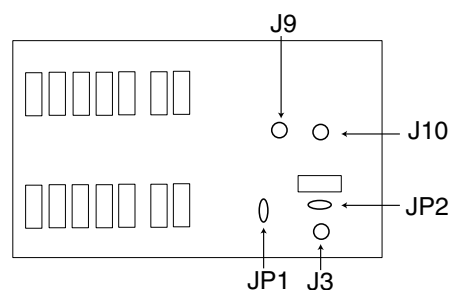
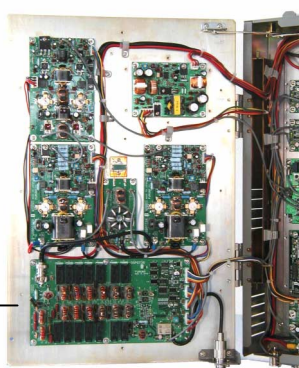

TX-FIL board

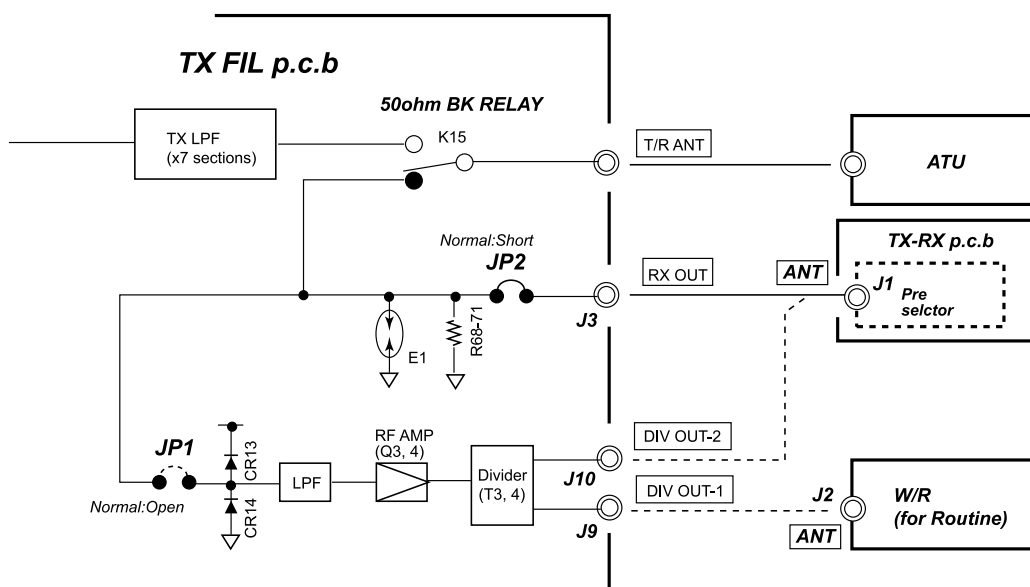

The DSC distress and safety frequencies receiver should have own antenna.

3.6 Installing DSP board for NBDP

For NBDP communication, DSP board (05P0751, Code No. 005-952-020) is needed optionally. DSP board is mounted onto T-CPU board. DSP boards for DSC and NBDP are the same in hardware, but different in software.

DSP board for NBDP

DSP board for DSC

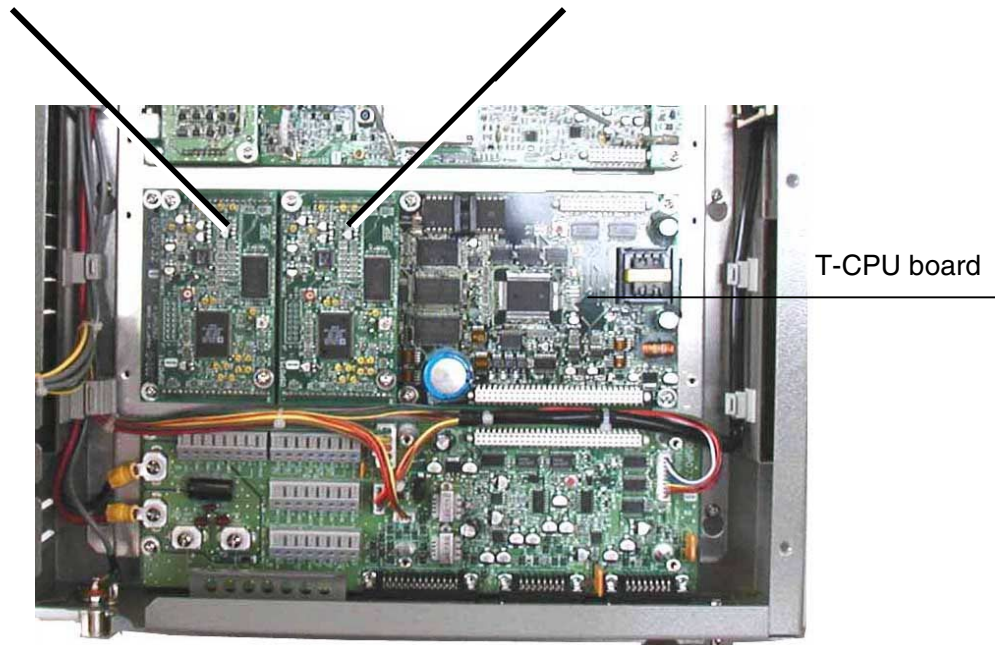

3.7 IB-581/IB-583

The table 3.7.1 shows the necessary settings on the NBDP terminal, IB-581/583.

Table 3.7.1 Settings on IB-581/583 List

	Item	Default	Option	Remarks
Operate (F3)	6. Manual Reception	AUTO	AUTO ARQ FEC DIRCT	
Station (F5)	5. Answerback Code Entry	—	MMSI+CS (4digit)+X	Password: ANSWER CODE
	6. Group ID Entry (4/5 digit)	—		Password: ID CODE
	7. Group ID Entry (9 digit)	—		
	8. Select ID Entry (4/5 digit)	—	Sell call number	
	9. Select ID Entry (9 digit)	—	MMSI	
System (F6)	Slave Delay	8 msec	0 - 50 msec	Leave the setting as default. Password: DP6
	TX/RX MSG Save	OFF	ON or OFF	
	Edit before sending	OFF	ON or OFF	
	Time System	UTC	OFF,UTC,SMT,JST	
	Time & Date			The RTC is reset by the date and time data from the RT unit every time the IB-583/581 is turned on.
	Display Mode**	Normal	Normal, Reverses	Only IB-581 appear
	Window color**	—	Window color setup Default	Only IB-583 appear
Fn+F1	Language	Normal	Normal,Nolway,Sweden,UK	Password: DP6
	Printer	PP-510	PP-510,OTHER	

3.7.1 Manual Reception menu (F3, 6)

Confirm that Manual Reception is set to AUTO. Keystrokes:[F3], [6].

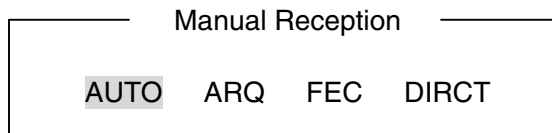

- AUTO: Receiving the messages in ARQ and FEC mode automatically
- ARQ: Receiving the message in ARQ mode only
- FEC: Receiving the message in FEC mode only
- DIRCT: Receiving the message in DIRCT mode only

The setting of Manual Reception is displayed on “Comm. Mode“ line in the status display of the terminal unit. Indication AUTO changes to ARQ, CFEC (Collective FEC) and SFEC (Selective FEC) depending on the operation mode.

3.7.2 Station menu (F5)

Pressing [F5] shows the station menu below.

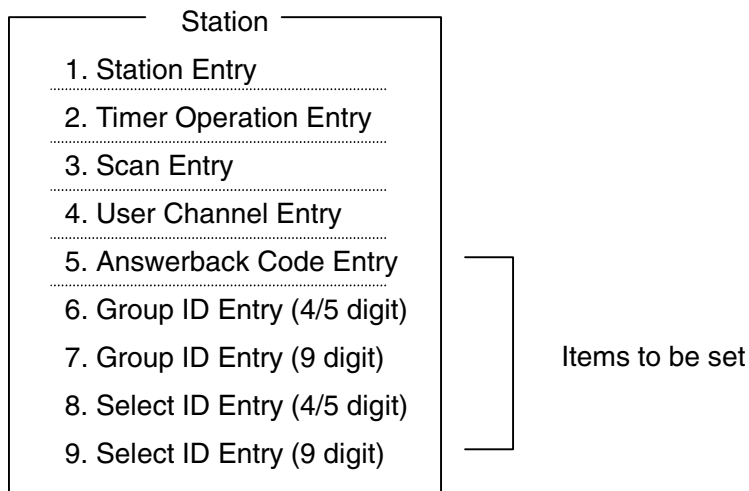

1. Registering Answerback

The Answerback code is entered by following the procedure below. The answerback code consists of MMSI number, 4 letters and X. For example, the MMSI is 431456789, ship name FURUNO and call sign JAAA, the answerback code is 431456789 FURU X or 431456789 JAAA X. 4 letters are the call sign or one you filled out in the Inmarsat registration sheet. The answerback code of the marine mobile station ends with X.

Procedure

1. Select “5. Answerback Code Entry” and type the answerback code.

Answerback Code Entry Answerback Code Entry 431456789 FURU X
--

2. Press [ENT] and “OK/Cancel” prompt is displayed. Select “OK” and then press [ENT].

Answerback Code Entry Answerback Code Entry 431456789 FURU X	<table border="1"> <tr> <td>OK</td> </tr> <tr> <td>Cancel</td> </tr> </table>	OK	Cancel
OK			
Cancel			

3. With the confirmation message, press [ENT].

Caution Confirm the “CODE” before pressing ENTER key. You cannot change the CODE once it has been entered.

Re-registering answerback code

First, delete the answerback code by typing “ANSWER (space) CODE” in capital letters with “5. Answerback Code Entry” display. Then enter new answerback code.

2. Registering ID number

The identification number is entered by using “8. Select ID Entry (4/5 digit)” or “9. Select ID Entry (9 digit)” depending on the digit number of the ID. If Group ID is assigned to the ship, use “6. Group ID Entry (4/5 digit)” or “7. Group ID Entry (9 digit)”.

Procedure

For example, to enter ID of 431456789;

1. Select “9. Select ID Entry (9 digit)” and type the number.

Select ID Entry Select ID Code (9) 431456789
--

2. Press [ENT] and ”OK/Cancel” prompt is displayed. Select “OK” and then press [ENT].

Select ID Entry Select ID Code (9) 431456789	<table border="1"> <tr> <td>OK</td> </tr> <tr> <td>Cancel</td> </tr> </table>	OK	Cancel
OK			
Cancel			

3. With confirmation message, press [ENT].

Caution Confirm the “CODE” before pressing ENTER key. You cannot change the CODE once it has been entered.

Re-registering ID number

First, delete the ID number by typing “**ID (space) CODE**” in capital letters with the ID entry menu (6:Group ID entry to 9:Select ID entry). Then enter new ID number.

3.7.3 System menu (F6)

Pressing [F6] displays System menu. Setting “Slave Delay” and move the cursor to [Default] needs to enter password.

Enter password;

1. Press [F6] to show “System” menu.
2. Enter password “**DP6**” in capital letters.

Then;

To change the settings;

1. Move the cursor to [Change].
2. Then, select the item.

To reset setting to factory default;

1. Move the cursor to [Default].
2. Then, press [ENT].

System		
Setup	Lock	Change Default

Slave Delay	8 msec	(0 - 50 msec)

TX/RX MSG Save	OFF	ON
Edit Before sending	OFF	ON

Time System	OFF	UTC STM JST
Time & Date	2002/ 7/ 1/10:00:00	
(Display Mode*)	Normal	Reverse
(Window color*)		
Self Test		

→ IB-581

→ IB-583

Slave Delay

When operating in ARQ mode, the called station employs a constant time interval between the end of the received signal and the start of the transmitted signal.

Leave the setting as default. “8 msec”

TX/RX MSG Save (OFF)

This setting decides whether received messages are automatically saved in FDD, or not.

Edit before sending (OFF)

At the real time communication;

- 1) A character is sent out each time it is typed when set to OFF.
- 2) Characters are sent out at the time [ENT] is pressed when set to ON.

Time System

The time system is selected to UTC (Universal Time Coordinated), SMT (Ship Mean Time) or JST (Japan Standard Time). When set "OFF", time is not displayed.

Time & Date

The RTC is reset by the date and time data from the transceiver unit every time the IB-583/581 is turned on. Normally, setting of this line is not necessary.

*Display Mode (IB-581)

In "Reveres" mode, black and white are reversed on the display.

*Window color (IB-583)

Window color is set by "Window color setup". See the table below. When the setting value is changed to the default, select "2. Default".

Window	Fore color	Back color
Base window	Black	White
Back scroll	Green	Gray
Edit-1	Cyan	L-Blue
Edit-2	Red	L-Green
Function	Magenta	L-Cyan
Sub menu-1	Brown	L-Red
Sub menu-2	White	L-Magenta
Sub menu-3	Gray	L-White
Sub menu-4	L-Blue	Yellow
Message	L-Green	Blue
	L-Cyan	Green
	L-Red	Cyan
	L-Magenta	Red
	L-White	Magenta
	Yellow	Brown

3.7.4 Printer and language setting

Press [F1] while holding [Fn] to show “Set up” display for language and printer. Enter the password **DP6** in capital letter to unlock the menu.

Set up			
Language	<u>Normal</u>	Norway	Sweden UK
Printer	<u>PP-510</u>	OTHER	

Language setting programs local characters onto the following keys.

<i>Key</i> <i>Language</i>	[; \]	[]]]	[[[]
Normal	—	—	—
Norway	φ	Å / å	Æ / æ
Sweden	Ö / ö	Å / å	Ä / ä
UK	£	—	@

Brightness Adjustment on IB-583

Press [F6] while holding [Alt] to decrease the brightness of the display at 8 levels. To increase the brightness, press [F7] while holding [Alt].

IB-583/IB-581 Menu List

Table 3.7.2 lists the IB-583/IB-581 Menu list.

Table 3.7.2 NBDP terminal menu

F1: File	F2: Edit	F3: Operate	F4: Window	F5: Station	F6: System
1. New	1. Undo	1. Call Station	1. Calendar	1. Station Entry	Slave Delay
2. Open	2. Cut	2. Macro Operation	2. Distress Frequency Table	2. Timer Operation Entry	TX/RX MSG Save
3. Close	3. Copy	3. File to Send		3. Scan Entry	Edit Before sending
4. Delete	4. Paste	4. Cancel Sending		4. User Channel Entry	Time System
5. Rename	5. Select All	5. Scan (Start/Stop)		5. Answerback Code Entry	Time & Date
6. Real Time Printing	6. Search	6. Manual Reception		6. Group ID Entry (4/5 digit)	Display Mode* (IB-581)
7. File to Print	7. Replace	7. Timer Operation		7. Group ID Entry (9 digit)	Window color* (IB-583)
8. Cancel Printing	8. Go to Top	8. Manual Calling		8. Select ID Entry (4/5 digit)	Self Test
9. Clear Buffer	9. Go to Bottom	9. Set Frequency		9. Select ID Entry (9 digit)	
0.Floppy Disk Format	0. Go to Line				
	A.Change Text				

Chapter 4. Updating program

4.1 General

Table 4.1.1 shows the programs used by the radiotelephone.

Table 4.1.1 Program

Program	Program number	Remarks
T-CPU	0550205-01.xx	FS-1570T (2570T) program
C-CPU	0550206-01.xx	FS-2570C program
DSC MODEM	0550207-01.xx	MODEM program for DSC
NBDP MODEM	0550208-01.xx	MODEM program for NBDP
TERMINAL (IB-583)	0550209-22.xx	NBDP terminal program for FS-1570/FS-2570
TERMINAL (IB-581)	0550210-22.xx	NBDP terminal program for FS-1570/FS-2570

The program is updated by clicking the batch file icon or entering the batch command in the DOS window.

Table 4.1.2 Program updating

Program	Port to be used		Command	Updating time	Updating speed
C-CPU	FS-2570C	[NBDP] port	UPCONT.BAT	6 min.	38.4 kbps
T-CPU	FS-1570T FS-2570T	[REMOTE] port	UPTRX.BAT	4 min.	
DSC MODEM			UPDSC.BAT	1 min.	
NBDP MODEM			UPNBDP.BAT	1 min.	
TERMINAL* (IB-583)	IB-583	[DTE] port or FDD (depend on boot program)	UP583.BAT	1 min.	57.6 kbps
TERMINAL (IB-581)	IB-581	FDD	UP581E.BAT** (English)	1 min.	-
			UP581R.BAT** (Russian)	1 min.	

*: To change the language of IB-583:

English version: Turn power on while pressing [E]

Russian version: Turn power on while pressing [R]

** : To install from the system file of IB-581:

English version: Type "INSTALL"

Russian version: Type "RUSINST"

4.2 Connection

A PC is connected to a different port for program updating depending on the program to be updated.

4.2.1 C-CPU

Connect the PC to “NBDP” port on FS-2570C as below. FS-2570C is connected to “CONTROLLER-1” port on FS-1570T/2570T. To update No.2 controller FS-2570C, change the connection for “CONTROLLER-2” port to “CONTROLLER-1” port.

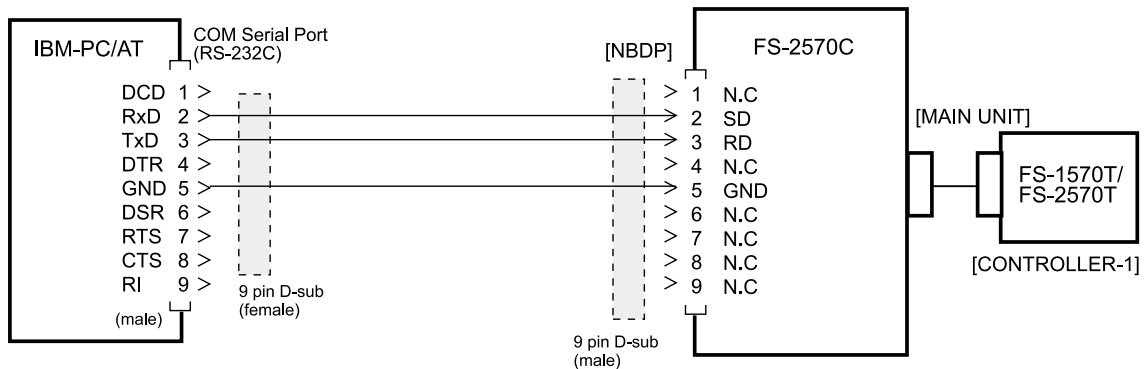

Fig.4.2.1 Wiring between FS-2570C and PC

4.2.2 T-CPU, DSC MODEM and NBDP MODEM

Connect the PC to “REMOTE” port as below. FS-2570C is connected to “CONTROLLER-1” port.

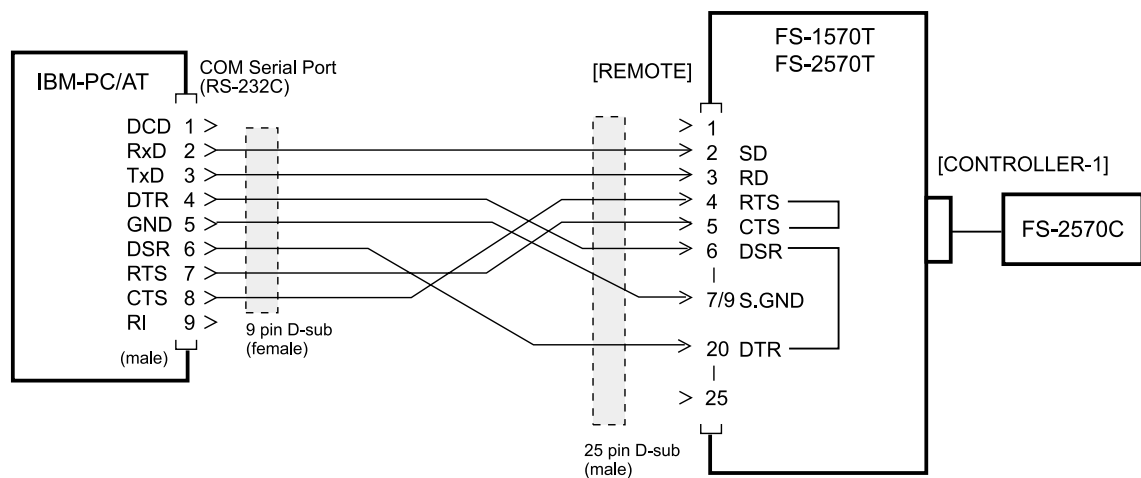

Fig. 4.2.2 Wiring between FS-1570T/FS-2570T and PC

4.2.3 IB-583

IB-583 is updated individually. Connect the PC to DTE port.

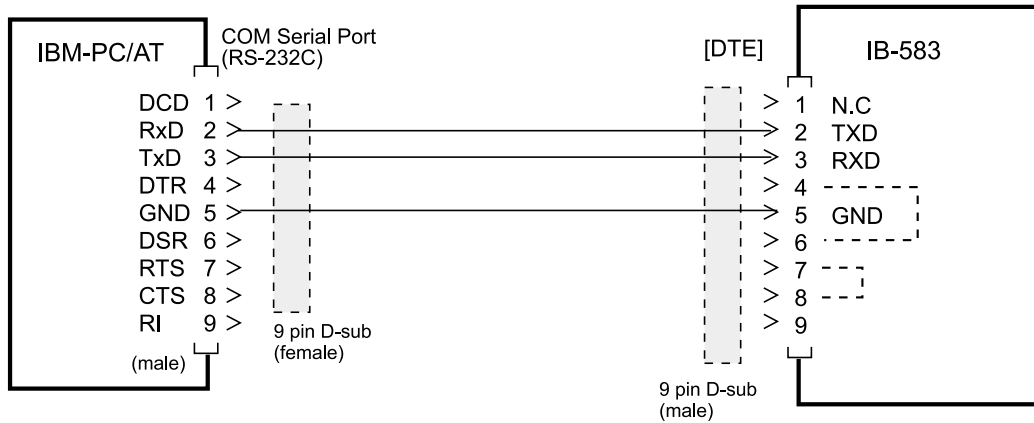

Fig.4.2.3 Wiring between IB-583 and PC

4.3 DIP Switch Setting

When the following program is updated, DIP switches S3-#3 and #4 are set to ON, S3-#1 and #2 OFF on T-CPU board

Program: T-CPU, DSC MODEM and NBDP MODEM

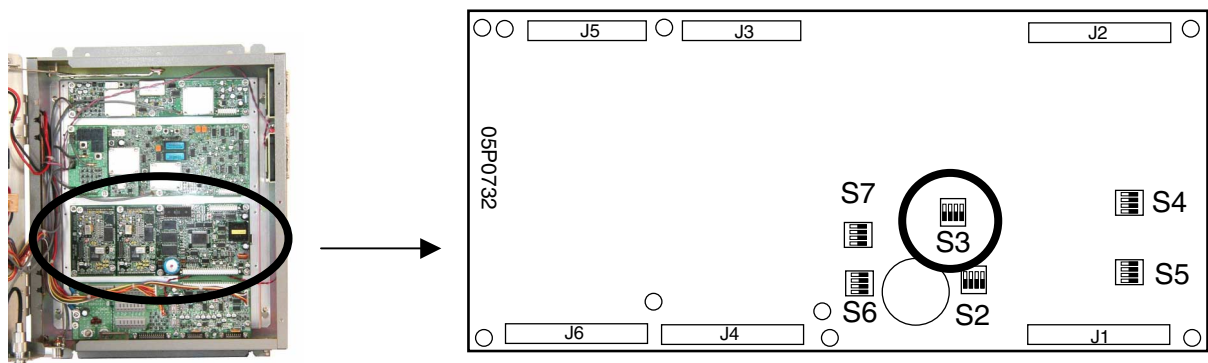

Fig.4.3.1 DIP switch S3 on T-CPU board

4.4 Updating Program

The followings show how to update each program.

4.4.1 T-CPU and C-CPU

To update the program;

1. Turn off the system. FS-1570/FS-2570
2. Connect the PC. See 4.2 Connection.
3. Confirm that DIP switch S3-#3 and #4 is ON and S3-#1 and #2 is OFF on T-CPU board when T-CPU program is updated.
4. Insert the floppy disk which contains the latest program into the drive A.
5. Double click the batch file icon of the program to be updated.
When updating by using DOS window, enter the batch file name to be updated.

Program to be updated	Command
C-CPU	UPCONT.BAT
T-CPU	UPTRX.BAT

6. Updating program runs automatically.

```

UPPG
自動
A: ¥>
A: ¥>cd cont
A: ¥cont>uppg main.cfg
[ PORT STATE ]
[ Loader File   ]: loader.bin
[ Hex   File   ]: fs1570pn.bin
[   Version   ]: VOL 2001/12/14-21:30
< Upg Start! >:
[ PORT OPEN   ]: OPEN Port 1 OK!
[ PORT PROPATY]: SET Port1 OK!
[Waitting For Target Wake up.... ] Time :  8 (sec)_
  
```

7. When the message “[Waiting For Target Wake up ...] Time : x (sec)” appears, turn on the system within 25 seconds. If the message “Time Out Error !” appears, close the display by pressing [C] while holding down [Ctrl], and repeat from step 5.

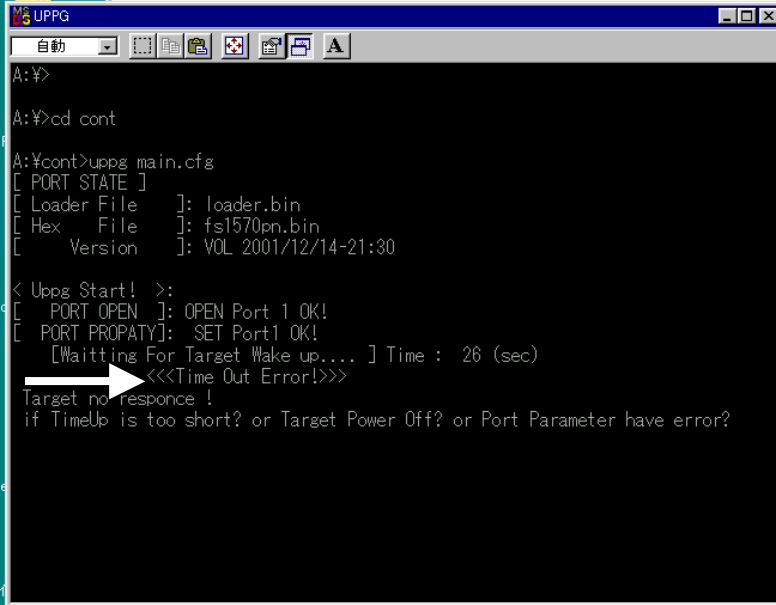

```

UPPG
自動
A:¥>
A:¥>cd cont
A:¥cont>uppg main.cfg
[ PORT STATE ]
[ Loader File   ]: loader.bin
[ Hex   File   ]: fs1570pn.bin
[      Version  ]: VOL 2001/12/14-21:30

< Uppg Start! >:
[ PORT OPEN   ]: OPEN Port 1 OK!
[ PORT PROPATY]: SET Port1 OK!
[Waiting For Target Wake up.... ] Time : 26 (sec)
<<<Time Out Error!>>>
Target no responce !
if TimeUp is too short? or Target Power Off? or Port Parameter have error?
  
```

8. The PC display changes as below.
You can see the message;
“LOAD CONFIG DATA FROM TRX UNIT” on FS-2570C during TRXUP,
nothing appears on FS-2570C during CONTUP.

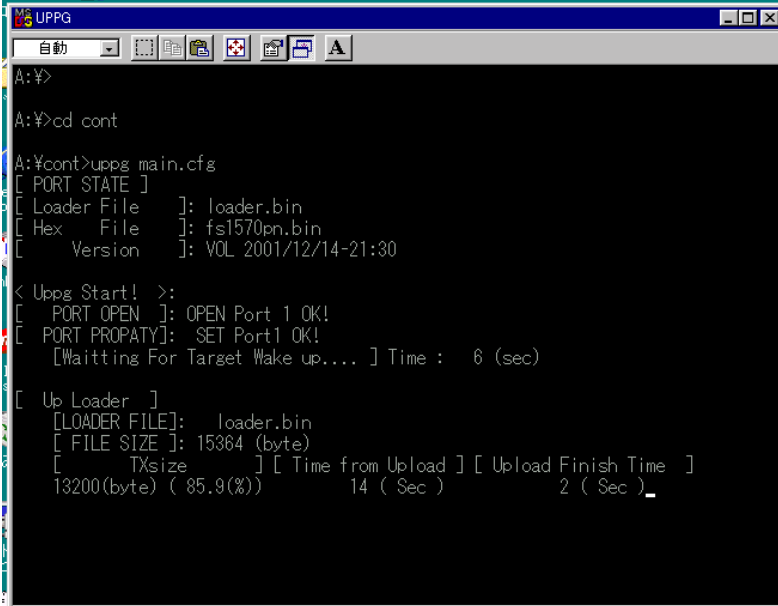

```

UPPG
自動
A:¥>
A:¥>cd cont
A:¥cont>uppg main.cfg
[ PORT STATE ]
[ Loader File   ]: loader.bin
[ Hex   File   ]: fs1570pn.bin
[      Version  ]: VOL 2001/12/14-21:30

< Uppg Start! >:
[ PORT OPEN   ]: OPEN Port 1 OK!
[ PORT PROPATY]: SET Port1 OK!
[Waiting For Target Wake up.... ] Time : 6 (sec)

[ Up Loader ]
[LOADER FILE]: loader.bin
[ FILE SIZE ]: 15364 (byte)
[ TXsize     ] [ Time from Upload ] [ Upload Finish Time ]
13200(byte) ( 85.9(%) ) 14 ( Sec ) 2 ( Sec )_
  
```

9. The updating is complete with “[Upload Complete !]” message.

The FS-2570C is displayed as follow.

- When the T-CPU is updated, [TRX PROGRAM UPDATE EEPROM ALL CLEAR SELECT MACHINE TYPE PLEASE POWER OFF] appears.
- When the C-CPU is updated, RT display appears.

```

完了 - contup
自動
[Waiting For Target Wake up.... ] Time :  8 (sec)

[ Up Loader  ]
[LOADER FILE]: loader.bin
[ FILE SIZE ]: 15364 (byte)
[ TXsize    ] [ Time from Upload ] [ Upload Finish Time ]
15360(byte) (100.0%)      18 ( Sec )      0 ( Sec )
[ Up Application ]
[ APP FILE ]: fs1570pn.bin
[ FILE SIZE ]: 820274 (byte)
[ Message  ]: NOW ERASING Messege...

Just Moment Please  3
[ TXsize    ] [ Time from Upload ] [ Upload Finish Time ]
820273(byte) (100.0%)      325 ( Sec )      0 ( Sec )
Finish Send Application program!
[ Up Application ]: UpLoad Application Program!
[ Upload Complete ! ]
A:¥cont>cd ..

A:¥>

A:¥>

```

10. Turn off the system and on it again.

11. When updating T-CPU and C-CPU, perform ALL CLEAR. See page 3-2.

12. Confirm the program version level as below.

Checking detail program version

Carry out the self-test by pressing [3] with the DSC display. After the test, press [1:RT] 5 times while holding [FILE] to show the program version in detail.

Table 4.4.1 Test Item and program

Test Item	Program
MAIN CPU	T-CPU
PANEL-1	C-CPU for No.1 FS-2570C
PANEL-2	C-CPU for No.2 FS-2570C
MODEM	DSC MODEM
NBDP MODEM	NBDP MODEM

4.4.2 DSC MODEM and NBDP MODEM

To update DSC MODEM and NBDP MODEM program;

1. Turn off the system. FS-1570T/FS-2570T.
2. Connect the PC. See 4.2 Connection.
3. Confirm that DIP switch S3-#3 and #4 on T-CPU board is on.
4. Insert the floppy disk which contains the latest program into the drive A.
5. Double click the batch file icon of the program to be updated.
When updating by using DOS window, enter the batch file name to be updated.

Program to be updated	Command
DSC MODEM	UPDSC.BAT
NBDP MODEM	UPNBDP.BAT

6. Updating program runs automatically.
7. When the message [TRGET POWER ON] appears, turn on the system.
You can see the message "LOAD CONFIG DATA FROM TRX UNIT" on FS-2750C.

```

A:¥>updsc.bat

A:¥>uppg prog.txt dsc¥modem.bin 0 0 200 2
Program upload utility Version 6.21
Copyright(c) FURUNO ELECTRIC CO.,LTD. 1997,1998,1999 (T.K)
uppg infile1 infile2 p1 p2 p3 p4 p5
p1: Deletion waiting time.
p2: Waiting time to write.
p3: Password output interval.
p4: ID number.
p5: Port number.(1,2...)
Erase Wait:0sec
Write Wait:0
Wait counter = 200
Port no. = 1
TARGET POWER ON.

```



8. The PC display changes as below. The updating is complete with “Finish version up” message. The FS-2570C display is changes to RT display.

```

A:¥>uppg prog.txt dsc¥modem.bin 0 0 200 2
Program upload utility Version 6.21
Copyright(c) FURUNO ELECTRIC CO.,LTD. 1997,1998,1999 (T.K)
uppg infile1 infile2 p1 p2 p3 p4 p5
p1: Deletion waiting time.
p2: Waiting time to write.
p3: Password output interval.
p4: ID number.
p5: Port number.(1,2...)
Erase Wait:0sec
Write Wait:0
Wait counter = 200
Port no. = 1
TARGET POWER ON.
Execute STEP1
Execute STEP2
29609Byte transfer
Now Erasing
Finish version up.
A:¥>

```



9. Turn off the system and on it again.
10. Check the program version level as below.

Checking program version

Carry out the self-test by pressing [3] with the DSC display. After the test, press [1:RT] 5 times while holding [FILE] to show the program version in detail.

Table 4.4.2 Test Item and program

Test Item	Program
MAIN CPU	T-CPU
PANEL-1	C-CPU for No.1 FS-2570C
PANEL-2	C-CPU for No.2 FS-2570C
MODEM	DSC MODEM
NBDP MODEM	NBDP MODEM

4.4.3 IB-581

To update IB-581;

1. Insert the floppy disk which contains the latest program into the FD drive.
2. Quit the terminal program of NBDP. Press [F2] key while pressing [Alt] and [Fn] keys. The prompt "A:¥FS¥TERMINAL>" will appears.
3. Press [B][:] and [Enter] to select drive B. Prompt "B:¥>" appears.
4. Press [U][P][5][8][1][E] and [Enter]. Updating starts automatically. Follow the instruction that appears.

When updating Russian version program:

Press [U][P][5][8][1][R] and [Enter].

5. The updating is complete with prompt "A:¥>".
6. Turn the terminal unit off and on it again.
7. To check the program number;
 - 1) Run "Self test" of [F6] system menu.
 - 2) Press [F1] while holding [Fn] and [Alt] to show the program version in detail.

How to reinstall IB-581 program

IB-581 is used commonly to Inmarsat B/C, NBDP(DP-6). To use IB-581 programmed for another system, the program is reinstalled by following the steps below.

1. Terminate the terminal program. For FELCOM81, press [F2] while holding [Alt] and [Fn]. Select "YES" and then press [Enter]. Prompt "A:/>" appears.
2. Type [F][O][R][M][A][T][Space][A][:]/[S] followed by [Enter]. Drive A is formatted and the system file is loaded.
3. Follow the instruction that appears.

Message	Key to be pressed
"Insert new diskette for drive A: and press ENTER when ready"	[Enter]
"Checking existing ---- Proceed with Format (Y/N)?"	[Y] and then [Enter]
"Formatting ---- Volume label (11 characters, ENTER for none)?"	[Enter]
"Volume Serial ---- Format another (Y/N)?"	[N] and then [Enter]

4. When updating is complete, prompt "A:/>" appears.

5. Install the terminal program.
Press [I][N][S][T][A][L][L] and [Enter]. Updating starts automatically. Follow the instruction that appears.

When updating Russian version program:

Press [R][U][S][I][N][S][T] and [Enter].

6. The updating is complete with prompt "B:/>".
7. Turn the terminal unit off and on it again.
8. To check the program number;
 - 1) Run "Self test" of [F6] system menu.
 - 2) Press [F1] while holding [Fn] and [Alt] to show the program version in detail.

4.4.4 IB-583

According to the installed boot program, the procedure of updating differs as below.

- New boot program: Updating from the serial port, [DTE] and FDD

- Old boot program (shipping in 2002): Updating from the serial port, [DTE]

To distinguish the boot program, turn on IB-583 without the floppy disk in the floppy disk drive. When the drive LED lights twice, the program is new. When lights once, the program is old.

Updating from the serial port, [DTE]

1. Turn off IB-583.
2. Connect the PC. See 4.2.
3. Insert the floppy disk contains the latest program into the slot of the PC.
4. Double click the batch file icon of the program to be updated. When updating from DOS window, type the batch file name.

Program to be updated	Command
IB-583	UP583.BAT

5. The updating file runs automatically. No message appears on IB-583 display.
6. When the message “[Waiting For Target Wake up...] Time: x (sec)” appears, turn on IB-583 within 25 seconds. If the message “Time Out Error!” appears, close the display by pressing [C] while holding down [Ctrl], and repeat from step 4.
7. Updating automatically starts.
8. Updating is completed with “Update Complete”. Normal display appears on IB-583.
9. Turn off the system and on it again.

To check the detail program number;

- 1) Run “Self test” of [F6] system menu.
- 2) Press [F1] while holding [Fn] and [Alt] to show the program version in detail.

Updating from FDD

1. Turn off IB-583.
2. Insert the floppy disk containing the latest program into the floppy disk drive.
3. Turn on IB-583.
4. The program runs automatically and the message below appears.

```
FD BOOT Ver.1.xx  
Update IB583 TERM  
Boot From FD ? (Yes/No) __
```
5. Press [Y]. The message below appears.

```
Loading : Load.bin ____ xx sec  
Fs-x570 NBDP Term Software Update  
Are you sure update ? (Y/N)
```
6. Press [Y]. Updating automatically starts.

```
Now erasing:  
Now updating program  
Update xx % (last xx sec)
```
7. When “Update xx%” is turned to be “100%”, the updating is completed. Normal display appears on IB-583.
8. Turn off the system and on it again.

To check the detail program number:

- 1) Run “Self test” of [F6] system menu.
- 2) Press [F1] while holding [Fn] and [Alt] to show the program version in detail.

4.5 Contents of Program File

The following show the detail of each program. Note that the file size is reference only.

1. C-CPU (FS-2570C)

Program number; 0550206-01.xx

Directory	File name	Size	Type
	upcont.bat	1kB	MSDOS batch file
cont	Fs1570pn.bin	911kB	Bin file
	Loader.bin	16kB	Bin file
	Main.cfg	1kB	Cfg file
	Uppg.exe	94kB	Application

*: Text in upcont.bat file
 cd cont
 uppg main.cfg
 cd..

2. T-CPU (FS-1570T/FS-2570T)

Program number; 0550205-01.xx

Directory	File name	Size	Type
	uptrx.bat	1kB	MSDOS batch file
trx	Fs1570tx.bin	515kB	Bin file
	Loader.bin	17kB	Bin file
	Main.cfg	1kB	Cfg file
	Uppg.exe	94kB	Application

*: Text in uptrx.bat file
 cd trx
 uppg main.cfg
 cd..

3. DSC MODEM (DSC DSP board) Program number; 0550207-01.xx

Directory	File name	Size	Type
	Prog.txt	1kB	Text document
	Updsc.bat	1kB	MSDOS batch file
	Uppg.exe	74kB	Application
dsc	Modem.bin	29kB	Bin file

Text in Updsc.bat file

```
uppg prog.tex dsc/modem.bin 0 0 200 2 %1
```

4. NBDP MODEM (NBDP DSP board) Program number; 0550208-01.xx

Directory	File name	Size	Type
	Prog.txt	1kB	Text document
	Upnbdp.bat	1kB	MSDOS batch file
	Uppg.exe	74kB	Application
nbdp	Modem.bin	45kB	Bin file

Text in Upnbdp.bat file

```
uppg prog.tex nbdp/modem.bin 0 0 200 3 %1
```

5. IB-583 (FS-1570/FS-2570 NBDP terminal) Program number; 0550209-22.xx

Directory	File name	Size	Type
	Boot.ini	1kB	Initial file
	Ib583.bin	695kB	Bin file
	Load.bin	55kB	Bin file
	Up583.bat	1kB	MSDOS batch file
	Uppg.exe	94kB	Application

Text in up583.bat file

```
uppg -lf load.bin -hf ib583.bin -cpu 1 -port 1 -T 25 -TL 100 -TH 100 -DW 50
```

6. IB-581 (FS-1570/FS-2570 NBDP terminal) Program number; 0550210-22.xx

Directory	File name	Size	Type
config	Format.com	27kB	MSDOS application
	Config.rus	1kB	Rus file
	Config.eng	1kB	Eng file
	Autoexec.eng	1kB	Eng file
	Autoexec.rus	1kB	Rus file
rusdrv	Enh_font.exe	26kB	application
terminal	fs.exe	404kB	application
	Itu9107.cnl	9kB	Cnl file
	English.dat	29kB	Dat file
	Russian.dat	30kB	Dat file
	Install.bat	1kB	MSDOS batch file
	Rusinst.bat		MSDOS batch file
	Readme.jpn	1kB	Jpn file
	Up581e.bat	1kB	MSDOS batch file
	Up581r.bat	1kB	MSDOS batch file

Text in install.bat file

```

echo Copying Terminal program...
prompt $p$g
a:
cd ¥
md A:¥fs
md A:¥fs¥terminal
copy B:¥terminal¥English.dat A:¥fs¥terminal
copy B:¥terminal¥Itu9107.cnl A:¥fs¥terminal
copy B:¥terminal¥FS.exe      A:¥fs¥terminal
copy A:¥config.sys A:¥config.fs /Y
copy A:¥autoexec.bat A:¥autoexec.fs /Y
copy B:¥config¥config.eng A:¥config.sys /Y
copy B:¥config¥autoexec.eng A:¥autoexec.bat /Y
copy B:¥config¥format.com A:¥format.com /Y
@ECHO OFF
echo NBDP TERMINAL SET UP Complete.
@ECHO ON

```

Text in rusinst.bat file

```

echo Copying Terminal program...
prompt $p$g
a:
cd ¥
md A:¥fs

```

```

md A:\fs\terminal
md A:\rusdrv
copy B:\terminal\Russian.dat A:\fs\terminal
copy B:\terminal\Itu9107.cnl A:\fs\terminal
copy B:\terminal\Fs.exe      A:\fs\terminal
copy B:\rusdrv\*.exe A:\rusdrv\*. *
copy A:\config.sys    A:\config.fs
copy A:\autoexec.bat A:\autoexec.fs
copy B:\config\config.rus A:\config.sys
copy B:\config\autoexec.rus A:\autoexec.bat
copy B:\config\format.com A:\format.com
@ECHO OFF
echo NBDP TERMINAL SET UP Complete.
@ECHO ON

```

Text in UP581E.bat file

```

echo Copying Terminal program...
prompt $p$g
a:
cd \
md A:\fs
md A:\fs\terminal
cd dp10
cd terminal
del English.dat
del Itu9107.cnl
del FS.exe
del a:\dp10\terminal\dp10.sav
del a:\dp10\terminal\dp10.stn
del a:\dp10\terminal\dp10.aut
del a:\dp10\terminal\dp10.scn
del a:\dp10\terminal\dp10.cnl
del a:\dp10\terminal\dp10.id
del a:\dp10\terminal\dp10.man
del a:\dp10\terminal\*. *
cd ..
rmdir terminal
del a:\dp10\*. *
cd ..
rmdir dp10
copy B:\terminal\English.dat A:\fs\terminal
copy B:\terminal\Itu9107.cnl A:\fs\terminal
copy B:\terminal\Fs.exe      A:\fs\terminal
copy A:\config.sys A:\config.fs /Y
copy A:\autoexec.bat A:\autoexec.fs /Y
copy B:\config\config.eng A:\config.sys /Y
copy B:\config\autoexec.eng A:\autoexec.bat /Y

```

```
copy B:\config\format.com A:\format.com /Y
@ECHO OFF
echo NBDP TERMINAL SET UP Complete.
@ECHO ON
```

Text in UP581R.bat file

```
echo Copying Terminal program...
prompt $p$g
a:
cd \
md A:\fs
md A:\fs\terminal
md A:\rusdrv
cd dp10
cd terminal
del Russian.dat
del Itu9107.cnl
del FS.exe

del a:\dp10\terminal\dp10.sav
del a:\dp10\terminal\dp10.stn
del a:\dp10\terminal\dp10.aut
del a:\dp10\terminal\dp10.scn
del a:\dp10\terminal\dp10.cnl
del a:\dp10\terminal\dp10.id
del a:\dp10\terminal\dp10.man
del a:\dp10\terminal\*. *

cd ..
rmdir terminal
del a:\dp10\*. *
cd ..
rmdir dp10
copy B:\terminal\Russian.dat A:\fs\terminal
copy B:\terminal\Itu9107.cnl A:\fs\terminal
copy B:\terminal\FS.exe A:\fs\terminal
copy B:\rusdrv\*.exe A:\rusdrv\*. *
copy A:\config.sys A:\config.fs
copy A:\autoexec.bat A:\autoexec.fs
copy B:\config\config.rus A:\config.sys
copy B:\config\autoexec.rus A:\autoexec.bat
copy B:\config\format.com A:\format.com
@ECHO OFF
echo NBDP TERMINAL SET UP Complete.
@ECHO ON
```

Chapter 5. Block Description

5.1 Configuration

See Chapter 1 for system configuration.

5.1.1 Transceiver unit

Fig.5.1.1 shows the block diagram of the transceiver unit, FS-1570T.

- DSP board (05P0751) is needed for NBDP communication.
- DSC general frequencies receiver board (05P0734) cannot be installed in FS-1570T. During the scanning reception of DSC general frequencies by using TX/RX board, radiotelephone and NBDP cannot be used.

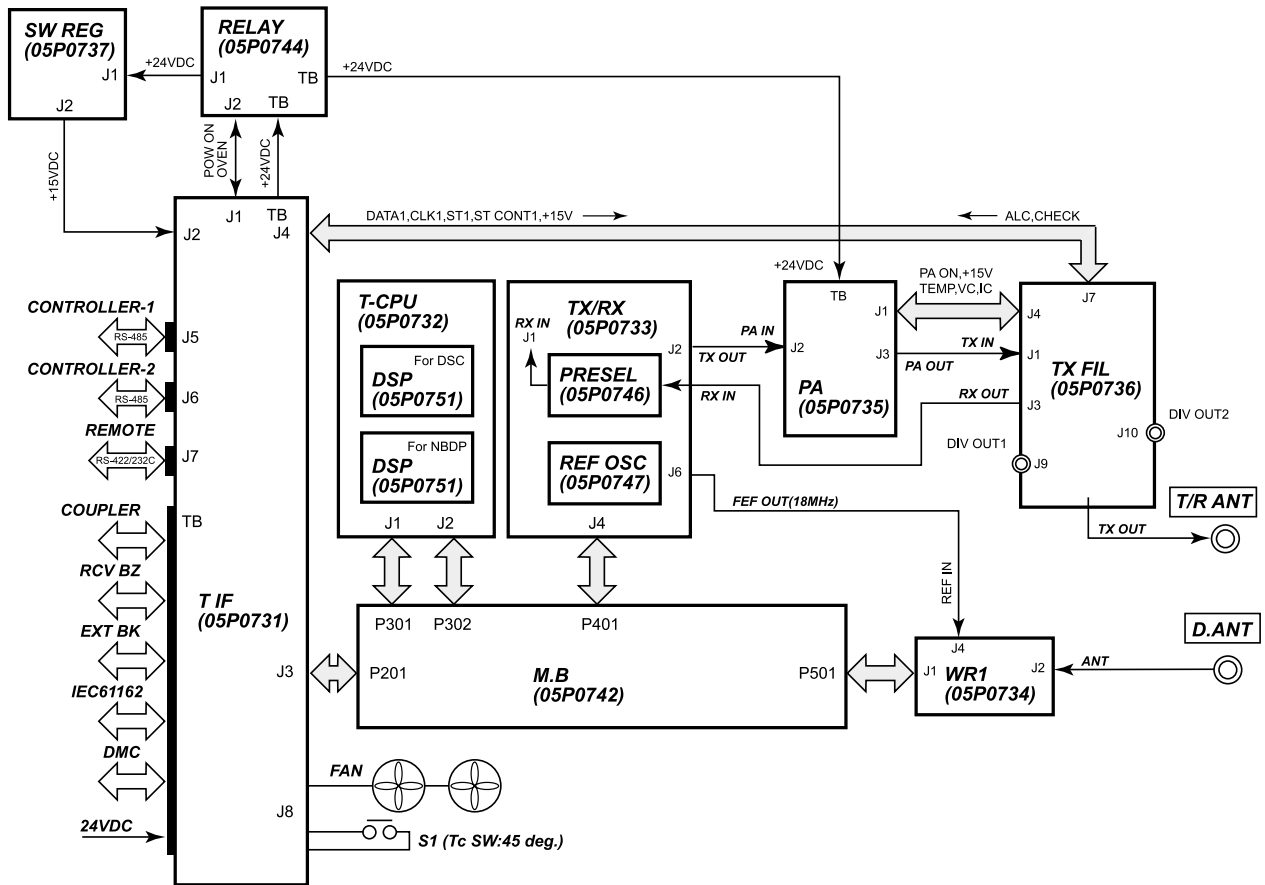

Fig.5.1.1 Block diagram of FS-1570T

Fig.5.1.2 is the block diagram of the transceiver unit, FS-2570T.

- DSP board (05P0751) is needed for NBDP communication.
- DSC general frequencies receiver board (05P0734) can be installed optionally. The DSC general frequencies receiver is connected to 2.6 m whip antenna with preamplifier FAX-5 or MF/HF antenna. Jumper setting on TX FIL board (05P0736) are changed according to the antenna type.

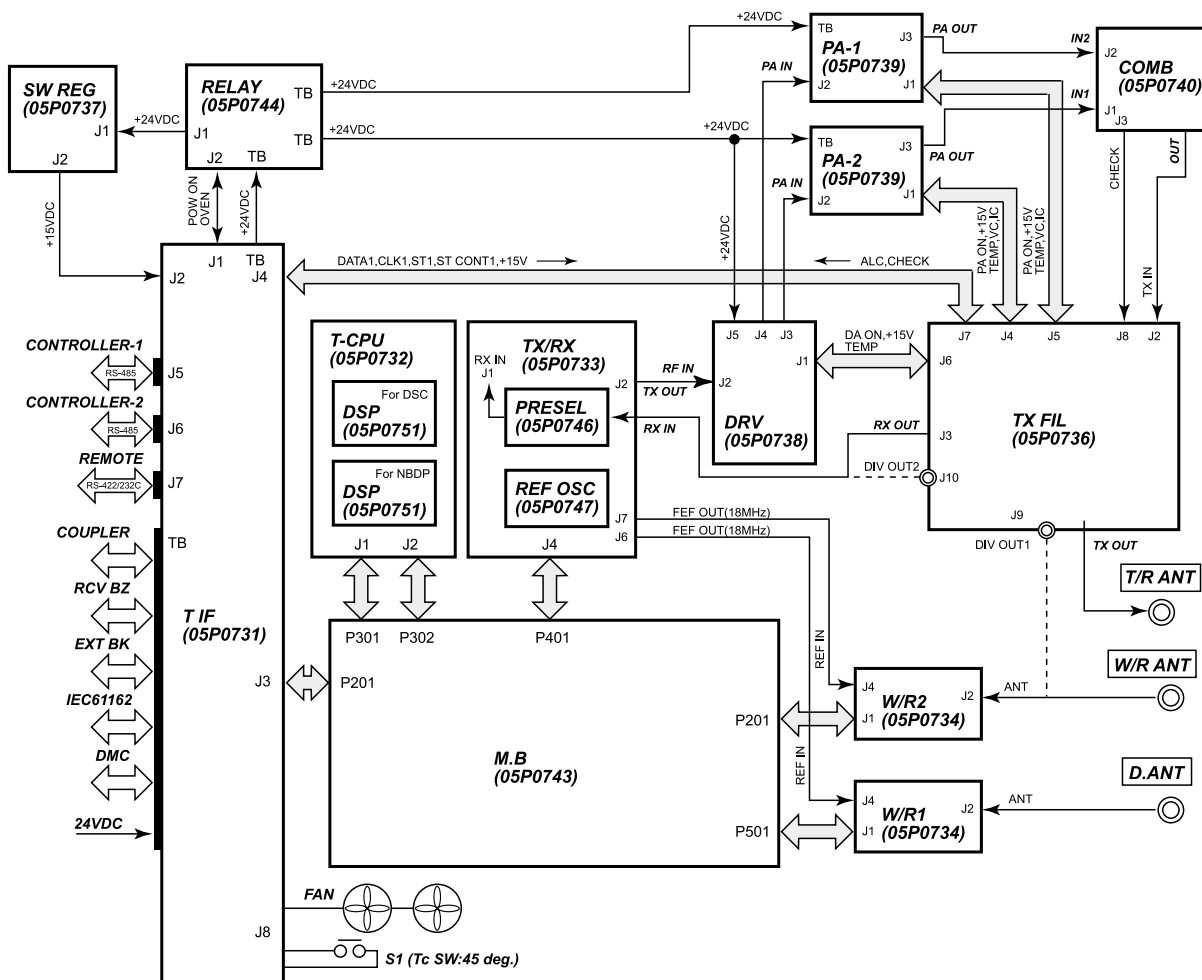

Fig.5.1.2 Block diagram of FS-2570T

5.1.2 Boards in Transceiver unit

Table 5.1.1 lists the function of each board in the transceiver unit.

Table 5.1.1 Boards in Transceiver unit

Board	Type	Function	Remarks
T-CPU	05P0732	1) Consisting of Main CPU, SUB CPU-1 (I/F), SUB CPU-2 (I/F) and associated circuits. The DIP switches on this board are set depending on system configuration.	FS-1570T/ 2570T
DSP (For DSC)	05P0751	1) Consisting of DSP, Modem and Flash ROM. 2) DSC program is stored in Flash ROM. 3) The serial communication is made between the DSC DSP and Main CPU.	
DSP (For NBDP)	05P0751	1) Consisting of DSP, Modem and Flash ROM 2) NBDP program is stored in Flash ROM. 3) NBDP DSP communicates with Main CPU in parallel.	
TX/RX	05P0733	1) Consisting of modulator and demodulator for DSC, NBDP and VOICE signals, and local oscillators. AF input/output signal: 600 Ω / -10 dBm Output power: 0.5 W The board outputs S, RXAF, TXAF and TXOUT (RF) signals to T-CPU board for checking.	
PRESEL	05P0746	1) Consisting of 5 filters. 2) 1.45 to 4.99 MHz filter consists of tuning circuits. An adequate capacitor is selected by a relay for the selected frequency. Other four filters is a band pass filter.	
REF OSC	05P0747	1) This board is a 18 MHz reference oscillator. 2) The output is sent to T/R, W/R1 and W/R2 boards. When the transceiver unit is supplied 24V, +12 V (oven voltage) is supplied to the oven. TEMP signal is output to T-CPU board. If the TEMP signal is lower than the designed value, the transceiver does not transmit.	
W/R1	05P0734	1) This board is a DSC distress safety receiver, consisting of RF amplifier, a demodulator, an AF amplifier and local oscillators. 2) The board uses 18 MHz reference signal from REF OSC board. For self test, 18 MHz signal is applied to the antenna circuit (RF connection). 3) The T-CPU identifies W/R board with INST signal. W/R1 board is identical to W/R2 board.	
PA	05P0735	1) Two stage push-pull amplifier outputs 150 W signal. power gain: 27 dB 2) Check signal output to T-CPU: TEMP, VC and IC	FS-1570T

Board	Type	Function	Remarks
TX FIL	05P0736	1) Consisting of 7 band L.P.Fs. 2) The filter eliminates and suppresses unwanted signal generated at PA. Check signal output to T-CPU: IN-Vr/Vf, OUT-Vr/Vf and ALC	FS-1570T/ 2570T
SW REG	05P0737	Input voltage: 24 VDC Output voltage: +15 VDC (5 A max) Switching frequency: 220 kHz.	
RELAY	05P0744	Consisting of; 1) On/Off relay in 24 V lines for PA1 and PA2 2) 25 A breakers in 24 V lines for PA1 and PA2 3) +12 V AVR 4) 16 V lowvoltage protector 5) 35 V overvoltage protector	
T-IF	05P0731	Consisting of; 1) Connectors and terminal board for external equipment 2) Amplifiers for LINE IN and LINE OUT signals.	
MB	05P0742	Mother board	FS-1570T
DRV	05P0738	2 stage push-pull amplifier; output power: 30 W; power gain: 20 dB. Check signal output to T-CPU: TEMP	FS-2570T
PA	05P0739	Single stage push-pull amplifier; output power: 125 W; Power gain: 10 dB Check signal output to T-CPU: TEMP, VC and IC	
COMB	05P0740	Mixes outputs of PA-1 and PA-2 to obtain 250W. Check signal output to T-CPU: COMB CHK	
W/R2	05P0734	DSC general frequency receiver, identical to W/R1. T-CPU recognizes W/R2 by INST2 signal. T-CPU sends frequency data to be scanned to TX/RX board at the absence of INST2 signal.	
MB	05P0743	Mother board	

5.1.3 Control unit, FS-2570C

Two control units can be connected to the transceiver unit. The system is turned on and off by the control unit connected to [CONT-1] port on the transceiver unit. The control unit communicates with the transceiver unit, using RS-485. The LINE IN/OUT level between two units is 600 Ω/-10 dBm.

The printer, PP-510 is connected to the control unit connected to [CONT-1] port for printing DSC and NBDP messages. When IB-581/583 is used as a NBDP terminal, the printer is connected via IF-8500.

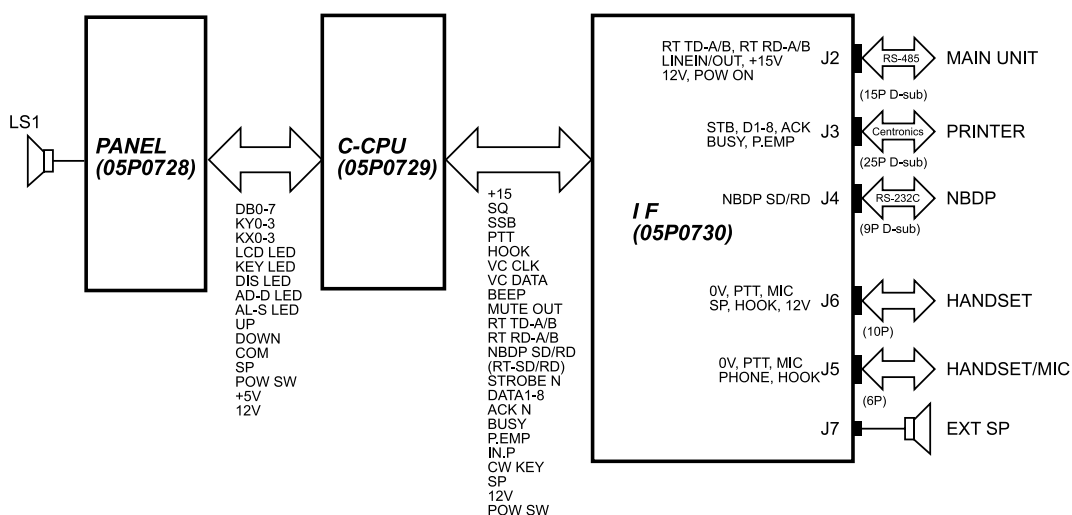

Fig.5.1.3 Block diagram of FS-2570C

Table 5.1.2 lists the boards in FS-2570C.

Table 5.1.2 Boards in FS-2570C

Unit	Board	Type	Function	Remarks
FS-1570C	C-IF	05P0730	Consisting of; 1) Connectors for external units 2) Volume adjuster 3) Audio power amplifier, TA7752AP	FS-1570 /2570
	C-CPU	05P0729	The C-CPU communicates with; 1) TR unit, using RS-485 2) NBDP terminal, using RS-232C 3) Printer, using Centronics 4) Hook and PTT signal detectors	
	PANEL	05P0728	Keys and LCD	

5.1.4 NBDP Terminal unit: IB-581/583 (Option)

IB-583 is a NBDP terminal newly developed for FS-1570/2570. The terminal program for IB-583 differs from one for IB-581. The operation of IB-583 is almost the same as one of DP-6.

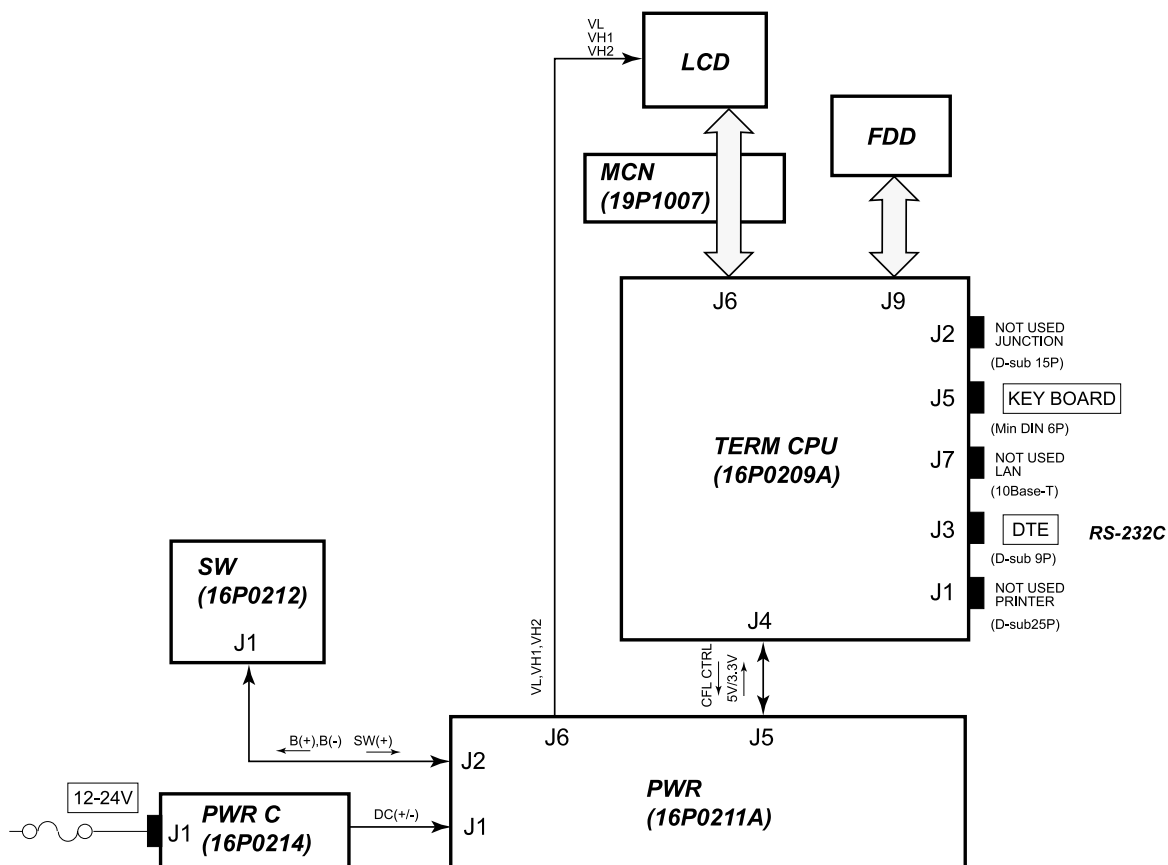

Fig.5.1.4 Block diagram of IB-583

Table 5.1.3 Boards in IB-583

Unit	Board	Type	Function	Remarks
IB-583	TERM CPU	16P0209A	1) Controlling display. 2) Communicating with FS-2570C (RS-232C).	FS-1570 /2570
	SW	16P0212	Power switch circuit	
	PWR	16P0211A	Generates 6.5 V, 3.3 V, 5 V and power for LCD	
	PWR C	16P0214	Power connector and filter	
	LCD		NL6448BC33-46	
	FDD		JU-226A032FCK2149 (For 2HD)	

Connecting IB-581/583

IB-581 can be connected to the transceiver unit as below. The printer is connected via IF-8500.

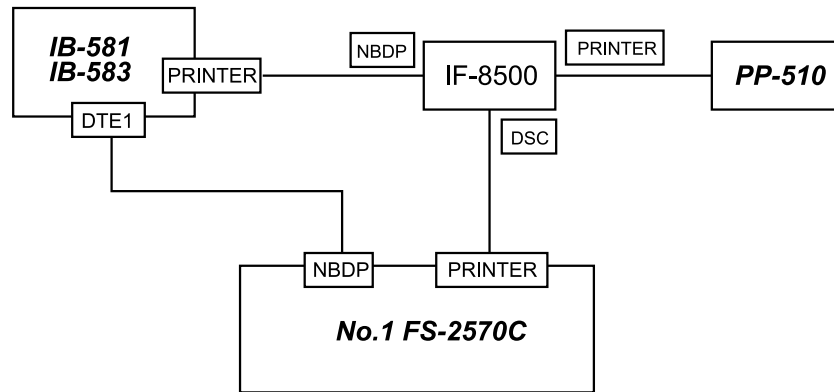

Fig.5.1.5 Connecting IB-581/583

5.1.5 Antenna coupler unit

There are two antenna coupler units: AT-1560-15 is for 150W SSB and AT-1560-25 is for 250W SSB. Both units include the same matching circuit, but AT-1560-25 is designed for higher voltage ratings. When the system is switched off, the antenna is grounded via the dummy board. The resin case and the stainless steel case are available.

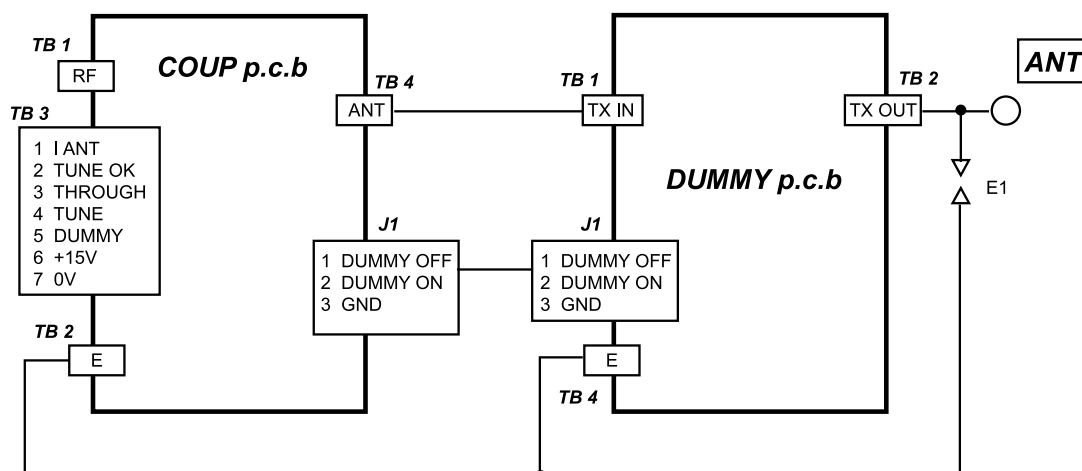

Fig.5.1.6 Block diagram of AT-1560

Table 5.1.4 Boards in AT-1560

Board	Unit	Type	Function	Remarks
COUP	AT-1560-15	05P0528	Antenna matching, capability of 7 m antenna connection	FS-1570
	AT-1560-25	05P0528A	Same as AT-1560-15, but for high voltage	FS-2570
DUMMY	AT-1560-15	05P0543	10Ω+250pF, 100W dummy load	FS-1570
	AT-1560-25	05P0610	10Ω+250pF, 200W dummy load	FS-2570

Table 5.1.5 Type of antenna coupler

Type	Code number	Remarks
AT-1560-15-AAS	000-055-245	For FS-1570, resin case
AT-1560-15-SUS	000-055-263	For FS-1570, stainless steel case
AT-1560-25-AAS	000-055-255	For FS-2570, resin case
AT-1560-25-SUS	000-055-265	For FS-2570, stainless steel case

5.2 Power supply unit

5.2.1 General

Fig.5.2.1 shows power supply lines in the system.

When two FS-2570Cs are used, only the unit which is connected to [CONT-1] port can turn on and off the system. No.1 controller unit should be installed in W/H.

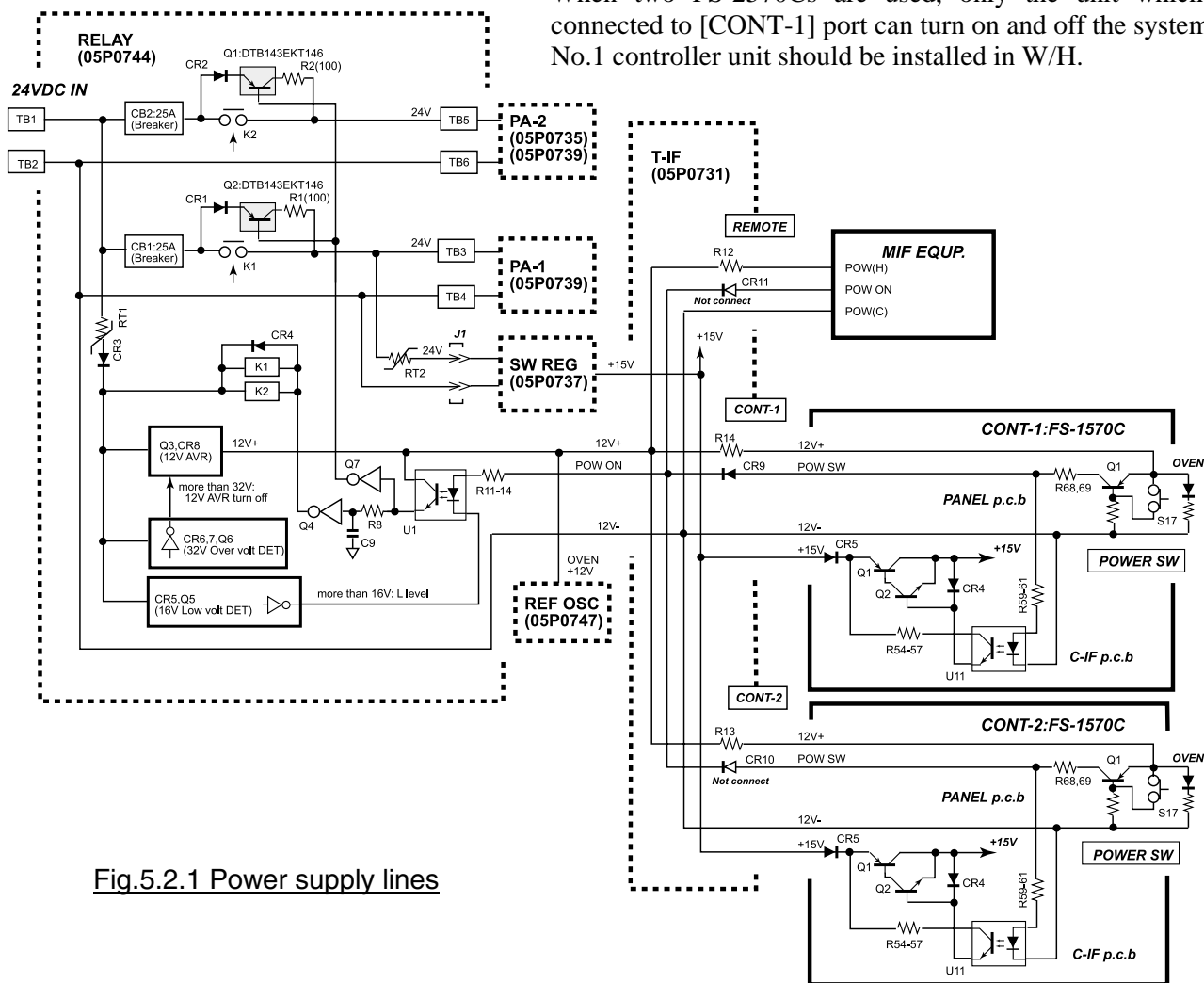

Fig.5.2.1 Power supply lines

Table 5.2.1 summaries protectors provided on RELAY board.

Table 5.2.1 Protectors in power supply circuit

RELAY board (05P0744)	Lowvoltage protector	CR5 and Q6 which control U1.
	Overtoltage protector	CR6, CR7 and Q6 which control +12 V AVR consisting of Q3 and CR8.
	PA1 over current protector	25 A breaker (CB1)
	PA2 over current protector	25 A breaker (CB2)
	SW REG board protector (05P0737)	Polyswitch (RT2), REU900 (Ih=9 A/It=18 A)
	+12 V AVR protector	Polyswitch (RT1), REU135 (Ih=1.35 A/It=2.7 A)

5.2.2 RELAY board (05P0744)

RELAY board consists of relay circuits, +12 V AVR and low/over voltage protectors. When the transceiver unit is powered by 24 V, 12 V AVR, consisting of Q3 and CR8, outputs +12 V to the power switch circuit in the No.1 controller. "POW ON" signal is sent from CONT-1 board to U1, and Q4 and Q7 are driven to conduct.

Q7 is connected to inrush current limiters, CR2/Q1/R2 and CR1/Q2/R1, and Q4 to relays, K1 and K2.

Q4 is connected to U1 via the delay circuit, R8 and C9, so that relays are on after inrush current suppression. Thus, the relay contact failure will not result.

5.2.3 SW REG board (05P0737)

SW REG board consists of the switching regulator circuit and 20 V AVR consisting of Q1, Q2 and VR1. The switching frequency of $220\text{ kHz} \pm 20\text{ kHz}$ is adjusted by C13 connected to U1. Test points TP1 (+) and TP2 (-) are used to measure the switching frequency. The switching regulator outputs +15 V, 3 A (typical) in about 70 % efficiency. R20 adjusts +15 V.

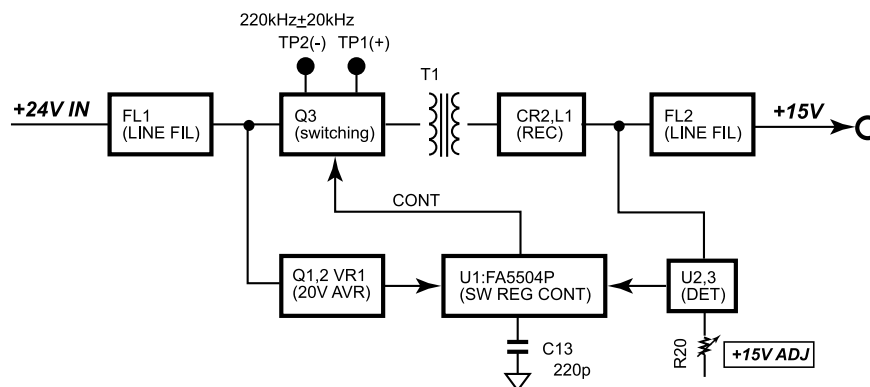

Fig.5.2.2 SW REG (05P0737)

5.3 T-CPU board (05P0732)

Fig.5.3.1 shows the block diagram of the T-CPU board.

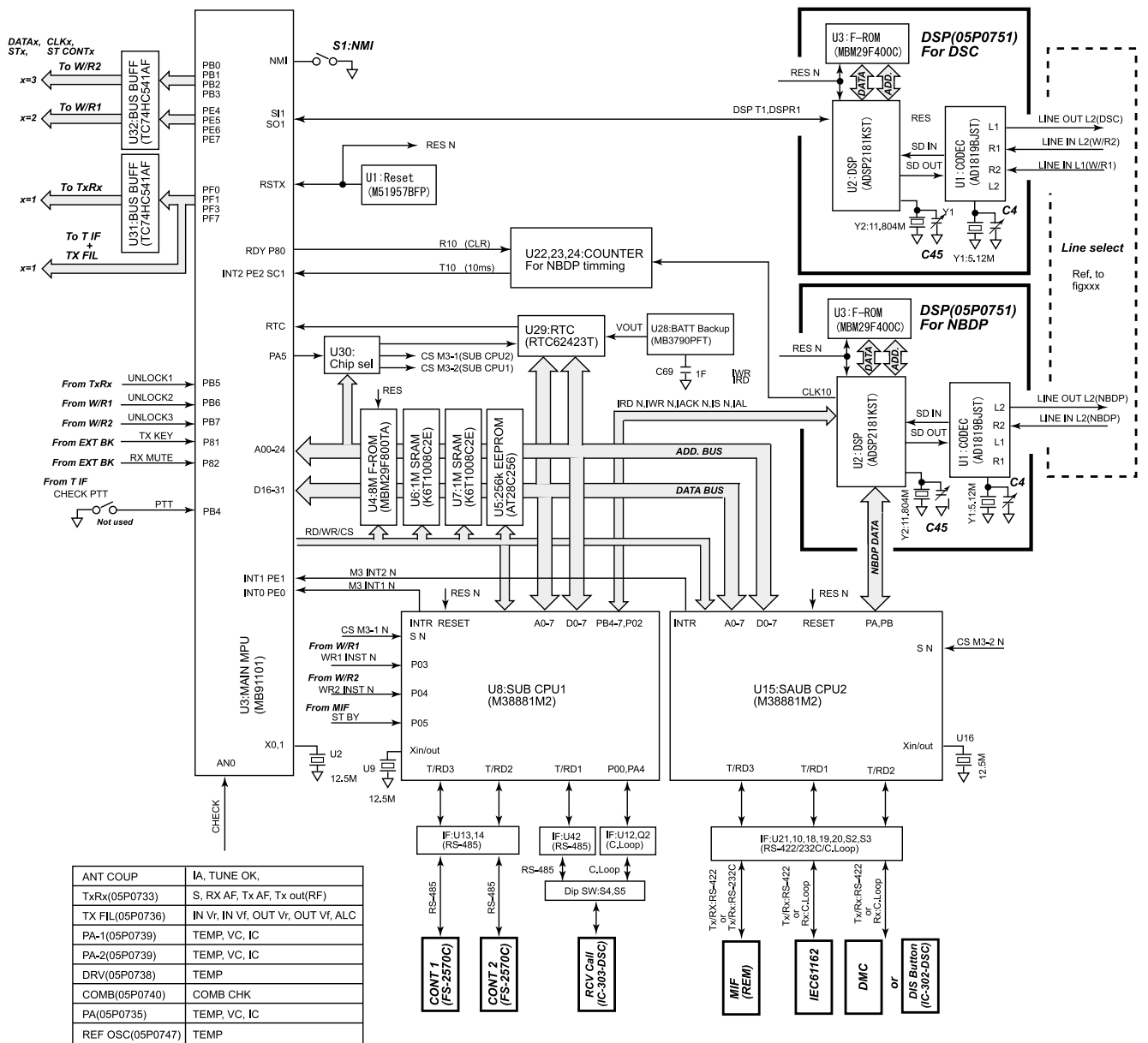

Fig.5.3.1 Block diagram of T-CPU (05P0732)

5.3.1 Function of CPU

Three CPUs, 32-bit MAIN CPU, 8-bit SUB CPU-1 (I/O) and 8-bit SUB CPU-2 (I/O) work as shown in Table 5.3.1.

Table 5.3.1 Function of CPU

CPU	Function
MAIN CPU (U3, MB91101)	<ol style="list-style-type: none"> 1) Communicates with SUB CPU-1, SUB CPU-2, FS-2570C, MIF interface units and DMC 2) Encoding and decoding of DSC and NBDP messages 3) Decides the timing for NBDP communication 4) Interfaces with DSC DSP and NBDP DSP 5) Reads check signals 6) Controls external BK, antenna coupler and IC-302/IC-303-DSC 7) Receives NMEA signal
SUB CPU-1 (I/O) (U8, M38881M2)	<ol style="list-style-type: none"> 1) Communicates with Main CPU 2) Interfaces with Incoming Indicator, No.1 and No.2 FS-2570C 3) Detects the absence of W/R1 and W/R 2
SUB CPU-2 (I/O) (U15, M38881M2)	<ol style="list-style-type: none"> 1) Communicates with Main CPU 2) Interfaces with IEC61162 device, DMC-5, IC-302-DSC, NBDP DSP and MIF devices

5.3.2 Memory

Table 5.3.2 shows the memory contents.

Table 5.3.2 Memory contents

Memory	Contents
8 Mbit Flash ROM (U4, MBM29F800TA)	<ol style="list-style-type: none"> 1) RT, DSC and NBDP programs 2) Default settings of DSC system setup menu 3) Default settings of RT system setup menu 4) ITU channels
256 kbit EEPROM (U5, AT28C256)	<ol style="list-style-type: none"> 1) Settings of DSC system setup menu 2) Settings of RT system setup menu 3) MMSI and model 4) User channels 5) Communication log
1 Mbit SRAM (U6 and U7, K6T1008C2E)	Used by MAIN CPU as working memory

5.3.3 Control signals

Control signals generated by the T-CPU are sent to TX FIL, T-IF, TX/RX and W/R boards after serial to parallel conversion using shift registers in each board. Data 1 is delivered to TX FIL, TX-IF and TX/RX boards, Data 2 to W/R1 board and Data 3 to W/R2 board. Tables 5.3.3 to 5.2.6 list the signals derived from Data 1 to 3.

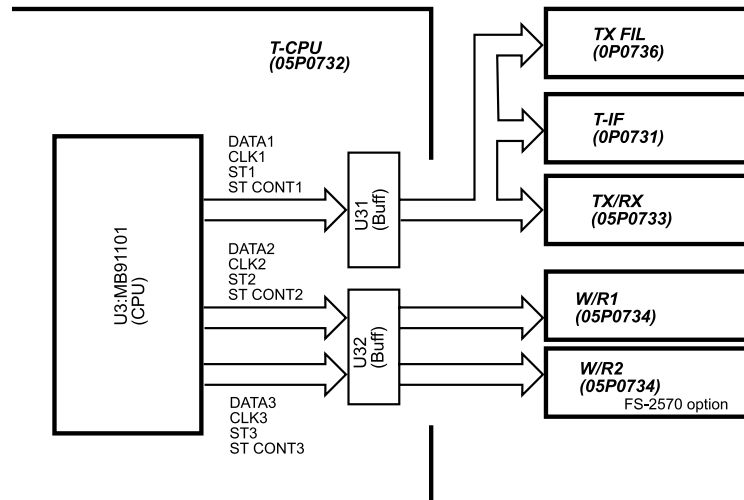

Fig.5.3.2 Output circuit of Control signals

Table 5.3.3 Signals generated by DATA 1 on TX FIL Board

TX FIL	Pin No. & Name		Order of execution	Signal name	Function
U1	-		1-8	N.C	Not used
U2	-		9-16	N.C	Not used
U4	#16	Q1	17	PA ON1, PA ON2	Turns on/off Power amplifier on PA board (FS-1570T: 05P0735; FS-2570T: 05P0739)
	#15	Q2	18	DA ON	Turns on/off Driver on DRV board (05P0738)
	#14	Q3	19	N.C	
	#13	Q4	20	A	Selects following check signals connected to U5 and U6 in order 1) ALC, CHK, OUTVf, OUTVr, INVf and INVr from TX FIL (05P0736) 2) VC1, IC1 and TEMP1 from PA (05P0735) 3) VC1, IC1, TEMP1, VC2, IC2 and TEMP2 from PA (05P0739) 4) DA TEMP from DRV (05P0738) 5) COMB CHK from COMB (05P0740)
	#12	Q5	21	B	
	#11	Q6	22	C	
	#10	Q7	23	INH 1	
#9	Q8	24	INH 2		
U3	#16	Q1	17	17.0 to 27.5 MHz LPF	Selects low pass filter on TX FIL board (05P0736)
	#15	Q2	18	11.0 to 17.0 MHz LPF	
	#14	Q3	19	7.0 to 11.0 MHz LPF	
	#13	Q4	20	5.0 to 7.0 MHz LPF	
	#12	Q5	21	3.5 to 5.0 MHz LPF	
	#11	Q6	22	2.3 to 3.5 MHz LPF	
	#10	Q7	23	1.605 to 2.3 MHz LPF	
#9	Q8	24	BK RL CONT	Switches 50 ohm BK relay, K15 on TX FIL board (05P0736)	

Table 5.3.4 Signals generated by DATA 1 on TX/RX board

TX/ RX	Pin No. & Name		Order of execution	Signal name	Function
U1	#15	QA	1	ST1 (NOR: ST CONT1)	ST signal to U44 for VCO frequency band selection
	#1	QB	2	ST2	ST signal to DDS (U42)
	#2	QC	3	ST3	ST signal to DDS (U45)
	#3	QD	4	ST (NOR: ST CONT1)	Used to generate latch timing signal for U3 to U8
	#4	QE	5	ST (NOR: ST CONT1)	ST signal to PLL (U43)
	#5	QF	6	N.C	
	#6	QG	7	N.C	
	#7	QH	8	N.C	
U2			9-16	N.C	Not used
U3	#15	QA	17	POWER data-1	D/A converted by R88 and sent to Automatic Power Control (APC) circuit to control output power
	#1	QB	18	POWER data-2	
	#2	QC	19	POWER data-3	
	#3	QD	20	POWER data-4	
	#4	QE	21	POWER data-5	
	#5	QF	22	POWER data-6	
	#6	QG	23	POWER data-7	
	#7	QH	24	POWER data-8	
U4	#15	QA	25	N.C	D/A converted by R138 for RF AGC voltage control
	#1	QB	26	N.C	
	#2	QC	27	RF GAIN data-1	
	#3	QD	28	RF GAIN data-2	
	#4	QE	29	RF GAIN data-3	
	#5	QF	30	RF GAIN data-4	
	#6	QG	31	RF GAIN data-5	
	#7	QH	32	RF GAIN data-6	
U5	#16	Q1	33	PR8	Selects capacitors in the tuning circuit for 1.45 to 4.99 MHz band on PRESEL board (05P0746)
	#15	Q2	34	PR7	
	#14	Q3	35	PR6	
	#13	Q4	36	PR5	
	#12	Q5	37	PR4	
	#11	Q6	38	PR3	
	#10	Q7	39	PR2	
	#9	Q8	40	PR1	
U6	#16	Q1	41	BPF2 (1.45 to 4.99 MHz)	Selects a filter (BPF) on PRESEL board (05P0746)
	#15	Q2	42	BPF5 (18 to 30 MHz)	
	#14	Q3	43	BPF4 (8 to 18 MHz)	
	#13	Q4	44	BPF3 (5 to 8 MHz)	
	#12	Q5	45	BPF1 (0.1 to 1.45 MHz)	
	#11	Q6	46	N.C	
	#10	Q7	47	N.C	
	#9	Q8	48	N.C	

(Cont'd)

TX/ RX	Pin No. & Name		Order of execution	Signal name	Function
U7	#16	Q1	49	TX	Generates TX signal (+12 V)
	#15	Q2	50	RX	Generates RX signal (+12 V)
	#14	Q3	51	N J3E	Switches between J3E and H3E demodulators
	#13	Q4	52	N H3E	
	#12	Q5	53	N.C	
	#11	Q6	54	N:Narrw (FL4: 450 Hz)	Selects bandwidth of IF filter (455 kHz)
	#10	Q7	55	M: Middle (FIL3: 2.4 k)	
	#9	Q8	56	W: Wide (FIL2: 6 k)	
U8	#16	Q1	57	AGC FAST	Sets AGC decay time to FAST
	#15	Q2	58	N.B CONT	Switches on/off Noise Blanker (U16)
	#14	Q3	59	AGC OFF	Sets AGC to OFF
	#13	Q4	60	TX H3E	Adds carrier signal at H3E transmission
	#12	Q5	61	A	Selects following check signals connected to U9. 1) S, RX AF CHK, TX AF CHK and TX OUT CHK from TX/RX (05P0733) 2) TEMP from REF OSC (05P0747)
	#11	Q6	62	B	
	#10	Q7	63	C	
	#9	Q8	64	INH	
U43	#5			PLL data	PLL data for PLL IC (U43)
U42	#8			1DDS data	DDS data for DDS IC (U42)
U45	#8			2DDS data	DDS data for DDS IC (U45)
U44	#16	Q1	17	BAND-1	Selects PLL Band, 100 kHz to 6 MHz
	#15	Q2	18	BAND-2	Selects PLL Band, 6 to 13.5 MHz
	#14	Q3	18	BAND-3	Selects PLL Band, 13.5 to 21.5MHz
	#13	Q4	20	BAND-4	Selects PLL Ban, 21.5 to 30 MHz
	#12	Q5	21	H/L	Divides each PLL band into two bands
	#11	Q6	22	N.C	
	#10	Q7	23	N.C	
	#9	Q8	24	TEST	Outputs receiver self-test signal (18 MHz)

Table 5.3.5 Signals generated by DATA 1 on T-IF board

T-IF	Pin No. & Name		Order of execution	Signal name	Function
U2			1-8	N.C	
U3	#15	QA	9	N.C	
	#1	QB	10	N.C	
	#2	QC	11	U4 ST (NOR: ST CONT1)	Used to generate latch signal for U4 by NOR gate U12 with ST CONT1 signal
	#3	QD	12	U5 ST (NOR: ST CONT1)	Used to generate latch signal for U5 by NOR gate U12 with ST CONT 1 signal
	#4	QE	13	N.C	
	#5	QF	14	N.C	
	#6	QG	15	N.C	
	#7	QH	16	N.C	
U4	#16	Q1	17	N.C	
	#15	Q2	18	N.C	
	#14	Q3	19	N.C	
	#13	Q4	20	N.C	
	#12	Q5	21	N.C	
	#11	Q6	22	MIF AF	
	#10	Q7	23	INT C	Selects LINE-IN signal from No.1 or No.2 FS-2570C, using analog switch U8 (TX AF OUT signal)
	#9	Q8	24	REM 1_2	Selects LINE-IN signal from No.1 or No.2 FS-2570C, using analog switch U8 (LINE OUT signal)
U5	#16	Q1	17	TX KEYED	Controls External BK, isolated with photocoupler U14, Driver Q4 provided
	#15	Q2	18	DUMMY	Controls antenna coupler
	#14	Q3	19	TUNE	
	#13	Q4	20	THROUGH	
	#12	Q5	21	A	
	#11	Q6	22	B	Selects IA and TUNE OK signals from the coupler, using U6
	#10	Q7	23	C	
	#9	Q8	24	INH	

Table 5.3.6 Signals generated by DATA 2 on W/R1 board

W/R1	Pin No. & Name	Order of execution	Signal name	Function
U502			PLL data	PLL data for PLL IC (U502)
U504	#15 QA	1	DDS2 LOAD A	LOAD signal for U506 (DDS2, 456.7 kHz)
	#1 QB	2	DDS1 LOAD B	LOAD signal for U501 (DDS1, 6 MHz PLL Ref)
	#2 QC	3	U503 ST (NOR: ST CONT2)	Used to generate latch signal for U503 by NOR gate ST CONT2 signal
	#3 QD	4	U502 ST (NOR: ST CONT2)	Used to generate latch signal for U502 by NOR gate ST CONT2 signal
	#4 QE	5	N.C	
	#5 QF	6	N.C	
	#6 QG	7	N.C	
U503	#7 QH	8	N.C	
	#16 Q1	9	BAND-1	PLL BAND selection (1.6 to 6 MHz)
	#15 Q2	10	BAND-2	PLL BAND selection (6 to 13.5 MHz)
	#14 Q3	11	BAND-3	PLL BAND selection (13.5 to 21.5 MHz)
	#13 Q4	12	BAND-4	PLL BAND selection (21.5 to 27.5 MHz)
	#12 Q5	13	H/L	Divides each band into 2 bands
	#11 Q6	14	TEST	Outputs W/R-1 self-test signal (18 MHz)
#10 Q7	15	LPF 1	RF filter selection (1.6 to 13.2 MHz)	
#9 Q8	16	LPF 2	RF filter selection (13.2 to 27.5 MHz)	

Control signals generated by Data 3 on W/R 2 board are the same as those on W/R 1 board.

5.3.4 Interface circuit

Table 5.3.7 lists the ports on the transceiver unit.

Table 5.3.7 Ports on transceiver unit

Port Name	Signal Name	I/F Type	Dip switch		Connection
CONTROLLER-1	TD1-A, TD1-B	RS-485	-		
	RD1-A, RD1-B				
CONTROLLER-2	TD1-A, TD1-B	RS-485	-		
	RD1-A, RD1-B				
REMOTE (MIF)	SD	RS-232C	S3-#1/2 OFF S3-#3/4 ON		Case 1
	RD				
	TD (MIF-A, MIF-B)	RS-422	Selectable with S2-#3 ON: RS-422 OFF: C.Loop,	-S3-#1/2 ON -S3-#3/4 OFF	Case2
	RD (MIF-R)	C.Loop			
IEC	TD (IEC-A, IEC-B)	RS-422	Selectable with S2-#1 OFF: C.Loop, ON: RS-422		
	RD (IEC-R)	C.Loop			
DMC	TD (DMC-A, DMC-B)	RS-422	Selectable with S2-#2 OFF: C.Loop, ON: RS-422	S6: all ON S7: all OFF	DMC
	RD (DMC-R)	C.Loop			
	TD (DMC-A, DMC-B)	C.Loop	S6: all OFF, S7: all ON		IC-302-DSC
	RD (DMC-R)	C.Loop			
RCV BZ	BZ OUT,	RS-422	S4: all OFF, S5: all ON		IC-xxx
	BZ IN, BZ CTR	C.Loop	S4: all ON, S5: all OFF		IC-303-DSC

RS-232C

The RS-232C signals, asynchronous data are represented by voltage levels with respect to a system common. The data is bi-polar: a +3 to +12 volt indicates an ON (space) condition while a -3 V to -12 volt indicates an OFF (Mark) condition. The “dead area” between +3 V and -3 V is designed to absorb line noise.

The 15 m limitation of cable length can be stretched to about 30 m for ordinary cable, if well screened and grounded, and about 100 m if the cable is low capacitance as well.

RS-422

RS-422 is a balanced interface. A pair of wires is used to carry each signal. The data is encoded and decoded as a differential voltage between sender and receiver. A typical truth table for a balanced interface is as follows:

$$V_A - V_B < -0.2 \text{ V} = 0, \quad V_A - V_B > +0.2 \text{ V} = 1$$

If lines A and B are close together, they will be affected almost identically by external electromagnetic noise. If the lines are also twisted together, then neither line is permanently closer to a noise source than the other. Hence the well known “twisted pair” is extremely effective in eliminating noise from the signal. The output signal level swings between 0 to +5 V. The RS-422 is designed for greater distance and higher baud rates than RS-232C.

RS-485

This is like RS-422 (balanced). It is half-duplex, and not just point-to-point but like Ethernet since all devices (nodes) on it share the same “bus”. The driver output signal level (loaded minimum) is +/-1.5 V.

Fig.5.3.3 shows the interface circuit on the T-CPU board.

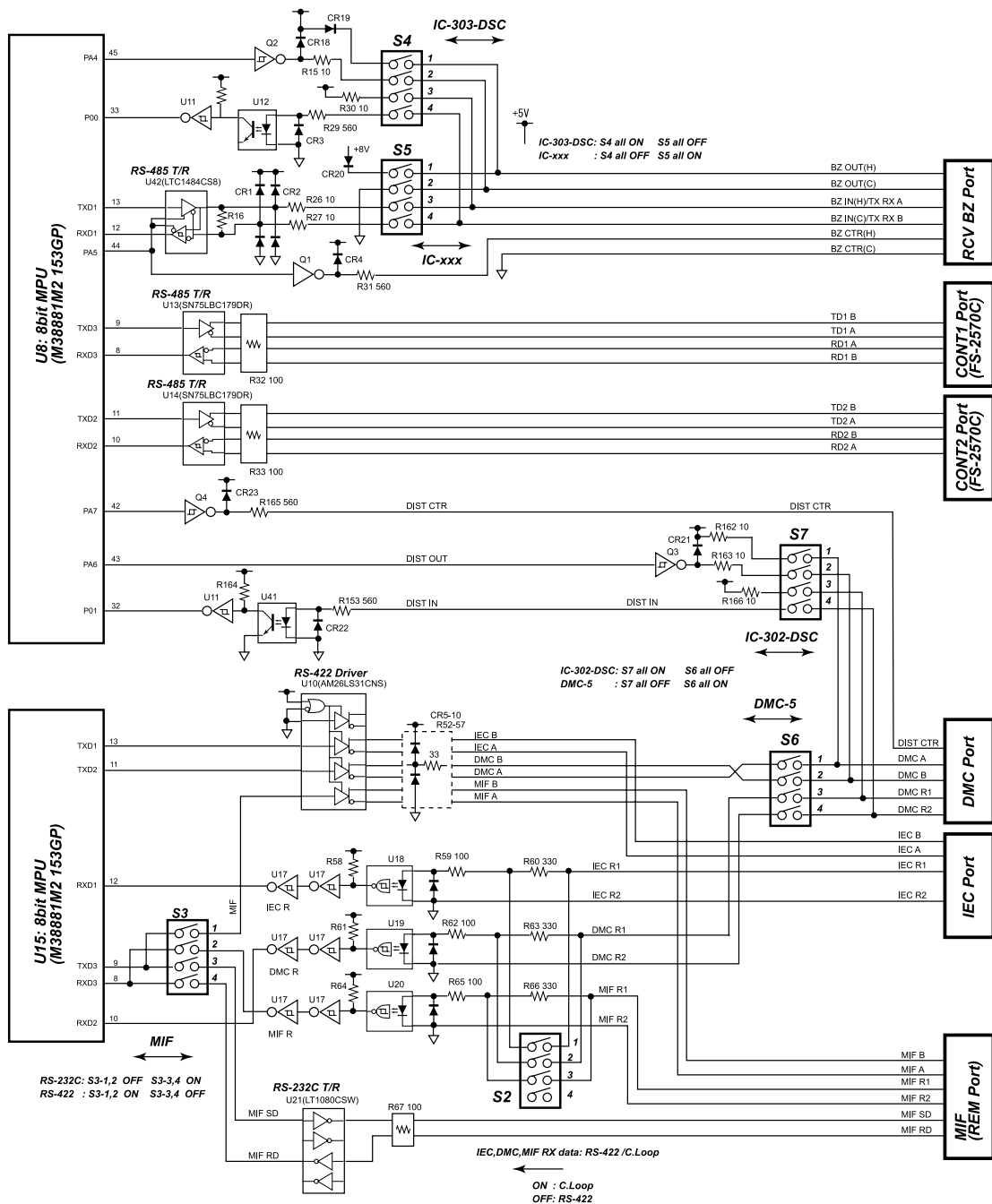
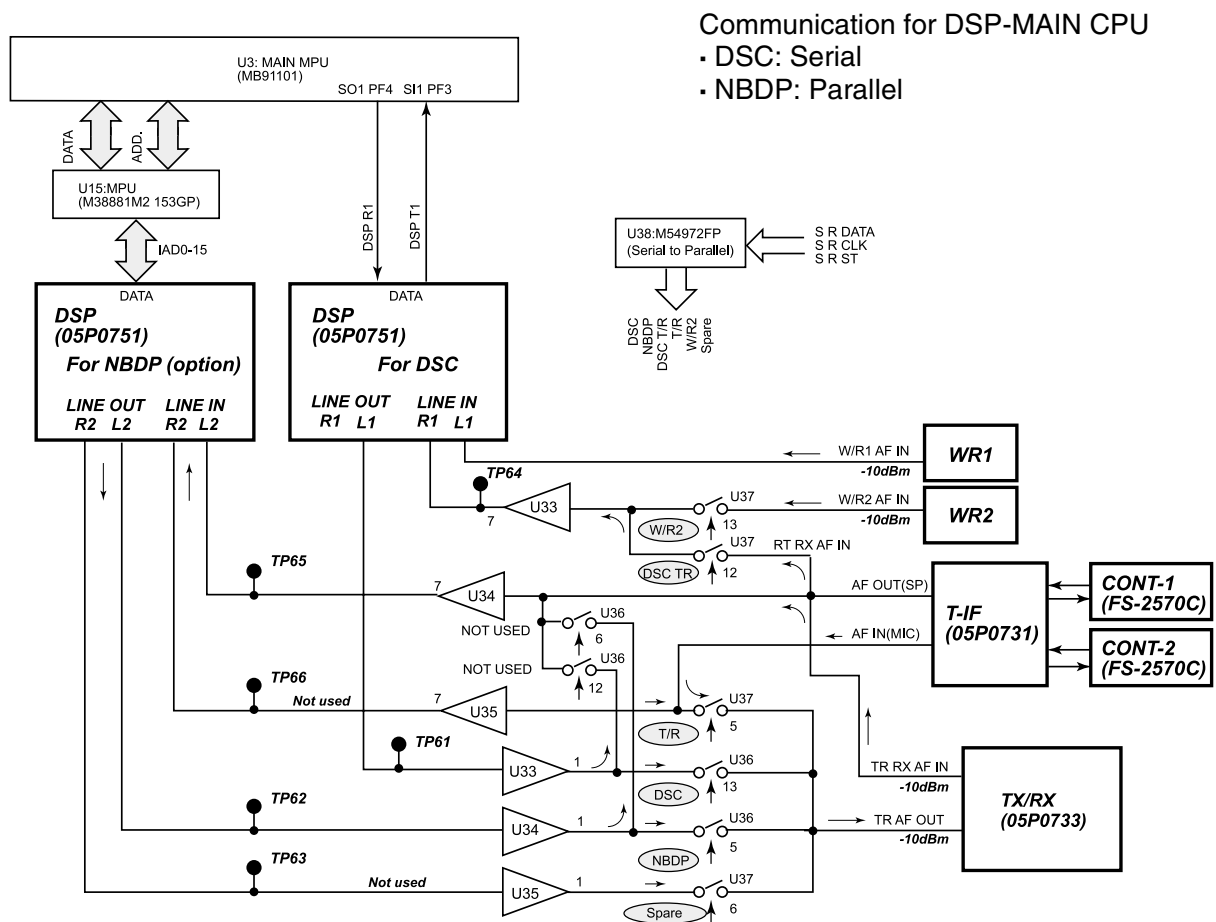

Fig.5.3.3 I/F circuit

5.3.5 Digital Signal Processor (DSP)

Fig.5.3.4 shows the DSP input/output circuits.

DSP (05P0751) board for NBDP and DSC are the same in hardware, but different in software. The LINE signals (AF) are switched by the analog switches. DSC distress and safety receiver (W/R 1) is directly connected to DSP board for continuous watch. The DSC general frequency signal is supplied to the DSP from either W/R 2 or TX/RX board depending on the presence of the INST signal from W/R 2 board. The MIC signal (AF-IN) from T-IF board is sent to TX/RX board through the analog switch T/R. The MIC signal connected to NBDP DSP is for future use.



Communication for DSP-MAIN CPU
 • DSC: Serial
 • NBDP: Parallel

Fig.5.3.4 DSP input/output circuit

5.4 TX/RX Board (05P0733)

5.4.1 Block diagram

Fig.5.4.1 shows the block diagram of TX/RX board (05P0733).

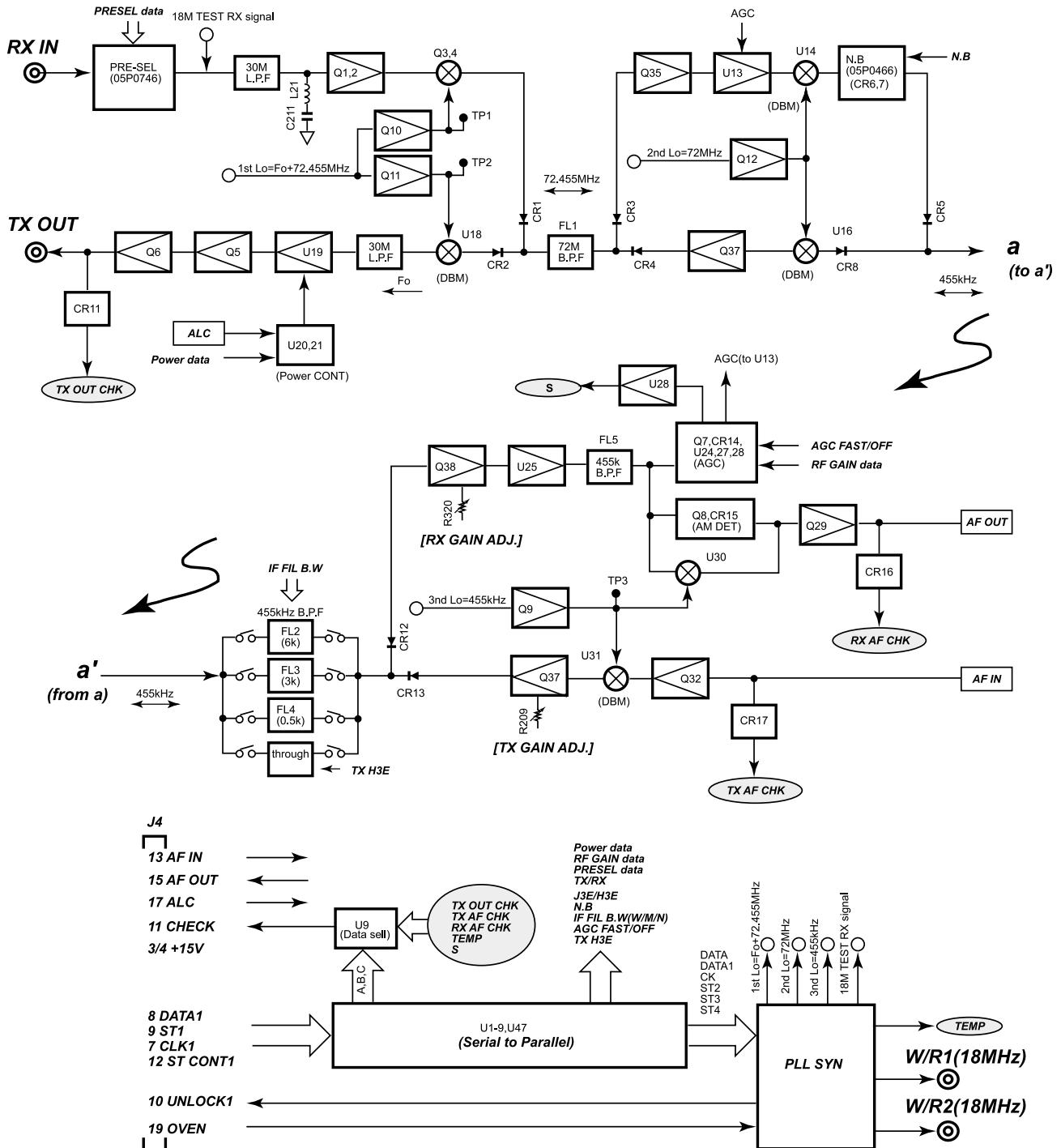

Fig.5.4.1 Block diagram of TX/RX board (05P0733)

5.4.2 Local oscillator

Fig.5.4.2 shows the block diagram of local oscillator on TX/RX board (05P0733).

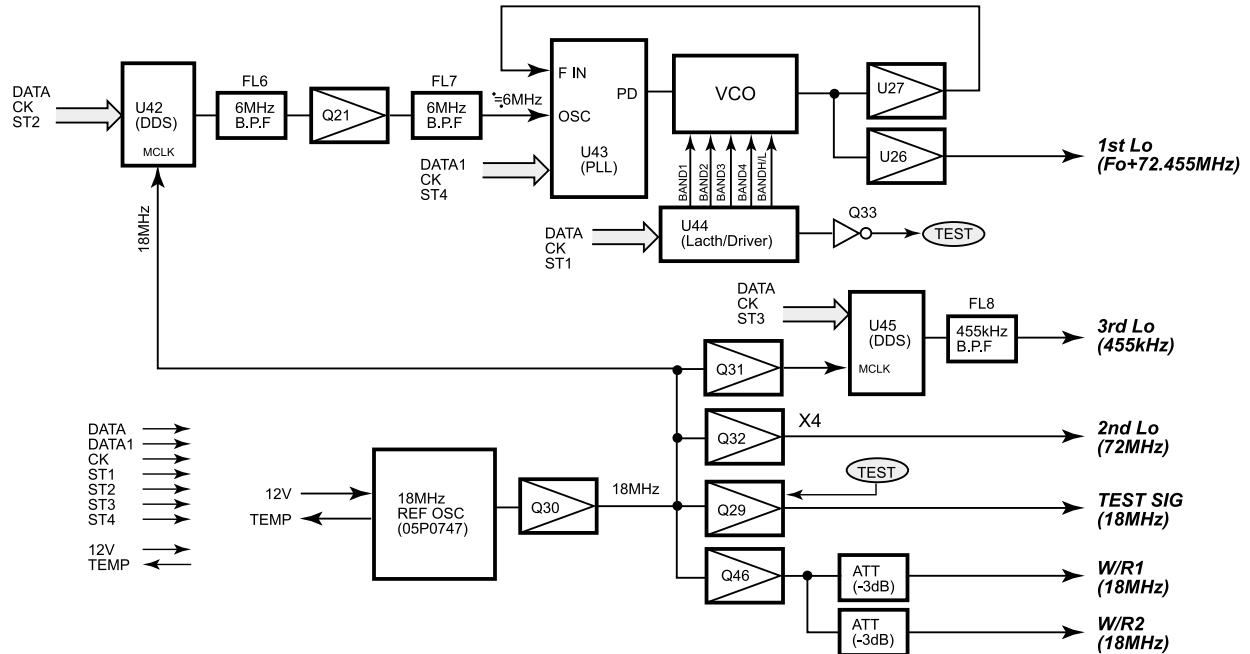

Fig.5.4.2 Block diagram of local oscillator

Reference oscillator

The local oscillator on TX/RX board uses 18 MHz reference signal generated by REF OSC board (05P0747). The reference signal is also used in PLL circuit on W/R board. Y1 is an oven-controlled crystal oscillator. The oscillation frequency is adjusted to 18 MHz \pm 5 Hz by the trimmer on Y1.

TEMP Signal

T-CPU board receives TEMP signal from REF OSC board to detect the oven temperature. When the temperature lowers to the designed one, no transmission is made, because the frequency deviates more than ± 10 Hz. The message, "OVEN COLD /TX NOT READY: WAIT" appears.

Oscillation frequency

First, second and third local oscillators generate $F+72.455$ MHz, 72 MHz and 455 kHz respectively. The 1st local oscillator consists of PLL and DDS circuits. The PLL circuit uses the output of the DDS circuit as a reference signal. The local oscillator frequency varies according to emission modes as shown in Table 5.4.1.

Table 5.4.1 Oscillation frequency of local oscillator

MODE		1st Lo	2nd Lo	3rd Lo
USB		$F+72.455$ MHz+1.5 kHz	72 MHz	456.5 kHz
LSB		$F+72.455$ MHz-1.5 kHz		453.5 kHz
H3E	Tx	$F+72.455$ MHz		456.5 kHz
	Rx			—
TLX				456.7 kHz
FAX				456.9 kHz

The PLL circuit includes four oscillation coils, T11, T12, T13 and T14 for 30 MHz frequency range. These coils are selected depending on frequency setting. Each oscillation circuit is used in lower and upper bands.

Table 5.4.2 PLL oscillation frequency

BAND	Oscillation coil	Setting frequency	VCO frequency
1-L	T11	0.1 to 2.99999MHz	72.55500 to 75.45499MHz
1-H		3.0 to 5.99999MHz	75.45500 to 78.45499MHz
2-L	T12	6.0 to 9.49999MHz	78.45500 to 81.94599MHz
2-H		9.5 to 13.49999MHz	81.95500 to 85.95499MHz
3-L	T13	13.5 to 17.49999MHz	85.95500 to 89.95499MHz
3-H		17.5 to 21.49999MHz	89.95500 to 93.95499MHz
4-L	T14	21.5 to 25.49999MHz	93.95500 to 97.95499MHz
4-H		25.5 to 29.99999MHz	97.95500 to 102.45499MHz

Offset frequency: 0 kHz(Mode:H3E, TLX, FAX)

SSB(USB) mode: add 1.5 kHz

5.4.3 Transmitter/Receiver circuit

AF circuit

The audio signal from the control unit is connected to TX/RX board via T-IF and T-CPU boards.

Main CPU on T-CPU board sends DSC and NBDP messages to DSP for AFSK (Audio Frequency Shift Keying) modulation or to generate 1700 Hz±85 Hz signal. The modulated DSC and NBDP signal is supplied to TX/RX board. For reception, the signal flows in reverse.

The AF signal or LINE IN and LINE OUT signals to and from TX/RX board is -10 dBm/600 Ω.

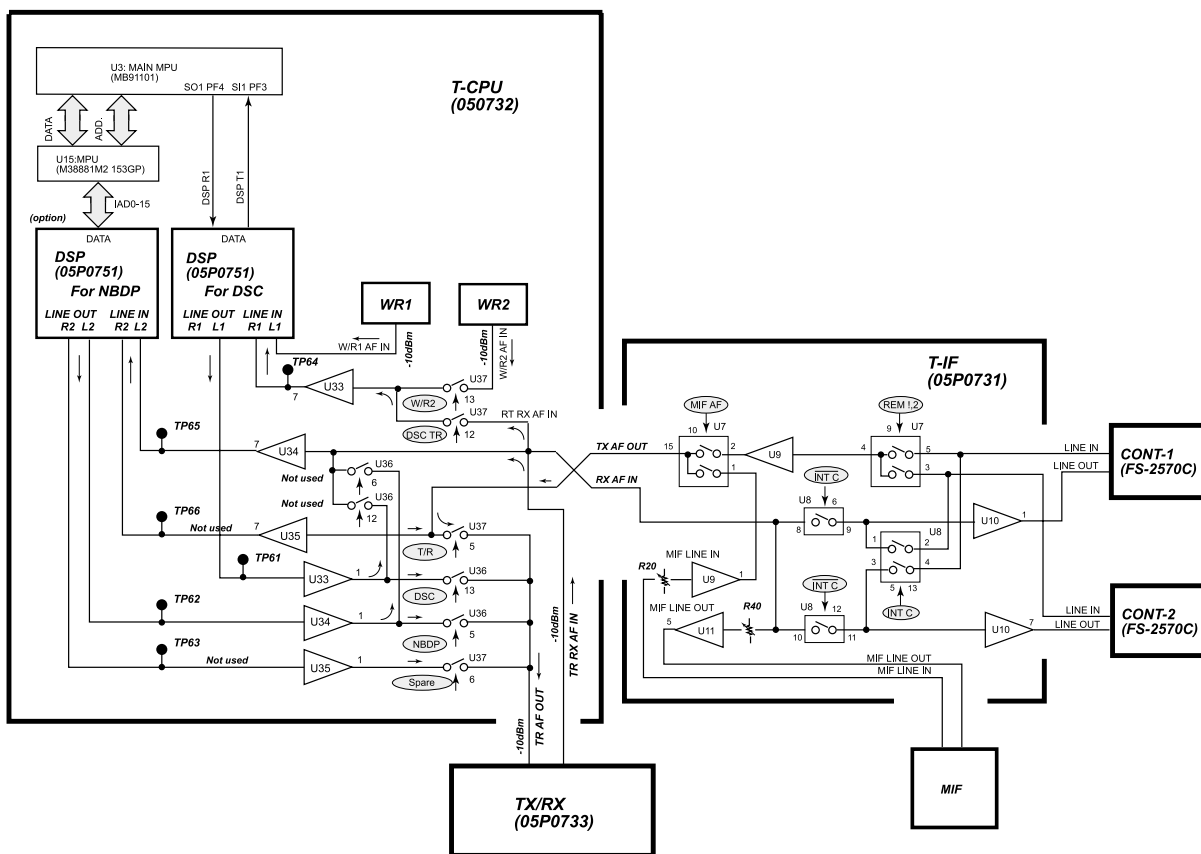

Fig.5.4.3 Block diagram of LINE IN/OUT circuit

Transmitting circuit

Fig.5.4.4 shows the block diagram of the transmitter on TX/RX board, 05P0733. AF IN signal is converted to RF signal, and then, output to PA circuit from TX OUT connector. The maximum output level is about +26 dBm (0.5 W)/50 Ω. R209, TX GAIN ADJ adjusts the output power from the transceiver unit. With microphone input of -55 dBm and power data of 240, the output from the transceiver unit is set to a quarter of the rated T/R output power. For example, the output power from the transceiver unit is set to about 40 W on 150 W radiotelephone. The rated T/R output power is adjusted by R76 (ALC) on TX FIL board. See chapter 7.

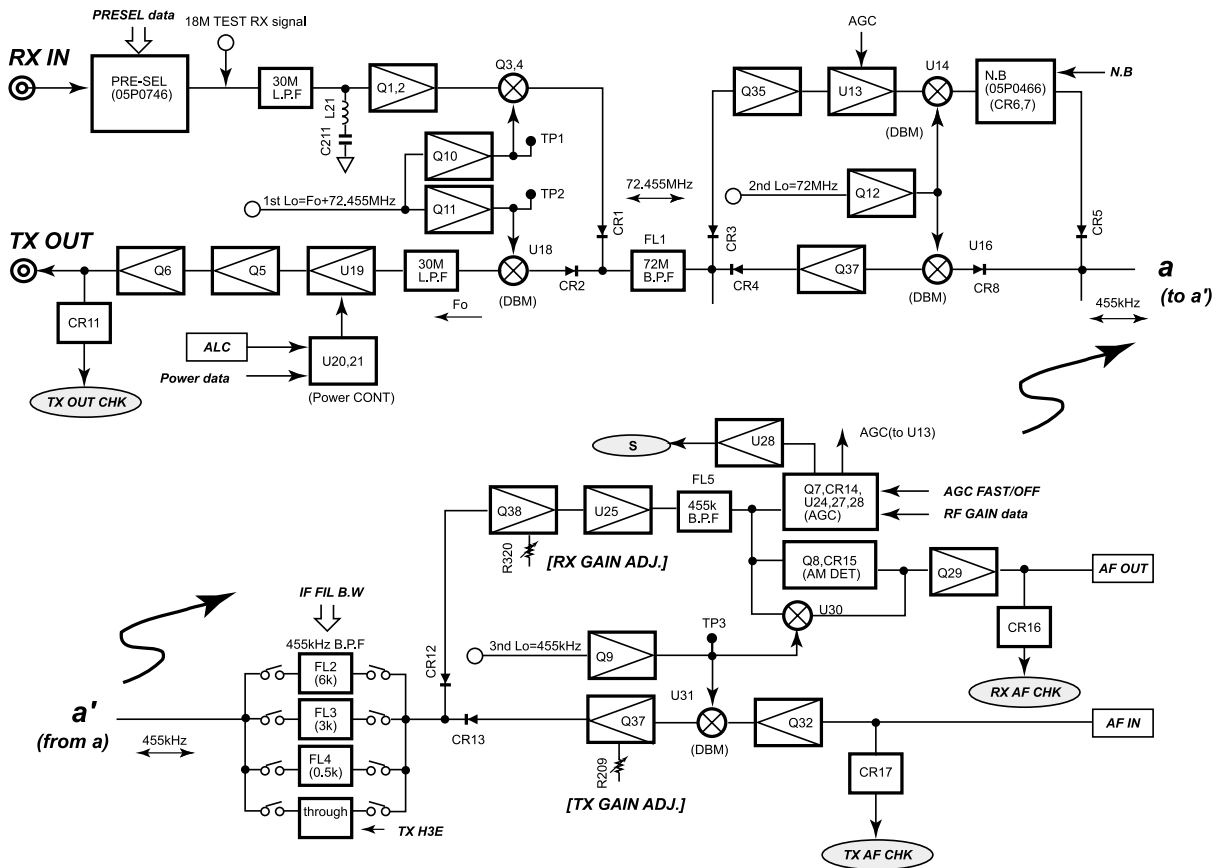

Fig.5.4.4 Block diagram of TX/RX board (05P0733)

In J3E mode, AF signal is frequency-converted to RF signal as shown in Table 5.4.3.

Table 5.4.3 Frequency converter and Transmitter IF frequency (J3E)

Frequency converter		Local frequency	IF signal
1st mixer	U31 (NJM1496V)	456.5 kHz (3rd Lo)	455 kHz
2nd mixer	U16 (NJM1496V)	72 MHz (2nd Lo)	72.455 MHz
3rd mixer	U18 (NJM1496V)	F0+72.455 kHz+1.5 MHz (3rd Lo)	F0+1.5 kHz

Power control circuit

U19, AD603AR is a variable-gain amplifier in power control circuit(ALC). The control signal is generated based on the power data and ALC signal from TX FIL board, and sent to pin1 (GPOS) of U19. The ALC signal decreases antenna output power to maintain the rated output power.

Check signal

TX OUT CHK signal is sent to T-CPU board. With the absence of TX OUT CHK signal, "RF" line in TX self-test result display is NG. TX AF CHK signal is not used.

Filter circuit

The received signal is input to PRESEL board (05P0746) to prevent signals at unwanted frequencies from getting through and optimize the selectivity of a receiver. PRESEL board includes four bandpass filters and a low-pass filter, insertion loss of 2 to 3 dB. 0.1 to 1.45 MHz signal passes through the low-pass filter. BPF2 allows signals at frequency range from 1.45 to 4.99 MHz to pass. BPF2 is made up of LC tuned circuits. Capacitors in BPF2 are selected by relays, receiving PR1 to PR6 data.

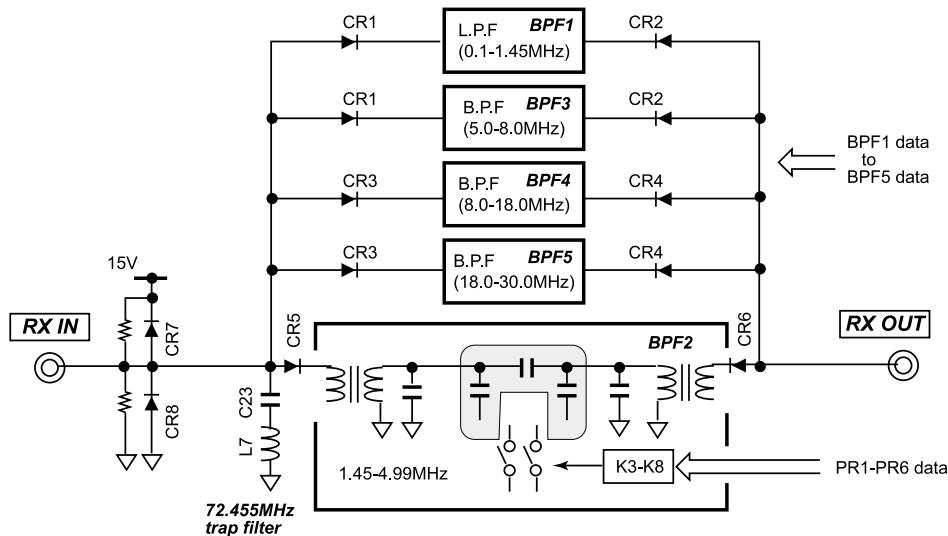
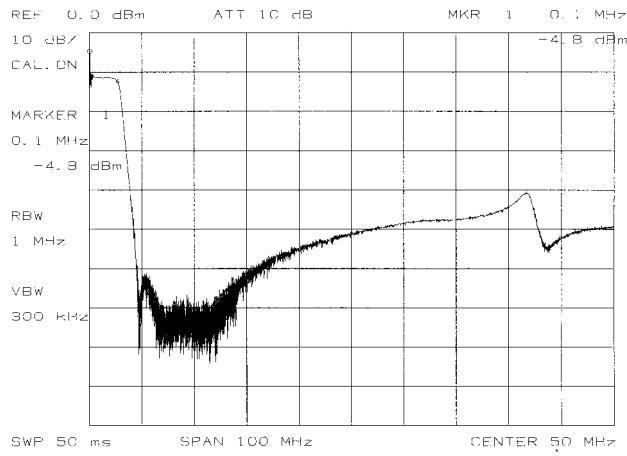

Fig.5.4.5 Block diagram of PRESEL Board (05P0746)

BPF2 tunes the signal at frequency bands tabulated in Table 5.4.4. CR7 and CR8 is a receiver protector which protects receiver front-end circuits from damage when an input signal of 15 Vp-p or more is present. C23 and L7 is a 72.455 kHz trap circuit which allows IF signal not to leak from the antenna.

Table 5.4.4 Tune circuits in BPF2

Tuning frequencies(MHz)					
1.45 to 1.49999	1.8 to 1.84999	2.15 to 2.19999	2.5 to 2.54999	3.1 to 3.19999	4.3 to 4.59999
1.5 to 1.54999	1.85 to 1.89999	2.2 to 2.24999	2.55 to 2.5999	3.2 to 3.29999	4.6 to 4.99999
1.55 to 1.59999	1.9 to 1.94999	2.25 to 2.29999	2.6 to 2.69999	3.3 to 3.39999	
1.6 to 1.64999	1.95 to 1.99999	2.3 to 2.34999	2.7 to 2.79999	3.4 to 3.59999	
1.65 to 1.69999	2.0 to 2.04999	2.35 to 2.39999	2.8 to 2.89999	3.6 to 3.79999	
1.7 to 1.74999	2.05 to 2.09999	2.4 to 2.44999	2.9 to 2.99999	3.8 to 3.99999	
1.75 to 1.79999	2.1 to 2.14999	2.45 to 2.49999	3.0 to 3.09999	4.0 to 4.29999	



B.P.F -1: 0.1-1.45MHz

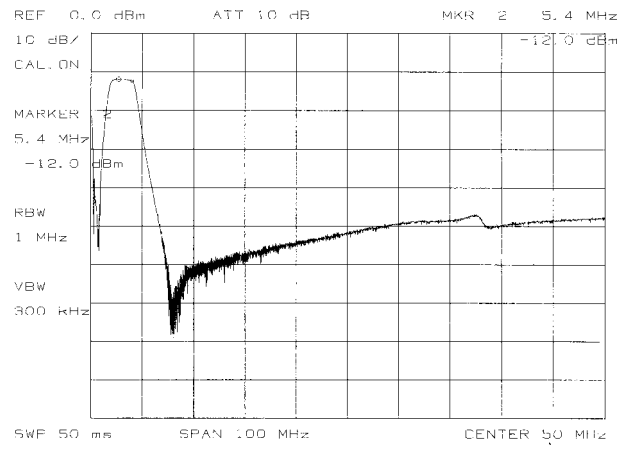

B.P.F -3: 5.0-8.0MHz

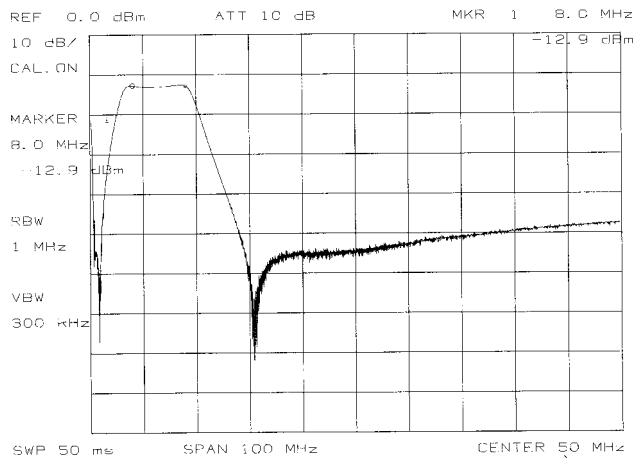

B.P.F -4: 8.0-18MHz

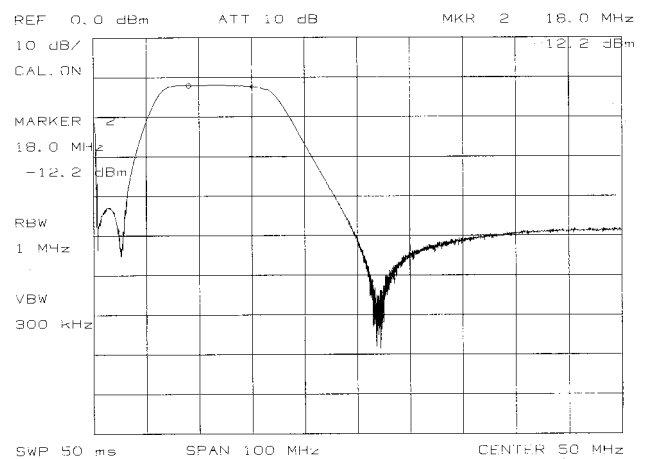

B.P.F -5: 18-30MHz

Fig.5.4.6 Characteristic of B.P.F

The receiver sensitivity from RX IN connector on TX/RX board to AF output terminal on the control unit is;

- 1) SINAD 20dB
 - J3E: +3 dBuV
 - H3E: +18 dBuV

- 2) AF output(SP) 4W
 - 0±3dBuV

- 3) Minimum AGC level (Minimum AGC operating level is the same level as that S meter starts defecting.)
 - +12 dBuV
 - Reference)
 - AGC attack-time: 8.6 msec
 - AGC decay-time: 1080 msec

5.5 Power Amplifier (PA)

5.5.1 FS-1570T PA board (05P0735)

The amplifier circuit on PA board consists of drivers, Q1 and Q2 and push-pull amplifiers Q3 and Q4. The gain is about 27 dB. 0.3 W (about 10 Vp-p) RF signal from TX/RX board is boosted up to about 150 W.

PA bias current is adjusted to 200 mA by R25. When measuring the current, the ammeter is placed in series to L4 in PA Vc circuit.

The driver bias current is about 30 to 40 mA. No adjuster is provided. To check the bias current, measure the voltage across R27 (0.22 Ω) and use formula, $I_{BIAS} = V_{R27} / 0.22$.

The ground of PA board is isolated by C39, C40 and C50 from chassis ground. When measuring voltage, use the ground on PA board.

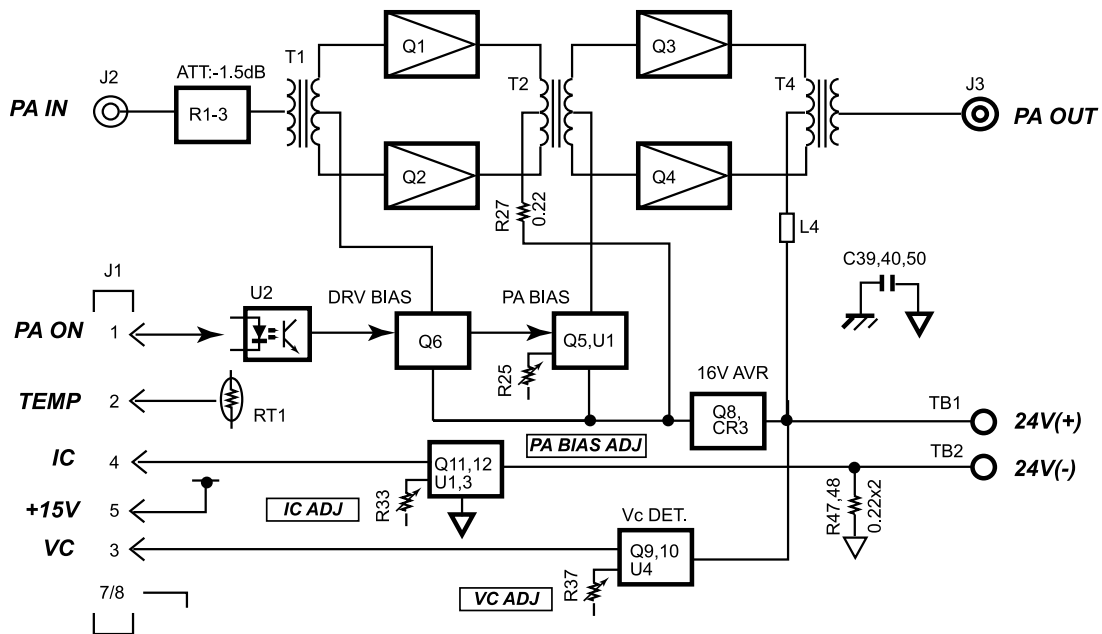

Fig.5.5.1 Block diagram of FS-1570 PA board

VC and IC signals

PA collector voltage (VC) is adjusted by R37. The VC detector detects the voltage and sends it to TX FIL board. VC is displayed numerically in Power SET UP menu. PA collector current (IC) is adjusted by R33. The current is detected by R47 and R48 and displayed in Power SETUP menu as "IC".

TEMP signal

The thermistor RT1 detects the temperature of power amplifier. When the temperature increases up to about 80 °C, "TX POW REDUCED MAIN AMP HEATED" appears and the power is reduced automatically.

PA ON signal

PA ON signal switches on/off the DRV and PA bias circuits on PA board.

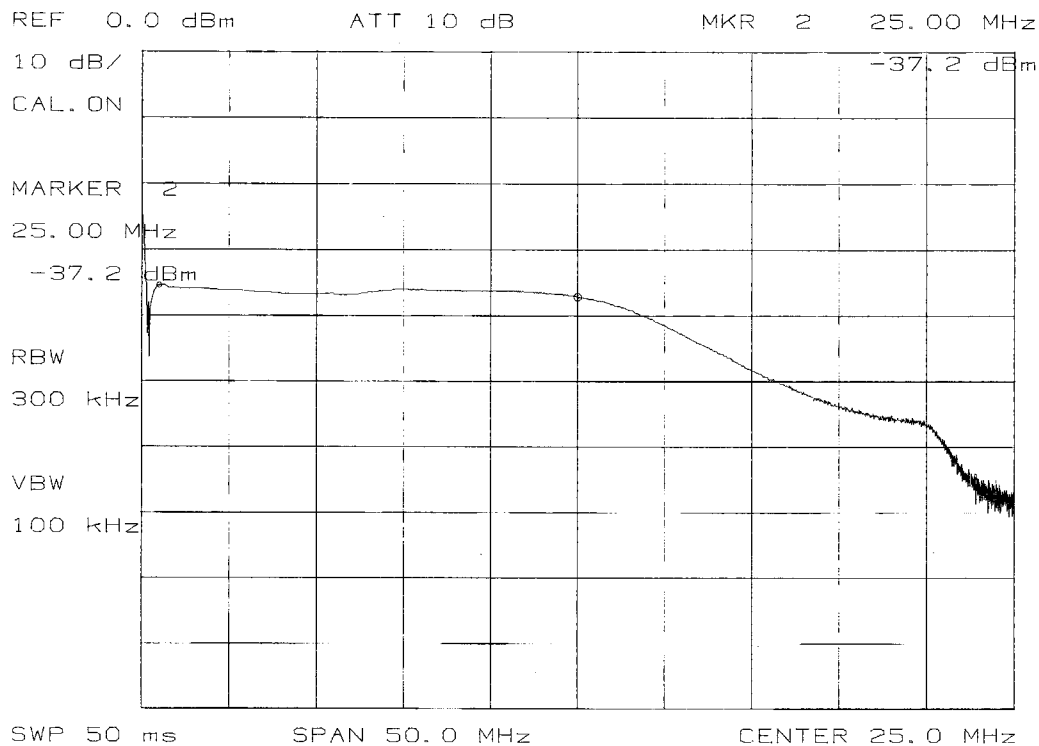

Fig.5.5.2 PA frequency characteristic of FS-1570

5.5.2 FS-2570T DRV board (05P0738)

The amplifier circuit on DRV board consists of drivers, Q1 and Q2 and PA push-pull amplifiers, Q3 and Q4 and power distribution circuits, T5. The gain is about 20 dB. 0.3 W (about 10 Vp-p) RF signal from TX/RX board is boosted up and then divided by T5. The output is about 15 W at “RF OUT-1” and “RF OUT-2”.

PA bias current is adjusted to 100 mA by R25. When measuring the current, the ammeter is placed in series to L4 in PA Vc circuit.

The output of T4 is connected to PA bias control circuit, Q9, CR2 and CR4. Q9 turns on with the T/R output power of 60 to 70 W and appropriate PA bias is selected to reduce intermodulation distortion (IMD). The driver bias is about 30 to 40 mA. To check the bias current, measure the voltage across R32 (0.22 Ω) and use formula, $I_{BIAS} = V_{R32} / 0.22$.

The ground of PA board is isolated by C32 and C33 from chassis ground. When measuring voltage, use the ground on DRV board.

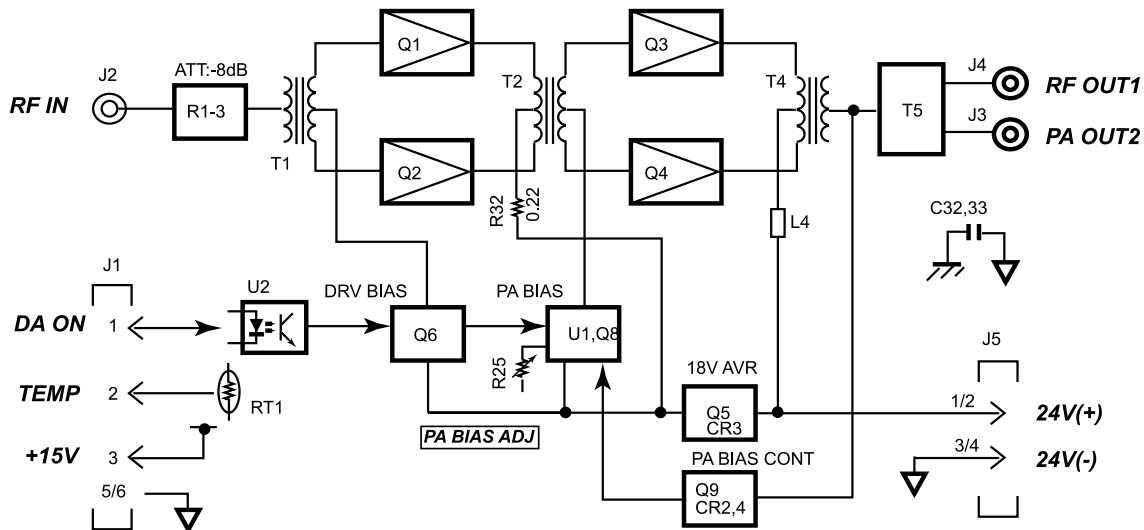

Fig.5.5.3 Block diagram of FS-2570 DRV board

TEMP Signal

The thermistor RT1 detects the PA temperature. Data is not used.

DA ON Signal

DA ON signal switches on/off the bias circuit on DRV board.

5.5.3 FS-2570T PA board (05P0739)

The amplifier circuit on PA board consists of push-pull circuits, Q1 and Q2. The gain is about 10 dB. 15 W RF signal from DRV board is boosted up about 150 W.

PA bias current is adjusted to 200 mA by R16. When measuring the current, the ammeter is placed in series to L1 in PA Vc circuit.

The ground of PA board is isolated by C30 and C31 from chassis ground. When measuring voltage, use the ground on PA board.

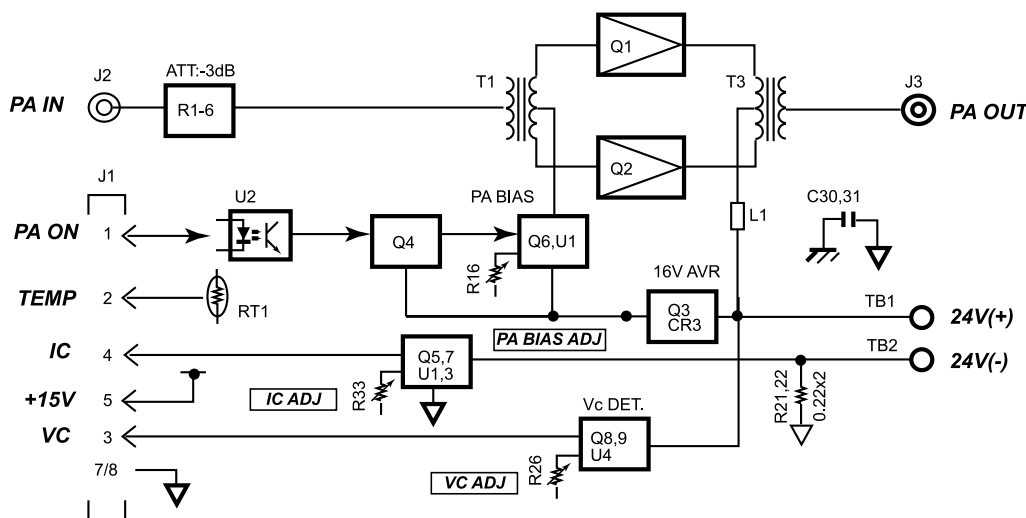

Fig.5.5.4 Block diagram of FS-2570 PA board

VC and IC Signals

PA collector voltage (VC) is adjusted by R26. The VC detector consisting of U4, Q8 and Q9 sends VC to TX FIL board. VC is displayed numerically in Power SET UP menu. The displayed VC is the one detected on PA-1 board. PA collector current (IC) is adjusted by R33. The current is detected by R21 and R22 and displayed in Power SETUP menu as "IC". The displayed IC is the sum of Ics on PA-1 and PA-2 board.

TEMP Signal

The thermistor RT1 detects the temperature of power amplifier. When the temperature increases up to about 80 °C, "TX POW REDUCED MAIN AMP HEATED" appears and the power is reduced automatically.

PA ON Signal

PA ON signal switches on/off the bias circuit on PA board.

5.5.4 FS-2570T COMB board (05P0740)

This board combines the outputs from two identical PA boards to obtain 250 W. The output impedance of PA is 50 ohms. The same current flows in primary and secondary windings of T1 in opposite direction so the magnetic fluxes are cancelled. No current flows through R1 when PA outputs are the same.

T1 works as 4:1 impedance converter that is the impedance of the secondary winding is 25 ohms.

T2 converts the impedance from 25 ohms to 50 ohms. The output from COMB board is connected to TX FIL board.

CHECK signal is used to indicate the test result of COMB board.

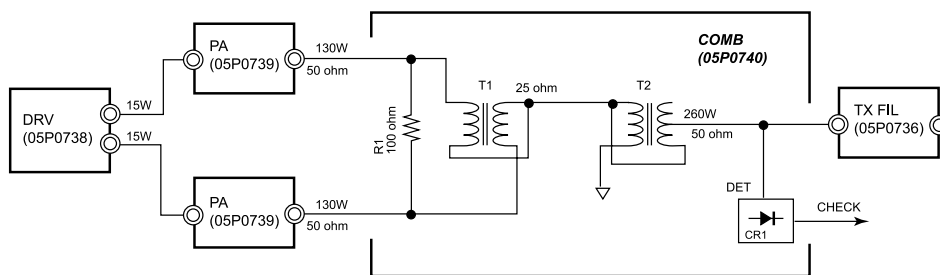

Fig.5.5.5 Block diagram of FS-2570 COMB Board

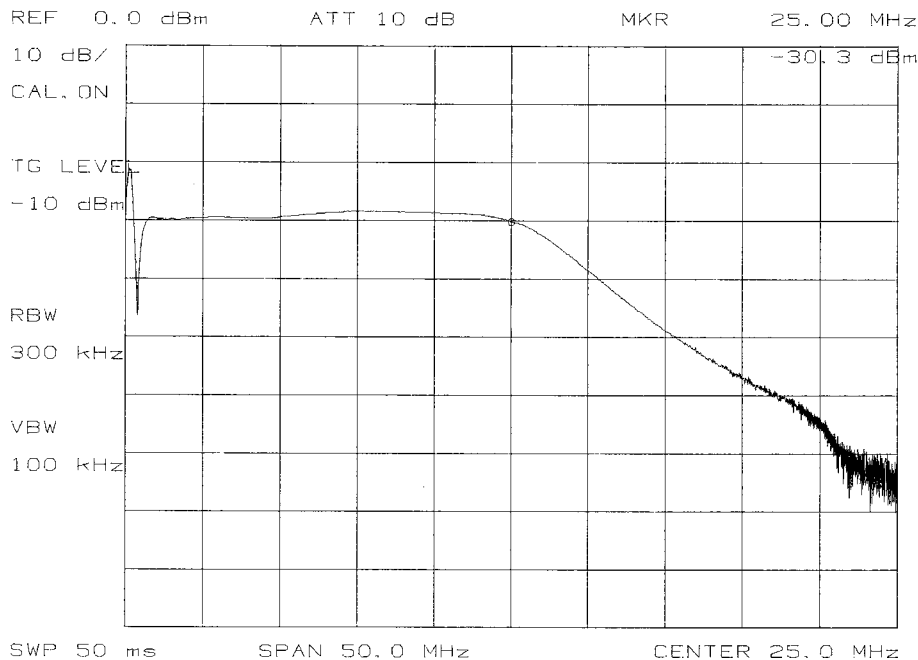

Fig.5.5.6 Frequency characteristic of DRV, PA and COMB boards

5.5.5 TX FIL board (05P0736)

The TX FIL board, consisting of L.P.Fs, eliminates and suppresses the higher harmonics included in the signal from PA board. The insertion loss is -0.5 dB or less.

T1 and T2, placed in the input and output circuits of the L.P.F, are VSWR detectors. At self-test, the CPU decides that TX FIL board is normal if detectors detect the forward signal. The signal detected by T2 is also used to generate Automatic Level Control (ALC) signal. The ALC signal is sent to "POWER CONT" circuit on TX/RX board. The T-CPU does not use ALC signal received. R76 adjusts output power.

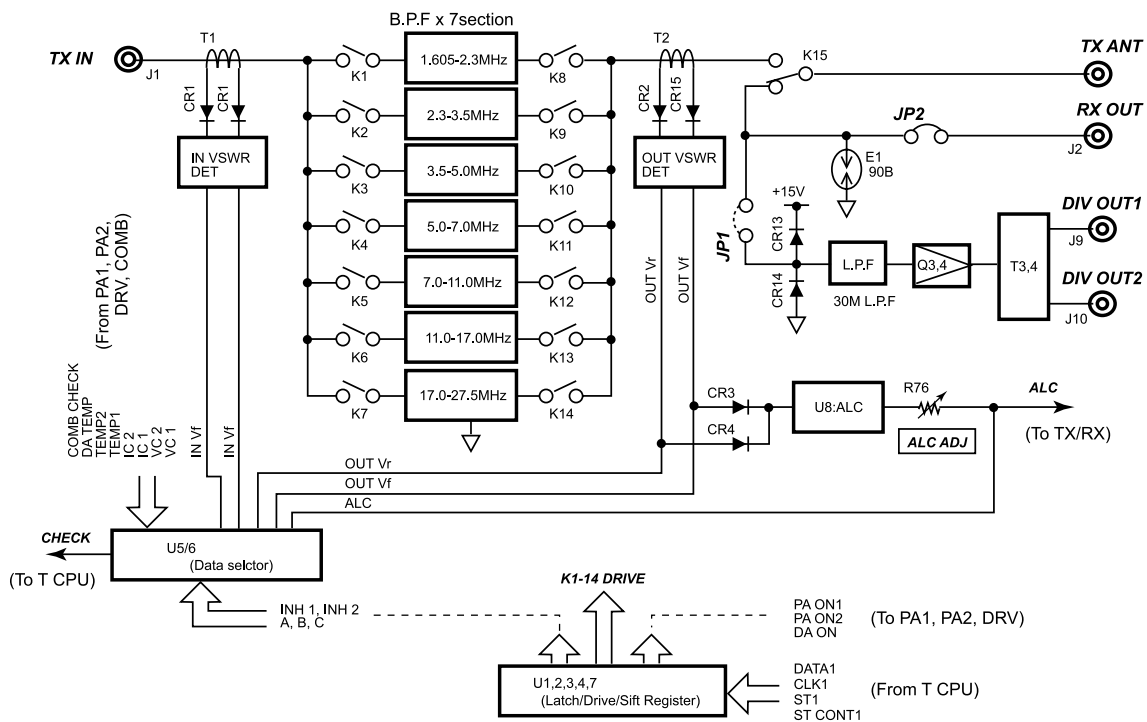

Fig.5.5.7 Block diagram of TX FIL board

Receiving circuit

The signal received by the antenna is delivered to TX ANT connector via the antenna coupler, and then PRESEL board from RX ANT connector via 50 ohm BK relay, K15.

When DSC general frequencies receiver board uses the TX/RX antenna, JP2 is set to “open” and JP1 to “short”.

The received signal is amplified by Q3 and Q4, and applied to DIV OUT 1 and DIV OUT 2 ports via T3 and T4. The OUT 1 and OUT 2 are connected to PRESEL and W/R 2 boards respectively. The signal at DIV OUT ports is 3 dB or more higher than RX OUT port.

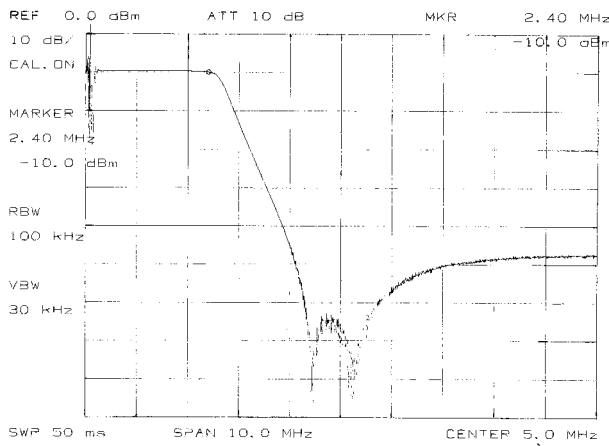

BAND-1: 1.6-2.3 M

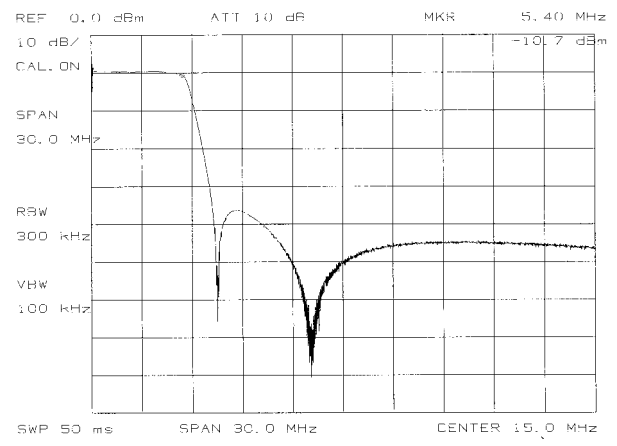

BAND-3: 3.5-5.0 M

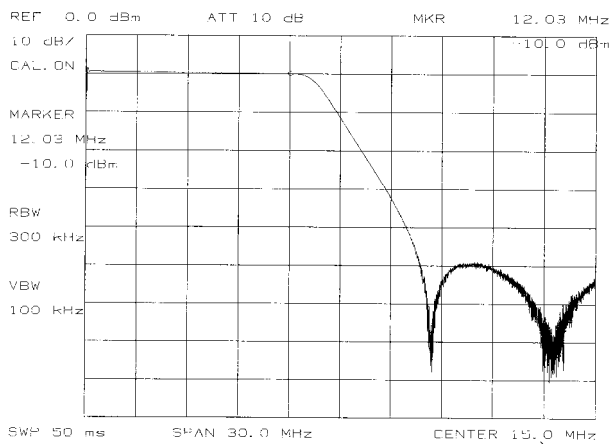

BAND-5: 7.0-11.0 M

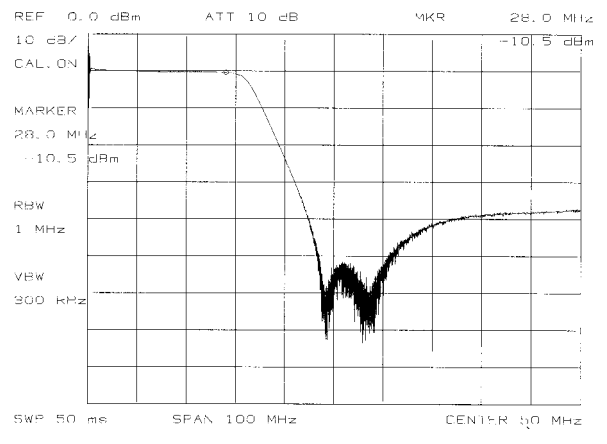

BAND-7: 17.0-27.5 M

Fig.5.5.8 Frequency characteristics on TX FIL Board

5.6 W/R board (05P0734)

W/R board (05P0734) is a DSC receiver board: W/R 1 is a DSC distress and safety frequencies receiver board and W/R 2 DSC general frequencies receiver board. Both are identical.

The W/R board consists of RF amplifier, DSC signal demodulator and PLL synthesizer local oscillator. The 18 MHz reference signal used in the PLL circuit is generated by REF OSC board. The frequency error of AFSK signal, $1700 \text{ Hz} \pm 85 \text{ Hz}$ is within $\pm 10 \text{ Hz}$.

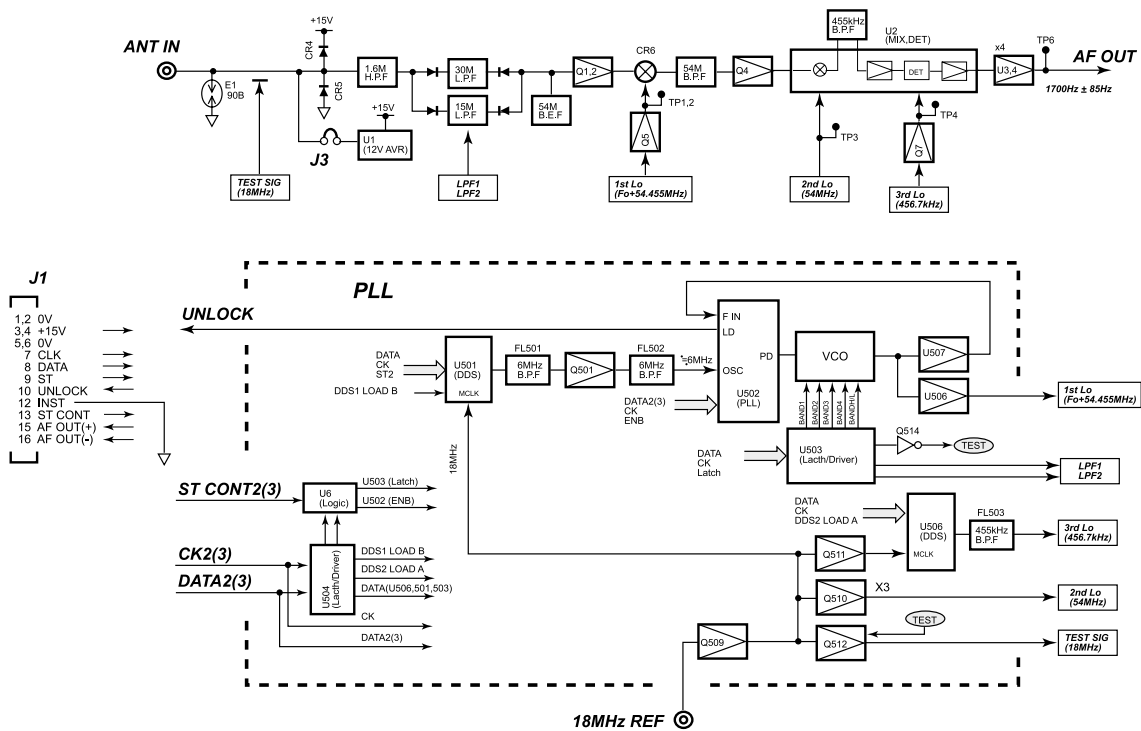

Fig.5.6.1 Block diagram of W/R board

Specification of W/R board

Antenna impedance: 50 Ω

Receiver type: Double super heterodyne

Receiver sensitivity: Character error rate is 1 % or less with receiver input voltage of 1 μV.

Local oscillator: 1st: F+54455 kHz; 2nd: 54000 kHz; 3rd: 456.7 kHz

Intermediate frequency: 1st IF: 54455 kHz; 2nd IF: 455 kHz

Output level: -10 dBm/600 Ω

Scanning reception: 6 channels (max.) within 2 seconds

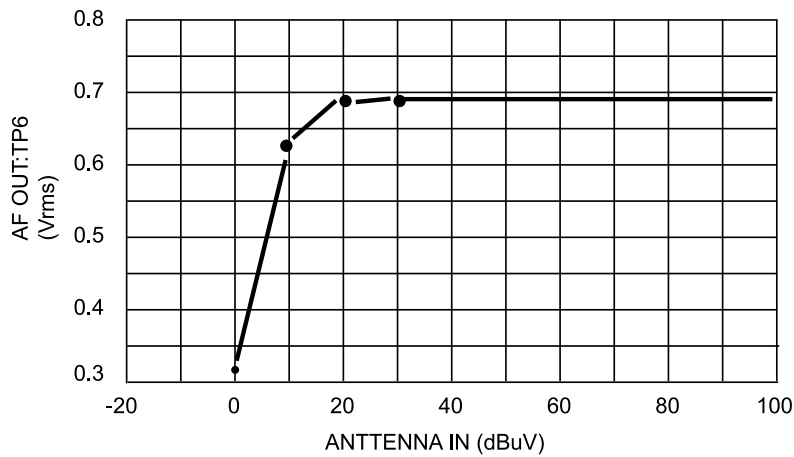

Fig.5.6.2 Input vs. output on W/R Board

PLL circuit

The PLL circuit consisting of DDS and PLL, operates with the reference signal of 18 MHz from REF OSC board.

The PLL oscillates at the frequency range from 56.0615 to 81.955 MHz, using four oscillation coils, T501 to T504. The oscillation frequency depends on the frequency setting. BAND H/L signal selects the VCO circuit for the lower or higher frequency range in each band.

Table 5.6.1 PLL oscillation frequencies

BAND	Setting frequency (MHz)	Oscillation frequency (MHz)
1-L	1.6065 to 2.99999	56.06150 to 57.45499
1-H	3.0 to 5.99999	57.45500 to 60.45499
2-L	6.0 to 9.49999	60.45500 to 63.95499
2-H	9.5 to 13.49999	63.95500 to 67.95499
3-L	13.5 to 17.49999	67.95500 to 71.95499
3-H	17.5 to 21.49999	71.95500 to 75.95499
4-L	21.5 to 25.49999	75.95500 to 79.95499
4-H	25.5 to 27.50000	79.95500 to 81.95500

Receiver circuit

The receiver is protected by an arrester, CR4 and CR5 from 30 Vrms signal being applied for more than 15 minutes.

When the preamplifier FAX-5 is used, jumper block J3 is put between #1 and #2 to supply +12V to the preamplifier.

INST Signal

The T-CPU recognizes the presence of the W/R 2 board by receiving INST signal. Table 5.6.2 lists DSC operation with and without W/R 2 board.

Table 5.6.2 Functions with and without W/R2

W/R 2	INST signal	DSC scan	DSC ACK reception	DSC self-test result display
Mounted	Yes	W/R2 board	W/R2 board	RECV-2: OK/NG
Not mounted	No	TX/RX board	TX/RX board	Blank

Self test

18 MHz test signal, modulated by mark and space signals, is applied to ANT IN line. The stray capacitance between traces on the board couples the test signal. The level is equal to SSG output of 70 to 80 dBuV. The receiver on DSC DSP board is also tested by this signal.

Monitor sound of DSC signal

When the dot pattern is detected regardless of the call type, "IN COMING" appears in the display. Then, AF MUTE signal is set to OFF to output the DSC receiving sound from the loudspeaker. If the call is failed to receive or the unrelated call to the own station is sent, the DSC receiving sound is set to MUTE.

DSC DSP always checks DSC signal.

Synchronization to DSC signal

Recognition of DSC signal: BY 5 bit dot pattern

Synchronization to DSC signal: The synchronization starts by receiving one of the following synchronizing sequence signal patterns.

- 2 DX signals and 1 RX signal
- 1 DX signal and 2 RX signals
- 3 RX signals

5.7 C-CPU Board (05P0729)/C-IF Board (05P0730)

Fig.5.7.1 shows the block diagram of control unit, FS-2570C.

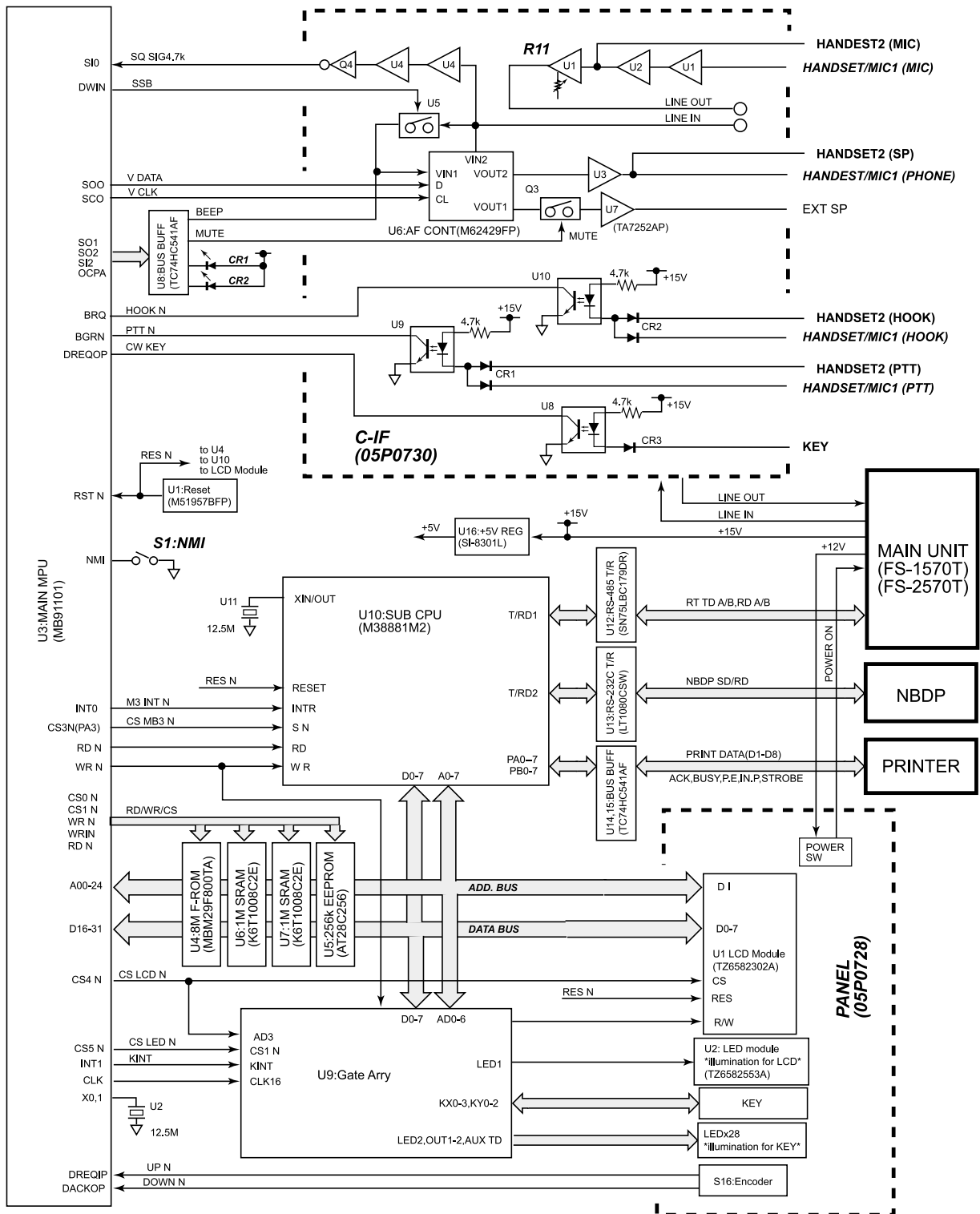

Fig.5.7.1 Block diagram of Control unit, FS-2570C

5.7.1 C-CPU Board (05P0729)

1. CPU

32 bit Main CPU and 8 bit CPU locate on C-CPU board.

Table 5.7.1 C-CPU

MAIN CPU (U3, MB91101)	SUB CPU (U10, M38881M2)	Gate Array (U9, LZ9GF18)
Heart of the control unit	Used to expand serial ports of Main CPU (For NBDP and T-CPU connection)	Controls key input, display and brilliance.

2. Memory

Table 5.7.2 lists the memories on C-CPU board.

Table 5.7.2 Memories

8 Mbit Flash ROM (U4, MBM29F800TA)	256 kbit EEPROM (U5, AT28C256)	1 Mbit SRAM (U6 and U7, K6T1008C2E)
FS-2570C program is stored.	Backup of contrast/dimmer, and AF/RF volume and SQ settings	Used by C-CPU as working memory

3. LED

CR1 and CR2 are not used. These are normally on.

4. NMI SW

Not used.

5.7.2 C-IF Board (05P0730)

C-IF board consists of microphone amplifier, audio control circuit, AF amplifier and PTT and HOOK signal detectors. The board receives AF signal, -10 dBm/600 Ω from the transceiver unit as “LINE IN” signal. U6 sets AF output level to the loudspeaker. The AF signal or LINE IN signal is also input to U3 on C-CPU board as SQ SIG. This signal is used to generate MUTE signal according to SQ FRQ setting in system setting menu. The MUTE signal controls external speaker (EXT SP). The AF line of the handset is not controlled by SQ signal.

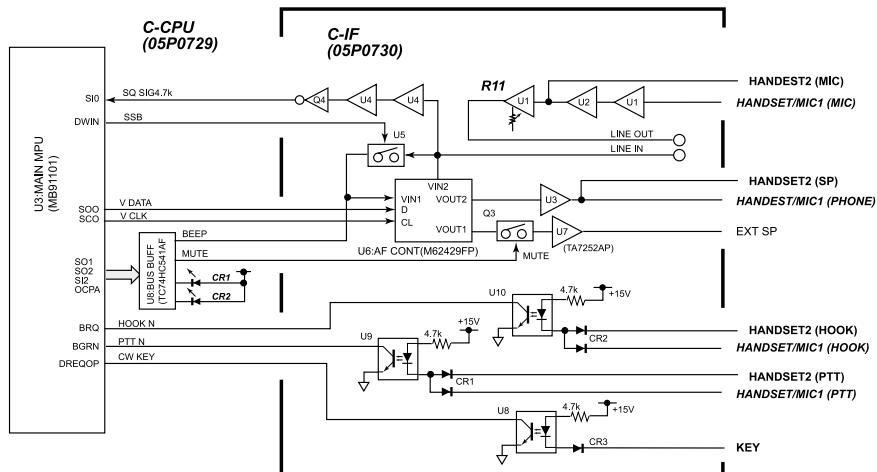

Fig.5.7.2 Block diagram of C-IF board

Table 5.7.3 Input/output level

Port	Input/output level of C-IF board			Remarks
		Input	Output	
HANDSET	MIC	-10 dBm/600Ω	-10 dBm/600Ω	For the condenser microphone, HS2001
	SP	-10 dBm/600Ω	-10 dBm/600Ω (Ear SP:2.5mW/150Ω)	
HANDSET /MIC	MIC	-46 dBm/600 Ω	-10 dBm/600 Ω	For the dynamic microphone, HSC-701K-20B
	SP	-10 dBm/600Ω	Ear SP:2.5mW/200Ω	

Note)

The control unit provides two handset connection ports, [HANDSET]: HS2001 and [HANDSET/MIC]: HSC-701K-20B. Do not use these ports at a time. Hook and PTT lines on two handsets are connected in parallel.

HOOK signal

OFF HOOK signal is generated when the handset is off-hook. With OFF HOOK signal;

- 1) DSC AUTO ACK function does not work.
- 2) “Occupied Another Controller” message appears on the other control unit. No.1 control unit can be used with this message, but No.2 control unit cannot.

KEY signal

Not used.

5.7.3 Handset

The standard handset for FS-1570/FS-2570 is a condenser microphone HS-2001 with amplifiers which amplify $-43 \text{ dBm}/2 \text{ k}\Omega$ signal to $-10 \text{ dBm}/600 \Omega$. SP signal of $-10 \text{ dBm}/600 \Omega$ is also amplified to $2.5 \text{ mW}/150 \Omega$.

Hall IC, U5 detects Hook signal.

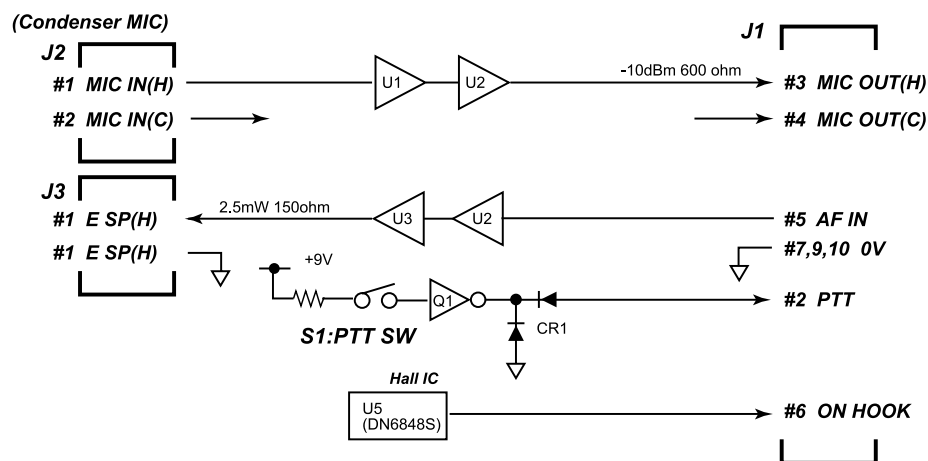

Fig.5.7.3 Block diagram of Handset, HS-2001

5.8 Antenna coupler, AT-1560

Fig.5.8.1 shows the block diagram of COUP board in antenna coupler, AT-1560. There are two antenna couplers as shown in Table 5.8.1.

Table 5.8.1 Comparison between Antenna couplers

	AT-1560-15	AT-1560-25	Remarks
Used by	FS-1570	FS-2570/FS-1570	
Input power	150W	250W	
Dummy load	10Ω+250P (100W)	10Ω+250P (200W)	
Dummy board	05P0543	05P0610	Antenna is grounded through this board when power is off.
COUP board	05P0528	05P0528A	In AT-1560-25, L8 and L9 are switched by a reed relay.

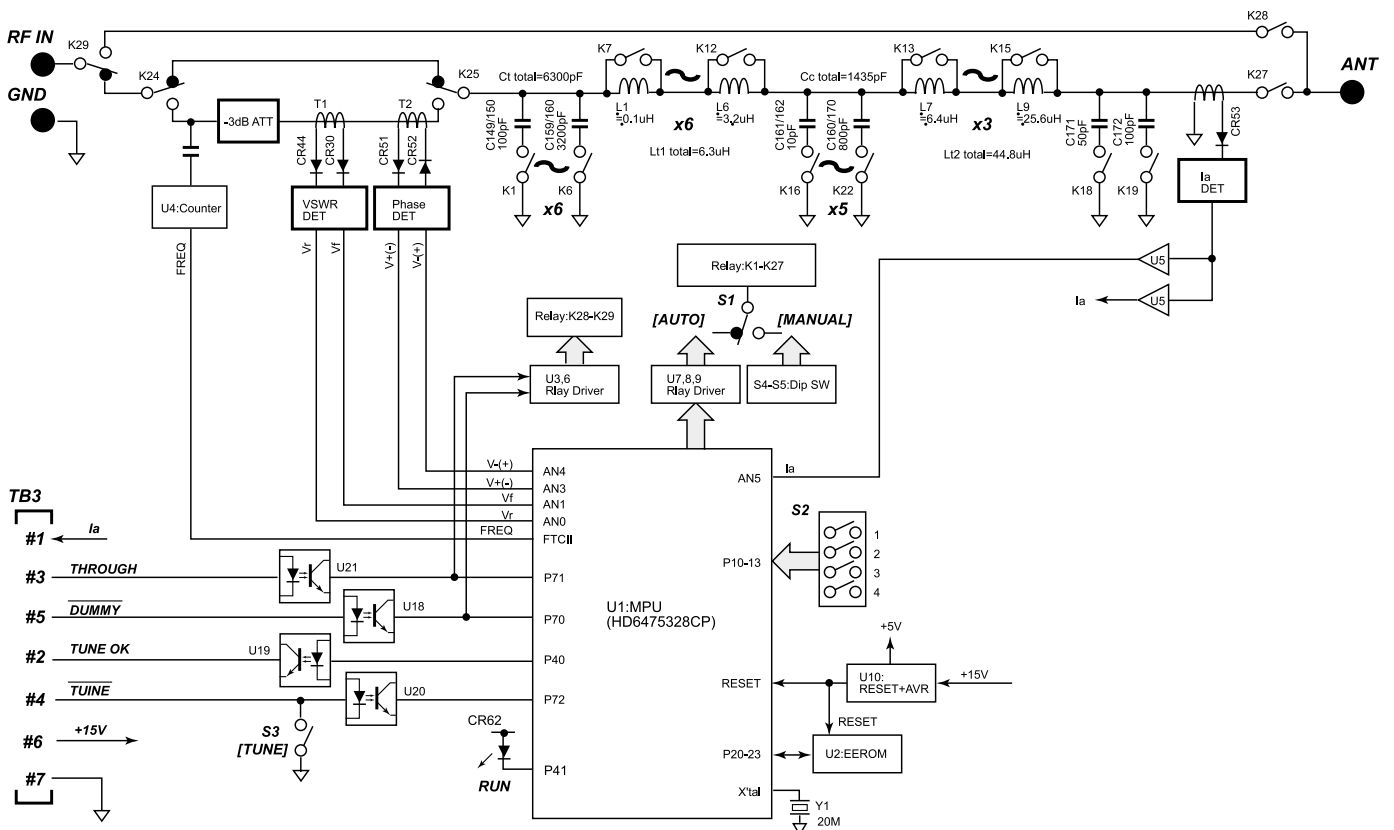

Fig.5.8.1 Block diagram of COUP board (05P0528)

Timing of control signal

Tuning is made by receiving “TUNE” signal. Fig.5.8.2 is the timing chart for generating TUNE OK signal. When tuning is made successfully, TUNE OK (H) signal is generated. If not, TUNE ERROR (L) signal is generated. Pressing TUNE switch, S3 also tunes the antenna matching circuit.

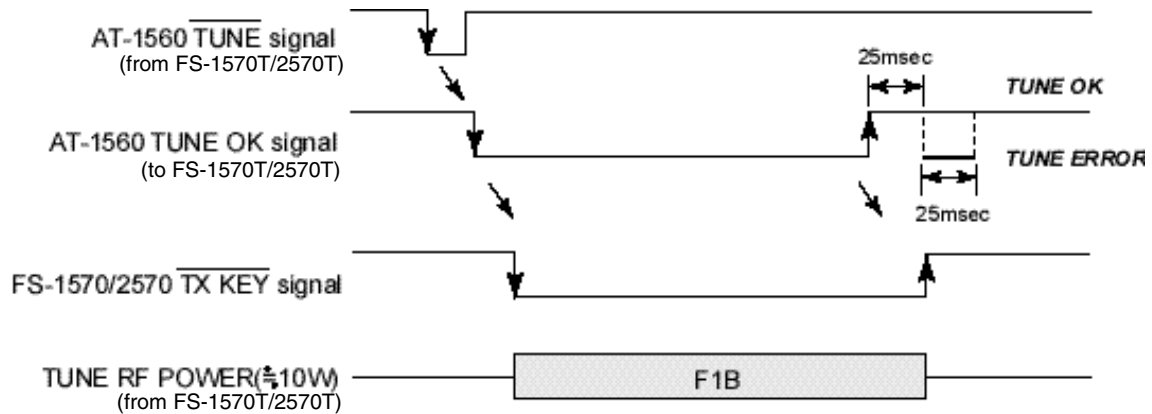

Fig.5.8.2 Timing of control signals

TROUGH signal

“Through signal” is used to decide whether the receiving signal bypasses the antenna matching circuit or not.

When COUPLER THROU in the RT system setting menu is set to “DIFF”, and the transmission frequency and the receiving frequency are different, the receiving signal bypasses the tuning circuit;

- 1) If the receiving frequency is 1.6 MHz or less.
- 2) If the receiving frequency is less than 4 MHz and different from the transmission frequency.
- 3) If the receiving frequency is 4 MHz or more and different 1.2 MHz from the transmission frequency.
- 4) During the RT scanning.

Generally, when the transmission frequency and the receiving frequency are different, the receiving signal does not pass through the matching circuit so that the signal is not attenuated.

Self-test

See Chapter 5.

Matching circuit

The following signals control the antenna matching circuit. Either gamma or pi matching circuit is selected.

- **FREQ signal (U4, Counter)**
U4 measures the frequency of the input signal to the matching circuit which tunes 1.6 MHz to 30 MHz signal. The frequency data is also used to store the matching data.
- **Vr and Vf (T1, VSWR detector)**
Forward power (Vf) and return power (Vr) are used to calculate VSWR. The matching circuit of the minimum VSWR is selected.
- **V+ and V- (T2, Phase detector)**
The phase sensor detects the phase of antenna impedance, capacitive or inductive reactance of an impedance matching network.
- **Ia (T3, Ia detector)**
Antenna current, Ia is used for Ia indication and monitoring the matching condition.

Table 5.8.2 Matching Condition

Frequency	Tune OK		Tune NG	
3.36 MHz or less	VSWR<3.0	Matching data is memorized.	VSWR>3.0	Matching circuit short circuits.
3.36 MHz or more	VSWR<2.0		VSWR>2.0	

The maximum inductance of the matching circuit is about 50 uH. To tune 2 MHz band signal to about 7m antenna, most coils in the matching circuit are used. C171 and C172 are used when the antenna capacitance is 40 pF or less and when the supplied voltage to the antenna is 6 kV or more.

Matching circuit

Gamma matching

The gamma matching circuit, Fig.5.8.3 is used in MF band.

Fig.5.8.4 shows approximate values of Ct and Lt in the circuit for typical bands.

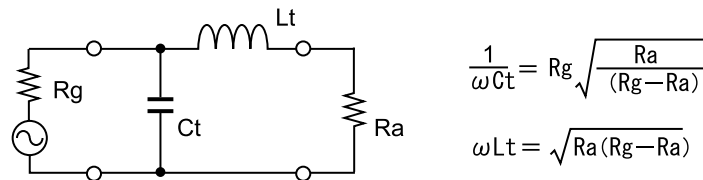

Fig.5.8.3 Gamma matching circuit

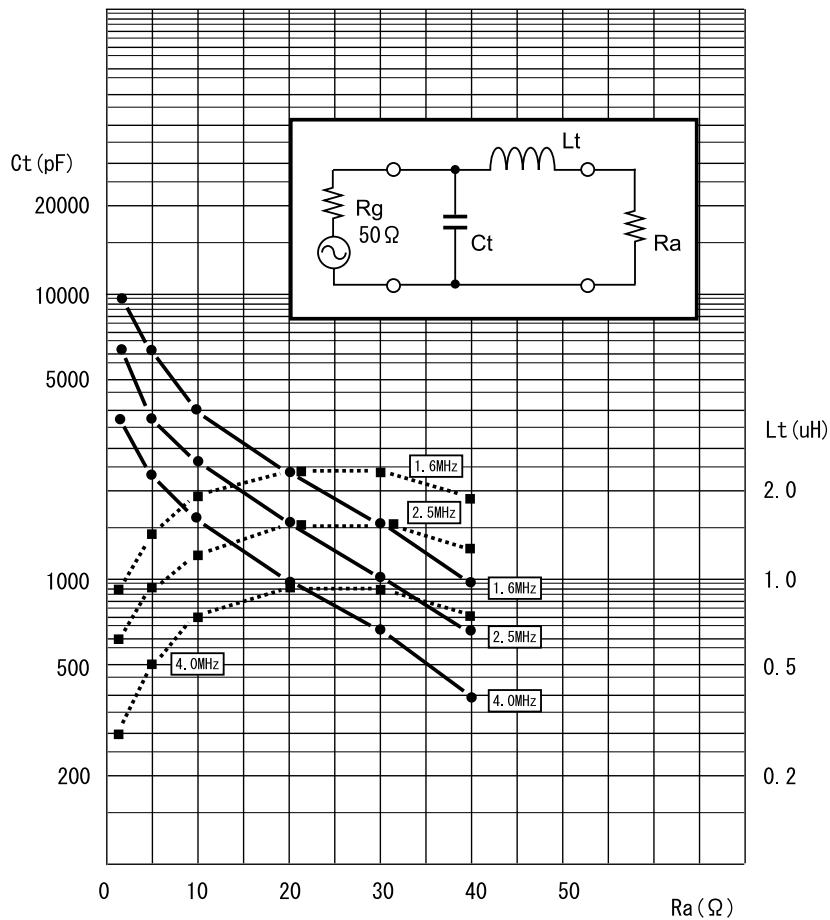

Fig.5.8.4 Ct and Lt in Gamma matching circuit

The antenna includes resistance, R_a and reactance components. As the wavelength of MF band is longer than the antenna length, the antenna becomes capacitive. The matching circuit needs to cancel the capacitance by adjusting the coil inductance. The coil is called the loading coil. The inductance in the matching circuit is the sum of the matching inductance and inductivity of the reactance coil.

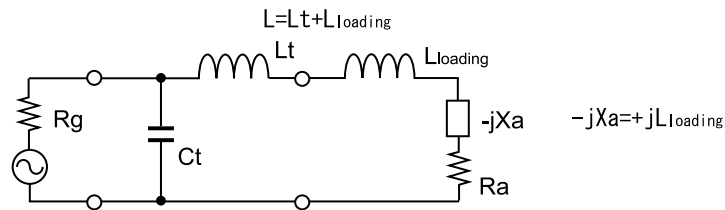

Fig.5.8.5 Antenna equivalent circuit

Fig.5.8.6 shows inductances necessary in the matching circuit to cancel the antenna capacitance.

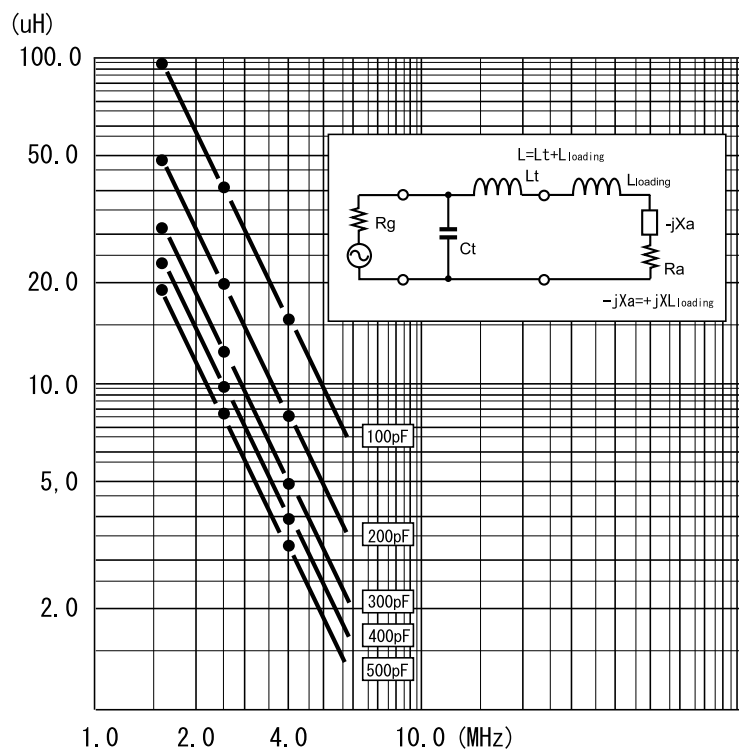

Fig.5.8.6

Pi matching

Pi matching circuit is used in the HF band. Fig.5.8.7 shows pi matching and the equivalent circuits.

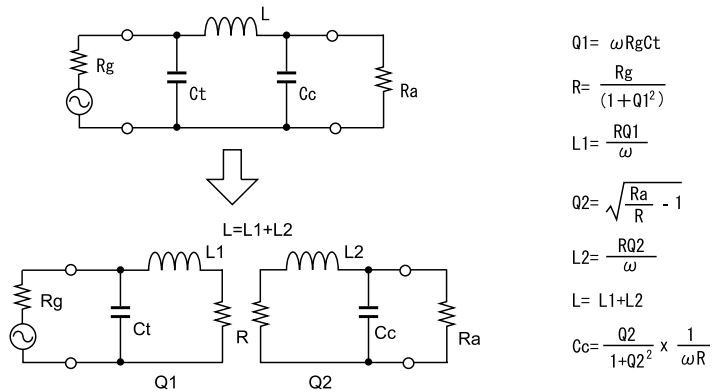

Fig.5.8.7 Pi matching circuit

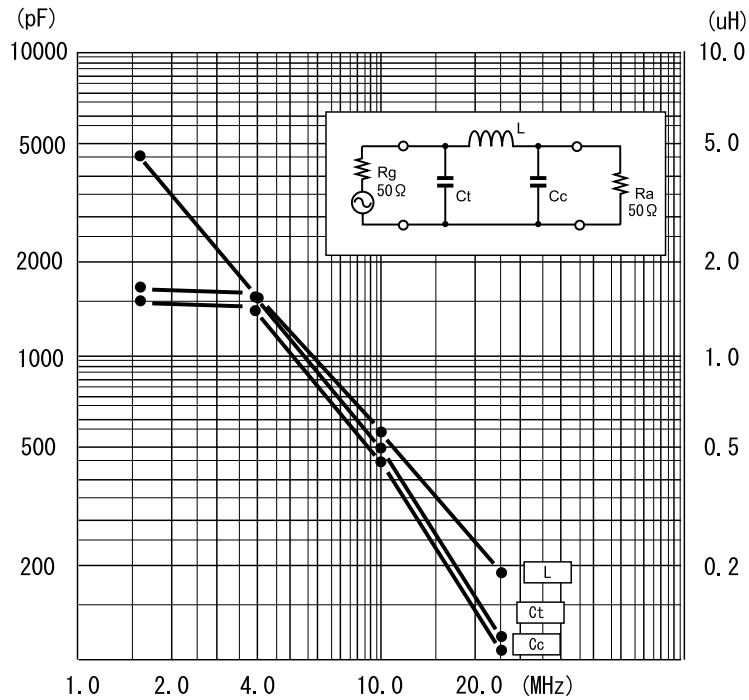
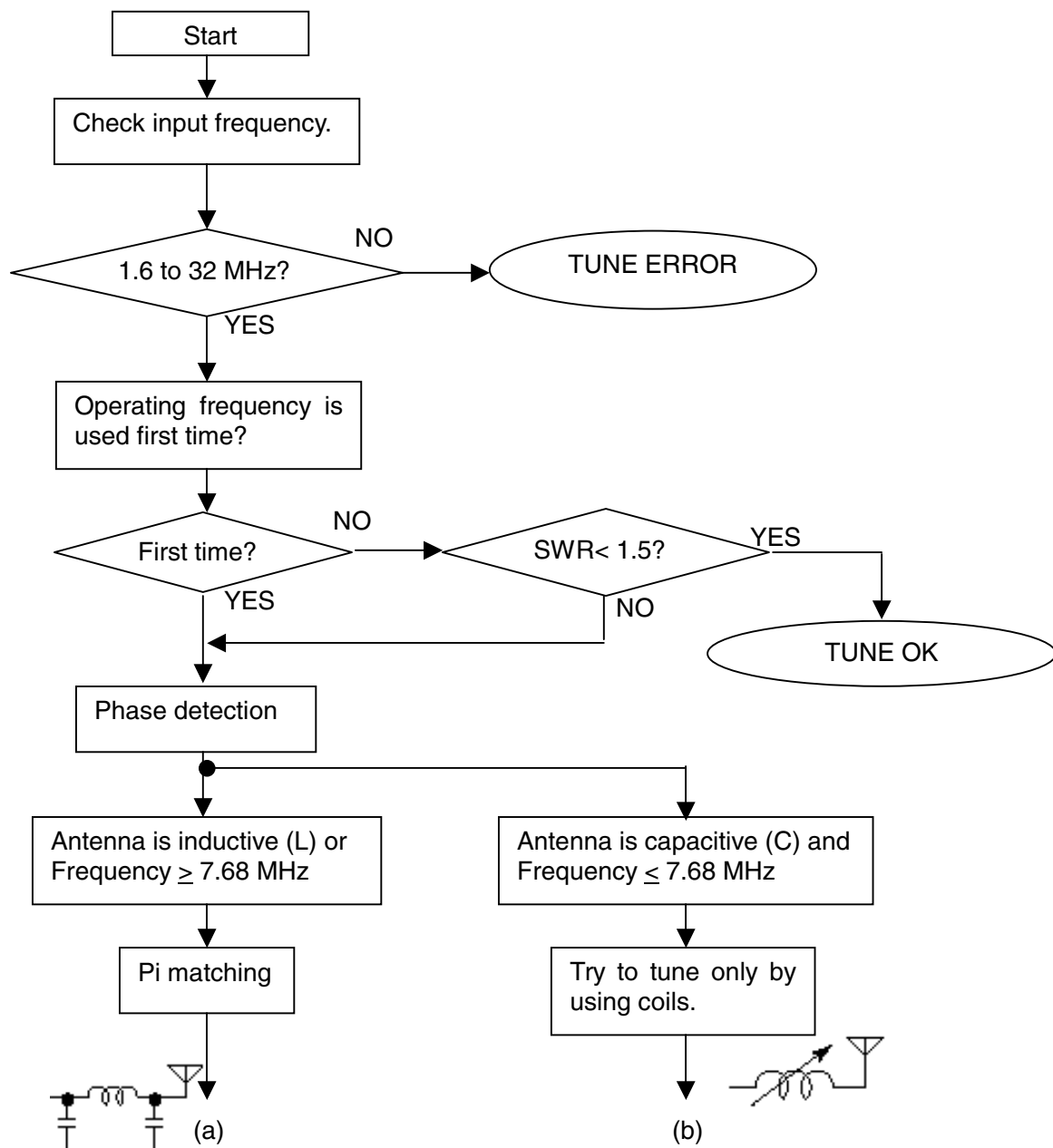

Fig.5.8.8 C and L in Pi matching circuit for 50-ohm load

5.8.1 Antenna tuning



TUNE OK: “TUNE OK” signal is sent to the transceiver unit and relay on/off condition is memorized onto EEPROM.

TUNE ERROR: “TUNE ERROR” signal is sent to the transceiver unit while the matching circuit is bypassed.

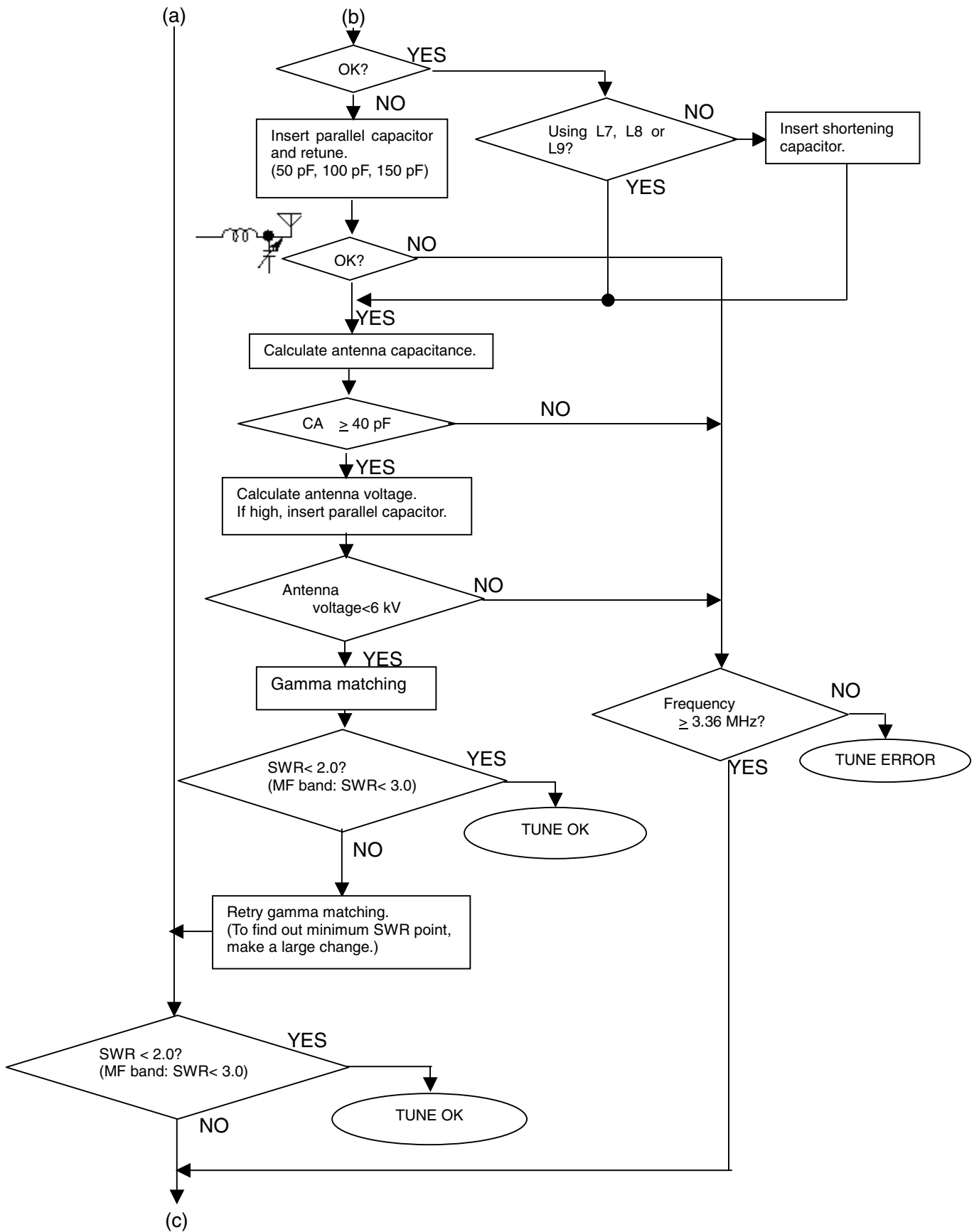

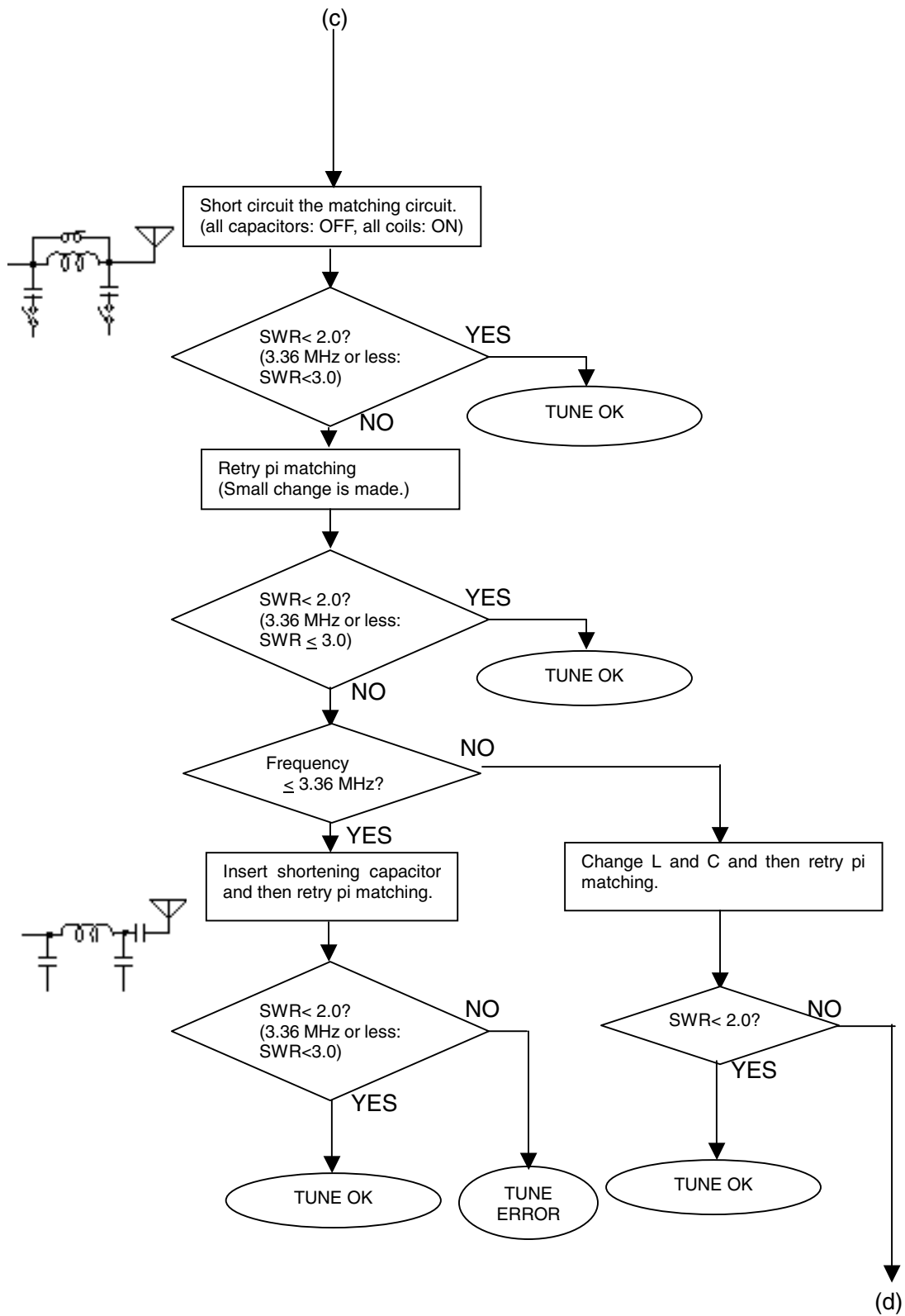

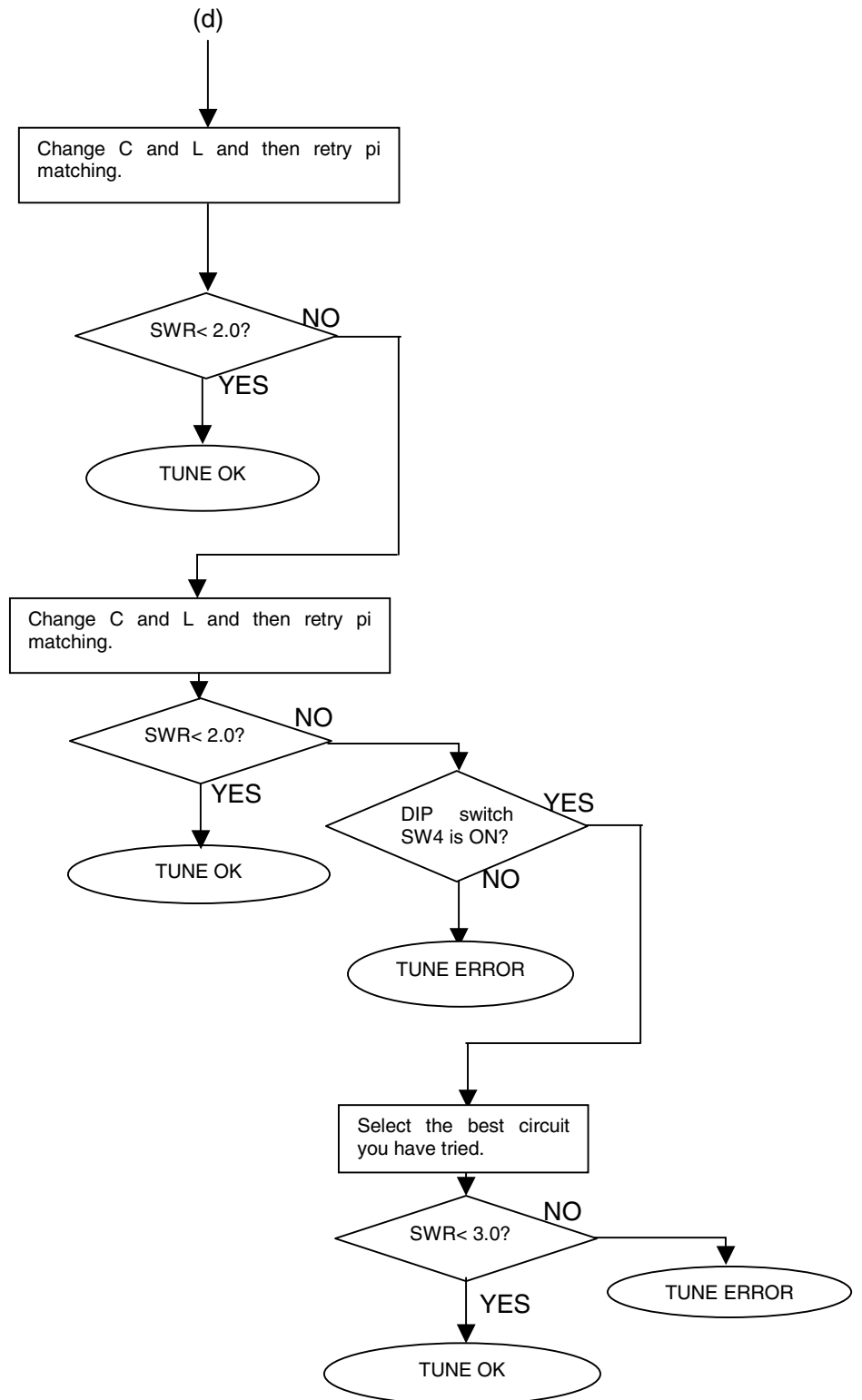

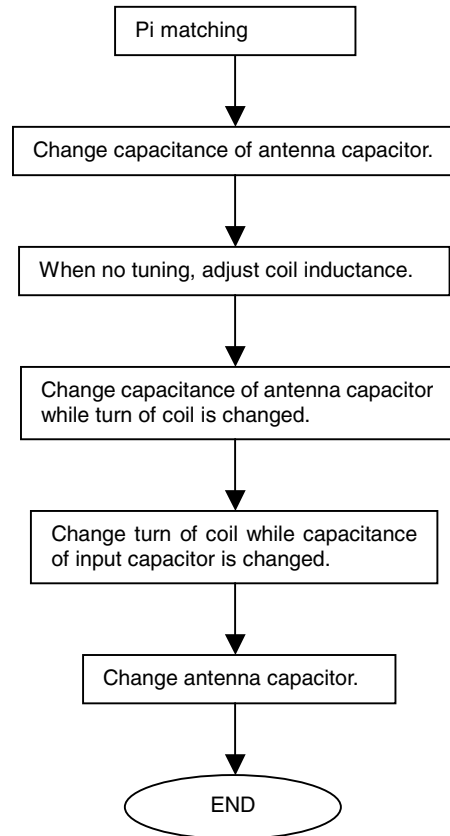
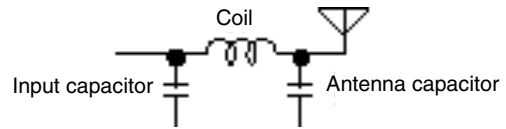
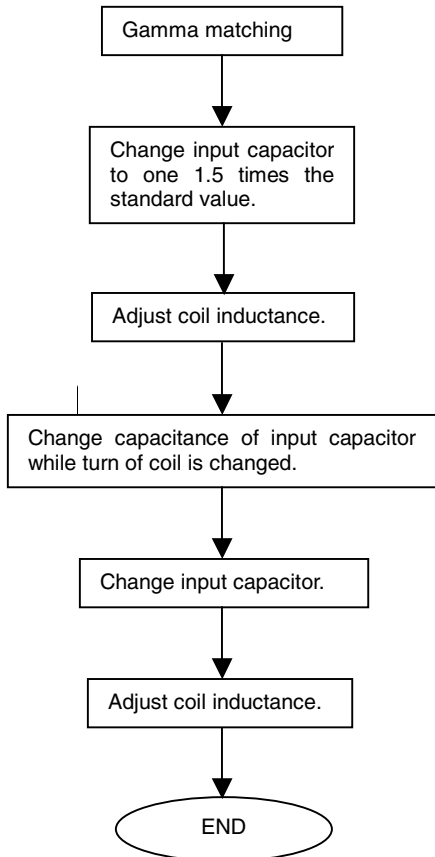
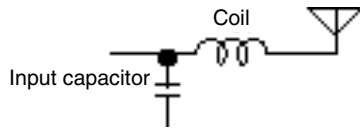

5.9 IB-583

IB-583 is a NBDP terminal newly developed for FS-1560/FS-2570.

Both TERM CPU board (16P0209A) and POW board (16P0211A) are not compatible with those used in the FELCOM 15 terminal unit because some parts are not mounted.

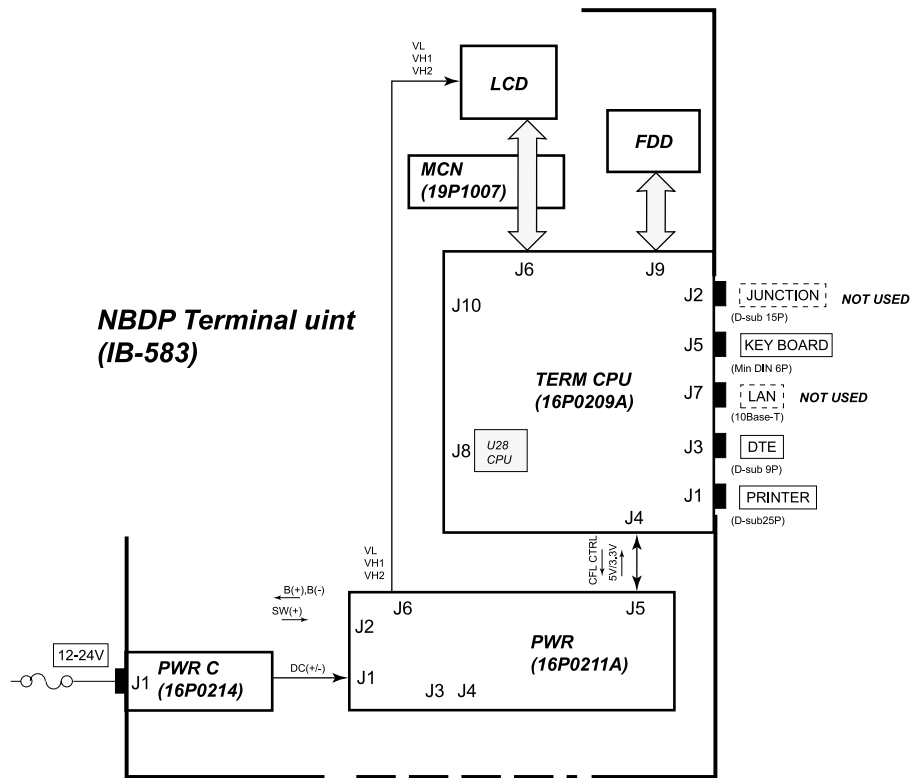

Fig.5.9.1 Block diagram of IB-583

Major function

- 1) Communication with RF CON/CPU board (RS-232C, asynchronous, No command)
 - Baud rate: 9600
 - Data length: 8 bit
 - Stop bit: 1 bit
 - Parity: No parity
 - Flow control: None
 - Communication control: None (Only TX/RX data)
- 2) LCD display (U12) control
- 3) Backup by lithium battery
- 4) Key board connection (U7)
- 5) FDD (U7): 2HD

The IB-583 does not support MIF communication.

5.9.1 TERM CPU board (16P0209A)

Fig.5.9.2 shows the block diagram of TERM CPU board.

Memory

Table 5.9.1 lists the memory contents.

Table 5.9.1 Memory contents

U3 and 4 (S-RAM backedup)	U14 (Flash ROM)
<ul style="list-style-type: none"> • AAB/ID • USER CH • Station List • Scan Group • Timer OP • System data 	Program (Including ITU-CH table)

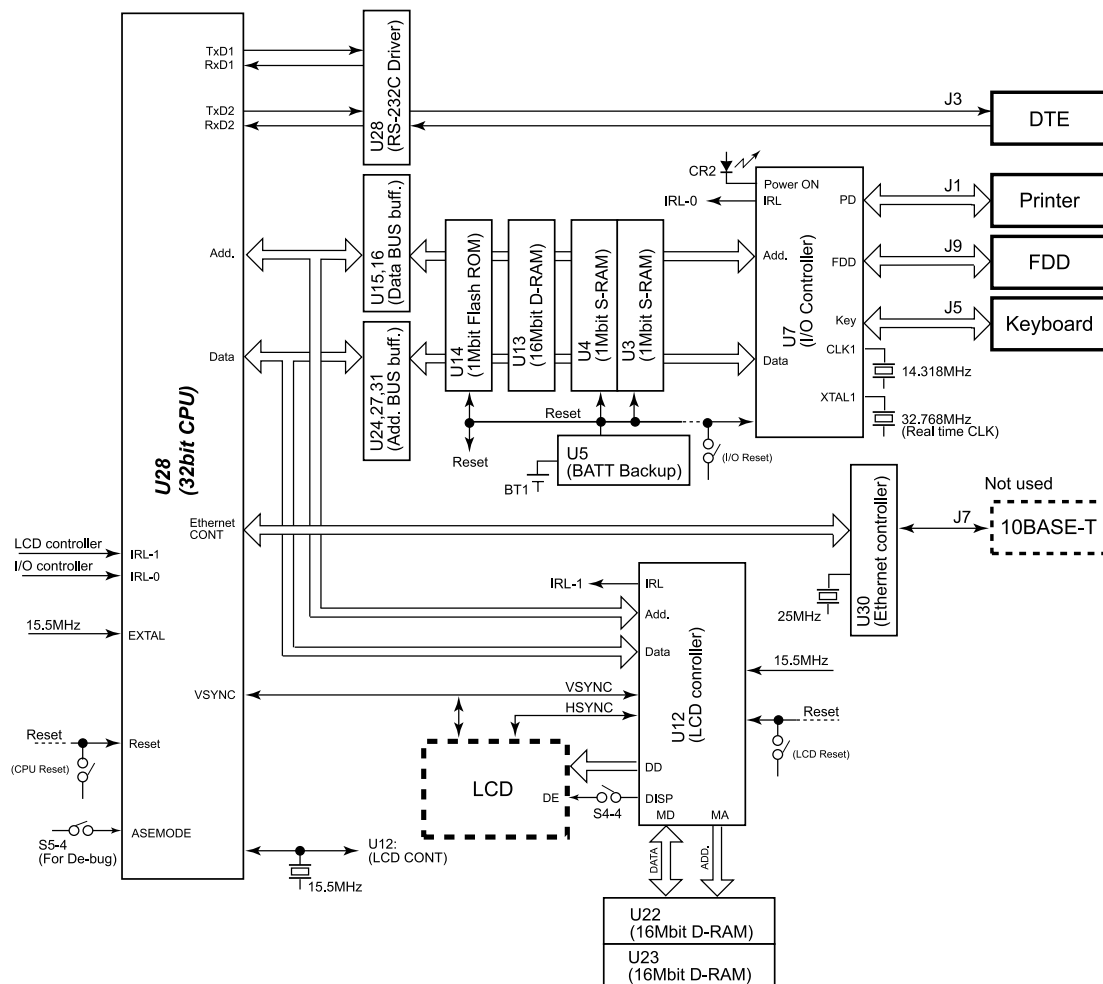

Fig.5.9.2 Block diagram of TERM CPU Board

5.9.2 PWR Board (16P0211A)

The switching regulator on PWR board operates from 10.8 to 31.2 V power supply.

Output voltage

- +6.5 V, +3.3 V and +5.0 V
- VH1 and VH2 used as LCD power supply

Protection circuit

- Power reverse connection protector (Diode provided, In-line fuse on the power cable blows out.)
- Input overvoltage protector (32 to 37 V)
- Input lowvoltage protector (7.5 to 8.5 V)
- Over current protector

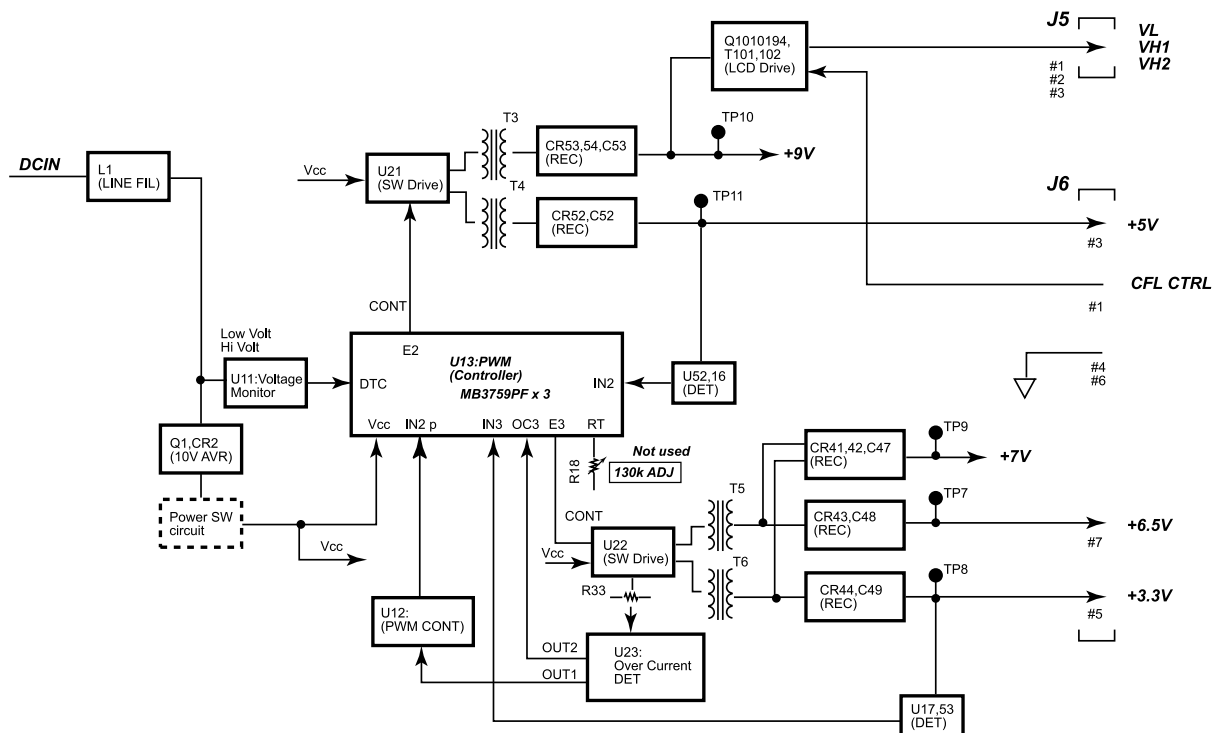

Fig.5.9.3 Block diagram of PWR Board

Chapter 6. Maintenance

6.1 Self-test

Following describes DSC and RT test.

6.1.1 DSC test

To check DSC circuit;

1. Press [6/SCAN] to show the DSC display.
2. Press [3/TEST]. "Daily test" menu is displayed and the test is started automatically. The test item depends on system configuration.
 - PANEL2: Displayed when No.2 FS-2570C is installed. (PANEL 2; No.1 FS-2570C)
 - NBDP MODEM: Displayed when NBDP DSP board is installed.
 - RCVR2: Displayed when W/R2 board (optional) is installed. (RCVR 1; W/R 1)

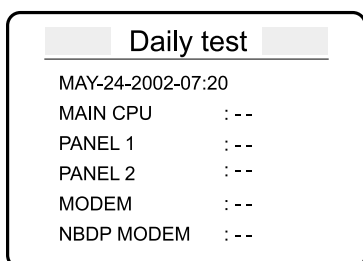

3. After about one minute the result appears. At the end of the test, aural and visual alarm circuits are tested. If normal, a beep sounds and LEDs light.

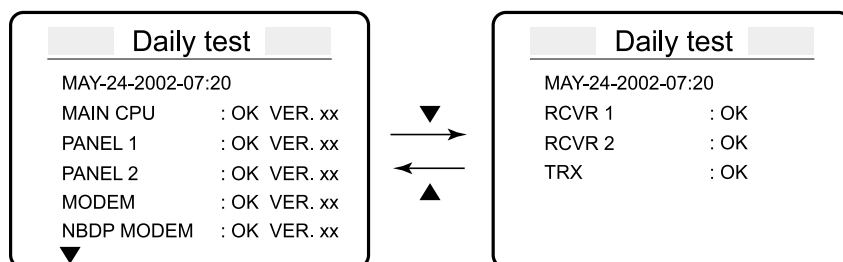

4. Press [CANCEL] to return to DSC menu.

Checking detail program number

With Daily test result display, press [1/RT] five times while holding [FILE] to check detail program number.

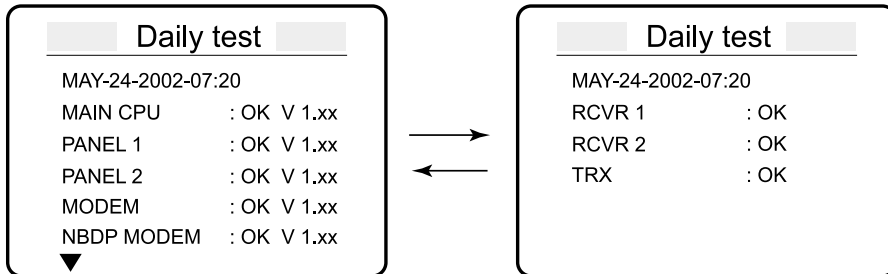
Printing out test result

Press [8/PRINT] to print out the test result. Automatic printing out of the DSC test result is selected in "PRINT OUT" setting in DSC SETUP menu. Set DIALY TEST to ON.

Example

```

* FS-xxxx DAILY TEST *
MAY-24-2002-07:20
MMSI          :431456789
MAIN CPU      :OK VER. xx
PANEL 1 CPU   :OK VER. xx
PANEL 2 CPU   :OK VER. xx
MODEM         :OK VER. xx
NBDP MODEM    :OK VER. xx
RCVR 1        :OK
RCVR 2        :OK
TRX           :OK
  
```

Table 6.1.1 lists the boards to be tested.

Table 6.1.1 Tested board by DSC test

Test Item	Boards NG appear
MAIN CPU	T-CPU
PANEL 1 CPU	T-CPU or C-CPU in No.1 FS-2570C
PANEL 2 CPU	T-CPU or C-CPU in No.2 FS-2570C
MODEM	DSC DSP
NBDP MODEM	NBDP DSP
RCVR 1	W/R1
RCVR 2	W/R2
TRX	TX/RX

DSC test items**MAIN CPU**

Displays T-CPU program version.

PANEL 1

Displays C-CPU program version of FS-2570C connected to [CONTROLLER-1]. T-CPU communicates with C-CPU.

PANEL 2

Displays C-CPU program version of FS-2570C connected to [CONTROLLER-2]. T-CPU communicates with C-CPU.

When No.2 FS-2570C is not connected, PANEL 2 line is blank.

MODEM

Displays the program version of DSC DSP board (05P0751). T-CPU communicates with DSC DSP.

NBDP MODEM

Displays the program version of NBDP DSP board (05P0751). T-CPU communicates with NBDP DSP. When NBDP DSP board is not installed, NBDP MODEM line is blank.

RCVR 1

DSC watch receiver (W/R1 board, 05P0734) is tested. J2B, 18 MHz signal, modulated by mark and space tones, is applied to antenna input line, using a stray capacitor; Cs. The signal level is about 70 to 80 dB. DSP board (Modem) detects the tone signal when W/R board is normal.

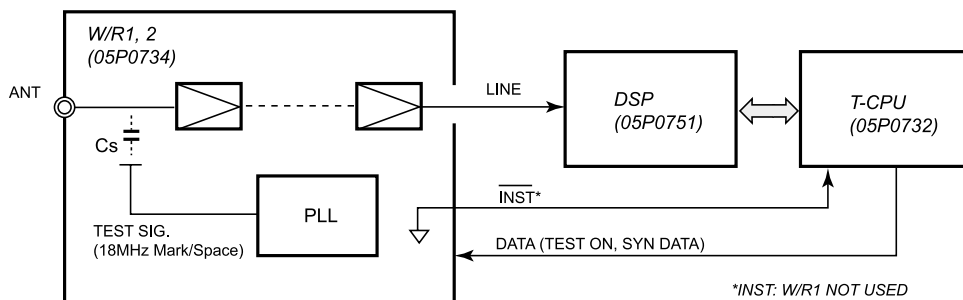

Fig.6.1.1 RCVR test signal flow

RCVR 2

The test flow is the same as that of “RCVR 1” check.

DSC general frequencies watch receiver (W/R2 board, 05P0734) is tested. When W/R2 board is not installed, RCVR2 line is blank.

The J2B signal, modulated by mark and space tones, is connected to the antenna input using a stray capacitor. The level is about 70 to 80 dB. DSP board (Modem) detects the tone signal when W/R2 board is normal. When W/R2 is installed, INST signal of “L” level is sent to T-CPU from J2-#12 on W/R2. Thus, T-CPU knows the presence of W/R2. See Fig.6.1.1 for test signal flow.

TRX

TX/RX board is tested. The J2B, 18 MHz signal, modulated by mark and space tones, is coupled to the antenna input line by a capacitor, C201. The level is about 20 to 30 dB. DSP board detects the tone signal when TX/RX board is normal.

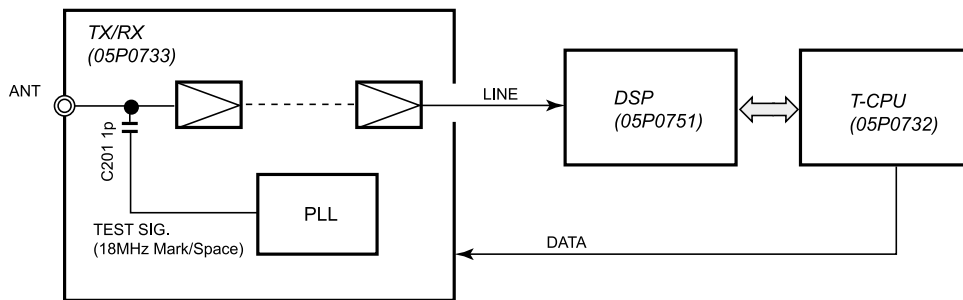

Fig.6.1.2 TRX test signal flow

6.1.2 RT test

To check RT circuit;

1. Press [1/RT] to show RT menu.
2. Press [3/TEST]. "Tx self test" menu appears and the test is automatically started. The dummy in the antenna coupler is used during the test.

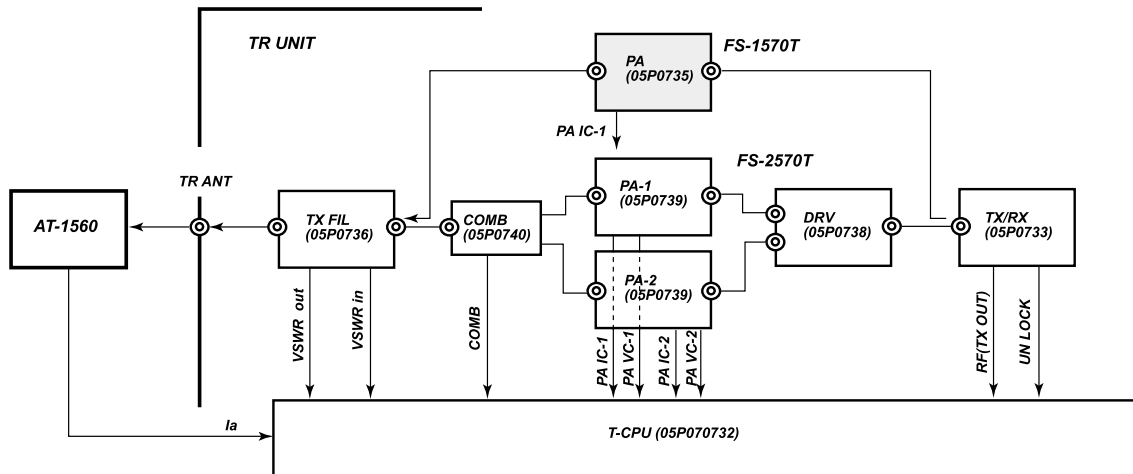

Fig.6.1.3 RT test signal flow

3. The test result looks like the follows. RT test result cannot be printed out.

Tx selftest	
PLL : OK	
RF : OK	TXFIL : OK
PA 1 : OK	COUPL : OK

FS-1570 test result

Tx selftest	
PLL : OK	PA 2 : OK
RF : OK	COMB : OK
PA 1 : OK	TXFIL : OK
	COUPL : OK

FS-2570 test result

4. Press [CANCEL] to return to RT menu.

RT test items**PLL**

The PLL circuit on TX/RX board (05P0733) is tested. By changing the frequency, PLL UN-LOCK-1 signal is monitored.

The test frequency includes 2300 kHz, 4500 kHz, 7700 kHz, 11500 kHz, 15500 kHz, 19000 kHz, 23500 kHz, and 27500 kHz. When the test detects an error, NG appears.

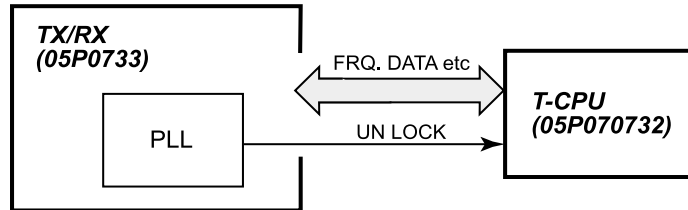

Fig.6.1.4 PLL test signal flow

RF

The output power from TX/RX board (05P0733) is measured. If it is normal, "OK" appears. 2190 kHz (J2B) mark tone signal and the power data of 110 for FS-1570 and FS-2570 are used.

If "NG", TX/RX board is defective.

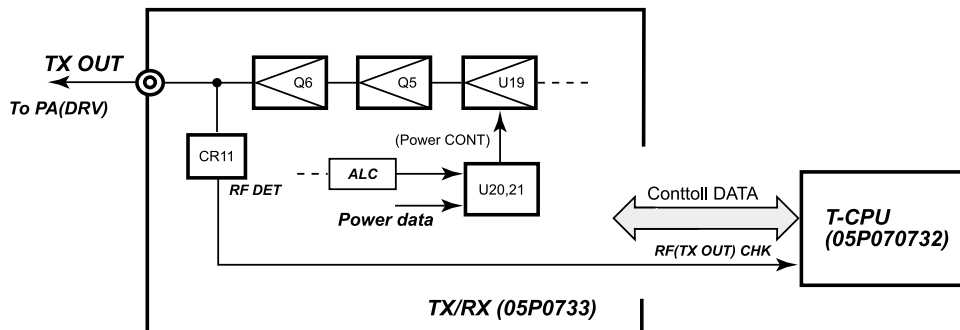

Fig.6.1.5 RF test signal flow

PA 1

Ic and Vc of power amplifier on PA board (FS-1570T: 05P0735; FS-2570T: 05P0739) are measured. If the value is within the rating, "OK" appears. The test signal is the same as that of RF check.

PA 2

PA2 line is blank when FS-1570T is connected.

Ic and Vc of power amplifier on PA-2 board (05P0739) in FS-2570T are measured. If the value is within the rating, "OK" appears.

The test signal is the same as that of RF check.

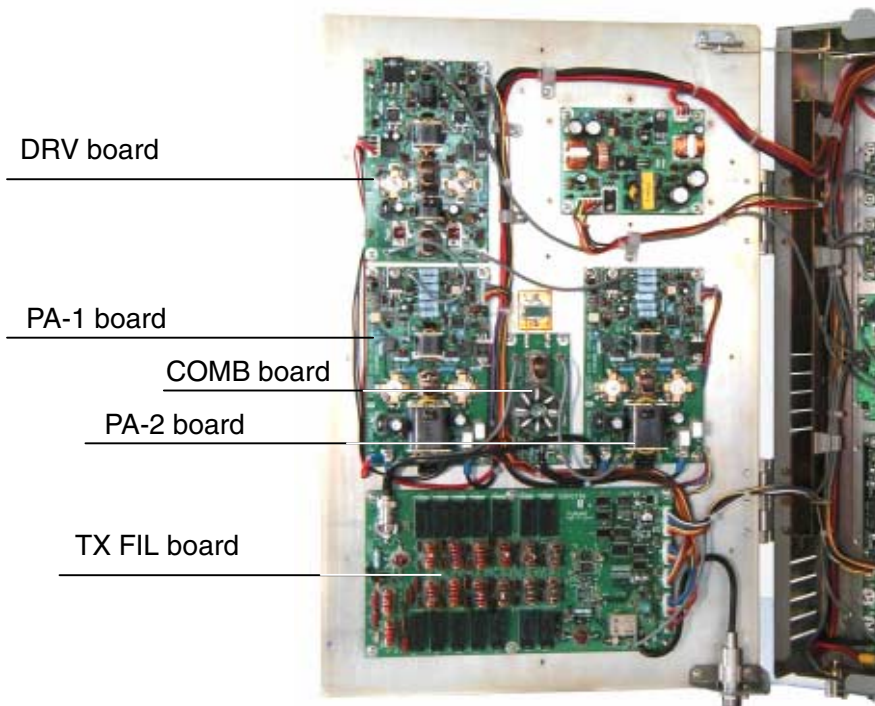
FS-2570 check meter

Vc: indicates Vc on PA-1 board

Ic: indicates the sum of PA-1 Ic and PA-2 Ic.

Fig.6.1.6 Location of power amplifier

COMB

The output from COMB board (05P0740) is measured. If normal, "OK" appears. The test signal is the same as that of RF check.

TXFIL

Forward voltage, V_f is measured by a VSWR detector in input and output circuits on TX FIL board (05P0736). If V_f is within ratings, "OK" appears.

The test signal includes 2190 kHz, 3000 kHz, 4200 kHz, 6200 kHz, 8200 kHz, 12400 kHz and 22000 kHz to check all low pass filters. The power data of 90 is used on FS-1570 and FS-2570.

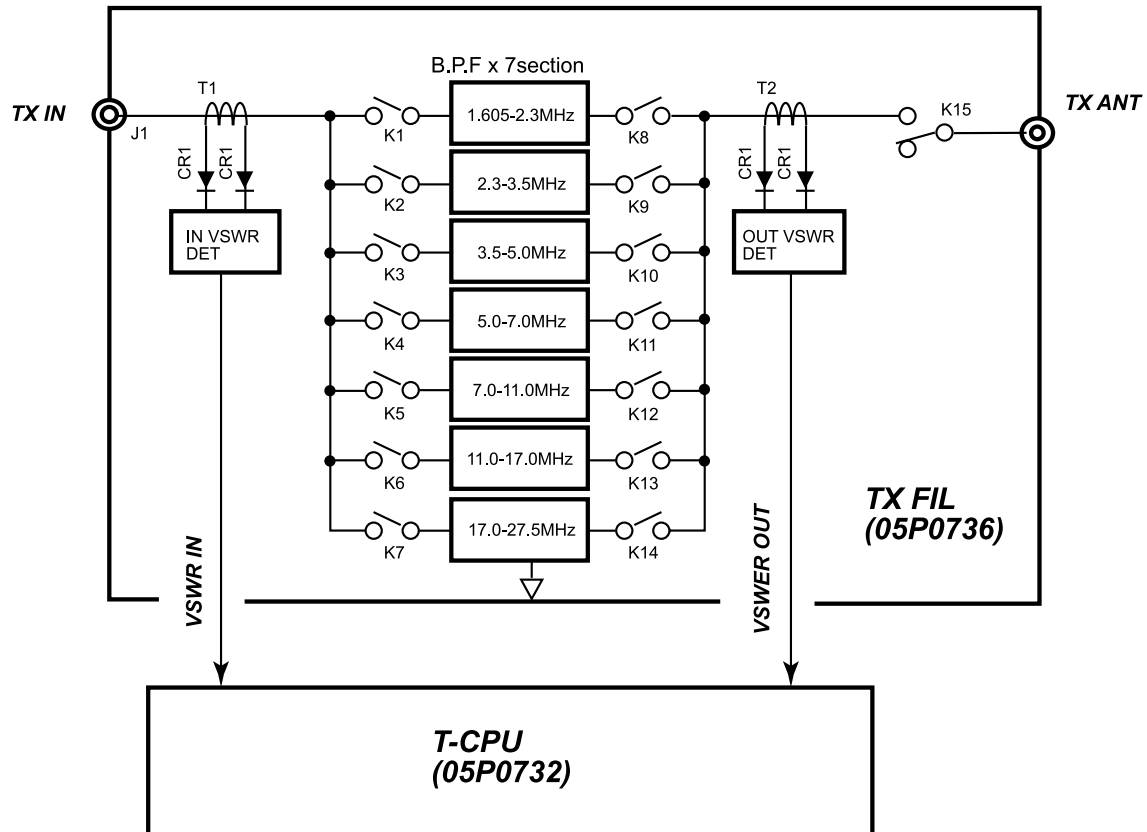

Fig.6.1.7 TX FIL VSWR detector

COUPL

Antenna coupler, AT-1560 is tested. Connecting dummy (10 ohm+250 pF), 2190 kHz test signal is sent to the coupler. If TUNE OK signal is detected and the antenna current, IA is more than the rated value, "OK" appears. TUNE circuit is tested with power data of 90 (TUNE POWER) and IA is measured with 110 on FS-1570 and FS-2570.

RT Test flow

Fig.6.1.8 shows the RT test flow.

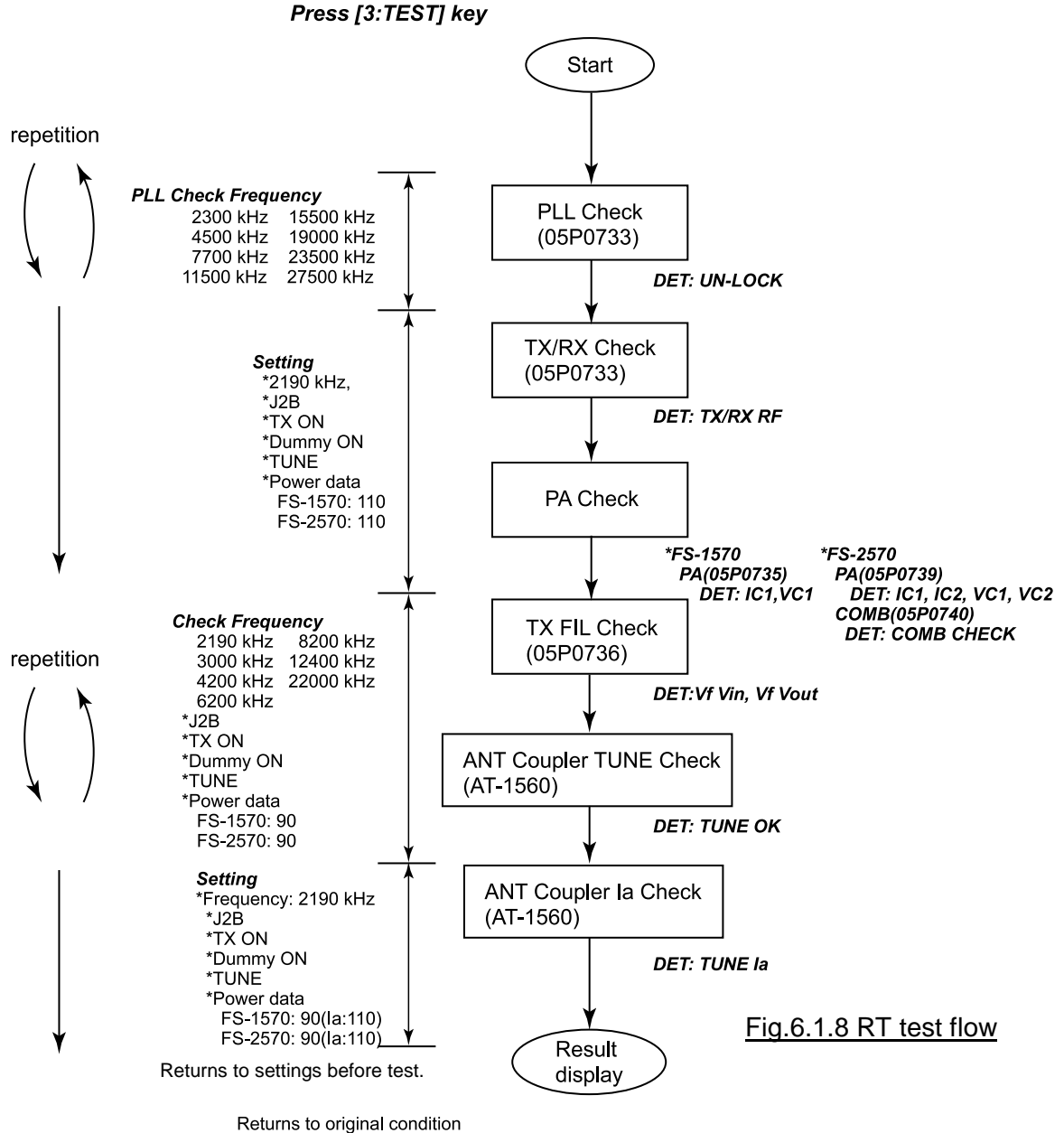

Fig.6.1.8 RT test flow

Table 6.1.2 RT test results

	FS-1570	FS-2570
PLL Check	UN-LOCK or LOCK	UN-LOCK or LOCK
TX/RX Check	TR output about 10 W	TR output about 10 W
PA Check	IC1: about 3 A	IC1: about 3 A IC2: about 3 A
	VC1: about 20 V	VC1: 20 V
		COMB: TR output about 10 W
TX FIL Check	Vf in: about 10 W Vfout: about 10 W	Vf in: about 10 W Vfout: about 10 W
ANT Coupler	TUNE OK or NG IA: about 0.8 A	TUNE OK or NG IA: about 0.8 A

6.2 Self test of Antenna coupler

The antenna coupler provides self-test function as below.

To test the antenna coupler, AT-1560;

1. Remove the dummy board.
2. Set the DIP switch, S2-#2 to ON.

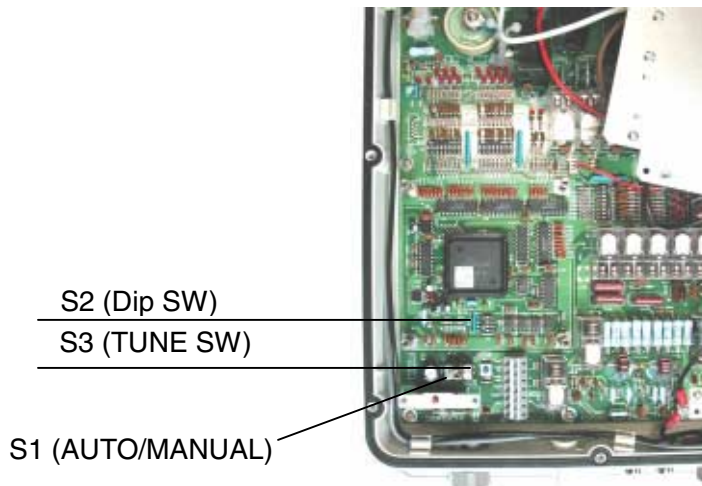

Fig.6.2.1 COUP board with Dummy board removed

3. Set AUTO/MANUAL switch (S1) to “AUTO”. In “MANUAL” position, the self test is not executed.
4. Set TUNE SW (S3) to ON.
5. Relays are switched on/off in order as shown by the arrow in Fig.6.2.2. The test result is displayed by LEDs.



Fig.6.2.2 Order of relay test

- 1) When CR1 is on, built-in ROM of U1 is detective.
- 2) When CR2 is on, built-in RAM of U1 is detective.
- 3) When CR3 is on, built-in A/D converter of U1 is detective. The matching circuit before the test is selected when the test is complete.

6. Set the DIP switch, S2-#2 to OFF.

6.3 Self-test of Terminal Unit

The self-test procedure for IB-581 and IB-583 is the same.

To carry out the self-test on the terminal unit;

1. Press [F6].
2. Move the cursor to "Change" and then to "Self Test".
3. Press [Enter].
4. The self-test starts automatically. The self-test result display looks like below.

Self test		
Terminal Unit Test	: Ver 1.22	OK
Main Unit Test	: Ver .01	OK
Modem Unit Test	: Ver .01	OK
Radio Unit Test	: ID FS1570	OK
DSC Unit Test	: ID FS1570	OK
Print Unit Test	: Print All Character	OK

Fig.6.3.1 Self test result display

To show detail program version;

Press [F1] while holding [Alt] and [Fn] with the self-test result on the screen.

Self-test items

Terminal Unit Test

Shows the terminal (IB-581/IB-583) program version.

Main Unit Test

Shows the program version for T-CPU in the transceiver unit.

Modem Unit Test

Shows the program version of NBDP DSP board.

Radio Unit Test

Shows the model of the transceiver unit. When the model is FS-2570, "ID FS2570" appears on this line.

DSC Unit Test

Shows the model of the transceiver unit. When the model is FS-2570, "ID FS2570" appears on this line.

Print Unit test

Prints out the following characters automatically.

```
-----<Printer test>-----  
0123456789 ABCDEFGHIJKLMNOPQRSTUVWXYZ +=?[].,=/@%z  
-----<Printer OK>-----
```

6.4 Tone test

Tone test signal is generated through “Tone test” menu. To show the “Tone test” menu, press [F6], move the cursor to “Self test”, and then press [↓] while holding [Sift].

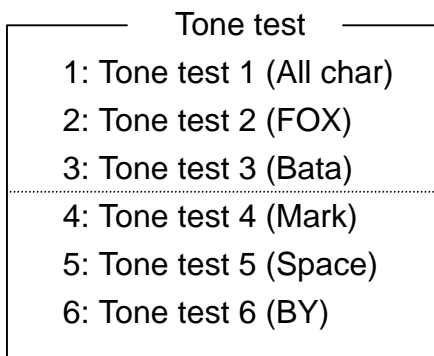

Fig.6.4.1 Tone test display

(1) 1 to 3 Tone test

These tests are performed with the line connected. When the called station receives characters normally, the test is successful.

To send characters;

1. Connect the line and set the system to ISS (Information sending station).
2. Select test 1 or 2 from “Tone test” menu and then press [Enter]. “All” or “FOX” character is transmitted.

- 1) Tone test 1 (All char) transmits the following character

“ABCDEFGHIJKLMNOPQRSTUVWXYZ1234567890-?()., ’=/+ABCDEFGHI
JKLMNOPQRSTUVWXYZ”

- 2) Tone test 1 (FOX) transmits the following character

“THE QUICK BROWN FOX JUMPS OVER THE LAZY DOG 0123456789”

- 3) Tone test 1 (Bata)

The idling signal or β signal is transmitted. No character appears on the display.
This line is used at type approval test.

(2) 4 to 6 Tone test

These tests are used to generate mark and space tones. The generated tone is observed at TP4 on NBDP DSP board.

1) Tone test 1 (Mark)

Mark tone (1700 Hz-85 Hz) is generated.

2) Tone test 1 (Space)

Space tone (1700 Hz+85 Hz) is generated.

3) Tone test 1 (BY)

Mark and space tones (1700 Hz \pm 85 Hz), 100 bps are generated.

The same tone is also generated through the system setting menu. See page 7-10.



Fig.6.4.2 DSP Board

6.5 TEST function in DSC SETUP menu

The following describes the factory-test. To unlock the test menu, a password is required.

6.5.1 Unlocking TEST menu

To unlock the TEST menu;

1. Press [6/SCAN] to show the DSC display.
2. Press [SETUP] to show the DSC setup menu.
3. Move the cursor over [3/TEST] and then press [ENT]. The “Test function” menu appears with “PROTECTION ON” message.

Test function	
TONE TX	T-CPU PCB
REMOTE	C-CPU PCB
EXT ALARM	TX/RX PCB
EXT ALERT	W/R PCB
PANEL PCB	TA TEST
PROTECTION ON	

4. Enter the password ([x][x][x][x][x][x]) to unlock the menu. Table below summarizes test items.

Table 6.5.1 TEST items in Test function

Test function	Description
TONE TX	Outputs TONE to check the modulator output in the transmitter.
REMOTE	Loop-back test for REMOTE ports
EXT ALARM	Checks IC-303-DSC control signal
EXT ALERT	Checks IC-302-DSC control signal
PANEL PCB	Checks FS-2570C panel control signal
T-CPU PCB	Checks T-CPU board control signal
C-CPU PCB	Checks C-CPU board control signal
TX/RX PCB	Presets frequency for PLL and receiver adjustment
W/R PCB	Presets frequency for PLL and receiver adjustment
TA TEST	Used at type approval

TONE TX

The same menu as that in RT System Setup menu. See page 7-10.

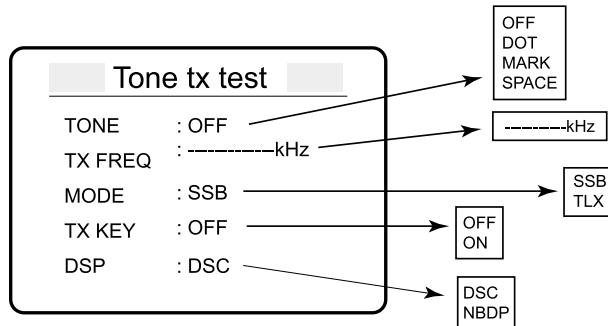

REMOTE

Remote ports are tested by jumpering. Loop back test jumper is shown in Table 6.5.2 to make a loopback circuit. Before test, DIP switch on T-CPU board is also changed as below.

Table 6.5.2 Loop Back Test jumper

Test item	Port	Jumpers	DIP switch setting on T-CPU board	Remarks
NBDP	[NBDP] port on FS-2570C	#2 (SD)-#3 (RD)	—	RS-232C
NMEA	TB6	#22 (TD3A)-#24 (RD3A) #23 (TD3B)-#25 (RD3B)	—	RS-422
DMC	TB6	#27 (TD4A)-#29 (RD4A) #28 (TD4B)-#30 (RD4B)	S6-#1 to #4: ON S7-#1 to #4: OFF	RS-422
MIF	REMOTE port	#2 (SD)-#3 (RD)	S3-#1 and #2: OFF S3-#3 and #4: ON	RS-232C
		#21 (TD5A)-#23 (RD5A)	S3-#1 and #2: ON	RS-422
		#22 (TD5B)-#24 (RD5B)	S3-#3 and #4: OFF	

Note)

- When NBDP terminal is connected to the NBDP port, the model is displayed, instead of OK on NBDP lines.
- When DMC is connected to the DMC port, the model is displayed, instead of OK on DMC lines.

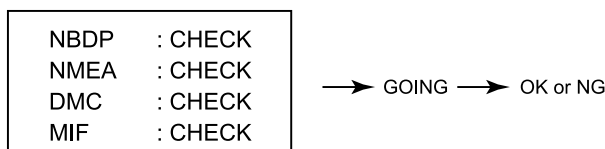

EXT ALARM

IC-303-DSC is tested. When [ENT] is pressed, the beep is released and the LED blinks on IC-303-DSC. The same is done on FS-2570C.

To finish the test, press [CANCEL].

External alarm
test in progress.

EXT ALERT

The distress alert transmitter is tested without actual transmission.

Select EXT ALERT and then press [ENT]. “Waiting for external alert sw.” appears.

Press the distress alert button on IC-302-DSC, and the alarm is released and the LED blinks on IC-302-DSC. After three seconds, the LED changed to on. The same is done on FS-2570C.

To finish the test, press [CANCEL].

External alert
test in progress.

PANEL PCB test

The “LCD”, alarm LEDs, keys and the knob are tested.

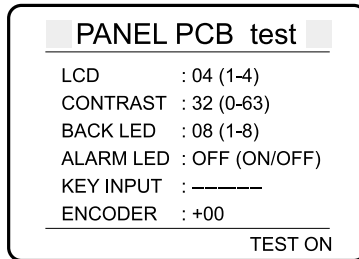

- LCD: LCD is tested by four patterns.
- CONTRAST: LCD contrast is tested. The larger the number, the higher the brightness.
- BACK LED: Backlight LEDs for keyswitches are tested.
- ALARM LED: ALARM and DISTRESS LEDs are tested.
- KEY INPUT: Keys except for [CANCEL] and [POWER]SW are tested. Acronym on the key top appears when the key is pressed.
- ENCODER: Rotating the knob from fully ccw to fully cw changes the indication from -99 to +99.

T-CPU PCB test

The T-CPU PCB test is made on two pages. The result is showed by OK or NG.

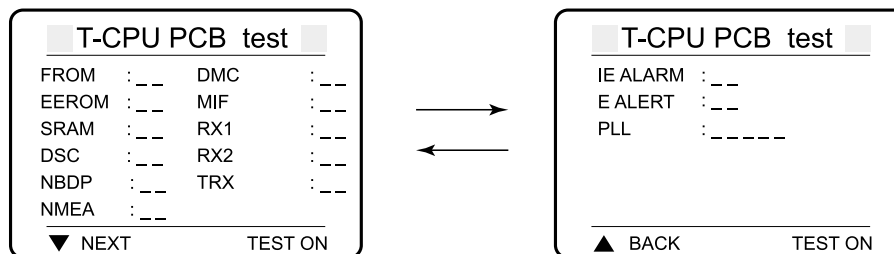

- FROM: Shows T-CPU program version. The program is installed on Flash ROM (U4).
- EEROM: Shows the read/write test result of EEPOM (U5).
- SRAM: Shows the read/write test result of SRAM (U6 and U7).
- DSC: Shows the DSC program version.
- NBDP: Shows the NBDP program version.
- NMEA: Loopback test of the NMEA data line. The same as REMOTE test on page 6-16. The test jumper is required.
- DMC: Loopback test of DMC data line. The same as REMOTE test on page 6-16.
- MIF: Loopback test of MIF data line. The same as REMOTE test on page 6-16.
- RX1: W/R1 board is tested. The same as RCVR-1 in DSC self test. See page 6-1.
- RX2: W/R2 board is tested. The same as RCVR-2 in DSC self test. See page 6-1.
- TRX: TX/RX circuit is tested. The same as TRX in DSC self-test. See page 6-1.

- E ALARM: External incoming indicator (IC-303-DSC) test. Press the button after pressing [ENT]. The alarm is released and LED lights on IC-303-DSC. The alarm is also released from FS-2570C.
- E ALERT: External distress alert button (IC-302-DSC) test. Press the button after pressing [ENT].
- PLL: If it is normal, “-----” appears. When an error is detected, the error name is displayed.

C-CPU PCB test

Figure below shows C-CPU PCB test menu. The test result is showed by OK or NG.

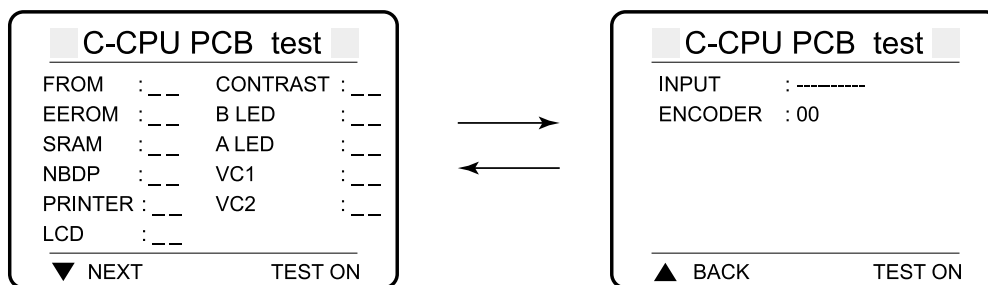

- PROM: Shows the program version of C-CPU. The program is installed on Flash ROM (U4).
- EEROM: Read and write test of EEPOM (U5).
- SRAM: Read and write test of SRAM (U6 and U7).
- NBDP: NBDP port is tested. Connect the terminal or the test jumper. The same as REMOTE test on page 6-16.
- PRINT: Prints out the following characters.
 “0123456789
 ABCDEFGHIJKLMNOPQRSTUVWXYZ
 abcdefghijklmnopqrstuvwxyz”
- LCD: Four patterns are displayed on the LCD.
- CONTRAST: Varies LCD contrast.
- B LED: Brightness of key LED varies.
- A LED: The alarm and the distress button LEDs are switched on/off.
- VC 1: The volume of the external loudspeaker changes.
- VC 2: The volume of the handset speaker changes.
- INPUT: Key function except for [CANCEL] is tested. ON-HOOK and OFF HOOK signals are not detected. The acronym on the key top is displayed.
- ENCODER: The knob is tested. The number changes from -99 (fully ccw) to +99 (fully cw).

TX/RX PCB test

Test mode and the test frequency are set to adjust PLL and to confirm receiver sensitivity. SYS ADJ CH sets the frequency for PLL adjustment and SEN CHK CH for receiver sensitivity check. The channel frequency can be changed. 18MHz receiver test signal is switched on/off by using TEST SIG line.

The frequency on FREQ SWEEP line is set by rotating the knob.

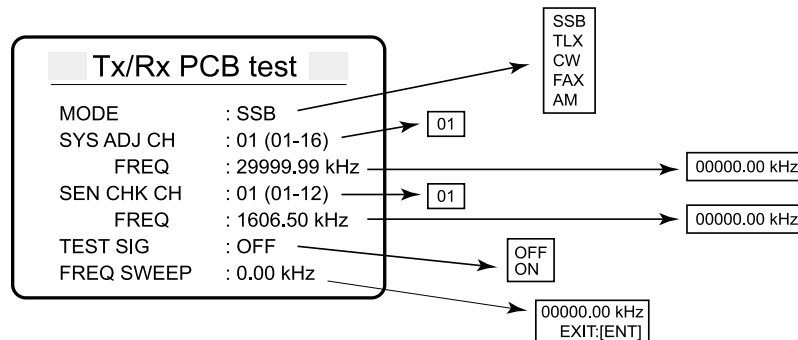

W/R PCB test

This menu is similar to TX/RX PCB test menu. SYN ADJ CH is used to adjust PLL on W/R board and SEN CHK CH to check the receiver sensitivity of W/R board.

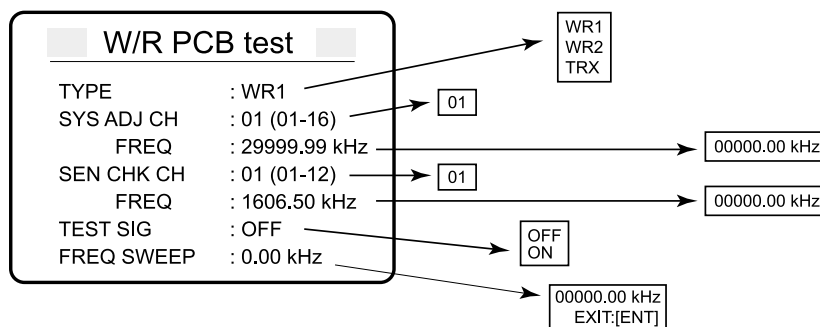

TA TEST

This test is used at type approval.

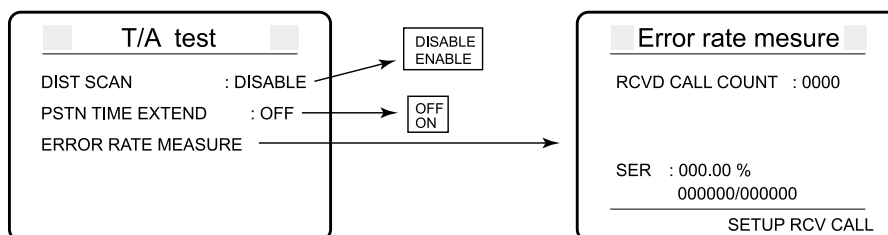

6.6 Messages

Following describes the messages which appear on the control unit and NBDP terminal unit.

6.6.1 Message on control unit

LOAD CONFIG DATA FROM TRX UNIT

The data is loaded from T-CPU to C-CPU at power-on. This is not an error message.

OVEN COLD Tx not ready: WAIT

The oven needs to heat for stabilizing 18 MHz REF oscillator output.

Warning: EPFS error

Position and time data are not received from EPFS (Electronic Position Fixing System) for 60 seconds.

Check EPFS for connection. The receivable NMEA sentences are GGA, RMC, GLL and ZDA. NMEA version is 2.0 or above.

Warning: Update position

Position and time data are not updated for the time set at POSITION OLDER menu. Update the position.

Tx pow reduced Natural tune

The antenna current exceeds 10 A for more than 5 seconds. The output power is automatically reduced with this message.

Change the antenna impedance. Typically, the antenna is changed in length.

TUNE NG

- (1) When TUNE in RT system menu is set to OFF, the antenna coupler does not tune.
- (2) When this message appears just after pressing PTT;
 - Check the connection between the antenna coupler and the transceiver unit.
 - Check MANUAL/AUTO switch (S1) in the antenna coupler is set to AUTO.
 - Carry out RT self test to check RF, PA and TX FIL boards.
 - Check that CR62 (RUN) in the antenna coupler blinks. If not, the antenna coupler CPU is defective. Carry out the self test of the antenna coupler.
- (3) When this message appears after tuning and on the specific band;
 - Check the matching circuit for no burnout.
 - Check the antenna for continuity and touching no object.
 - Check the antenna coupler for secure grounding.
 - Check that the shield of the RF coaxial cable is grounded securely to COUP board through the clamp.
 - Check that the RF connector connected to the antenna coupler is fabricated properly.
 - Check the coaxial cable connected to the antenna coupler for no corrosion and water leakage.

If the problem still exists, the antenna impedance is not matched to the specific frequency. Change the antenna length.

Trouble: RX1 PLL UNLOCK

PLL on WR1 board is unlocked. Change W/R1 board (05P0734) with new one.

Trouble: RX2 PLL UNLOCK

PLL on WR2 board is unlocked. Change W/R2 board (05P0734) with new one.

Trouble: TRX PLL UNLOCK

TRx PLL on TX/RX board is unlocked. The transmission stops except for distress alert call. Change TX/RX board (05P0732) with new one.

Trouble: DMC cable short

The RD line of IC-302-DSC port short-circuits. Check the wiring.

Trouble: BZ cable short

The BZ IN line of IC-303-DSC (Incoming Indicator) cable short-circuits. Check cable wiring.

TX POW REDUCED MAIN AMP HEATED

PA transistor on PA board is overheated. Stop the transmission.

TRx EEPROM ERROR !! Please power OFF

An error is found during EEPROM check at power-on. Turn off the system, and on it again.

TRX HD Watchdog Please power OFF

C-CPU is reset abnormally at power-on. Turn off the system, and on it again.

TRx Time Out Please power OFF

An error is found in the communication between T-CPU and C-CPU. Turn off the system, and on it again.

Print not ready

The printer does not respond.

Check that the printer is ON and the connection is tight. If it is OK, change the printer or C-CPU board.

Caution: Paper end

“Paper end” signal is received from the printer. Set new printing paper. Check that the rolled paper is in position and “Paper end” sensor works normally.

Occupied (Another controller)

Another FS-2570C is OFF HOOK.

Occupied (NBDP)

This message appears during NBDP operation.

Occupied (NBDP) WACTH

This message appears during NBDP watch.

Occupied (NBDP) Connection

NBDP line is connected.

Occupied(NBDP) CALLING

This message appears during NBDP call.

Occupied (NBDP) Disconnect

NBDP line is disconnected.

IN COMING

This message appears during the reception of DSC signal.

6.6.2 Message on NBDP terminal

CONNECTING

The line is connected.

Channel Busy Check. To forcibly transmit a call, press the ENTER key.

This message appears during channel busy check before a call. If the channel is not used, press [Enter] to start calling.

Check interconnections between terminal and Main.

No communication between the control unit and the terminal unit is made for more than 30 seconds. Check the connection.

Cannot print. Check interconnections between printer and terminal.

The printer is not ready. Check the printer connection, the paper, and the printer setting, "ON LINE".

Check interconnections between radio and Main.

RT fails to communicate with NBDP DSP.

Check interconnections between DSC and Main.

RT fails to communicate with DSC DSP.

CALLING FAILED.

The line is not connected in ARQ mode after 128 time calls (about one minute).

Station calling suspended. Check radio and interconnections.

A recall is made on the same frequency within one minute. Wait for 1 minute or more for recalling.

unknown unit

The terminal unit detects no connection of FS-1570 or FS-2570.

Write protect error

Floppy Disk is write-protected.

Drive not ready.

A floppy disk is not inserted into the floppy disk drive.

This editor cannot edit over 16kbytes.

The TEXT editor is used by more than 16 kbytes data. The text should be 16 kbytes or less.

Memory allocation error !

The TEXT editor is used by more than 16 kbytes data. The text should be 16 kbytes or less.

Modem response error.

NBDP DSP board is not installed.

Cannot write.

The data is not written onto the floppy disk. Maybe, the disk is not formatted.

File not found. '%s'

The file is not found. Check the file name.

Cannot read edit file.

The system cannot read the text in the file.

Disk full.

The floppy disk is full. Change the floppy disk.

Distress Alert Activated !.

DSC distress alert is released.

Timer operation filed.

The timer operation is failed.

Directory not found. '%s'

The specified directory is not found.

6.7 Changing Back-up battery on IB-583: TERM CPU board



CAUTION!

Take care to avoid short-circuit of the battery. This could create a burn or fire hazard. Do not dispose of battery in a fire or an incinerator; this may cause an explosion!

Type of lithium battery : CR2450-F2ST2L
Code number : 000-144-941

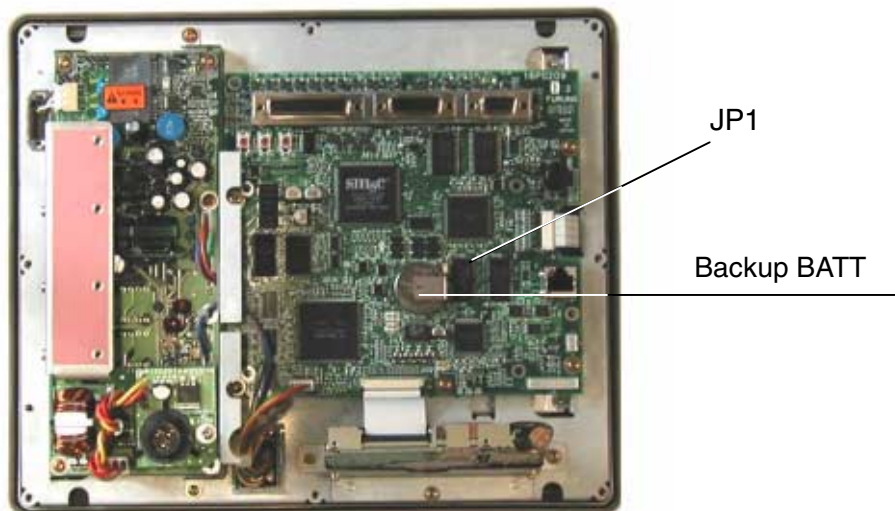

Fig.6.7.1 TERM CPU board

When the date in the [F5] and [F6] menu is cleared by power-on and off, the back-up battery should be replaced. The life of the battery is about five years.

Procedure

1. Remove TERM CPU board.
2. Remove JP1 (Back-up line) and then replace the battery.

Chapter 7. Adjustment and Measurement

7.1 Output power

7.1.1 Power Data

Output power is adjusted by setting power data for specific frequency range and emission mode as shown in Table 7.1.1. High, middle and low powers are adjusted. The output power of each user channel is preset at the registration of the user channel. The ITU channel also uses the power data in Table 7.1.1.

Table 7.1.1 Power data setting list

BAND	HI Power		MID Power		LOW Power	
	SSB (LSB)	TLX (DSC)	SSB (LSB)	TLX (DSC)	SSB (LSB)	TLX (DSC)
1.6-1.9999	●	●	●	●	●	●
2.0-2.9999	●	●	●	●	●	●
3.0-4.9999	●	●	●	●	●	●
4.0-5.9999	●	●	●	●	●	●
6.0-7.9999	●	●	●	●	●	●
8.0-11.9999	●	●	●	●	●	●
12.0-15.9999	●	●	●	●	●	●
16.0-17.9999	●	●	●	●	●	●
18.0-21.9999	●	●	●	●	●	●
22.0-24.9999	●	●	●	●	●	●
25.0-26.9999	●	●	●	●	●	●
27.0-27.4999	●	●	●	●	●	●
ITU Channel						
Same power data as band						
User Channel (RT setup – USER CH Entry: Max. 255 CH)						
0- 25 BAND	Each channel					

● : individual setting

The default setting of power data is listed in Table 7.1.2.

Table 7.1.2 Default setting of power data

Default		FS-1570T output (J3E 4 MHz)	FS-2570T output (J3E 4MHz)	Setting range
HIGH	240	150 W	250 W	0 to 255
MID	210(FS-1570) 180(FS-2570)	120 W	125 W	0 to 255
LOW	195 (FS-1570) 160 (FS-2570)	90 W	85 W	0 to 255
TUNE	90	15 W	18 W	0 to 140

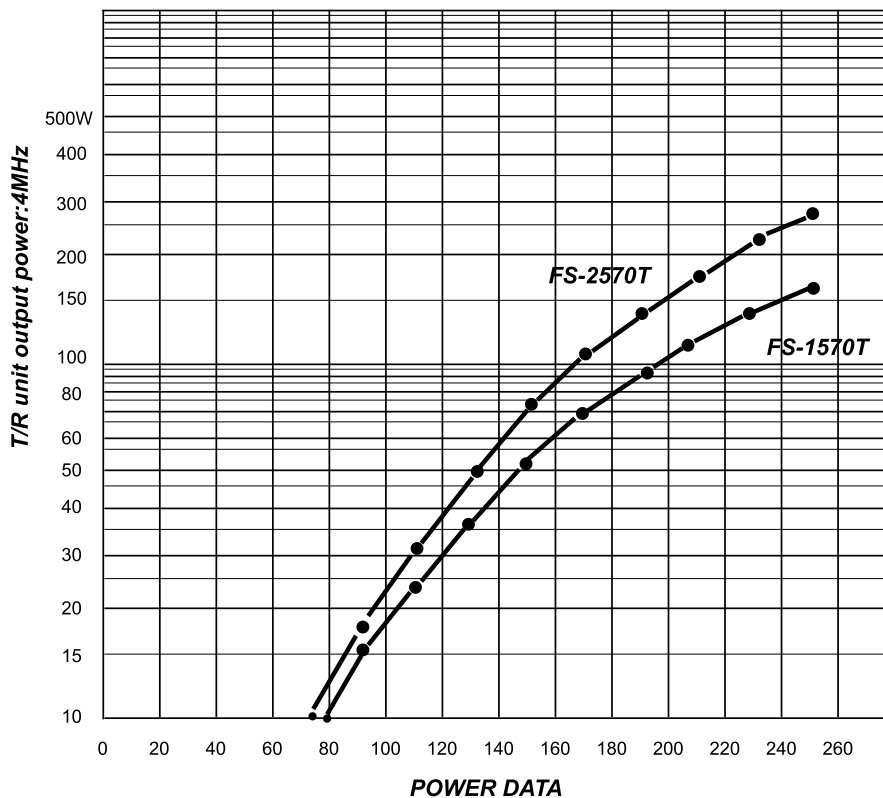

Power data vs. T/R output

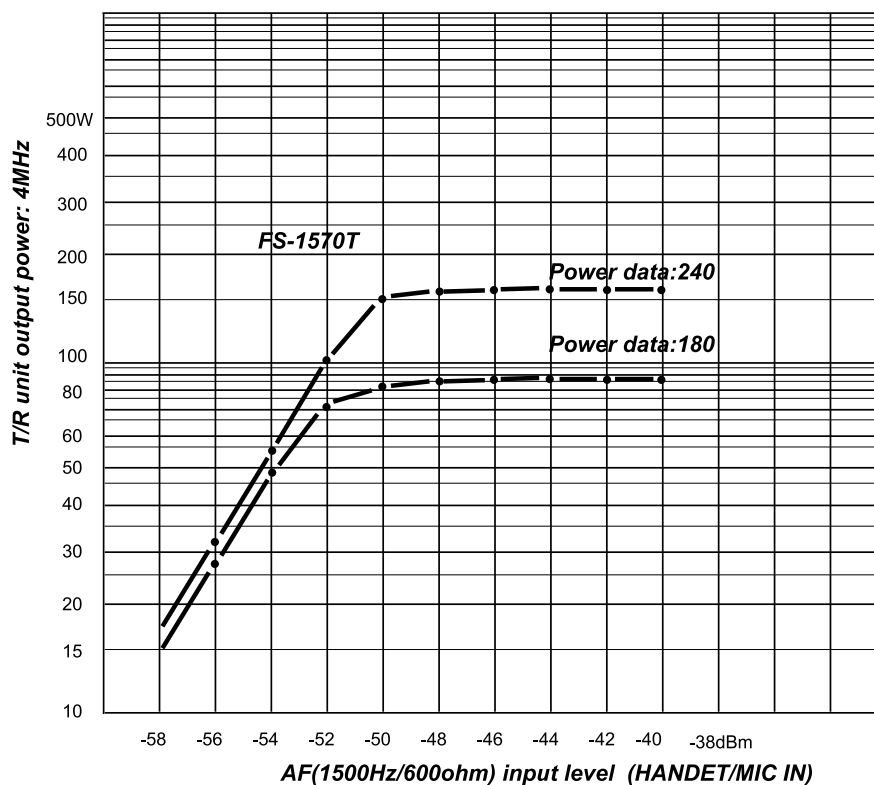

Input vs. output

7.1.2 Output power measurement

(1) Transceiver output

To measure the output power from the transceiver unit, FS-1570T and FS-2570T, connect the 50-ohm power meter and dummy load to “T/R ANT” connector as shown in Fig. 7.1.1.

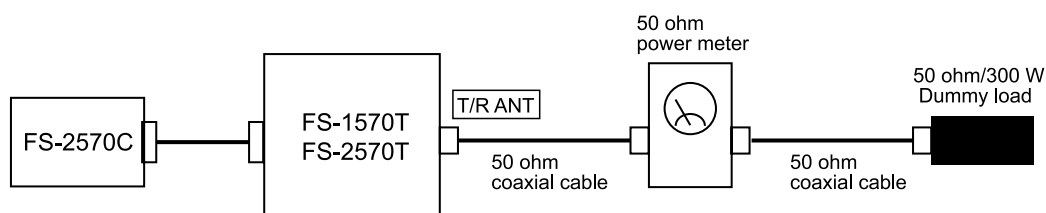

Fig.7.1.1 T/R output power measurement

(2) Antenna power

Antenna power is calculated by using the following formula with readouts of V_c and I_c on the control unit FS-2570C.

$$P_o = V_c \times I_c \times \eta$$

$$I_c = P_o / (V_c \times \eta)$$

where, η is efficiency on the factory test data.

For example, when the output power of 4 MHz signal is adjusted to 150 W, $P_o = 150$, $\eta = 40\%$, $V_c = 23.5$ V and $I_c = 150 / (23.5 \times 40) = 15.9$. Thus, I_c is set to 15.9 A.

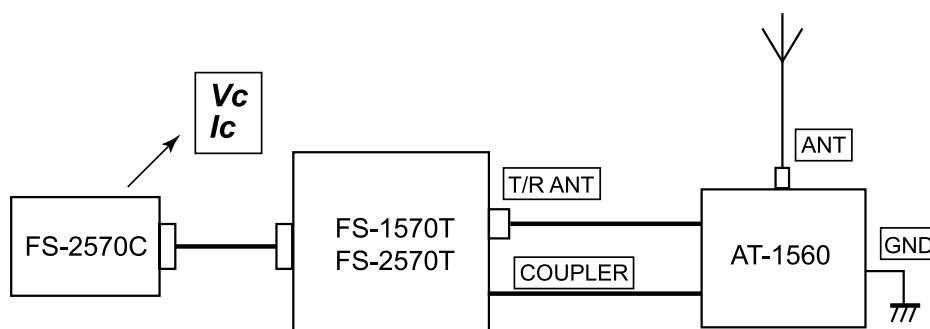

Fig.7.1.2 Measurement of antenna power

7.1.3 Adjustment of output power for operating frequency

To adjust output power for operating frequency;

1. With RT display, press [SETUP] to show Setup menu.
2. Move the cursor over SYSTEM and press [ENT]. System setup menu protected appears.
3. Enter the password, xxxxxx.
4. Select TX POWER (FREQ) by using the cursor.
5. Press [ENT] to show Tx Power setup menu.

Table 7.1.3 Tx Power setup (FREQ) menu

Item	Description	Options
TX MODE	Selects emission mode	SSB, TLX (DSC)
TX FREQUENCY	Selects operating frequency	
TX POWER	Selects output power	LOW, MID, HIGH
TX POWER ADJ	Sets power data	0 to 255
TX POWER TUNE	Sets tuning power	0 to 140
SAVE TX POWER	Saves above data	
ERASE TX POWER	Selects factory default	HIGH: 240, MID: 210(FS-1570), 180(FS-2570) LOW: 195 (1570); 160 (2570) TUNE: 90

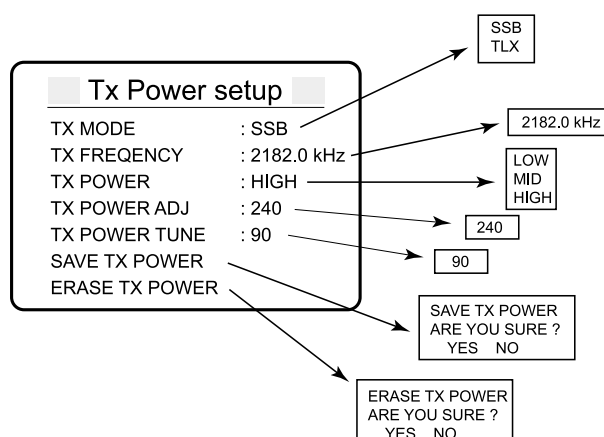

6. Select TX MODE and press [ENT]. Then, select emission mode, followed by [ENT].
7. Select TX FREQUENCY and press [ENT]. Then, enter operating frequency, followed by [ENT].
8. Set TX POWER line. (HIGH, MID or LOW)

9. Set TX POWER ADJ line. Rotate the knob or use numeric keys to enter power data. Press PTT switch for transmission. Measure the T/R output power on power meter or readout V_c and I_c then calculate output power. And then, change power data. Tx signal frequency is modulated by 1785Hz tone signal that is not concern TX MODE setting.
10. Repeat from step 6 for another operating frequency.
11. Move the cursor over SAVE TX POWER and press [ENT] to save the data.
12. Select YES and press [ENT].

Factory default setting

To select factory default;

1. Move the cursor over ERASE TX POWER and press [ENT].
2. Select YES and press [ENT].

7.1.4 Adjustment of output power for user channel

To adjust output power for user channel;

1. With RT display, press [SETUP] to show Setup menu.
2. Move the cursor over SYSTEM and press [ENT]. System setup menu protected appears.
3. Enter the password, xxxxxx.
4. Select TX POWER (USER) by using the cursor.
5. Press [ENT] to show Tx Power setup menu.

Table 7.1.4 Tx Power setup (User) menu

Item	Description	Options
TX MODE	Selects emission mode	SSB, NBDP, DSC
TX CH	Selects operating channel	
TX POWER	Selects output power	LOW, MID, HIGH
TX POWER ADJ	Sets power data	0 to 255
SAVE TX POWER	Saves above data	
ERASE TX POWER	Selects factory default	HIGH: 240 MID: 210(FS-1570), 180(FS-2570) LOW: 195 (1570); 160 (2570)

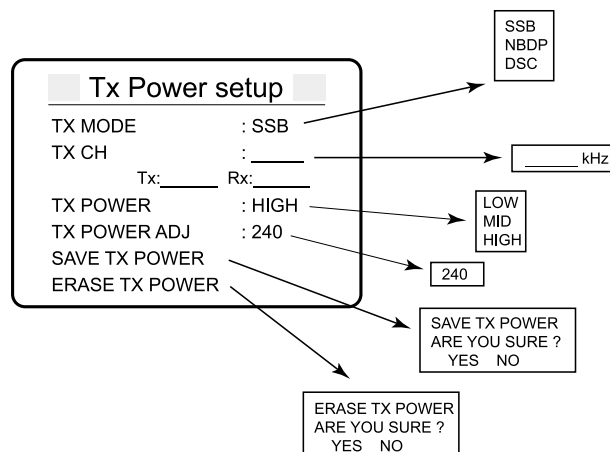

6. Select TX MODE and press [ENT]. Then, select emission mode, followed by [ENT].
7. Select TX CH and press [ENT]. Then, enter the user channel to be set, followed by [ENT]. For example, to set 2-01, type 201 followed by [ENT].
8. Set TX POWER line. (HIGH, MID or LOW)
9. Set TX POWER ADJ line. Rotate the knob or use numeric keys to select power data. Press PTT switch for transmission. Measure the T/R output power on power meter or readout V_c and I_c then calculate output power. And then, change power data. Tx signal frequency is modulated by 1785Hz tone signal that is not concern TX MODE setting.

10. Repeat from step 6 for another user channel.
11. Move the cursor over SAVE TX POWER and press [ENT] to save the data.
12. Select YES and press [ENT].

Factory default setting

To select factory default;

1. Move the cursor over ERASE TX POWER and press [ENT].
2. Select YES and press [ENT].

7.2 Frequency

CAUTION

Prior to measurement, allow crystal oscillator outputs 20 minutes or more to stabilize, and the frequency counter sufficient time to warm up.

7.2.1 Measurement of TX operating frequency

Fig.7.2.1 and Fig.7.2.2 show the connection of the frequency counter to measure the operating frequency. A coil of wire, 4 to 6 turns is coupled to the RF signal.

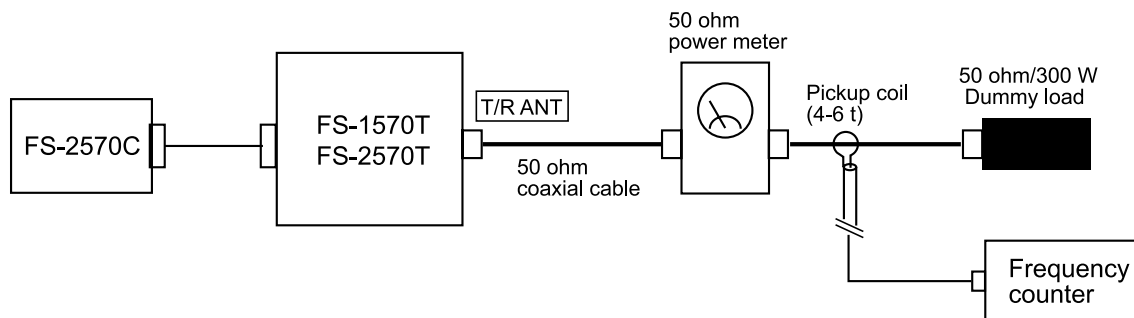

Fig.7.2.1 Measuring operating frequency at T/R ANT connector

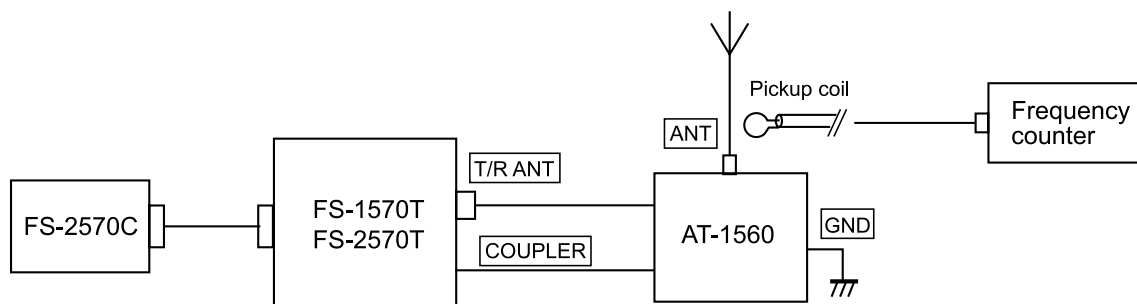

Fig.7.2.2 Measuring operating frequency at ANT connector

To measure the TX operating frequency;

1. With RT display, press [SETUP] to show Setup menu.
2. Move the cursor over SYSTEM and press [ENT]. The System setup menu protected is displayed.
3. Enter the password, xxxxxx to unlock the system menu.
4. Move the cursor over TONE and press [ENT]. "Tone Tx test" menu appears.

Table 7.2.1 Tx Power setup (User) menu

Item	Description	Options
TONE	Selects tone signal	OFF: No tone DOT: 1700±85Hz MARK: 1700Hz – 85 Hz SPACE: 1700Hz + 85 Hz
TX FREQ	Selects operating frequency	
MODE	Selects mode	SSB, TLX
TX KEY	Tx key ON/OFF	ON/OFF
DSP	Select DSP Select either DSC or NBDP DSP board for tone signal output.	DSC, NBDP

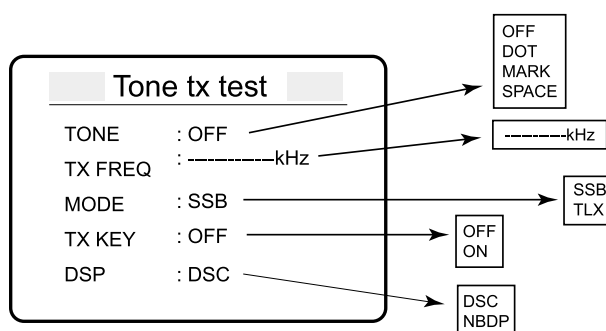

5. Set TONE line. (OFF, DOT, MARK, and SPACE)
6. Set TX FREQ line.
7. Set MODE line.
8. Set DSP line.
9. Set TX KEY to ON, and press [ENT].
10. Read the frequency on the frequency counter.

Table 7.2.2 Frequency deviation

Frequency	Mode	Tone signal	Operating Freq.	Freq. error
Fo	SSB	MARK	Fo + 1615 Hz	Within ±10 Hz
		SPACE	Fo + 1785 Hz	
	TLX	MARK	Fo - 85 Hz	
		SPACE	Fo + 85 Hz	

11. Set TX KEY to OFF to terminate the transmission.
12. Repeat from step 6 to measure the frequency of another operating frequency.

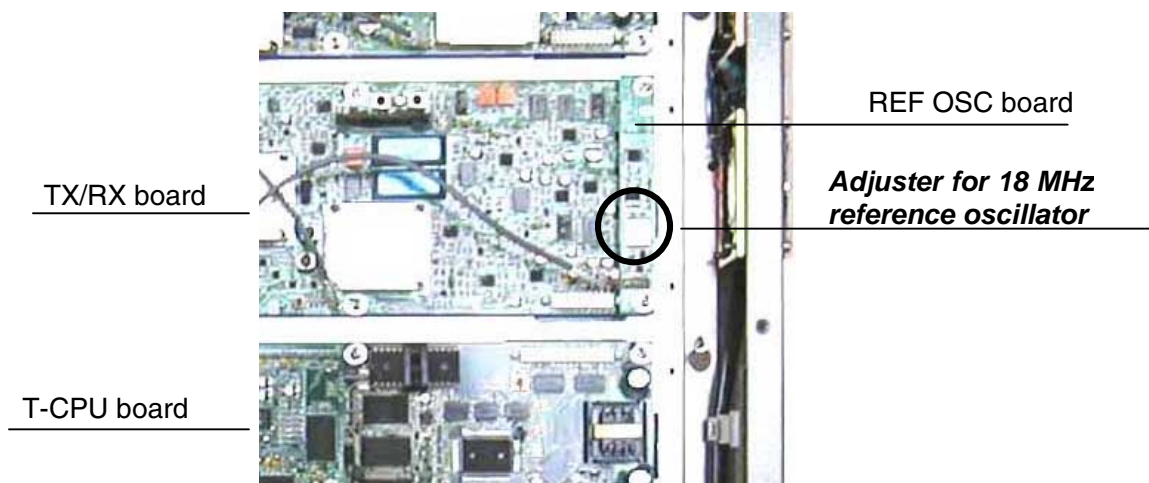

Fig.7.2.3 Frequency adjustment

7.2.2 Tone frequency

The frequency of mark and space tones is measured at TP4 on DSC DSP board and NBDP DSP board, 05P0751.

Mark = 1785 Hz ± 0.5 Hz

Space = 1615 Hz ± 0.5 Hz

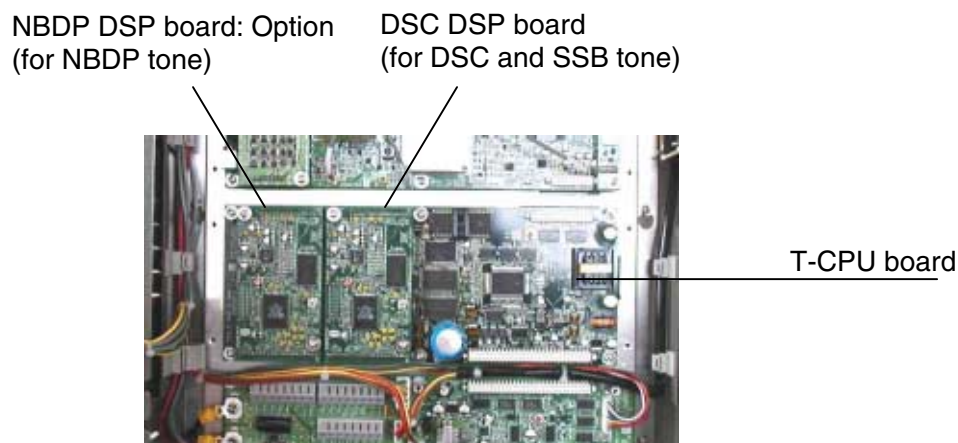

Fig.7.2.4 Location of DSP board



Fig.7.2.5 DSP board

To measure tone frequency;

1. With RT display, press [SETUP] to show Setup menu.
2. Move the cursor over SYSTEM and press [ENT]. The System setup menu protected is displayed.
3. Enter the password, xxxxxx to unlock the system menu.
4. Move the cursor over TONE and press [ENT]. Tone Tx test menu appears.
5. Move the cursor over TONE and press [ENT].
6. Select either MARK or SPACE, followed by [ENT].
7. Move the cursor over DSP and press [ENT].
8. Select either "DSC" board or "NBDP" board, followed by [ENT]. For example, select "DSC".
9. Connect the frequency counter to TP4 on the DSC board selected.
10. Move the cursor over TX KEY and press [ENT].
11. Read the frequency on the counter.

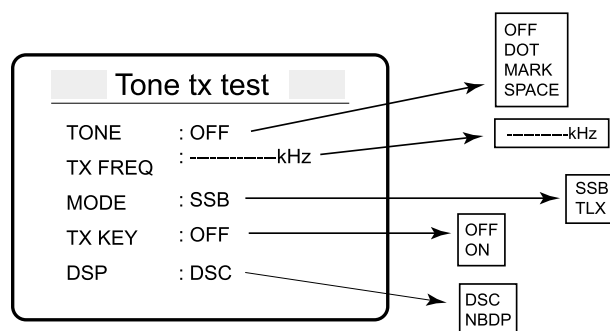

If the frequency is not within the rating, check and adjust the frequency of the crystal oscillator on DSP board.

Table 7.2.3 Adjustment of the frequency of the crystal oscillator on DSP board

	TP	Adjuster	Rating
Y1 (5.1200 MHz)	TP2	C4	2.56 MHz \pm 2 Hz
Y2 (11.8040 MHz)	TP16	C45	23.608 MHz \pm 10 Hz

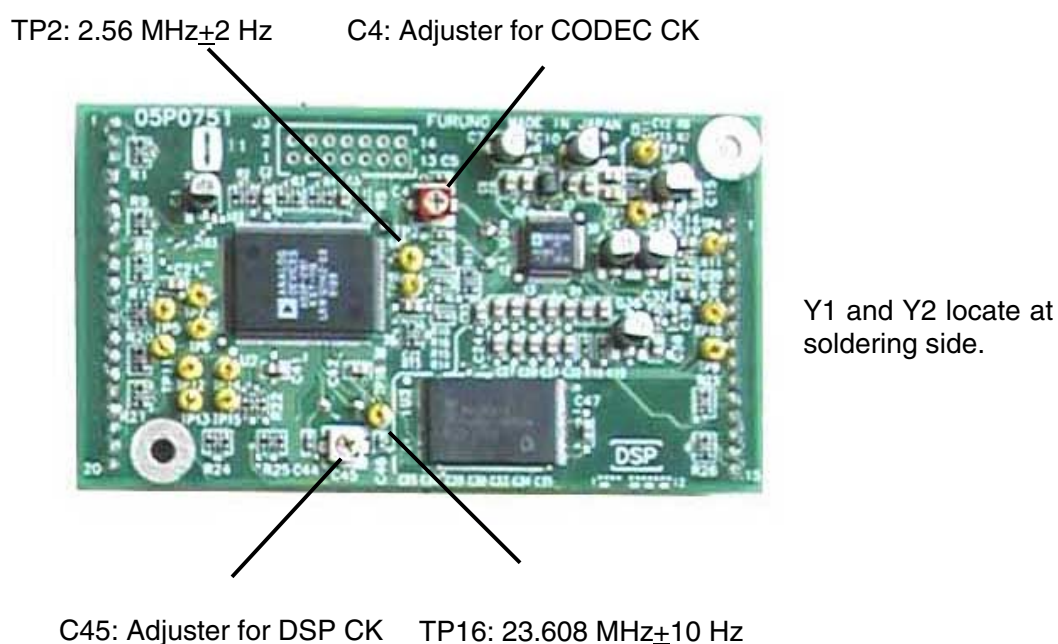

Fig.7.2.6 DSP board

These clocks are used as follows.

DSC DSP board

Y1: Clock for CODEC, DSC Tone and SSB Tone

Y2: Clock for DSP

NBDP DSP board

Y1: Clock for NBDP and NBDP Tone

Y2: Clock for DSP and Timing clock for NBDP communication (TX/RX)

7.3 PA Bias

PA bias is adjusted after replacing PA transistor on PA and DRV boards. The adjustment is made with PA IN connector disconnected.

Board	Model	Meter Connection	Adjuster	Rating
PA (05P0735)	FS-1570T	Cut L4 and connect an ammeter across L4.	R25	200 mA
DRV (05P0738)	FS-2570T	Cut L4 and connect an ammeter across L4.	R25	100 mA
PA (05P0739)		Cut L1 and connect an ammeter across L1.	R16	200 mA

(1) 05P0735 board (PA, FS-1570T)

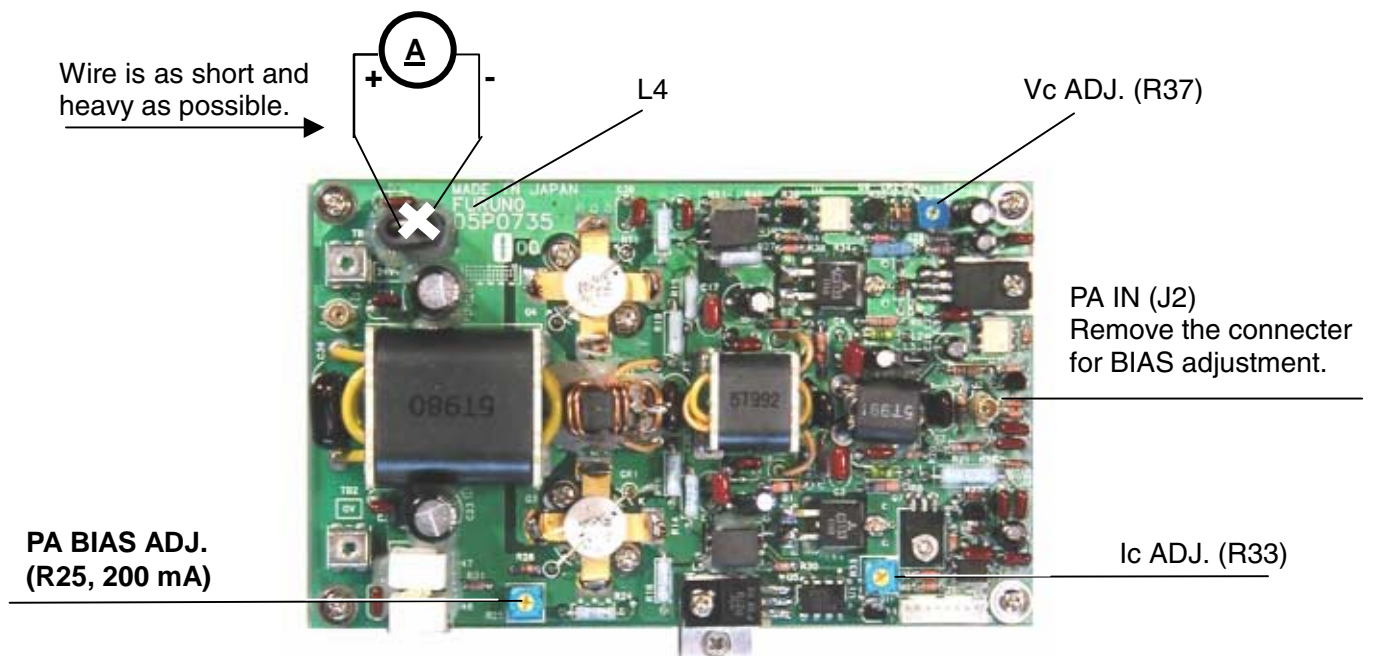

Fig.7.3.1 150 W PA, 05P0735

R33 (Ic ADJ): Collector current of the PA is adjusted by R33 so that the readout of Ic at output power adjustment is equal to the actual collector current.

R37 (Vc ADJ): Collector voltage of the PA is adjusted by R37 so that the readout of Vc at output power adjustment is equal to the actual collector voltage.

(2) 05P0739 board (PA, FS-2570T)

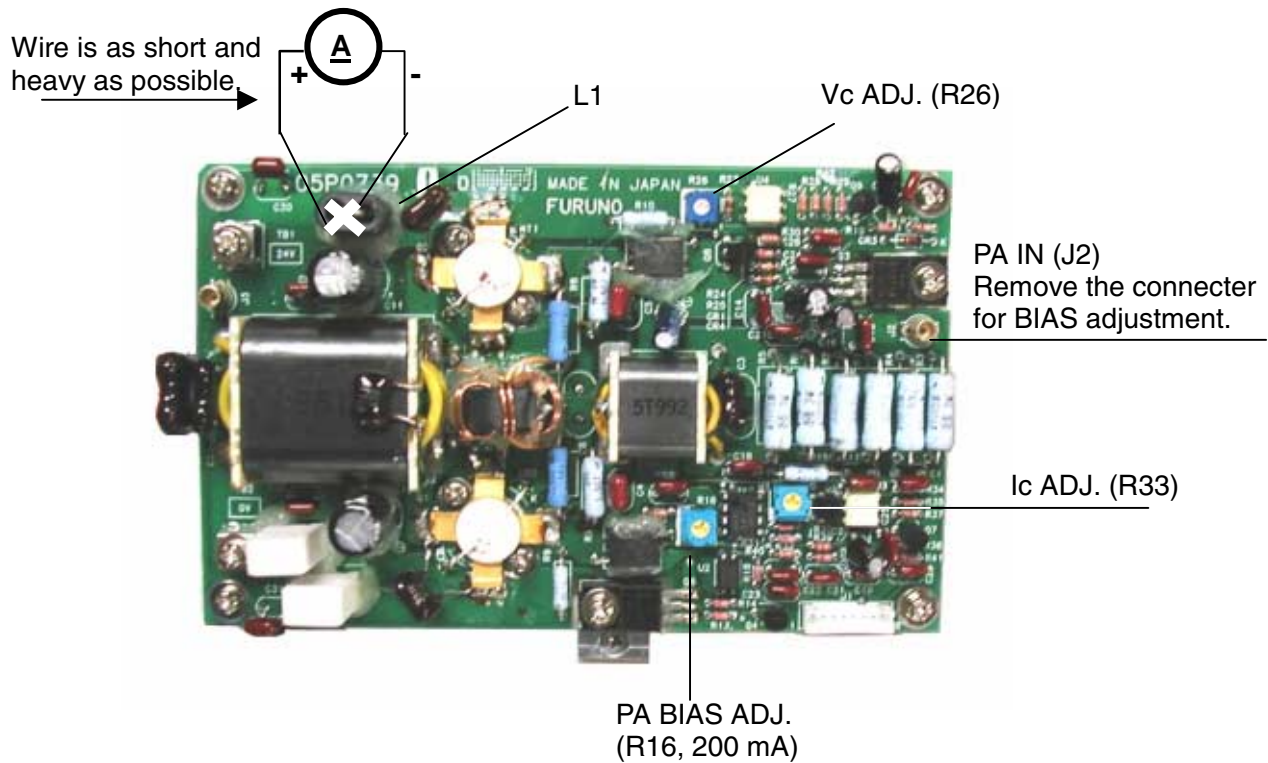

Fig.7.3.2 250 W PA, 05P0739

R26 (Vc ADJ): Collector voltage of the PA on PA-1 board is adjusted by R26 so that the readout of Vc at output power adjustment is equal to the actual collector voltage. To adjust R26 on PA-2 board, exchange the connection of J4 and J5 on the TX FIL board.

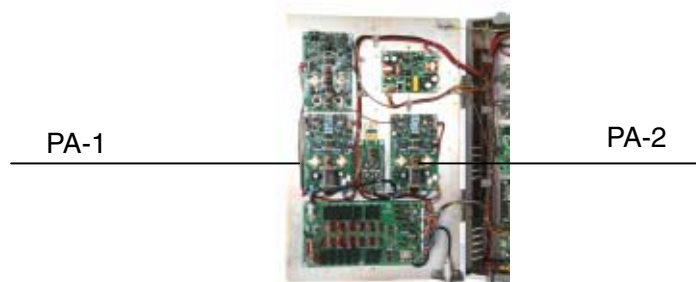

Fig.7.3.3 Location of PA-1 and PA-2

R33 (Ic ADJ): Collector current of the PA is adjusted by R33 so that the readout of Ic at output power adjustment is equal to the actual collector current. This adjustment is made with J2 disconnected on either PA board. The sum of both collector currents is indicated in the display.

(3) 05P0738 board (DRV, FS-2570T)

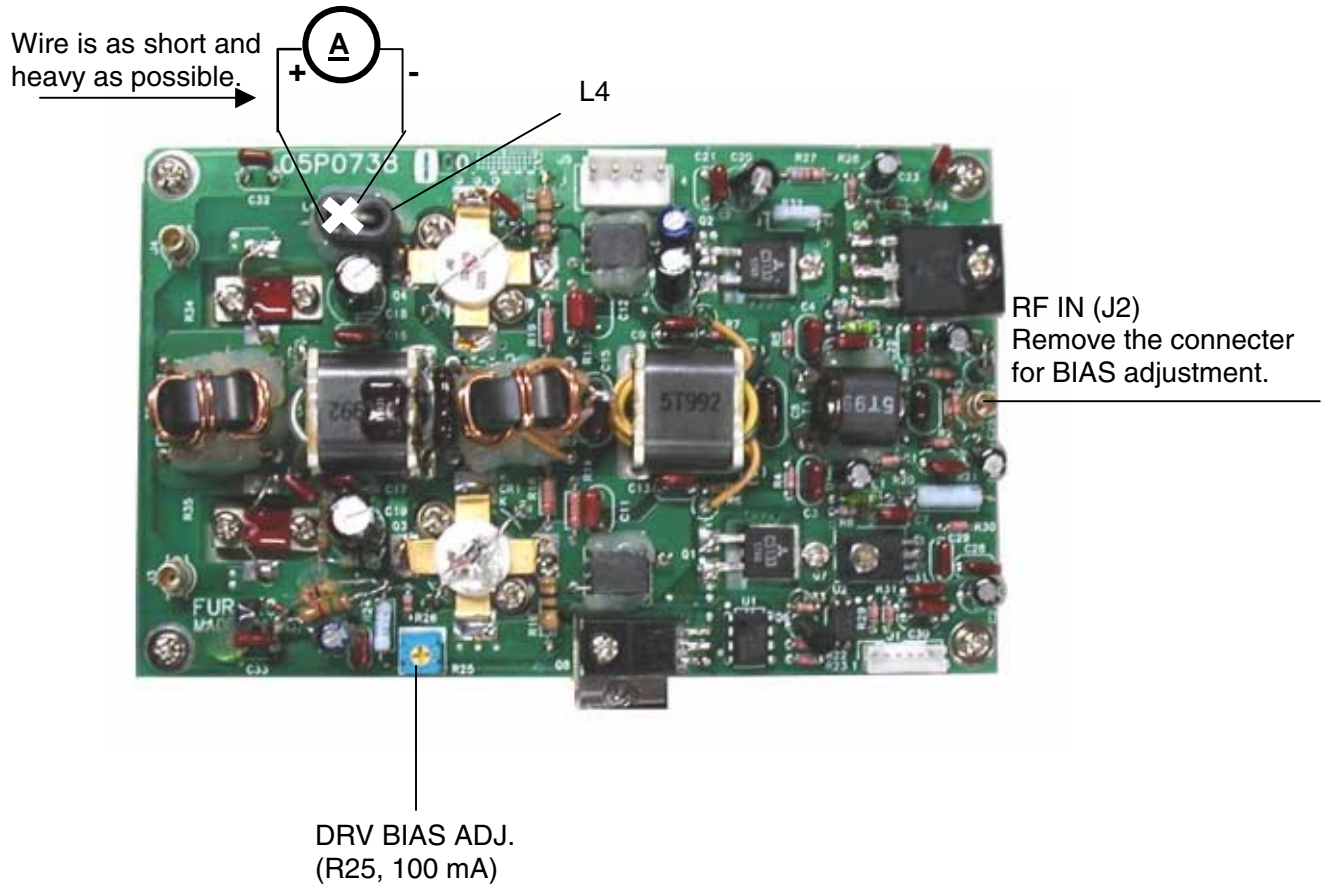

Fig.7.3.4 250 W DRV, 05P0738

Specification of PA transistors

Specifications of PA transistors are tabulated below.

Table 7.3.1 Specification of SD1405

** FS-2570 - DRV board: PA Tr **

Symbol	Parameter	Value	Unit
V_{CBO}	Collector-Base Voltage	36	V
V_{CEO}	Collector-Emitter Voltage	18	V
V_{BEO}	Emitter-Base Voltage	4.0	V
I_c	Device Current	20	A
P_{DISS}	Power Dissipation	270	W
T_J	Junction Temperature	+200	deg
T_{STG}	Storage Temperature	-65 to +150	deg

Table 7.3.2 Specification of SD1407

** FS-2570 and FS-1570 - PA board: PA Tr **

Symbol	Parameter	Value	Unit
V_{CBO}	Collector-Base Voltage	65	V
V_{CEO}	Collector-Emitter Voltage	36	V
V_{BEO}	Emitter-Base Voltage	4.0	V
I_c	Device Current	20	A
P_{DISS}	Power Dissipation	270	W
T_J	Junction Temperature	+200	deg
T_{STG}	Storage Temperature	-65 to +150	deg

Table 7.3.3 Specification of 2SC3133

** FS-2570 - DRV board: DRV Tr, FS-1570 - PA board: DRV Tr **

Symbol	Parameter	Value	Unit
V_{CBO}	Collector-Base Voltage	60	V
V_{CEO}	Collector-Emitter Voltage	25	V
V_{BEO}	Emitter-Base Voltage	5	V
I_c	Device Current	6	A
P_C	Power Dissipation	20	W
T_J	Junction Temperature	+150	deg
T_{STG}	Storage Temperature	-55 to +150	deg

7.4 TX Gain

TX gain is adjusted by using the potentiometers tabulated below. Weak audio is often caused by the transmitter gain being set too low. Excessive pickup of background noise is often caused by the microphone gain being set too high. See Fig. 7.5.2 for the location of the adjusters.

Table 7.4.1 TX Gain Adjusters

Item	Condition	Measurement	Adjuster	Rating
LINE IN signal	*Input to HANDSET/MIC connector: 1500 Hz, -46 dBm, 600 ohms *TX frequency: 25 MHz SSB *Power data: 240	Pins #7 and #8 of J5 on T-IF board (LINE-H line of CONT-1 connector)	R11 on C-IF	-10 dB/600 ohms
ALC signal		T/R ANT connector	R76 on TX FIL	1570: 150 W 2570: 250 W
Microphone gain	*Input to HANDSET/MIC connector: 1500 Hz, -55 dBm, 600 ohms *TX frequency: 25 MHz SSB *Power data: 240	T/R ANT connector	R209 on TX/RX	-1570: about 40 W -2570: about 65 W

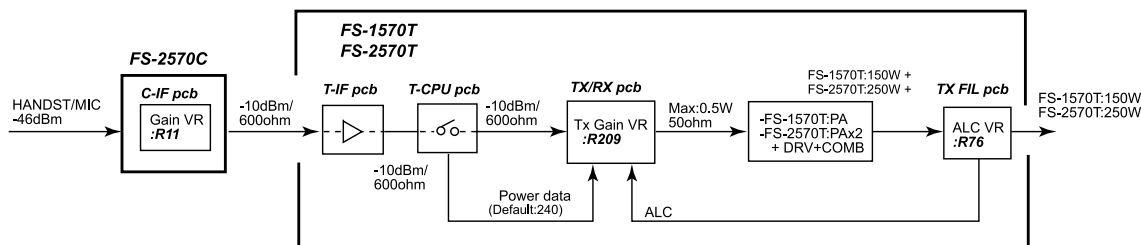

Fig.7.4.1 TX signal flow

Fig.7.4.2 shows proper microphone gain adjustment.

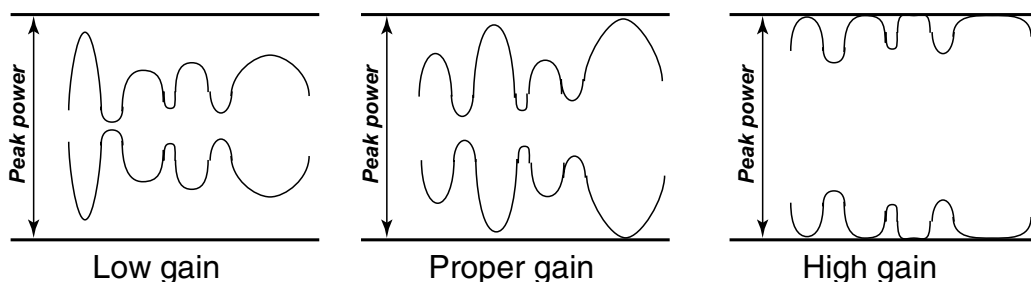

Fig.7.4.2 Microphone gain adjustment

7.5 RX Gain

Receiver gain is checked with a SSG connected to J1 (RX IN) connector on TX/RX board. See Fig. 7.5.1.

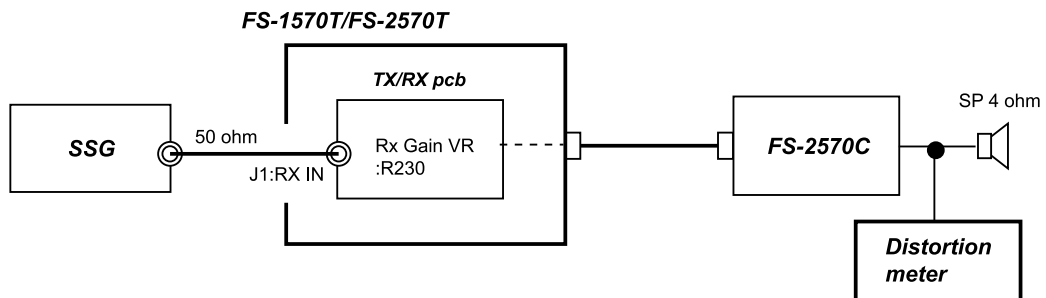

Fig.7.5.1 RX signal flow

Table below shows the ratings. The receiving signal is attenuated by PRESEL board 2 to 3 dB. If the distortion meter is not available, use a vacuum tube voltmeter. S/N (20 dB) is about $20 \log_{10} V_{\text{signal}}/V_{\text{noise}}$. Adjust AF gain volume with AGC on so that noise level from the speaker is 100 mVrms. Adjust SSG level to obtain the 1 V AF output level to speaker. When the SSG level is +3 dBuV or less, the receiver gain is normal. See Fig. 7.5.3 for the location of the adjuster.

Table 7.5.1 TX Gain Adjusters

Check Item	Condition	Rating	Adjuster
J3E receiver total gain (SSG level to obtain 4W speaker output)	4 MHz, J3E AF and RF gain controls: Maximum AGC: ON SSG output: F + 1 kHz	0 dBuV \pm 3 dBuV	None
J3E 20 dB SINAD (SSG level for 20 dB distortion), or J3E 20 dB S/N (SSG level for S/N ratio of 20 dB)	4 MHz, J3E AF gain control: Midturn RF gain control: Maximum AGC: ON SSG output: F + 1 kHz	+3 dBuV or less	None
J3E AGC minimum level (same as S meter)	4 MHz, J3E AF gain control: Adjusted RF gain control: Maximum AGC: ON (Fast) SSG output: F + 1 kHz	+10 dBuV \pm 2 dBuV	R320 on TX/RX

RX/TX gain adjustment

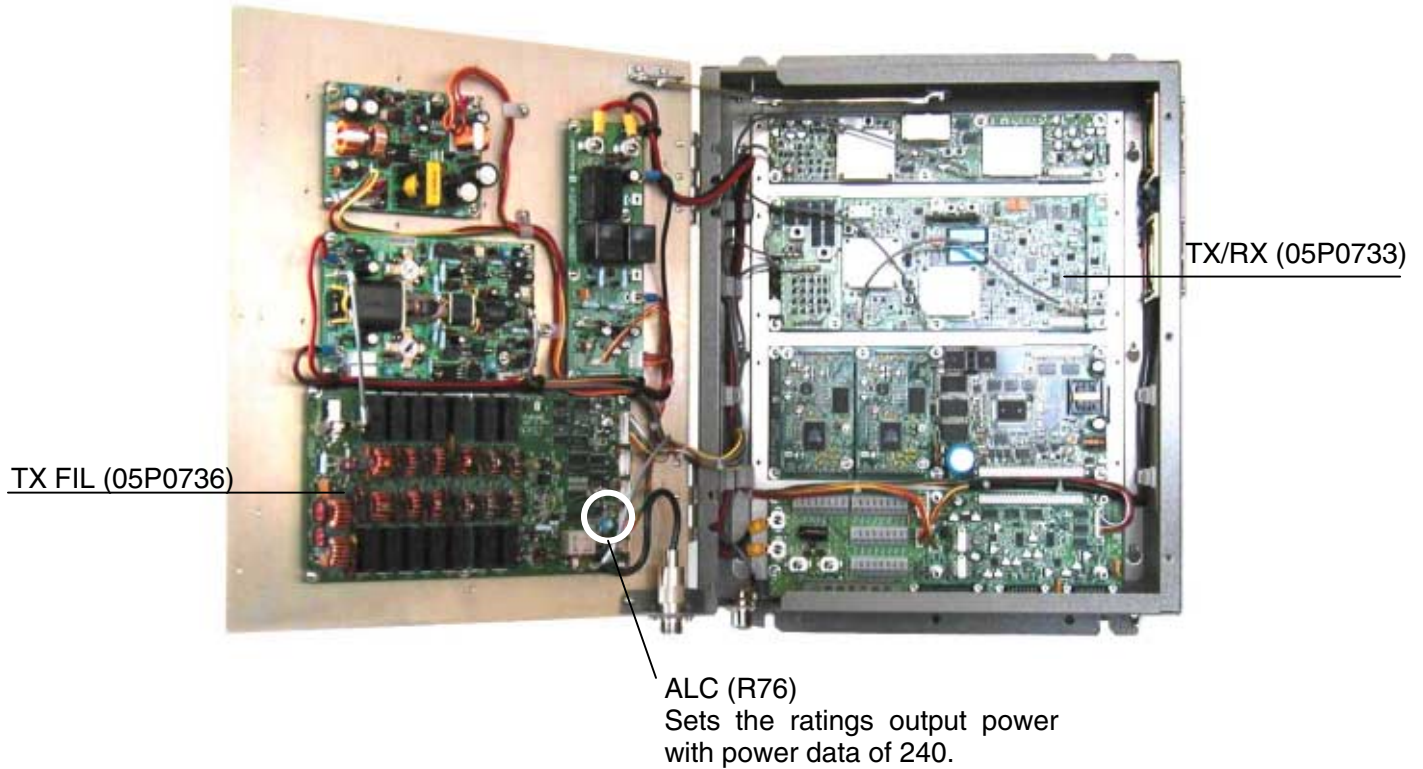

Fig.7.5.2 Location of TX gain adjusters (FS-1570T)

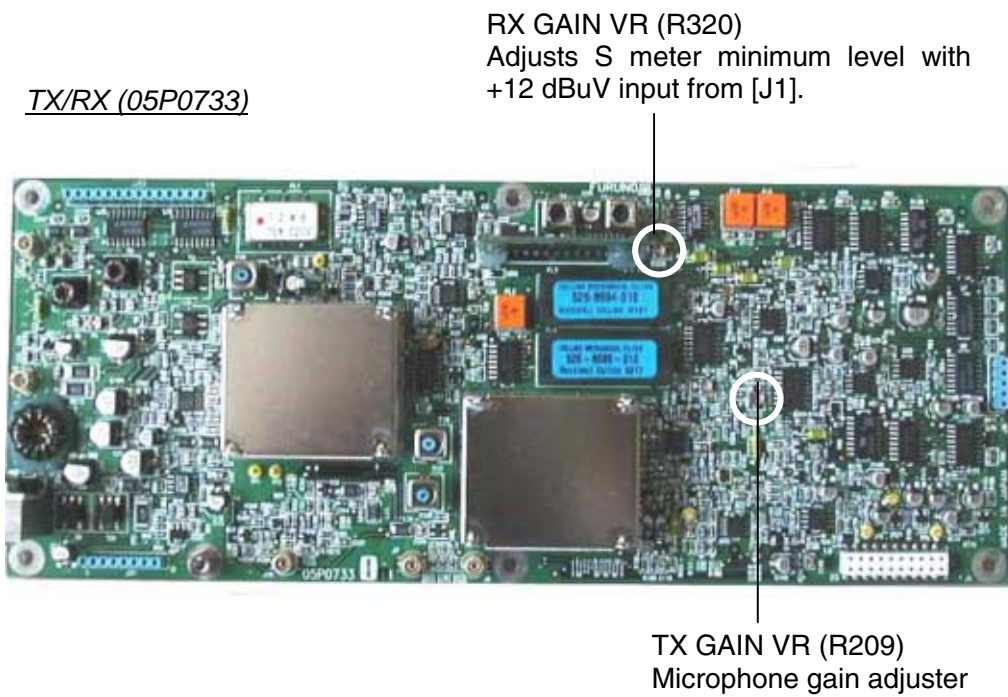

Fig.7.5.3 Location of RX gain adjuster

Appendix 1) DSC Frequency List

TX (kHz)	RX (kHz)	Remarks	File name
2187.5	2187.5	Distress and safety Frequency	
4207.5	4207.5		
6312.0	6312.0		
8414.5	8414.5		
12577.0	12577.0		
16804.5	16804.5		
458.5	455.5	International Frequency	INTL-0.4M
2189.5	2177.0		INTL-2M
4208.0	4219.5		INTL-4M
6312.5	6331.0		INTL-6M
8415.0	8436.5		INTL-8M
12577.5	12657.0		INTL-12M
16805.0	16903.0		INTL-16M
18898.5	19703.5		INTL-18M
22374.5	22444.0		INTL-22M
25208.5	26121.0		INTL-25M
4208.5	4220.0	Local-1 Frequency	LOCAL1-4M
6313.0	6331.5		LOCAL1-6M
8415.5	8437.0		LOCAL1-8M
12578.0	12657.5		LOCAL1-12M
16805.5	16903.5		LOCAL1-16M
18899.0	19704.0		LOCAL1-18M
22375.0	22444.5		LOCAL1-22M
25209.0	26121.5		LOCAL1-25M
4209.0	4220.5	Local-2 Frequency	LOCAL2-4M
6313.5	6332.0		LOCAL2-6M
8416.0	8437.5		LOCAL2-8M
12578.5	12658.0		LOCAL2-12M
16806.0	16904.0		LOCAL2-16M
18899.5	19704.5		LOCAL2-18M
22375.5	22445.0		LOCAL2-22M
25209.5	26122.0		LOCAL2-25M

Note: The DSC frequency for Ship-to-ship general calling is 2177.0 kHz for both TX and RX.

Appendix 2) DSC and NBDP Test Calls

AP2.1 DSC Test Call

Test calls should be transmitted by the ship station and acknowledged by the called coast station. Normally there would be no further communications between the two stations involved.

DSC Test Call is made with a coast station on a distress and safety calling frequency in “SAFETY” category as below.

1. Create the message as follows. See next page for the location of the coast stations and their MMSI.

CALL TYPE: TEST

ADDRESS: 00xxxxxxx (MMSI of the coast station to be called)

DSC FREQUENCY: Select the distress and safety calling frequency from 2 MHz to 16 MHz depending on the communication distance.

- When the distance is within 200 NM: 2 MHz
- When the distance is more than 200 NM: 8MHz
(The 8MHz band may in many cases be an appropriate first choice.)

Compose message	
CALL TYPE	: TEST
COAST ID	: 00xxxxxxx
PRIORITY	: SAFETY
<hr/>	
DSC FREQ	: 8414.5 kHz
GO TO ALL VIEW	

2. Press [CALL].
The transmission starts with the message “Test call in progress!” on the display.
3. After transmission, the system waits for the reply from the coast station, displaying the message “Waiting for test Acknowledge”.
4. When receiving the reply from the coast station, the message “Test acknowledge call received” appears. Test call is complete after checking the received message.
5. When not receiving the replay within 5 minutes, the message “No response! Try calling again?” appears. In this case, select another frequency and retry Test Call.

Operational HF DSC Stations with MMSI numbers for Sea Areas A3 and A4

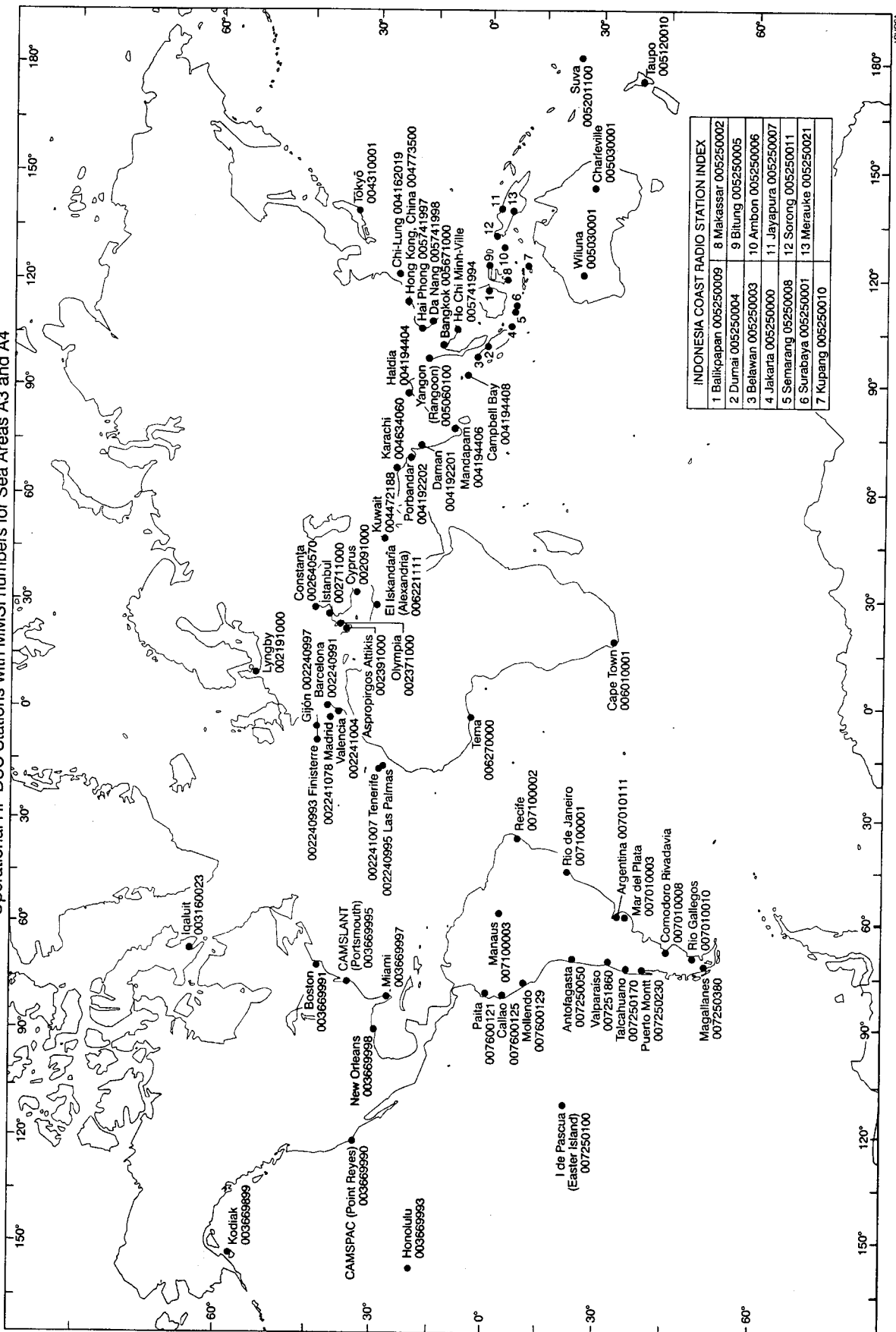

AP2.2 NBDP test

To test the NBDP, receive Maritime Safety Information and make a ARQ communication.

AP2.2.1 Receiving MSI (Maritime safety Information)

To receive the MSI, follow the steps below.

1. Check that the receiving mode is set to “AUTO” on the NBDP terminal.
Menu operation: [F3][6]: Manual Reception
2. Check that **Print** appears on the display, showing the terminal is in Print mode. If not, set Real Time Printing to ON.
Menu operation: [F1][6]: Real Time Printing
3. Set the RF gain to the maximum.
4. Enter the receiving frequency from the NBDP terminal.
Menu operation: [F3][9]: Set Frequency
“Occupied (NBDP)” appears in the RT display.
5. The message is automatically received and printed at the scheduled time.
6. If the message is received normally, the NBDP works normally.

Note: “*” mark in the received message means the letter cannot be reproduced.

Write down the station which provides the MSI service in your area.

Station name (Place)	C.S	Frequen cy	Broadcasting time (UTC)	Broadcasting contents
Shanghai Radio (China)	XSG	4215 6326 8430 8433 12649.5 16892	1145, 1445, 1745, 2045 0245, 0545, 0845 0245, 0545, 0845, 1145 1445, 1745, 2045 0245, 0545, 0845, 1145, 1445, 1745, 2045 0545, 0845, 1145, 1445	NAV
Mariana Island (U.S.A)	NRV	12579 16806.5 22376	1500, 1900, 2315 0230, 0500, 0900	NAV MET
Honolulu, Hawaii Radio	NMO	8416.5 12579 22376	0130, 0730, 1330, 2030, 0130, 2030	MET NAV
Cape Town Radi (S.A)	ZSC	4214 6322 8431.5 12601 16816 19692.5	0930, 1730	MET NAV
Rio de Janeiro Naval Radio (BRAZIL)	PWZ	6448 12709 16974	0600, 1845 0400, 0445, 2130, 2215	MET NAV

AP2.2.2 ARQ communication

To test the NBDP, make a call to a coast station which handles public correspondence call in ARQ mode. The test call is made automatically (“TEST+” and “HELP+” commands) or manually (“OPR+” command).

1. Check that the receiving mode is set to “AUTO” on the NBDP terminal.
Menu operation: [F3][6]: Manual Reception
2. Check that **Print** appears on the display, showing the terminal is in Print mode. If not, set Real Time Printing to ON.
Menu operation: [F1][6]: Real Time Printing
3. Set the RF gain to the maximum.
4. Enter the transmission and receiving frequency from the NBDP terminal.
Menu operation: [F3][9]: Set Frequency
“Occupied (NBDP)” appears in the RT display.
5. Set the “MODE” to ARQ and enter “ID” for the coast station. (Menu operation: [F3][8]: Manual Calling)
6. Press [Enter]. “Cannel Busy Check. To forcibly transmit a call, press the ENTER key.” appears. Check that the channel is not in use and press [Enter] to start calling.
7. When the coast station replays, the AAB is exchanged automatically, and the “GA+” is received.
8. Type “TEST+” or “HELP+”.
9. The coast station automatically transmits the message.
10. The NBDP should receive the message normally. Press [F10] (Break) to stop the communication.

Write down the station in your area for test call.

Station name (Place)	C.S (ID)	ITU-CH (Only H24)	Remarks
Hong-Kong Radio	VRX (1480)	811, 1213, 1630	Command for test: FREQ+, HELP+, TEST OPR+

Appendix 3)

Cancelling and receiving distress alert

AP3.1 Cancelling distress alert

When sending the false distress alert, the sender must notice to the interested organization that the false distress alert is sent and cancelled.

The ships received the false distress alert do not need any action.

MF band

1. Switch off equipment immediately.
2. Switch equipment on and tune for radiotelephony transmission on 2182kHz.
3. Make broadcast to “All Stations” giving the vessel’s name, callsign and DSC number, and cancel the false distress alert.

Example

All Stations, All Stations, All Stations

This is NAME, CALLSIGN,

DSC NUMBER, POSITION.

Cancel my distress alert of

DATE, TIME, UTC.

= Master NAME. CALLSIGN.

DSC NUMBER. DATE. TIME UTC.

HF band

As for MF but the alert must be cancelled on all the frequency bands on which it was transmitted. Hence, the transmitter should be tuned consecutively to the radiotelephony distress frequencies in the 4, 6, 8, 12 and 16 MHz bands, as necessary.

	DSC	Telephone (J3E)
MF	2187.5 kHz	2182 kHz
HF	4207.5 kHz	4125 kHz
	6312 kHz	6215 kHz
	8414.5 kHz	8291 kHz
	12577 kHz	12290 kHz
	16804.5 kHz	16420 kHz

AP3.2

See next pages for the actions by ships upon reception of DSC distress alert.

ACTIONS BY SHIPS UPON RECEPTION OF VHF/MF DSC DISTRESS ALERT

COMSAR/Circ.25 ANNEX
FLOW DIAGRAM 1

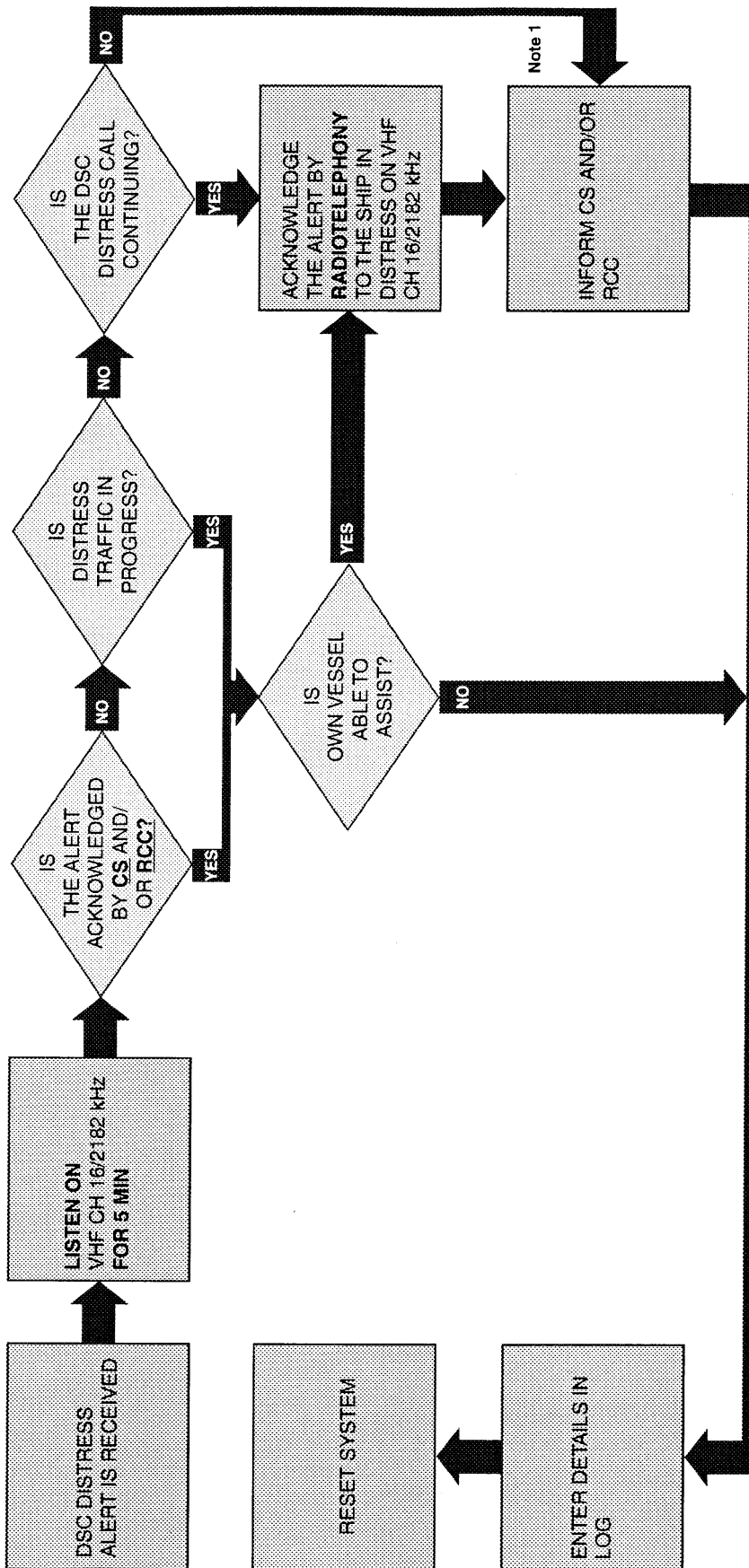

REMARKS:

NOTE 1: Appropriate or relevant RCC and/or Coast Station shall be informed accordingly. If further DSC alerts are received from the same source and the ship in distress is beyond doubt in the vicinity, a DSC acknowledgement may, after consultation with an RCC or Coast Station, be sent to terminate the call.

NOTE 2: In no case is a ship permitted to transmit a DSC distress relay call on receipt of a DSC distress alert on either VHF channel 70 or MF channel 2187.5 kHz.

CS=Coast Station

RCC=Rescue Co-ordination Center

FURUNO ELECTRIC CO., LTD.

ACTIONS BY SHIPS UPON RECEPTION OF HF DSC DISTRESS ALERT

COMSAR/Circ.25 ANNEX
FLOW DIAGRAM 2

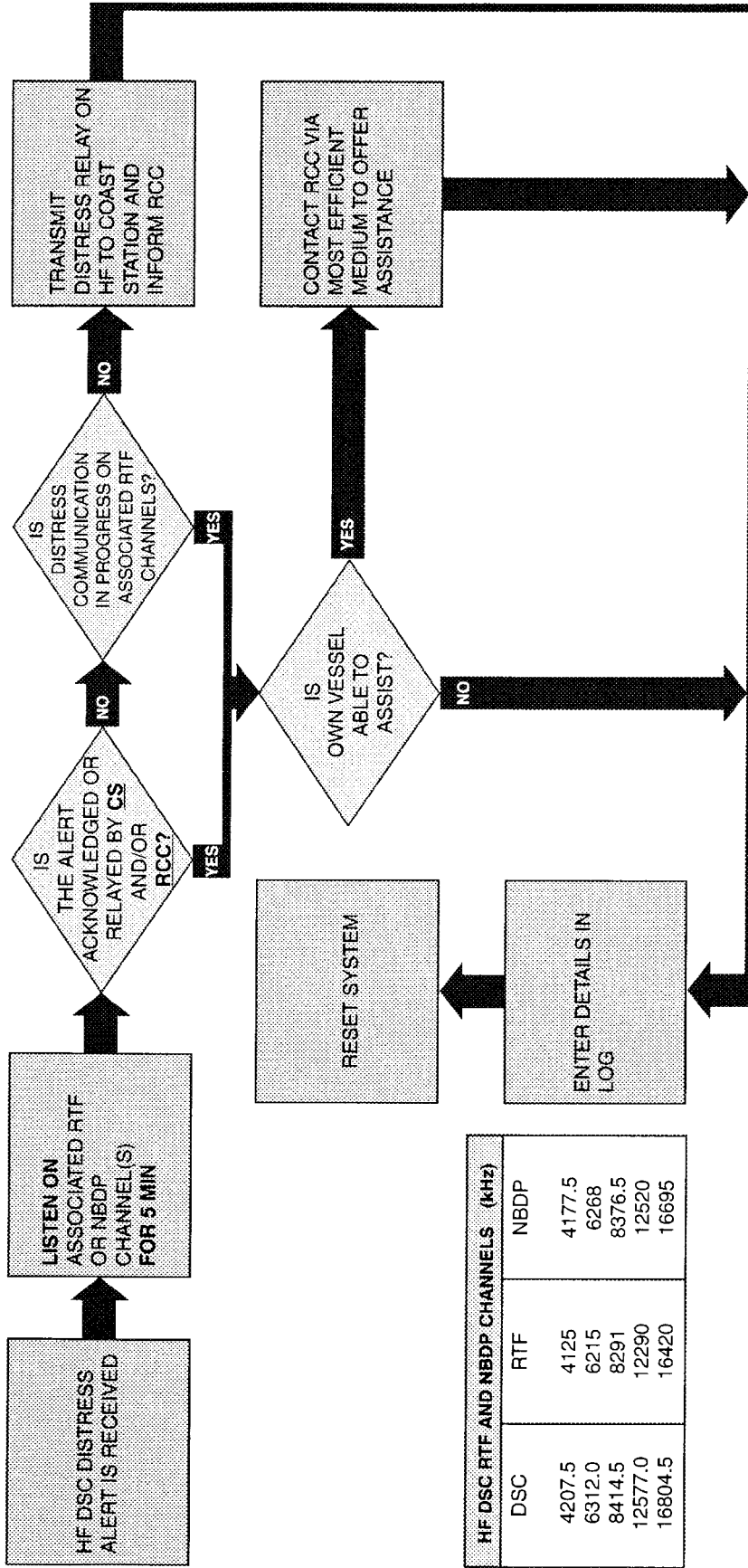

HF DSC RTF AND NBDP CHANNELS (kHz)		
DSC	RTF	NBDP
4207.5	4125	4177.5
6312.0	6215	6268
8414.5	8291	8376.5
12577.0	12290	12520
16804.5	16420	16695

REMARKS:

- NOTE 1: If it is clear the ship or persons in distress are not in the vicinity and/or other crafts are better placed to assist, superfluous communications which could interfere with search and rescue activities are to be avoided. Details should be recorded in the appropriate logbook.
- NOTE 2: The ship should establish communications with the station controlling the distress as directed and render such assistance as required and appropriate.
- NOTE 3: Distress relay calls should be initiated manually.

RCC=Rescue Co-ordination Center FURUNO ELECTRIC CO., LTD.

Appendix 4) Specifications

1 MF/HF DIGITAL RADIOTELEPHONE

1.1 GENERAL

- 1.1.1 Communication System Semi-duplex or simplex
- 1.1.2 Class of Emission J3E: Telephone
J2B (F1B): DSC or NBDP
H3E: reception only
- 1.1.3 Frequency Range 100.00 kHz to 29,999.99 kHz
- 1.1.4 Number of Channel User programmable: 255 TX/RX pairs
All ITU channels incorporated (include DSC/NBDP channels)
2182 kHz (single action)
- 1.1.5 Display Method Monochrome LCD (120 x 64 dots)
- 1.1.6 Backlight 8 tones
- 1.1.7 Contrast 64 steps
- 1.1.8 Warming up 1 minute approx. (oven 20 minutes approx.)

1.2 TRANSMITTER

- 1.2.1 Frequency Range 1,606.5 kHz to 27.5 MHz (100 Hz steps)
- 1.2.2 RF output Power FS-1570: 150 Wpep, FS-2570: 250 Wpep
- 1.2.3 Frequency Resolution Within ± 10 Hz
- 1.2.4 Modulation AF Response 350 Hz to 2.7 kHz
- 1.2.5 Modulation System Low power balanced modulation
- 1.2.6 AF Input -46 dBm/600 ohms (Handset/Microphone)
-10 dBm/600 ohms (Handset HS-2001)
- 1.2.7 Line in 0 dBm/600 ohms

1.3 RECEIVER

- 1.3.1 Receiving System Double-conversion superheterodyne
- 1.3.2 Frequency Range 100 kHz 29,999.9 kHz (10 Hz steps)
- 1.3.3 Sensitivity Input level at 10 ohms+250 pF (below 4 MHz) and 50 ohms
(above 4MHz) to produce SINAD 20 dB

Frequency Range	J3E/H3E
100 kHz to 300 kHz	35 dB μ V
300 kHz to 1.6 MHz	25 dB μ V
1.6 MHz to 4.0 MHz	13 dB μ V
4.0 MHz to 30 MHz	7 dB μ V

1.4 Intermediate Frequency	1st: 72,455 kHz, 2nd: 455 kHz
1.5 Selectivity	J3E: 2.4kHz at -6dB, H3E: 6kHz at -6dB J2B (F1B): 300Hz at -6dB
1.6 Inter-modulation	Better than 80 dB μ V
1.7 Spurious Response	Better than 70 dB
1.8 AGC	SLOW/FAST/OFF
1.9 BFO Frequency	Telex/DSC: 1,700 Hz, Facsimile: 1,900 Hz
1.10 Audio Output Power	Internal speaker: 1W/ 8 ohms External speaker: 4W/ 4 ohms Handset: 2.5mW/ 150 ohms Line output: 0 dBm/ 600 ohms
1.11 Standard Features	Noise Blanker, Voice-activated squelch, Pre-selector

2 DSC/WATCH KEEPING RECEIVER

2.1 DIGITAL SELECTIVE CALLING

2.1.1 Frequency Shift	Space: 1785.0 \pm 0.5 Hz, Mark: 1615.0 \pm 0.5 Hz
2.1.2 Baud Rate	100 bps \pm 30 x 10 ⁻⁶
2.1.3 Protocol	Complies with ITU-R Rec.493-10, 541-8, 1082-1
2.1.4 Modulation	AFSK
2.1.5 Distress Alarm	3.5 s to 4.5 s self-repetition
2.1.6 Distress Alarm Memory	50 messages

2.2 DSC/WATCH RECEIVER

2.2.1 Frequency Range	
MF/HF specification	2187.5/ 8414.5 and 4207.5/ 6312/12577/16804.5 kHz
MF specification	2187.5 kHz
2.2.2 Class of Emission	F1B, J2B
2.2.3 Antenna Impedance	50 ohms
2.2.4 Local Oscillator	1st: F+54,455 kHz, 2nd: 54,000 kHz, 3rd: 456.7 kHz
2.2.5 Frequency Stability	\pm 10 Hz
2.2.6 Intermediate Frequency	1st: 54,455 kHz, 2nd: 455 kHz
2.2.7 Selectivity	-6 dB: 270 Hz to 300 Hz, -30 dB: within \pm 380 Hz, -60 dB: within \pm 550 Hz
2.2.8 Receiving System	Double-conversion superheterodyne
2.2.9 Radiation	within 2 mW
2.2.10 RX Error Rate	1 % or less at 1 μ V input voltage

2.2.11	Spurious Response	31.6 mV non-modulated at 10 μ V input voltage, at error rate within 1%
2.2.12	Scanning Reception	max. 6 frequencies within 2 s (MF/HF)
2.2.13	Diagnosis	Transmit high frequency signal of DSC

2.3 GENERAL WATCH KEEPING RECEIVER (FS-2570 ONLY, OPTION)

2.3.1	Frequency Range	1,606.5 kHz to 27.5 MHz
2.3.2	Class of Emission	J2B, F1B
2.3.3	Antenna Impedance	50 ohms
2.3.4	Local Oscillator	1st: F+54,455 kHz, 2nd: 54,000 kHz, 3rd: 456.7 kHz
2.3.5	Frequency Stability	within \pm 10 Hz
2.3.6	Intermediate Frequency	1st: 54,455 kHz, 2nd: 455 kHz
2.3.7	Selectivity	-6 dB: 270 Hz to 300 Hz, -30 dB: within \pm 380 Hz, -60 dB: within \pm 550 Hz
2.3.8	Receiving System	Double-conversion superheterodyne
2.3.9	Radiation	within 2 mW
2.3.10	RX Error Rate	1 % or less at 1 μ V input voltage
2.3.11	Spurious Response	31.6 mV non-modulated at 10 μ V input voltage, at error rate within 1%
2.3.12	Scanning Reception	max. 6 frequencies within 2 s (MF/HF)
2.3.13	Diagnosis	Transmit high frequency signal of DSC

3 NBDP FUNCTION (OPTION)

3.1 GENERAL

3.1.1	Communication Mode	ARQ, FEC, DIRC (FSK)
3.1.2	Protocol	ITU-R M625-3, M476-5, M490, M491-1, M492-6
	ID code	4, 5, 9 column
	Line cord	4B/3Y (Intl.)
	Modulation	AFSK
	Tone frequency	1615/1785Hz \pm 0.5 Hz (mark/space)
	Tracking range	\pm 80 Hz
3.1.3	Applications	
	Auto-reception	Setting timer and frequency (max. 10 settings available)
	Frequency scanning	10 group max., 20 station as each group
	User-channels	100 channels max.

4 TERMINAL UNIT (IB-583)

4.1	Display	10.4-inch color TFT 640 x 480 dots
4.2	CPU	HD6417615 (15.5 MHz)
4.3	Memory	Flash ROM: 1 MB, S-RAM: 256 KB
4.4	FD Drive	720 KB/1.44MB 3.5"
4.5	Keyboard	82 keys, IBM PS/2
4.6	Other functions	Text editor, FD control, Printer, NAV-data reception/display, Remote control for Transceiver, Diagnosis

5 ANTENNA COUPLER

5.1	Tuning System	CPU controlled fully automatic tuning system
5.2	Frequency Range	1.6 MHz to 27.5Hz
5.3	Input Impedance	50 ohms
5.4	Antenna	7m to 30m wire or whip antenna
5.5	Power Capability	150 W (FS-1570), 250 W (FS-2570)
5.6	VSWR	1.5 max
5.7	Tuning Speed	Within 15 s
5.8	Dummy Load	FS-1570: 10 ohms + 250 pF/200W mounted in coupler FS-2570: 10 ohms + 250 pF/100W mounted in coupler

6 INTERFACE

6.1	Input data sentences	IEC 61162-1 (NMEA 0183-3)
	Ship's Position (L/L)	GGA>RMC>GLL
	Time	ZDA

7 POWER SUPPLY

7.1	Transceiver Unit/Control Unit	
	FS-1570	24 VDC: 0.8 A, max. 20 A (TX)
	FS-2570	24 VDC: 1.5 A, max. 35 A (TX)
7.2	AC/DC Power Supply Unit (option)	100/110/115/220/230VAC, 1 phase, 50/60 Hz

8 ENVIRONMENTAL CONDITION

8.1	Ambient Temperature	-15°C to +55°C
8.2	Relative Humidity	93 or less at 40°C
8.3	Water proofing (IEC 60529)	Control Unit (Panel): IPX2 Transceiver Unit: IPX0 Antenna Coupler: IPX5
8.4	Vibration	IEC 60945

9 COATING COLOR

9.1	Control Unit	Chassis: 2.5GY5/1.5, Panel: N3.0
9.2	Transceiver Unit	2.5GY5/1.5
9.3	Antenna Coupler	N9.5 (white)

Reference Only

試験成績書

Factory acceptance test sheet

SSB 送受信機

SSB Radio telephone

型式： FS-1570

Model

機番 Serial No.	3535-0453
製造年月日 Date of manufacture	2002 年 1 月 日 year month day
試験年月日 Date of measurement	2002 年 2 月 10 日 year month day
注番 Order sheet No.	

古野電気株式会社
FURUNO ELECTRIC CO., LTD.

承認 Approved by	担当 Measured by
	横山 N.YOKO

1. 2182kHz 送信及び受信部試験成績
Tx & Rx test on MF band

定格出力 RF Power (W)	周波数 FREQ. (kHz)	電波 型式 Mode	MIC 入力 MIC input	電源 Power supply		終段(PA) Final stage collector		入力 Input (W)	能率 Effi- ciency (%)	空中線出力 Antenna RF output		J/4 入力 Mic gain (-dB)	受信 感度 Rx sensi- tivity (dB)
			TONE	VOLT (V)	CURR (A)	VOLT (V)	CURR (A)			CURR (A)	POWER (W)		
50	2182	J3E	1 TONE	24	11.0	23.7	8.9	210	23.7	2.2	50		
			2 TONE										
75	2182	J3E	1 TONE	24	13.2	23.6	11.2	264	28.4	2.7	75		
	2 TONE												
	2187.5	J2B (FIB)		24	13.2	23.6	11.2	264	28.4	2.7	75		
100	2182	J3E	1 TONE	24	15.2	23.5	13.2	310	32.2	3.1	100	54	1.0
	2 TONE												
	2187.5	J2B (FIB)		24	15.2	23.5	13.2	310	32.2	3.1	100		-11
200	2182	J3E	1 TONE										
	2 TONE												
	2187.5	J2B (FIB)											
2182 (電力低下) Power reduction		J3E	1 TONE	24	8.0	23.9	5.9	141	17.8	1.6	25		

1. 送受信、各周波数帯に於ける最低周波数（代表周波数）で測定。
Measured on the lowest frequency in each band.

2. 終段トランジスタ（ 2SD1407 ）
Final stage transistor

3. 疑似負荷
Dummy load antenna
1.6MHz ~ 3.9MHz : 10Ω + 250 pF
4MHz ~ 25.1MHz : 50Ω

4. 設備規則及び型式検定規則の試験方法による。
Test method complies with Japanese Radio Regulation

5. 1 TONE Frequency : 1500Hz 2 TONE Frequency : 700HZ/1700Hz

2. 各周波数に於ける送信及び受信部試験成績

Tx & Rx test on HF band

周波数 FREQ. (MHz)	電波 型式 Mode	MIC入力 MIC input	電源 Power supply		終段(PA) Final stage collector		入力 Input (W)	能率 Effic- iency (%)	空中線 Antenna RF output		J/4 入力 MIC gain (-dB)	受信 感度 Rx sensi- tivity (dB)
		TONE	VOLT (V)	CURR (A)	VOLT (V)	CURR (A)			CURR (A)	POWER (W)		
4	J3E	1 TONE	24	18.0	23.4	16.6	388	38.6	1.8	150	56	0
		2 TONE										
	J2B (FIB)		24	18.0	23.4	16.6	388	38.6	1.8	150		
6	J3E	1 TONE	24	15.0	23.4	13.7	320	45.2	1.8	145	56	1.5
		2 TONE										
	J2B (FIB)		24	15.0	23.4	13.7	320	45.2	1.8	145		
8	J3E	1 TONE	24	15.5	23.4	15.7	367	39.4	1.9	145	57	0
		2 TONE										
	J2B (FIB)		24	15.5	23.4	15.7	367	39.4	1.9	145		
12	J3E	1 TONE	24	16.5	23.5	17.8	418	34.6	2.2	145	54	0
		2 TONE										
	J2B (FIB)		24	16.5	23.5	17.8	418	34.6	2.2	145		
16	J3E	1 TONE	24	16.5	23.5	17.2	404	34.6	2.2	140	56	0
		2 TONE										
	J2B (FIB)		24	16.5	23.5	17.2	404	34.6	2.2	140		
18	J3E	1 TONE	24	16.5	23.5	17.1	402	34.8	2.2	140	55	- 1.0
		2 TONE										
	J2B (FIB)		24	16.5	23.5	17.1	402	34.8	2.2	140		
22	J3E	1 TONE	24	18.4	23.3	19.3	450	32.2	3.1	145	55	0
		2 TONE										
	J2B (FIB)		24	18.4	23.3	19.3	450	32.2	3.1	145		
25	J3E	1 TONE	24	21.5	23.0	20.0	460	23.9	3.0	110	55	0
		2 TONE										
	J2B (FIB)		24	21.5	23.0	20.0	460	23.9	3.0	110		
4 (電力低下) Power reduction	J3E	1 TONE	24	14.5	23.5	11.7	275	29.0	1.3	80		

3. 送信部性能試験 Transmitter		
項目 Check Item	判定基準 Ratings	結果 Results
3.1)周波数偏差 Frequency Stability	± 10 Hz 以内(within)	GOOD
3.2)総合歪み及び雑音(比) Overall Distortion and Noise	20 dB 以上(more than)	GOOD
3.3)総合周波数特性 Modulation AF Response	350～2700 Hz : - 6 dB 以内(within)	GOOD
3.4)不要電波の減衰量(J3E) Suppression of Unwanted Emission	± 1.5～4.5 kHz : - 31 dB 以下(less than) ± 4.5～7.5 kHz : - 38 dB 以下(less than) ± 7.5 kHz 以上 : - 43 dB 以下(less than)	GOOD
3.5)搬送波減衰量 Carrier Suppression	- 40dB 以下(less than)	GOOD
3.6)下側波帯強度 (減衰比) LSB Attenuation	- 40dB 以下(less than)	GOOD
3.7)スプリアス強度 (減衰比) Spurious Emission	- 43dB 以下(less than)	GOOD
3.8)占有周波数帯幅 Band width	J3E : 3kHz 以下(less than) J2B(F1B) : 500Hz 以下(less than)	GOOD
備考) 設備規則及び型式検定規則の試験方法による試験結果である。 Test method complies with Japanese Radio Regulation.		

4. 受信部性能試験 Receiver		
項目 Check Item	判定基準 Ratings	結果 Results
4.1)総合歪み及び雑音(比) Overall Distortion and Noise	20 dB 以下(less than)	GOOD
4.2) 減衰量及び通過帯域幅 Selectivity	- 6 dB reduction ・ J3E : 2.4 kHz～3.0 kHz ・ J2B(F1B) : 270 Hz～300 Hz	GOOD
4.3) 受信感度 Sensitivity	J3E SINAD 20 dB ・ 6～4 MHz +15 dB μ 以下(less than) ・ 4～27.5 MHz +8 dB μ 以下(less than) J2B(F1B) SER 1%以下(lass than) ・ 6～4 MHz +8 dB μ 以下(less than) ・ 4～27.5 MHz +0 dB μ 以下(less than)	GOOD
4.4)スプリアスレスポンス Spurious Response	90 dB 以上(more than)	GOOD
備考) 設備規則及び型式検定規則の試験方法による試験結果である。 Test method complies with Japanese Radio Regulation.		

Reference Only

項目 Check Item	結果 Results
5.1) 通話試験 Voice Communication test	GOOD
5.2) DSC 動作試験 DSC function and Communication test	GOOD
5.3) NBDP 動作試験 NBDP function and Communication test	GOOD
5.4) DISTRESS 試験 DSC distress alert function and Communication test	GOOD

Reference Only

試験成績書

Factory acceptance test sheet

SSB 送受信機

SSB Radio telephone

型式： FS-2570

Model

機番 Serial No.	3536-0228
製造年月日 Date of manufacture	2003 年 1 月 日 year month day
試験年月日 Date of measurement	2003 年 2 月 10 日 year month day
注番 Order sheet No.	

古野電気株式会社
FURUNO ELECTRIC CO., LTD.

承認 Approved by	担当 Measured by
	横山 N.YOKO

1. 2182kHz 送信及び受信部試験成績 Tx & Rx test on MF band

定格出力 RF Power (W)	周波数 FREQ. (kHz)	電波 型式 Mode	MIC 入力 MIC input	電源 Power supply		終段(PA) Final stage collector		入力 Input (W)	能率 Effi- ciency (%)	空中線出力 Antenna RF output		J/4 入力 Mic gain (-dB)	受信 感度 Rx sensi- tivity (dB)
			TONE	VOLT (V)	CURR (A)	VOLT (V)	CURR (A)			CURR (A)	POWER (W)		
50	2182	J3E	1 TONE	24	13.5	23.5	10.7	251	19.8	2.2	50		
			2 TONE										
75	2182	J3E	1 TONE	24	16.0	23.4	13.7	320	23.4	2.6	75		
			2 TONE										
	2187.5	J2B (FIB)		24	16.0	23.4	13.7	320	23.4	2.6	75		
100	2182	J3E	1 TONE	24	22.5	23.2	17.2	399	25.0	3.0	100	56	1.5
			2 TONE										
	2187.5	J2B (FIB)		24	22.5	23.2	17.2	399	25.0	3.0	100		-10
200	2182	J3E	1 TONE	24	33.0	23.0	28.0	644	31.1	4.3	200		
			2 TONE										
	2187.5	J2B (FIB)		24	33.0	23.0	28.0	644	31.1	4.3	200		
2182 (電力低下) Power reduction		J3E	1 TONE	24	16.0	23.4	13.7	320	23.4	2.6	75		

- 送受信、各周波数帯に於ける最低周波数（代表周波数）で測定。
Measured on the lowest frequency in each band.
- 終段トランジスタ（ 2SD1407 ）
Final stage transistor
- 疑似負荷
Dummy load antenna
1.6MHz ~ 3.9MHz : 10Ω + 250 pF
4MHz ~ 25.1MHz : 50Ω
- 設備規則及び型式検定規則の試験方法による。
Test method complies with Japanese Radio Regulation
- 1 TONE Frequency : 1500Hz 2 TONE Frequency : 700Hz/1700Hz

2. 各周波数に於ける送信及び受信部試験成績
 Tx & Rx test on HF band

周波数 FREQ. (MHz)	電波 型式 Mode	MIC 入力 MIC input	電源 Power supply		終段(PA) Final stage collector		入力 Input (W)	能率 Efficiency (%)	空中線 Antenna RF output		J/4 入力 MIC gain (-dB)	受信 感度 Rx sensitivity (dB)
		TONE	VOLT (V)	CURR (A)	VOLT (V)	CURR (A)			CURR (A)	POWER (W)		
4	J3E	1 TONE	24	35.0	22.9	30.0	687	34.9	2.1	240	54.8	0
		2 TONE										
	J2B (FIB)		24	35.0	22.9	30.0	687	34.9	2.1	240		
6	J3E	1 TONE	24	33.5	22.9	27.5	630	38.1	2.1	240	55.5	-1.0
		2 TONE										
	J2B (FIB)		24	33.5	22.9	27.5	630	38.1	2.1	240		
8	J3E	1 TONE	24	35.0	22.9	30.0	687	34.9	2.2	240	55.0	1.0
		2 TONE										
	J2B (FIB)		24	35.0	22.9	30.0	687	34.9	2.2	240		
12	J3E	1 TONE	24	33.5	23.4	27.6	646	37.1	2.8	240	54.0	1.0
		2 TONE										
	J2B (FIB)		24	33.5	23.4	27.6	646	37.1	2.8	240		
16	J3E	1 TONE	24	35.0	23.4	30.0	702	34.2	3.0	240	55.0	1.0
		2 TONE										
	J2B (FIB)		24	35.0	23.4	30.0	702	34.2	3.0	240		
18	J3E	1 TONE	24	35.0	23.4	30.0	702	34.2	3.4	240	54.0	0.5
		2 TONE										
	J2B (FIB)		24	35.0	23.4	30.0	702	34.2	3.4	240		
22	J3E	1 TONE	24	35.0	23.4	30.0	702	33.5	3.8	235	55.5	2.0
		2 TONE										
	J2B (FIB)		24	35.0	23.4	30.0	702	33.5	3.8	235		
25	J3E	1 TONE	24	35.0	23.3	30.0	699	31.5	3.8	220	56.0	1.5
		2 TONE										
	J2B (FIB)		24	35.0	23.3	30.0	699	31.5	3.8	220		
4 (電力低下) Power reduction	J3E	1 TONE	24	21.5	23.4	15.9	372	21.5	1.3	80		

3. 送信部性能試験 Transmitter		
項目 Check Item	判定基準 Ratings	結果 Results
3.1)周波数偏差 Frequency Stability	± 10 Hz 以内(within)	GOOD
3.2)総合歪み及び雑音(比) Overall Distortion and Noise	20 dB 以上(more than)	GOOD
3.3)総合周波数特性 Modulation AF Response	350～2700 Hz : -6 dB 以内(within)	GOOD
3.4)不要電波の減衰量(J3E) Suppression of Unwanted Emission	± 1.5～4.5 kHz : -31 dB 以下(less than) ± 4.5～7.5 kHz : -38 dB 以下(less than) ± 7.5 kHz 以上 : -43 dB 以下(less than)	GOOD
3.5)搬送波減衰量 Carrier Suppression	-40dB 以下(less than)	GOOD
3.6)下側波帯強度 (減衰比) LSB Attenuation	-40dB 以下(less than)	GOOD
3.7)スプリアス強度 (減衰比) Spurious Emission	-43dB 以下(less than)	GOOD
3.8)占有周波数帯幅 Band width	J3E : 3kHz 以下(less than) J2B(F1B) : 500Hz 以下(less than)	GOOD
備考) 設備規則及び型式検定規則の試験方法による試験結果である。 Test method complies with Japanese Radio Regulation.		

4. 受信部性能試験 Receiver		
項目 Check Item	判定基準 Ratings	結果 Results
4.1)総合歪み及び雑音(比) Overall Distortion and Noise	20 dB 以下(less than)	GOOD
4.2) 減衰量及び通過帯域幅 Selectivity	-6 dB reduction ・ J3E : 2.4 kHz～3.0 kHz ・ J2B(F1B) : 270 Hz～300 Hz	GOOD
4.3) 受信感度 Sensitivity	J3E SINAD 20 dB ・ 6～4 MHz +15 dB μ 以下(less than) ・ 4～27.5 MHz +8 dB μ 以下(less than) J2B(F1B) SER 1%以下(lass than) ・ 6～4 MHz +8 dB μ 以下(less than) ・ 4～27.5 MHz +0 dB μ 以下(less than)	GOOD
4.4)スプリアスレスポンス Spurious Response	90 dB 以上(more than)	GOOD
備考) 設備規則及び型式検定規則の試験方法による試験結果である。 Test method complies with Japanese Radio Regulation.		

Reference Only

項目 Check Item	結果 Results
5.1) 通話試験 Voice Communication test	GOOD
5.2) DSC 動作試験 DSC function and Communication test	GOOD
5.3) NBDP 動作試験 NBDP function and Communication test	GOOD
5.4) DISTRESS 試験 DSC distress alert function and Communication test	GOOD

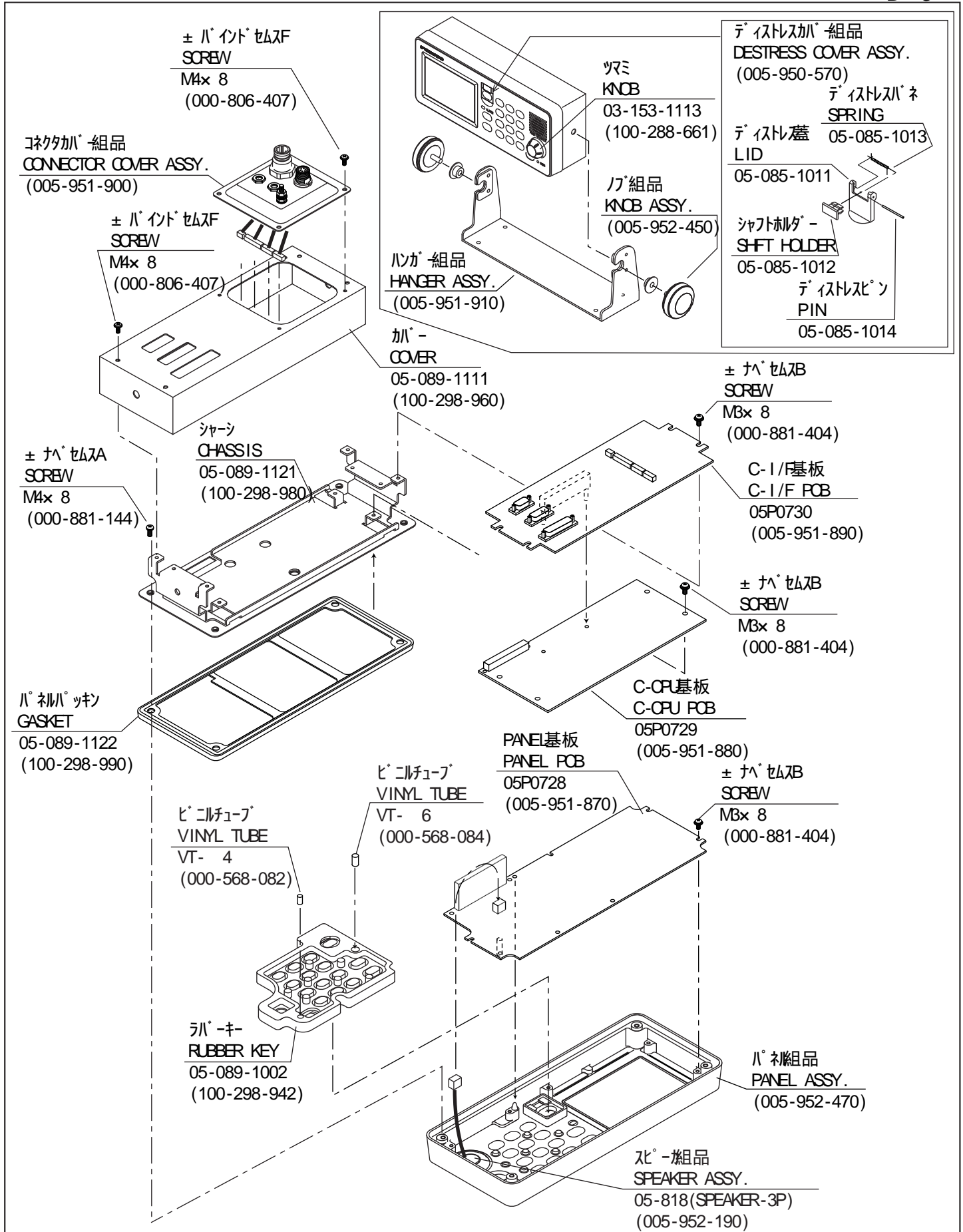

APPROVED 承認 2002.11.11	
CHECKED 審査 2002.11.11	
DRAWN 製図 2002.11.11	

TITLE
FS-2570C 操作部 CONTROL UNIT

DWG. NO. C5636-E03-A

FS-1570/2570

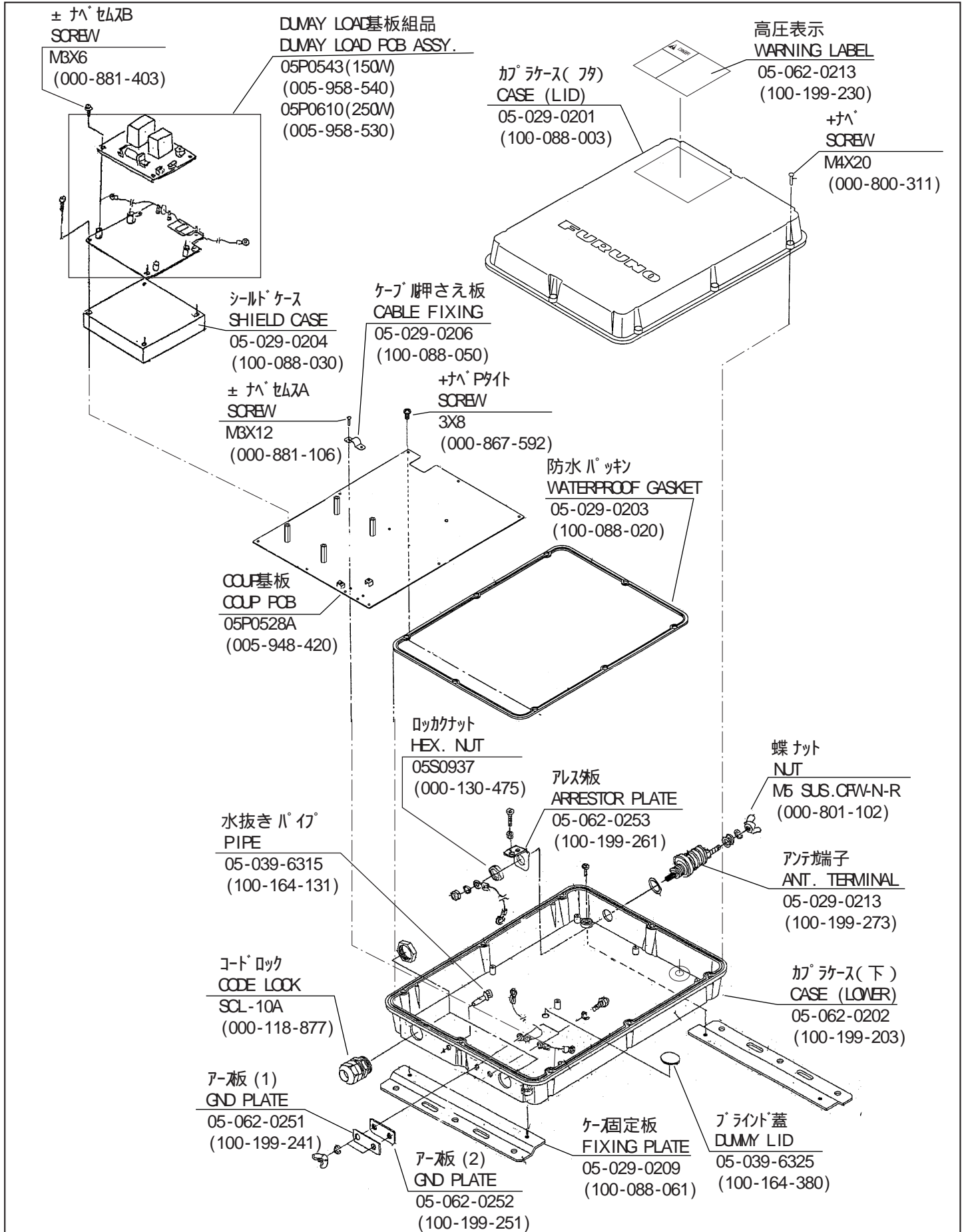

FS-1562
FS-15/75/2550
FS-1570/2570

APPROVED 承認 2002.11.8		TITLE	アンテナカプラー
CHECKED 審査 2002.11.8		AT-1560-AAS	ANTENNA COUPLER
DRAWN 製図 2002.11.8		DWG. NO.	C5636-E04-A

ハンドセット
HANDSET
HS-2001

+H` P`タ付
SCREW
2.6x 20
(000-808-976)

+H` P`タ付
SCREW
2.6x 15
(000-808-977)

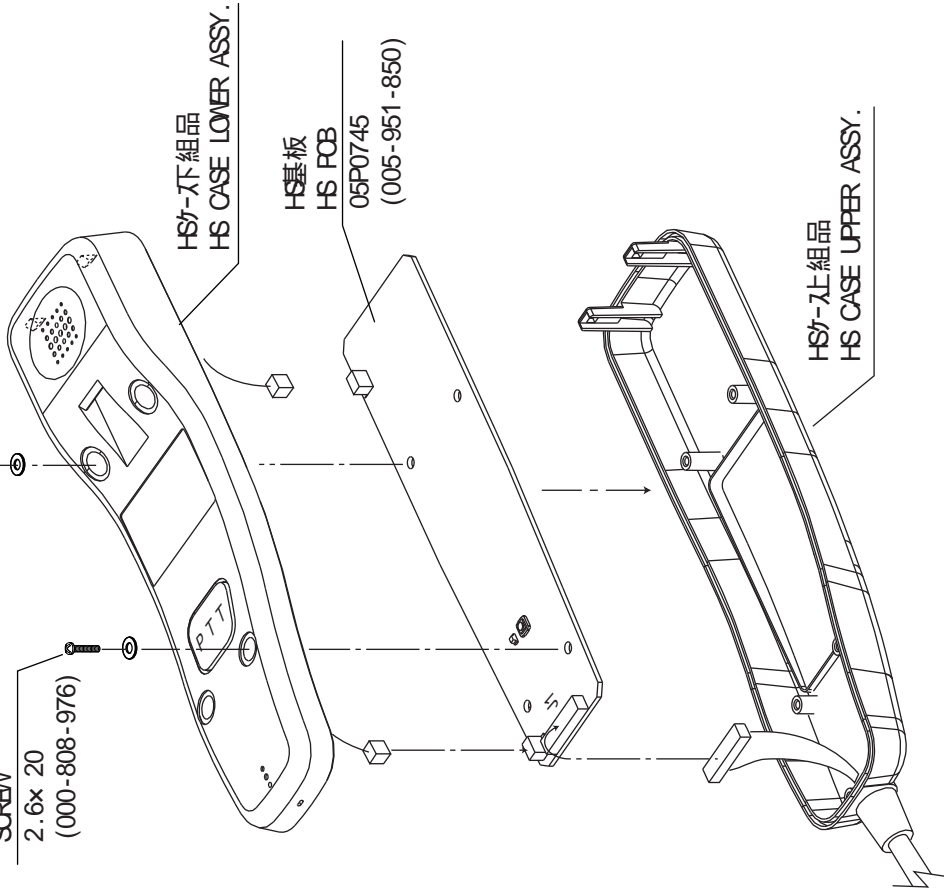

ハンドセットハンガー
HANDSET HANGER
FP05-05510
(005-951-790)

+H` P`タ付
SCREW
M3x 20
(000-809-016)

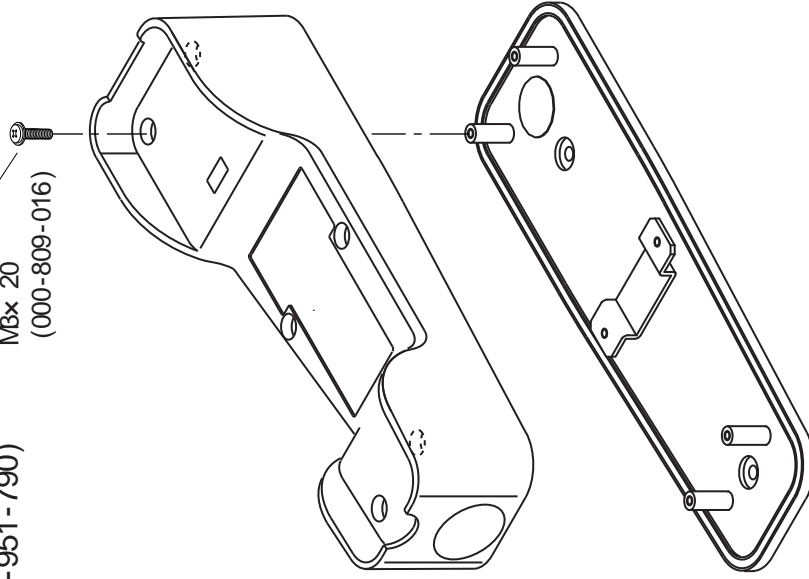

APPROVED
承認
2002.11.11

CHECKED
審査
2002.11.11

DRAWN
製図
2002.11.11

利
高橋
三好

TITLE
ハンドセットハンガー -
HANDSET/HANDSET HANGER

HS-2001

DWG. NO. C5636-E05-A

FS-1570/2570

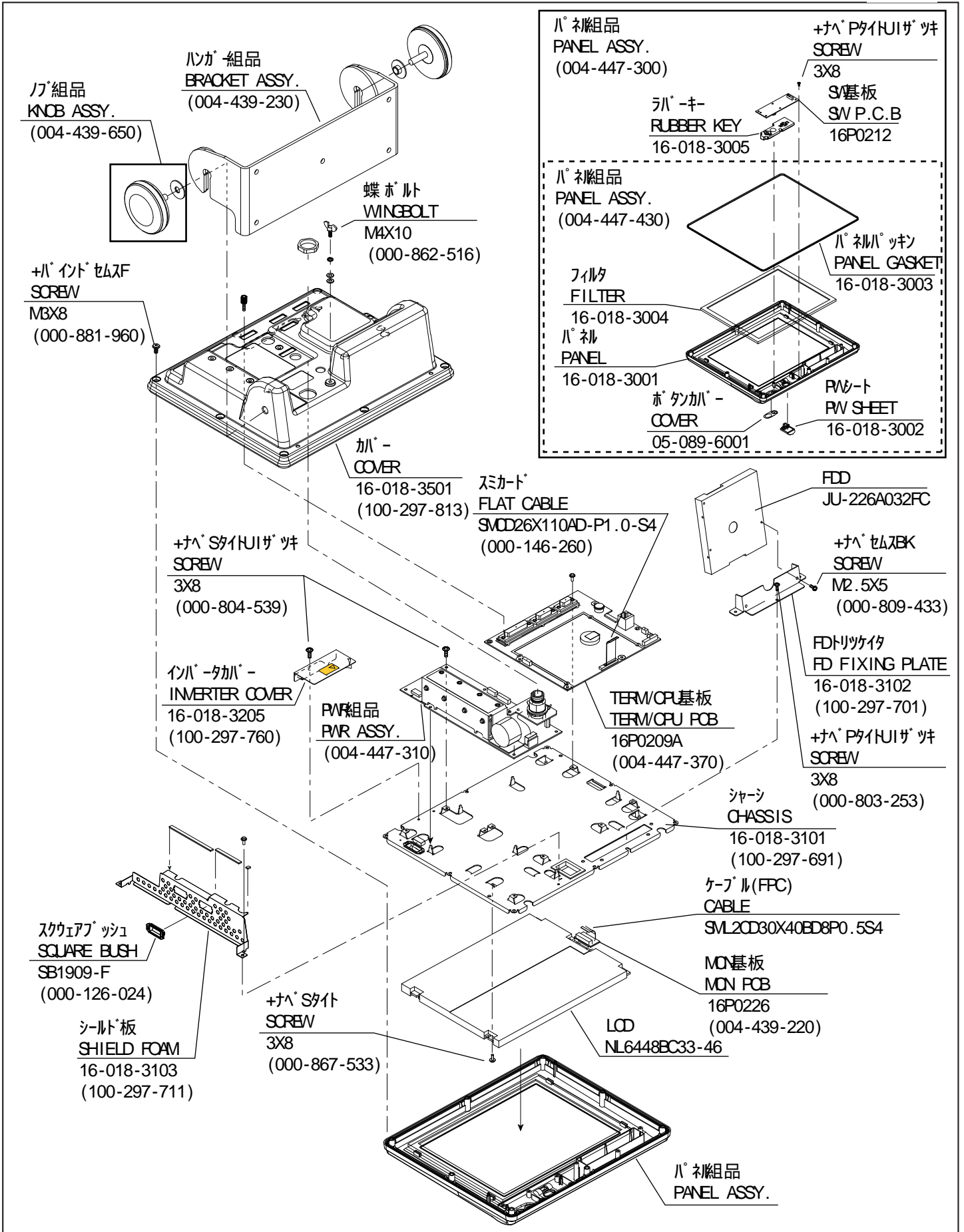

APPROVED 承認 2002.11.8		TITLE	ターミナルユニット
CHECKED 審査 2002.11.8		IB-583	TERMINAL UNIT
DRAWN 製図 2002.11.8		DWG. NO.	C5636-E06-A

FS-1570/2570

FURUNO

電気部品表

ELECTRICAL PARTS LIST

2002年 11月

Model	FS-1570T	
Unit	送受信部 TRANSCEIVER UNIT	
Ref.Dwg.	C5636-K01-B, C5636-K02-A	Page
Blk.No.		E-1

SYMBOL	TYPE	CODE No.	REMARKS	SHIPPABLE ASSEMBLY
回路記号	型式	コード番号	備考	出荷単位組品
PRINTED CIRCUIT BOARD		プリント基板		
B2	05P0731, T-IF	005-952-000		✓
B3	05P0732, T-CPU	005-952-010		✓
B4	05P0733, TX-RX	005-952-030		✓
B5	05P0734, W/R	005-952-060		✓
B6	05P0735, PA	005-952-140		✓
B7	05P0736, TX-FIL	005-952-100		✓
B8	05P0737, SW-REG	005-952-110		✓
B9	05P0742, MB	005-951-980		✓
B10	05P0746, PRESEL	005-952-040		✓
B11	05P0747, REF OSC	005-952-050		✓
B13, 14	05P0751, DSP	005-952-020		✓
	05P0751A, DSP	005-953-010	from Feb, 2003	✓
B17	05P0744, RELAY	005-952-070		✓
	05P0466 (HIC), NB/DET	005-938-860	TX/RX	✓
ASSEMBLY		組品		
	PA Transistor Set	005-952-370	SD1407 X 2	✓
FAN ASSEMBLY		ファン組品		
B1, B2	05-816 (FAN-R2P)	005-952-210	BL-SM Connector	✓
CONNECTOR		コネクタ		
J3	M-R-A3-3 (N)	000-115-105	W/R1 ANT	
J5	M-PA-JJ (M)	000-146-111	T/R ANT	
THERMAL GUARD		サーマルガード		
S1	OHD3-45M	000-144-292		
CABLE w/CONNECTOR		コネクタ付ケーブル		
W1	L-420	000-146-062	07S0047	
W3	L-90	000-146-066	07S0046	
W4	L-450	000-522-006	07S0046	
W5, W6	L-500	000-146-064	07S0046	
W7	PH04D-520	000-146-074	05S0752	
W8	VH05D-850	000-146-068	05S0051	
W9	VH03D-500	000-146-070	05S0751	
W10	PH10D-550	000-146-071	05S0752	
W13	05S9346	000-146-592		
W15	L-160	000-522-075	07S0046	
W17	PH08D-220	000-146-078	05S0752	
	05-817 (P6-P2, P2P)	005-952-220	PH-SM Connector	

FURUNO

電気部品表

ELECTRICAL PARTS LIST

2002年 11月

Model	FS-2570T	
Unit	送受信部 TRANSCEIVER UNIT	
Ref.Dwg.	C5637-K01-C, C5637-K02-B	Page
Blk.No.		E-2

SYMBOL	TYPE	CODE No.	REMARKS	SHIPPABLE ASSEMBLY
回路記号	型式	コード番号	備考	出荷単位組品
PRINTED CIRCUIT BOARD		プリント基板		
B2	05P0731, T-IF	005-952-000		✓
B3	05P0732, T-CPU	005-952-010		✓
B4	05P0733, TX-RX	005-952-030		✓
B5, B18	05P0734, W/R	005-952-060		✓
B6, B17	05P0739, PA	005-952-130		✓
B7	05P0736, TX-FIL	005-952-100		✓
B8	05P0737, SW-REG	005-952-110		✓
B9	05P0743, MB	005-951-990		✓
B10	05P0746, PRESEL	005-952-040		✓
B11	05P0747, REF OSC	005-952-050		✓
B12	05P0744, RELAY	005-952-070		✓
B13, 14	05P0751, DSP	005-952-020		✓
	05P0751A, DSP	005-953-010	from Feb, 2003	✓
B15	05P0738, DRV	005-952-120		✓
B16	05P0740, COMB	005-952-150		✓
	05P0466 (HIC), NB/DET	005-938-860	TX/RX	✓
ASSEMBLY		組品		
	PA Transistor Set	005-952-370	SD1407 X 2	✓
	DRV Transistor Set	005-952-390	SD1405 X 2	✓
	Terminator R	005-952-410	COMB	✓
FAN ASSEMBLY		ファン組品		
	05-816 (FAN-R2P)	005-952-210	BL-SM Connector	✓
CONNECTOR		コネクタ		
J3, J4	M-R-A3-3 (N)	000-115-105	W/R1, W/R2 ANT	
J5	M-PA-JJ (M)	000-146-111	T/R ANT	
CABLE w/CONNECTOR		コネクタ付ケーブル		
W1	L-420	000-146-062	07S0047	
W4	L-450	000-522-006	07S0046	
W5	L-550	000-146-065	07S0046	
W9	VH03D-600	000-146-069	05S0751	
W10	PF10D-550	000-146-071	05S0752 (from Feb, 2003)	
W12, W15	L-200	000-522-003	07S0046	
W13, W20	L-170	000-522-076	07S0046	
W14, W19	PH08D-330	000-146-077	05S0752	
W17	PH06D-600	000-146-075	05S0752	
W21	PH03D-350	000-124-077	05S0752	
	05-817 (P6-P2, P2P)	005-952-220	PH-SM Connector	

FURUNO

電気部品表

ELECTRICAL PARTS LIST

2002年 11月

Model	FS-2570C	
Unit	操作部 CONTROL UNIT	
Ref.Dwg.	C5636-K03-A	Page
Blk.No.		E-3

SYMBOL	TYPE	CODE No.	REMARKS	SHIPPABLE ASSEMBLY
回路記号	型式	コード番号	備考	出荷単位組品
PRINTED CIRCUIT BOARD		プリント基板		
B2	05P0728, PANEL	005-951-870		✓
B3	05P0729, C-CPU	005-951-880		✓
B4	05P0730, C-IF	005-951-890		✓
PANEL ASSEMBLY		パネル組品		
	FS-2570C	005-952-470		✓
SPEAKER ASSEMBLY		スピーカ組品		
LS1	05-818 (SPEAKER-3P)	005-952-190	SP-PH Connector	✓

FURUNO

電気部品表

ELECTRICAL PARTS LIST

2002年 11月

Model	AT-1560	
Unit	アンテナカプラー ANTENNA COUPLER	
Ref.Dwg.	C5572-K03-B	Page
Blk.No.		E-4

SYMBOL	TYPE	CODE No.	REMARKS	SHIPPABLE ASSEMBLY
回路記号	型式	コード番号	備考	出荷単位組品
PRINTED CIRCUIT BOARD		プリント基板		
B1	05P0528A, COUP	005-948-420		✓
ASSEMBLY		組品		
B3	05P0543, DUMMY LOAD	005-958-540	AT-1560-15, 150W	✓
	05P0610, DUMMY LOAD	005-958-530	AT-1560-25, 250W	✓

FURUNO

電気部品表

ELECTRICAL PARTS LIST

2002年 11月

Model	HS-2001	
Unit	ハンドセット HANDSET	
Ref.Dwg.	C5636-K05-A	Page
Blk.No.		E-5

SYMBOL	TYPE	CODE No.	REMARKS	SHIPPABLE ASSEMBLY
回路記号	型式	コード番号	備考	出荷単位組品
	PRINTED CIRCUIT BOARD	プリント基板		
B2	05P0745, HS	005-951-850		✓

FURUNO

電気部品表

ELECTRICAL PARTS LIST

2002年 11月

Model	IB-583	
Unit	ターミナルユニット TERMANIL UNIT	
Ref.Dwg.	C5636-K06-A	Page
Blk.No.		E-6

SYMBOL	TYPE	CODE No.	REMARKS	SHIPPABLE ASSEMBLY
回路記号	型式	コード番号	備考	出荷単位組品
PRINTED CIRCUIT BOARD		プリント基板		
2B3	16P0209A, TERM/CPU	004-447-370		✓
2B5	16P0212, SW	004-439-100		✓
2B6	16P0226, MCN	004-439-220		✓
2B10	16P0214, PWR-C	004-439-170		✓
2B11	16P0223, PWR HIC	004-439-150		✓
2B12	16P0221, PWR HIC	004-439-130		✓
2B13	16P0224, PWR HIC	004-439-160		✓
2B15	16P0220, PWR HIC	004-439-140		✓
PANEL ASSEMBLY		パネル組品		
	IB-583	004-447-300	with 16P0212	✓
	IB-583	004-447-430	without 16P0212	✓
POWER ASSEMBLY		電源組品		
2B4	IB-583	004-447-310	16P0211A/0214, PWR PCB	✓
MINI KEYBOARD		ミニキーボード		
	BTC-5100C PS/2	004-442-400		✓
PROGRAM FD		プログラムFD		
	FP16-00601	004-439-400		✓
LCD		LCD		
2B7	NL6448BC33-46	000-144-814		
FDD		FDD		
2B8	JU-226A032FC	000-146-045		
CABLE w/CONNECTOR		コネクタ付ケーブル		
W1	05-821 (8-5, 3P)	004-447-380	PH Connector	
W5	16-164 (7-7P)	004-439-310	PH Connector	
W12	SML2CD30X40BD8P0.5S4	000-146-187	FPC CABLE	
W13	SMCD26X110AD-P1.0-S4	000-146-260	FLAT CABLE	

Contents of Drawings

Name	Type	Dwg. No.	Page	Remark
150W SSB Interconnection diagram	FS-1570	C5636-C01	S-1	FS-1570
250W SSB Interconnection diagram	FS-2570	C5637-C01	S-2	FS-2570
Transceiver unit				
FS-1570T schematic diagram	FS-1570T(1/2)	C5636-K01	S-3	FS-1570T
	FS-1570T(2/2)	C5636-K02	S-4	
FS-2570T schematic diagram	FS-2570T(1/2)	C5637-K01	S-5	FS-1570T
	FS-2570T(2/2)	C5637-K02	S-6	
T-IF	05P0731(1/2)	C5636-K08	S-7	FS-1570T/2570T
	05P0731(1/2)	C5636-K09	S-8	
RELAY	05P0744	C5636-K10	S-9	FS-1570T/2570T
TX/RX	05P0733(1/3)	C5636-K11	S-10	FS-1570T FS-2570T
	05P0733(2/3)	C5636-K12	S-11	
	05P0733(3/3)	C5636-K13	S-12	
PRESEL	05P0746	C5636-K14	S-13	FS-1570T/2570T
REF OSC	05P0747	C5636-K15	S-14	FS-1570T/2570T
FS-1570T PA	05P0735	C5636-K16	S-15	FS-1570T
FS-2570T DRV	05P0738	C5637-K03	S-16	FS-2570T
FS-2570T PA	05P0739	C5637-K04	S-17	FS-2570T
FS-2570T COMB	05P0740	C5637-K05	S-18	FS-2570T
TX FIL	05P0736	C5636-K17	S-19	FS-1570T/2570T
DSP	05P0751	C5636-K18	S-20	FS-1570T/2570T
T-CPU	05P0732(1/7)	C5636-K19	S-21	FS-1570T FS-2570T
	05P0732(2/7)	C5636-K20	S-22	
	05P0732(3/7)	C5636-K21	S-23	
	05P0732(4/7)	C5636-K22	S-24	
	05P0732(5/7)	C5636-K23	S-25	
	05P0732(6/7)	C5636-K24	S-26	
	05P0732(7/7)	C5636-K25	S-27	
SW REG	05P0737	C5636-K04	S-28	FS-1570T/2570T
W/R-1, W/R-2	05P0734(1/2)	C5636-K26	S-29	FS-1570T/2570T
	05P0734(2/2)	C5636-K27	S-30	

Name	Type	Dwg. No.	Page	Remark
FS-1570T M.B	05P0742	C5636-K28	S-31	FS-1570T
FS-2570T M.B	05P0743	C5637-K06	S-32	FS-2570T
Controller unit				
FS-2570C schematic diagram	FS-2570C	C5636-K03	S-33	FS-1570T/2570T
C-IF	05P0730	C5636-K29	S-34	FS-1570T/2570T
C-CPU	05P0729(1/3)	C5636-K30	S-35	FS-1570T/2570T
	05P0729(1/3)	C5636-K31	S-36	
	05P0729(1/3)	C5636-K32	S-37	
PANEL	05P0728	C5636-K33	S-38	FS-1570T/2570T
Handset unit				
HS(HS-2001)	05P0745	C5636-K05	S-39	FS-1570T/2570T
Antenna coupler unit				
AT-1560-15/25 schematic diagram	AT-1560-15/25	C5572-K03	S-40	FS-1570 FS-2570
COUP	05P0528	C5572-K01	S-41	AT-1560-15 (FS-1570)
	05P0528A			AT-1560-25 (FS-2570)
DUMMY LOAD	05P0543	C5572-K02	S-42	AT-1560-15 (FS-1570)
DUMMY LOAD	05P0610	C5572-K16	S-43	AT-1560-25 (FS-2570)

Name	Type	Dwg. No.	Page	Remark
NBDP terminal unit				
IB-581 schematic diagram	IB-581	C5609-K03	S-44	FS-1570T FS-2570T
IB-583 schematic diagram	IB-583	C5636-K06	S-45	
TERM CPU	16P0209A(1/3)	C5636-K34	S-46	
	16P0209A(2/3)	C5636-K35	S-47	
	16P0209A(3/3)	C5636-K36	S-48	
PWR	16P0211A	C5636-K07	S-49	
H IC	16P0220	C5636-K37	S-50	
	16P0221	C5636-K38	S-51	
	16P0223	C5636-K39	S-52	
	16P0224	C5636-K40	S-53	
SW	16P0212	C5635-K13	S-54	
Distress button/Incoming indicator unit				
IC-302-DSC	16P0150	C5613-K04	S-55	DISTRESS
IC-303-DSC				INCOMMING
AC/DC power supply unit				
AC/DC power supply unit	PR-300	C5572-K17	S-56	FS-1570
AC/DC power supply unit	PR-850A	C5519-K24	S-57	FS-2570
Power status monitor unit				
Power status monitor	PSM-01	C5636-K41	S-58	FS-1570T/2570T
Printer interface unit				
IF-8500 schematic diagram	IF-8500	C5603-K10	S-59	FS-1570T/2570T
IF-8500 CPU	05P0640	C5603-K11	S-60	FS-1570T/2570T
Pre AMP unit				
FAX-5	08P3122	C6246-005	S-61	FS-1570T/2570T

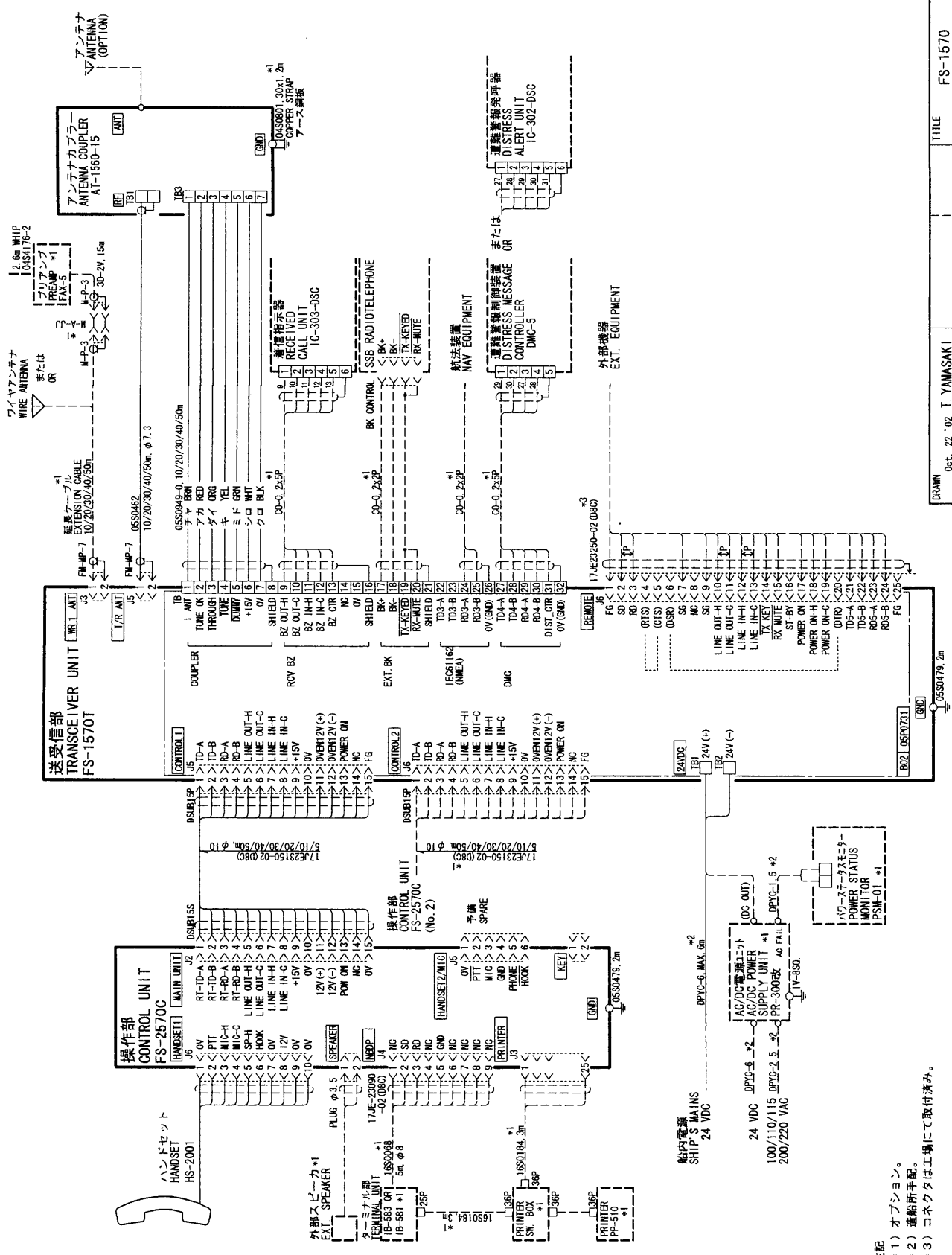

DRAWN	Oct. 22 '02	I. YAMASAKI	TITLE	FS-1570
CHECKED	Oct. 22 '02	Y. KINURA	名称	150W SSB 送受信機
APPROVED	Oct. 22 '02	Y. KINURA	相互結線図	
SCALE		MASS	NAME	SSB TRANSCEIVER
ENG. No.		C55636-C01-D		INTERCONNECTION DIAGRAM

- 注記
- *1) オプション。
 - *2) 造船所手配。
 - *3) コネクタは工場にて取付済み。

船内電源
SHIP'S MAINS
24 VDC

24 VDC 電源ユニット
AC/DC POWER
SUPPLY UNIT *1

100/110/115 DPYC-2.5 *2
200/220 VAC

DPYC-6 MAX. 6m *2

LOC. OUT

POWER STATUS
MONITOR
PSM-01 *1

00-0.2x2P: 00-SPEW-SB-C 0.2x2P. φ10.5
00-0.2x5P: 00-SPEW-SB-C 0.2x5P. φ13.5

NOTE

- *1. OPTION.
- *2. SHIPYARD SUPPLY.
- *3. CONNECTOR PLUGS FITTED AT FACTORY.

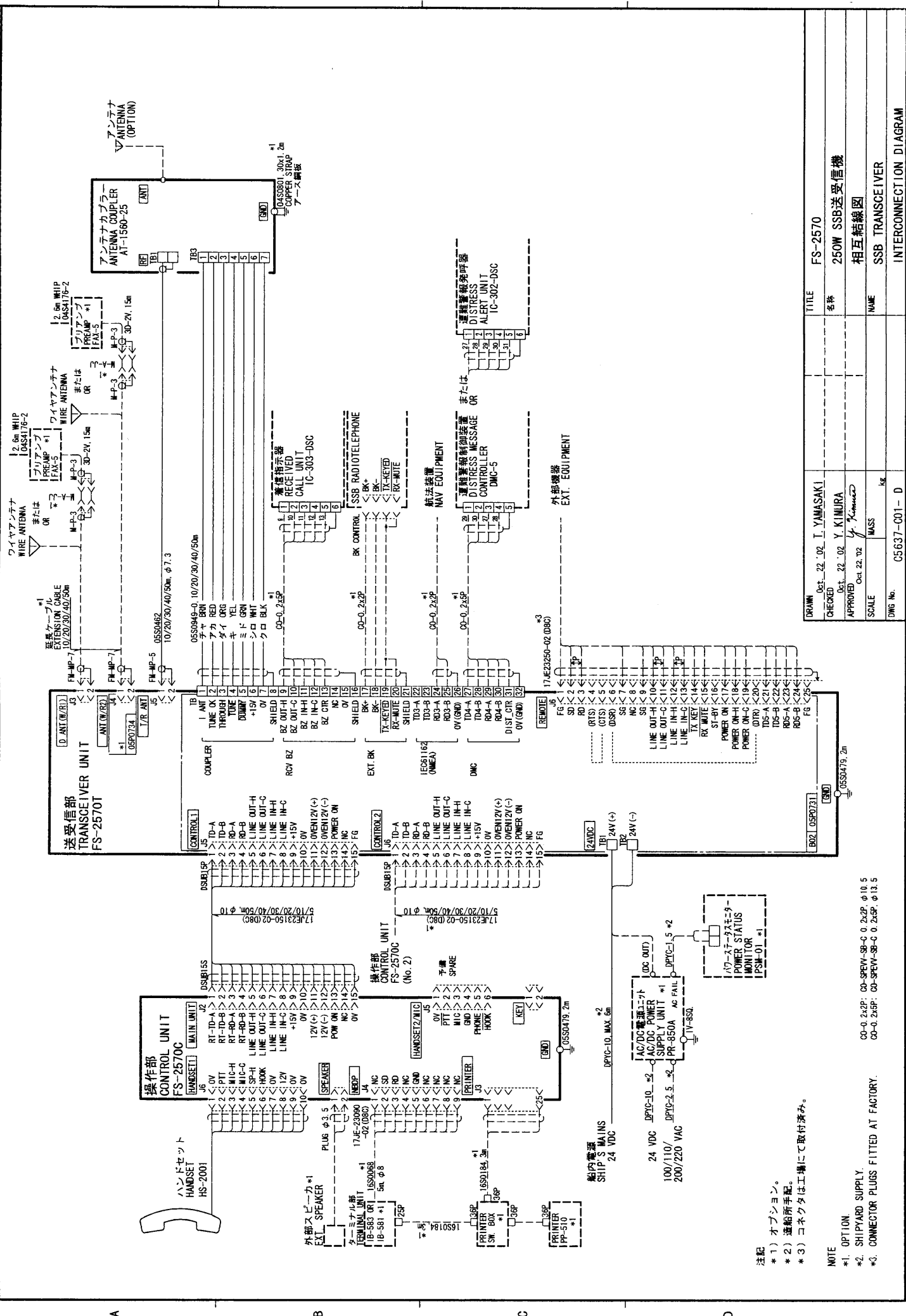

DRAWN	Oct. 22 '92	I. YAMASAKI	TITLE	FS-2570
CHECKED	Oct. 22 '92	Y. KIMURA	名称	250W SSB送受信機
APPROVED	Oct. 22 '92	Y. KIMURA	相互結線図	
SCALE		1/1	NAME	SSB TRANSCEIVER
DWG. No.		C5637-001-D		INTERCONNECTION DIAGRAM

注記
 *1) オプション。
 *2) 造船所手配。
 *3) コネクタは工場にて取付済み。

NOTE
 *1. OPTION
 *2. SHIPYARD SUPPLY.
 *3. CONNECTOR PLUGS FITTED AT FACTORY.

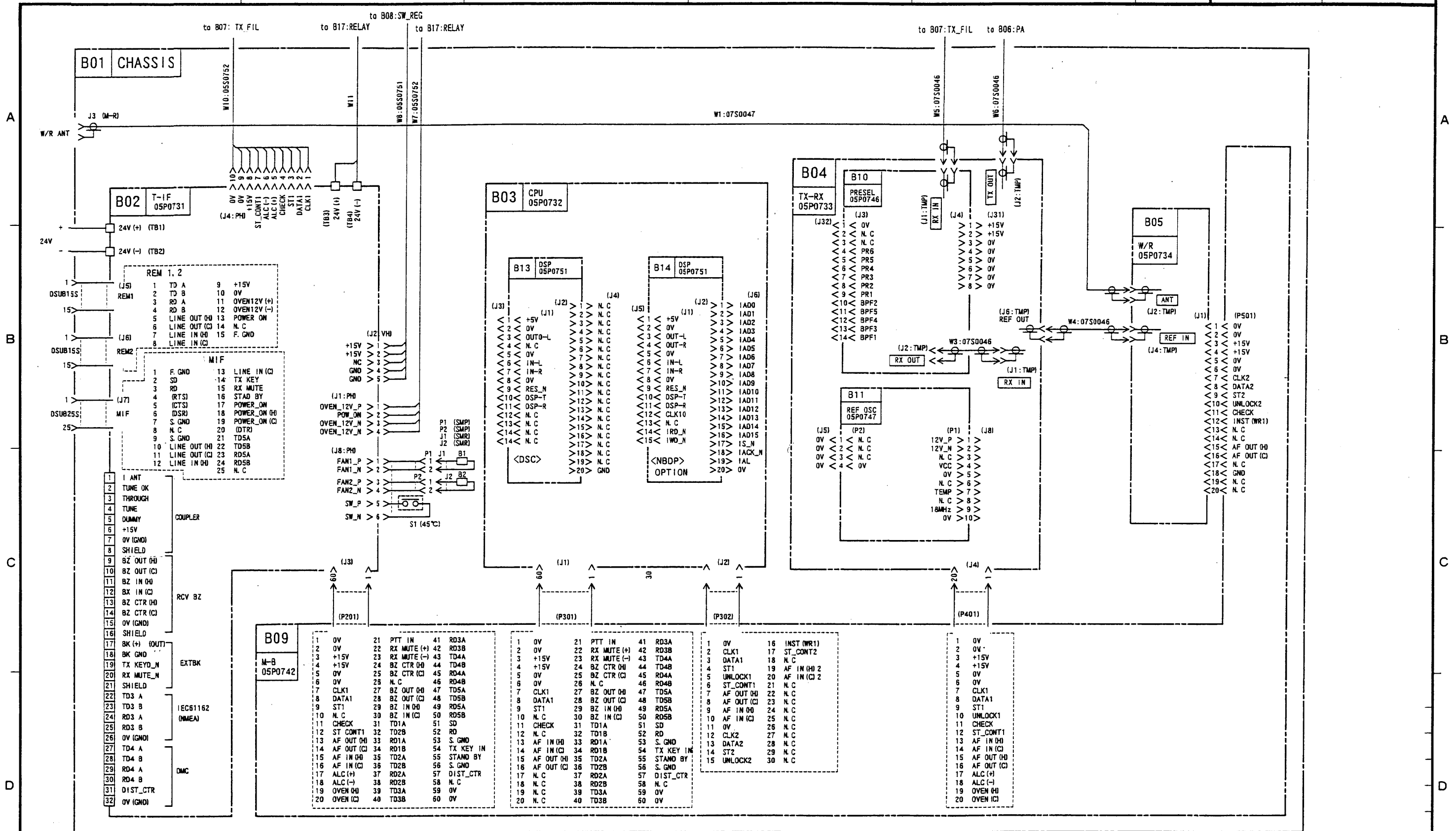

DRAWN 02/10/09 T. YAMASAKI	TYPE FS-1570T (1/2)
CHECKED 02/10/09 Y. Kikawa	名称 トランシーバユニット
APPROVED 02/10/09 Y. Kikawa	回路図
SCALE MASS	MODEL FS-1570
Dwg No. C5636-K01-B	BLOCK No. 05-001-3859-0
	NAME TRANSCIEVER UNIT
	SCHEMATIC DIAGRAM

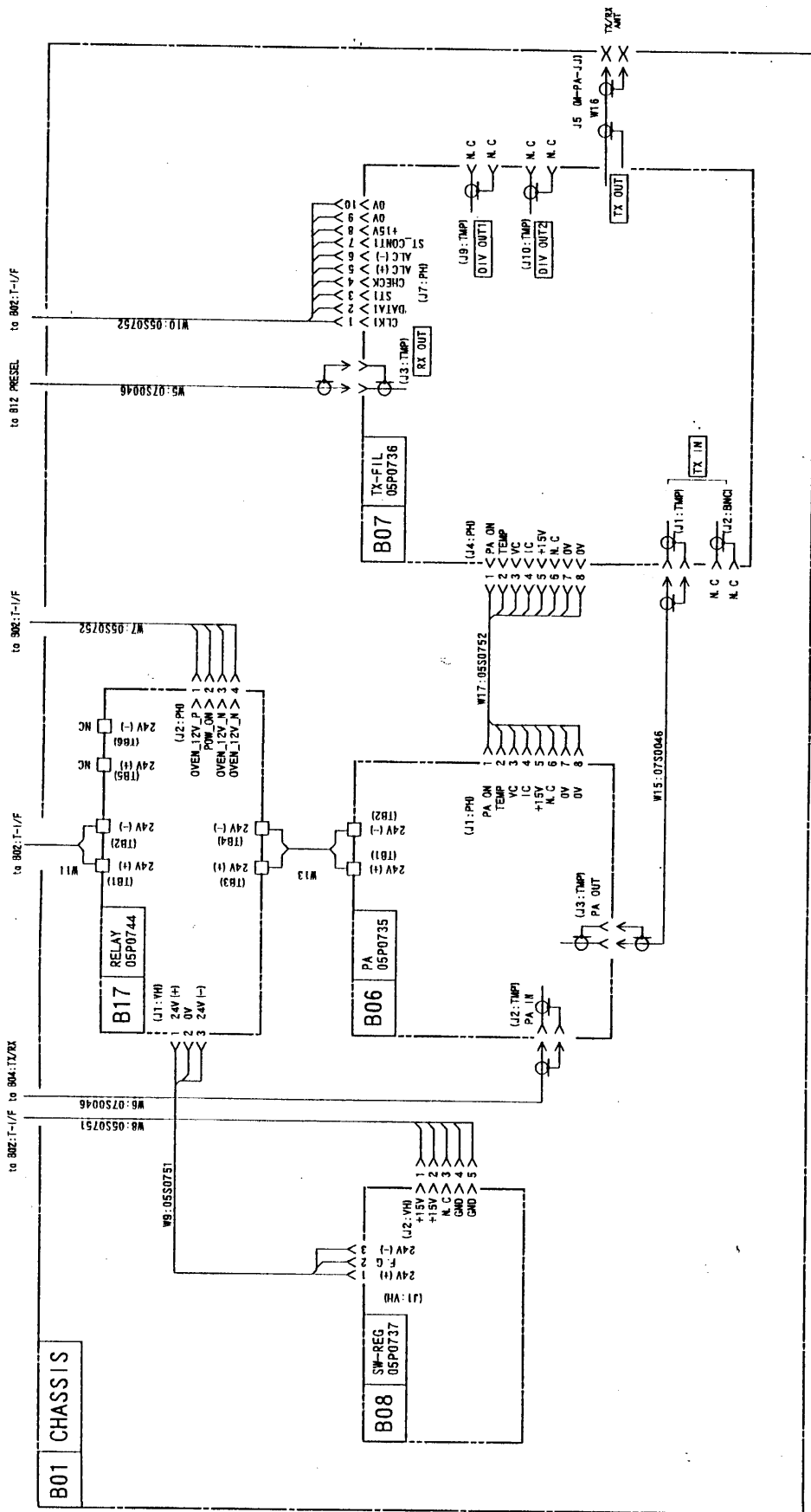

DRAWN	02/04/26	T. YAMASAKI	TYPE	FS-1570T (2/2)
CHECKED	02/04/26	Y.K.I.	名称	トランシーバユニット
APPROVED	02/04/26	Y.K.I.	回路図	
SCALE		MASS	MODEL	FS-1570
			BLOCK No.	
			NAME	TRANSCEIVER UNIT
Dwg No.	C5636-K02-A		05-001-3859-0	SCHEMATIC DIAGRAM

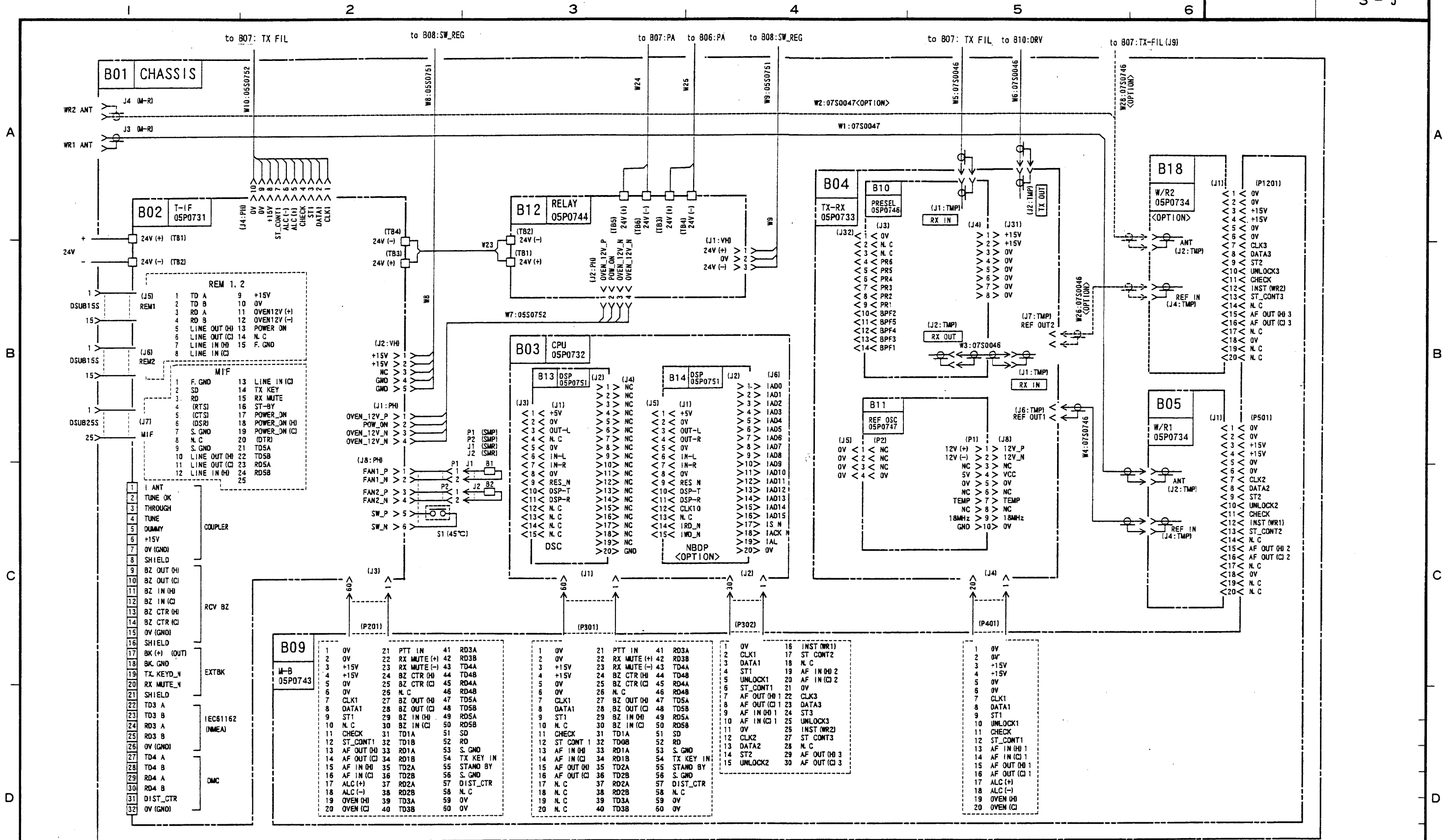

DRAWN 02/10/09 T. YAMASAKI	TYPE FS-2570T (1/2)
CHECKED 02/10/09 Y. Kima	名称 トランシーバユニット
APPROVED 02/10/09 Y. Kima	回路図
SCALE MASS	MODEL FS-2570
Dwg No. C5637-K01- C	BLOCK No. NAME TRANSCEIVER UNIT
05-001-3869-1	SCHMATIC DIAGRAM

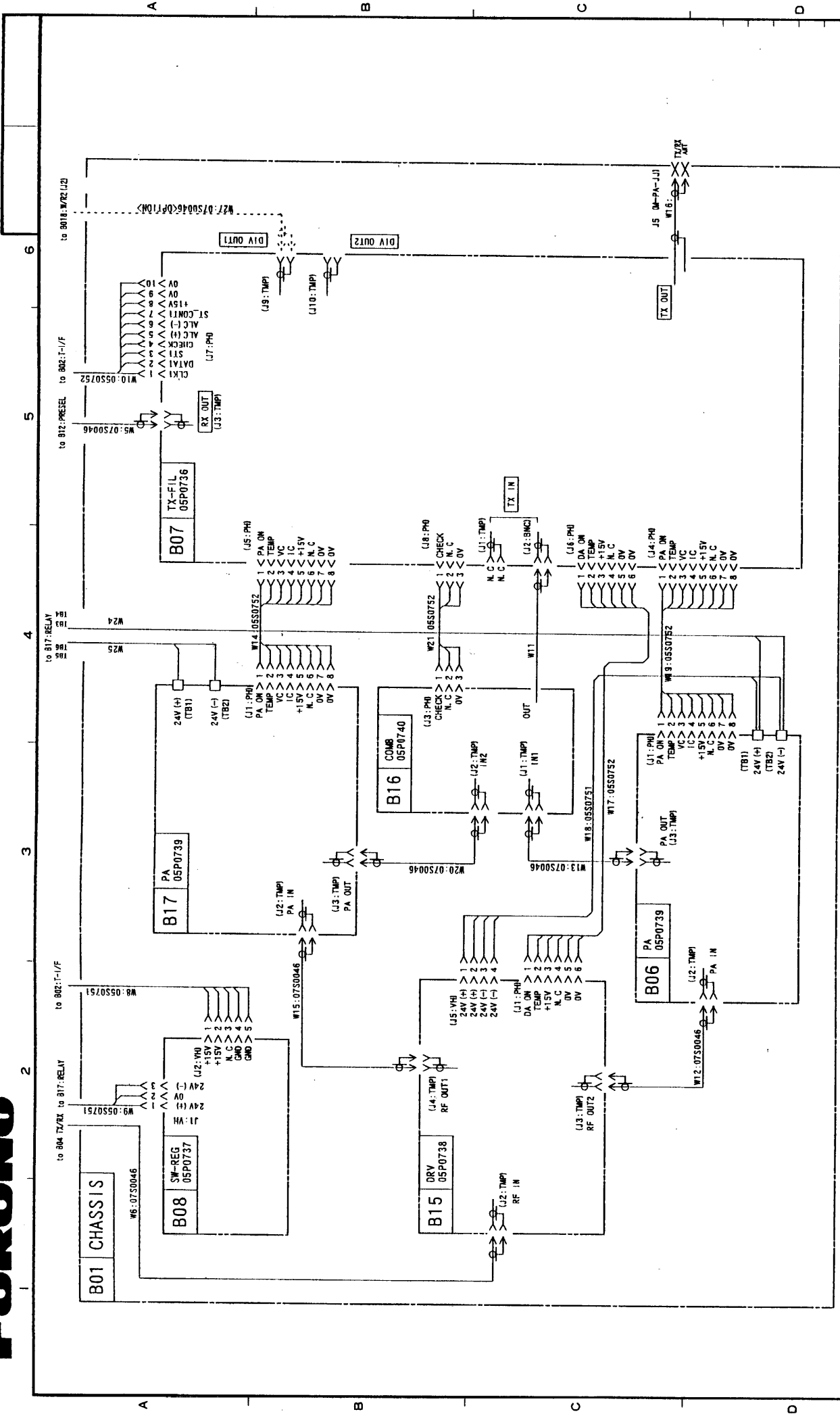

DRAWN	02/06/06	T. YAMASAKI	TYPE	FS-2570T (2/2)
CHECKED	02/07/07	Y. K.	名称	トランシーバーユニット
APPROVED	02/07/07	Y. K.	回路図	回路図
SCALE		MASS	MODEL	FS-2570
			BLOCK No.	
			NAME	TRANSCIEIVER UNIT
			Dwg No.	05-001-3869-0
				SCHEMATIC DIAGRAM

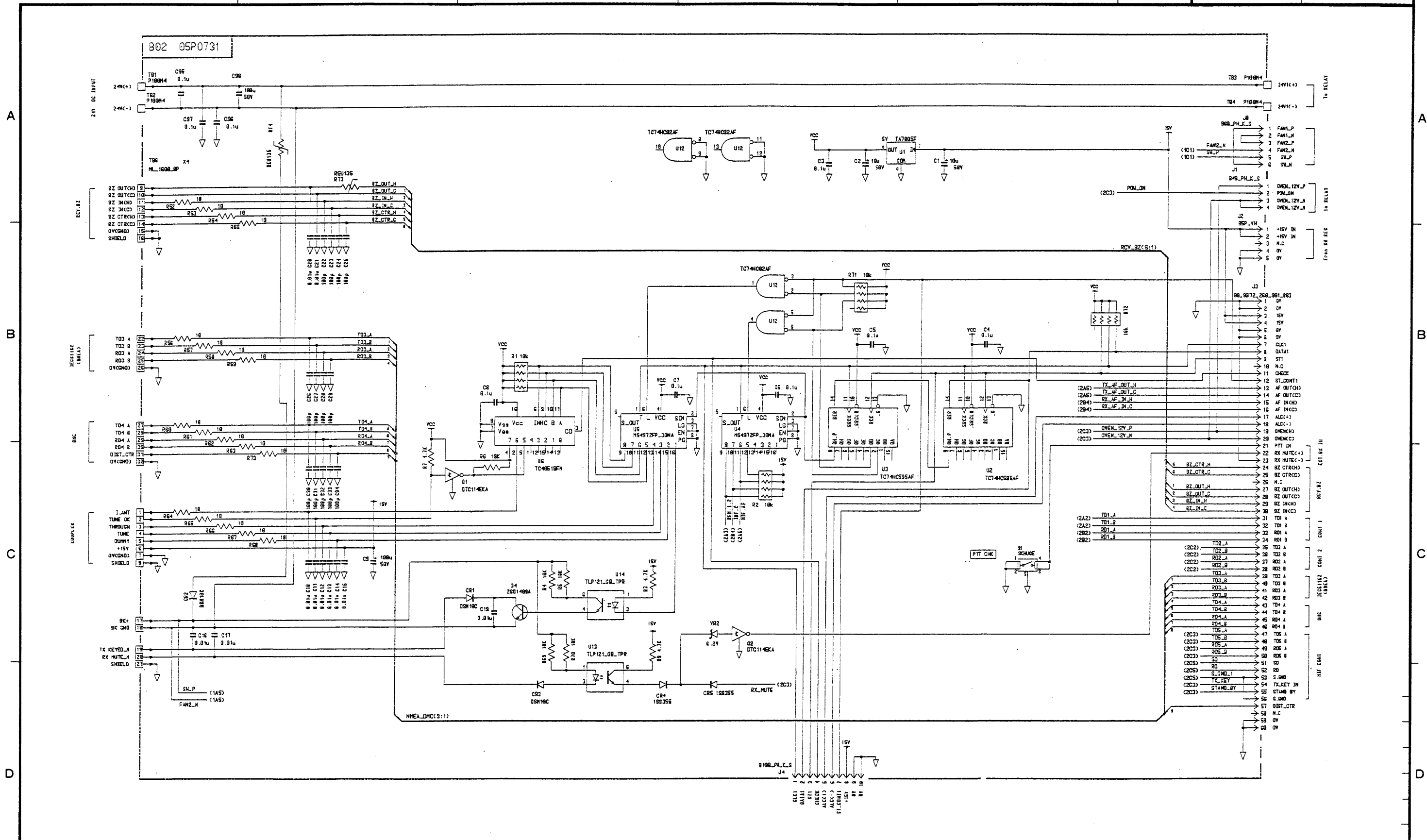

DRAWN	02/09/09 T. YAMASAKI	TYPE	05P0731 (1/2)
CHECKED	02/09/09 Y.K.	名称	T-IF基板
APPROVED	02/09/09 Y.K.	回路図	
SCALE	MASS	MODEL	FS-1570T/2570T 1B 2
		BLOCK No.	
Dwg No.	C5636-K08- A	NAME	T-IF PCB
			SCHMATIC DIAGRAM

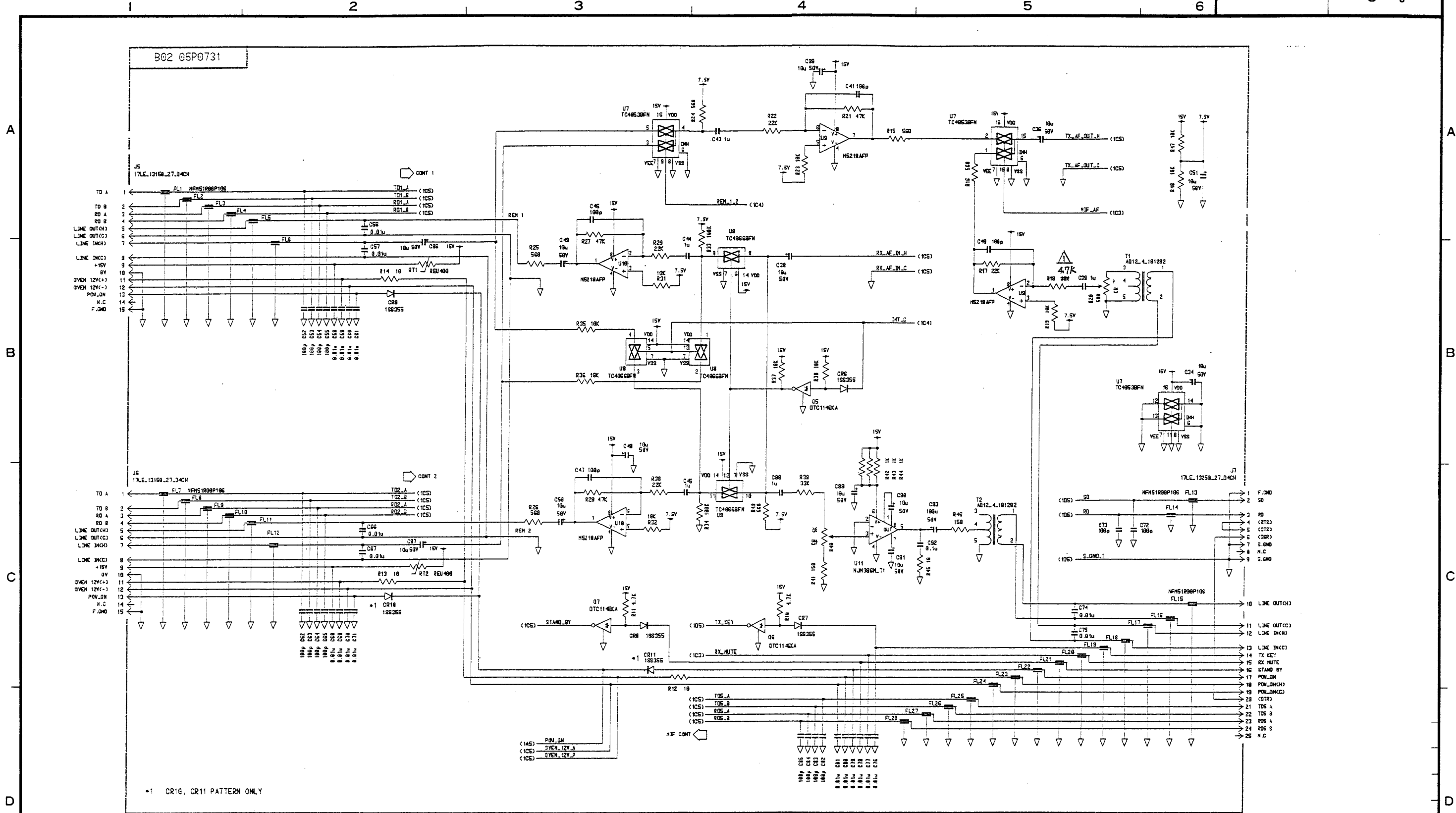

DRAWN 02/09/09 T. YAMASAKI	TYPE 05P0731 (2/2)
CHECKED 12/9/0 Y.K.	名称 T-IF基板
APPROVED 07/9/0 Y.K.	回路図
SCALE MASS	MODEL FS-1570T/2570T 1B 2
Dwg No. C5636-K09- A	BLOCK No. 05-001-3860-0
	NAME T-IF PCB
	SCHEMATIC DIAGRAM

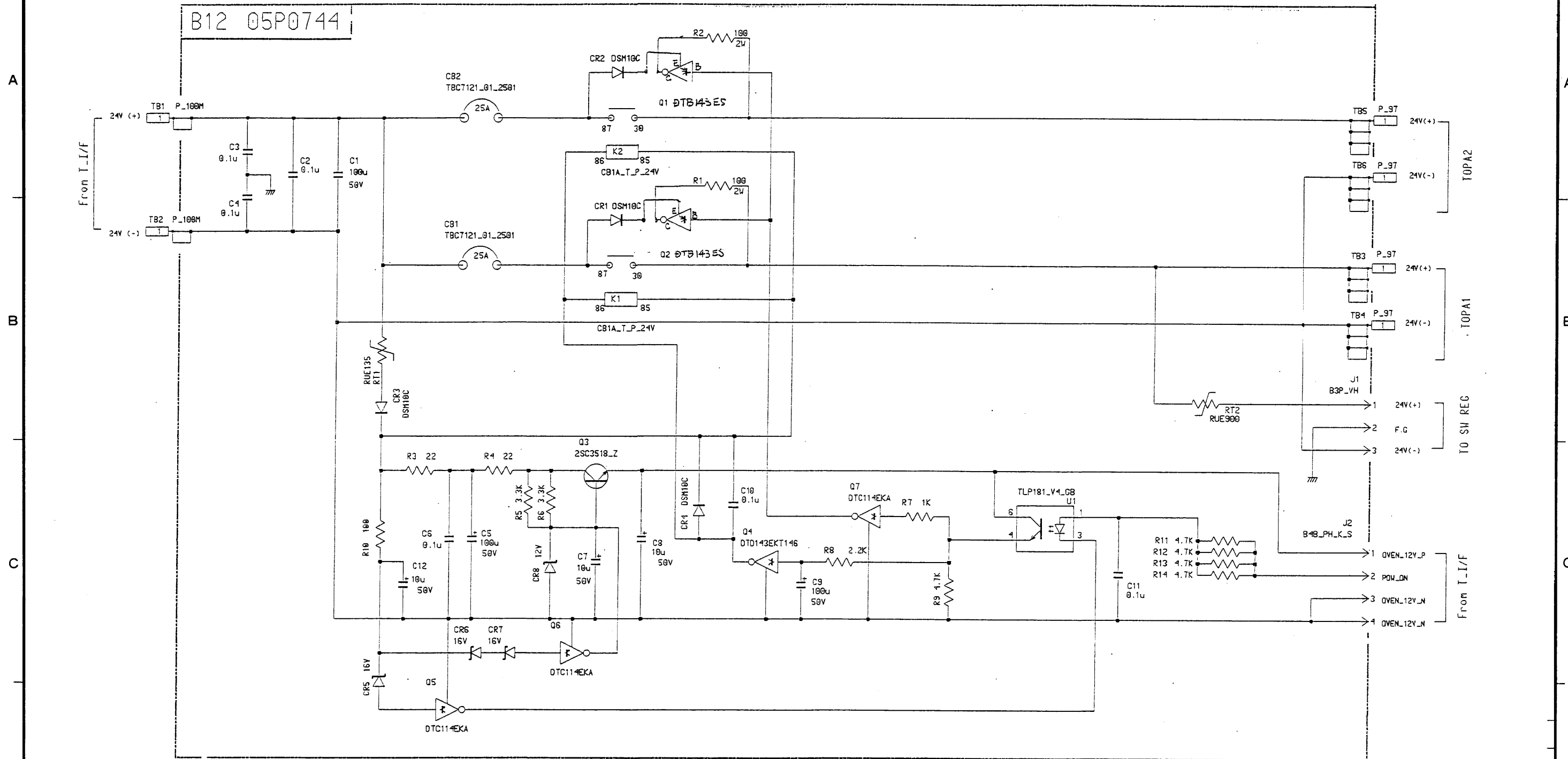

DRAWN 02/09/09 T. YAMASAKI	TYPE 05P0744
CHECKED 02/09/09 Y.K.	名称 RELAY基板
APPROVED 02/09/09 Y.K.	回路図
SCALE MASS	MODEL BLOCK No.
Dwg No. C5636-K10- A	NAME RELAY PCB
05-001-3870-1	SCHEMATIC DIAGRAM

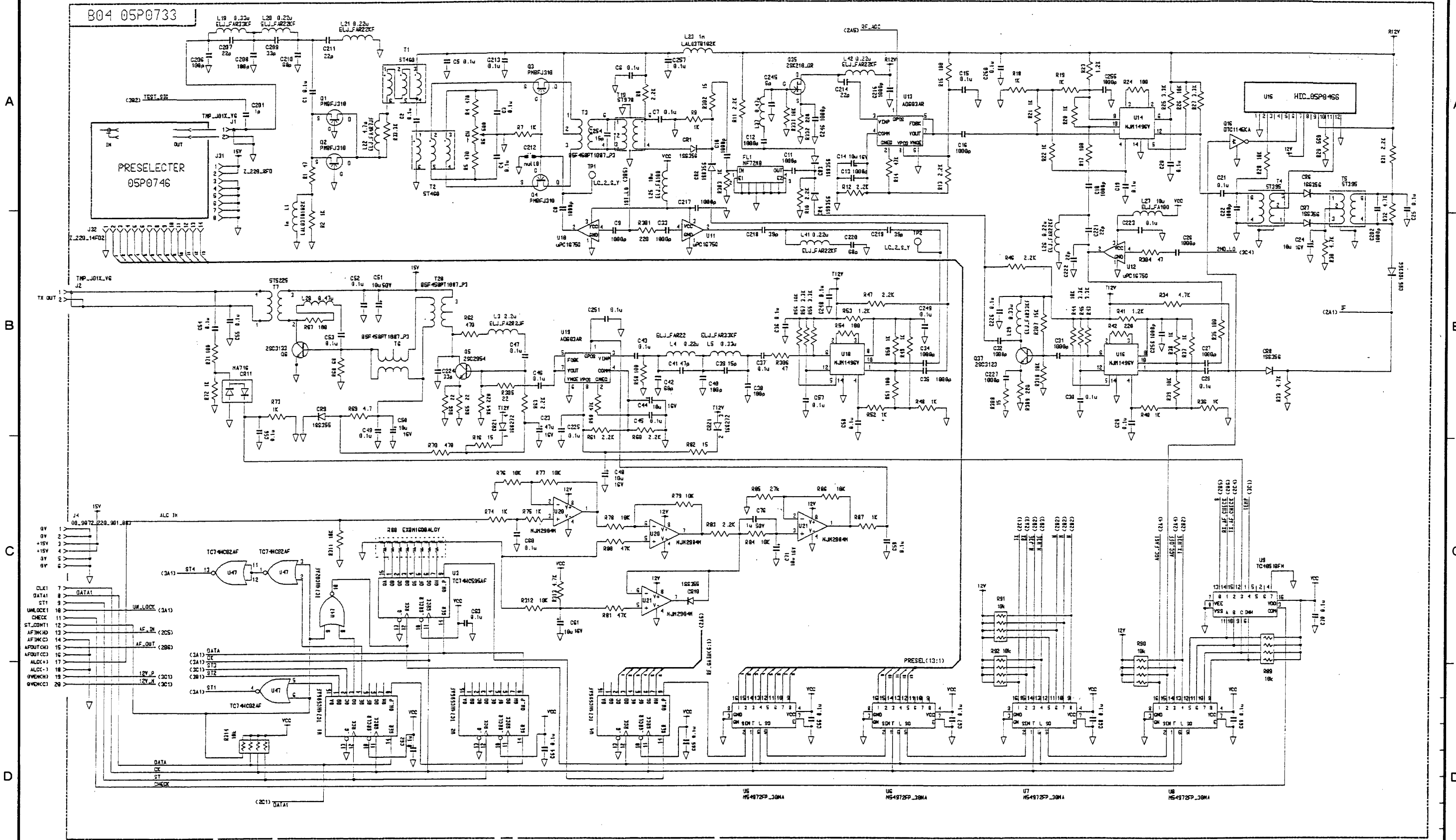

DRAW 02/09/09 T. YAMASAKI CHECKED 02/09/09 Y.K. APPROVED 02/09/09 Y.K. SCALE MASS Dwg No. C5636-K11-A	TYPE 05P0733 (1/3) 名称 TX/RX基板 回路図 NAME TX/RX PCB SCHEMATIC DIAGRAM
FS-1570T/2570T 1B 4 MODEL BLOCK No.	05-001-3862-0

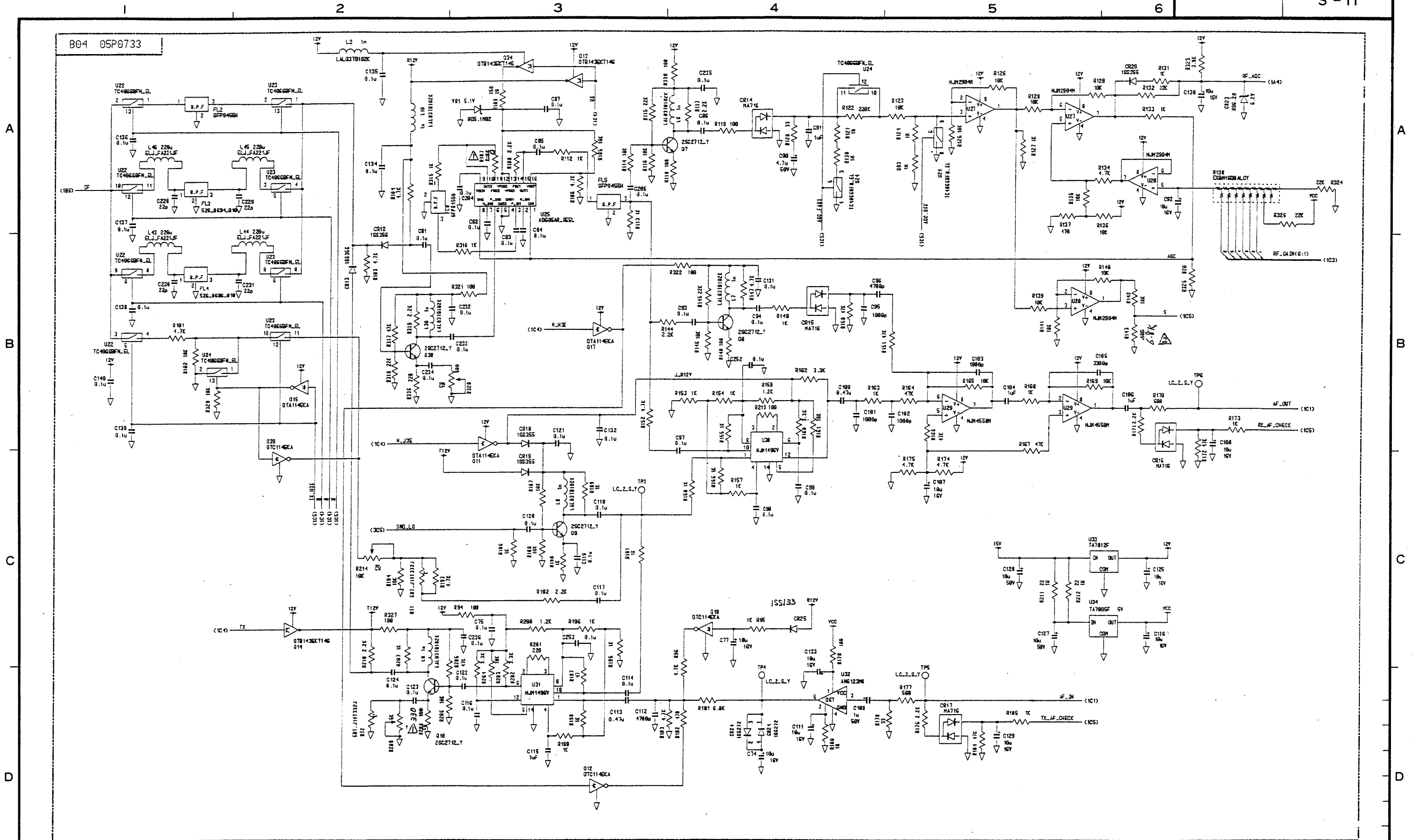

DRAWN 02/09/09 T. YAMASAKI	TYPE 05P0733 (2/3)
CHECKED 02/09/09 Y.K.	名称 TX/RX基板
APPROVED 02/09/09 Y.K.	回路図
SCALE MASS	MODEL FS-1570T/2570T 1B 4
Dwg No. C5636-K12-A	BLOCK No. NAME TX/RX PCB
	05-001-3862-2
	SCHMATIC DIAGRAM

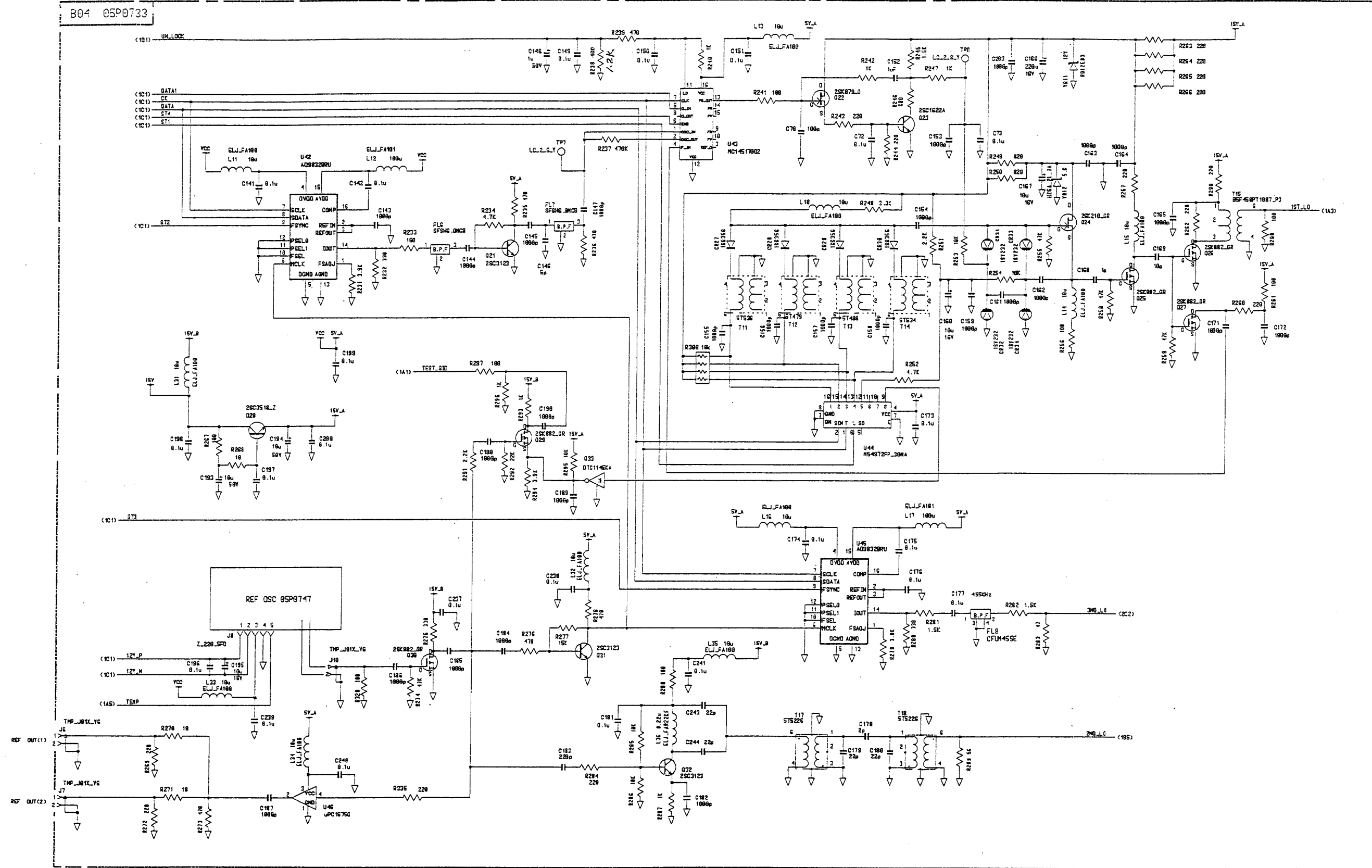

DRAWN 02/09/09 T. YAMASAKI	TYPE 05P0733 (3/3)
CHECKED 02/9/10 Y.K.	名称 TX/RX基板
APPROVED 02/9/10 Y.K.	回路図
SCALE MASS	NAME TX/RX PCB
Dwg No. C5636-K13- A	MODEL BLOCK No. FS-1570T/2570T 1B 4
	SCHEMATIC DIAGRAM

B10/B12
05P0746

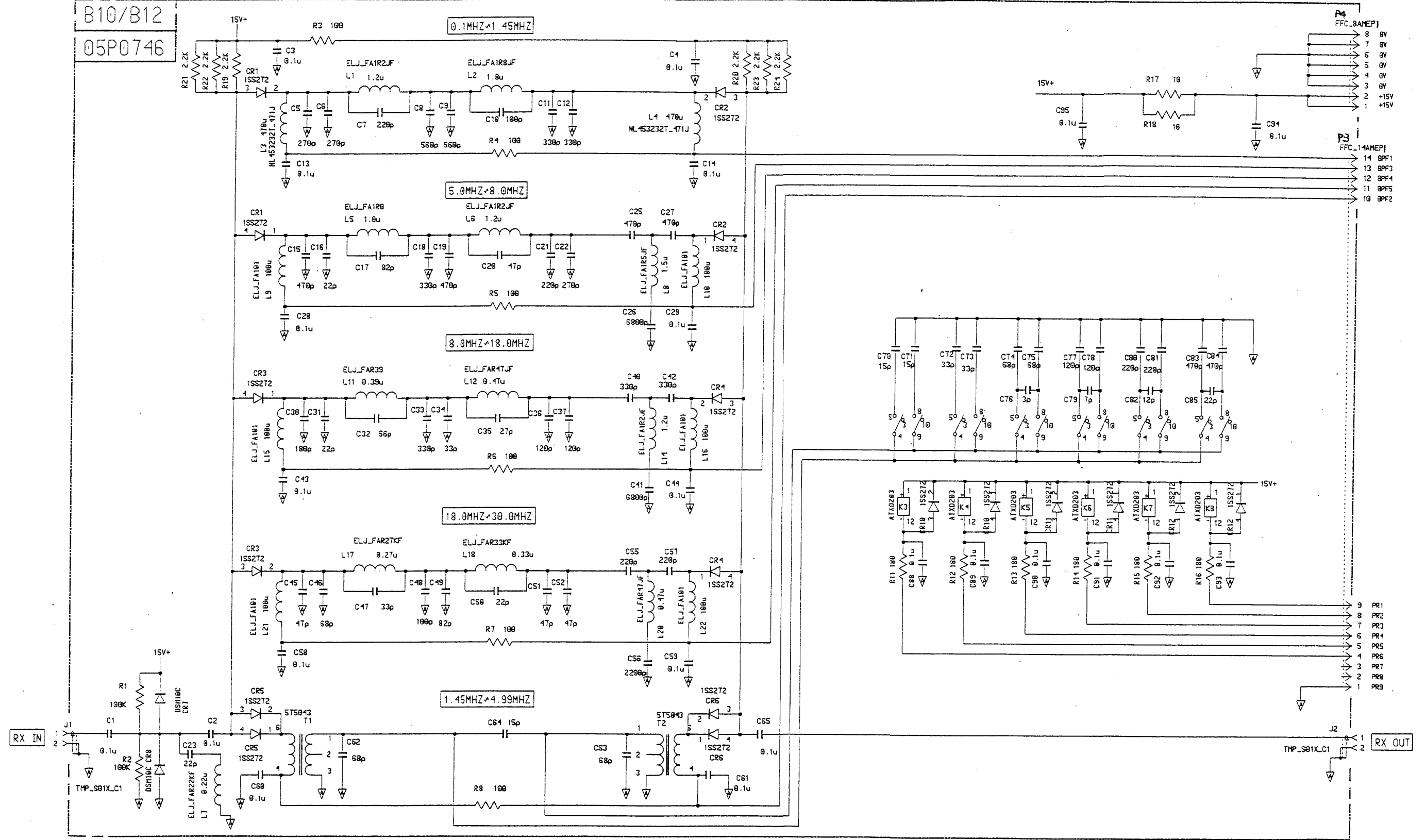

DRAWN 02/09/09 T. YAMASAKI	TYPE 05P0746
CHECKED 02/09/09 Y.K.	名称 PRESEL基板
APPROVED 02/09/09 Y.K.	回路図
SCALE MASS	NAME PRESEL PCB
Dwg No. C5636-K14- A	MODEL BLOCK No. FS-1570T/2570T 1B 10/12
	SCHEMATIC DIAGRAM

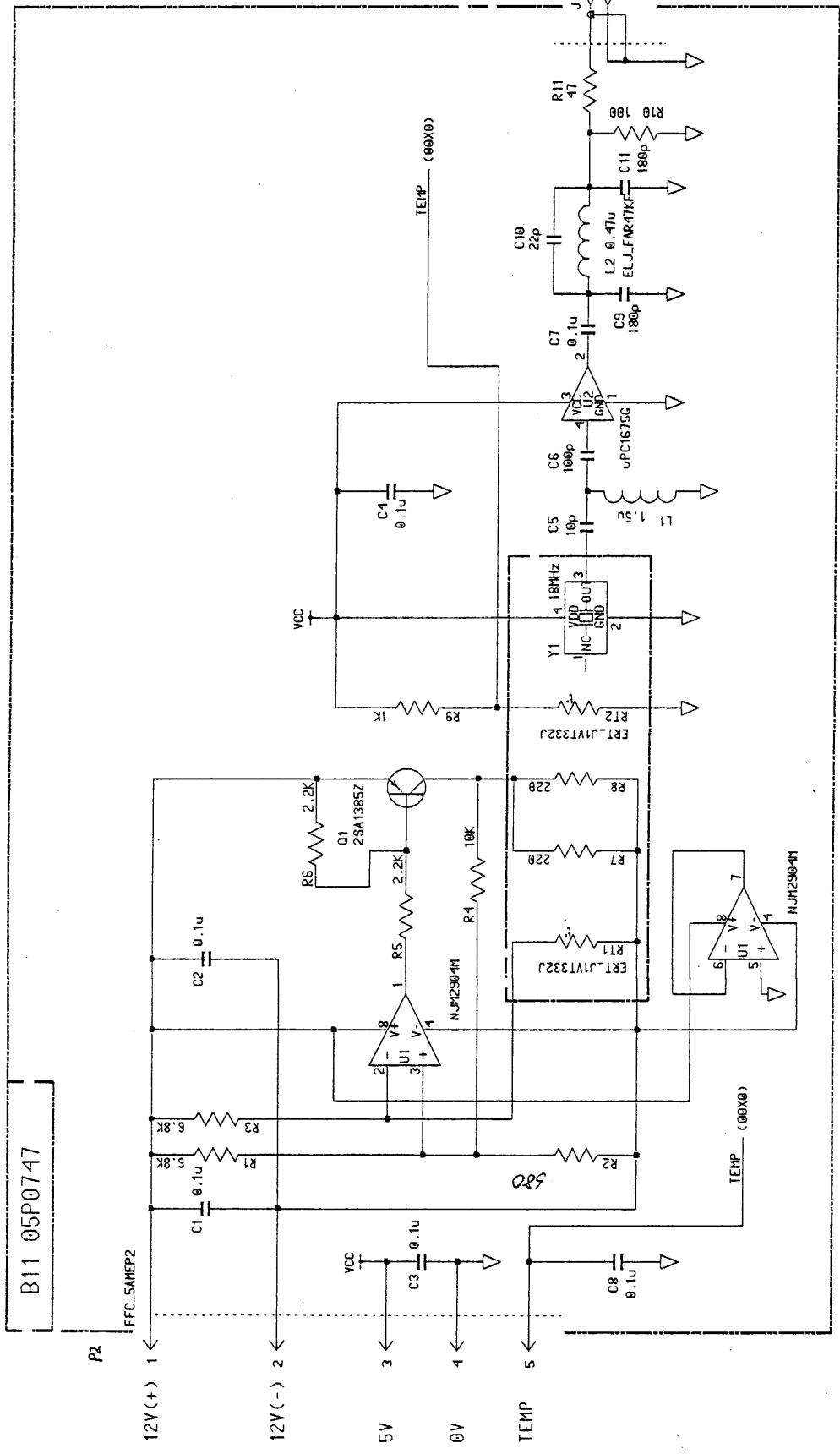

DRAWN 02/09/09 T. YAMASAKI		TYPE 05P0747
CHECKED 07/07/12 Y.K.		名称 REF 基板
APPROVED 07/07/12 Y.K.		回路図
SCALE MASS	MODEL FS-1570T/2570T 1B 11	NAME REF PCB
Dwg No. C5636-K15-A	BLOCK No.	SCHEMATIC DIAGRAM
	05-001-4445-2	

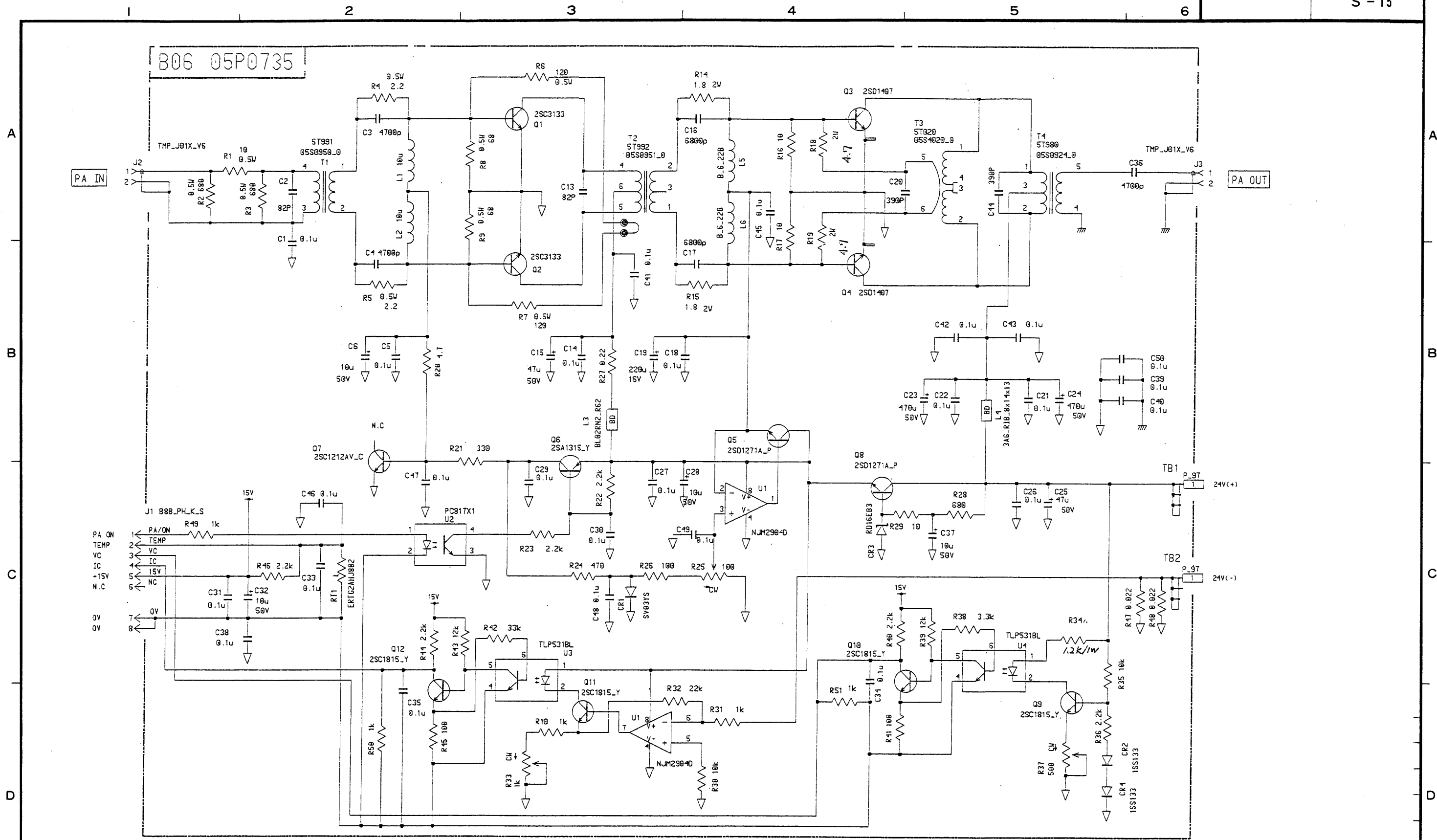

DRAWN 02/09/09 T. YAMASAKI	TYPE 05P0735
CHECKED 02/09/10 YIC	名称 PA基板
APPROVED 02/09/10 YIC	回路図
SCALE MASS	NAME PA PCB
Dwg No. C5636-K16- A	FS-1570T 1B 06 MODEL BLOCK No. SCHEMATIC DIAGRAM

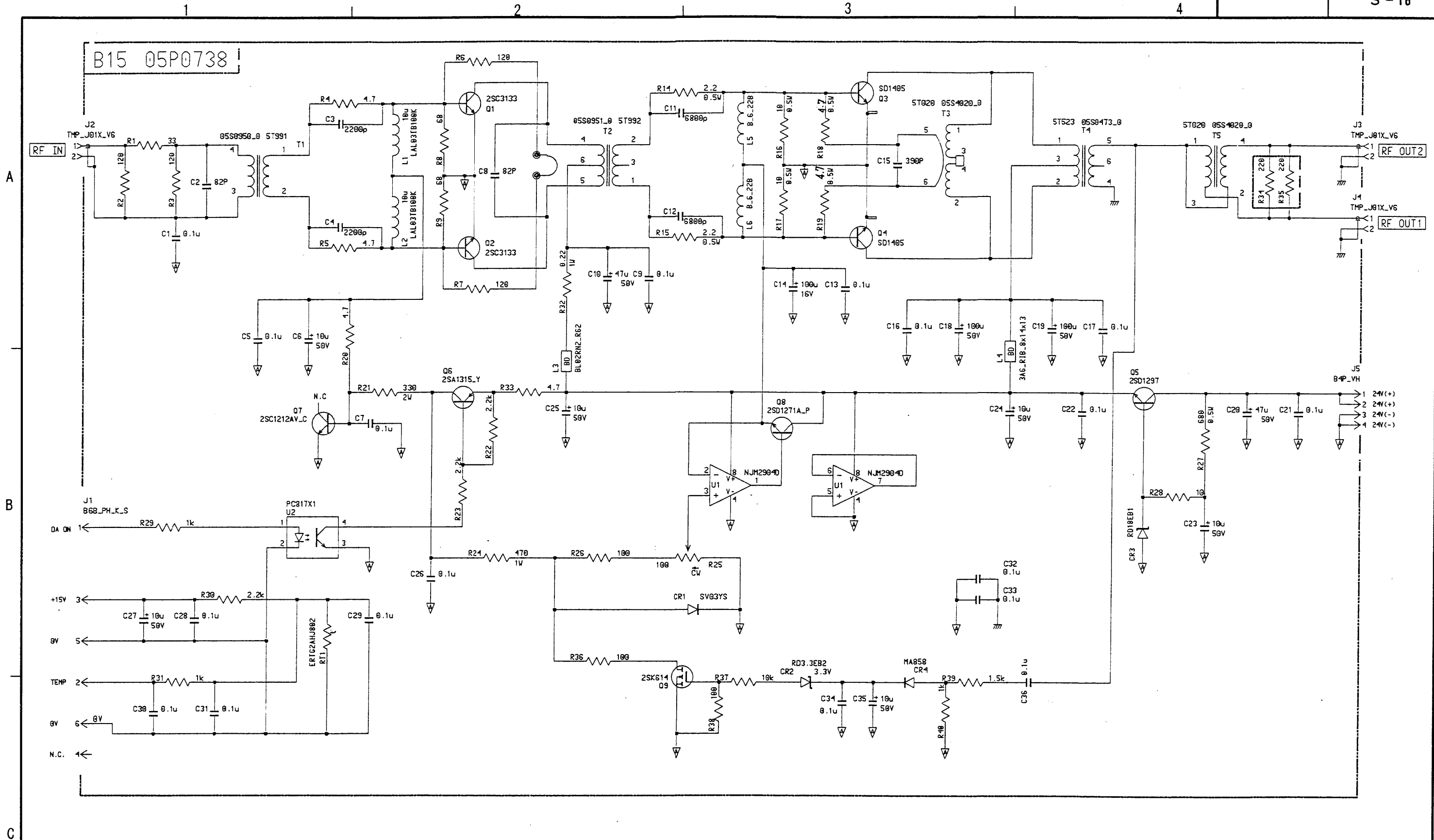

DRAWN 02/09/10 T. YAMASAKI	TYPE 05P0738
CHECKED 02/09/17 Y. K.	名称 DRV基板
APPROVED 02/09/17 Y. K.	回路図
SCALE MASS	MODEL BLOCK No.
Dwg No. C5637-K03-A	NAME DRV PCB
05-001-3874-1	SCHMATIC DIAGRAM

B06/17 05P0739

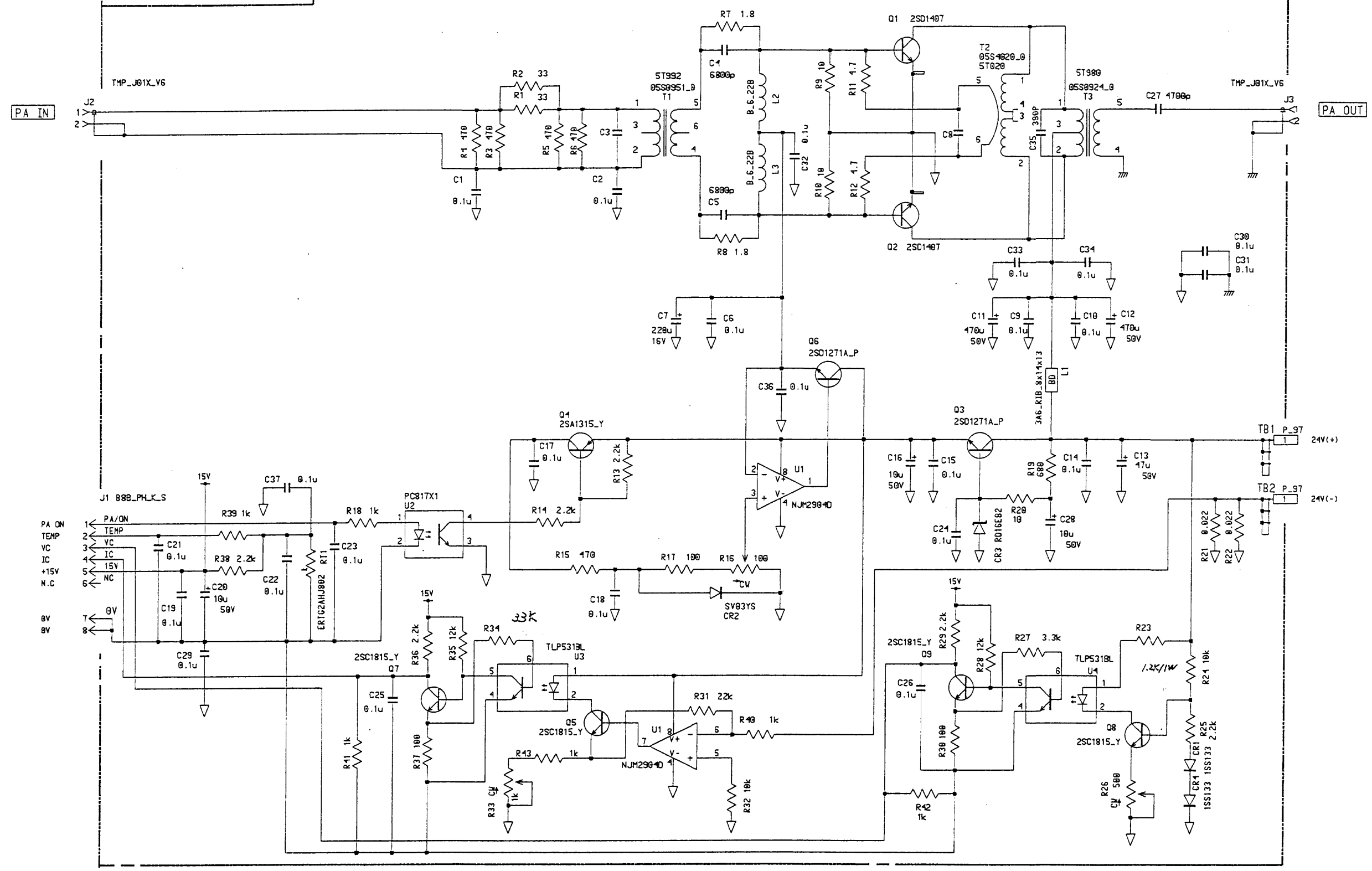

DRAWN 02/09/10 T. YAMASAKI	TYPE 05P0739
CHECKED 02/09/10 Y.K.	名称 PA基板
APPROVED 02/09/10 Y.K.	回路図
SCALE MASS	FS-2570T 1B 06/17 MODEL BLOCK No.
Dwg No. C5637-K04- A	05-001-3871-2 NAME PA PCB
SCHEMATIC DIAGRAM	

4

3

2

B04 05P0740 I

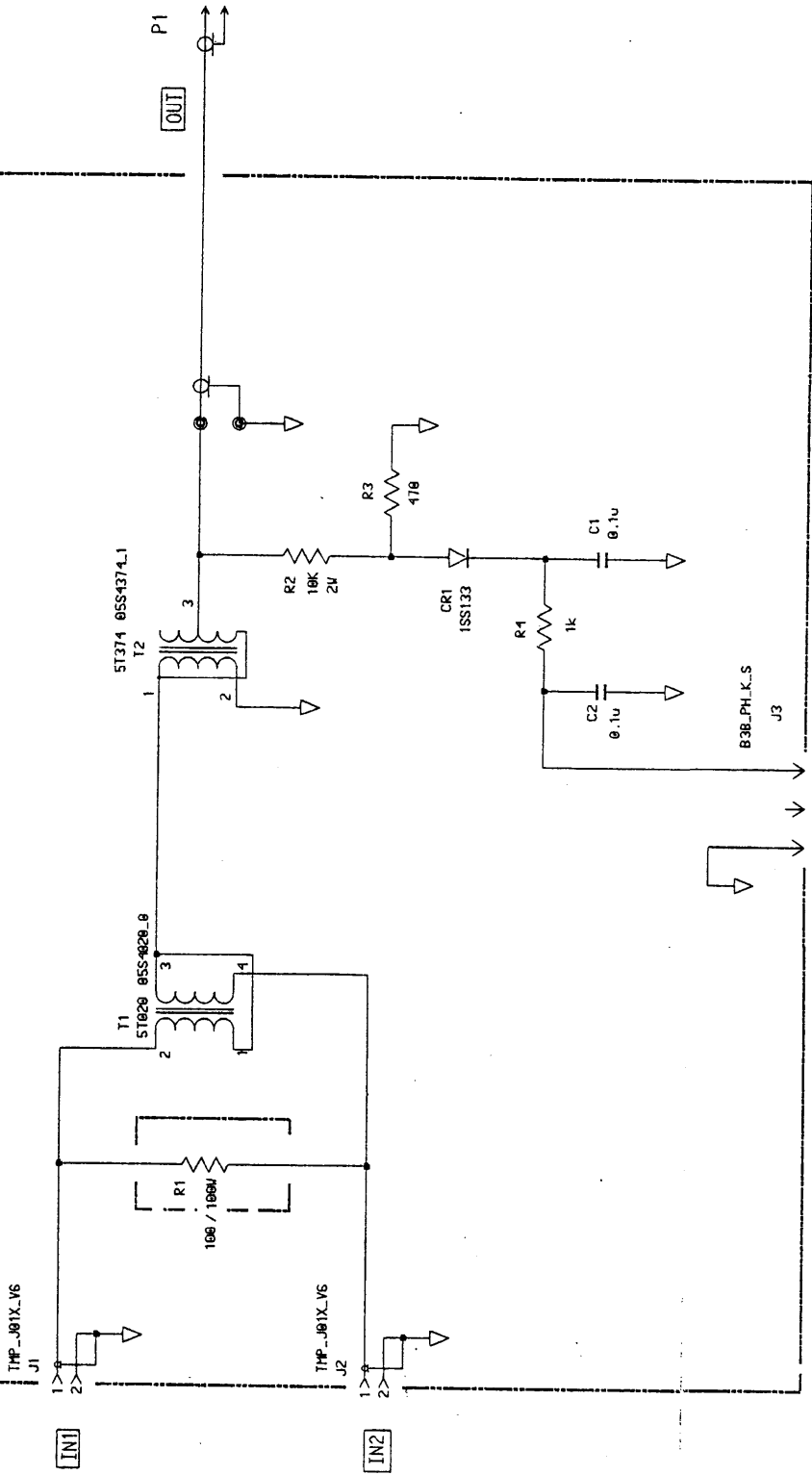

1
2
3
CHECK
N.C.
GND

DRAWN	02/09/10	T. YAMASAKI	TYPE	05P0740
CHECKED	02/25/10	Y. K.	名称	COMB基板
APPROVED	02/25/10	Y. K.	回路図	回路図
SCALE	MASS		MODEL	FS-2570T
			BLOCK No.	1B 04
			NAME	COMB PCB
			Dwg No.	C5637-K05-A
				05-001-3875-0
				SCHEMATIC DIAGRAM

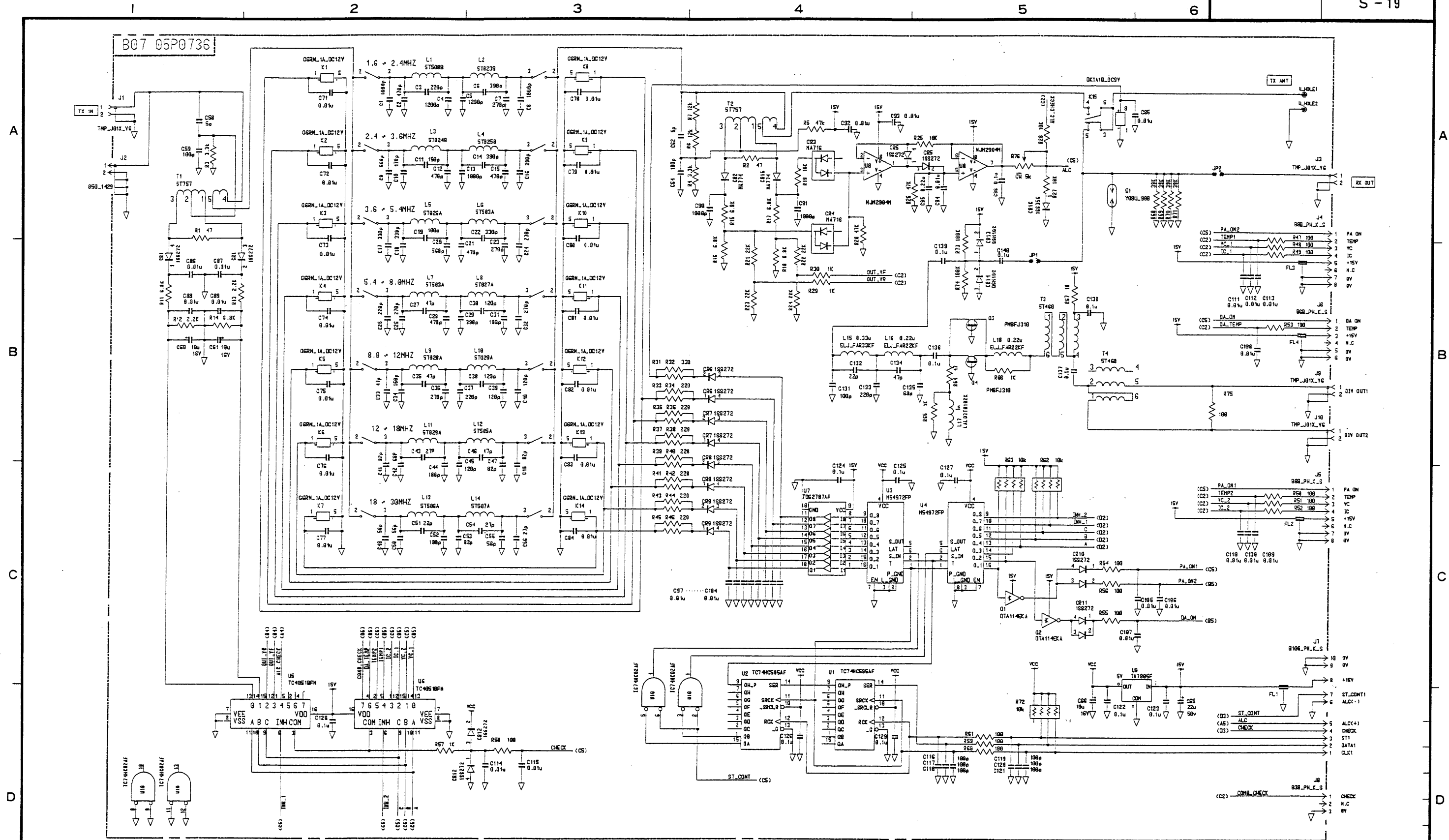

DRAWN 02/09/09 T. YAMASAKI	TYPE 05P0736
CHECKED 22/9/10 Y.K.	名称 TX-FIL基板
APPROVED 22/9/10 Y.K.	回路図
SCALE MASS	NAME TX-FIL PCB
Dwg No. C5636-K17- A	SCHEMATIC DIAGRAM
MODEL FS-1570T/2570T 1B 07	BLOCK No.
05-001-3865-0	05-001-3865-0

B13/14 05P0751

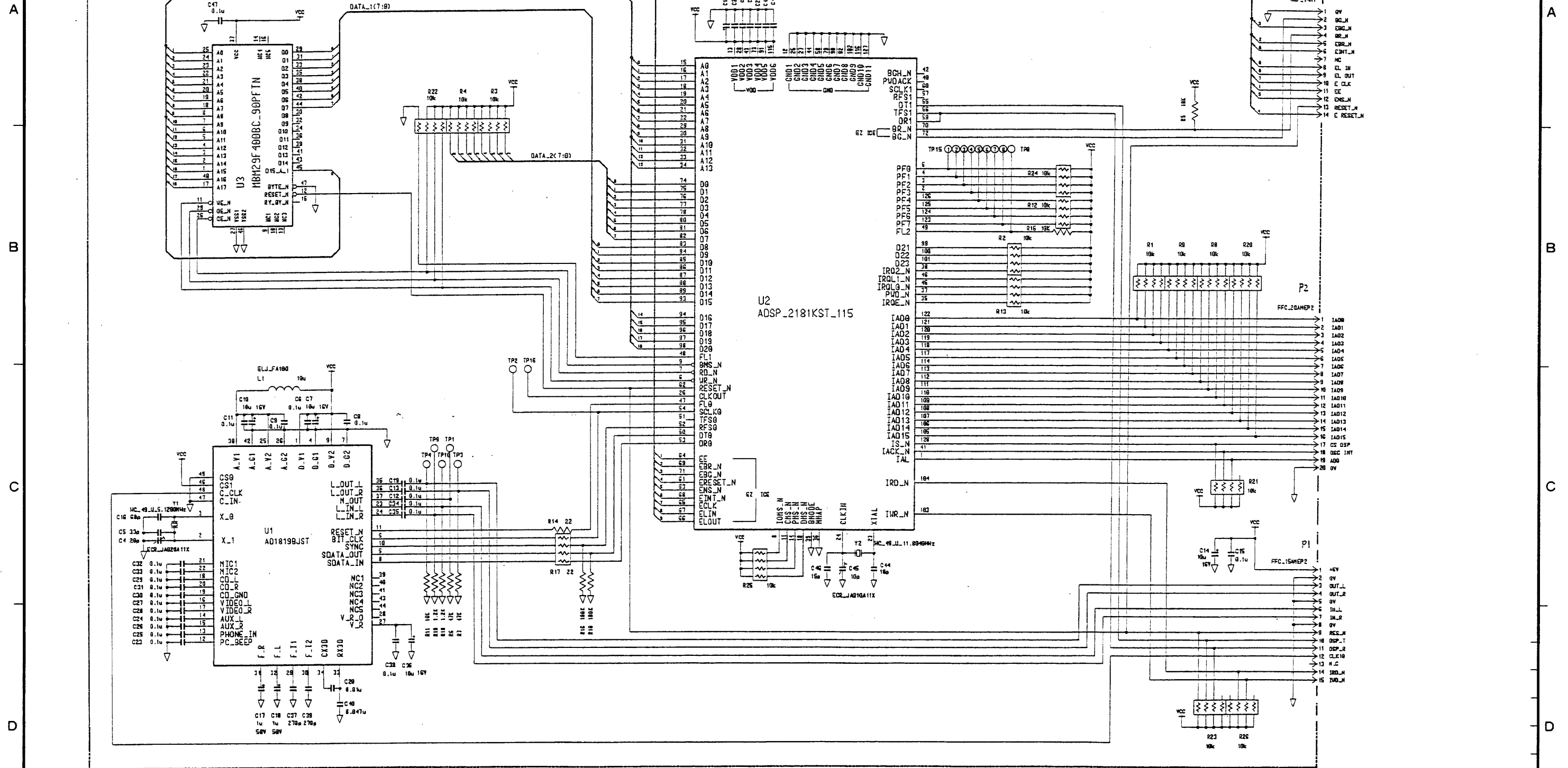

DRAWN 02/09/09 T. YAMASAKI	TYPE 05P0751
CHECKED 02/9/10 Y. Ki	名称 DSP基板
APPROVED 02/9/10 Y. Ki	FS-1570T/2570T 1B 13/14 回路図
SCALE MASS	MODEL BLOCK No.
Dwg No. C5636-K18- A	NAME DSP PCB
05-001-3883-1	SCHEMATIC DIAGRAM

B03 05P0732

A

B

C

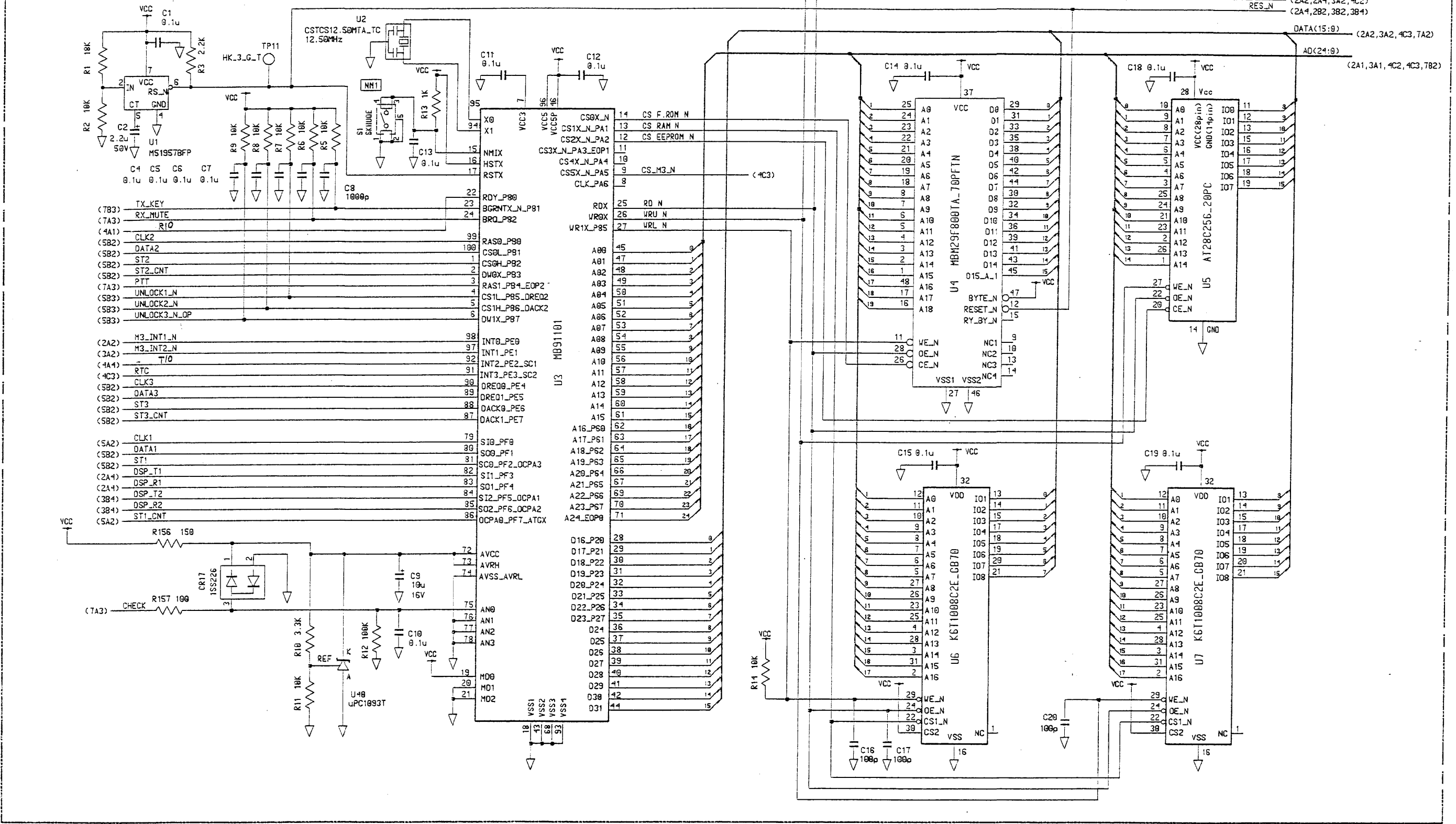

DRAWN 02/09/09 T. YAMASAKI	TYPE 05P0732 (1/7)
CHECKED 02/19/10 Y.K.	名称 T-CPU基板
APPROVED 02/19/10 Y.K.	回路図
SCALE MASS	NAME T-CPU PCB
Dwg No. C5636-K19- A	MODEL BLOCK No. FS-1570T/2570T 1B 03
	SCHEMATIC DIAGRAM

B03 05P0732

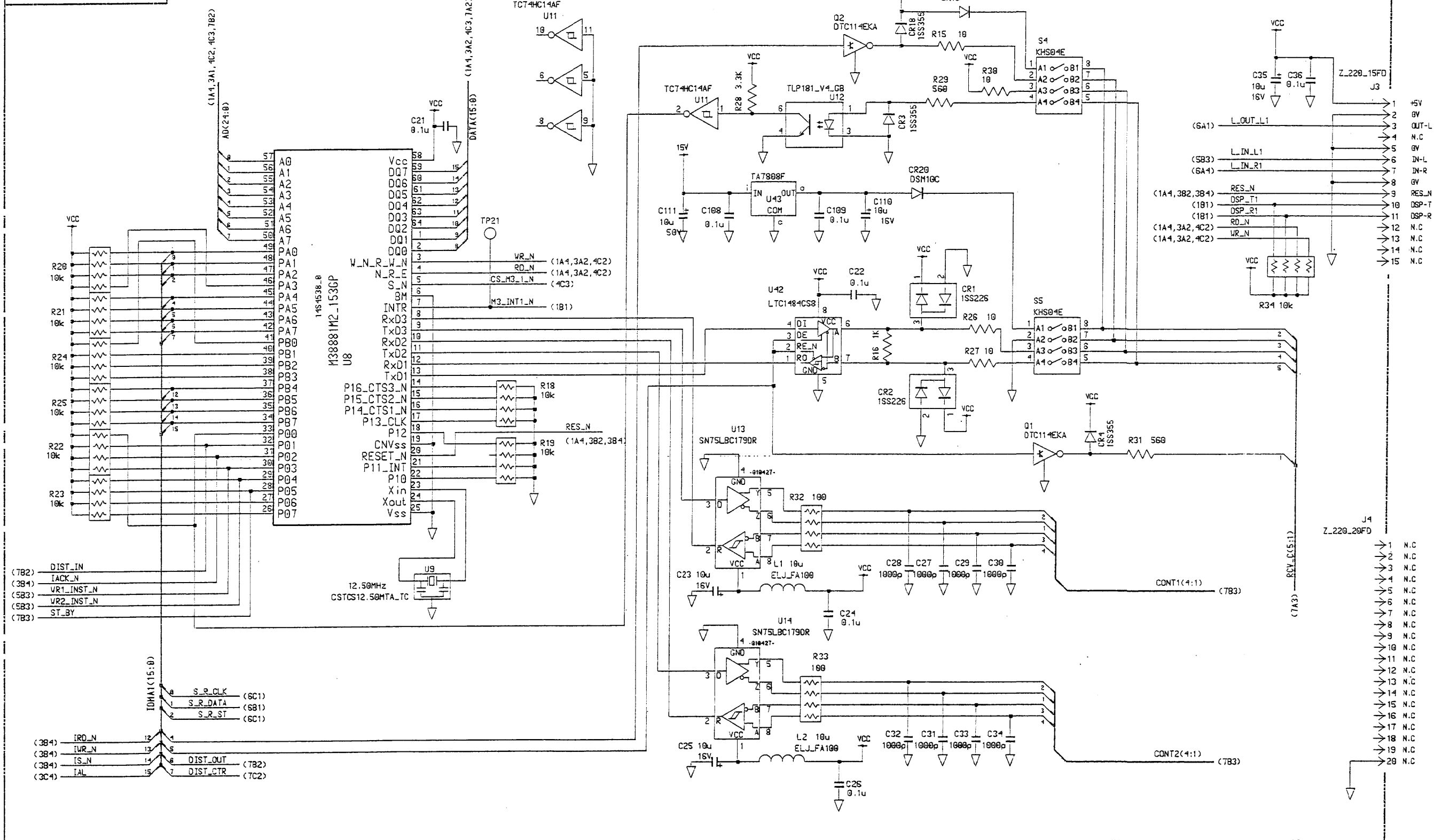

DRAWN 02/09/09 T. YAMASAKI	TYPE 05P0732 (2/7)
CHECKED 02/10/09 Y.K.	名称 T-CPU基板
APPROVED 02/10/09 Y.K.	FS-1570T/2570T 1B 03 回路図
SCALE MASS	MODEL BLOCK No.
Dwg No. C5636-K20-A	NAME T-CPU PCB
05-001-3861-0	SCHEMATIC DIAGRAM

B03 05P0732

A
B
C

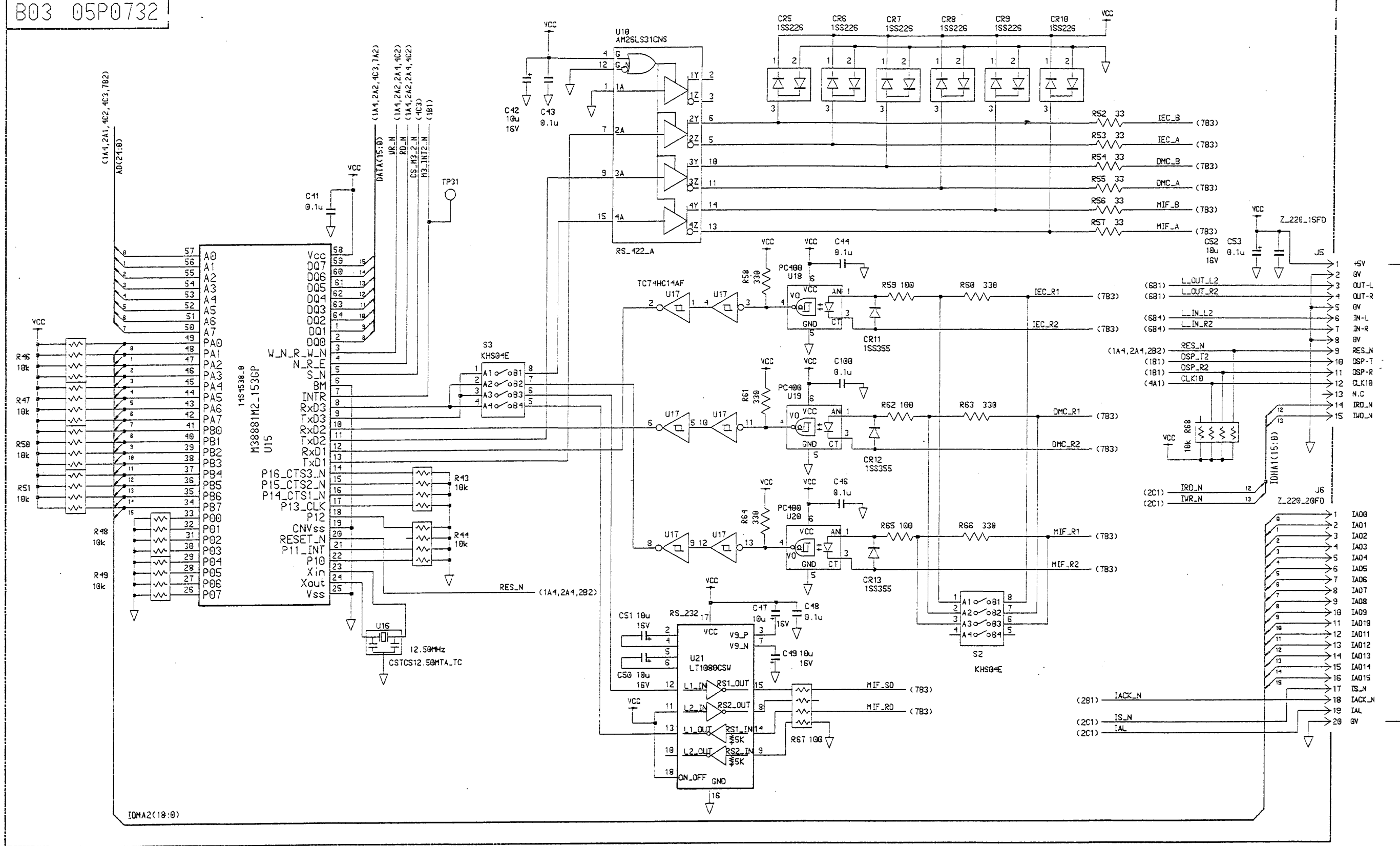

DRAWN 02/09/09 T. YAMASAKI	TYPE 05P0732 (3/7)
CHECKED 02/09/09 Y. K. Kim	名称 T-CPU基板
APPROVED 02/09/09 Y. K. Kim	回路図
SCALE MASS	MODEL FS-1570T/2570T 1B 03
Dwg No. C5636-K21-A	BLOCK No. 05-001-3861-0
	NAME T-CPU PCB
	SCHMATIC DIAGRAM

B03 05P0732

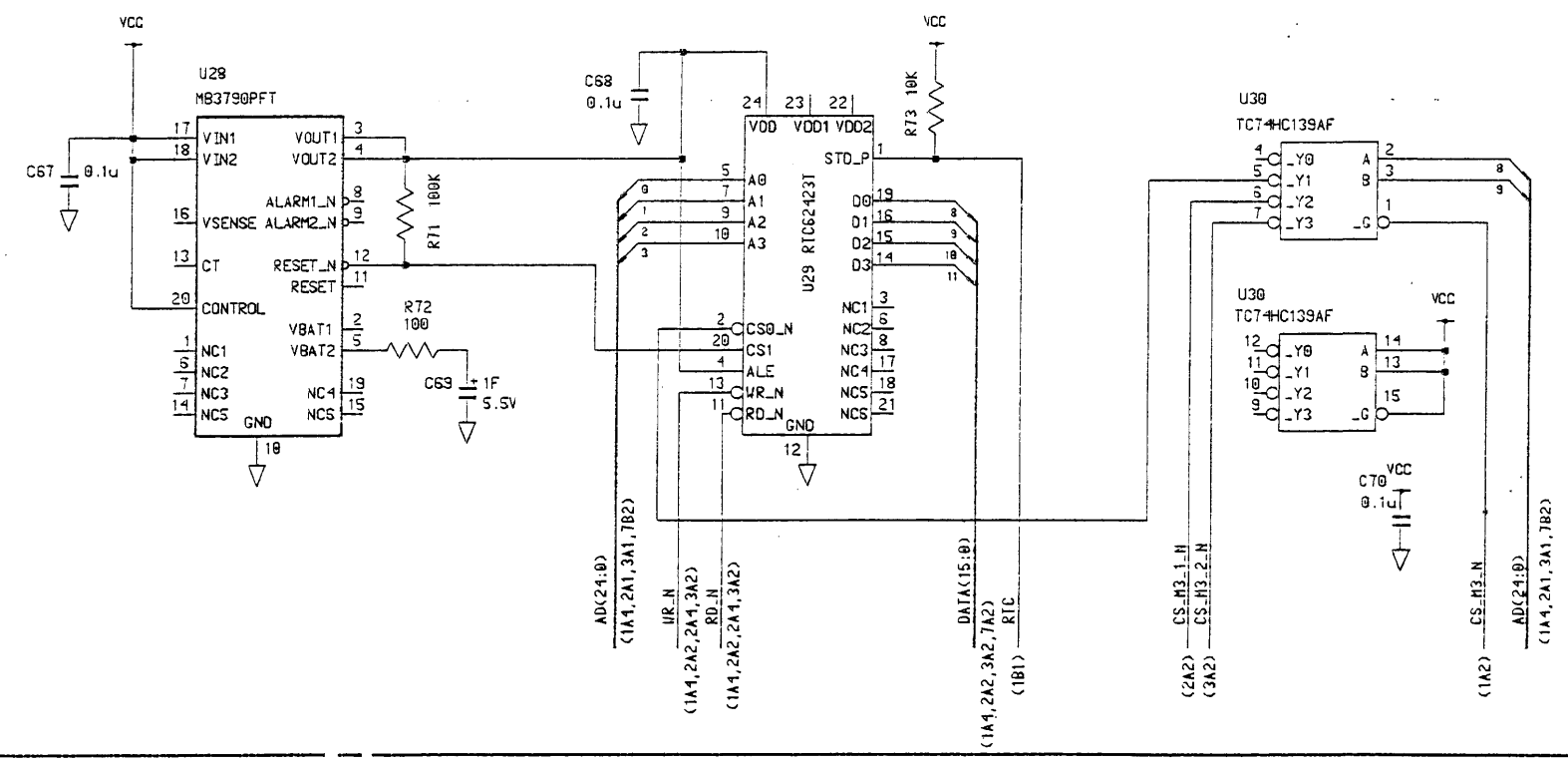
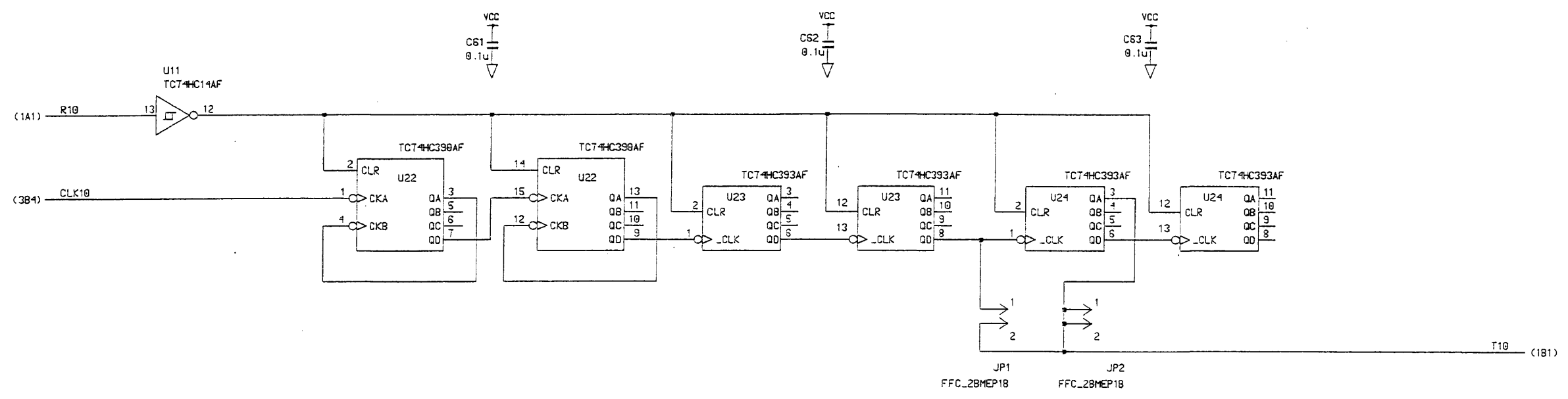

DRAWN 02/09/09 T. YAMASAKI	TYPE 05P0732 (4/7)
CHECKED 02/09/09 YIC	名称 T-CPU基板
APPROVED 02/09/09 YIC	回路図
SCALE MASS	MODEL FS-1570T/2570T 1B 03
Dwg No. C5636-K22-A	BLOCK No. 05-001-3861-0
	NAME T-CPU PCB
	SCHEMATIC DIAGRAM

B03 05P0732

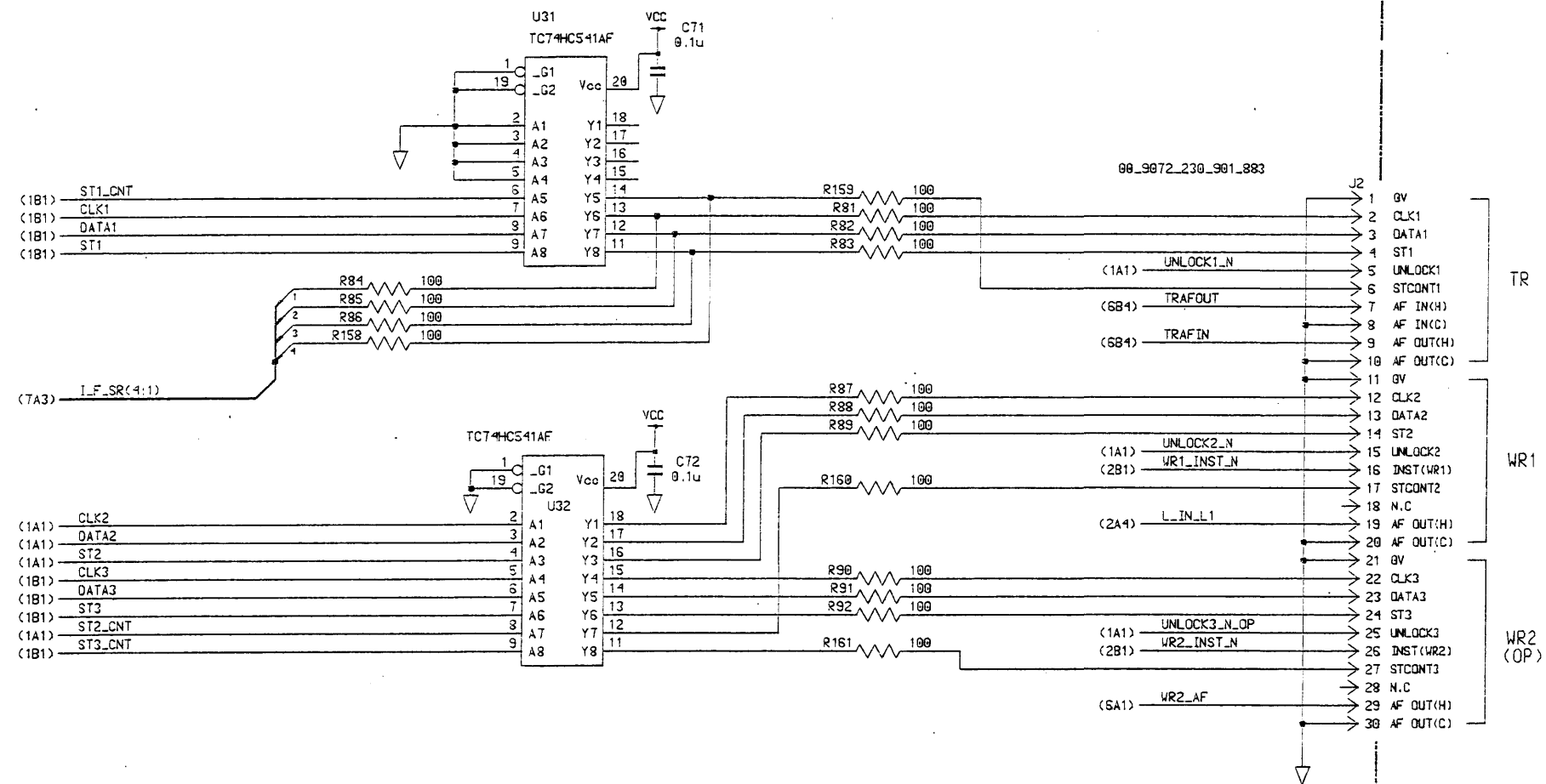

DRAWN 02/09/09 T. YAMASAKI	TYPE 05P0732 (5/7)
CHECKED 02/09/09 T.K.	名称 T-CPU基板
APPROVED 02/09/09 T.K.	回路図
SCALE MASS	MODEL FS-1570T/2570T 1B 03
Dwg No. C5636-K23- A	BLOCK No. NAME T-CPU PCB
05-001-3861-0	SCHEMATIC DIAGRAM

B03 05P0732

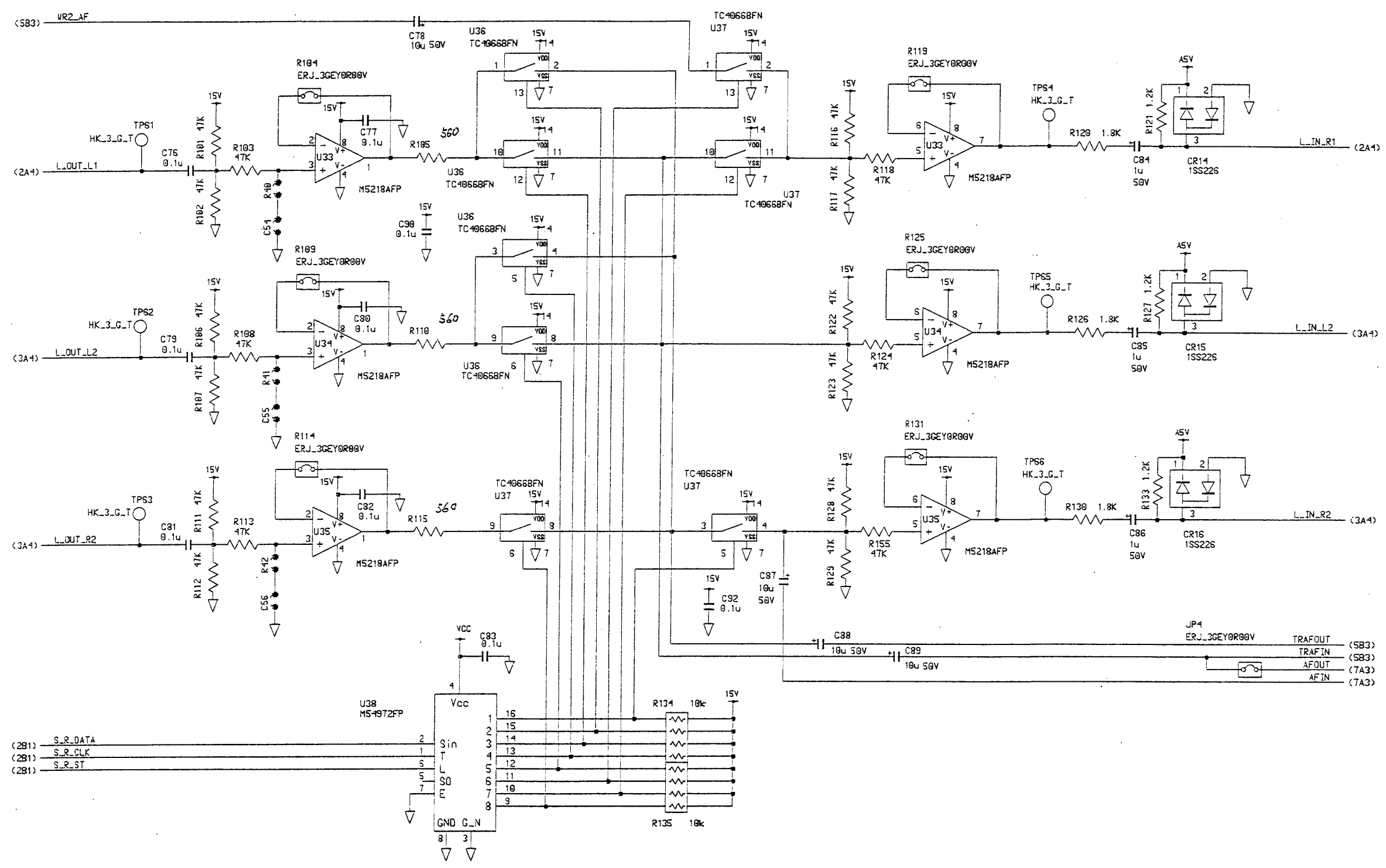

DRAWN 02/09/09 T. YAMASAKI	TYPE 05P0732 (6/7)
CHECKED 02/09/09 Y.K.	名称 T-CPU基板
APPROVED 02/09/09 Y.K.	回路図
SCALE MASS	MODEL FS-1570T/2570T 1B 03
Dwg No. C5636-K24- A	BLOCK No. 05-001-3861-0
	NAME T-CPU PCB
	SCHMATIC DIAGRAM

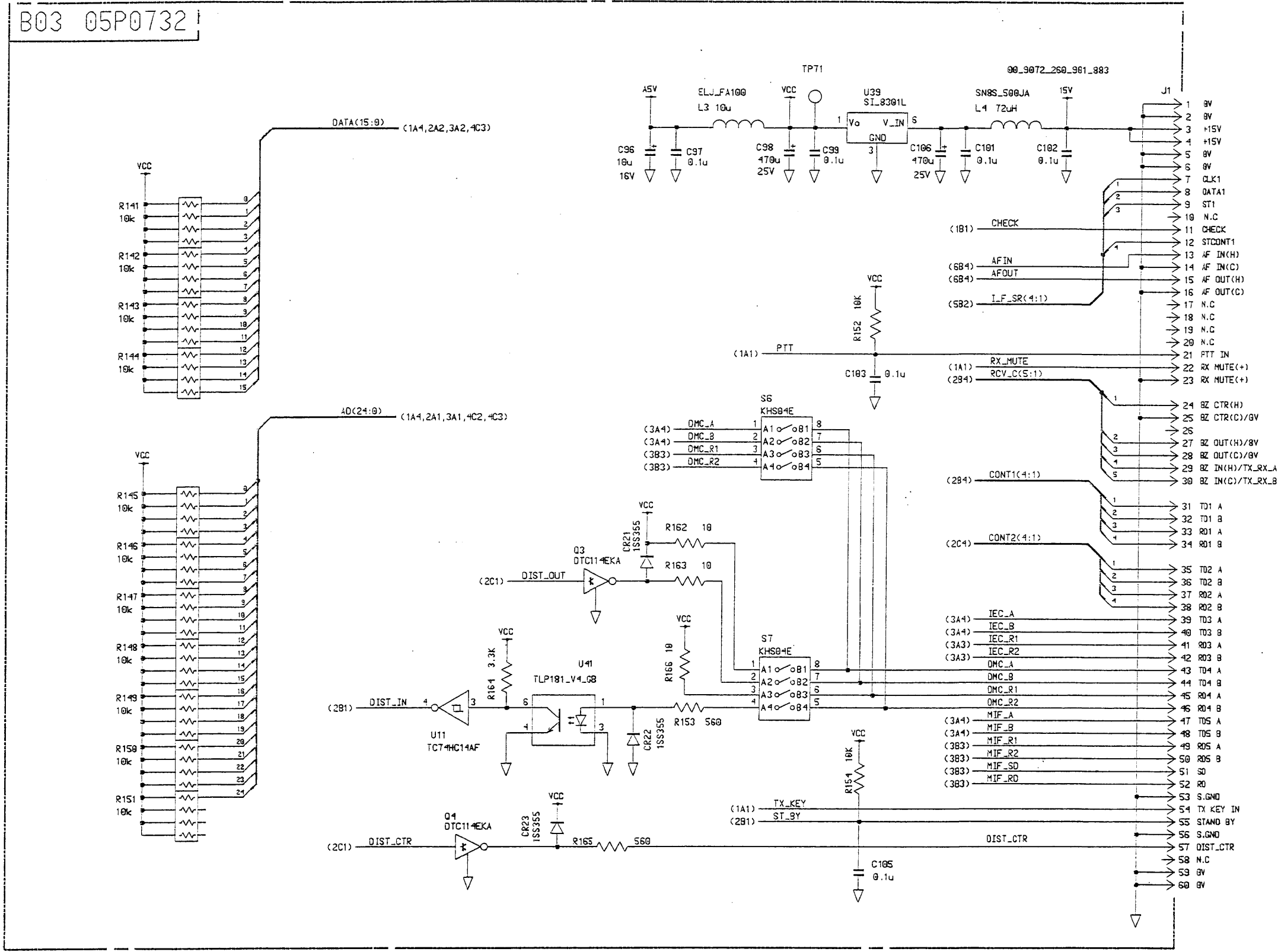

DRAWN 02/09/09 T. YAMASAKI	TYPE 05P0732 (7/7)
CHECKED 02/09/09 Y. K.	名称 T-CPU基板
APPROVED 02/09/09 Y. K.	回路図
SCALE MASS	MODEL BLOCK No.
Dwg No. C5636-K25-A	NAME T-CPU PCB
05-001-3861-0	SCHMATIC DIAGRAM

B08 05P0737

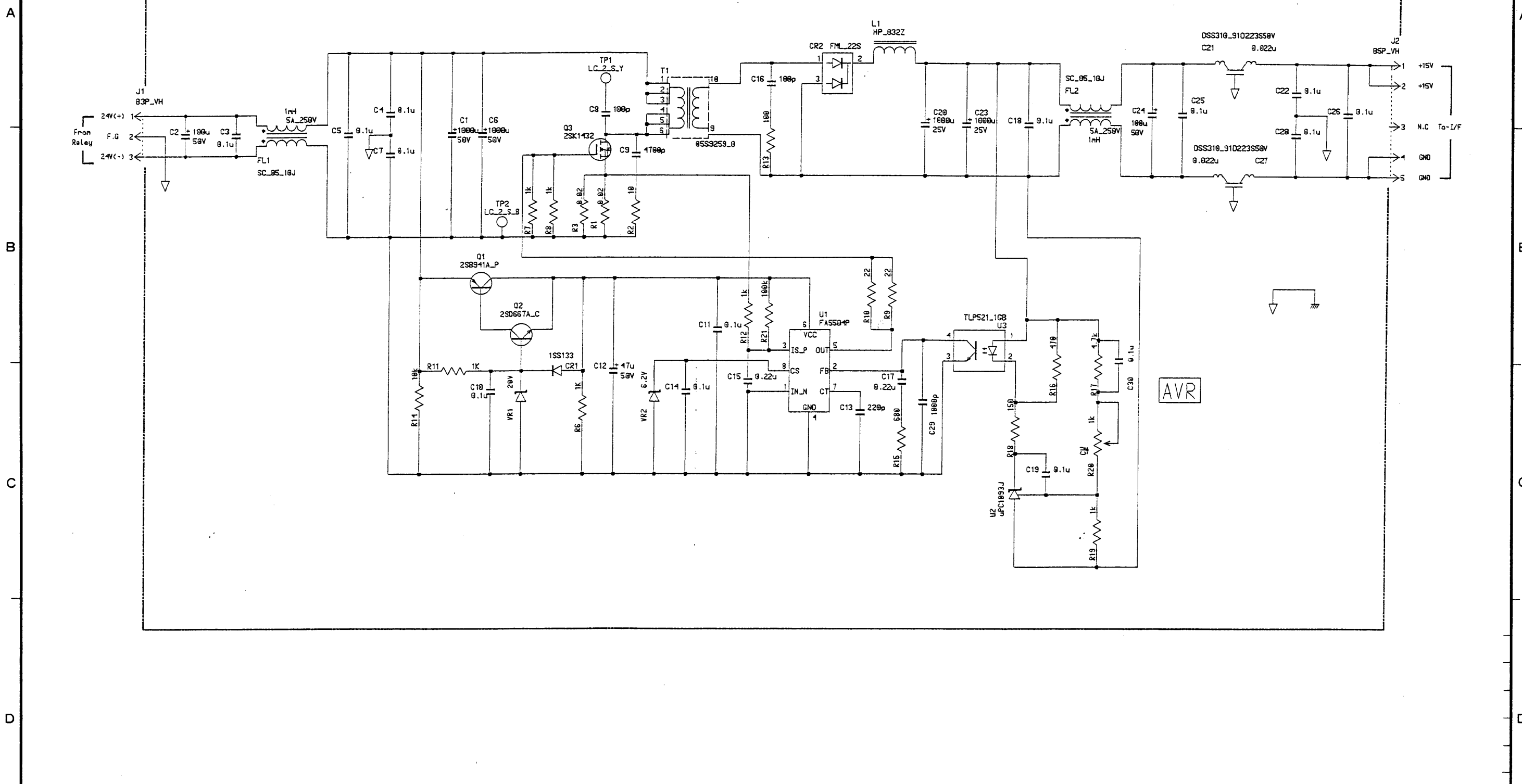

DRAWN 02/04/26 T. YAMASAKI	TYPE 05P0737
CHECKED 02/14/26 Y. K.	名称 SW REG基板
APPROVED 02/14/26 Y. K.	回路図
SCALE MASS	MODEL BLOCK No.
Dwg No. C5636-K04- A	NAME SW REG PCB
05-001-3866-0	SCHEMATIC DIAGRAM

B05/B18 05P0734

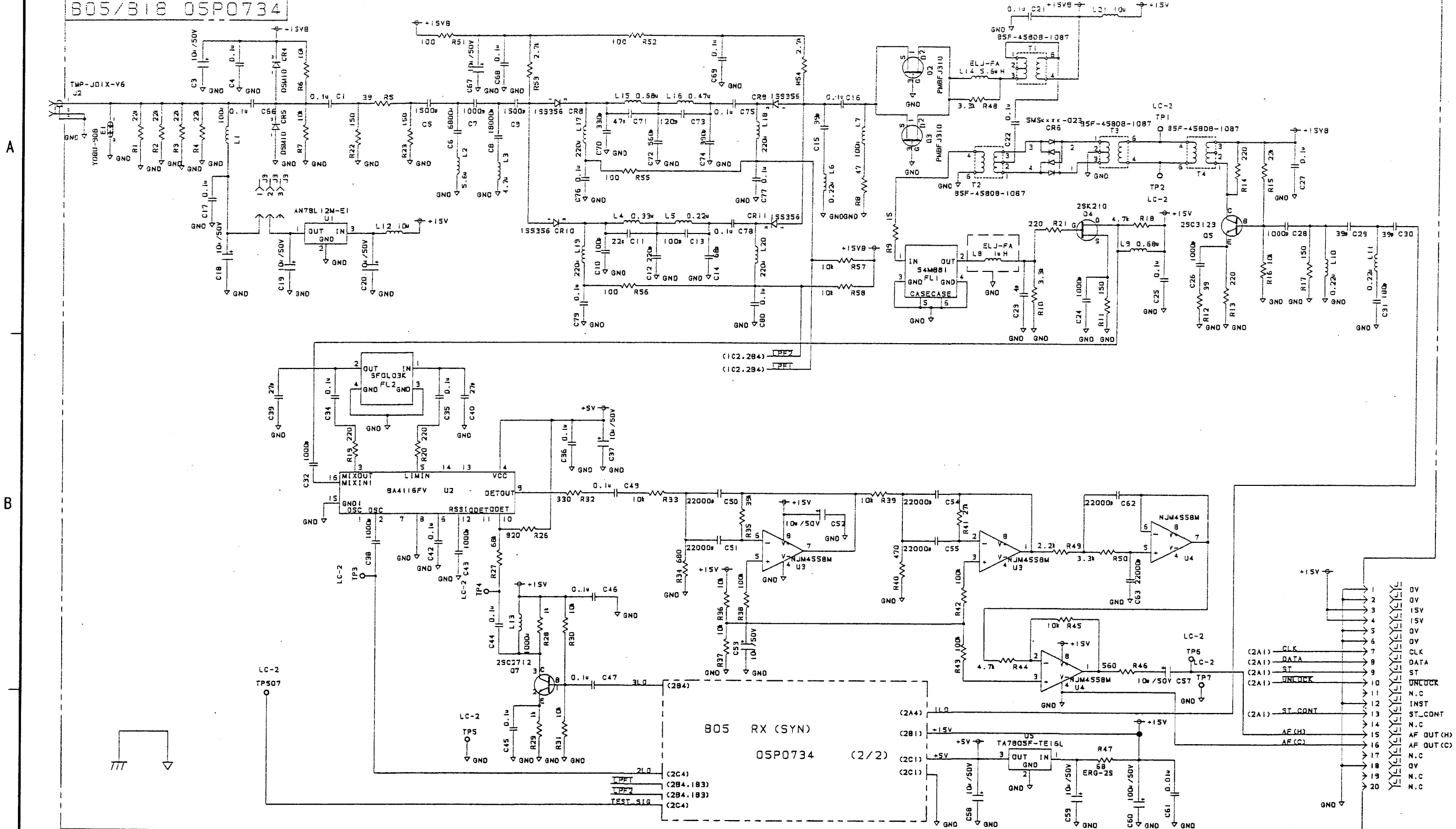

DRAWN 02/09/10 T. YAMASAKI	TYPE 05P0734 (1/2)
CHECKED 02/19/10 Y.K.	名称 W/R基板
APPROVED 02/19/10 Y.K.	回路図
SCALE MASS	MODEL FS-1570T/2570T 1B 05/18
Dwg No. C5636-K26- A	NAME W/R PCB
	BLOCK No. 05-001-3863-0
	SCHMATIC DIAGRAM

605/B18-05P0734

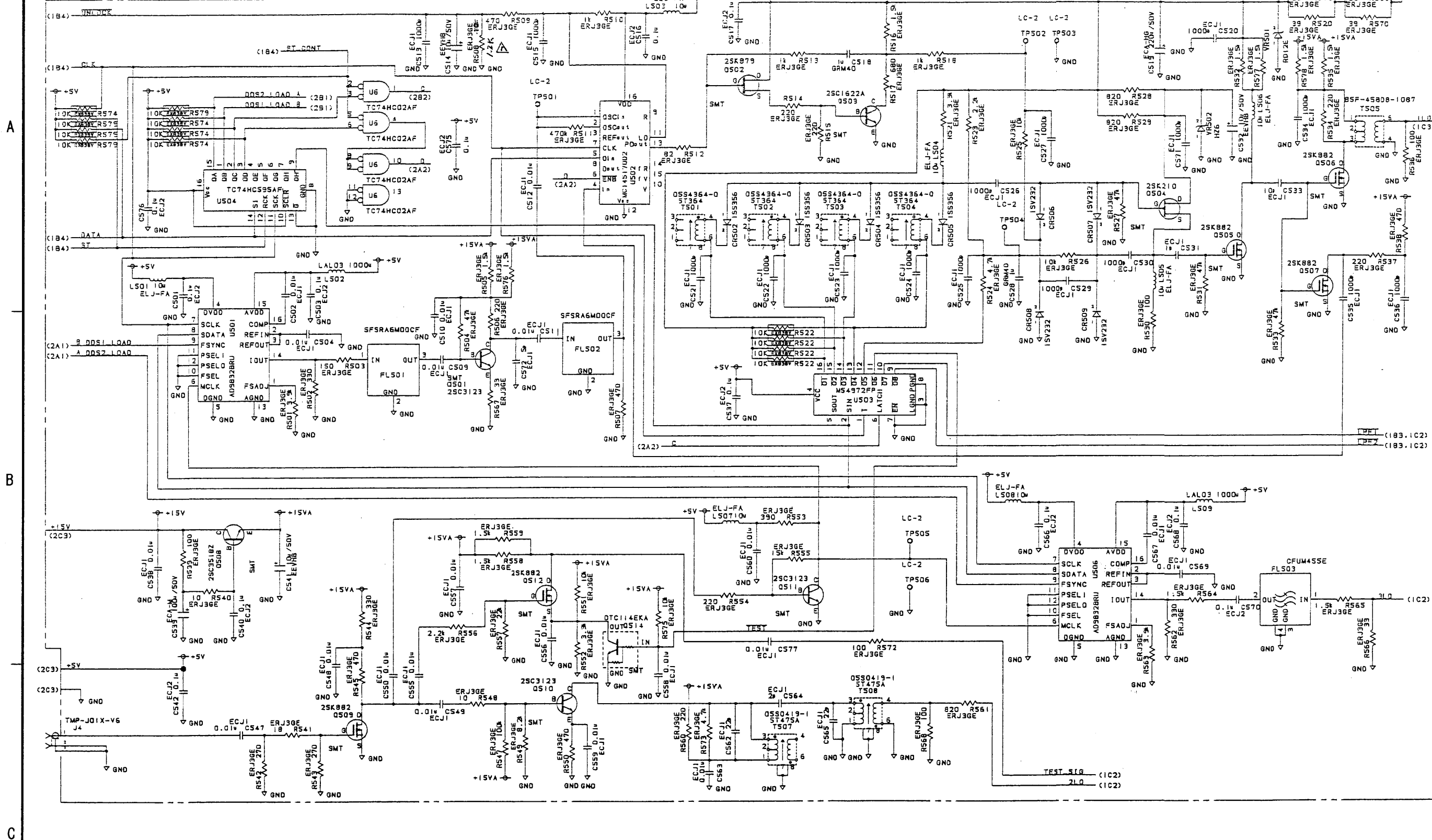

DRAWN 02/09/10 T. YAMASAKI	TYPE 05P0734 (2/2)
CHECKED 02/17/10 Y.K.	名称 W/R基板
APPROVED 02/19/10 Y.K.	FS-1570T/2570T 1B 05/18 回路図
SCALE MASS	MODEL BLOCK No.
Dwg No. C5636-K27-A	NAME W/R PCB
	05-001-3863-1 SCHEMATIC DIAGRAM

B09 M.B 05P0742

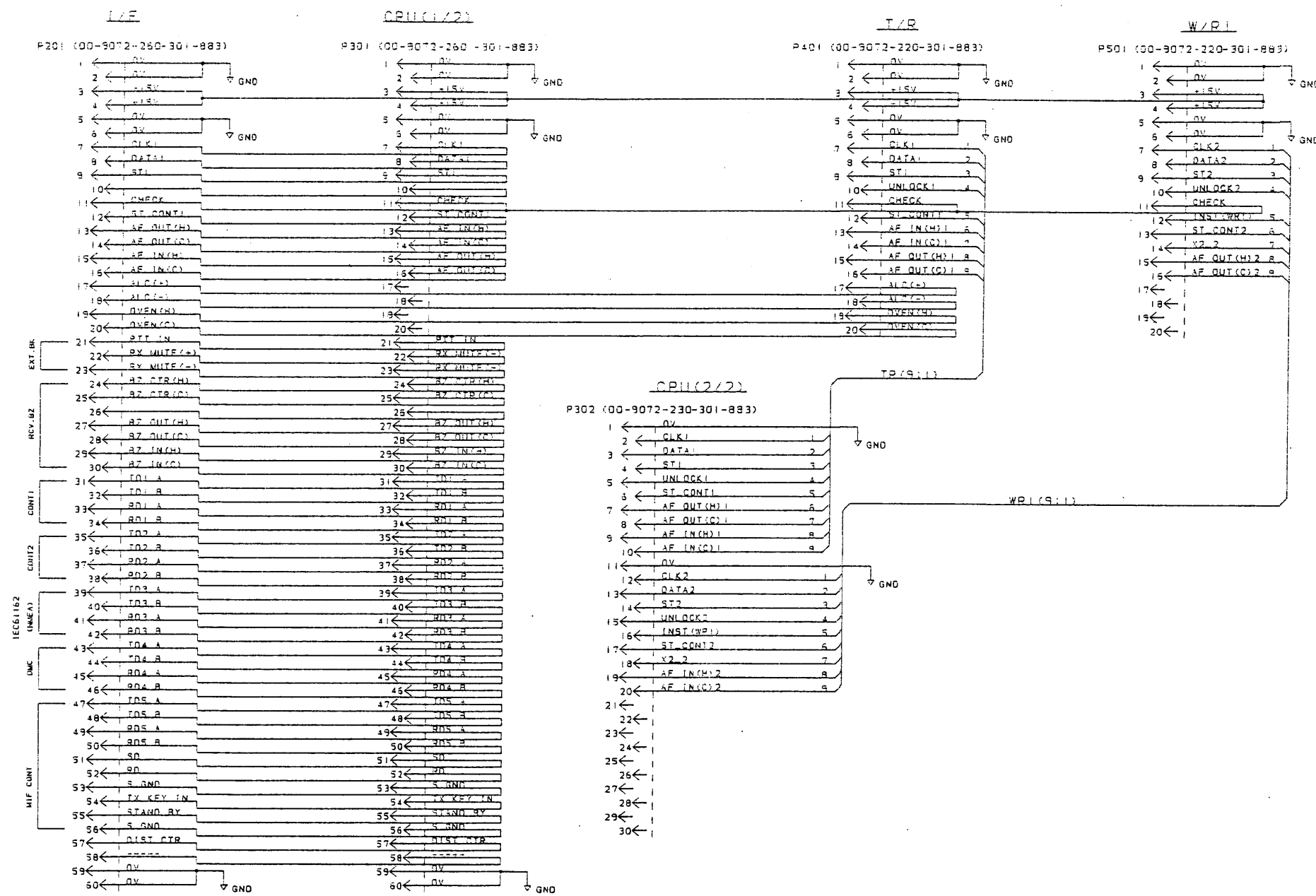

DRAWN 02/09/10 T. YAMASAKI	TYPE 05P0742
CHECKED 02/19/17 Y.K.	名称 M. B基板
APPROVED 02/19/17 Y.K.	回路図
SCALE MASS	MODEL BLOCK No.
Dwg No. C5636-K28- A	NAME M. B PCB
05-001-3867-0	SCHEMATIC DIAGRAM

B09 M.B 05P0743

A

B

C

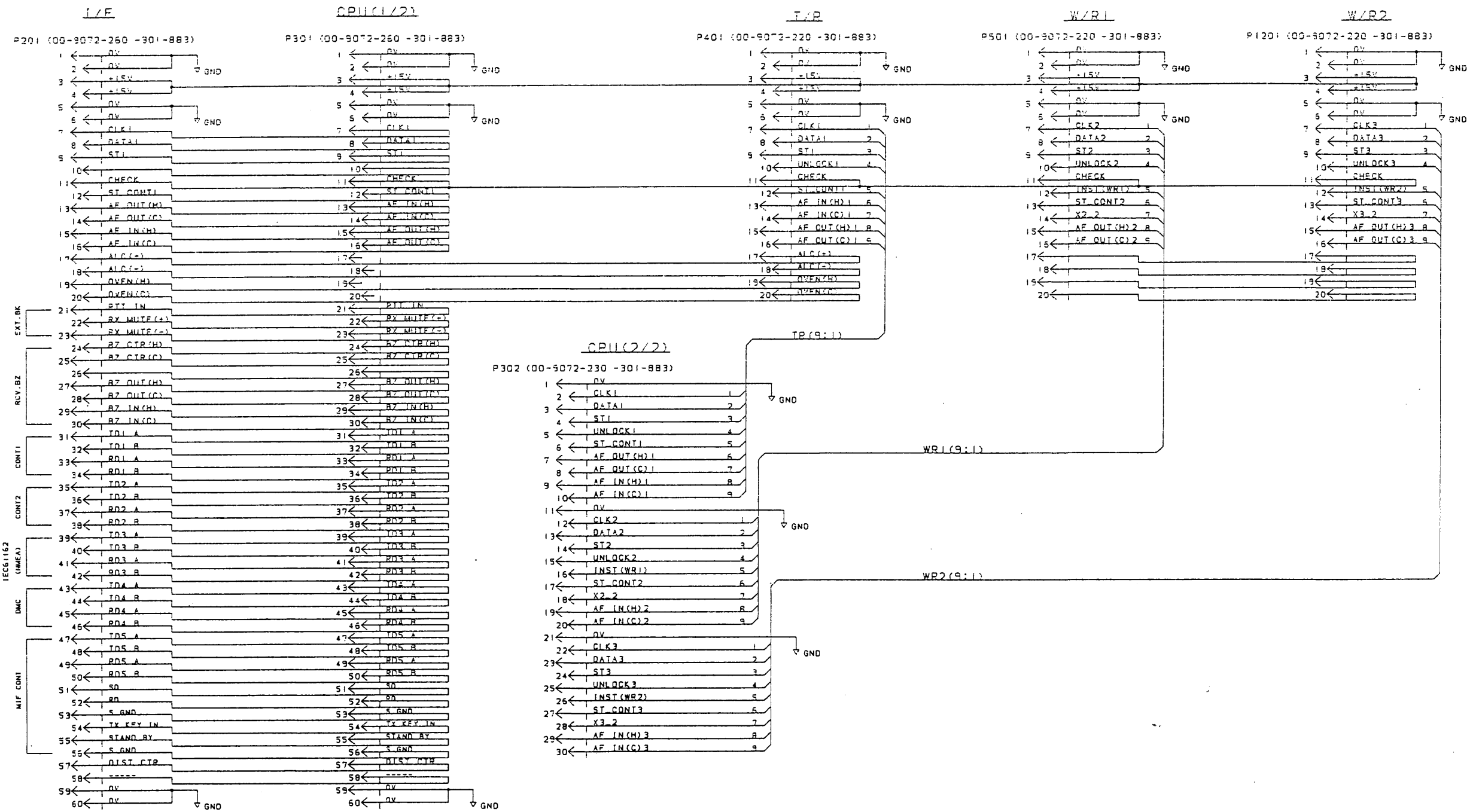

DRAWN 02/09/10 T. YAMASAKI	TYPE 05P0743
CHECKED 02/09/10 Y. K.	名称 M. B基板
APPROVED 02/09/10 Y. K.	回路図
SCALE MASS	MODEL BLOCK No.
Dwg No. C5637-K06- A	NAME M. B PCB
05-001-3873-0	SCHMATIC DIAGRAM

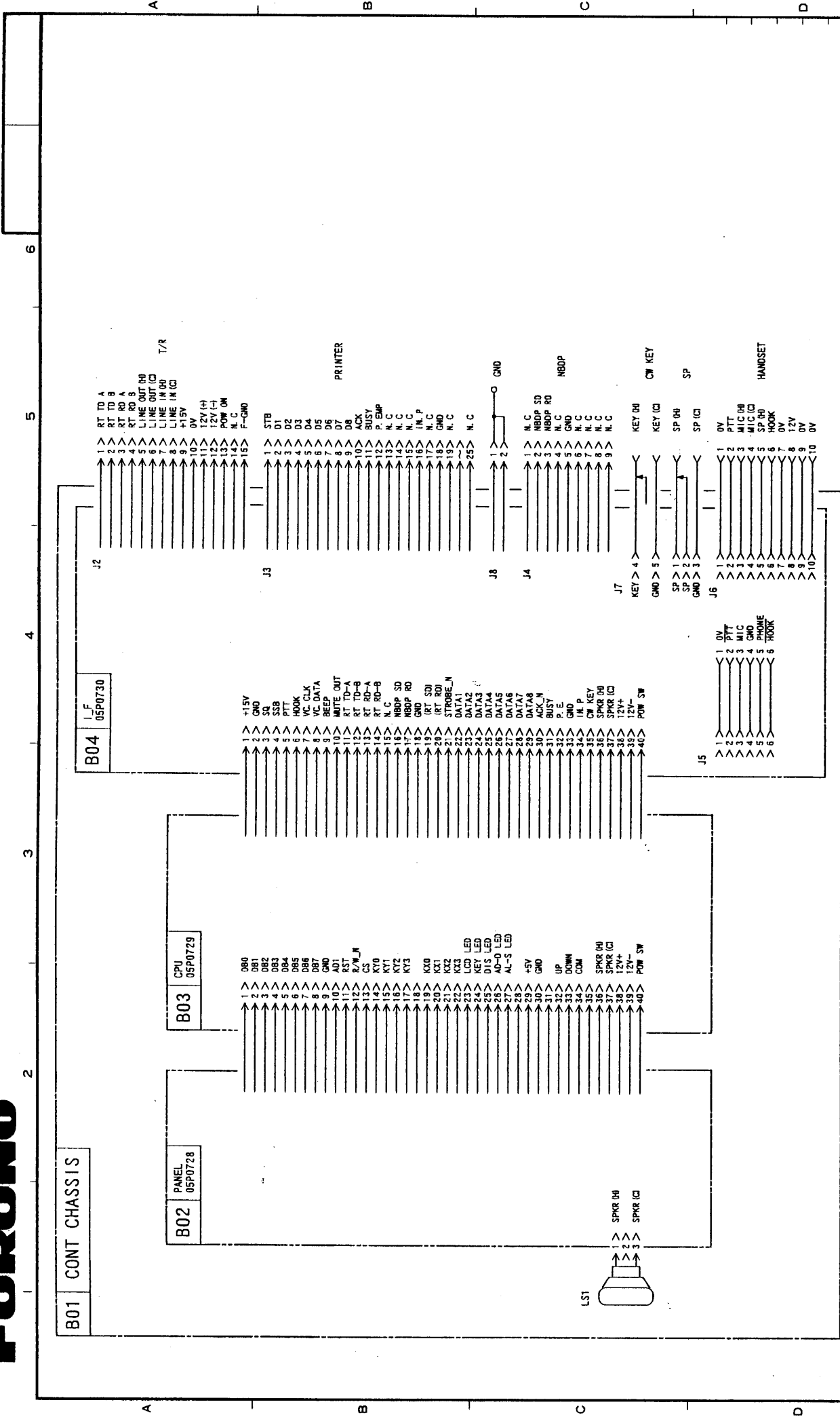

DRAWN 02/04/26 T. YAMASAKI	TYPE FS-2570C
CHECKED 02/02/26 Y. K.	名称 コントロールユニット
APPROVED 02/04/26 Y. K.	回路図
SCALE	MODEL
Dwg No. C5636-K03-A	BLOCK No.
	CONTROL UNIT
	SCHEMATIC DIAGRAM

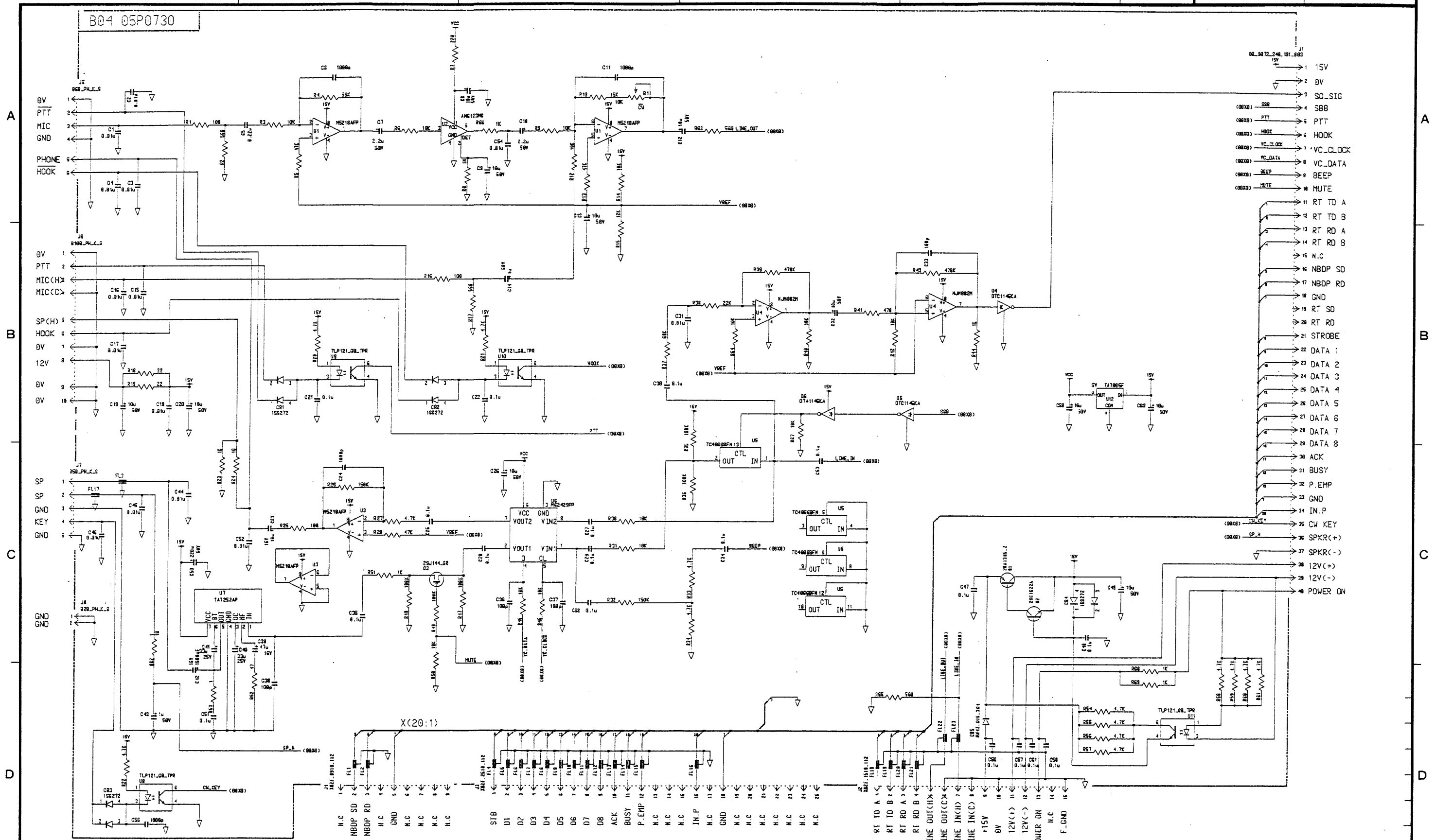

DRAWN 02/09/10 T. YAMASAKI	TYPE 05P0730
CHECKED 02/19/10 Y. K. I.	名称 C-IF基板
APPROVED 02/19/10 Y. K. I.	回路図
SCALE MASS	MODEL FS-2570C
	2B 04
Dwg No. C5636-K29- A	BLOCK No. 05-001-3857-0
	NAME C-IF PCB
	SCHMATIC DIAGRAM

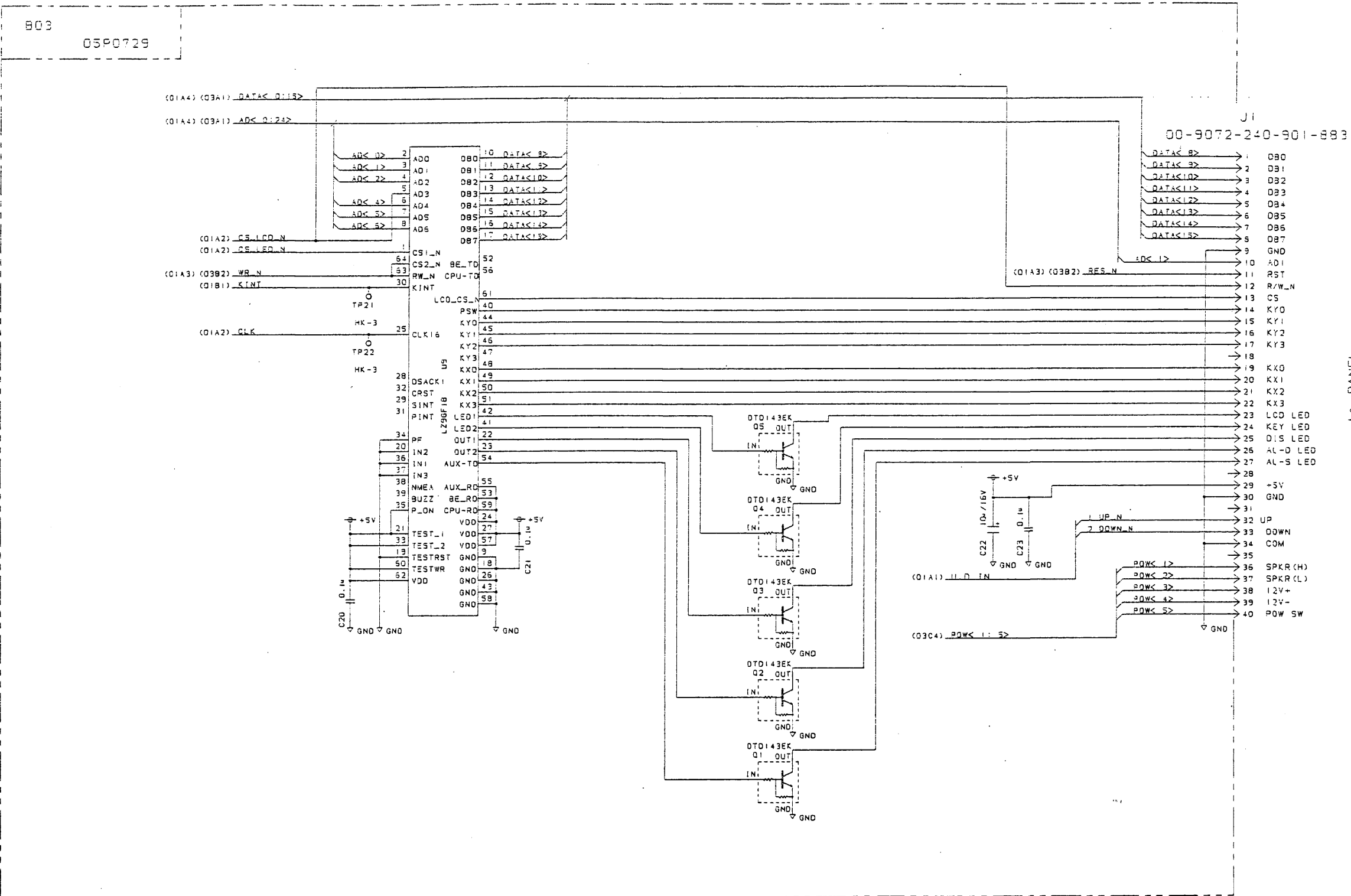

DRAWN 02/09/10 T. YAMASAKI	TYPE 05P0729 (2/3)
CHECKED 02/19/17 Y.K.	名称 C-CPU基板
APPROVED 02/19/17 Y.K.	回路図
SCALE MASS	MODEL BLOCK No.
Dwg No. C5636-K31-A	NAME C-CPU PCB
05-001-3856-0	SCHMATIC DIAGRAM

A

B

C

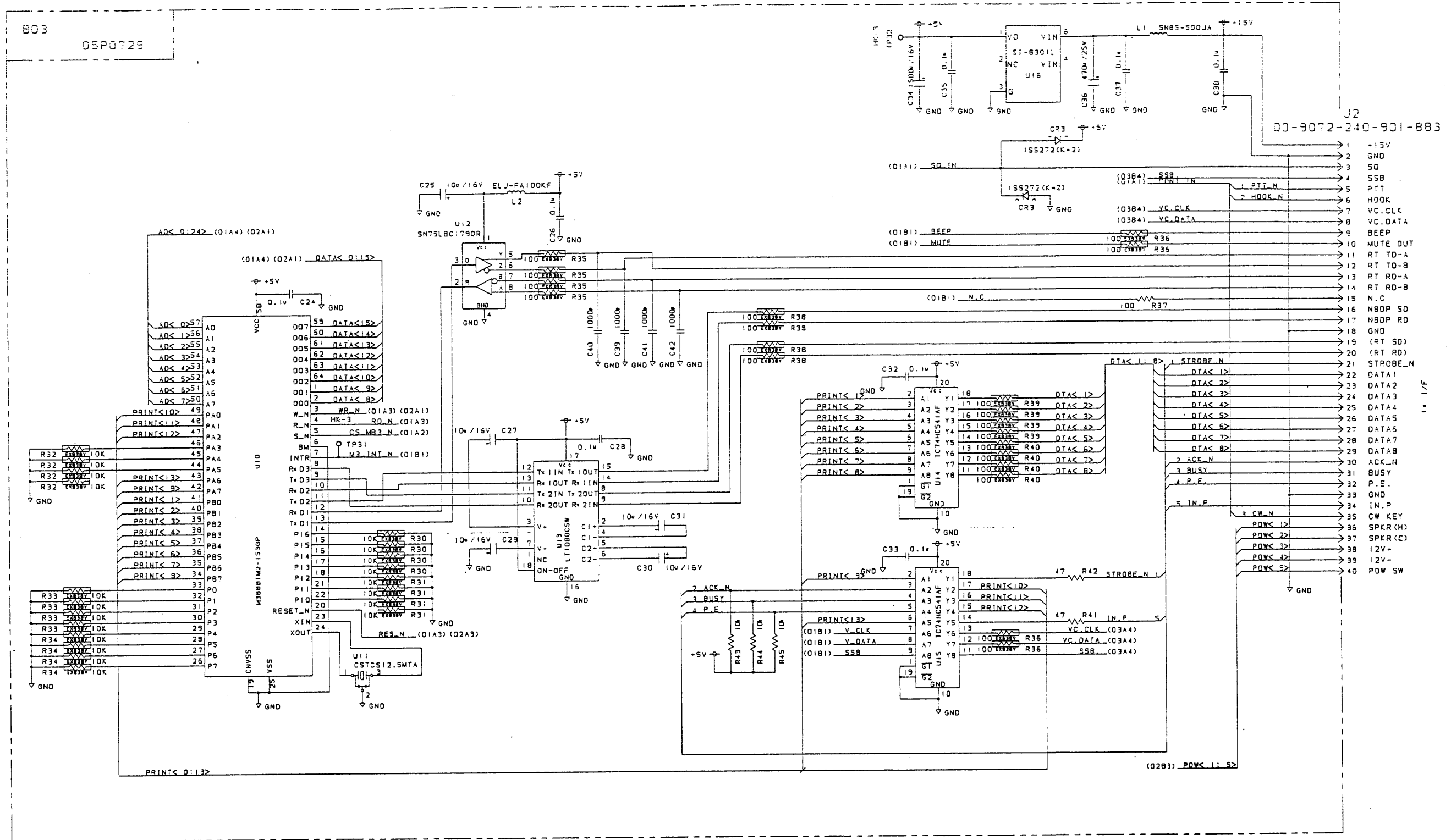

DRAWN 02/09/10 T. YAMASAKI	TYPE 05P0729 (3/3)
CHECKED 02/19/10 Y.K.	名称 C-CPU基板
APPROVED 02/19/10 Y.K.	回路図
SCALE MASS	FS-2570C 2B 03 MODEL BLOCK No. NAME C-CPU PCB
Dwg No. C5636-K32-A	05-001-3856-0 SCHEMATIC DIAGRAM

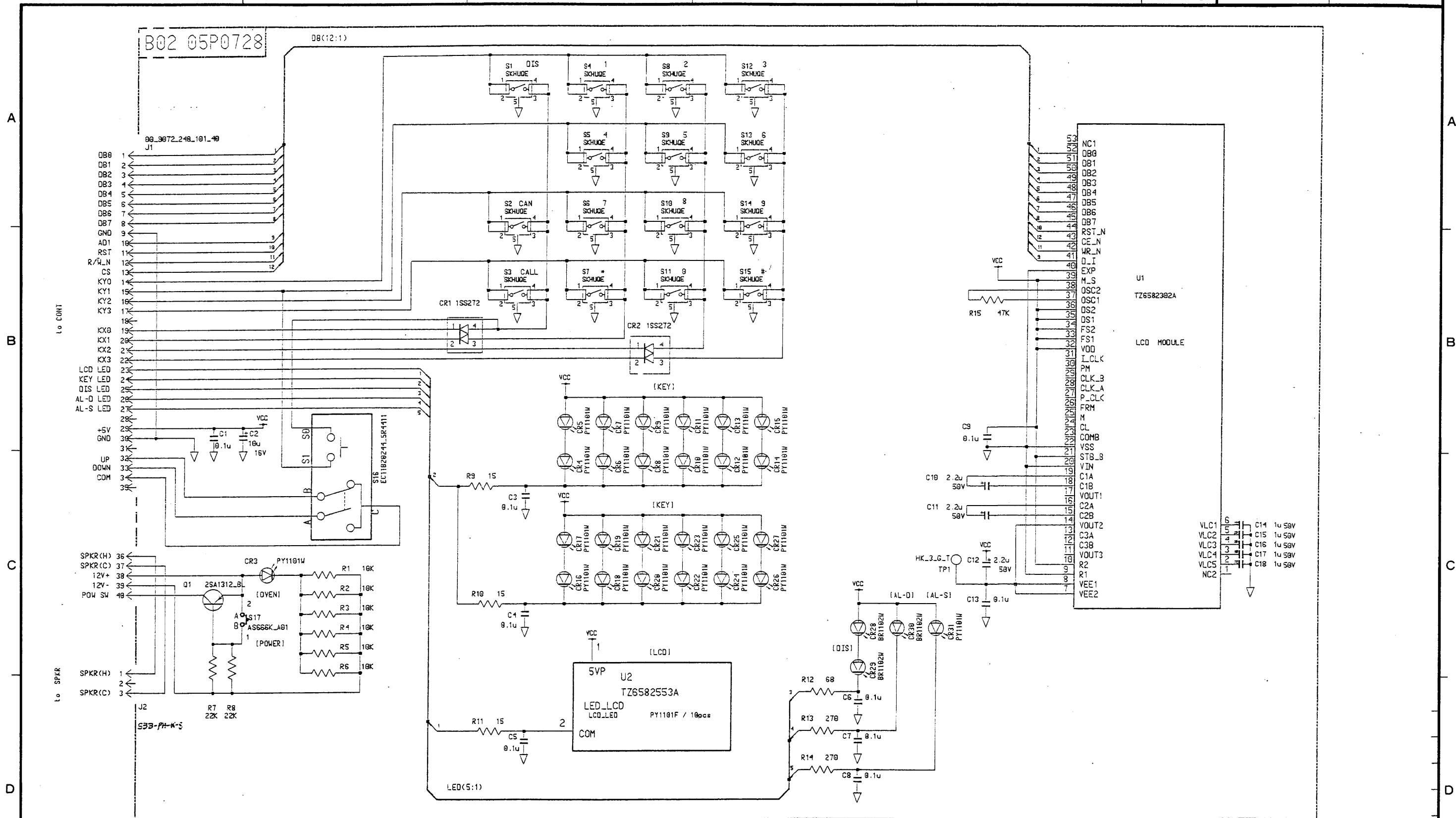

DRAWN 02/09/10 T. YAMASAKI	TYPE 05P0728
CHECKED 02/17/10 Y. K.	名称 PANEL基板
APPROVED 02/17/10 Y. K.	回路図
SCALE MASS	MODEL BLOCK No.
Dwg No. C5636-K33- A	NAME PANEL PCB
05-001-3855-2	SCHEMATIC DIAGRAM

A

B

C

D

A

B

C

D

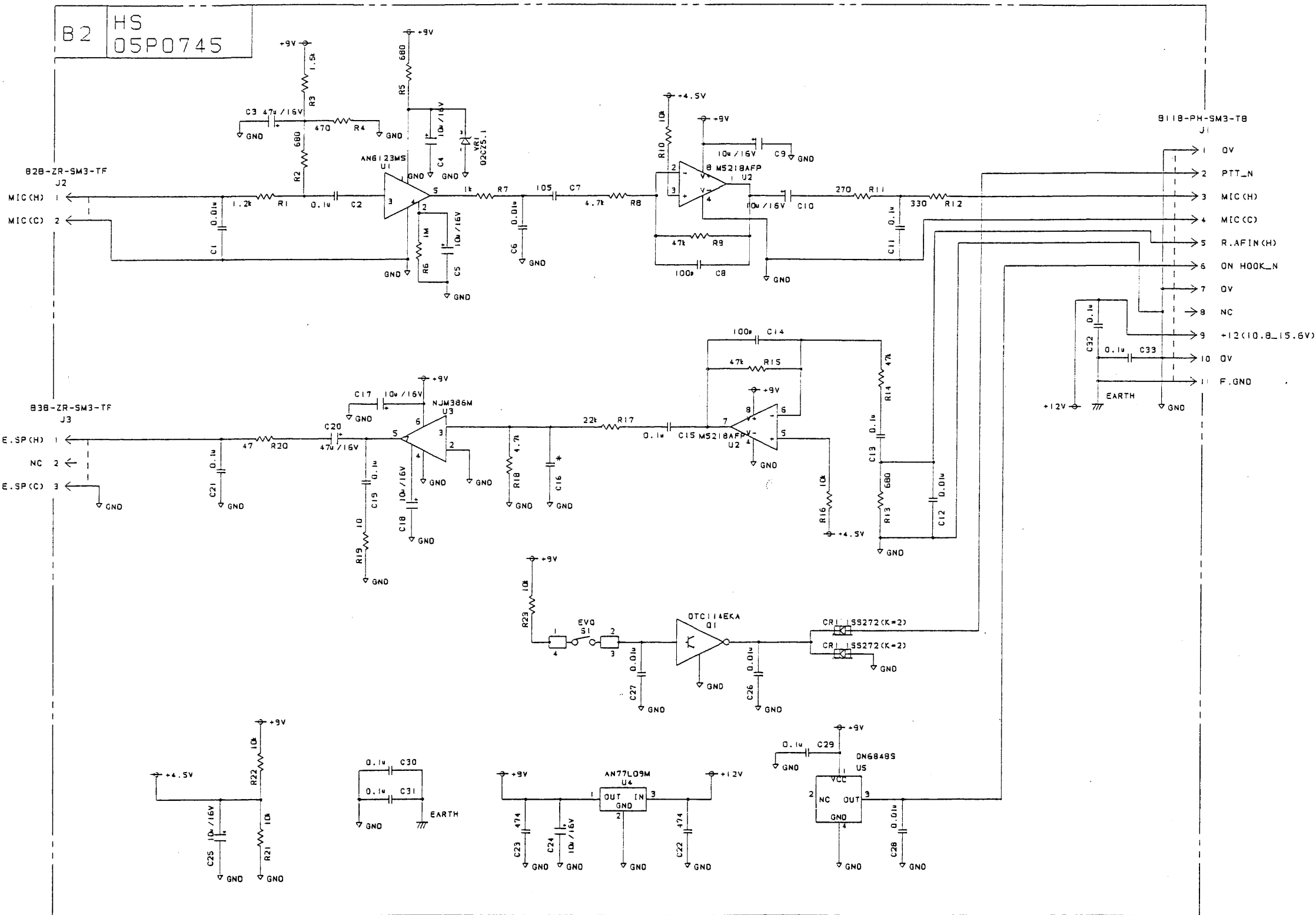

* : 実接なし
 * : PATTERN ONLY

DRAWN 02/04/26 T. YAMASAKI	TYPE 05P0745
CHECKED 02/04/26 Y.K.I.	名称 ハンドセット
APPROVED 02/04/26 Y.K.I.	回路図
SCALE MASS	MODEL BLOCK No.
Dwg No. C5636-K05- A	NAME HANDSET
05-001-3876-0	SCHEMATIC DIAGRAM

6

5

4

3

2

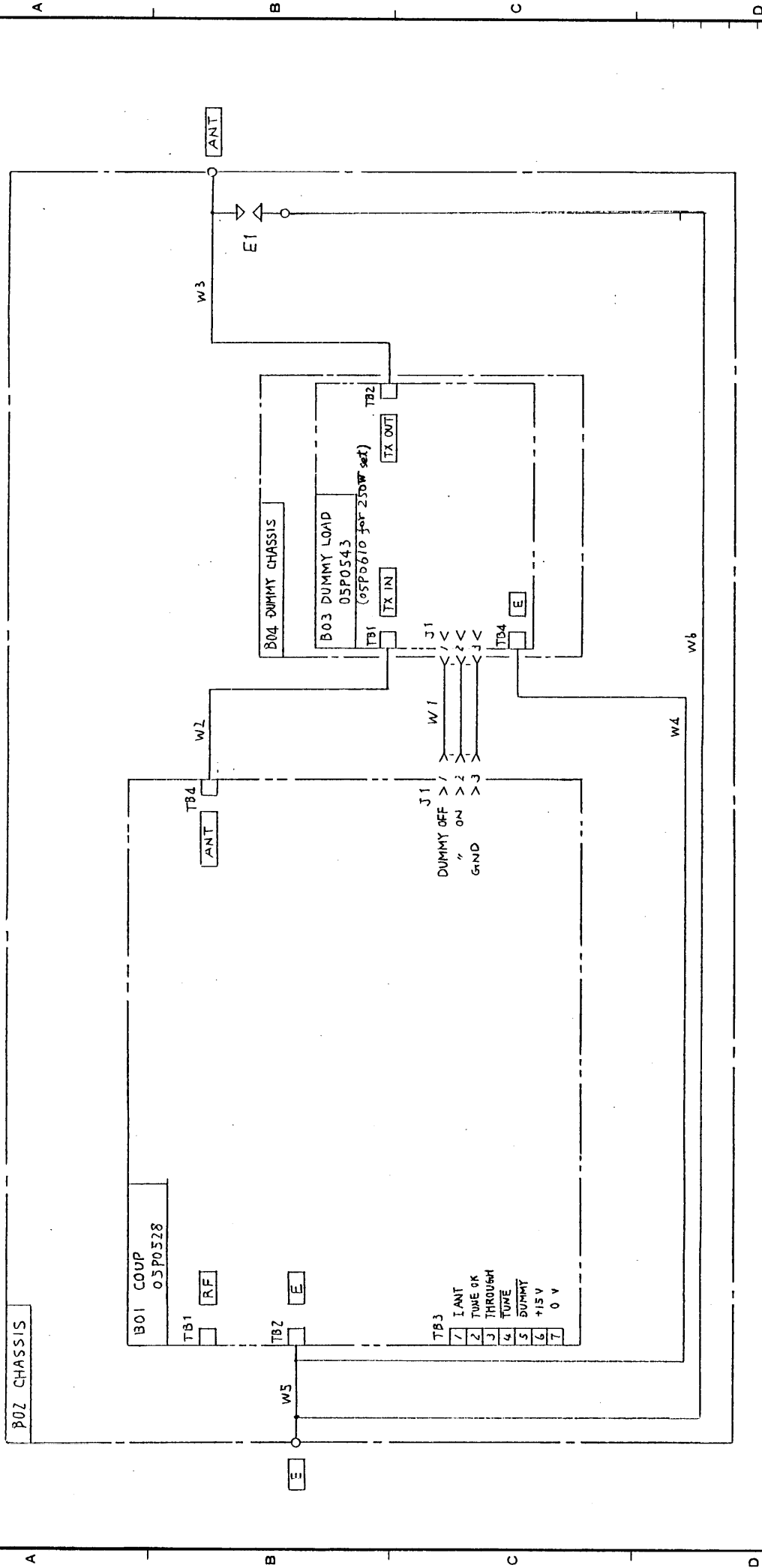

承認 APPROVED	May. 31 '93 M. KIDA	名称 TITLE	アンテナカプラー ANTENNA COUPLER
検図 CHECKED	May. 31 '93 F. SAITO	図番 DWG. NO.	2B02 AT-1560
製図 DRAWN	May. 31 '93 T. NISHIBUCHI		C5572-K03-B

FS-1562
FS-1517S/2550

5-40

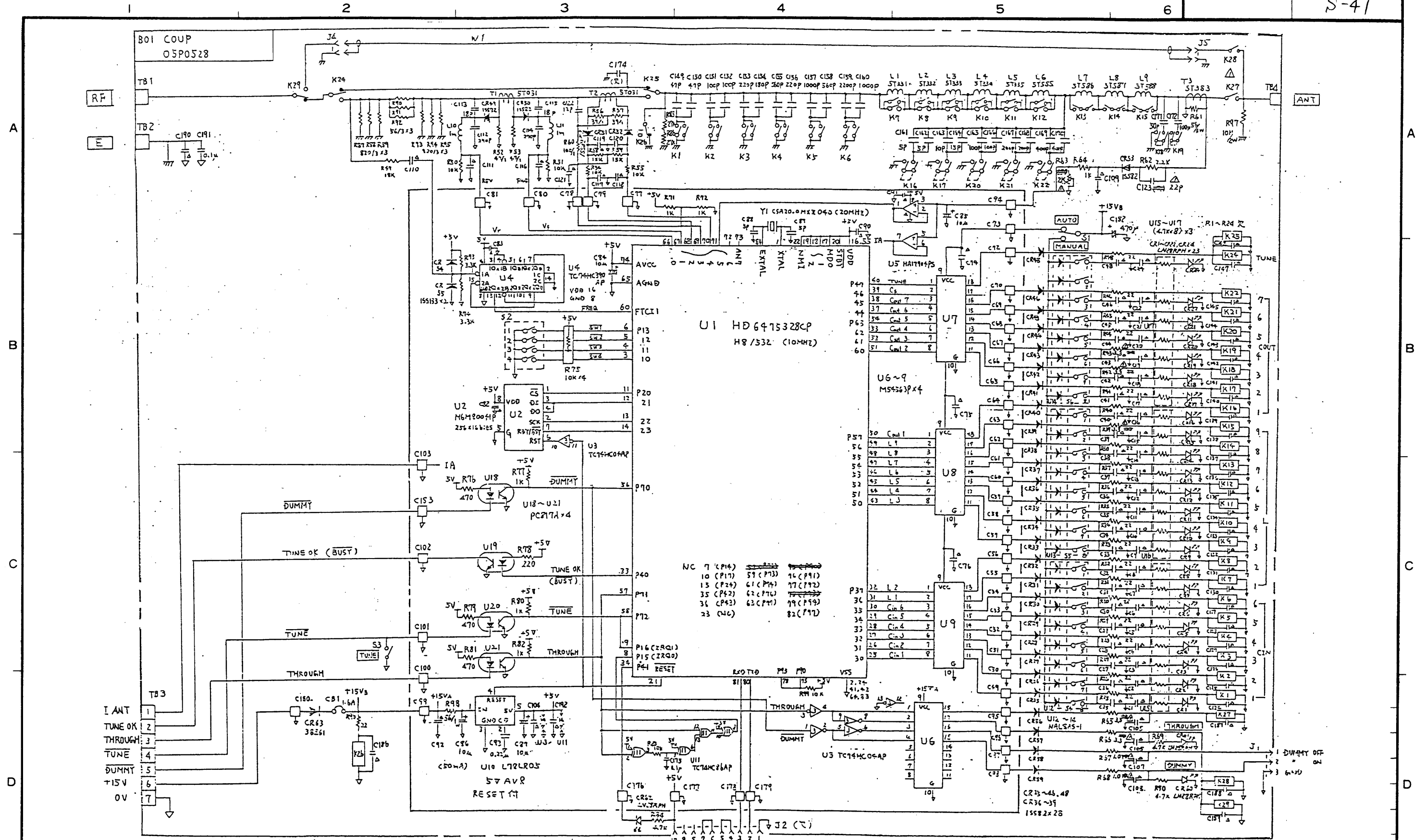

NOTE (1) RESISTORS ARE IN Ω (0.16W), CAPACITORS ARE IN F, INDUCTORS ARE IN H, UNLESS OTHERWISE NOTED.
 (2) MARKS Δ : $0.1 \mu F/25V$
 \square : $0.01 \mu F/16V$

REMARKS		TYPE	
		05P0528	
		名称 カプラー基板	
DRAWN T.Y	APPROVED MAR. 75 T. SAITO	FS-2550 FS-1575 FS-1562	NAME COUPLER BOARD
SCALE	MASS kg	APPLICABLE TO; (MODEL)	BLOCK NO. DWG NO. C5572-K01-B

A

B

C

D

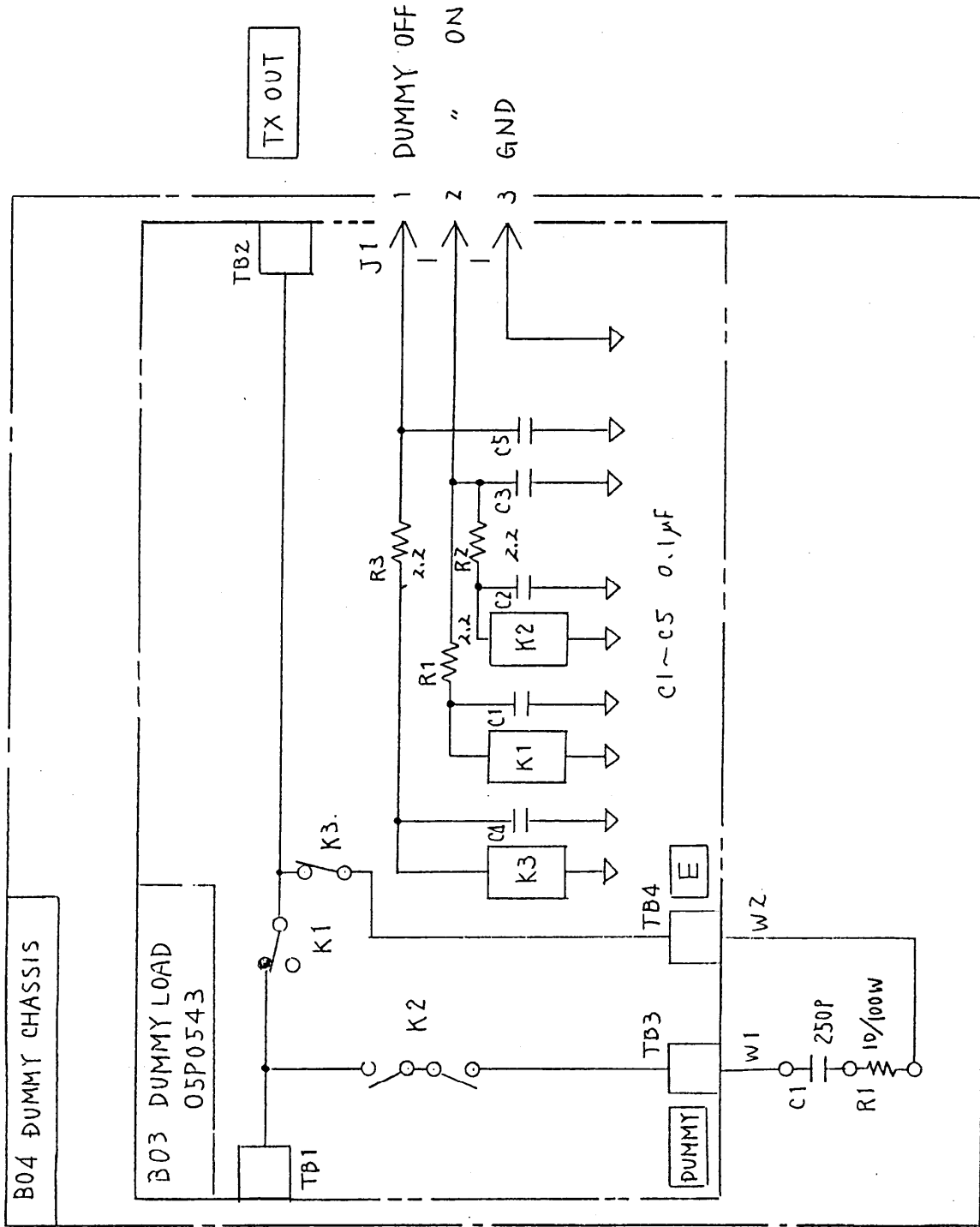

FS-1562

FS-15/75

承認 APPROVED	品番 ITEM	品名 NAME	材質 MATERIAL	数量 Q'TY	図番 DWG.NO.	摘要 REMARKS
May 31 '93 M. IKEDA		三角法 THIRD ANGLE PROJECTION				
検図 CHECKED	May 31 '93 T. SAITO	尺度 SCALE			2B03 05P0543	ダミーロード基板 DAMMY LOAD BOARD
製図 DRAWN	May 31 '93 T. NISHINO	重量 WEIGHT	kg		図番 DWG.NO. C5572-K02-A	

A

B

C

D

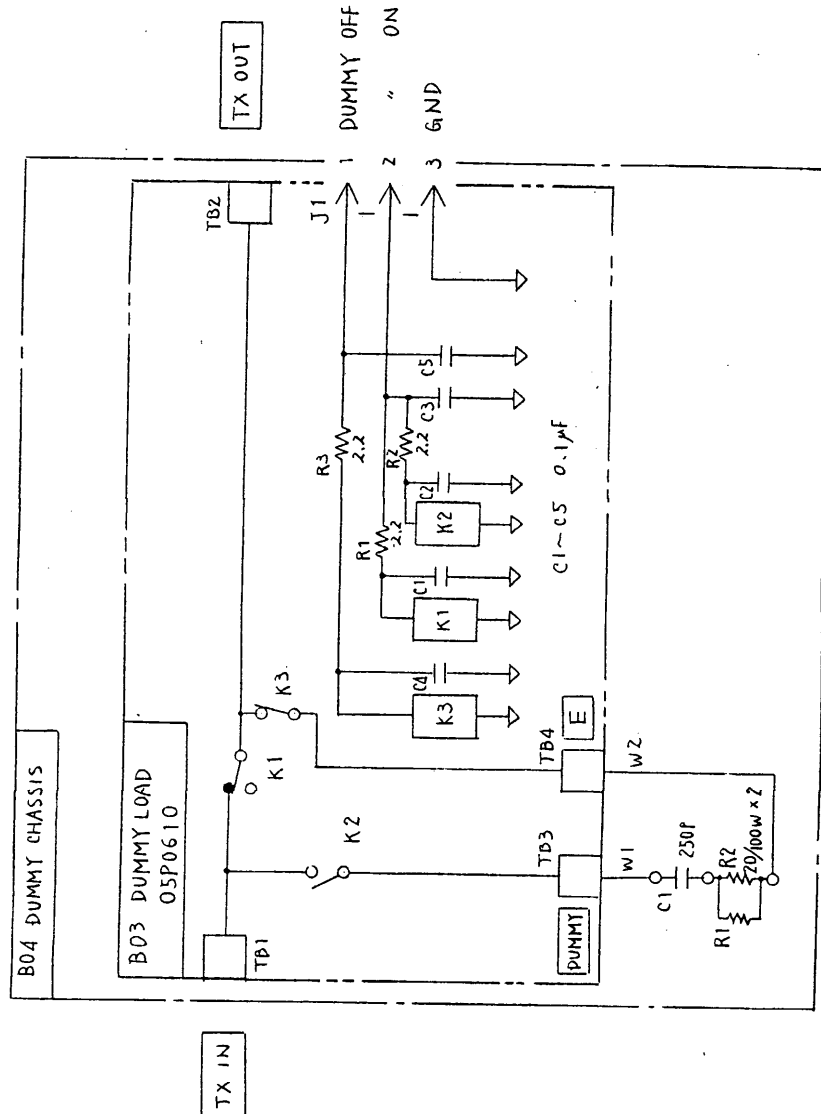

REMARKS				TYPE	05P0610
				名称	ダミーロード基板
DRAWN	APPROVED	FS-1562-25	B 4	NAME	DUMMY LOAD BOARD (250W)
T.Y	<i>July 19 64</i>		B 3	DWG NO.	C5572-K16- A
SCALE	MASS	APPLICABLE TO;	BLOCK NO.		
/	kg	(MODEL)			

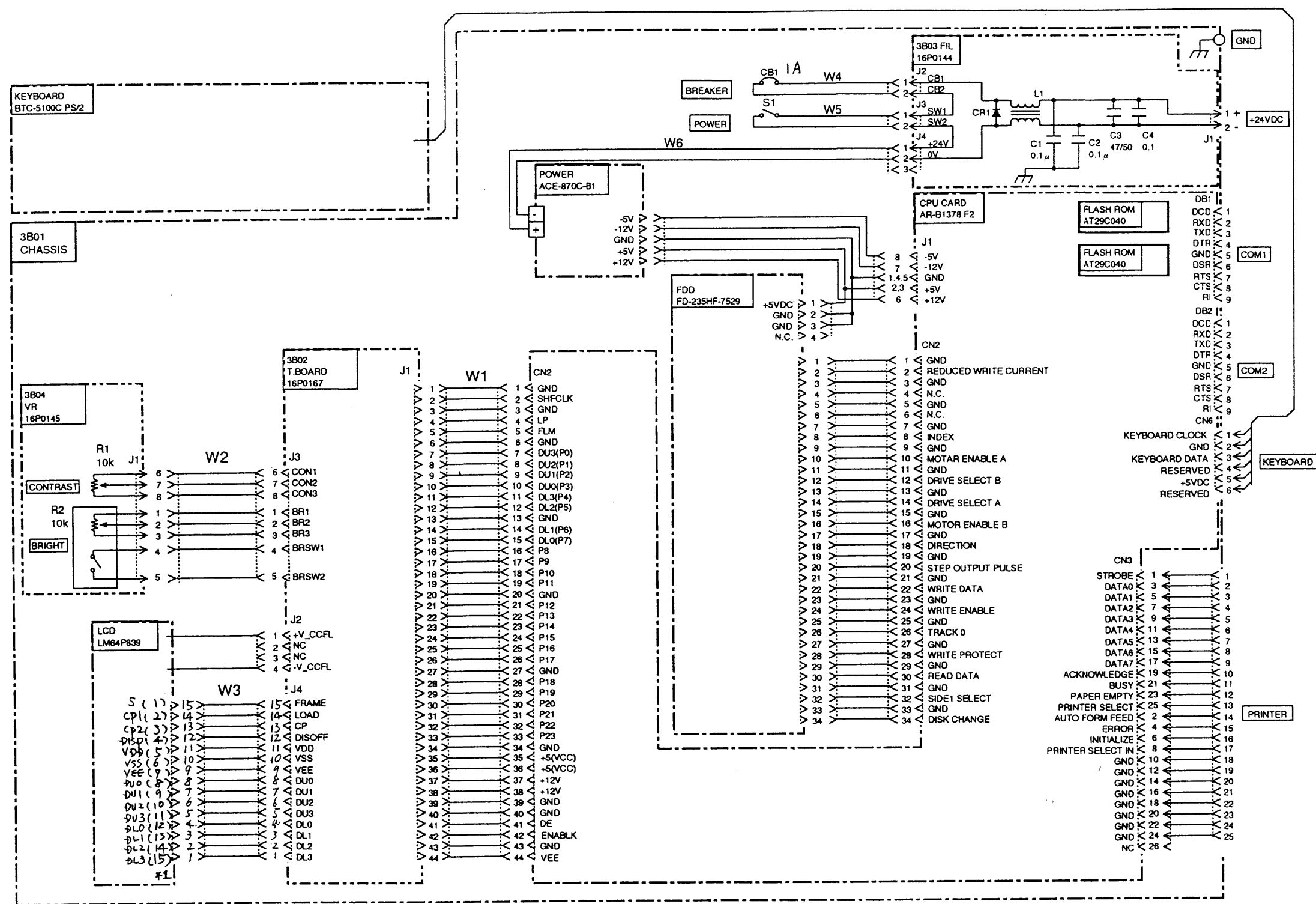

DRAWN May 6 '99 T. YAMASAKI		TYPE IB-581
CHECKED May 6 '99 K. Kusumoki		名称 ターミナルユニット
APPROVED May 6 '99 K. Kusumoki		回路図
SCALE /	MASS kg	APPLICABLE TO; (MODEL)
DWG. NO. C5609-K03-C	BLOCK NO. 16-001-3132-3	NAME TERMINAL UNIT
SCHEMATIC DIAGRAM		

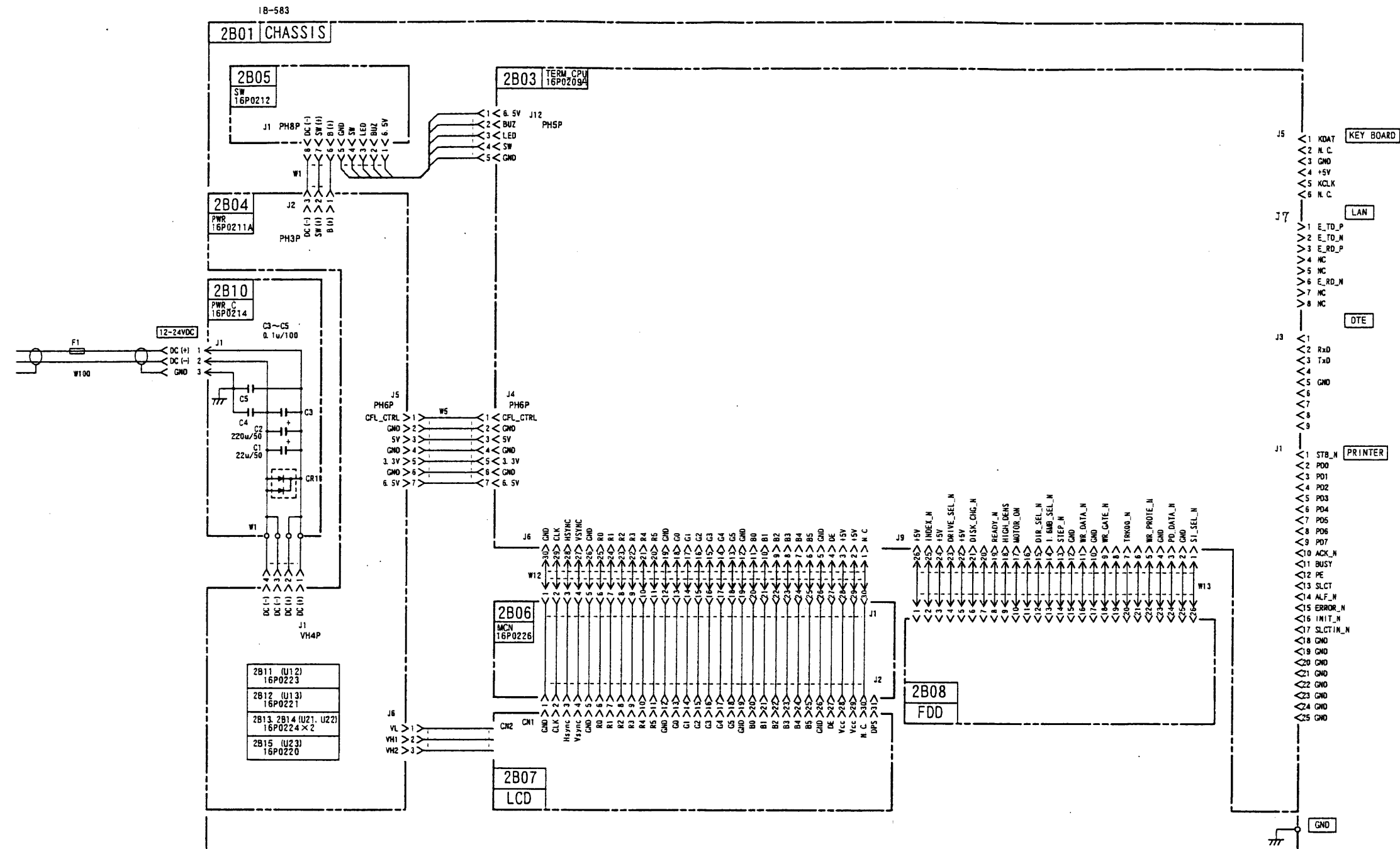

DRAWN 02/09/05 T. YAMASAKI	TYPE 1B-583
CHECKED 02/15/05 Y. Kikuchi	名称 ターミナル部
APPROVED 02/19/05 Y. Kikuchi	回路図
SCALE MASS	MODEL BLOCK No.
Dwg No. C5636-K06- A	NAME TERMINAL UNIT
16-001-3219-0	SCHEMATIC DIAGRAM

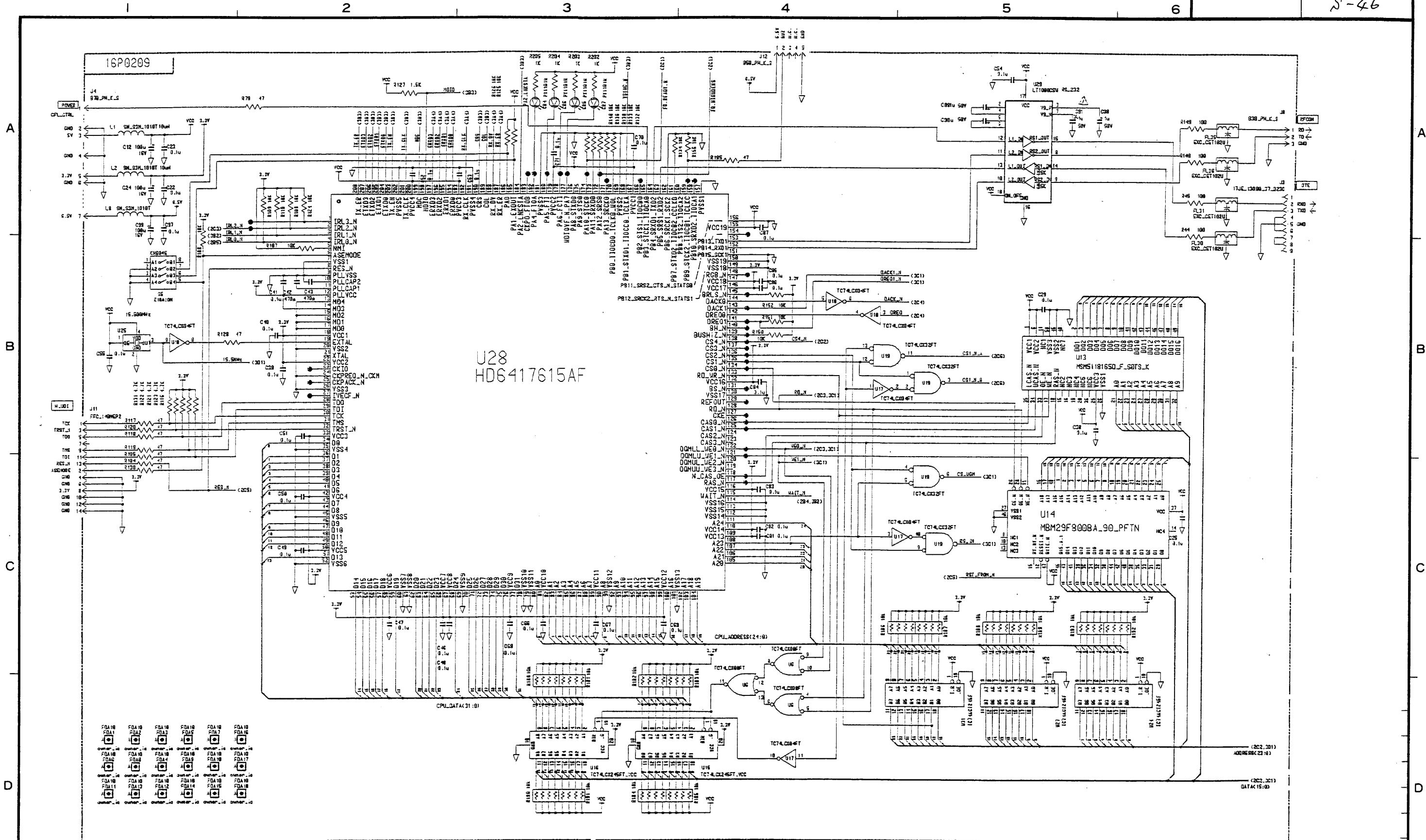

DRAWN 02/09/10 T. YAMASAKI	TYPE 16P0209 (1/3)
CHECKED 02/09/10 Y.K.I.	名称 TERM_CPU基板
APPROVED 02/09/10 Y.K.I.	回路図
SCALE MASS	MODEL IB-583
Dwg No. C5636-K34- A	BLOCK No. 16-001-3198-1
	NAME TERM_CPU PCB
	SCHMATIC DIAGRAM

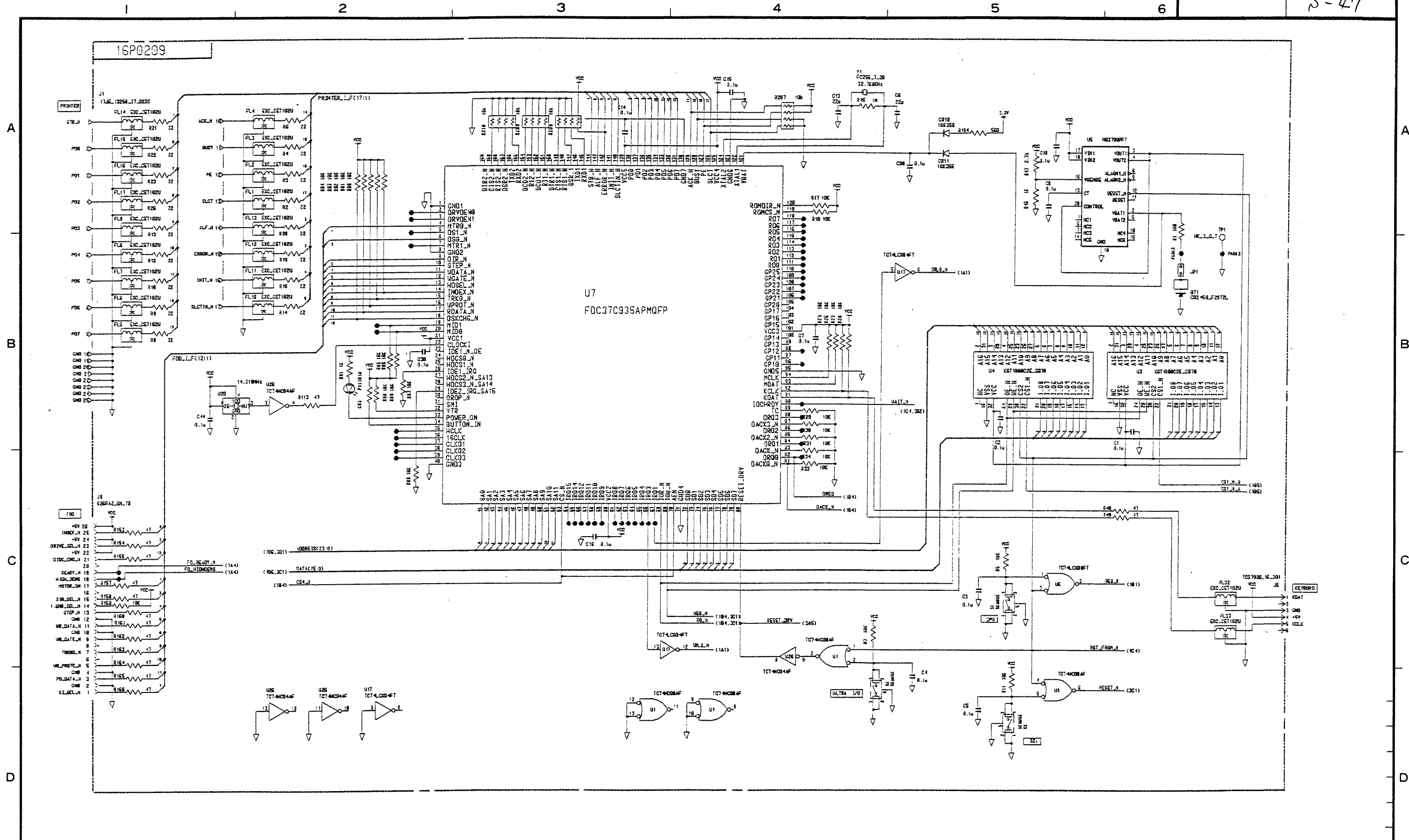

DRAWN 02/09/10 T. YAMASAKI	TYPE 16P0209 (2/3)
CHECKED 02/09/10 Y.K.	名称 TERM_CPU基板
APPROVED 02/09/10 Y.K.	回路図
SCALE MASS	MODEL IB-583
Dwg No. C5636-K35- A	BLOCK No. NAME TERM_CPU PCB
	16-001-3198-0
	SCHEMATIC DIAGRAM

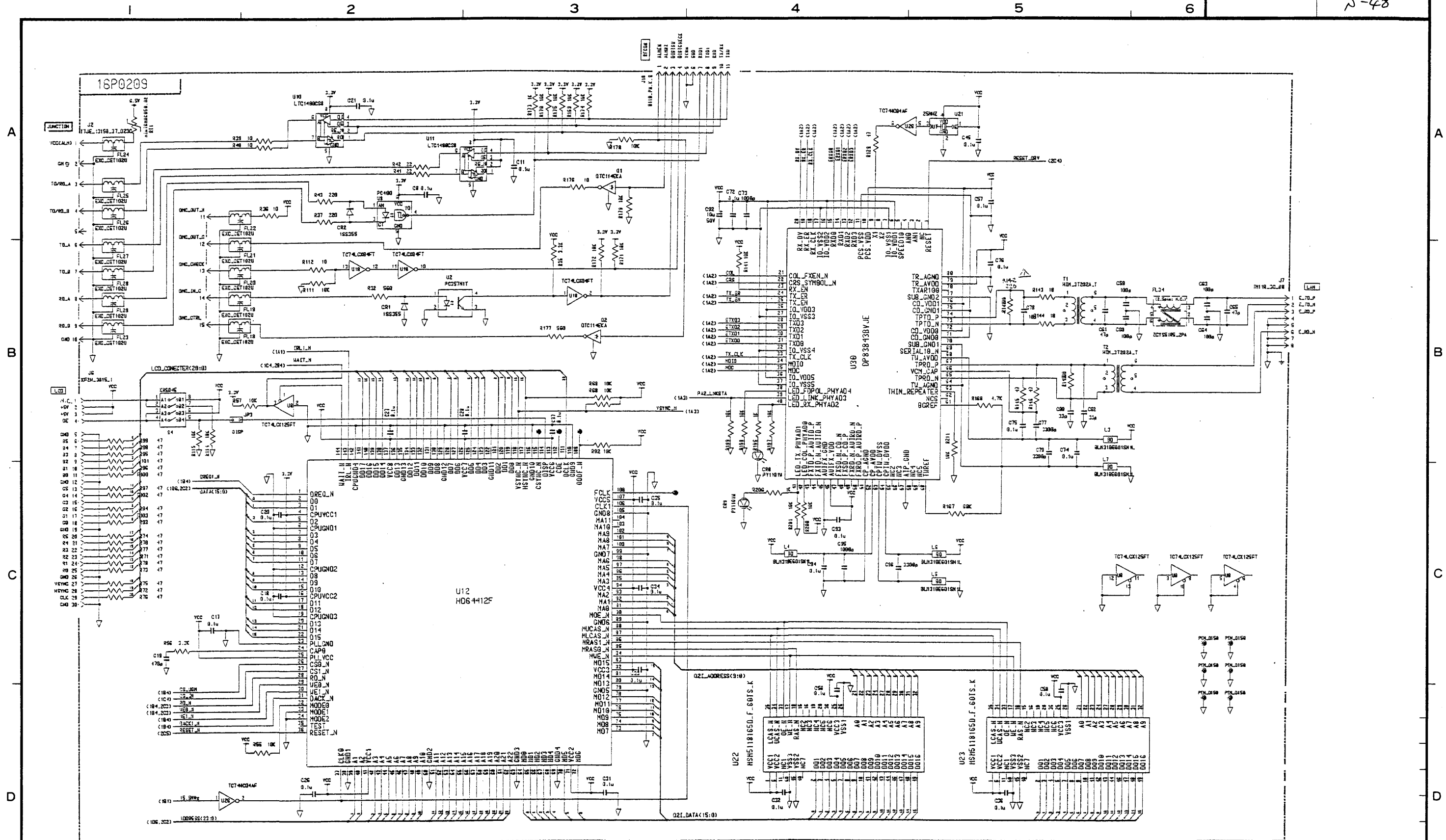

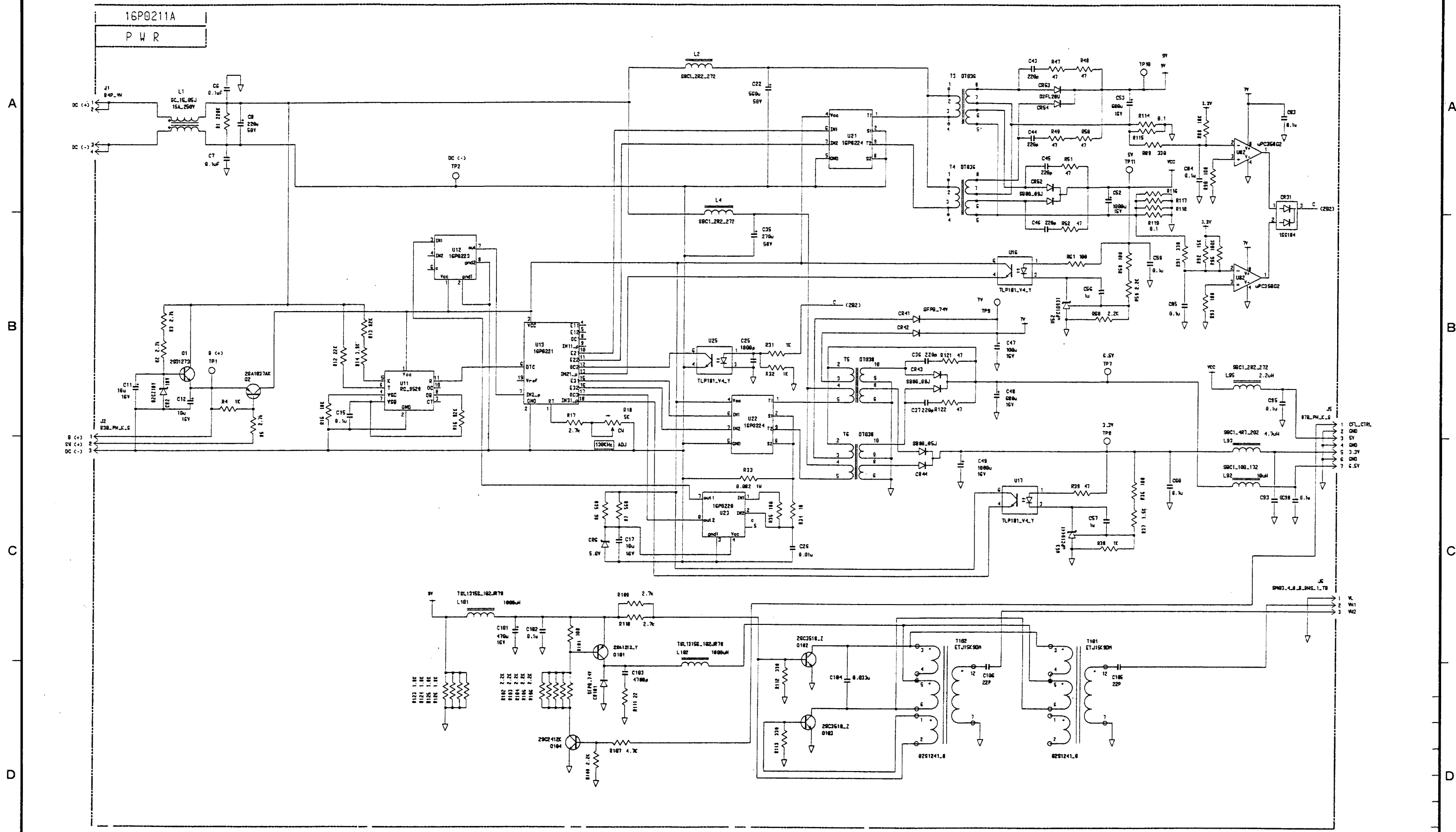

DRAWN 02/09/05 T. YAMASAKI	TYPE 16P0211A
CHECKED 02/09/05 Y.K.	名称 PWR基板
APPROVED 02/09/05 Y.K.	IB-583 回路図
SCALE MASS	MODEL BLOCK No.
Dwg No. C5636-K07-A	NAME PWR PCB
16-001-3220-0	SCHMATIC DIAGRAM

4

3

2

7

8

5

4

3

2

1

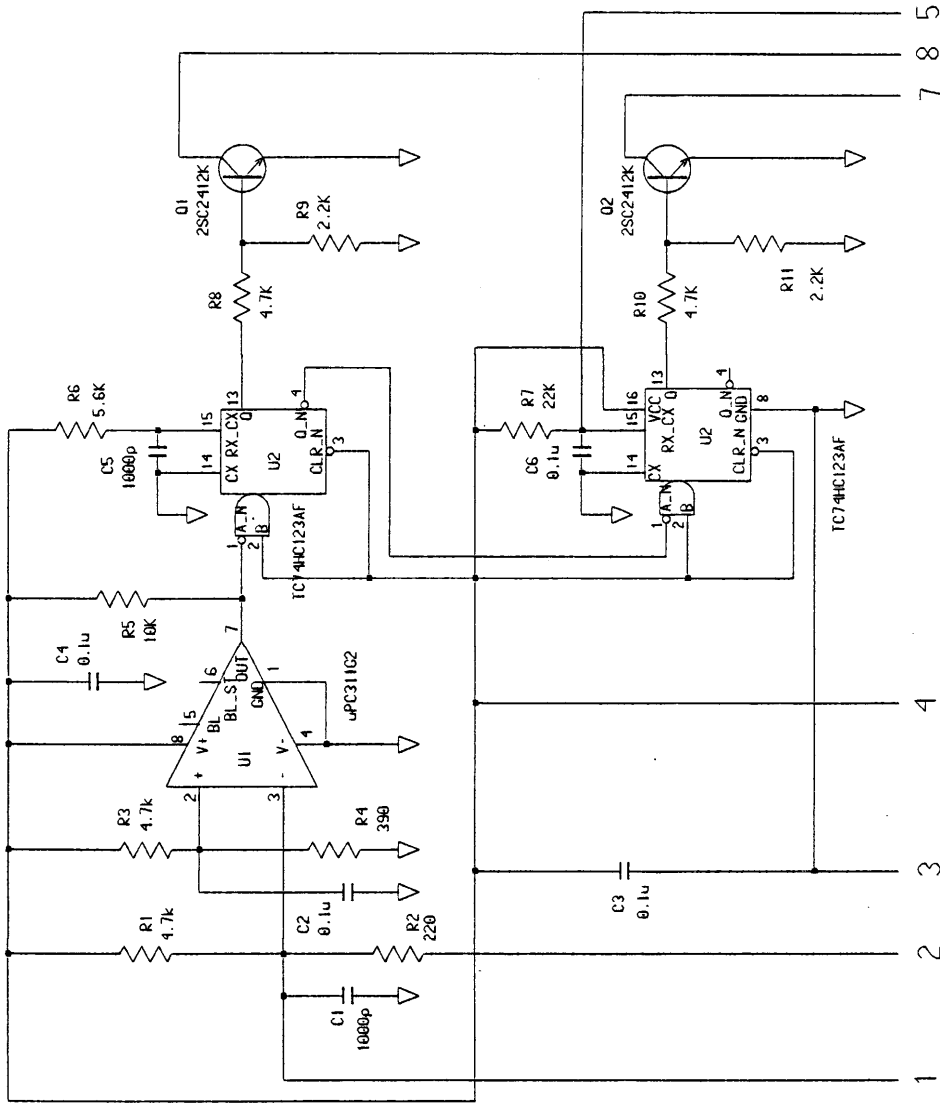

DRAWN	T. YAMASAKI	TYPE	16P0220
CHECKED	<i>Y. K.</i>	名称	PWR HIC基板
APPROVED	<i>Y. K.</i>	回路図	
SCALE	1/1	MODEL	IB-583
DWG No.	C5636-K37-A	BLOCK No.	
		NAME	PWR HIC PCB
			SCHEMATIC DIAGRAM

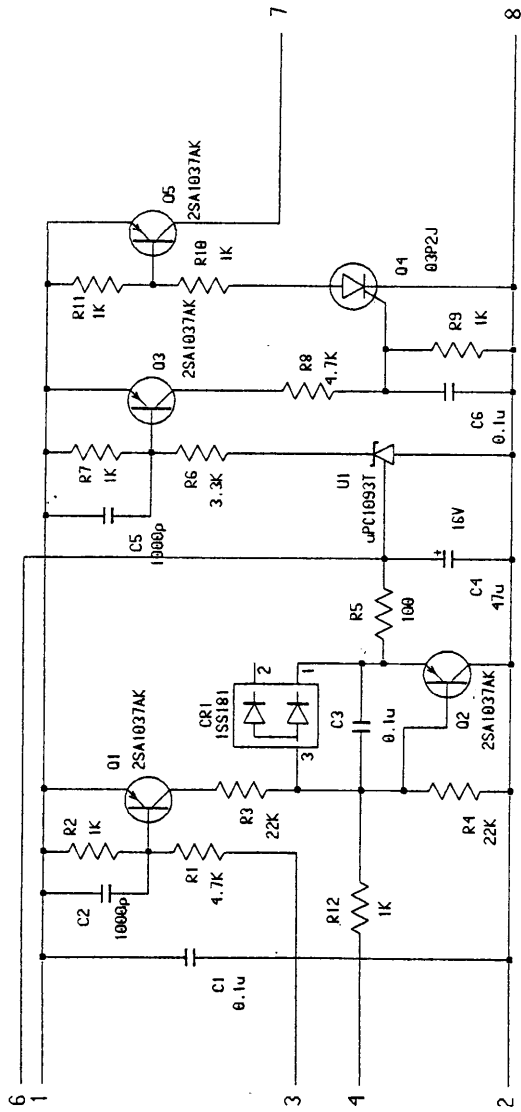

DRAWN 02/09/10 T. YAMASAKI	TYPE 16P0223
CHECKED 02/19/19 Y.K.	名称 PWR HIC基板
APPROVED 02/19/19 Y.K.	回路図
SCALE MASS	MODEL IB-583
DWG No. C5636-K39-A	NAME PWR HIC PCB
	BLOCK No.
	16-001-3215-0
	SCHEMATIC DIAGRAM

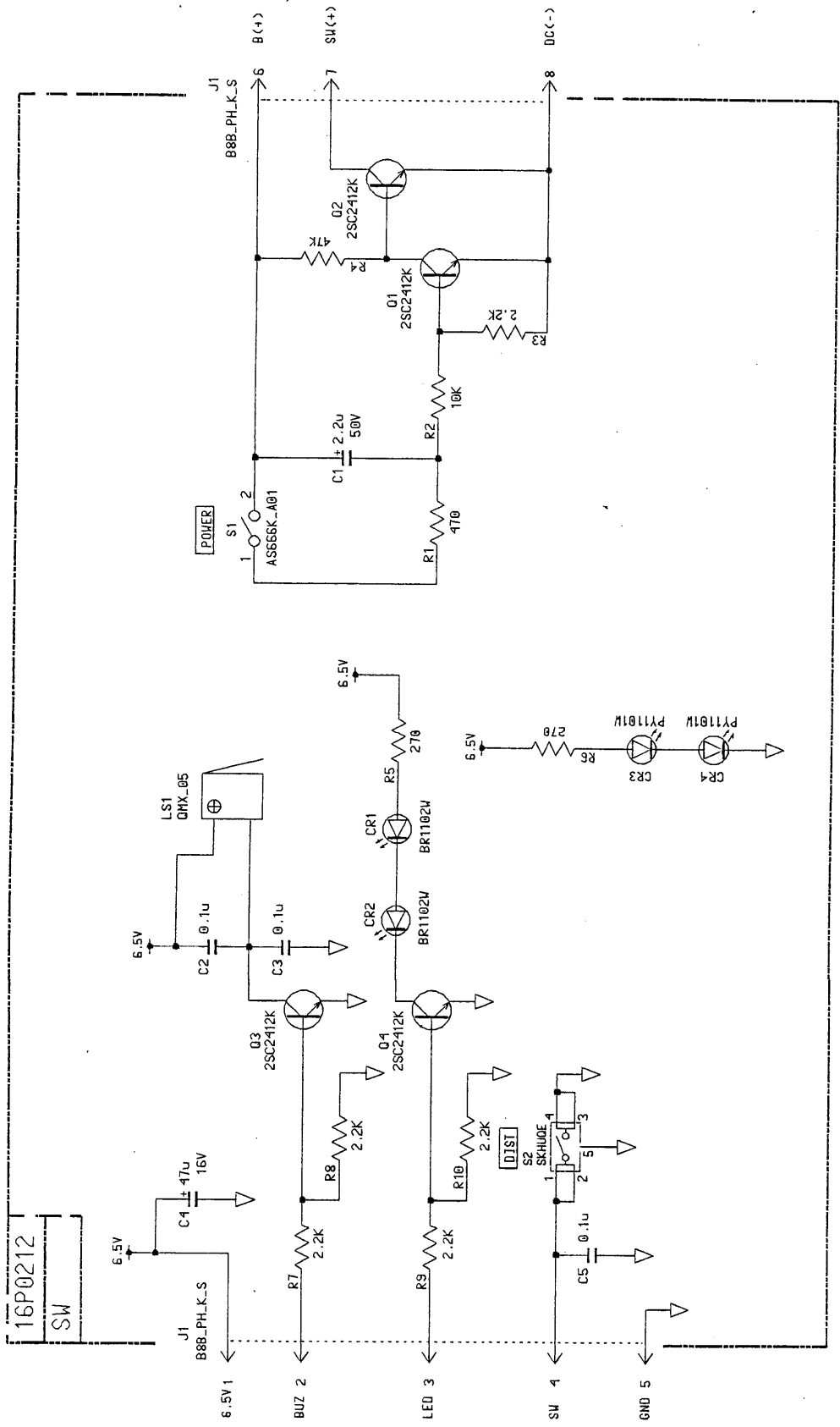

DRAWN	02/10/17	T. YAMASAKI	TYPE	16P0212
CHECKED	02/10/17	Y. Kishida	名称	SW基板
APPROVED	02/10/17	Y. Kishida	回路図	
SCALE	MASS		NAME	SW PCB
Dwg No.	C5635-K13-A		BLOCK No.	
			MODEL	IC-215
				16-001-3200-0
				SCHEMATIC DIAGRAM

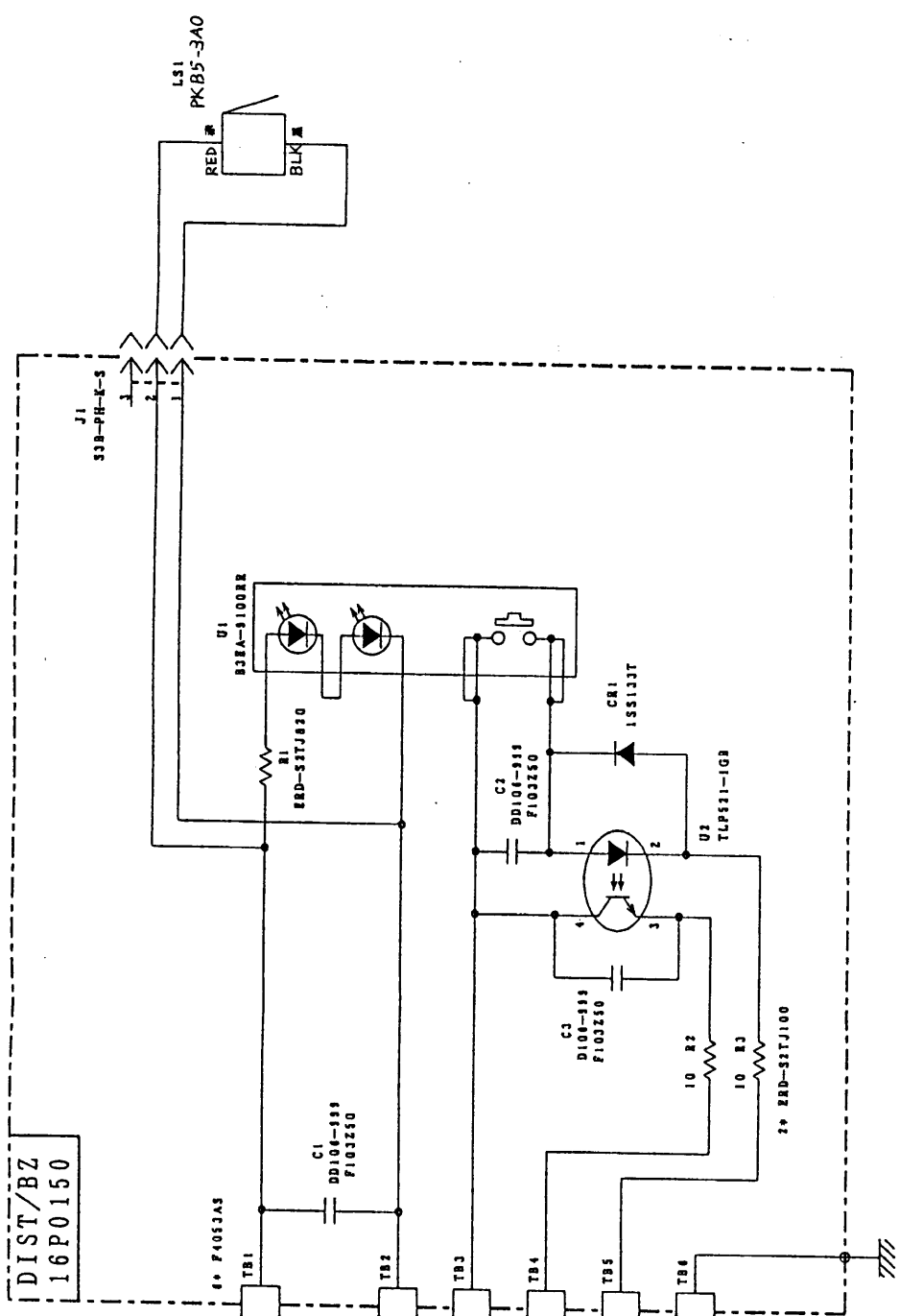

DRAWN <i>Dec 9 '99 Yamamoto</i>	TYPE IC-302/IC-303
CHECKED <i>Dec 9 '99 Kusunoki</i>	名称 遭難警報発呼器/着信指示器
APPROVED <i>Dec 9 '99 Kusunoki</i>	回路図
SCALE /	NAME DIST.ALART/ DIST.RECEIV.UNIT
MASS kg	BLOCK NO.
DWG NO. C5613-K04-C	16-001-3153-1
SCHEMATIC DIAGRAM	

FURUNO ELECTRIC CO., LTD.

A

B

C

D

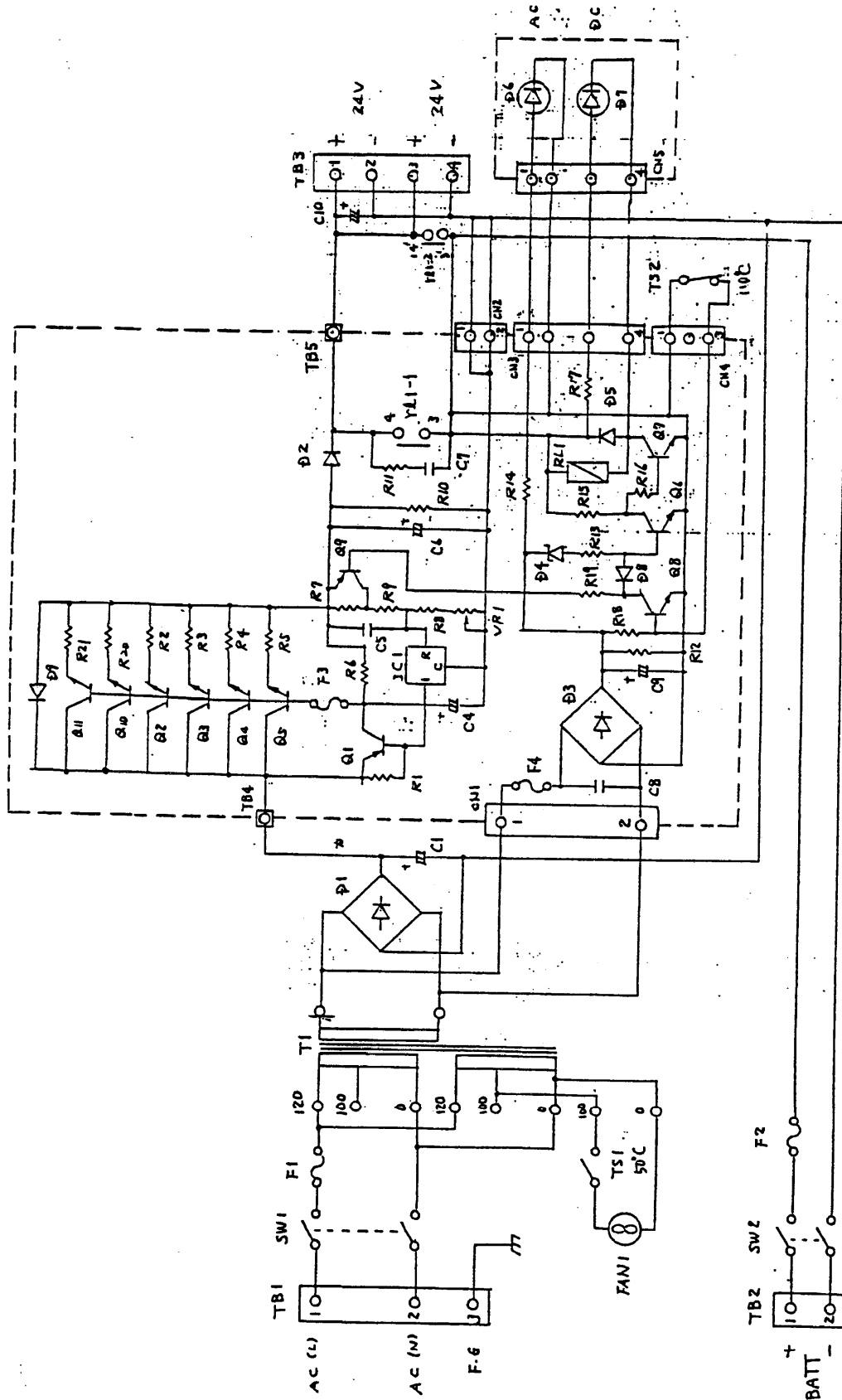

DRAWN Dec. 21, '95 S. Yamashita				TYPE	PR-300
CHECKED Dec. 21, '95 K. Kusunoki		RC15001T		名称	AC-DC電源ユニット
APPROVED Dec 21 '95 K. Ota		FS-75			
		FS-15			
		FS1562-15		回路図	
SCALE	MASS 14.5 kg	APPLICABLE TO: (MODEL)	BLOCK NO.	NAME	AC-DC POWER SUPPLY UNIT
DWG NO.	C5572-K17- A	3P-M1-0990A			SCHEMATIC DIAGRAM

A
B
C
D

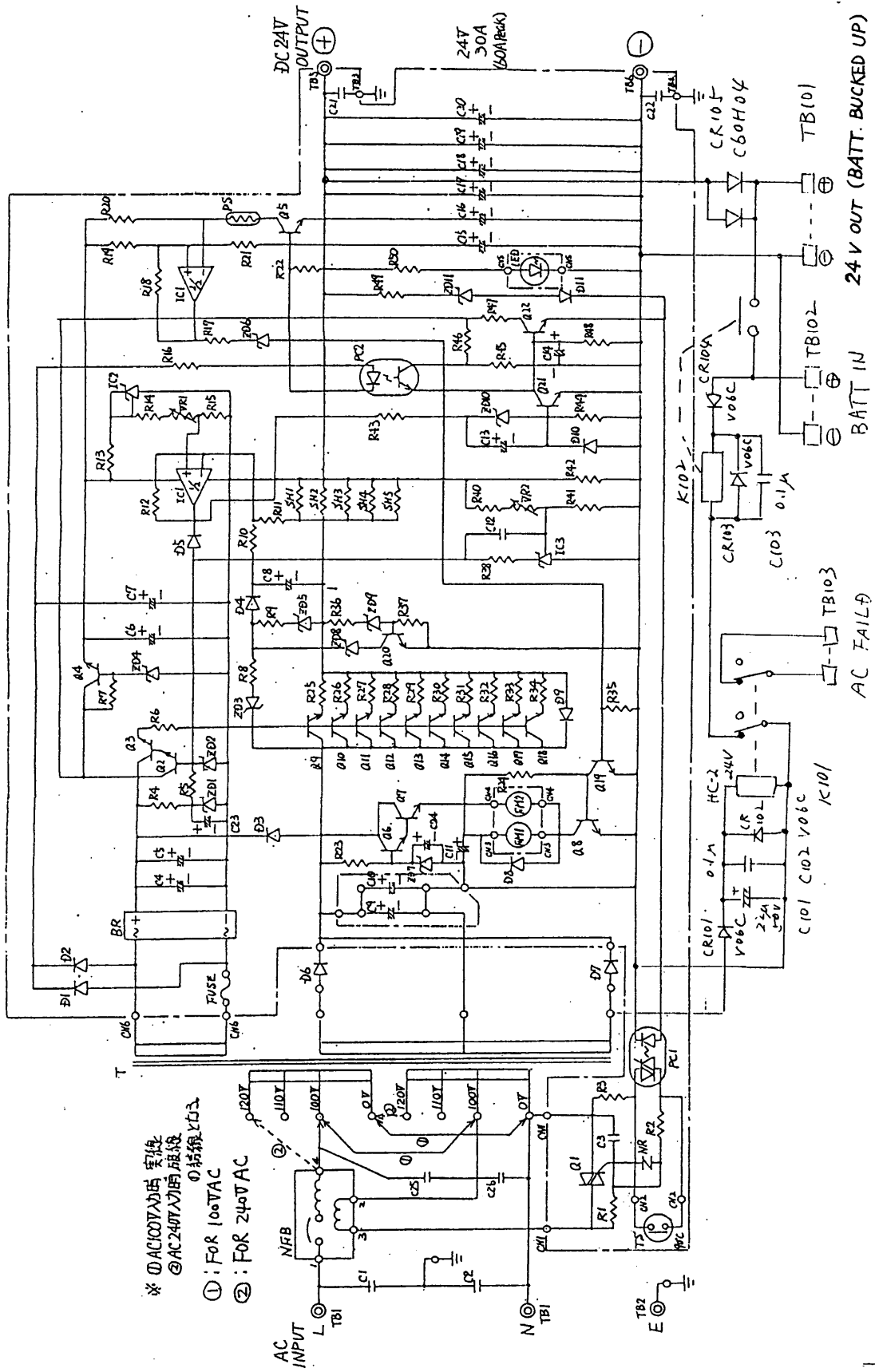

※ ① AC100V用 実線
 ② AC240V用 点線
 ③ 接続点
 ① : FOR 100VAC
 ② : FOR 240VAC

REMARKS		TYPE	
		PR850A	
		名称 AC電源ユニット	
DRAWN T.Y.	APPROVED July 15 1977 KED	NAME AC POWER UNIT	
SCALE	MASS kg	APPLICABLE TO: (MODEL)	BLOCK NO.
		DWC NO. C5519-K24- A	

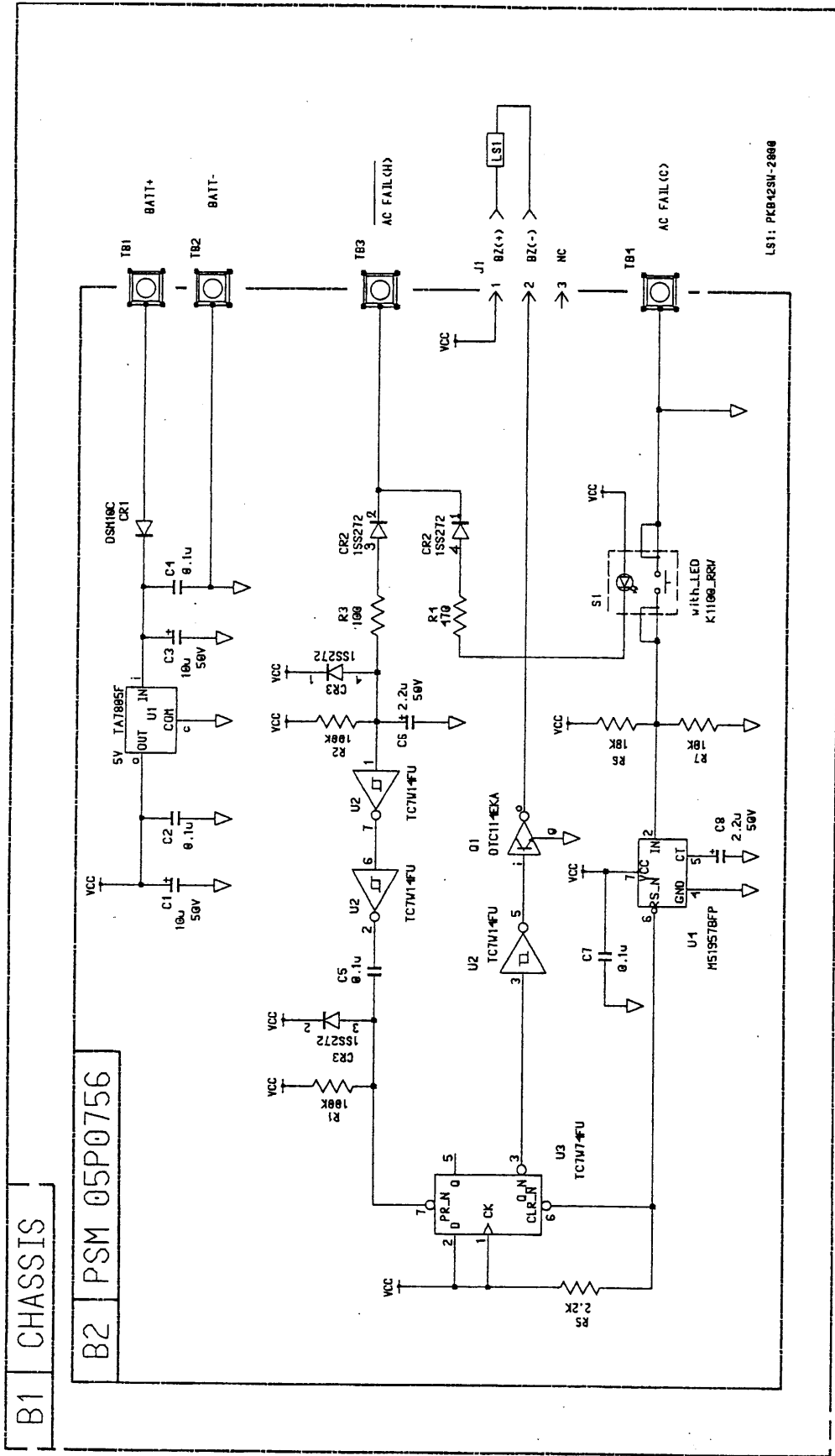

LS1: PKB425N-2668

DRAWN	T. YAMASAKI	TYPE	PSM-01
CHECKED	02/09/17	名称	パワーステータスマニター
APPROVED	02/09/17	回路図	
SCALE	02/09/17	MODEL	FS-1570/2570
	MASS	BLOCK No.	
DWG No.	C5636-K41-A	NAME	POWER STATUS MONITOR
			SCHEMATIC DIAGRAM

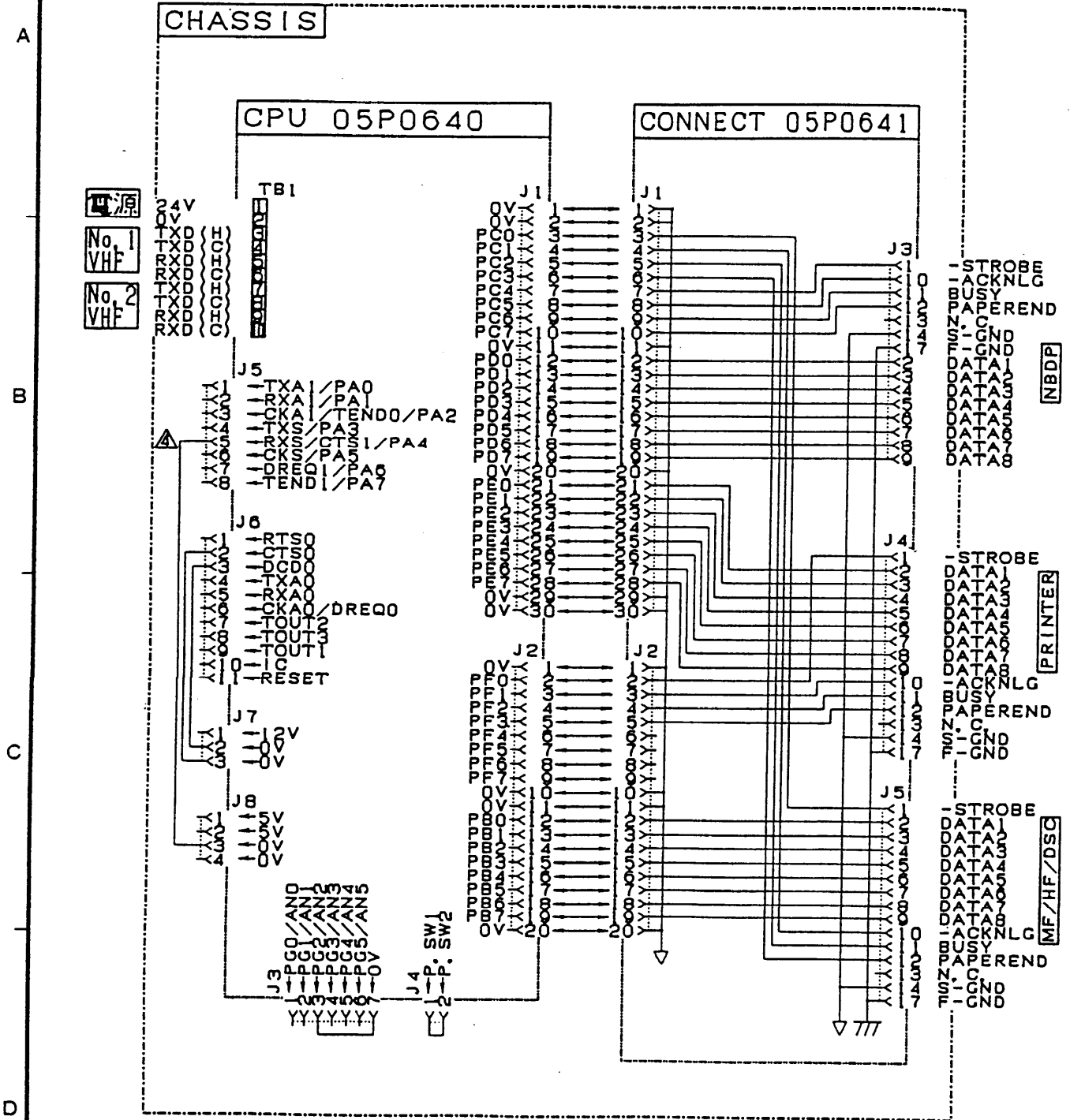

DRAWN <i>N. Yokojo Jan 22 '98</i>		TYPE	IF-8500
CHECKED <i>Jan 22 '98 K. Okamoto</i>		名称	インターフェース (総合)
APPROVED <i>Jan 22 '98 H. Yamaguchi</i>	FM-8500	回路図	
SCALE MASS kg	APPLICABLE TO; (MODEL)	BLOCK NO.	NAME INTERFACE (GENERAL)
DWG NO. C5603-K10- B			SCHMATIC DIAGRAM

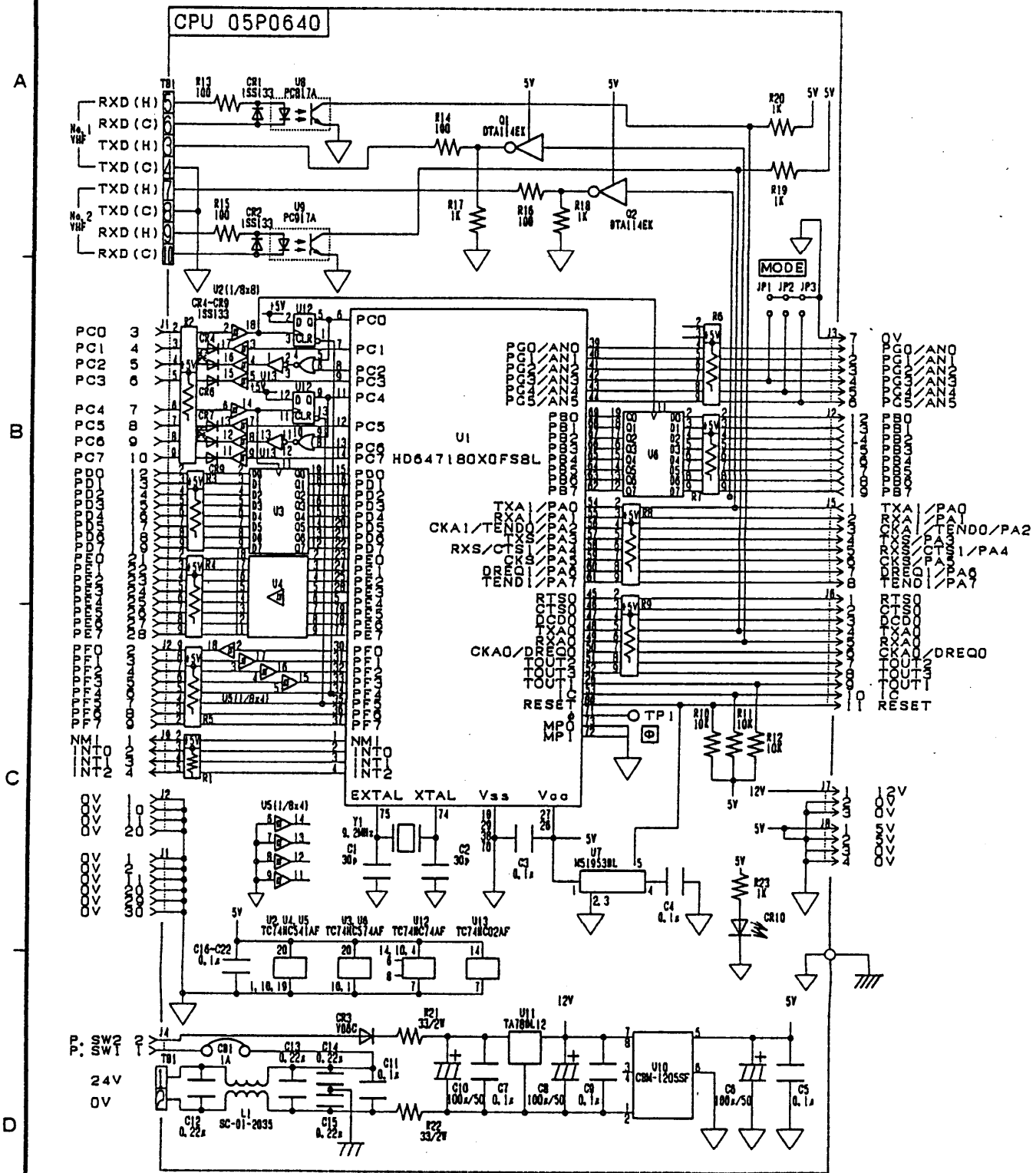

DRAWN <i>N. Yodaoka Jan. 22, '98</i>		TYPE 05P0640	
CHECKED <i>Jan. 22, '98 K. Okamoto</i>		名称 CPU基板 (オプション)	
APPROVED <i>Jan. 22, '98 G. Yamaguchi</i>		回路図	
SCALE	MASS kg	IF-8500 APPLICABLE TO; (MODEL)	1B BLOCK NO.
DWG. NO. C5603-K11- B		NAME CPU BOARD (OPTION)	
SCHEMATIC DIAGRAM			

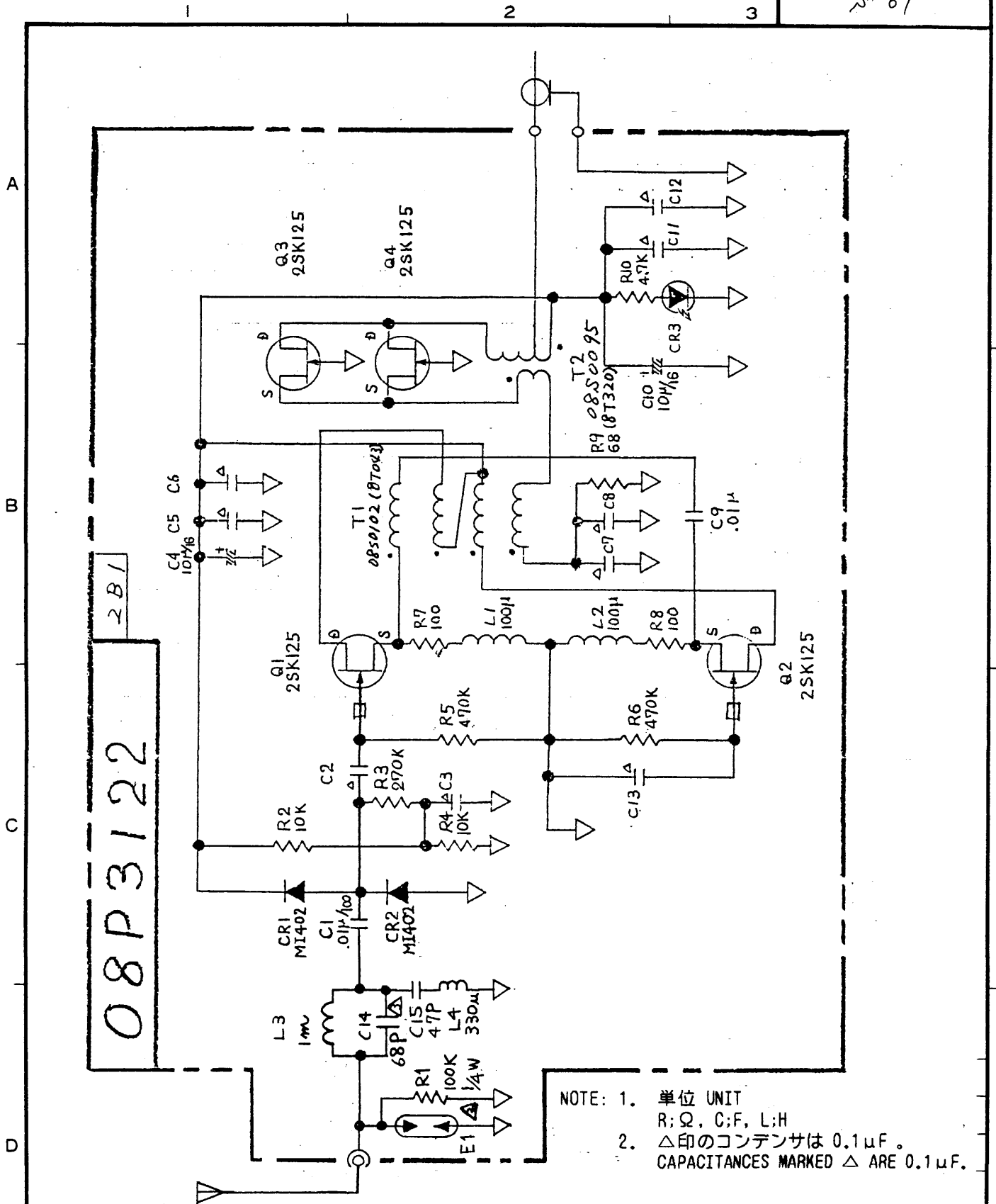

NOTE: 1. 単位 UNIT
R: Ω, C: F, L: H
2. △印のコンデンサは 0.1 μF。
CAPACITANCES MARKED △ ARE 0.1 μF.

FAX-208/288MKII/214/
210/215

オプション OPTION

品番 ITEM	品名 NAME	材質 MATERIAL	数量 Q'TY	図番 DWG.NO.	摘要 REMARKS
承認 APPROVED	三角法 THIRD ANGLE PROJECTION	名称 TITLE	2B01		
検図 CHECKED	尺度 SCALE	08P3122	プリアンプ基板 PRE-AMPLIFIER BOARD		
製図 DRAWN	重量 WEIGHT	kg	図番 DWG.NO.	C6246-005-D	