



ADVANCED MANUAL

VHF TRANSCEIVER
IC-G86

INTRODUCTION

1 ACCESSORIES

2 BATTERY CHARGE

3 ADVANCED OPERATION

4 REPEATER OPERATION

5 SCAN OPERATION

6 TONE SQUELCH AND POCKET BEEP

7 DTMF MEMORY

8 SET MODES

9 PROGRAMMING

10 TROUBLESHOOTING

11 OPTIONS

INTRODUCTION

Thank you for choosing this Icom product. This product was designed and built with Icom's state of the art technology and craftsmanship. With proper care, this product should provide you with years of trouble-free operation.

IMPORTANT

READ ALL INSTRUCTIONS carefully and completely before using the transceiver.

SAVE THIS INSTRUCTION MANUAL — This instruction manual contains advanced operating instructions for the IC-G86. For basic operating instructions, see the **BASIC MANUAL**.

EXPLICIT DEFINITIONS

WORD	DEFINITION
⚠ WARNING!	Personal injury, fire hazard or electric shock may occur.
CAUTION	Equipment damage may occur.
NOTE	If disregarded, inconvenience only. No risk of personal injury, fire or electric shock.

FEATURES

- Rugged construction (IP54*1 and MIL-STD-810G)
 - ① Only when the battery pack or case, antenna, and jack cover or optional HM-168LWP, HS-94LWP, HS-95LWP are attached.
- Powerful 7 W of output power (Extra High power)
- Extend Battery Life function (With the BC-240)

Icom, Icom Inc. and the Icom logo are registered trademarks of Icom Incorporated (Japan) in Japan, the United States, the United Kingdom, Germany, France, Spain, Russia, Australia, New Zealand, and/or other countries.

All other products or brands are registered trademarks or trademarks of their respective holders.

Icom is not responsible for the destruction, damage to, or performance of any Icom or non-Icom equipment, if the malfunction is because of:

- Force majeure, including, but not limited to, fires, earthquakes, storms, floods, lightning, other natural disasters, disturbances, riots, war, or radioactive contamination.
- The use of Icom transceivers with any equipment that is not manufactured or approved by Icom.

Section 1 ACCESSORIES

Supplied accessories.....	1-2
Antenna	1-2
Belt clip	1-2
Battery pack or case.....	1-3
Jack cover	1-3

Supplied accessories

Battery pack

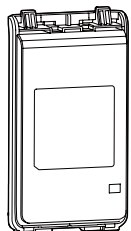

Antenna

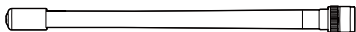

Jack cover
(with screws)

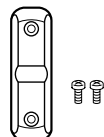

Belt clip



Battery charger

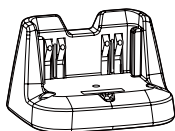

Power adapter

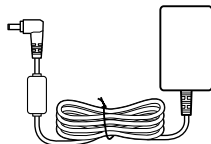

NOTE: Some accessories are not supplied, or the shape is different, depending on the transceiver version.

Antenna

Insert the antenna into the antenna connector and rotate the antenna base to lock it in place.

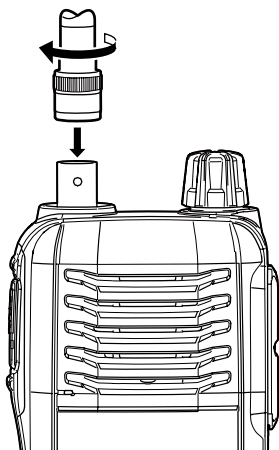

CAUTION:

- **DO NOT** carry the transceiver by holding only the antenna.
- **DO NOT** transmit without an antenna.

Belt clip

To attach the belt clip:

- Slide the belt clip in the direction of the arrow until the belt clip locks in place, and makes a 'click' sound.

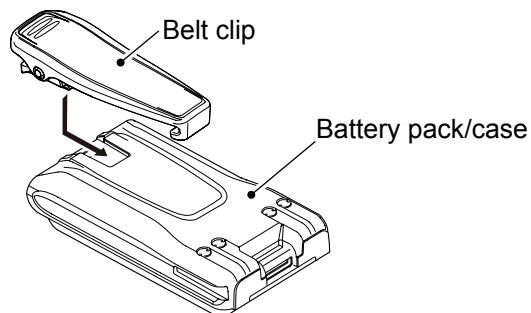

To detach the belt clip:

1. Remove the battery pack or case from the transceiver, if it is attached.
2. Lift the tab up (1), and slide the belt clip in the direction of the arrow (2).

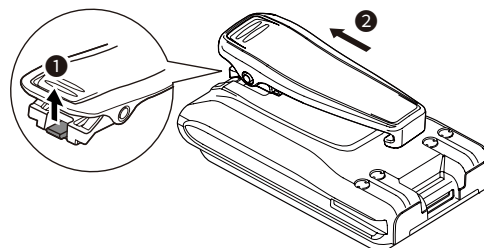

Battery pack

To attach:

1. Insert the battery pack in the direction of the arrow (①), then close.
2. Hook the latch until it makes a 'click' sound (②).

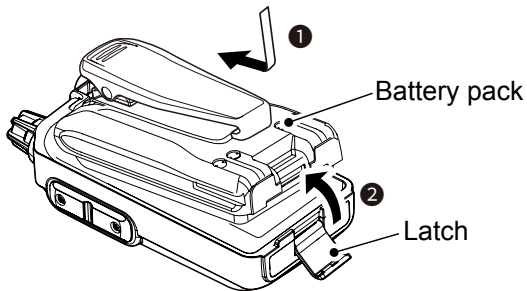

To detach:

⚠ **WARNING!** The latch is tightly locked, so use caution when releasing it. **DO NOT** use your fingernail. Use the edge of a coin or screwdriver tip to carefully release it.

- Unhook the latch (①), and then lift up the battery pack in the direction of the arrow (②).

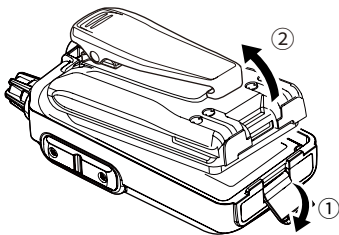

CAUTION: NEVER detach or attach the battery pack when the transceiver is wet or soiled. This may result in water or dust getting into the transceiver or the battery pack, and may result in them being damaged.

NOTE: Keep battery terminals clean. It's a good idea to occasionally clean them.

Jack cover

Attach the jack cover when optional equipment is not used.

To attach the jack cover

1. Attach the jack cover to the [SP MIC] jack (①).
2. Insert and tighten the screws (②).

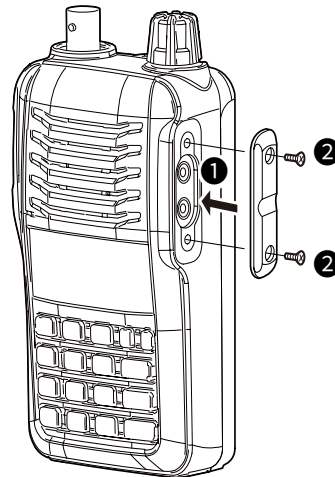

To detach the jack cover

1. Remove the screws with a phillips screwdriver (①).
2. Detach the jack cover to connect optional equipment (②).

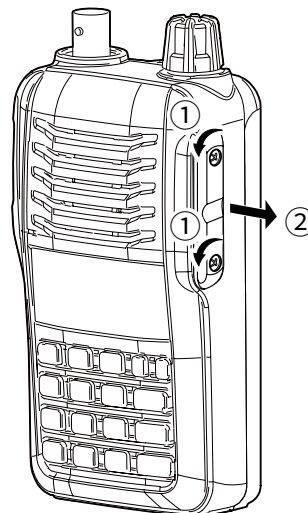

Section 2

BATTERY CHARGE

Battery chargers	2-2
◇ Using the BC-191 to rapid charge the BP-264	2-2
◇ Using the BC-192 to regular charge the BP-264	2-2
◇ Using the BC-240 to rapid charge the BP-298/BP-299	2-3

Battery chargers

◇ Using the BC-191 to rapid charge the BP-264

The BC-191 provides rapid charging of only the BP-264 Ni-MH battery pack. Never use it to charge any other battery pack.

Charging time: Approximately 2 hours

Additionally needed item (purchase separately):

A power adapter (not supplied with some transceiver versions) or the OPC-515L or CP-23L DC power cable.

- ① A power adapter may be a different type, or no power adapter is supplied, depending on the transceiver version.
- ① The optional OPC-515L (for a DC power source) or CP-23L (for a 12 V cigarette lighter socket) can be used instead of the power adapter.

NOTE: When the BC-191's charging indicator lights as below, it indicates the following states.

- Lights orange: While charging
- Lights green: When charging is completed.

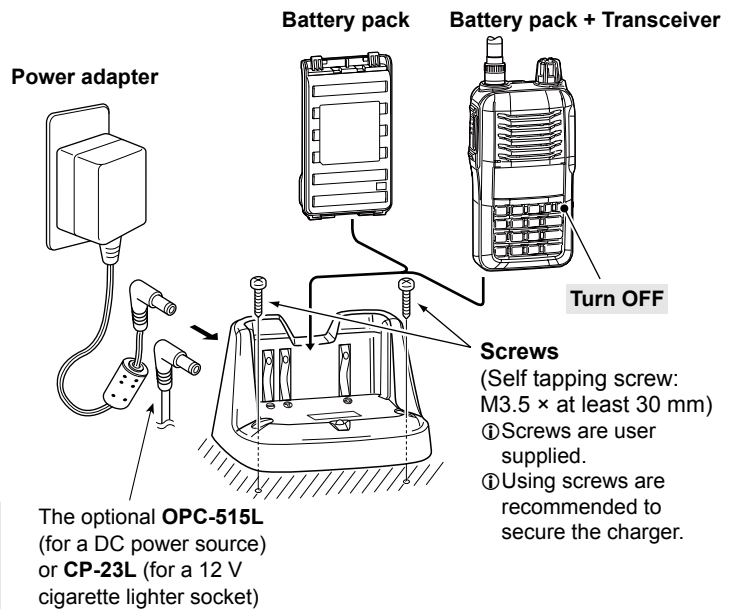

◇ Using the BC-192 to regular charge the BP-264

The BC-192 provides regular charging of only the BP-264 Ni-MH battery pack. Never use it to charge any other battery pack.

Charging time:

- At 12 V: Approximately 36 hours
- At 13.8 V: Approximately 21 hours
- At 16 V: Approximately 16 hours

- ① Charging time period differs, depending on the input voltage.

Additionally needed item (purchase separately):

A power adapter (not supplied with some transceiver versions) or the OPC-515L DC power cable.

- ① A power adapter may be a different type, or no power adapter is supplied, depending on the transceiver version.
- ① The optional OPC-515L (for a DC power source) can be used instead of the power adapter.

NOTE: When the BC-192's charging indicator lights as below, it indicates the following state.

- Lights green: While charging.
- ① The charge indicator will not go out even after a battery pack is fully charged.

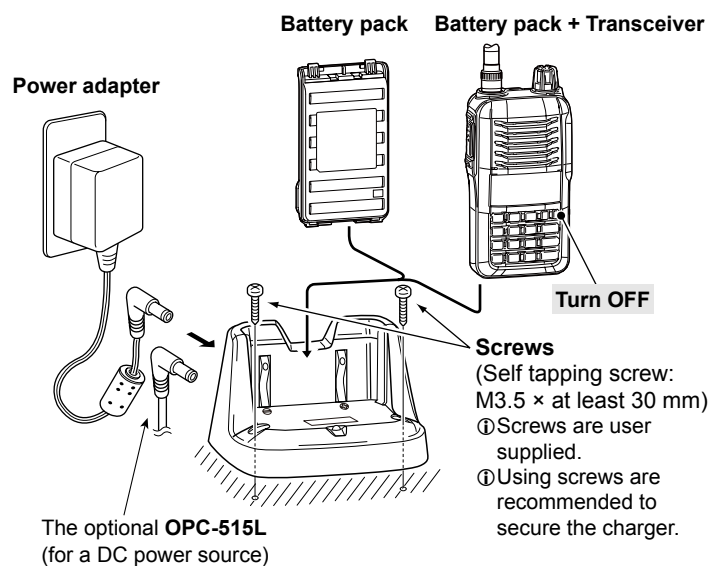

Battery chargers

◇ Using the BC-240 to rapid charge the BP-298/BP-299

The BC-240 provides rapid charging of only the BP-298/BC-299 Li-ion battery pack. Never use it to charge any other battery pack.

Charging time*

With the BP-298: Approximately 3 hours

With the BP-299: Approximately 4.6 hours

* When the Extend Battery Life function is turned OFF.
See the BASIC MANUAL for details.

Additionally needed item (purchase separately):

A power adapter (not supplied with some transceiver versions) or the OPC-515L or CP-23L DC power cable.

- ① A power adapter may be a different type, or no power adapter is supplied, depending on the transceiver version.
- ① The optional OPC-515L (for a DC power source) or CP-23L (for a 12 V cigarette lighter socket) can be used instead of the power adapter.

CAUTION: When using the OPC-515L DC power cable **NEVER** connect the OPC-515L to a power source using reverse polarity. This will ruin the battery charger. White line: ⊕ Black line: ⊖

NOTE: When the BC-240's charging indicator lights or blinks as below, it indicates the following states.

- Lights orange: While charging
- Lights green: When charging is completed.
- Blinks red: When a charging error has occurred. Reinstall the battery or the transceiver.

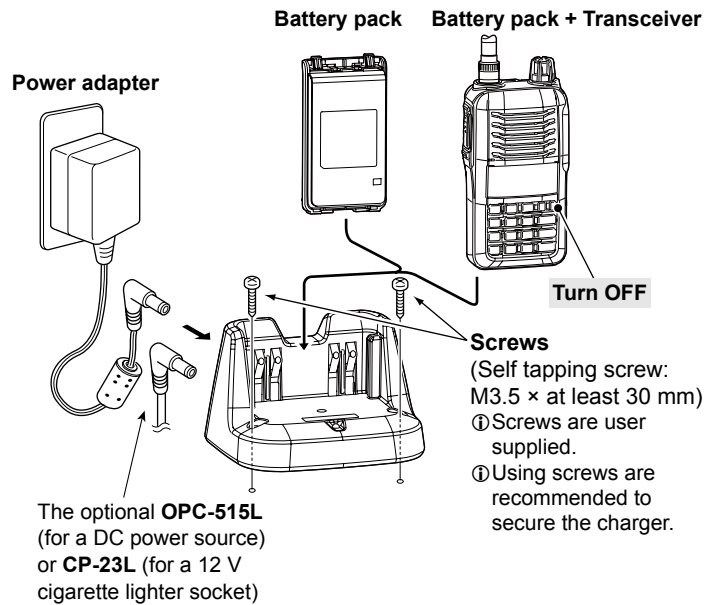

Section 3 **ADVANCED OPERATION**

Adjusting the audio level.....	3-2
Selecting passband width.....	3-2
[VOL] function assignment	3-2

Adjusting the audio level

- Rotate [VOL]* to adjust the audio level.
 - The display shows the audio level while adjusting.
 - ① If the squelch is closed, hold down [MONI] while adjusting the audio level.

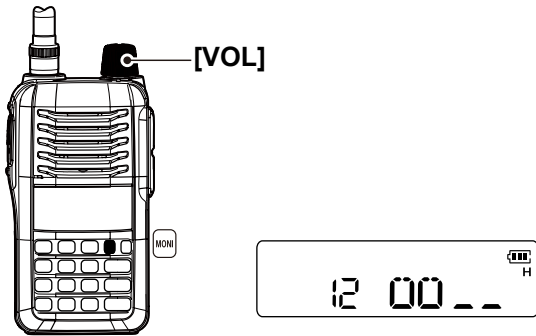

* Use [VOL] or [▲]/[▼], depending on the setting of the “Dial assignment” in the Initial Set mode. (p. 8-6)

Selecting passband width

Set both the transmission and reception passband width to wide or narrow.

1. Push [FUNC], and then push [SET] to enter the Set mode.
2. Push [▲] or [▼] to select the passband width item (W/n).
3. Rotate [VOL] to select the passband width.
 - “W”: Wide (FM mode)
 - “n”: Narrow (FM-N mode)
4. Push [# ENT] to exit the Set mode.

The “Passband width” item in the Set mode



(FM mode is selected)



(FM-N mode is selected)

[VOL] function assignment

[VOL] can be used as a channel selector instead of [▲] and [▼], to suit your preference. However, when [VOL] functions as a channel selector, [▲] and [▼] function as volume controls.

1. Hold down [⏻] for 1 second to turn OFF the power.
2. While holding down [▲] and [▼], turn ON the power to enter the Initial Set mode.
3. Push [▲] or [▼] to select the dial assignment item (tOP).
4. Rotate [VOL] to select an option.
5. Push [# ENT] to exit the Initial Set mode.

[VOL] and [▲]/[▼] function as described below, depending on the option.

Option	[VOL]	[▲]/[▼]
tOP.VO	Volume control	Channel selector
tOP.di	Channel selector	Volume controls

The “Dial assignment” item in the Set mode



[VOL] functions as the volume control.



[VOL] functions as the channel selector.

Section 4 REPEATER OPERATION

About repeater.....	4-2
Talk Around function	4-2
DTCS encoder (Only TX)	4-3
Lockout function	4-3
Subaudible tones.....	4-3

About repeater

To communicate with another station in an area where radio waves cannot directly received, you can use a repeater as a relay. This is called duplex operation. The frequencies are pre-programmed into an operating channel for duplex operation. Ask your dealer for details.

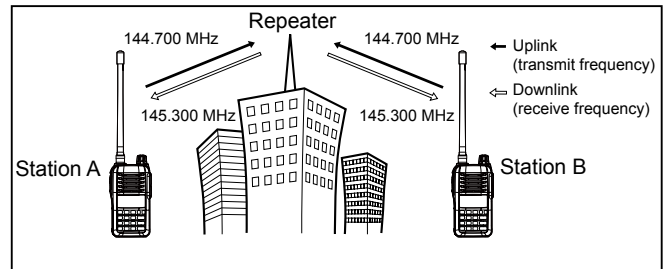

1. Push [▲] or [▼] to select a channel that has been programmed for repeater use.
 - ① The frequencies are pre-programmed into channels using the CS-G86 PROGRAMMING SOFTWARE. Ask your dealer for details.
2. Push [FUNC], and then push [TONE] several times to turn ON the subaudible tone encoder, depending on the repeater requirements.
 - “♪” is displayed.
 - ① The subaudible tone frequency can be set in the Set mode.
3. Hold down [PTT] to transmit.
4. Release [PTT] to receive.
5. Hold down [MONI] to check whether you can directly receive the signal from the other station.
 - ① When the other station’s signal can be directly received, move to a non-repeater frequency to use simplex. (duplex OFF)

Turning ON the subaudible tone encoder

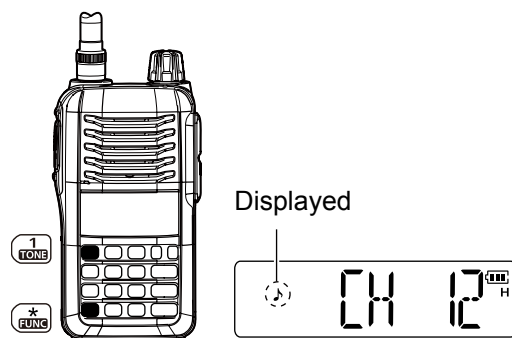

Talk Around function

The Talk Around function equalizes the transmit frequency to the receive frequency for transceiver-to-transceiver communication. Duplex operation temporarily changes to simplex operation.

This function is convenient at the following situations when:

- The repeater is broken down and is not usable.
- You cannot access the repeater because of distance, low power or location.
- You can easily contact the other transceiver without using the repeater.

1. Push [▲] or [▼] to select a channel that has been programmed for repeater use.
2. Push [FUNC] and then push [T/A] to turn ON the Talk Around function.
 - “±” is displayed.
3. Push [PTT] to transmit.
4. Release [PTT] to receive on the same frequency.
 - The transmit frequency is same as the receive frequency.

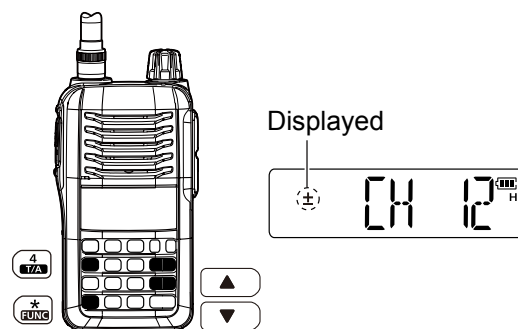

Turning ON the Talk Around function



DTCS encoder (Only TX)

The DTCS encoder superimposes the selected DTCS code over your transmitted signal.

1. Push [FUNC], and then push [SET] to enter the Set mode.
2. Set the DTCS code and polarity, in the same way you set the DTCS squelch. (p. 6-2)
 - ① You can set the DTCS transmit and receive polarity, but the DTCS encoder affects only transmit.
3. Push [# ENT] to exit the Set mode.
4. Push [FUNC], and then push [TONE] several times, until both “0” and “J” are displayed.
 - The DTCS encoder is activated.





Push , and then push  several times to turn ON the DTCS encoder.



DTCS encoder (Only TX)

Lockout function

This function helps prevent interference to other stations by inhibiting transmitting when a signal is received. The transceiver has two inhibiting modes, repeater and busy.

1. Hold down  for 1 second to turn OFF the transceiver.
2. While holding down  and , turn ON the transceiver to enter the Initial Set mode.
3. Push  or  to select the lockout item (RLO).
4. Rotate [VOL] to select the Lockout function option of “RP,” “bU” or “OF.”
 - “RLO.OF”: The Lockout function is OFF.
 - “RLO.RP”: The transmit is inhibited when a signal with an unmatched subaudible tone is received.
 - “RLO.bU”: Transmit is inhibited when a signal is received.
5. Push [# ENT] to exit the Initial Set mode.

The “Lockout” item in the Initial Set mode



(The Repeater Lockout function is OFF.)



(The Repeater Lockout function is ON.)



(The Busy Lockout function is ON.)

Subaudible tones

Some repeaters require subaudible tones to access. Subaudible tones are superimposed over your normal signal, and must be set in advance.

1. Push [FUNC], and then push [SET] to enter the Set mode.
2. Push [▲] or [▼] to select the repeater tone item.(rt)
3. Rotate [VOL] to select the desired subaudible tone frequency.
4. Push [#ENT] to exit the Set mode.

◇ Tone information

Some repeaters require a different tone system to be accessed.

DTMF Tones

While holding down [PTT], push the desired DTMF keys, [0] to [9], [MONI](A), [▲](B), [▼](C), [↻](D), [*](E), and [#ENT](F) to transmit their assigned DTMF codes.

DTCS codes

Push [FUNC](*), and then [TONE](1) one or more times to activate the DTCS encoder, and then push [PTT].

- “@” and “♪” is displayed.
- The specified DTCS code is superimposed over your transmitted signal.

① See the CTCSS tone or DTCS code. (p. 6-2)

NOTE: If you don't know the subaudible tone or DTCS code used for a repeater, the tone scan is convenient for detecting it.

Push [FUNC](*), and then [T.SCAN](3) to start a tone scan.

- When the required tone frequency or DTCS code is detected, the scan pauses, and it is temporarily set.

① See the Tone scan function. (p. 6-5)

Setting the subaudible tone

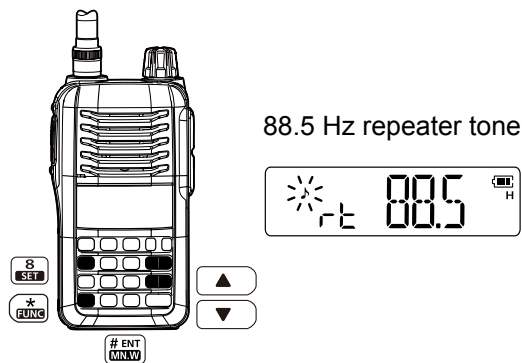

Available subaudible tones

67.0	79.7	94.8	110.9	131.8	156.7	171.3	186.2	203.5	229.1
69.3	82.5	97.4	114.8	136.5	159.8	173.8	189.9	206.5	233.6
71.9	85.4	100.0	118.8	141.3	162.2	177.3	192.8	210.7	241.8
74.4	88.5	103.5	123.0	146.2	165.5	179.9	196.6	218.1	250.3
77.0	91.5	107.2	127.3	151.4	167.9	183.5	199.5	225.7	254.1

Section 5 SCAN OPERATION

Scan types.....	5-2
◇ Memory scan	5-2
◇ Priority watch	5-2
Setting Skip channels.....	5-3
Scan Resume setting	5-3

Scan types

A scan automatically searches for signals, and makes it easier to locate new stations for contact or listening purposes.

◇ Memory scan

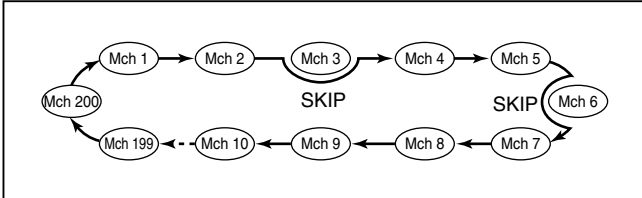

Repeatedly scans memory channels, except those set as skip channels, described in the next scan topic.

1. Push [FUNC], and then push [SCAN] to start the scan.
 - “MR” blinks.
 - ① To change the scan direction, push [▲] or [▼].
2. To cancel the scan, push any key except [⏻], [▲]/[▼], [MONI] or [FUNC].

◇ Priority watch

The priority watch checks for signals on the selected channel (Priority channel) every 5 seconds. A priority channel must be set first.

Setting the Priority channel

1. Push [▲] or [▼] to select the channel.
2. Push [FUNC], and then hold down [PRIO] for 1 second to set the selected channel as a Priority channel.
 - 2 beeps sound and “PRIO” is displayed for 1 second.

Starting Priority Watch

3. Push [FUNC], and then [PRIO] to start the Watch.
 - The decimal point “.” on the alphanumeric display blinks.
 - When a signal is received on the channel, the Watch pauses, and resumes depending on the selected scan resume option.
4. To cancel the watch, push any key except [⏻], [▲]/[▼], [MONI], [FUNC], or [PTT].

Setting Skip channels

The Memory Skip function speeds up scanning by not scanning those memory channels set as Skip channels. Set the Skip channels as follows.

1. Push [▲] or [▼] to select the memory channel to be skipped.
2. Push [FUNC], and then push [SKIP] to set the channel as a Skip channel.
 - “SKIP” is displayed.

Example: Setting memory channel 11 as the Skip channel.

Push [▲] or [▼] to select channel 11.



Push [FUNC], and push [SKIP].



Displayed

Scan Resume setting

Various pause and timer options can be selected with the Scan Resume function. The selected resume option is also used for Priority Watch.

1. Push [FUNC], and then push [SET] to enter the Set mode.
2. Push [▲] or [▼] to select the scan pause timer item (SCt, or SCP).
3. Rotate [VOL] to select the desired scan resume option.
 - “SCt. 5/10/15”: Timer scan
The scan pauses for 5 to 15 seconds, when a signal is received.
 - “SCP. 2”: Pause scan
The scan pauses, then resumes 2 seconds after the signal disappears.
4. Push [# ENT] to exit the Set mode.

The “Scan pause timer” item in the Set mode



(Pause scan is selected.)



(Timer scan (15 seconds) is selected.)

Section 6

TONE SQUELCH AND POCKET BEEP

Tone/DTCS squelch.....	6-2
◇ Tone squelch and DTCS squelch	6-2
◇ Setting CTCSS tone or DTCS code.....	6-2
◇ Setting DTCS polarity	6-2
◇ Operation	6-3
Pocket Beep function.....	6-4
Tone scan	6-5

Tone/DTCS squelch

◇ Tone squelch and DTCS squelch

The tone squelch or DTCS squelch opens when a signal with the same pre-programmed CTCSS tone or DTCS code is received.

Recommended CTCSS tones

67.0	79.7	94.8	110.9	131.8	156.7	186.2	225.7
69.3	82.5	97.4	114.8	136.5	162.2	192.8	233.6
71.9	85.4	100.0	118.8	141.3	167.9	203.5	241.8
74.4	88.5	103.5	123.0	146.2	173.8	210.7	250.3
77.0	91.5	107.2	127.3	151.4	179.9	218.1	

Recommended DTCS codes

023	051	114	143	174	251	315	371	445	532	631	723
025	054	115	152	205	261	331	411	464	546	632	731
026	065	116	155	223	263	343	412	465	565	654	732
031	071	125	156	226	265	346	413	466	606	662	734
032	072	131	162	243	271	351	423	503	612	664	743
043	073	132	165	244	306	364	431	506	624	703	754
047	074	134	172	245	311	365	432	516	627	712	

◇ Setting CTCSS tone or DTCS code

1. Push [FUNC], and then push [SET] to enter the Set mode.
2. Push [▲] or [▼] to select the Tone squelch frequency item (Ct) or the DTCS code item (dt).
 - “Ct” blinks when selecting the Tone squelch frequency item, and “dt” blinks when selecting the DTCS code item.
3. Rotate [VOL] to set the desired CTCSS tone, or DTCS code.
4. Push [# ENT] to exit the Set mode.

The “Tone squelch frequency” item in the Set mode

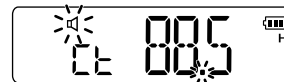

CTCSS tone setting (88.5 Hz is selected.)

The “DTCS code” item in the Set mode

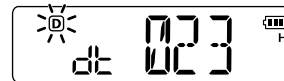

DTCS code setting (023 is selected.)

◇ Setting DTCS polarity

For DTCS operation, the polarity setting is also configurable, as well as the code setting. If the polarity is different, the DTCS squelch never opens, even when receiving a signal that includes a matching DTCS code.

1. Push [FUNC], and then push [SET] to enter the Set mode.
2. Push [▲] or [▼] to select the DTCS polarity item (dtP).
3. Rotate [VOL] to select the desired polarity.
 - “dtP.nn”: Normal
 - “dtP.nR”: Normal for TX, reverse for RX
 - “dtP.Rn”: Reverse for TX, normal for RX
 - “dtP.RR”: Reverse
4. Push [# ENT] to exit the Set mode.

The “DTCS polarity” item in the Set mode

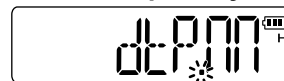

TX and RX: Normal polarity



TX: Normal, RX: Reverse



TX: Reverse, RX: Normal

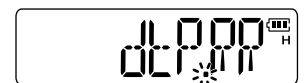

TX and RX: Reverse polarity

Tone/DTCS squelch

◇ Operation

1. Select the operating channel.
2. Push [FUNC], and then push [SET] to enter the Set mode.
3. Set the tone frequency, or DTCS code and DTCS polarity.
4. Push [# ENT] to exit the Set mode.
5. Push [FUNC], and then push [TONE] several times, until the icon of desired Tone function is displayed.
 - “J”: Repeater tone encoder
 - “Q” and “U”: CTCSS Pocket Beep function
 - “Q”: CTCSS squelch function
 - “D” and “J”: DTCS encoder (Only TX)
 - “D” and “U”: DTCS Pocket Beep function
 - “D”: DTCS squelch function
- ① When the CTCSS or DTCS squelch function is ON, the tone encoder is activated while transmitting.
6. Operate the transceiver in a normal way; push [PTT] to transmit, release [PTT] to receive.
7. When a signal with matching tones or codes is received, the squelch opens and audio is heard.
 - ① To manually open the squelch, push [MONI].
 - ① If the signal includes an unmatching tones, the squelch does not open. However, the icon shows the strength of the received signal.
8. To cancel the tone or DTCS squelch, push [FUNC], and then push [TONE] several times, until the tone icon disappears.

Push [FUNC], and then push [TONE] to sequentially select the tone function.

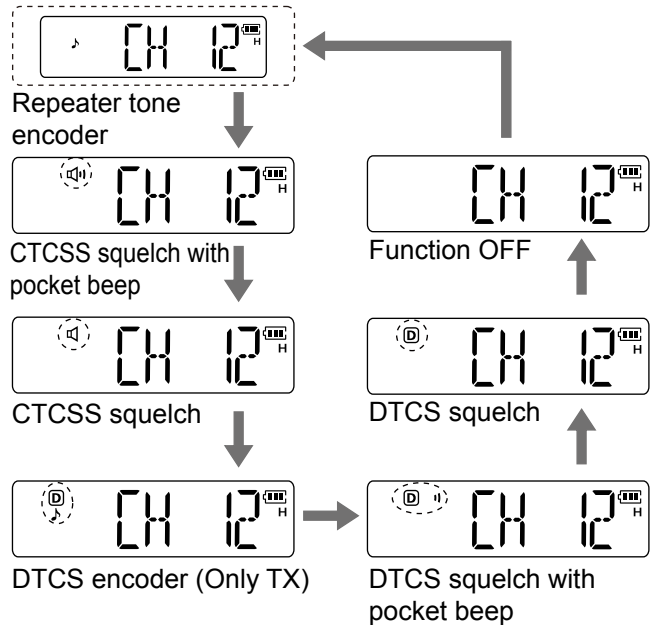









CTCSS burst:

While using the tone squelch, noise may be heard just when the received signal disappears. To eliminate the noise, the transceiver has the CTCSS Burst function. See page 8-7 for details.

Pocket Beep function

This function uses subaudible tones for calling, and can be used as a “common pager” to inform you that someone has called while you were away from the transceiver.

1. Select the operating channel.
2. Push [FUNC], and then push [SET] to enter the Set mode.
3. Set the tone frequency, or DTCS code and DTCS polarity.
4. Push [# ENT] to exit the Set mode.
5. Push [FUNC], and then push [TONE] several times, until the icon of desired Tone function and “” is displayed.
 - “” and “”: CTCSS Pocket Beep function
 - “” and “”: DTCS Pocket Beep function
6. When a signal with matching tones or codes is received, beep tones sound and “” blinks.
① To stop the beeps and blinking, push any key.
7. To cancel the tone or DTCS squelch, push [FUNC], and then push [TONE] several times, until the tone icon disappears.

Push , and then push  several times to turn ON the Pocket Beep function.



CTCSS squelch with pocket beep



DTCS squelch with pocket beep

Tone scan

By monitoring a signal that is being operated with the pocket beep, tone or DTCS Squelch function turned ON, you can determine the tone frequency or DTCS code necessary to open the squelch.

1. Select a channel to check for a tone frequency or DTCS code.
2. Push [FUNC], and then push [TONE] several times, until the icon of desired Tone function is displayed.
 - **For a CTCSS tone scan:**
The scan starts without selecting a tone function.
3. Push [FUNC], and then push [T.SCAN] to start the tone scan.
 - ① To change the scan direction, push [▲] or [▼].
4. When the CTCSS tone frequency or DTCS code is detected, the squelch opens and the detected tone frequency is temporarily programmed into the selected mode.
 - The detected CTCSS tone frequency or DTCS code is used for the tone encoder or decoder, according to the tone condition or type selected in step 2.
 - No icon: Cannot be used for the operation.
 - “♪”: Repeater tone encoder
 - “Ⓢ” and “♫”: DTCS encoder (Only TX)
 - “♫”: CTCSS tone encoder or decoder
 - “Ⓢ”: DTCS code encoder or decoder
5. To cancel the scan, push any key except [⏻], [▲]/[▼], [MONI] or [FUNC].

Example: A DTCS code scan on CH 12.

Select the operating channel.



Push [FUNC], and then push [1] several times to select the DTCS squelch function.



Displayed

Push [FUNC], and then push [3].

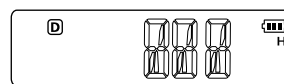

During the DTCS code scan.

Section 7 DTMF MEMORY

Programming a DTMF code sequence.....	7-2
Transmitting a DTMF code	7-3
◇ Selecting the DTMF code transmission option	7-3
◇ Manual DTMF code transmission	7-3
◇ Using a DTMF memory channel	7-3
◇ DTMF code transmission interlocking with PTT.....	7-3
Monitoring a DTMF memory.....	7-4
Setting DTMF transfer speed	7-4

Programming a DTMF code sequence

DTMF codes are used for autopatching, controlling other equipment, and so on. The transceiver has up to 16 DTMF memory channels (d0–dF) for up to 24 digits often-used DTMF codes.

1. Push [FUNC], and then push [DTMF-M] to enter the DTMF memory mode.
2. Push [▲] or [▼] to select the desired blank DTMF memory channel.
 - The selected DTMF memory channel blinks.
 - If programmed, the previously programmed DTMF code is displayed.

NOTE: Previously programmed code sequence in the selected DTMF memory channel will be cleared by the following operation.

3. Push [FUNC], and then hold down [DTMF-M] for 1 second to enter the DTMF memory programming mode.
 - “_ _ _ _ _” is displayed.
4. Push a key to input the desired DTMF code.
 - Refer to the illustration below for the DTMF code assignment.
 - ① If a digit is mistakenly input, push [PTT] momentarily, and then repeat from step 3.
5. Repeat step 4, until the desired DTMF code sequence (up to 24 digits) is complete.
 - When the 6th character is set, the icon displays the next blank digit group.
6. Push [PTT] to save the channel and exit the DTMF memory programming mode.
 - After the 24th digit is input, the transceiver automatically saves the code sequence and returns to the DTMF memory mode (step 2).
7. Push [r-O] to exit the DTMF memory mode.

Example: Programming “123456” into the DTMF memory channel “d3.”

Push [* FUNC], and then push [0 DTMF-M].

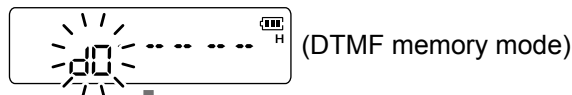

Push [▲] or [▼] to select DTMF memory channel “d3.”

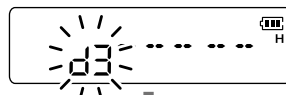

Push [* FUNC], and then hold down [0 DTMF-M] for 1 second.

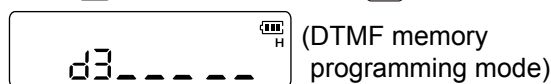

Push keys, until the desired DTMF code is complete.

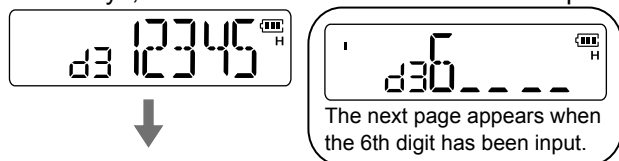

Push [PTT].

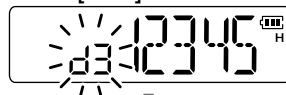

Push [r-O] to exit the DTMF memory mode.



DTMF code assignment

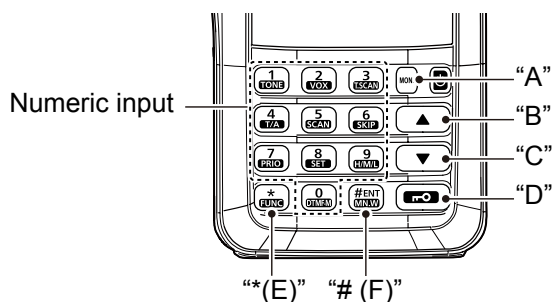

Programming mode indication

The programming mode consists of 5 groups.

Group	Digits	Icon
1st	1st to 5th	No icon.
2nd	6th to 10th	“_” is displayed.
3rd	11th to 15th	“ ” is displayed.
4th	16th to 20th	“ ” is displayed.
5th	21st to 24th	“ ” blinks.

Transmitting a DTMF code

The transceiver has three methods of transmitting a DTMF code sequence. Select the desired option in the Set mode.

◇ Selecting the DTMF code transmission option

1. Push [FUNC], and then push [SET] to enter the Set mode.
2. Push [▲] or [▼] to select the DTMF TX key item (dmt).
3. Rotate [VOL] to select the desired option.
 - “dmt.k”: Manual transmission
Transmits the appropriate DTMF code assigned to the key.
 - “dmt.m”: Using DTMF memory
Transmits the programmed DTMF code sequence in the DTMF memory channel assigned to the key.
4. Push [# ENT] to exit the Set mode.

The “DTMF TX key” item in the Set mode



Manual transmission



Using DTMF memory

◇ Manual DTMF code transmission

1. Set the DTMF TX key to “dmt.k” in the Set mode.
2. While holding down [PTT], push the desired keys to manually transmit a DTMF code sequence.

DTMF code assignment

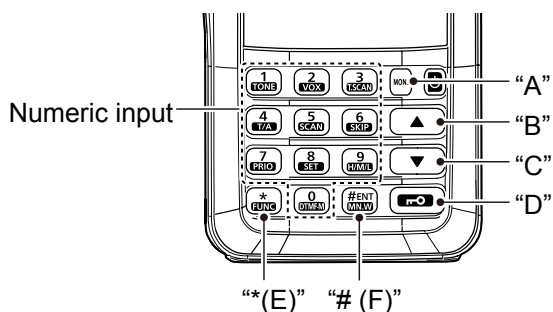

◇ Using a DTMF memory channel

1. Set the DTMF TX key to “dmt.m” in the Set mode.
2. While holding down [PTT], push the desired DTMF channel number.

DTMF memory channel number assignment

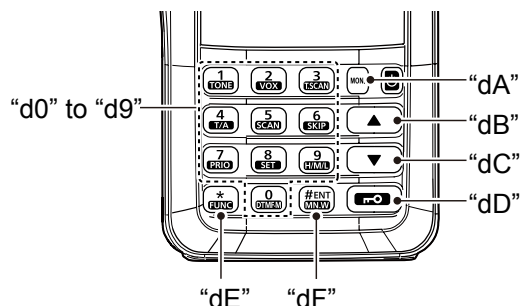

◇ DTMF code transmission interlocking with PTT

By setting the Log-In/Off setting on each operating channel, you transmit the programmed DTMF code sequence when pushing or releasing [PTT]. The Log-In/Off setting and the DTMF code to send are pre-programmed using the CS-G86 PROGRAMMING SOFTWARE. Ask your dealer for details.

Monitoring a DTMF memory

You can monitor the programmed DTMF code sequence.

1. Push [FUNC], and then push [DTMF-M] to enter the DTMF memory mode.
2. Push [▲] or [▼] to select the desired DTMF memory channel.
3. Push [MONI] to monitor the DTMF memory contents.
 - The programmed DTMF code sequence sounds, and then the transceiver automatically exits the DTMF memory mode.

Example: Monitoring DTMF memory channel “d3.”

Push and then push .

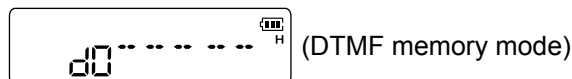

Push or to select DTMF memory channel “d3.”

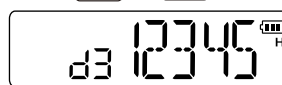

Push [MONI].

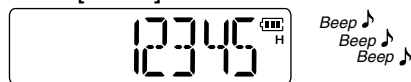

The DTMF code sequence sounds.

Setting DTMF transfer speed

The transmitting speed of DTMF code programmed in the DTMF memory mode can be set to accommodate your operating needs.

1. Hold down for 1 second to turn OFF the transceiver.
2. While holding down and , hold down for 1 second, to turn ON the transceiver to enter the Initial Set mode.
3. Push or to select the DTMF TX speed item (dtd).
4. Rotate [VOL] to select the desired transmitting speed, as shown below.
 - “dtd. 1”: 100 milliseconds interval; 5.0 cps rate
 - “dtd. 2”: 200 milliseconds interval; 2.5 cps rate
 - “dtd. 3”: 300 milliseconds interval; 1.6 cps rate
 - “dtd. 5”: 500 milliseconds interval; 1.0 cps rate

(cps=characters per second)
5. Push [# ENT] to exit the Initial Set mode.

The “DTMF TX speed” item in the Initial Set mode



(“3” is selected.)

Section 8 SET MODES

Using the Set mode.....	8-2
Set mode items.....	8-2
Using the Initial Set mode.....	8-5
Initial Set mode items	8-5

Using the Set mode

The Set mode is used to change the settings of the transceiver's functions.

1. Push [FUNC], and then push [SET] to enter the Set mode.
2. Push [▲] or [▼] to select the desired item.
3. Rotate [VOL] to select an option or value.
4. Push [# ENT] to exit the Set mode.

Set mode items

NOTE: The Set mode items contained in the transceiver may be different, depending on the transceiver's version or presetting. Ask your dealer for details.

Repeater tone frequency

Select the subaudible tone needed to access the repeater. A total of 50 tone frequencies (67.0 ~ 254.1 Hz) are selectable. (Default: 88.5 Hz)

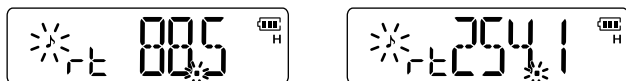

Tone squelch frequency

Select the CTCSS tones to use for the Tone Squelch function. A total of 50 tones (67.0 ~ 254.1 Hz) are selectable. (Default: 88.5 Hz)

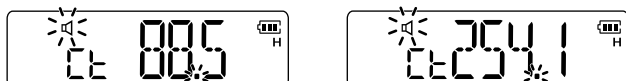

Usable CTCSS tones (unit: Hz)

67.0	79.7	94.8	110.9	131.8	156.7	171.3	186.2	203.5	229.1
69.3	82.5	97.4	114.8	136.5	159.8	173.8	189.9	206.5	233.6
71.9	85.4	100.0	118.8	141.3	162.2	177.3	192.8	210.7	241.8
74.4	88.5	103.5	123.0	146.2	165.5	179.9	196.6	218.1	250.3
77.0	91.5	107.2	127.3	151.4	167.9	183.5	199.5	225.7	254.1

The transceiver has 50 CTCSS tones and consequently their spacing is narrow compared with units having 38 tones. Therefore, some CTCSS tones may receive interference from adjacent tone frequencies.

DTCS Code

Set the DTCS code (both encoder and decoder) for DTCS squelch operation. A total of 104 codes are selectable. (Default: 023)

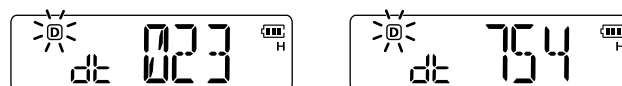

Available DTCS codes

023	054	125	165	245	274	356	445	506	627	732
025	065	131	172	246	306	364	446	516	631	734
026	071	132	174	251	311	365	452	523	632	743
031	072	134	205	252	315	371	454	526	654	754
032	073	143	212	255	325	411	455	532	662	
036	074	145	223	261	331	412	462	546	664	
043	114	152	225	263	332	413	464	565	703	
047	115	155	226	265	343	423	465	606	712	
051	116	156	243	266	346	431	466	612	723	
053	122	162	244	271	351	432	503	624	731	

DTCS Polarity

Set the Transmit and Receive DTCS polarity to "NN," "NR," "RN" or "RR." The polarity for transmitting or receiving can be independently set. (Default: dtP.nn)

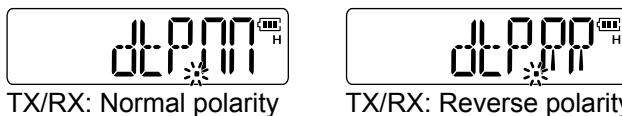

TX/RX: Normal polarity

TX/RX: Reverse polarity

Scan resume setting

Select the scan resume option from SCt. 5, SCt. 10, SCt. 15, or SCP. 2. (Default: SCt. 15)

- SCt. 5/10/15: The scan pauses for 5 to 15 seconds, when a signal is received.
- SCP.2: The scan pauses, then resumes 2 seconds after the signal disappears.

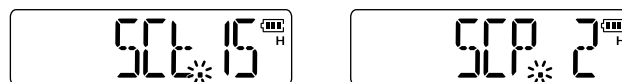

Set mode items

Function key timer

Push [FUNC] to enter the Function mode, and then push a keypad key to activate its second function.

- While in the Function mode, "F" is displayed on the LCD.

Set the time between when the Function mode is entered, and how long it remains activated after you push the keypad key to activate its second function.

(Default: F0.At)

- F0.At: Exits the Function mode immediately after a key is pushed to activate its second function.
- F1/2/3.At: The Function mode remains activated 1, 2 or 3 seconds after a key is pushed to activate its second function.
- F.m: The Function mode remains activated until [FUNC] is pushed again, even after a key is pushed to activate its second function.



LCD backlight

Select the LCD Backlight function. (Default: LIG.At)

- LIG.OF: Turns the backlight function OFF.
- LIG.ON: Lights continuously while the transceiver is ON.
- LIG.At: Turns ON when an operation occurs, and turns OFF after 5 seconds.



VOX gain

Set the VOX gain to between 1 and 10. Higher values make the VOX function more sensitive to your voice. To turn OFF the VOX function, select "VOX.OF."

(Default: VOX.05)



NOTE: Set the microphone gain before setting the VOX gain. See page 11-4 for details of the VOX function.

MIC gain

Set the microphone gain to between 1 and 4, to suit your preference. Higher values makes the microphone more sensitive to your voice. (Default: mic.2)

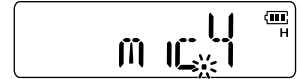
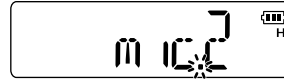

NOTE: When using the VOX function, we recommend setting the microphone gain to 3. However, you can adjust it to suit your operating environment (including your headset performance).

VOX delay

The VOX Delay is the amount of time the transmitter stays ON after you stop speaking. (Default: VXd.10)

- VXd.05: 0.5 seconds delay
- VXd.10: 1 second delay
- VXd.15: 1.5 seconds delay
- VXd.20: 2 seconds delay
- VXd.25: 2.5 seconds delay
- VXd.30: 3 seconds delay

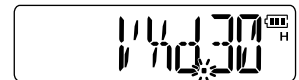
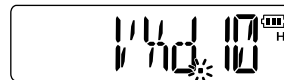

VOX time-out timer

Set the VOX time-out timer to between 1, 2, 3, 4, 5, 10, and 15 minutes, to prevent accidental prolonged transmission by the VOX function. To turn OFF the function, select "Vto.OF." (Default: 3)

The "VOX time-out timer" item in the Set mode



The VOX time-out timer is set to 3 minutes.



VOX time-out timer is set to 15 minutes (maximum).

The VOX time-out timer must be set shorter than the Time-out timer, otherwise the VOX time-out timer will not function.

Set mode items

DTMF TX key

Selects the method to transmit a DTMF code sequence. (Default: dmt.k)

- dmt.k: Transmits the appropriate DTMF code assigned to the key. (p. 7-3)
- dmt.m: Transmits the programmed DTMF code sequence in the DTMF memory channel assigned to the key.



Mode

Set both the transmission and reception passband width to wide or narrow. (Default: W/n. W)



Wide (FM mode)



Narrow (FM-N mode)

Using the Initial Set mode

The initial Set mode can be accessed at power ON, and allows you to set seldom-changed settings. In this way, you can “customize” the transceiver to suit your preference and operating style.

1. While holding down [▲] and [▼], hold down [Ⓟ] for 1 second to enter the Initial Set mode.
2. Push [▲] or [▼] to select the desired item.
3. Rotate [VOL] to select an option or value.
4. Push [# ENT] to exit the initial Set mode.

Initial Set mode items

Extra High Power

Select whether or not to display and select EXH (Extra High) as the highest power of the transceiver.

(Default: EXH.OF)

- EXH.OF: Displays and selects High as the highest power level of the transceiver.
- EXH.On: Displays and selects Extra High as the highest power level of the transceiver.

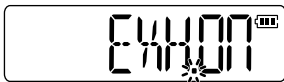

Key-touch beep

Set the confirmation beeps to between 1 and 3.

To turn OFF the confirmation beeps, select “bEP.OF.” (Default: bEP. 2)

- When changing the beep level, beeps sound at the level.



Time-out timer

To prevent accidental prolonged transmission, the transceiver has a time-out timer. The function inhibits continuous transmissions longer than the set time period (1 ~ 30 minutes). (Default: tot. 5)

- tot.OF: Turns OFF the function.
- tot. 1 ~ 30: Transmission is cut OFF after the set time period ends.

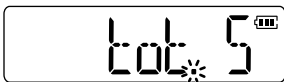

Approximately 10 seconds before the Time-out timer is activated, the transceiver emits a beep tone as a warning.

BE CAREFUL! When using the BP-263 BATTERY CASE, the batteries will become hot if this Time-out Timer function is turned OFF or set to a long time period, and transmission is made for long periods.

Auto power-OFF

The transceiver can be automatically turned OFF, when no key operation is performed for the specified period of time. 30 minutes, 1 hour, 2 hours and OFF are selectable. (Default: POF.OF)

- POF.OF: Turns the function OFF.
- POF.30/1H/2H: The transceiver is automatically turned OFF, when no key operation is performed for the specified time period.



NOTE: The setting is retained, even if the transceiver is turned OFF by the Auto Power OFF function. To cancel the function, select “POF.OF.”

Lockout

Set the transmission lockout (temporary transmission inhibit) capability. (Default: RLO.OF)

- RLO.OF: Turns OFF the function.
- RLO.RP: The transmit is inhibited when a signal with an unmatching subaudible tone is received.
- RLO.bU: Transmit is inhibited when a signal is received.



Squelch delay

Set the squelch delay to short or long. The delay prevents the squelch from repeatedly opening and closing, while receiving the same signal.

(Default: Sqd. S)

- Sqd. S: Short squelch delay.
- Sqd. L: Long squelch delay.



Initial Set mode items

DTMF speed

Set the rate at which DTMF memories send individual DTMF characters to accommodate your operating needs. (Default: dtd. 1)

- dtd. 1: 100 milliseconds interval: 5.0 cps rate
 - dtd. 2: 200 milliseconds interval: 2.5 cps rate
 - dtd. 3: 300 milliseconds interval: 1.6 cps rate
 - dtd. 5: 500 milliseconds interval: 1.0 cps rate
- (cps=characters per second)



Dial assignment

Selects whether or not to use [VOL] as a channel selector, instead of [▲] and [▼]. When [VOL] functions as a channel selector, [▲] and [▼] function as volume controls.

(Default: tOP.VO)

Option	[VOL]	[▲]/[▼]
tOP.VO	Volume control	Channel selectors
tOP.di	Channel selector	Volume controls



Simple mode

Selects whether or not to inhibit the access to some functions in the Set mode. (Default: SmP.OF)

- SmP.OF: All settings can be accessed.
- SmP.On: Some functions cannot be accessed.



NOTE: When “SmP.On” is selected, only the following functions can be accessed in the Set mode.

- Scan resume setting
- Function key timer
- LCD backlight
- VOX gain
- MIC gain
- VOX delay
- VOX time-out timer
- DTMF TX key

LCD contrast

Selects the LCD contrast. (Default: Lcd.At)

- Lcd.LO: Sets the contrast to low.
 - Lcd.At: Sets the contrast to high.
- However, if the transceiver is exposed to high temperatures, it automatically sets the contrast to low.



Power save

The Power Save function enables you to conserve battery life by selecting the duty cycle of the receiver. Select the ratio of the power save time to the standby time. To turn OFF the function, select “P-S.OF.”

(Default: P-S.At)

- P-S.OF: Turns OFF the function.
- P-S. 2: Sets the duty cycle to 1:2. (ON: 0.1 second, OFF: 0.2 seconds)
- P-S. 8: Sets the duty cycle to 1:8. (ON: 0.1 second, OFF: 0.8 seconds)
- P-S.16: Sets the duty cycle to 1:16. (ON: 0.1 second, OFF: 1.6 seconds)
- P-S.At: Automatically sets the duty cycle. When no operation occurs and no signal is received for 5 seconds, the transceiver enters the Power Save mode, and sets “1:2” as the duty cycle, and after 60 seconds, it sets “1:16” as the duty cycle.

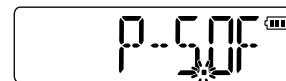
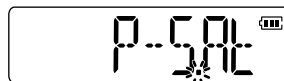

Select speed

Selects whether or not to accelerate the turning speed when rotating [VOL] rapidly. (Default: S-S. At)

- S-S. m: Turns OFF the tuning speed acceleration.
- S-S. At: The turning speed is automatically accelerated when rapidly rotating [VOL].

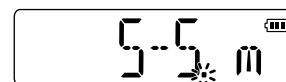
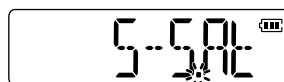

Initial Set mode items

Microphone simple mode

Microphone Simple mode is used to assign the essential operations to the four switches (S1 to S4) on the remote control unit. (Default: mS .n1)

- mS .Sm

S1	—
S2	Turns the Monitor function ON or OFF.
S3	Selects channel 001.
S4	Selects channel 002.

- mS .n1

S1	—
S2	—
S3	Channel up.
S4	Channel down.

- mS .n2

S1	—
S2	Turns the Monitor function ON or OFF.
S3	Channel up.
S4	Channel down.

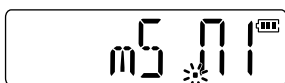

User remote control unit

The circuit illustrated below is for only reference.

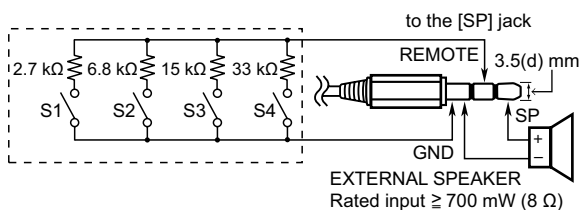

Voltage Indication

The voltage of the battery is displayed at power ON. This display can be turned ON or OFF. (Default: VLt.On)

- VLt.OF: The battery voltage display is skipped.
- VLt.On: The battery voltage is displayed at power ON.



Battery protection function

When the battery voltage decreases, the Battery Protection function automatically turns OFF the transceiver. Select the function option according to your battery type. (Default: Differs depending on the transceiver version)

- bAt.OF: Turns OFF the function. Select when you use the BP-263 battery case.
- bAt.nm: Select when you use the BP-264 Ni-MH battery pack.

- bAt.LI: Select when you use the BP-298/BP-299 Li-ion battery pack.

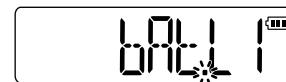

NOTE: BE SURE to select an appropriate option according to your battery type.

Auto low power

Turns the Automatic Low-power function ON or OFF. When the temperature goes below 0°C (+32°F), the function automatically sets the output power to low. In that case, the transmit power selections (High or Mid) are also disabled. (Default: ALP.OF)

- ALP.OF: The auto low power is OFF.
- ALP.On: The auto low power is ON.



NOTE: This item is activated when the Battery protection function is set to “bAt.nm” or “bAt.LI.”

CTCSS burst

The CTCSS burst function stops transmitting a subaudible tone before your transceiver stops transmitting RF, to eliminate noise. The CTCSS burst will be effective only when the other station uses the tone squelch function. (Default: Sqb.OF)

- Sqb.OF: The CTCSS burst is OFF.
- Sqb.On: The CTCSS burst is ON.



Memory CH Overwrite

Select whether or not to overwrite the original memory contents when charging the operating channel content. (Default: mOW.On)

- mOW.OF: The memory CH overwrite is OFF.
- mOW.On: The memory CH overwrite is ON.



NOTE: The original memory contents are the following contents.

- Output power
- Tone function
- Subaudible tone frequency
- Tone squelch frequency
- DTCS code
- DTCS polarity
- Mode

Section 9 PROGRAMMING

Programming operation.....	9-2
◇ Programming between two transceivers.....	9-2
◇ Programming using a PC.....	9-2

Programming operation

Programming allows you to quickly and easily transfer the programmed contents from one transceiver to another, or data between a personal computer and a transceiver, using the optional CS-G86 PROGRAMMING SOFTWARE.

◇ Programming between two transceivers

1. Turn OFF the transceivers, and then connect the master and Sub transceivers using the OPC-474 PROGRAMMING CABLE through their speaker jacks.
 - ① The Master transceiver is used to send data to the Sub transceiver.
2. While holding down [FUNC] and [▲], turn ON the master transceiver to enter the programming mode.
 - "CLOnE" is displayed.
3. Turn ON the Sub transceiver.
4. Push [PTT] on the Master transceiver.
 - "CL Out" is displayed on the Master transceiver's display, and the signal icon shows that data is being transferred to the Sub transceiver.
 - "CL In" is displayed on the Sub transceiver's display, and the signal icon shows that data is being received from the Master transceiver.
5. When the programming is finished, turn OFF both transceivers, and then turn ON the transceivers again to exit the programming mode.

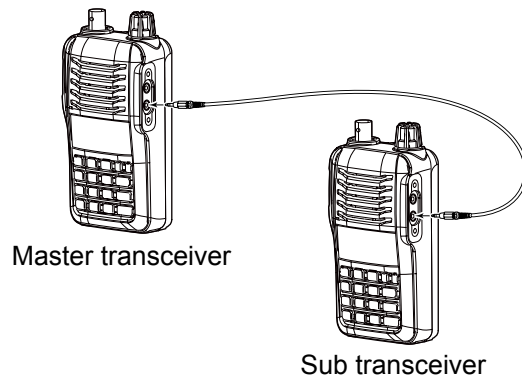

NOTE:

- **DO NOT** push [PTT] on the Sub transceiver during programming. This will cause an error.
- **DO NOT** disconnect the programming cable or turn OFF the transceivers during programming. This will cause an error.

◇ Programming using a PC

Data can be transferred to and from a PC, using the optional CS-G86 PROGRAMMING SOFTWARE and an OPC-478UC (USB type) PROGRAMMING CABLE. Consult the INSTRUCTIONS and the Help file that come with the programming software, for details.

CAUTION: BE SURE to turn OFF the power, before connecting or disconnecting optional equipment to or from the [SP MIC] jack.

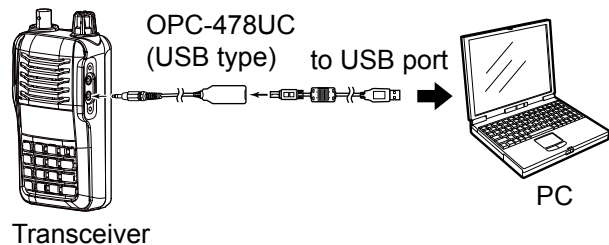

Section 10 TROUBLESHOOTING

Troubleshooting.....10-2

Troubleshooting

No power comes ON.

- The battery is exhausted.
→ Charge the battery pack, or replace the batteries. (pp. 2-2 ~ 11-3)
- The battery polarity is reversed.
→ Check the battery polarity. (p. 11-3)
- Bad connection of a battery pack or case.
→ Clean battery terminals. (p. 11-3)

No sound comes from the speaker.

- Volume level is too low.
→ Rotate [VOL] to adjust to the volume level.
- Squelch level is too high.
→ While holding down [MONI], push [▲] or [▼] several times to adjust the squelch level.
① Use [VOL] or [▲] or [▼], depending on the setting of the “Dial assignment” in the Initial Set mode.
- An external speaker or a programming cable is connected to the [SP] jack.
→ Check the external speaker connection or remove the programming cable.

Transmitting is impossible.

- The battery is exhausted.
→ Charge the battery pack, or replace the batteries. (pp. 2-2 ~ 11-3)
- The Lockout function is activated.
→ Wait to transmit until receiving an unmatched tone or a signal is stopped.

Transmitting using the VOX function is impossible.

- The VOX gain is set to OFF or too low.
→ Set the VOX gain to a suitable level. (p. 11-5)
- The microphone gain is too low.
→ Set the microphone gain to a suitable level. (p. 8-3)

No direct contact possible with other stations.

- A different tone or code is used for the tone or DTCS squelch.
→ Check the tone or DTCS code by the tone scan. (p. 6-5)

Operation channel cannot be set.

- The Key Lock function is activated.
→ Push [FUNC], and then hold down [r-O] for 1 second to cancel the Key Lock function.

A memory scan does not start.

- Only one or no memory channel has been programmed.
→ Program 2 or more memory channels.

The function display shows erroneous information.

- External factors have caused a fault.
→ Remove and reattach the battery pack or case. (p. 1-3)

Section 11 OPTIONS

Options	11-2
◇ Battery packs/Battery case	11-2
◇ Chargers	11-2
◇ DC cables	11-2
◇ Antennas	11-2
◇ Others	11-2
Optional battery case (BP-263)	11-3
VOX function	11-4
◇ Optional unit connection	11-4
◇ Turning the VOX function ON or OFF	11-4
◇ VOX-related settings.....	11-5

Options

◇ Battery packs/Battery case

- **BP-263** BATTERY CASE
- **BP-264** Ni-MH BATTERY PACK
- **BP-298/BP-299** Li-ion BATTERY PACK

Battery pack	Voltage	Capacity	Battery life*1	
BP-263	Battery case for AA (LR6) × 6 alkaline cells		—*2	
BP-264	7.2 V	1400 mAh (min.) 1420 mAh (typ.)	EXH	12.5 hours
			H	13 hours
BP-298	7.2 V	2100 mAh (min.) 2250 mAh (typ.)	EXH	19 hours
			H	20.5 hours
BP-299	7.2 V	3050 mAh (min.) 3150 mAh (typ.)	EXH	27 hours
			H	29 hours

*1 When the Power Save function is set to "P-S.16" (p. 8-6), and the operating time is calculated under the following ratio:
TX : RX : standby = 5 : 5 : 90 (3 seconds : 3 seconds : 54 seconds)

*2 The average operating life depends on the alkaline cells that are used.

Even when the transceiver power is OFF, a small amount of current still flows in the transceiver. Remove the battery pack or case when it will not be used for a long time. Otherwise, the battery pack or the batteries in the case will become exhausted.

◇ Chargers

- **BC-191** DESKTOP CHARGER
To rapidly charge the BP-264 Ni-MH BATTERY PACK.
- **BC-192** DESKTOP CHARGER
To regularly charge the BP-264 Ni-MH BATTERY PACK.
- **BC-240** DESKTOP CHARGER
To rapidly charge the BP-298/299 Li-ion BATTERY PACK.
- **BC-197** MULTI CHARGER
To rapidly charge the BP-264 Ni-MH BATTERY PACKS. The AD-120 CHARGER ADAPTERS are installed.
- **BC-214N** MULTI CHARGER
To rapidly charge the BP-298/299 Li-ion BATTERY PACKS. The AD-139 CHARGER ADAPTERS are installed.

① A power adapter may be supplied with the charger, depending on the charger version.

◇ DC cables

- **CP-23L** CIGARETTE LIGHTER CABLE
Use when charging the battery pack from a 12 V cigarette lighter socket.
(For the BC-191, BC-192, and BC-240)
- **OPC-515L/OPC-656** DC POWER CABLE
Use when charging battery packs using a 13.8 V DC power source instead of the power adapter.
OPC-515L: For the BC-191, BC-192, and BC-240
OPC-656: For the BC-197 and BC-214N

◇ Antennas

- **FA-B45V/FA-B57V** VHF ANTENNA
FA-B45V: 144 ~ 148 MHz
FA-B57V: 160 MHz

◇ Others

- **MB-124** BELT CLIP
- **MB-130** CHARGER BRACKET
Mounts the BC-191, BC-192, and BC-240 BATTERY CHARGERS on a variety of places in a vehicle.
- **HM-158LA/HM-159LA/HM-168LWP** SPEAKER MICROPHONE
Combination speaker microphone that provides convenient operation while the transceiver is hanging on your belt.
① Adjust the microphone gain before use.
- **HM-153LA/HM-166LA** EARPHONE MICROPHONE
Ideal for hands-free operation. Clip the HM-153LA or HM-166LA (with integrated PTT switch) to your lapel or breast pocket.
① Adjust the microphone gain before use.
- **HS-94/HS-95/HS-97** HEADSET
+VS-4LA PTT SWITCH CABLE/**OPC-2004LA** ADAPTER CABLE
HS-94: Ear-hook type
HS-95: Neck-arm type
HS-97: Throat microphone
VS-4LA: To connect to headsets
OPC-2004LA: To connect to headsets for VOX operation.
① Adjust both the microphone and VOX gain before use.
- **HS-94LWP/HS-95LWP** HEADSET
HS-94LWP: Ear-hook type
HS-95LWP: Neck-arm type
① Adjust both the microphone and VOX gain before use.
- **CS-G86** PROGRAMMING SOFTWARE
+OPC-478UC PROGRAMMING CABLE
Provides quick and easy programming of such settings as memory channels and Set modes contents.
- **OPC-474** PROGRAMMING CABLE
For transceiver-to-transceiver programming.

Some options may not be available in some countries. Ask your dealer for details.

Optional battery case (BP-263)

When using the battery case (BP-263), install 6 × AA (LR6) size alkaline batteries, as described below.

1. Remove the battery case, if it is attached.
① The procedure of removing the battery case is same as the battery pack. (p. 1-3)
2. Install 6 × AA (LR6) size alkaline batteries.
① Install only alkaline batteries.
① Be sure to observe the correct polarity.
3. Attach the battery case.
① The procedure of attaching the battery case is same as the battery pack. (p. 1-3)

⚠ WARNING!

- Never incinerate used battery cells since the internal battery gas may cause them to rupture.
- Never expose a detached battery case to water. If the battery case gets wet, be sure to wipe it dry before using it.

CAUTION:

- When installing batteries, make sure they are all the same brand, type and capacity. Also, do not mix new and old batteries together.
- Keep battery terminals clean. It's a good idea to occasionally clean them.
- Never use batteries whose insulated covering is damaged.

CAUTION: When the battery case is attached, the Battery Protection function must be turned OFF in the Initial Set mode. (p. 8-7)

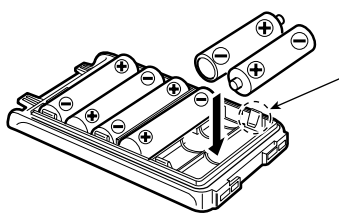

BE CAREFUL! The negative terminals of the battery case protrude from the body, so pay attention not to injure your fingers when inserting the batteries.

VOX function

The transceiver has a VOX function, which allows hands-free operation.

An optional HS-94, HS-95, or HS-97 HEADSET and the VS-4LA PTT SWITCH CABLE or OPC-2004LA ADAPTER CABLE are also required for operation.

What is VOX?

The VOX (voice operated transmission) function starts transmission when you speak into the microphone, without pushing [PTT], and then automatically returns to reception when you stop speaking.

Optional unit connection

1. Hold down [⏻] for 1 second to turn OFF the power.
2. Remove the jack cover. (p. 1-3)
3. Connect the optional HS-94, HS-95, or HS-97, and VS-4LA or OPC-2004LA.

CAUTION: DO NOT use the transceiver without the connector cover or the optional microphone attached. The transceiver meets IP54 requirements for dust protection and splash resistance only when the connector cover or the optional microphone is attached.

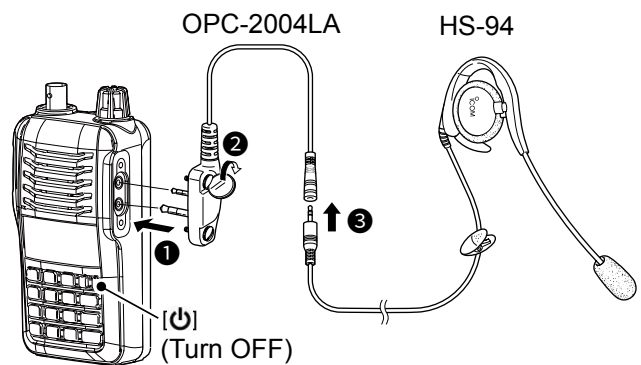

Turning the VOX function ON or OFF

1. Connect an optional headset and plug adapter cable to the transceiver, and then turn ON the power.
2. Push [FUNC], and then push [VOX] to turn the VOX function ON or OFF.
 - "VOX" is displayed when the VOX function is ON.

NOTE:

- When using the VOX function, adjust the microphone gain and the VOX-related settings (p. 11-5) to suit your operating environment (including your headset performance).
- Set the microphone gain before setting the VOX gain in the Set mode. (p. 8-3)
We recommend setting the microphone gain to 3.

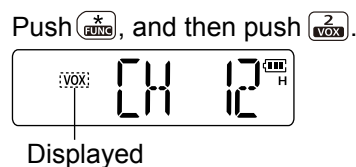

VOX function

◇ VOX-related settings

The VOX gain, VOX delay, and VOX time-out timer are set in the Set mode.

1. Connect an optional headset and plug adapter cable to the transceiver, and then turn ON the power.
2. Push [FUNC], and then push [VOX] to turn ON the VOX function.
3. Push [FUNC], and then push [SET] to enter the Set mode.
4. Push [▲] or [▼] to select the VOX gain (VOX), VOX delay (VXd), or the VOX time-out timer (Vto) item.
5. Rotate [VOL] to select an option.
6. Push [# ENT] to exit the Set mode.

The VOX function is not activated while in the Set mode.

VOX gain

The VOX gain level can be adjusted between 1 (minimum) and 10 (maximum), or turned OFF. Higher values make the VOX function more sensitive to your voice. (Default: VOX.05)

- While speaking into the headset microphone, adjust the VOX gain until “On” continuously is displayed on the display.

If “On” is intermittent, be sure the VOX delay is set long enough to allow normal pauses in speech, but keep the VOX ON until you finish speaking.

CONVENIENT!

While transmitting using the VOX function, you can adjust the VOX gain simply by rotating [VOL].



VOX delay

Set the VOX delay to between 0.5 and 3.0 seconds (in 0.5 seconds steps). The VOX delay is the amount of time the transmitter stays ON after you stop speaking. (Default: VXd.10)

VOX time-out timer

Set the VOX time-out timer to between 1, 2, 3, 4, 5, 10 and 15 minutes to prevent accidental prolonged transmission for the VOX function. To turn OFF the function, select “Vto.OF.” (Default: 3)

The VOX time-out timer must be set shorter than the time-out timer, otherwise the VOX time-out timer will not function.

Push , and then push .



Displayed

The “VOX gain” item in the Set mode

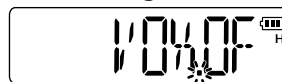

The VOX function is turned OFF.



The VOX gain is set to 10 (max.).



Displayed

The “VOX delay” item in the Set mode

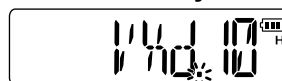

The VOX delay is set to 1 second.

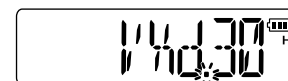

The VOX delay is set to 3 seconds.

The “VOX time-out timer” item in the Set mode



The VOX time-out timer is set to 3 minutes.



VOX time-out timer is set to 15 minutes (maximum).

Count on us!

