



INSTRUCTION MANUAL

MF/HF MARINE TRANSCEIVER

IC-M801E



FOREWORD

Thank you for purchasing this Icom product. The IC-M801E MF/HF MARINE TRANSCEIVER is designed and built with Icom's superior technology and craftsmanship. With proper care, this product should provide you with years of trouble-free operation.

We want to take a couple of moments of your time to thank you for making the IC-M801E your radio of choice, and hope you agree with Icom's philosophy of "technology first." Many hours of research and development went into the design of your IC-M801E.

◇ FEATURES

- Standard 4×8" remote controller
- Built-in DSC meets ITU Class E requirement
- 12 and 24 V DC versions are available
- PC connection capability for remote control

PRECAUTIONS

⚠ **WARNING HIGH VOLTAGE! NEVER** attach an antenna or internal antenna connector during transmission. This may result in an electrical shock or burn.

⚠ **WARNING! NEVER** connect the transceiver to an AC outlet directly. This may pose a fire hazard or result in an electric shock.

⚠ **WARNING! NEVER** mount the transceiver main unit overhead. The weight of the unit is approximately 8.5 kg, but its apparent weight will increase several fold due to wave shocks or vibration. The unit must be mounted on a flat hard surface only.

⚠ **NEVER** connect a power source of more than 15.6 V DC or 31.2 V DC (depending on the transceiver version). This connection could cause a fire or ruin the transceiver.

⚠ **NEVER** place the transceiver where normal operation of the ship or vehicle may be hindered or where it could cause bodily injury.

⚠ **NEVER** let metal, wire or other objects touch any internal part or connectors on the rear panel of the transceiver. This may result in an electric shock.

DO NOT use chemical agents such as benzine or alcohol when cleaning, as they can damage the transceiver surface.

IMPORTANT

READ THIS INSTRUCTION MANUAL CAREFULLY before attempting to operate the transceiver.

SAVE THIS INSTRUCTION MANUAL. This manual contains important safety and operating instructions for the IC-M801E.

EXPLICIT DEFINITIONS

WORD	DEFINITION
⚠ WARNING	Personal injury, fire hazard or electric shock may occur.
CAUTION	Equipment damage may occur.
NOTE	If disregarded, inconvenience only. No risk or personal injury, fire or electric shock.

During maritime mobile operation, **KEEP** the transceiver and handset or microphone **as far away** as possible (at least 1 m) from the magnetic navigation **compass** to prevent erroneous indications.

Use Icom handset or microphones only (supplied or optional). Other manufacturer's handset or microphones have different pin assignments, and connection to the IC-M801E may damage the transceiver.

AVOID using or placing the transceiver in areas with temperatures below -15°C or above $+55^{\circ}\text{C}$.

AVOID placing the transceiver in excessively dusty environments or in direct sunlight.

AVOID placing the transceiver against walls or putting anything on top of the transceiver. This will obstruct heat dissipation.

Place the unit in a secure place to avoid inadvertent use by children.

BE CAREFUL! The transceiver main unit will become hot when operating the transceiver continuously for long periods.

Icom, Icom Inc. and the  are registered trademarks of Icom Incorporated (Japan) in the United States, the United Kingdom, Germany, France, Spain, Russia and/or other countries.

IBM is a registered trademark of International Business Machines.

IN CASE OF EMERGENCY

When your ship requires assistance, contact other ships and the Coast Guard by sending a distress call using digital selective calling on an emergency frequency.

When immediate help is needed

- ① Push and hold [DISTRESS] for 5 sec. until the short beeps become one long beep, to send the distress call.
- ② After 8291 kHz is automatically selected (after an acknowledgement call is received), push and hold the PTT switch on the handset or microphone and send the following information.
 1. "MAY DAY, MAY DAY, MAY DAY."
 2. "THIS IS....." (name of ship)
 3. "LOCATED AT" (ship's position)
 4. Give the reason for the distress call.
 5. Explain what assistance you need.
 6. Give additional information:
 - Ship type
 - Ship length
 - Ship color
 - Number of people on-board

When potential problems exist

- ① Push [DSC] to select DSC watch mode, if necessary.
- ② Push [MODE SET] to select DSC menu, rotate [CH] to select "Geographical" then push [ENT].
- ③ Follow the guidance displayed on the LCD (bottom line), to set up the category, area, traffic and calling frequencies with [CH], [ENT] and keypad.
- ④ Push and hold [CALL] for 1 sec. until the short beeps become one long beep.
- ⑤ Transmit the appropriate information using voice.
 - DSC equipped ships may monitor your transmission.

TABLE OF CONTENTS

FOREWORD.....	i	6 DSC PREPARATION	14–15	■ Telephone number input	40
IMPORTANT	i	■ MMSI code programming	14	■ Memory reading/deleting	41
EXPLICIT DEFINITIONS	i	■ Position and time programming	15	■ Printing out the DSC memory contents	41
PRECAUTIONS	i	7 CALL PROCEDURE	16–28	11 SET MODE	42–47
IN CASE OF EMERGENCY	ii	■ Distress call	16	■ Quick set mode	42
TABLE OF CONTENTS	ii	■ Individual call	20	■ Initial set mode	43
QUICK REFERENCE.....	I–V	■ Group call	23	12 CONNECTION AND INSTALLATION	48–60
■ How to set a Channel/Group	I	■ Geographical call	24	■ Supplied accessories	48
■ Audio output/squelch adjustment	II	■ Semi/Auto (telephone) call	26	■ Basic connections	49
■ Basic voice transmission and reception	III	■ Test call	28	■ Advanced connections	50
■ Receiving a DSC.....	IV	8 WHEN RECEIVING A CALL	29–36	■ Ground connection	51
■ Transmitting a distress call.....	IV	■ To receive a DSC call	29	■ Power source	52
1 OPERATING RULES AND GUIDELINES.....	1	■ Received information	30	■ Antenna	52
2 PANEL DESCRIPTION	2–7	■ Deleting a memory	30	■ Mounting	53
■ Controller (RC-25E)	2	■ Distress call	31	■ Using the optional MB-108	55
■ Main unit.....	4	■ Distress relay call	33	■ Using the optional MB-75	56
■ Handset (HS-98)	5	■ Semi/Auto (telephone) call	34	■ Transceiver dimensions	57
■ LCD screen	6	■ Group call	35	■ Fuse replacement	58
3 SELECTING A CHANNEL/FREQUENCY	8–9	■ Geographical area call	35	■ Connector information	59
■ Selecting a channel	8	■ Individual call	36	13 FREQUENCY PROGRAMMING ..	61–62
4 RECEIVE AND TRANSMIT	10–12	9 MEMORY OPERATION	37	■ Frequency selection	61
■ Basic voice transmit and receive	10	■ Memory description	37	■ Programming a frequency	62
■ Function for transmit	10	■ Memory writing	37	14 SPECIFICATIONS	63
■ Functions for receive	11	■ Memory reading/transmitting/deleting	37	15 OPTIONS	64
■ FSK operation	12	10 DSC MENU OPERATION	38–41	16 TEMPLATE	65–68
5 CHANNEL NAME PROGRAMMING ..	13	■ General	38	■ Remote controller (RC-25E)	65
		■ ID input	38	■ Speaker (SP-24E)	67
		■ Frequency input	39	ABOUT CE	69
		■ Verifying self-ID	40		
		■ Self testing	40		

QUICK REFERENCE

■ How to set a Channel/Group

The IC-M801E has up to 160 user-programmable, 249 ITU SSB duplex, 124 ITU SSB simplex and 662 ITU FSK duplex channels.

◆ Using the group and channel selectors

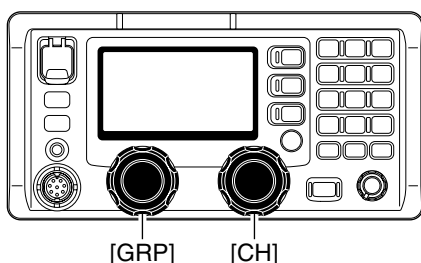

- ① Rotate [GRP] to select the desired group.
 - Available groups are shown in the list below.
 - During user-programmable channel group use, the channels change in 20-channel steps. See details on p. 8.
 - Example; When starting the user-programmable Ch. 1.
1 ⇔ 21 ⇔ 41...141 ⇔ 401 ⇔ 4-1 ⇔ 601.....C2-1...1
- ② Rotate [CH] to select the desired channel.
 - Available channels are shown in the list below.
 - Pushing [▲]/[▼] on the optional hand microphone, HM-135, also selects a channel.

◆ Using the keypad

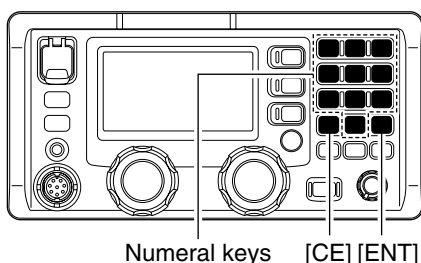

• When selecting an user-programmable channel

- ➔ Push the appropriate numeral keys to set the 1, 2 or 3-digit channel number, then push [ENT].
- Pushing [CE] clears input digits and retrieves the channel.

Example; When selecting Ch. 1.
Push [1 NB] then push [ENT].

Example; When selecting Ch. 35.

Push [3 SCAN], [5 AGC^x] then push [ENT].

Example; When selecting Ch. 128.

Push [1 NB], [2 SQL], [8 PRN] then push [ENT].

• When selecting an ITU duplex channel

- ➔ Push the appropriate numeral keys to set the 3, 4 or 5-digit channel number, then push [ENT].
- Pushing [CE] clears input digits and retrieves the channel.

Example; When selecting Ch. 401.

Push [4 SP^x], [0 DIM], [1 NB] then push [ENT].

Example; When selecting Ch. 2505.

Push [2 SQL], [5 AGC^x], [0 DIM], [5 AGC^x] then push [ENT].

• When selecting an ITU simplex channel

- ➔ Push the appropriate numeral keys to set the 5 or 6-digit channel number, then push [ENT].
- Push [0 DIM] 3 times to enter “-” (dash)."
- Pushing [CE] clears input digits and retrieves the channel.

Example; When selecting Ch. 4-1.

Push [4 SP^x], [0 DIM], [0 DIM], [0 DIM], [1 NB] then push [ENT].

- After pushing [0 DIM] 3 times, “-” appears.

Example; When selecting Ch. 25-2.

Push [2 SQL], [5 AGC^x], [0 DIM], [0 DIM], [0 DIM], [2 SQL] then push [ENT].

- After pushing [0 DIM] 3 times, “-” appears.

• Available channel groups and channels

Channel No.	Description	Channel No.	Description	Channel No.	Description
1 to 160	User Ch.* ¹	1201 to 1241	12 MHz ITU duplex Ch.	22-1 to 22-9	22 MHz ITU simplex Ch.
401 to 427	4 MHz ITU duplex Ch.	12-1 to 12-9	12 MHz ITU simplex Ch.	2501 to 2510	25 MHz ITU duplex Ch.
4-1 to 4-9	4 MHz ITU simplex Ch.	1601 to 1656	16 MHz ITU duplex Ch.	25-1 to 25-9	25 MHz ITU simplex Ch.
601 to 608	6 MHz ITU duplex Ch.	16-1 to 16-9	16 MHz ITU simplex Ch.	C1-1 to C1-21	C1 channels
6-1 to 6-9	6 MHz ITU simplex Ch.	1801 to 1815	18 MHz ITU duplex Ch.	C2-1 to C2-31	C2 channels
801 to 832	8 MHz ITU duplex Ch.	18-1 to 18-9	18 MHz ITU simplex Ch.	4001 to 25040	ITU FSK duplex Ch.* ²
8-1 to 8-9	8 MHz ITU simplex Ch.	2201 to 2253	22 MHz ITU duplex Ch.		

*¹[GRP] changes in 20 channels steps. *²SITOR use— no group separation.

■ Audio output/squelch adjustment

◆ Audio output level

➔ Rotate [VOL] to adjust audio output level.

NOTE: Connect the handset/microphone and make sure that no “SP” and “SQL” indicators are displayed during audio level adjustment, otherwise, audio may not be output.

When either or both indicators are displayed, perform the following operations;

- When “SP” is displayed, push [F] then [4 SP*].
- When “SQL” is displayed, push [F] then [2 SQL].

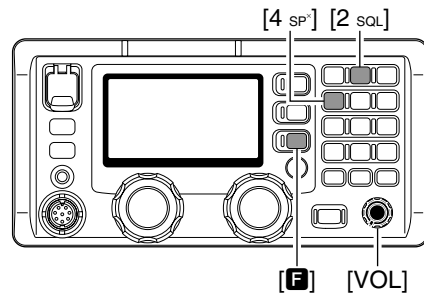

◆ Squelch function

➔ Push [F] then [2 SQL] to turn the squelch function ON and OFF.

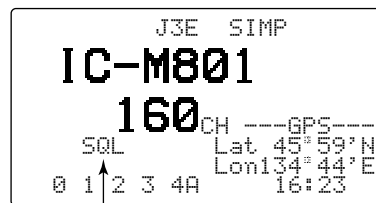
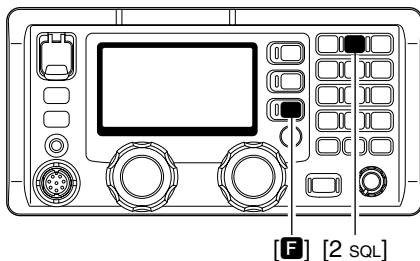

“SQL” appears when the squelch function is ON.

• Squelch level adjustment

- ① Push [F] then [2 SQL] to turn the squelch function ON.
 - Select the desired frequency/channel in advance, if desired.
- ② Push [F] then [MODE SET] to enter quick set mode.

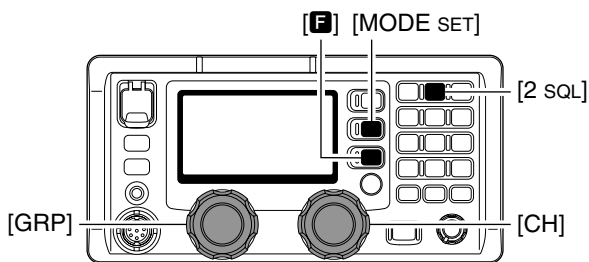

- ③ Rotate [GRP] to select the “S-SQL LEVEL” item.
- ④ Rotate [CH] to adjust the squelch level.
 - Adjust the level within 1–100 range.

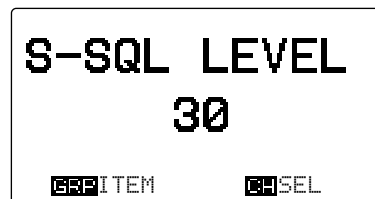

- ⑤ Push [MODE SET] to exit quick set mode.

• Voice squelch function

The voice squelch function detects voice components in the received signal and opens the squelch only when voice components are included in the signal.

- ① While pushing [MODE SET] turn the power ON to enter initial set mode.

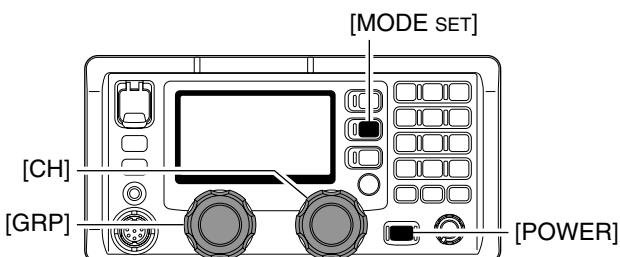

- ② Rotate [GRP] to select the “VOICE SQL” item.
- ③ Rotate [CH] to select the voice squelch function ON and OFF.

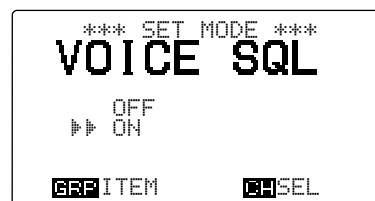

- ④ Turn the power OFF then ON again to exit initial set mode.

■ Basic voice transmission and reception

◆ Receiving a signal

- ① Select the desired channel via [GRP] and [CH], or keypad.
 - Turn ON/OFF the squelch function or adjust the squelch level as desired.
- ② When a signal is received, "RX" indicator appears and audio is output from the connected speaker.
 - Rotating [VOL] to adjust the audio output level at this moment is recommended.
 - S-meter shows the received signal strength.
- ③ Use the following functions, if desired:

• Noise blanker

Push [F] then [1 NB] to turn the noise blanker ON and OFF.

- "NB" appears when the noise blanker is activated.
- See page 42 for the noise blanker level adjustment.

• AGC (Automatic Gain Control) OFF function

Push [F] then [5 AGC*] to turn the AGC OFF function ON and OFF.

- "AGC" appears when the AGC-OFF function is activated (deactivating AGC).

• RF gain level

Push [F], [6 RF-G] to enter the RF gain adjustment mode, then rotate [CH] to adjust the gain.

- Adjust the gain within 0 (low sensitivity) to 9 (maximum sensitivity) range.
- Push [MODE SET] to exit the adjustment mode.

• Clarity

Push [F], [RX CLAR] to switch the clarity function ON and OFF, then rotate [CH] for critical tuning.

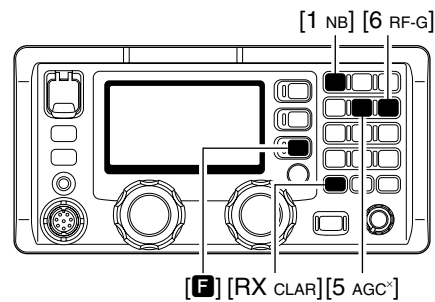

◆ Transmitting in voice

- ① Select the desired channel via [GRP] and [CH], or keypad.
- ② Push [F], then push and hold [TX TXF] for a while to monitor the transmit frequency of the selected channel.
 - The transmit frequency is displayed and "TX" blinks.
 - When the channel is busy, wait until it becomes clear, or change the channel.

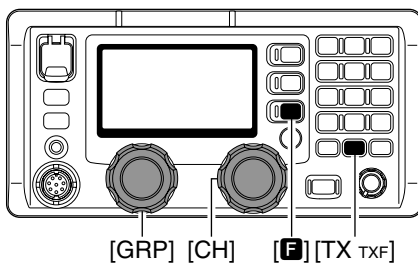

- ③ When the optional AT-141 is connected, push [TUNE THRU] to start manual tuning.
 - "TUNE" appears when the antenna is tuned.
 - "TUNE" blinks when a tuning error has occurred.
 - Automatic tuning function is also available.

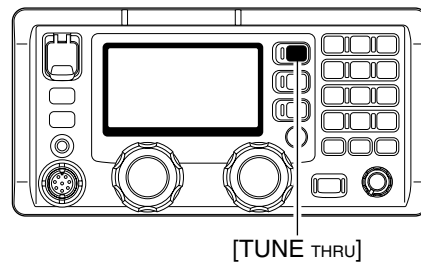

- ④ Push and hold [PTT] on the handset or microphone to transmit.
 - "TX" appears.
 - If "SUR" appears during transmit, check your antenna system.
- ⑤ Speak into the handset or microphone at your normal voice level.
- ⑥ Release [PTT] to return to receive.
 - "TX" disappears.

■ Receiving a DSC

- ➔ For waiting for a DSC call, such as an individual or group call on the desired frequencies, push [DSC] to enter DSC watching mode.
 - Monitoring the frequencies, 2187.5, 4207.5, 6312.0, 8414.5, 12577.0 and 16804.5 kHz, for distress, urgency, etc., no operation is necessary with the transceiver. These frequencies are monitored at all times.

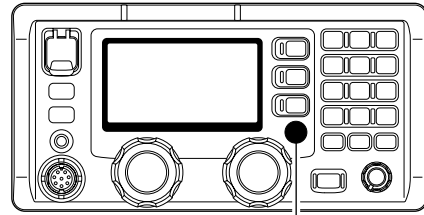

[DSC]

■ Transmitting a distress call

◇ Simple distress call

- ➔ Lift up the distress switch cover, then push and hold [DISTRESS] for 5 sec.
 - After 5 sec., a distress call is sent.

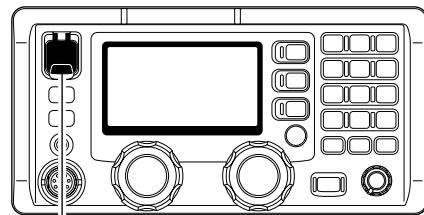

[DISTRESS]

◆ Regular distress call

① Push [DSC] to enter DSC watch mode.

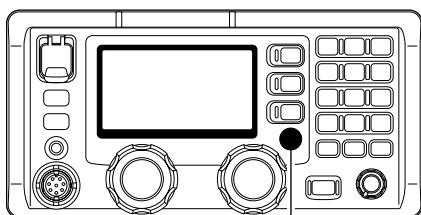

[DSC]

② Push [MODE SET] to enter DSC menu.

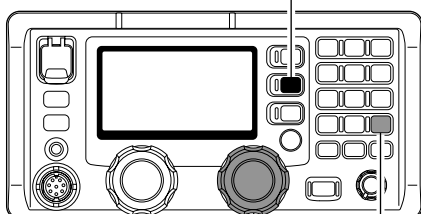

[MODE SET]

[CH] [ENT]

③ Rotate [CH] to select "Distress" then push [ENT].

```

***** DSC MENU *****
----- Select -----
Position
Individual
Group
Geographical
▶Distress
Distress RLY
Semi/Auto
Test
RX memory
TX memory
Set up
Self test
Exit
[CH]SEL [ENT]OK
    
```

④ Rotate [CH] to select the desired nature then push [ENT].

```

***** Distress *****
----- Nature -----
▶Undesignated
Fire,Explosion
Flooding
Collision
Grounding
Capsizing
Sinking
Disable adrift
Abandoning ship
Piracy attack
Man overboard
[CH]SEL [ENT]OK
    
```

⑤ Verify your position and the UTC time, then push [ENT].

- When no NMEA0183 ver. 3.01 data is applied to [GPS], your position and UTC time should be input in this step.
- Use the keypad and [CH] when changing your position or the time.
- Move the cursor with [CH] rotation.
- [3 SCAN], [6 RF-G], [7] and [9] is used for the 'East,' 'North,' 'South' and 'West' selection.

```

***** Distress *****
--- Position & time ---
Latitude 34.343N
Longitude 105.34.343E
UTC 12:34
[CH]Null [CH]↔ [ENT]OK
    
```

⑥ Rotate [CH] to select the DSC calling frequencies, then push [ENT].

- After pushing [ENT], return to DSC menu as shown in step ③.

```

***** Distress *****
----- Attempt -----
▶Single; six frequency
Single: 2187.5kHz
Single: 4207.5kHz
Single: 6312.0kHz
Single: 8414.5kHz
Single: 12577.0kHz
Single: 16804.5kHz
[CH]SEL [ENT]OK
    
```

⑦ Lift up the distress switch cover, then push and hold [DISTRESS] for 5 sec.

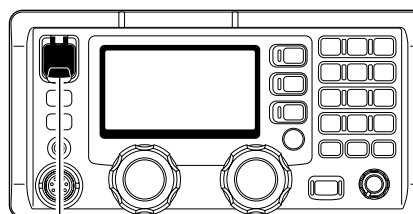

[DISTRESS]

Before transmitting, monitor the channel you wish to use so as to avoid interrupting transmissions already in progress.

•CALL PROCEDURE

Calls must be properly identified and the time limit must be respected.

- ① Give your call sign each time you call another ship or coast guard station. If you have no call sign, identify the station by giving your ship name and the name of the licensee.
- ② Give your call sign at the end of each transmission that lasts more than 3 min.
- ③ You must break and give your call sign at least once every 15 min. during long ship-to-shore calls.
- ④ Keep your unanswered calls short, less than 30 sec. Do not repeat a call for 2 min.
- ⑤ Unnecessary transmissions are not allowed.

•PRIORITIES

- ① Read all rules and regulations pertaining to priorities and keep an up-to-date copy handy. Safety and distress calls take priority over all others.
- ② False or fraudulent distress signals are prohibited and punishable by law.

•PRIVACY

- ① Information overheard but not intended for you, cannot lawfully be used in any way.
- ② Indecent or profane language is prohibited.

•LOGS

- ① All distress, emergency and safety calls must be recorded in complete details. Log data activity is usually recorded in 24 hour time. Universal Time Coordinated (UTC) is frequently used.
- ② Adjustments, repairs, channel frequency changes and authorized modifications affecting electrical operation of the equipment must be kept in the maintenance log; entries must be signed by the authorized licensed technician performing or supervising the work.

•RADIO LICENSES

(1) SHIP STATION LICENSE

You must have a current radio station license before using the transceiver. It is unlawful to operate a ship station which is not licensed.

Inquire through your dealer or the appropriate government agency for a Ship-Radiotelephone license application. This government-issued license states the call sign which is your craft's identification for radio purposes.

(2) OPERATOR'S LICENSE

A Restricted Radiotelephone Operator Permit is the license most often held by small ship radio operators when a radio is not required for safety purposes.

The Restricted Radiotelephone Operator Permit must be posted or kept with the operator. Only a licensed radio operator may operate the transceiver.

However, non-licensed individuals may talk over a transceiver if a licensed operator starts, supervises, and ends the call and makes the necessary log entries.

Keep a copy of the current government rules and regulation handy.

■ Controller (RC-25E)

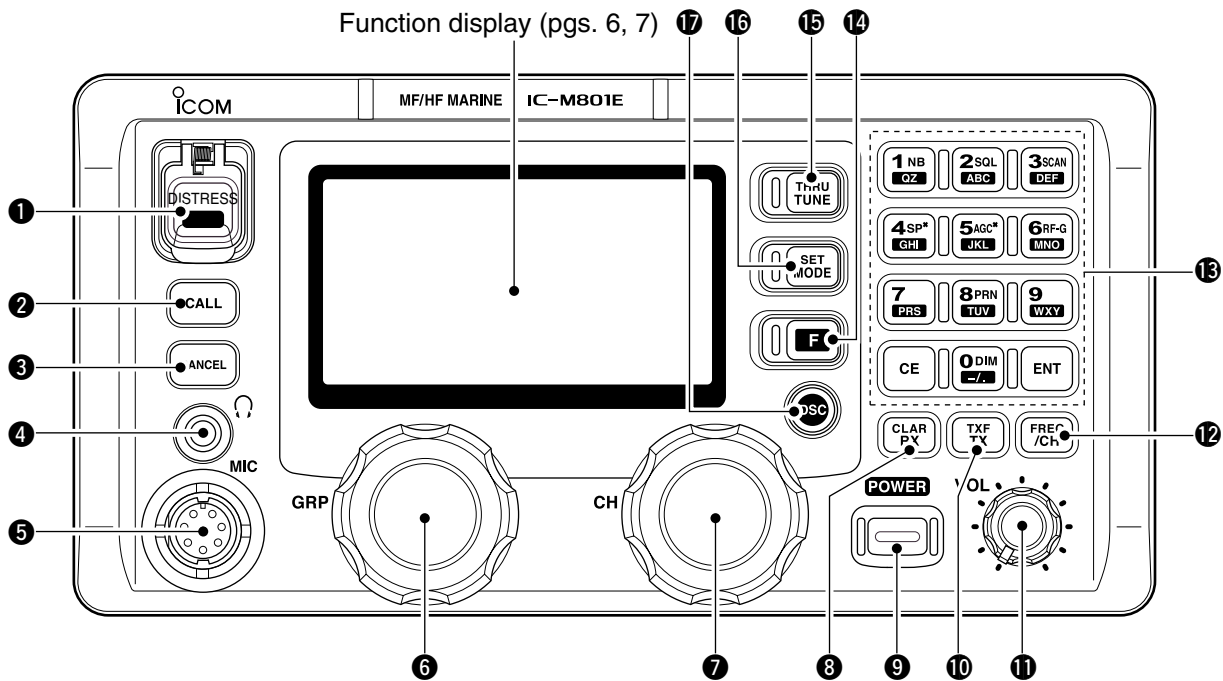

1 DISTRESS SWITCH [DISTRESS] (p. 17)

Push for 5 sec. (approx.) to make a distress call.

2 CALL SWITCH [CALL]

Push for 1 sec. to start calling after DSC contents are setup.

3 CANCEL SWITCH [CANCEL]

Cancels a distress or DSC repeat call.

4 HEADPHONE JACK []

Accepts headphones.

- Output power: 2.5 mW with a 16 Ω load (stereo/monaural)

5 MICROPHONE CONNECTOR [MIC]

Accepts the supplied or optional microphone.

- See p. 64 for appropriate microphones.
- See p. 59 for microphone connector information.

6 GROUP SELECTOR [GRP]

- ➔ Selects groups in 20 channel steps and ITU marine channel groups. (p. 8)
- ➔ Selects items during quick/initial set mode, etc.

7 CHANNEL SELECTOR [CH]

- ➔ Selects an operating channel within the selected channel group such as ITU channels. (p. 8)
 - User channels can be selected from 1 to 160 (max.) in sequence regardless of the channel group.
- ➔ Changes setting or value of the selected item during quick/initial set mode, etc.

8 RX/CLARITY SWITCH [RX CLAR]

➔ After pushing [F], turns the clarity function ON and OFF. (p. 12)

- [CH] is used for clarity control.

➔ During DSC watch mode, enters RX memory select screen. (p. 30)

- [CH] is used for distress and other call selection.

9 POWER SWITCH [POWER]

➔ Push to turn the power ON.

➔ Push for 1 sec. to turn the power OFF.

10 TX/TRANSMIT FREQUENCY SWITCH [TX TXF]

➔ After pushing [F], displays the transmit frequency, and opens the squelch. Checks and monitors the transmit frequency while holding. (p. 10)

➔ During DSC watch mode, enters TX memory select screen. (p. 37)

- [CH] is used for memory selection.

11 VOLUME CONTROL [VOL]

Adjusts the audio output level.

• Audio does not come from the speaker when:

- The speaker OFF switch is turned ON.
- The squelch function is turned ON and no signal is being received.
- Pick the handset up with speaker switch “” position. (p. 5)
- During DSC watch mode.

12 FREQUENCY/CHANNEL SWITCH [FREQ/CH]

- ➔ Selects indication type: (p. 8)
 - When channel comment indication is ON; switches channel comment indication ON and OFF.
 - When channel comment indication is OFF; switches transmit frequency indication ON and OFF.
- ➔ After pushing [F], enters channel name programming mode, when channel comment indication is ON. (p. 13)

13 KEYPAD

- 1 NB QZ**
 - ➔ Inputs numeral "1" for channel number input, etc.
 - ➔ Inputs "1," "Q," "Z," "q," "z" or space for channel comment input.
 - ➔ After pushing [F], turns the noise blanker function ON and OFF. (p. 11)
- 2 SQL ABC**
 - ➔ Inputs numeral "2" for channel number input, etc.
 - ➔ Inputs "2," "A," "B," "C," "a," "b" or "c" for channel comment input.
 - ➔ After pushing [F], turns the squelch function ON and OFF. (p. 11)
- 3 SCAN DEF**
 - ➔ Inputs numeral "3" for channel number input, etc.
 - ➔ Inputs "3," "D," "E," "F," "d," "e" or "f" for channel comment input.
 - ➔ After pushing [F], starts and stops the scan function. (p. 9)
- 4 SP* GHI**
 - ➔ Inputs numeral "4" for channel number input, etc.
 - ➔ Inputs "4," "G," "H," "I," "g," "h" or "i" for channel comment input.
 - ➔ After pushing [F], turns the external speaker output ON and OFF. (p. 10)
- 5 AGC* JKL**
 - ➔ Inputs numeral "5" for channel number input, etc.
 - ➔ Inputs "5," "J," "K," "L," "j," "k" or "l" for channel comment input.
 - ➔ After pushing [F], turns the AGC OFF function ON and OFF. (p. 11)
- 6 RF-G MNO**
 - ➔ Inputs numeral "6" for channel number input, etc.
 - ➔ Inputs "6," "M," "N," "O," "m," "n" or "o" for channel comment input.
 - ➔ After pushing [F], enters the RF gain adjustment mode. (p. 11)
- 7 PRS**
 - ➔ Inputs numeral "7" for channel number input, etc.
 - ➔ Inputs "7," "P," "R," "S," "p," "r" or "s" for channel comment input.



- ➔ Inputs numeral "8" for channel number input, etc.
- ➔ Inputs "8," "T," "U," "V," "t," "u" or "v" for channel comment input.
- ➔ After pushing [F], push for 1 sec. to print out the DSC contents, etc. (p. 41)



- ➔ Inputs numeral "9" for channel number input, etc.
- ➔ Inputs "9," "W," "X," "Y," "w," "x" or "y" for channel comment input.



- ➔ Inputs numeral "0" for channel number input, etc.
- ➔ Inputs "0" and symbols (., °, <, >, *, +, -, /, <, =, >, @) for channel comment input.
- ➔ After pushing [F], selects LCD backlight brightness.



- ➔ Fixes input of channel number and channel comment, etc.
- ➔ When pushed for 1 sec., stores programmed frequency, operating mode and memory comment into a channel.



- ➔ Clears entered digits and retrieves the previous frequency, channel or channel names during setting.

14 FUNCTION SWITCH [F]

- ➔ After pushing, activates the secondary functions.
- "F" appears when a secondary function can be accessed.

15 TUNE/THROUGH SWITCH [TUNE THRU]

- ➔ Starts tuning when the optional AT-141 HF AUTOMATIC ANTENNA TUNER is connected.
 - "TUNE" appears when tuned.
 - When the tuner cannot tune the antenna, the tuning circuit is bypassed automatically after 15 sec.
- ➔ After pushing [F], bypasses the connected antenna tuner. (p. 12)
 - "THRU" appears instead of "TUNE" indication.

16 MODE/SET SWITCH [MODE SET]

- ➔ Push to select an operating mode.
 - J3E (USB), H3E (AM), LSB, J2B (AFSK), F1B (FSK), and A1A (CW) modes are available, depending on version or countries.
- ➔ After pushing [F], enters quick set mode. (p. 42)
- ➔ During DSC watch mode, enters DSC menu.

17 DSC SWITCH [DSC] (p. 29)

- ➔ Switches DSC watch mode and voice communication mode when pushed.

■ Main unit

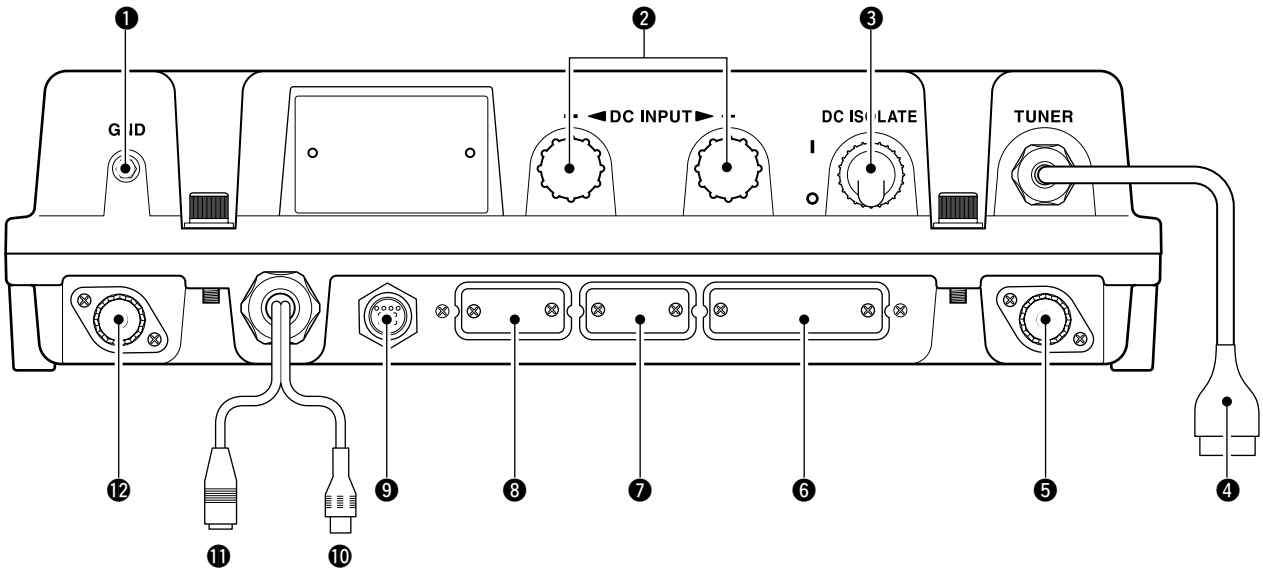

- 1 GROUND TERMINAL**
IMPORTANT! Connects a ship's ground. See page 51 for details.
- 2 DC POWER TERMINALS** (pgs. 49, 52)
Accepts 12 V DC or 24 V DC through the supplied DC power cables.
Red terminal is for positive and black terminal is for negative connection.
- 3 DC ISOLATE SWITCH [DC ISOLATE]** (p. 49)
Turns the transceiver's main power ON and OFF.
- 4 TUNER CONTROL SOCKET** (pgs. 49, 52)
Connects a control cable to an optional antenna tuner.
A female connector kit is supplied for external antenna tuner connection.
- 5 ANTENNA CONNECTOR 1** (pgs. 49, 52)
Connects a 50 Ω HF band antenna via a 50 Ω matched coaxial cable with a PL-259 plug for both transmit and receive operation.
- 6 PRINTER CONNECTOR** (pgs. 50, 60)
Connects an IBM® centronics or compatible printer to print out received DSC information automatically or manually.
- 7 REMOTE CONNECTOR [REMOTE]** (pgs. 50, 59)
Connects to a PC via an RS-232C cable (D-sub 9-pin) for remote control in the NMEA or RS-232C format.

- 8 MODEM CONNECTOR [AF/MOD]** (pgs. 50, 59)
Connects to an NBDP (Narrow Band Direct Printing) or FAX system via a D-sub 9-pin cable.
- 9 CONTROLLER CONNECTOR [CONTROLLER]** (p. 49)
Connects the supplied remote controller, RC-25E.
- 10 GPS CONNECTOR [GPS]** (p. 50)
Input position and UTC data (NMEA0183 ver. 3.01 format), such as from a GPS receiver, etc., for setting your positioning and time data automatically without manual input for DSC operation.

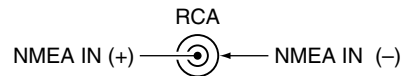

- 11 SPEAKER JACK [SP]** (p. 49)
Connects the supplied external speaker, SP-24E.
- 12 ANTENNA CONNECTOR 2** (p. 49)
Connects a 50 Ω HF band antenna via a 50 Ω matched coaxial cable with a PL-259 plug for DSC receiver.

■ Handset (HS-98)

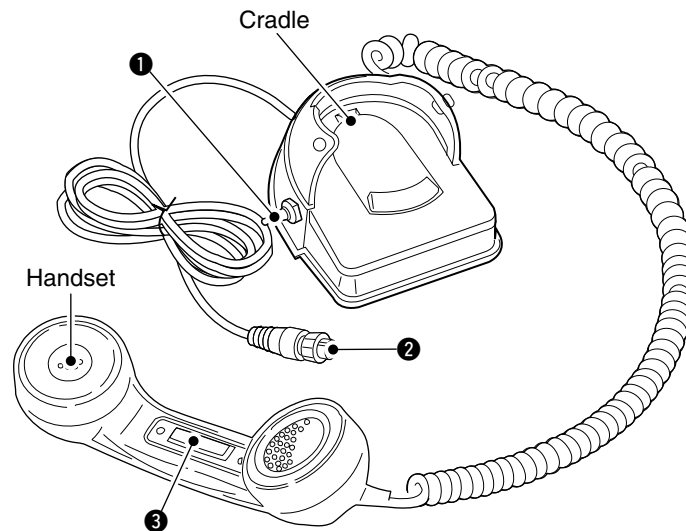

① SPEAKER SWITCH

Toggle the connected external speaker output ON and OFF when pick the handset up.

• **When the switch is set to “” position**

- Emits the receiving audio from the connected external speaker.

• **When the switch is set to “” position**

- Mutes the connected external speaker output.

• The receiving audio can be heard from the earpiece of the handset.

- Replace the handset into the cradle to emits the receiving audio from the connected external speaker.

② HANDSET CONNECTOR

Connects to [MIC] connector on the remote controller. (p. 49)

③ PTT SWITCH [PTT]

Push and hold to transmit; release to receive.

■ LCD screen

The IC-M801E has 2 indication types, one is channel name indication and the other is frequency indication. These indication types can be switched with a push of a button, depending on set mode's setting. See pages 8 and 44 for display type settings.

• Channel name indication

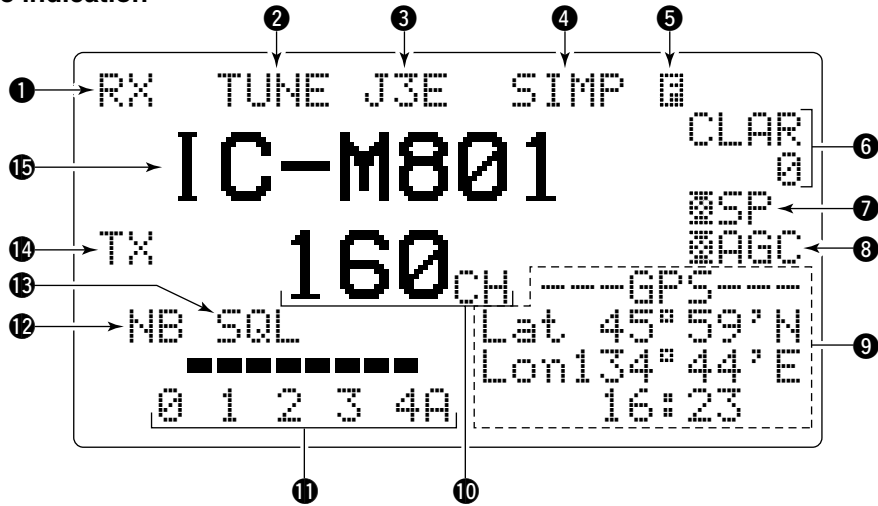

• Frequency indication

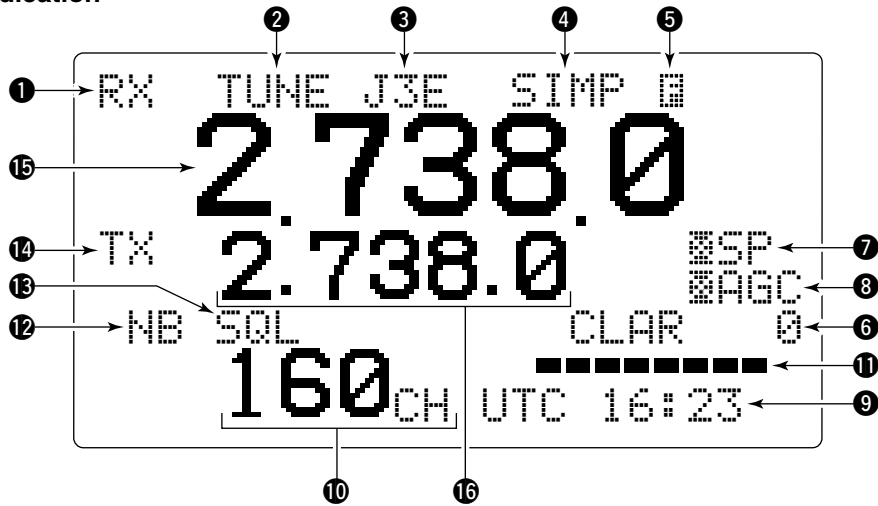

• DSC watch mode indication



1 RECEIVE INDICATOR

“RX” appears when signals are received or the squelch is open.

2 TUNE INDICATOR

“TUNE” blinks while tuning, if an optional external antenna tuner is connected. (p. 10)

- “TUNE” appears after tuning is completed with AT-141.
- “THRU” appears when the tuner through function is activated.
- “SWR” appears when the antenna SWR worsens during transmit, depending on the transmit output power. If it appears, check your antenna system.

3 OPERATING MODE INDICATOR

Shows the selected operating mode.

- “J3E,” “USB,” “H3E,” “AM,” “LSB,” “J2B,” “AFS,” “F1B,” “FSK,” “A1A” or “CW” appears depending on operating mode and setting.

4 SIMPLEX/DUPLEX INDICATOR

“SIMP” appears when a simplex channel is selected.

“DUP” appears when a duplex channel is selected.

5 FUNCTION INDICATOR

“F” appears when a secondary function can be accessed.

6 CLARITY INDICATOR (p. 12)

“CLAR” appears when the clarity function is activated and shows shifting frequency in “Hz.”

7 SPEAKER OFF INDICATOR (p. 10)

“SPOFF” appears when the speaker output is turned OFF.

8 AGC OFF INDICATOR (p. 11)

“SAGC” appears when the AGC OFF function is turned ON.

9 POSITION/UTC TIME INDICATOR (p. 15)

Shows position and/or UTC (or local) time. When an NMEA0183 ver. 3.01 data is applied to [GPS], the indication is up dated automatically.

- When no NMEA data is applied, the position and UTC time must be set in advance.
- “GPS” appears when an NMEA0183 ver. 3.01 data is applied to [GPS], “LAT” appears when the position is manually set.
- “UTC” appears when the offset time has not been programmed. (No “UTC” indication when offset time is programmed and shows local time.)

10 CHANNEL NUMBER INDICATION

Shows the selected channel number.

11 S/ANTENNA CURRENT INDICATOR

Shows relative driving antenna current levels during transmit and receiving signal strength during receive.

12 NOISE BLANKER INDICATOR (p. 11)

“NB” appears when the noise blanker function is activated.

13 SQUELCH INDICATOR (p. 11)

“SQL” appears when the squelch is ON.

14 TRANSMIT INDICATOR

- “TX” appears during transmit.
- “TX” blinks while monitoring a transmit frequency. (p. 10)

15 CHANNEL NAME/RECEIVE FREQUENCY READOUT

- Shows the programmed channel names.
- Shows receive frequency when no channel name is programmed, or during frequency indication.
- During DSC watch mode, displays “DSC WATCH.”

16 TRANSMIT FREQUENCY READOUT

Shows transmit frequency.

17 OPERATING GUIDE INDICATION

During DSC watch mode operation, shows several types of guidance, according to the selected condition.

18 SCANNING FREQUENCY READOUT

During DSC watch mode operation, shows the programmed scan frequency.

- Decimal points blink.

19 MMSI CODE INDICATION

During DSC watch mode operation, shows the programmed MMSI code.

■ Selecting a channel

The transceiver has 160 user channels and ITU channels. However, the number of user channels can be optionally restricted.

◇ Display selection

FREQUENCY indication

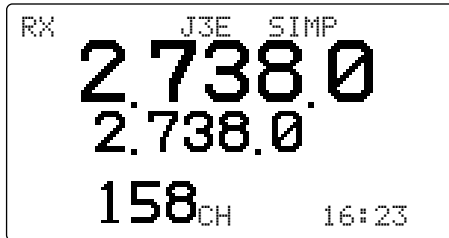

CHANNEL indication

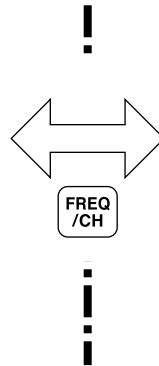
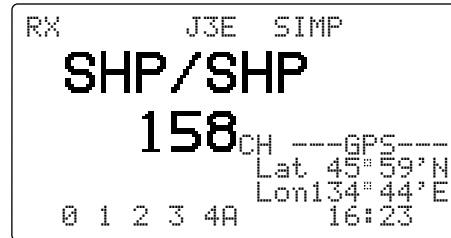

NOTE: Channel name (alphanumeric) may not appear during frequency indication depending on initial set mode setting. (p. 44)

◇ Using the channel selector

The transceiver has two large controls for group selection and channel selection. The [GRP] changes channels in 20 channel increments and selects ITU channel groups; and the [CH] selects each channel.

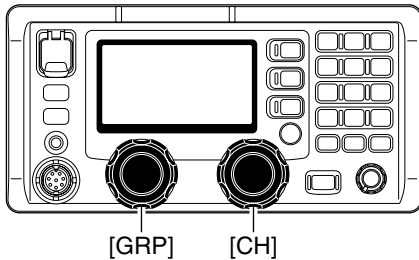

- ① Rotate [GRP] to select the desired channel group as shown at right and/or below.
- ② Rotate [CH] to select the desired channel.

[EXAMPLE]: Selection with the [GRP]

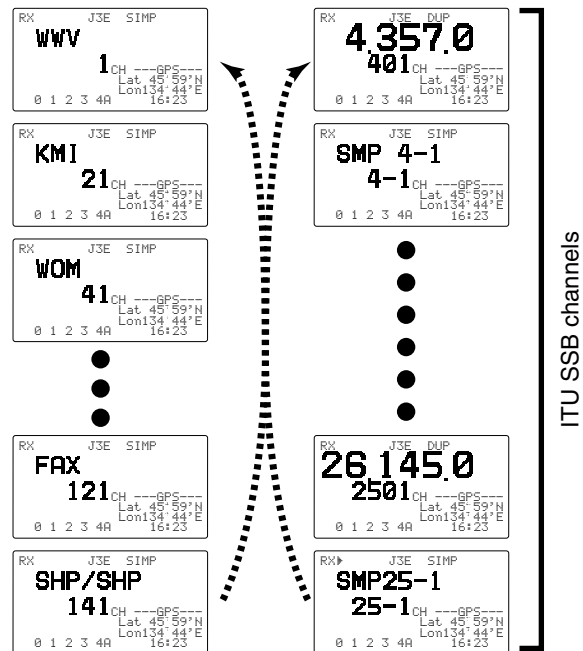

CHANNEL GROUPS

*[GRP] changes in 20 channels steps. *2SITOR use— no group separation.

Channel No.	Description	Channel No.	Description	Channel No.	Description
1 to 160	User Ch.*1	1201 to 1241	12 MHz ITU duplex Ch.	22-1 to 22-9	22 MHz ITU simplex Ch.
401 to 427	4 MHz ITU duplex Ch.	12-1 to 12-9	12 MHz ITU simplex Ch.	2501 to 2510	25 MHz ITU duplex Ch.
4-1 to 4-9	4 MHz ITU simplex Ch.	1601 to 1656	16 MHz ITU duplex Ch.	25-1 to 25-9	25 MHz ITU simplex Ch.
601 to 608	6 MHz ITU duplex Ch.	16-1 to 16-9	16 MHz ITU simplex Ch.	C1-1 to C1-21	C1 channels
6-1 to 6-9	6 MHz ITU simplex Ch.	1801 to 1815	18 MHz ITU duplex Ch.	C2-1 to C2-31	C2 channels
801 to 832	8 MHz ITU duplex Ch.	18-1 to 18-9	18 MHz ITU simplex Ch.	4001 to 25040	ITU FSK duplex Ch.*2
8-1 to 8-9	8 MHz ITU simplex Ch.	2201 to 2253	22 MHz ITU duplex Ch.		

◇ Using the keypad

Direct channel selection via the keypad is available for quick channel selection.

- ① Enter the desired channel number via the keypad.
 - Pushing [CE] clears input digits and retrieves the channel.
 - A user channel is selected when channel 1–160 is input (max. number may be optionally restricted).
 - An ITU SSB channel is selected when channel numbers higher than 401 are input.
 - When selecting an ITU simplex channel, push [0 DIM] three times to input “– (dash).” (e.g. When selecting the channel 4-1; — push [4 SP*], [0 DIM], [0 DIM], [0 DIM] then [1 NB].)
- ② Push [ENT] to select the channel.

[EXAMPLE]: Selecting channel 158

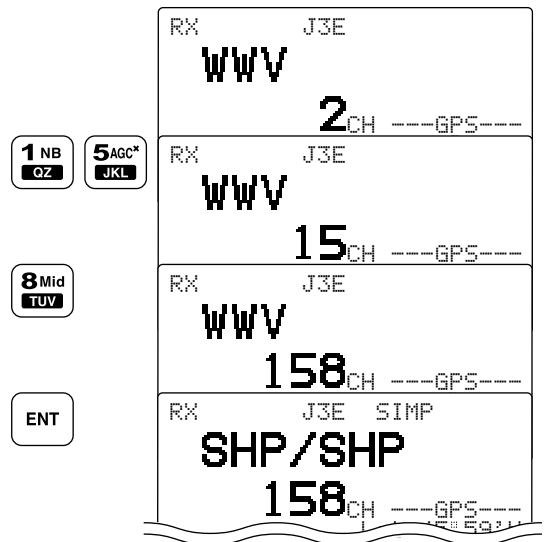

◇ Using scan function

The transceiver has automatic channel or frequency change capability (scan function). There are 3 types of scan functions available to suit your needs.

Channel scan/Channel resume scan

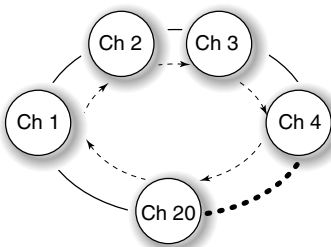

When resume OFF; scan does not pause even if a signal is received.

When resume ON; scan pauses for 10 sec., then resumes, or resumes after 2 sec. from when the signal disappears.

Programmed scan

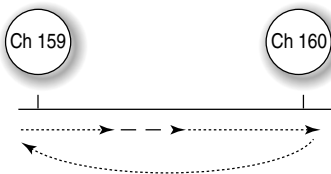

Scans the frequency range between the programmed frequencies on channels 159 and 160. Scans fast when squelch is closed and slowly when squelch is open.

Channel scan and channel resume scan increase channels within a 20 channel range, such as Ch 1 to Ch 20, Ch 141 to Ch 160, etc., in user channels; or all channels in the group of ITU channels.

Programmed scan scans frequencies within the frequency range between user channels 159 and 160.

Scan type selection is available in initial set mode. See p. 43 for the selection.

SCAN OPERATION

- ① Rotate [GRP] and [CH], or use the keypad to select your desired channel group.
 - This operation is not necessary for programmed scan.
- ② Push [F] then [2 SQL] to turn OFF the squelch function, if programmed scan is selected.
- ③ Push [F] then [3 SCAN] to start the scan.
- ④ To stop the scan, repeat step ③ again.
 - [CH] rotation or pushing some other switches also stops the scan.

Basic voice transmit and receive

- ① Check the following in advance.
 - ➔ Handset or microphone is connected.
 - ➔ No "SQL" indication.
 - If "SQL" appears, push [F] then [2 SQL] to turn the squelch OFF.
 - ➔ No "SP" indication.
 - If "SP" appears, push [F] then [4 SP*] to activate the speaker.
 - ➔ The clarity function is not activated.
 - If the clarity function is activated, push [F] then [RX CLAR] to turn the function OFF.
- ② Rotate [GRP] and [CH] to select the desired channel to be received.
 - When receiving a signal, the S-meter shows the signal strength.
- ③ Adjust [VOL] to the desired audio level when receiving a signal.
- ④ Push [MODE SET] to select the desired operating mode.
- ⑤ Push [TUNE THRU] to tune the antenna tuner, if connected.
 - Skip this operation when the "AUTO TUNE" is set to ON in initial set mode (p. 43).
- ⑥ To transmit on the channel, push and hold the PTT switch on the handset or microphone.
 - "TUNE" blinks for 1 to 2 sec. for the first transmission on a channel when the automatic tuning function is activated.
- ⑦ Speak into the handset or microphone at your normal voice level.
 - The RF meter shows the output power according to your voice level.
 - If "SUR" appears, check your antenna system.
- ⑧ Release the PTT switch to return to receive.

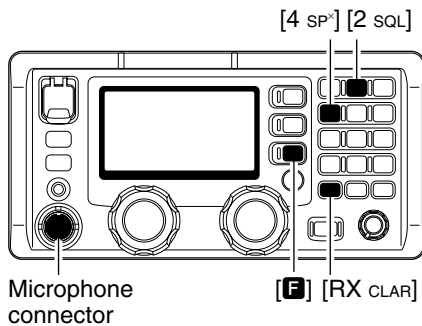

Function for transmit

◆ Transmit frequency check

When "DUF" appears in the display such as for a ship-to-ship channel, the transmit frequency differs from the receive frequency.

In such cases, the transmit frequency should be monitored before transmitting to prevent interference to other stations.

- ➔ Push [F] then push and hold [TX TXF] to monitor the transmit frequency.

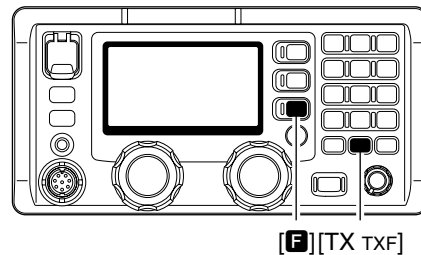

- "TX" blinks and the display shows the transmit frequency.

■ Functions for receive

◇ Squelch function

The squelch function detects signals with voice components and squelches (mutes) unwanted signals such as unmodulated beat signals. This provides quiet stand-by.

When you need to receive weak signals, the squelch should be turned OFF.

➔ Push [F] then [2 SQL] to switch the function ON and OFF.

• See page 42 for the squelch level adjustment.

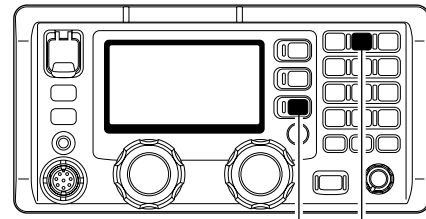

[F] [2 SQL]

• “SQL” appears when the squelch function is turned ON.

◇ Noise blanker

The noise blanker function reduces pulse type noise such as that coming from engine ignitions, etc.

The noise blanker may distort reception of strong signals. In such cases, the noise blanker should be turned OFF.

➔ Push [F] then [1 NB] to switch the function ON and OFF.

• See page 42 for the noise blanker level adjustment.

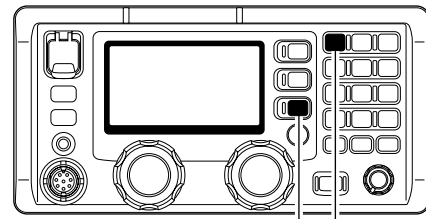

[F] [1 NB]

• “NB” appears when the NB function is turned ON.

◇ AGC OFF function

The receive gain is automatically adjusted according to received signal strength with the AGC (Automatic Gain Control) function to prevent distortion from strong signals and to obtain a constant output level.

When receiving weak signals with adjacent strong signals or noise, the AGC function may reduce the sensitivity. In this situation, the AGC function should be deactivated.

➔ Push [F] then [5 AGC*] to switch the function ON and OFF.

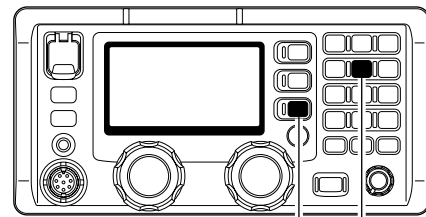

[F] [5 AGC*]

• “AGC” appears when the AGC function is turned OFF.

◇ RF gain setting

The receiver gain can be reduced with the RF gain setting. This may help to remove undesired weak signals while monitoring strong signals.

Usually, the AGC function reduces the RF gain according to the receive signal strength and these weak signals are removed. However, during no signal reception, these weak signals may not be heard.

In such cases, the RF gain may be useful for setting a minimum level at which to hear signals.

① Push [F] then [6 RF-G] to select the RF gain set mode, as shown below.



② Rotate [CH] to set the desired minimum cutting level.

• “0 (low sensitivity)” to “9 (max. sensitivity)” are available.

• S-meter shows the minimum permitted level.

③ Push any key to exit the RF gain set mode.

■ Functions for receive (continued)

◆ Clarity control

Voice signals received from other stations may be difficult to receive. This may sometimes happen if a station is transmitting slightly off frequency. In such cases, you can compensate by using the clarity control.

- ① Push **[F]** then **[RX CLAR]** to switch the function ON and OFF.
 - “CLAR” and shifting value with direction appear.
- ② Rotate **[CH]** to improve the audio readability.
 - Adjustable between ± 150 Hz in 10 Hz steps.

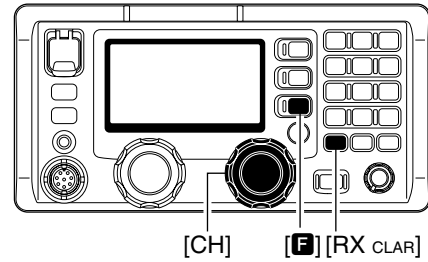

◆ Tuner through function

In the combination with IC-M801E and optional AT-141, the tuner through function can be used.

By bypassing the tuner unit, the receiver gain in particular frequency band may be improved depending on your antenna element length.

- ➔ While “TUNE” is displayed, push **[F]** then **[TUNE THRU]** to tuner through function ON.
 - “THRU” appears instead of “TUNE” indicator.
 - Push **[TUNE THRU]** to turn the function OFF.

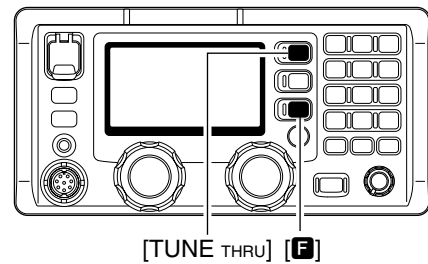

■ FSK operation

The transceiver has FSK and J2B modes for FSK operation— use F1B when using the built-in oscillator; use J2B when using an AFSK terminal unit.

- ① Connect an FSK terminal unit to the **[AF/MOD]** socket as shown at right.
- ② Select the desired channel to operate FSK mode.
 - FSK ITU channel group, Ch 4001 to Ch 25040, are only available when SITOR CH setting is set to ON. (p. 43)
- ③ Push **[MODE SET]** several times to select F1B (FSK) or J2B (AFSK).
- ④ Operate the FSK terminal unit.

NOTE:

- ➔ FSK tone, shift frequency and FSK polarity can be adjusted in initial set mode (p. 45)
- ➔ Some transceivers may operate 1.7 kHz higher than the IC-M801E's J2B mode even when the same displayed frequencies are in use.

FSK terminal unit connection

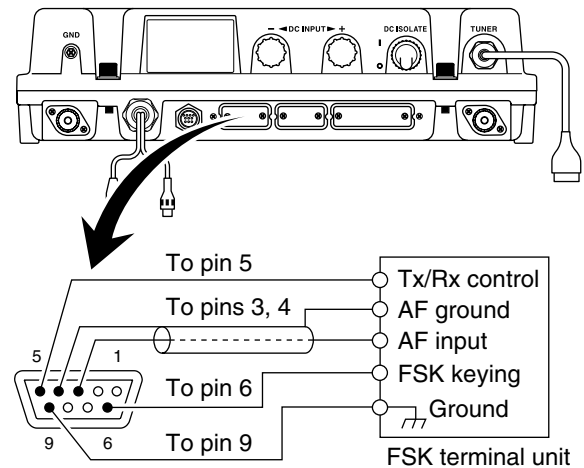

Up to 8-character channel names can be assigned for each user and ITU channel. This may be helpful for indicating the frequency usage, ship name, etc.

NOTE: The display type must be set to "CHANNEL NAME" to display/program the channel names in initial set mode. (p. 44).

◇ Programming

- ① Select the desired channel to be programmed.
- ② Push [FREQ/CH] to select channel indication mode, if desired.
- ③ Push [**☀**] then [FREQ/CH].
 - The 1st character for the channel names blinks.

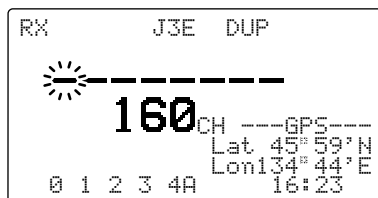

- ④ Rotate [CH] selector to select the character for channel names.
 - See the table below for available characters.

- ⑤ Push the keypad several times to enter that character.

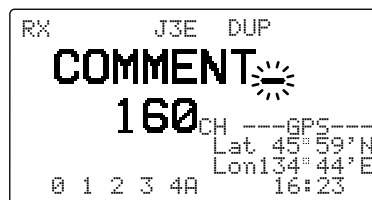

- ⑥ Repeat steps ④ and ⑤ to enter the channel name.
- ⑦ Push [ENT] for 1 sec. to program the channel name.

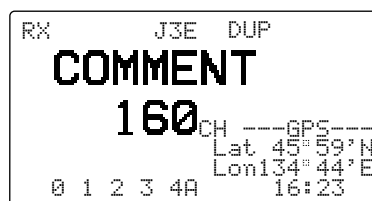

• Available characters

KEY	CHARACTERS	KEY	CHARACTERS
1 NB QZ	1 Q Z q z (space)	6 RF-G MNO	6 M N O m n o
2 SQL ABC	2 A B C a b c	7 Lo PRS	7 P R S p r s
3 SCAN DEF	3 D E F d e f	8 Mid TUV	8 T U V t u v
4 SP* GHI	4 G H I g h i	9 Hi WXY	9 W X Y w x y
5 AGC* JKL	5 J K L j k l	0 DIM - /	0 - / . ' () * + < = > @

■ MMSI code programming

The 9-digit MMSI (Maritime Mobile Service Identity: DSC self ID) code can be programmed.

 This operation is not available when the MMSI code has been programmed by your dealer. The code re-programming cannot be performed. This code is displayed during DSC watch mode.

◇ Programming

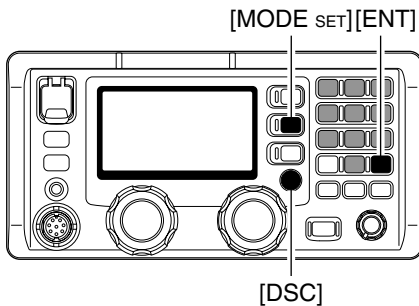

- ① The following screen will be displayed briefly at power ON when no MMSI code is programmed.



- ② Push [DSC] to select MMSI code programming condition.

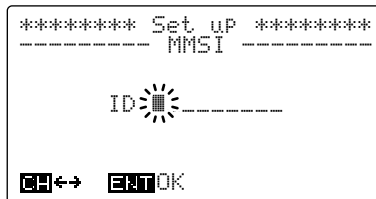

- ③ Enter the specified 9-digit MMSI code via the keypad.

- Make sure the correct code is entered.
- Rotate [CH] to move the cursor.



- ④ Push [ENT] to program the code.

- After pushing [ENT], DSC menu is displayed as below.

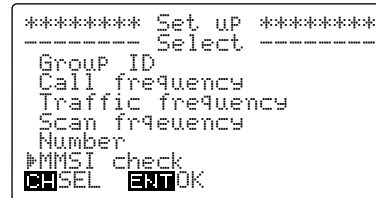

- ⑤ Push [MODE SET] to exit the DSC menu.

Position and time programming

When no position and the UTC (Universal Time Coordinated) time data in NMEA0183 ver. 3.01 format, such as from a GPS receiver, etc., is applied to [GPS] connector, your position and the UTC time should be input for DSC operation.

IMPORTANT!

Manually programmed position and time data will be held for 23.5 hours only, and “?” symbol is displayed for all digits instead of the programmed data after 4 hours from programming. They are never renewed during the voyage when the position is set manually.

- While pushing and holding [MODE SET] push [POWER] to enter initial set mode.
 - Turn the power OFF in advance.

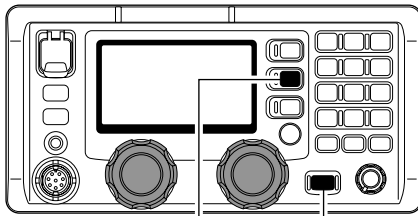

[MODE SET] [POWER]

- Rotate [GRP] to select the “GPS DISPLAY” then rotate [CH] to select the desired position indication type from simple and detail.



- Rotate [GRP] to select the “OFFSET TIME” then rotate [CH] to set the time difference between local and the UTC times within -12 to +12 hours in 10 minute steps.



- Turn the power OFF once, then ON again to exit quick set mode.

When a position and the UTC time data (NMEA0183 ver. 3.01 format) is applied to [GPS], the following steps are not necessary.

- Push [DSC] to select DSC watch mode.
- Push [MODE SET] to enter the DSC menu.
 - DSC menu is displayed as below.
- Rotate [CH] to select “Position,” then push [ENT].

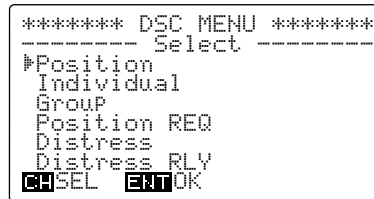

- Enter your position and the UTC time via the keypad, then push [ENT].
 - Push [3 SCAN] for the ‘East,’ [9] for the ‘West,’ [6 RF-G] for the ‘North’ and [7] for the ‘South’ setting.
 - Rotate [CH] to move the cursor.

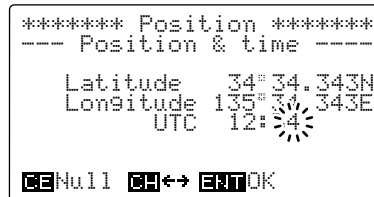

- Push [ENT] to program the position and time.
 - Return to the “DSC MENU” indication as in step ⑦.
- Push [MODE SET] to exit the DSC menu.
 - Rotate [CH] to select “Exit” then push [ENT] also exits set mode.
 - “MNL” appears instead of “GPS.”

Simple position indication

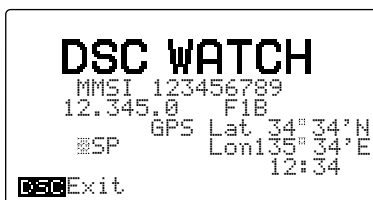

Detail position indication



■ Distress call

A distress call should be transmitted if in the opinion of the Master, the ship or person is in distress and requires immediate assistance.

A distress call should include the ship's position and time. They are included automatically when their data in NMEA0183 ver. 3.01 format is applied to [GPS] connector. When no data is applied, input them, if possible.

A distress call some times called as a "MAYDAY call."

NEVER USE THE DISTRESS CALL WHEN YOUR SHIP OR A PERSON IS NOT IN AN EMERGENCY. DISTRESS CALLS CAN BE USED ONLY WHEN IMMEDIATE HELP IS NEEDED.

◇ Distress call operation outline

• Simple distress call

Push and hold [DISTRESS] for 5 sec.

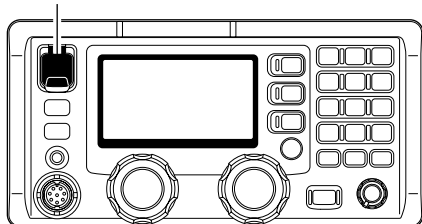

• Regular distress call

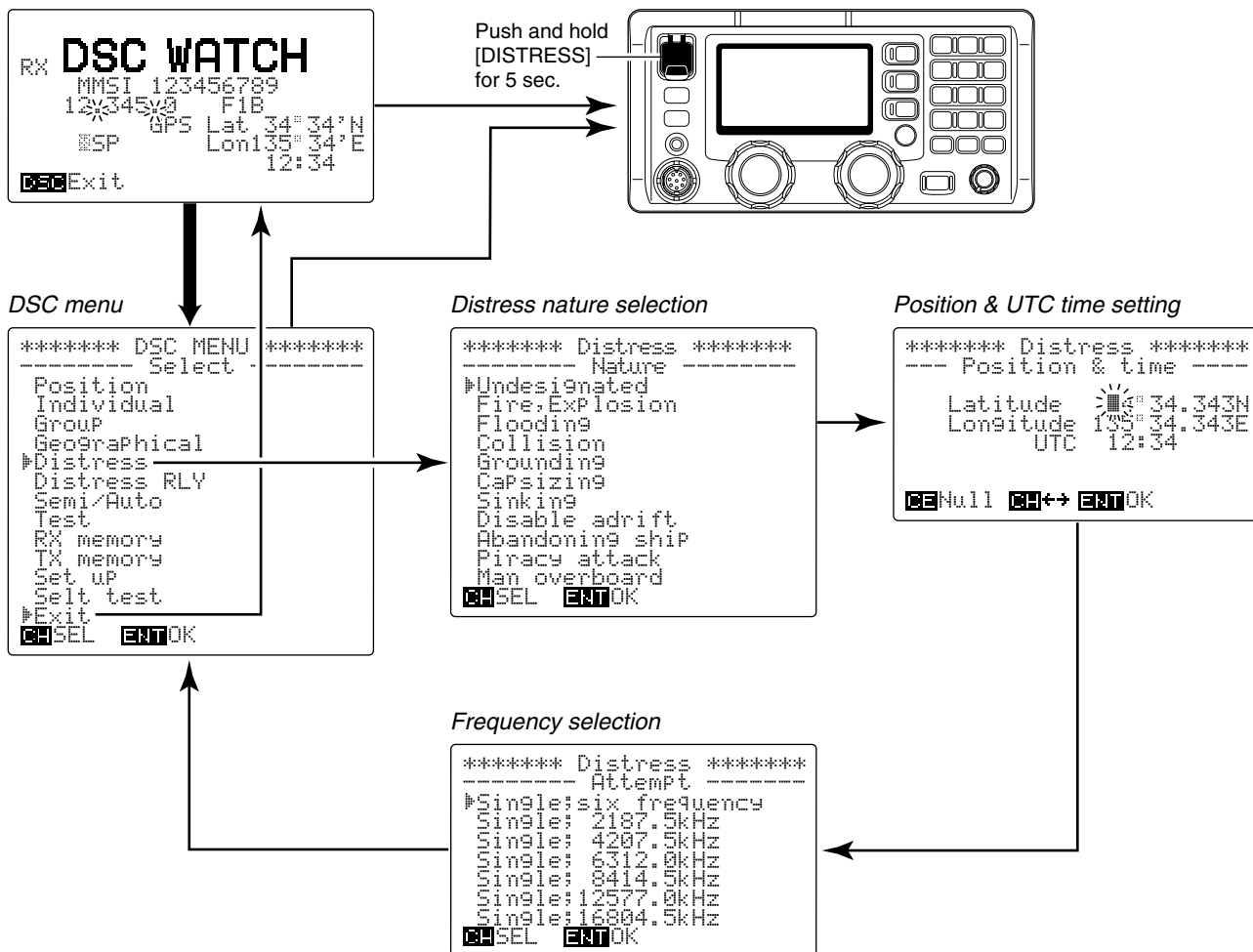

◇ Simple distress call

NOTE:

- Distress alert (simple operation) contains (default);
Distress nature : Undesignated distress.
Position data : According to the displayed information.
- Distress call repeats every 3.5–4.5 min., until receiving an acknowledgement.

- ① Confirm a distress call is not being received.
- ② Lift up the distress switch cover, push [DISTRESS] for 5 sec. to transmit the distress call.
 - An emergency frequency (default: 8414.5 kHz) is automatically selected and the distress call is transmitted.
 - If you have time, select the nature of the distress and contents (p. 18).
 - When no position and time data is applied to [GPS], your location and UTC time should be input.

[DISTRESS]

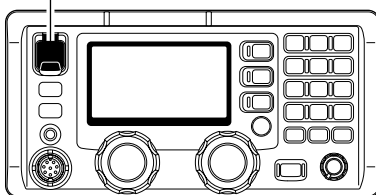

```

DISTRESS
RX < Push 5sec. >
8.414.5 F1B
GPS Lat 34° 34' N
Lon135° 34' E
12:34
  
```



After 5 sec.,
starts distress call.

```

TX DISTRESS
CALLING
8.414.5 F1B
GPS Lat 34° 34' N
Lon135° 34' E
12:34
[REPEATS]
CANCELExit
  
```

- ③ After transmitting the call, the transceiver is set to the phone emergency frequency automatically (e.g. 8291.0 kHz).
 - The DSC receiver circuit is still working to receive an acknowledgement call on the previous frequency (e.g. 8414.5 kHz).

```

DISTRESS
RX < Wait for ACK >
8.291.0 J3E
GPS Lat 34° 34' N
Lon135° 34' E
12:34
CANCELExit
  
```

- ④ When receiving an acknowledgement, push [CANCEL] to stop the alarm then reply to the connected station via the transceiver's handset or microphone.
 - The acknowledgement is memorized into the RX memory channel. (p. 30)

```

DISTRESS
RX < ACK received >
8.291.0 J3E
GPS Lat 34° 34' N
Lon135° 34' E
12:34
FREQExit
  
```

- ⑤ Activate an EPIRB (Emergency Position Indicating Radio Beacon) and prepare a SART (Search And Rescue Transponder) and VHF marine handheld transceiver before launching a survival craft.

◆ Regular distress call

Transmit a distress call after selecting "Distress" in the DSC menu.

NEVER USE THE DISTRESS CALL WHEN YOUR SHIP OR A PERSON IS NOT IN AN EMERGENCY. DISTRESS CALLS CAN BE USED ONLY WHEN IMMEDIATE HELP IS NEEDED.

- ① Push [DSC] to select DSC watch mode.
- ② Push [MODE SET] to select the DSC menu.

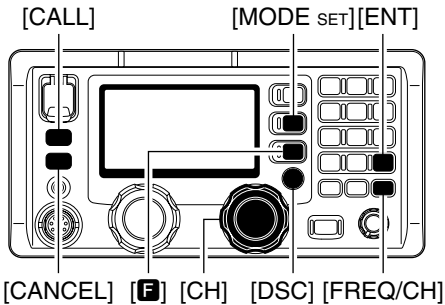

- ③ Rotate [CH] to select "Distress," then push [ENT].



- ④ Rotate [CH] to select the desired nature then push [ENT].

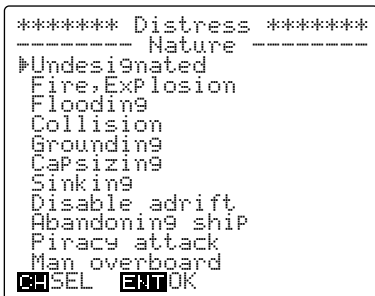

- ⑤ Verify the position and UTC time data, then push [ENT].
 - When no position and time data is applied to [GPS], your position and UTC time should be input in this step.

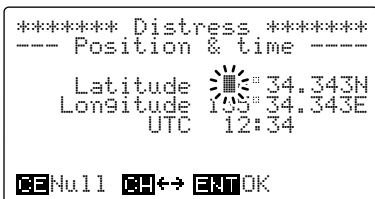

- ⑥ Rotate [CH] to select the desired distress frequency, then push [ENT].
 - After pushing [ENT], return to the DSC menu as shown in step ③.



- ⑦ Lift up the distress switch cover, push [DISTRESS] for 5 sec. to transmit the distress call.
 - The distress call is transmitted on the emergency frequency selected in step ⑥.
- ⑧ After transmitting the call, the transceiver is set to the phone emergency frequency automatically.
 - The DSC receiver circuit is still working to receive an acknowledgement call on the previous frequency.
 - The distress call transmission and acknowledgement reception are performed on the all distress frequencies (2187.5, 4207.5, 6312.0, 8414.5, 12577.0 and 16804.5 kHz) in sequence when "Single:six frequency" is selected in step ⑥.

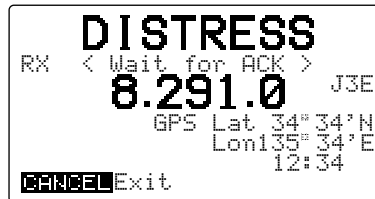

- ⑨ When receiving an acknowledgement, push any key to stop the alarm then reply to the connected station via the transceiver's handset or microphone.
 - The acknowledgement is memorized into the RX memory channel. (p. 30)

◆ When no acknowledgement is received

If no acknowledgement is received, the emergency alarm will sound continuously. In this case, the IC-M801E automatically transmits the distress call again every 3.5 to 4.5 minutes.

- Push any key if you want to stop the alarm.

CAUTION!

DO NOT push [CANCEL] while waiting for an acknowledgement, otherwise the distress call repeat is cancelled.

Push [CANCEL] only when you want to cancel repeated transmission.

◆ After receiving an acknowledgement call

The following should commence your voice transmission after receiving a distress acknowledgement from a coast station (or another ship).

- “MAYDAY”
- “This is (your ship name).”
- The 9-digit identity **AND** the call sign (or other identification of the ship).
- The ship’s position if the DSC distress does not included it.
- The nature of the distress and assistance required.
- Any other information which might facilitate the rescue.

Individual call

When you use DSC for general selective calling, perform as follows.

Operation outline

DSC menu

```
***** DSC MENU *****
----- Select -----
Position
▶Individual
Group
Geographical
Distress
Distress RLY
Semi/Auto
Test
RX memory
TX memory
Set up
Self test
▶Exit
[CHSEL] [ENT]OK
```

Address ID selection

```
***** Individual *****
----- Address ID -----
▶Manual set
IC-M801-1 123456789
IC-M801-2 123456788
IC-M801-3 123456787
IC-M801-4 123456786
IC-M801-5 123456785
[CHSEL] [ENT]OK
```

Manual ID input

```
***** Individual *****
----- Address ID -----
☀-----
[CH↔] [ENT]OK
```

Traffic frequency selection 1

```
***** Individual *****
----- Traffic frequency ---
Manual set-----
▶T: 2134.0kHz IC-M801-1
R: 2134.0kHz
T:12345.0kHz IC-M801-2
R:12345.0kHz
[CHSEL] [ENT]OK
```

Traffic frequency selection 2

```
***** Individual *****
----- Traffic frequency ---
Manual set-----
TX:☀2134.0kHz
RX:2134.0kHz
[CH↔] [ENT]OK
```

Call frequency selection 1

```
***** Individual *****
----- Call frequency -----
Manual set-----
▶T: 2177.0kHz SHIP
R: 2177.0kHz
T: 2189.5kHz INTER2-1
R: 2177.0kHz
[CHSEL] [ENT]OK
```

Call frequency selection 2

```
***** Individual *****
----- Call frequency -----
Manual set-----
TX:☀177.0kHz
RX:2177.0kHz
[CH↔] [ENT]OK
```

Confirmation screen

```
***** Individual *****
----- Call -----
To: IC-M801-1
Category: Routine
Traffic: J3E
TX 2134.0kHz
RX 2134.0kHz
Call Freq: TX 2177.0kHz
RX 2177.0kHz
[CALL] Call [ENT] Write-Menu
```

Push [CALL] for 1 sec. to start calling.
Push [ENT] for 1 sec. to store the condition into the TX memory channel.

◆ Individual call operation

- ① Push [MODE SET] to select the DSC menu.
- ② Rotate [CH] to select "Individual," then push [ENT].
- ③ Select (or enter) the 9-digit ID code, then push [ENT].
 - Use [CH] to select the ID code when the desired ship's ID is pre-programmed.

```
***** Individual *****
----- Address ID -----
▶Manual set
IC-M801-1 123456789
IC-M801-2 123456788
IC-M801-3 123456787
IC-M801-4 123456786
IC-M801-5 123456785
[CH]SEL [ENT]OK
```

- Select "Manual set" with [CH] then push [ENT], after that, enter the desired 9-digit ID via the keypad.

```
***** Individual *****
----- Address ID -----

TX: [sun]-----
RX: [sun]-----

[CH]↔ [ENT]OK
```

- ④ Rotate [CH] to select the desired pre-programmed traffic frequency, or "Manual set" then push [ENT].
 - ✓ When the pre-programmed traffic frequency is selected, go to step ⑤.

```
***** Individual *****
-- Traffic frequency --
Manual set
▶T: 2134.0kHz IC-M801-1
R: 2134.0kHz
T: 12345.0kHz IC-M801-2
R: 12345.0kHz
[CH]SEL [ENT]OK
```

- When "Manual set" is selected, enter the desired calling frequency via the keypad.

```
***** Individual *****
-- Traffic frequency --

TX: [sun]134.0kHz
RX: [sun]2134.0kHz

[CH]↔ [ENT]OK
```

- ⑤ Rotate [CH] to select the desired pre-programmed calling frequency, or "Manual set" then push [ENT].
 - ✓ When the pre-programmed call frequency is selected, go to step ⑥.

```
***** Individual *****
----- Call frequency -----
Manual set
▶T: 2177.0kHz SHIP
R: 2177.0kHz
T: 2189.5kHz INTER2-1
R: 2177.0kHz
[CH]SEL [ENT]OK
```

- When "Manual set" is selected, enter the desired calling frequency via the keypad.

```
***** Individual *****
----- Call frequency -----

TX: [sun]177.0kHz
RX: [sun]2177.0kHz

[CH]↔ [ENT]OK
```

- ⑥ The calling stand-by screen is displayed as follows, verify the calling condition then push and hold [CALL] for 1 sec. to transmit the call.
 - Push and hold [ENT] for 1 sec. to store the calling condition into the TX memory described in pages 22 and 37, if desired.

```
***** Individual *****
----- Call -----
To: IC-M801-1
Category: Routine
Traffic: J3E
TX 2134.0kHz
RX 2134.0kHz
Call Freq: TX 2177.0kHz
RX 2177.0kHz
[CALL]Call [ENT]Write-Menu
```

- ⑦ After sending the call, the transceiver waits for an acknowledgement.

```
Individual
< Wait for ACK >

2.177.0 F1B
GPS Lat 34° 34' N
Lon 135° 34' E
12:34

[FREQ]Exit
```

☞ Continue to the next page

◇ Individual call operation— continued

⑧ When receiving an acknowledgement, the display shows the received ID code, or the called station name.

- Push [FREQ/CH];
- to select the traffic frequency if the called station is able to comply to the call.
- to return to DSC watch mode when unable.

```
*****
* Individual ACK *
* IC-M801 *
* Able to comply *
*****
[FREQ]Exit
```

```
*****
* Individual ACK *
* IC-M801 *
* Unable to comply *
* Operator unavailable *
*****
[FREQ]Exit
```

When the called station is unable to comply to the call, the reason may be displayed.

⑨ Announce the following message to the connected station.

- The 9-digit identity (or call sign or other identification) of the station which you want to call.
- "This is (your ship name)."
- The 9-digit identity **OR** call sign (or other identification) of the ship).

When no acknowledgement is received:

- 1 Wait for 5 min., then call again on the same or a different frequency.
- 2 If no acknowledgement is received after a 2nd call, wait for at least 15 min. before repeating the call.

✓ **INFORMATION**

The IC-M801E will not transmit the DSC call (except emergency call) even [CALL] when the set calling frequency is in busy. The transceiver waits the DSC call transmission until the calling frequency becomes clear in this case.

✓ **CONVENIENT!**

The IC-M801E has DSC TX memory. You can store often used DSC calling conditions for quick and simple re-call. Up to 10 conditions can be stored into the memory with the following instructions.

- 1 When call stand-by screen is displayed as in step ⑥ in page 21, push and hold [ENT] for 1 sec.
- 2 Rotate [CH] to select the desired TX memory channel number.

```
***** Individual *****
--- TX memory write ---
#0:
1:
2:
3:
4:
5:
[CH]SEL [ENT]Write
```

- 3 Push and hold [ENT] for 1 sec. again to store the condition into the selected memory channel.

```
***** Individual *****
--- TX memory write ---
#0: Individual 987654321
1:
2:
3:
4:
5:
[CH]SEL [ENT]OK
```

- 4 Push [ENT] to return to the calling stand-by condition.

```
***** TX memory *****
----- Individual -----
To: IC-M801_1
Category: Routine
Traffic: J3E
TX 2134.0kHz
RX 2134.0kHz
Call Freq: TX 2177.0kHz
RX 2177.0kHz
[CALL]Call [CE]DEL
```

- 5 Push and hold [CALL] for 1 sec. when transmitting the DSC call in set condition, or push [MODE SET] when returning to DSC watch mode.

■ Group call

When you use DSC for calling the desired ship's group, use "Group" menu.

- ① Push [MODE SET] to select the DSC menu.
- ② Rotate [CH] to select "Group" then push [ENT].
- ③ Select the desired 9-digit group code, then push [ENT].
 - Use [CH] to select the group code when the desired group is pre-programmed.

```
***** Group *****
----- Group ID -----
▶Manual set
Group-1 023456789
Group-2 023456788
Group-3 023456787
Group-4 023456786
Group-5 023456785
[CH]SEL [ENT]OK
```

- When "Manual set" is selected, enter the desired code (last 8 digits only) via the keypad.
- The first digit "0 (zero)" is fixed for group code.

```
***** Group *****
----- Group ID -----
          [CH]
          [ENT]OK
```

- ④ Rotate [CH] to select the desired pre-programmed traffic frequency, or "Manual set" then push [ENT].
 - ✓ When the pre-programmed call frequency is selected, go to step ⑤.

```
***** Group *****
-- Traffic frequency ---
Manual set
▶T: 2134.0kHz IC-M801-1
R: 2134.0kHz
T: 12345.0kHz IC-M801-2
R: 12345.0kHz
[CH]SEL [ENT]OK
```

- When "Manual set" is selected, enter the desired traffic frequency via the keypad.

```
***** Group *****
-- Traffic frequency ---
          TX: [CH]
          RX: [ENT]OK
```

- ⑤ Rotate [CH] to select the desired pre-programmed calling frequency, or "Manual set" then push [ENT].
 - ✓ When the pre-programmed call frequency is selected, go to step ⑥.

```
***** Group *****
---- Call frequency ----
Manual set
▶T: 2177.0kHz SHIP
R: 2177.0kHz
T: 2189.0kHz INTER2-1
R: 2177.0kHz
[CH]SEL [ENT]OK
```

- When "Manual set" is selected, enter the desired calling frequency via the keypad.

```
***** Group *****
---- Call frequency ----
          TX: [CH]
          RX: [ENT]OK
```

- ⑥ The calling stand-by screen is displayed as follows, verify the calling condition then push and hold [CALL] for 1 sec. to transmit the group call.
 - Push and hold [ENT] for 1 sec. to store the calling condition into TX memory described in pages 22 and 37, if desired.

```
***** Group *****
Call -----
To: Group-1
Category: Routine
Traffic: J3E
          TX 2134.0kHz
          RX 2134.0kHz
Call Freq: TX 2177.0kHz
          RX 2177.0kHz
[CALL]Call [ENT]Write-Menu
```

- ⑦ After sending the call, the traffic frequency is selected automatically.

```
< Traffic >
RX 2.134.0 J3E
GPS Lat 34° 34' N
Lon 135° 34' E
12:34
[FREQ]Exit
```

- ⑧ Announce the following message to stations.
 - "The group name."
 - "This is (your ship name)."
 - The 9-digit identity **OR** call sign (or other identification of the ship).

■ Geographical call

Use the geographical call when urgency or safety message announcement is necessary to the ships in the particular area.

- ① Push [MODE SET] to select the DSC menu.
- ② Rotate [CH] to select the "Geographical," then push [ENT].
- ③ Rotate [CH] to select the category from "Safety" and "Urgency," then push [ENT].

```
***** Geographical *****
----- Category -----
▶Safety
  Urgency
[CHSEL] [ENT]OK
```

- ④ Rotate [CH] to select the desired area designated method, then push [ENT].

```
***** Geographical *****
----- Area -----
▶Centre-Point
  Area
[CHSEL] [ENT]OK
```

- ⑤ Enter the position information (latitude and longitude) with range or area, then push [ENT].
- When "Centre-Point" is selected

```
***** Geographical *****
----- Centre-Point -----
Latitude  ☀° ___'N
Longitude  ▲° ___'W
Range:    ___nm
[CH↔] [ENT]OK
```

-When "Area" is selected

```
***** Geographical *****
----- Area -----
Latitude  ☀°N-H: ___
Longitude  ▲°W-U: ___
[CH↔] [ENT]OK
```

- ⑥ Rotate [CH] to select the desired pre-programmed traffic frequency, or "Manual set" then push [ENT].
- ✓When the pre-programmed call frequency is selected, go to step ⑦.

```
***** Geographical *****
--- Traffic frequency ---
Manual set
▶T: 2134.0kHz IC-M801-1
R: 2134.0kHz
T:12345.0kHz IC-M801-2
R:12345.0kHz
[CHSEL] [ENT]OK
```

- When "Manual set" is selected, enter the desired traffic frequency via the keypad.

```
***** Geographical *****
--- Traffic frequency ---
TX:☀182.0kHz
RX:▲2182.0kHz
[CH↔] [ENT]OK
```

- ⑦ Rotate [CH] to select the desired pre-programmed calling frequency, then push [ENT].

```
***** Geographical *****
--- Call frequency ---
▶ 2187.5kHz
  4287.5kHz
  6312.0kHz
  8414.5kHz
  12577.0kHz
  16804.5kHz
[CHSEL] [ENT]OK
```

- ⑧ The calling stand-by screen is displayed as follows, verify the calling condition then push and hold [CALL] for 1 sec. to transmit the position request call.
- Push and hold [ENT] for 1 sec. to store the calling condition into the TX memory as described in pages 22 and 37, if desired.

```
***** Geographical *****
----- Call -----
To area: 14°N-H: 3
        125°W-U: 3
Category: Safety
Traffic: J3E
TX 2182.0kHz
RX 2182.0kHz
Call Freq: TX 2187.5kHz
          RX 2187.5kHz
[CALL] Call [ENT] Write-Menu
```

- ⑨ After sending the call, the transceiver selects the set traffic frequency automatically.

```

RX      < Traffic >
        2.182.0   J3E
        GPS Lat 34° 34' N
          Lon 135° 34' E
          12:34
[FREQ]Exit
  
```

- ⑩ Announce the following message.

- **‘Urgency’ is selected in step ③**
- “PAN PAN”
- **‘Safety’ is selected in step ③**
- “SECURITE” (repeat 3 times)
- This is (your ship name)
- The 9-digit identity and the call sign (or other identification of the ship).
- The text of the urgency or safety message.

- ⑪ After the announcement, push [FREQ/CH] to return to DSC watch mode.

✓ For your information— Area input

When using the ‘Geographical’ for distress relay call with “Area” selection, your original position is always the upper left hand corner in the world map as in the following illustration.

• Area setting example 1

```

Latitude 20°N-H:10
Longitude 100°W-U:20
  
```

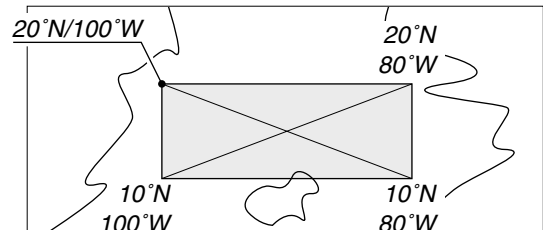

• Area setting example 2

```

Latitude 20°S-H:10
Longitude 100°E-U:20
  
```

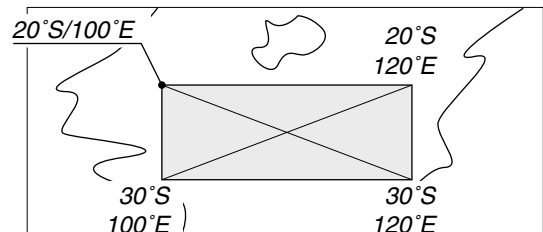

■ Semi/Auto (telephone) call

The frequency for telephone call use are specified by a coast station, therefore, two calls/acknowledgements are usually necessary before making a telephone call.

- ① Push [MODE SET] to select the DSC menu.
- ② Rotate [CH] to select "Semi/Auto" call, then push [ENT].
- ③ Rotate [CH] to select "Calling" then push [ENT].

```
***** Semi/Auto *****
----- Action -----
▶Calling
Answer Setting

[CH]SEL [ENT]OK
```

- ④ Select the desired pre-programmed telephone number or "Manual set," then push [ENT].
 - Use [CH] to select the telephone number when pre-programmed.

```
***** Semi/Auto *****
----- Number -----
▶Manual set

ICOM1
1234567890123456
ICOM2
1234567890123457
[CH]SEL [ENT]OK
```

•When "Manual set" is selected, enter the desired telephone number via the keypad.

```
***** Semi/Auto *****
----- Number -----

[CH]↔ [ENT]OK
```

- ⑤ Rotate [CH] to select the desired coast station code, then push [ENT].

```
***** Semi/Auto *****
----- Address ID -----
▶Manual set
Port ICOM 001234567
Port ABC 001234566
Port M801 001234565

[CH]SEL [ENT]OK
```

- When "Manual set" is selected, enter the desired code (last 7 digits only) via the keypad.
- The first 2 digits "00 (double zero)" are fixed for the coast station code.

```
***** Semi/Auto *****
----- Address ID -----

[CH]↔ [ENT]OK
```

- ⑥ Rotate [CH] to select 1st telecommand, then push [ENT].

```
***** Semi/Auto *****
--- 1st telecommand ---
▶J3E
F1B/J2B TTY-FEC
F1B/J2B TTY-ARD

[CH]SEL [ENT]OK
```

- ⑦ Verify your position and time, then push [ENT].
 - When the position or time requires a change, use the keypad and [CH] for settings.
 - [CH] moves the cursor.

```
***** Semi/Auto *****
--- Position & time ---

Latitude 33° 34'N
Longitude 104° 34'W
UTC 12:34

[CH]Null [CH]↔ [ENT]OK
```

- ⑧ Select the desired pre-programmed transmit and receive call frequency with [CH], then push [ENT].

```
***** Semi/Auto *****
--- Call frequency ---
▶Manual set

T: 2177.0kHz SHIP
R: 2177.0kHz
T: 2189.5kHz INTER-2
R: 2177.0kHz

[CH]SEL [ENT]OK
```

- When "Manual set" is selected, enter the desired transmit and receive call frequency via the keypad.



- ⑨ The calling stand-by screen is displayed as follows, verify the calling condition then push and hold [CALL] for 1 sec. to transmit the telephone call.
 - Push and hold [ENT] for 1 sec. to store the calling condition into the TX memory as described in pages 22 and 37, if desired.

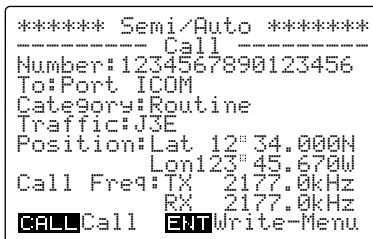

- ⑩ When the telephone call is succeeded, the following screen is displayed.
 - The transceiver repeats DSC transmissions and receptions until the frequency, which stable communication can be made, is found.
 - The transceiver selects the communication frequency, specified by the coast station, automatically.

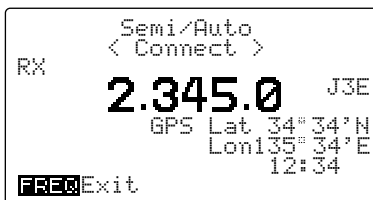

- When the telephone call is unsuccessful, "Can't connect" screen is displayed as below.



- ⑪ Communicate normal way.
 - Push and hold [PTT] to transmit; release [PTT] to receive.
- ⑫ When the communication is finished, push [FREQ/CH].
 - The transceiver sends and receipts the DSC call for disconnecting the communication.

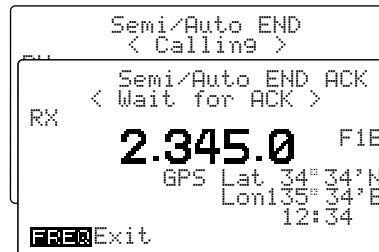

- ⑬ After the disconnection, the communicated time is displayed as below.

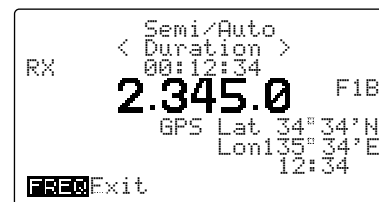

■ Test call

Testing on the exclusive DSC distress and safety calling frequencies (such as 2187.5 kHz) should be avoided as much as possible by using other methods. When testing on the distress/safety frequency is unavoidable, it should be indicated that these are test transmissions.

Normally the test call would require no further communications between the two stations involved.

- ① Push [MODE SET] to select the DSC menu.
- ② Rotate [CH] to select "Test" call, then push [ENT].
- ③ Select the desired coast station code, then push [ENT],
 - Use [CH] to select the coast station code when pre-programmed.

```
***** Test *****
----- Address ID -----
Manual set
Port ICOM 001234567
Port ABC 001234566
Port M801 001234565
[CH]SEL [ENT]OK
```

- When "Manual set," is selected, enter the desired code (last 7 digits only) via the keypad.
- The first 2 digits "00 (double zero)" are fixed for the coast station code.

```
***** Test *****
----- Address ID -----
[CH]↔ [ENT]OK
```

- ④ Select the desired call frequency, then push [ENT].
 - Use [CH] to select one of the desired distress/safety frequencies.

```
***** Test *****
----- Call frequency -----
Manual set
2187.5kHz
[CH]SEL [ENT]OK
```

- When "Manual set" is selected, enter the desired transmit and receive frequencies via the keypad.

```
***** Test *****
----- Call frequency -----
TX: 2187.5kHz
RX: 2187.5kHz
[CH]↔ [ENT]OK
```

- ⑤ The calling stand-by screen is displayed as follows, verify the calling condition then push and hold [CALL] for 1 sec. to transmit the test call.

```
***** Test *****
----- Call -----
To:Port ICOM
Category:Safety
Call Freq:TX 2187.5kHz
RX 2187.5kHz
[CALL]Call
```

- ⑥ After sending a call, the transceiver waits for an acknowledgement.

```
Test
< Wait for ACK >
2.187.5 F1B
GPS Lat 34° 34' N
Lon 135° 34' E
12:34
[FREQ]Exit
```

- ⑦ When receiving an acknowledgement, the display shows the received ID code, or ID name, if programmed.

```
*****
* Test ACK *
* ABC Port *
*****
[FREQ]Exit
```

■ To receive a DSC call

The independent built-in DSC receiver circuit in the IC-M801E scans all distress/safety frequencies, therefore, the “distress,” “urgency” and “safety” calls on those frequencies can be decoded at all times.

◇ When receiving a DSC call

One of the following actions should be performed when a DSC call is received depending on the received DSC format (or category):

- Wait for a voice transmission on the traffic frequency.
- Transmit an acknowledgement with DSC or voice.

◇ Display example and operation

•Monitoring the traffic frequency

Monitor the communication between the calling ship and a coast station, or the calling station transmission via voice on the traffic frequency.

- Emergency alarm sounds until pushing some key, or beeps sound, depending on the calling format or category.

```

*****
*   Distress RLY   *
* 123456789      *
*****

*****
*   Distress      *
* 123456789      *
*****

*****
*   Group         *
* ICOM M802      *
*****

*****
*   GeoGraphic    *
* 123456789      *
*****

[FREQ]Exit [ENT]Traffic
    
```

However, “routine” and “group” calls on the other frequencies are received via the transceiver’s receiver circuit. Therefore, the transceiver must set to DSC watch mode by pushing [DSC] to decode these calls.

•Transmit an acknowledgement

When the following DSC is received, an acknowledgement must be sent back to the calling station.

- Beeps, or an emergency alarm sounds until pushing some key, depending on the category.

```

*****
*   Individual    *
* ICOM M801      *
*****

[FREQ]Exit [ENT]Traffic
    
```

Received information

When receiving a DSC call, the received format specifier and its contents are memorized into the RX memory. Distress calls (including other calls with a distress category) are stored separately from other calls.

Up to 20 distress and up to 20 other calls can be memorized.

- ① During DSC watch mode, push [RX CLAR] to enter the received DSC memory select screen.
 - Or, push [MODE SET], rotate [CH] to select "RX memory" then push [ENT].
- ② Rotate [CH] to select the desired category from "Distress" and "Others" then push [ENT].
 - "<No data>" is displayed beside category when no received message is stored in the category.

```

***** RX memory *****
----- Select -----
▶Distress
  Others

[CH]SEL [ENT]OK
    
```

- ③ Rotate [CH] to select the desired DSC message.
 - "*" means the DSC messages have not been read.
 - "DTRS RLY" stands for distress relay.
 - **Distress memory screen**

```

***** RX memory *****
----- Select -----
▶*123456789      12:34
  111111111     23:45
  123123123     21:54

[CH]SEL [ENT]OK
    
```

• **Others memory screen**

```

***** RX memory *****
----- Select -----
▶*Individual 123456789
  *DTRS RLY  111111111
  Geographic 123123123
  Individual  123456788

[CH]SEL [ENT]OK
    
```

- ④ Push [ENT] to indicate the contents.
 - Rotate [CH] to scroll text to see hidden lines information.

```

***** RX memory *****
----- Distress -----
Distress ID:123456789
Undesignated
Position:Lat 34° 34'N
          Lon134° 34'W
          UTC 12:34
Traffic:J3E
          TX 2182.0kHz
          RX 2182.0kHz
RX Freq:TX 2187.5kHz
          RX 2187.5kHz
[CE]DEL [FREQ]Cancel [ENT]OK
    
```

- ⑤ Push [MODE SET] to return to DSC watch mode.

NOTE:

When the DSC message with "?" symbol is selected in step ③, the message "DATA ERROR" is displayed at the bottom of the line in memory contents screen in step ④.

Deleting a memory

- ➔ When the desired memory contents to be deleted are displayed as at right, push and hold [CE] for 1 sec.
 - After erasing, the receive memory select screen, as in step ④ above, is selected automatically.
 - The DSC memory, which 48 hours or more have been passed from received, can only be deleted.

```

***** RX memory *****
----- Distress -----
Distress ID:123456789
Undesignated
Position:Lat 34° 34'N
          Lon134° 34'W
          UTC 12:34
Traffic:J3E
          TX 2182.0kHz
          RX 2182.0kHz
RX Freq:TX 2187.5kHz
          RX 2187.5kHz
[CE]DEL [FREQ]Cancel [ENT]OK
    
```

■ Distress call

- ① When receiving a distress call, an emergency alarm sounds and the display below appears.

```
*****
*          Distress          *
*          123456789         *
*****
[FREQ]Exit [ENT]Traffic
```

- ② Push any key to stop the alarm, if desired.
 ③ Push [ENT] to set the transceiver to the distress phone frequency, then monitor the communication from the coast station to the ship in distress.

```

DISTRESS
RX  <Traffic>
2.182.0  J3E
      GPS Lat 34° 34' N
      Lon 135° 34' E
      12:34
[FREQ]Exit
```

- ④ Select the received distress call memory channel to check the position of the ship in distress.

- Push [FREQ/CH] then [RX CLAR] to select "RX memory" screen.
- Select "Distress" with [CH] then push [ENT].
- Push [ENT] again.

- The received distress call memory is displayed at the top line with "*" symbol.
- When the ship is close to you, communication should be monitored continuously.
- The traffic frequency is monitored even when the memory contents is displayed.

```
***** RX memory *****
----- Distress -----
Distress ID:123456789
Undesignated
Position:Lat 34° 34' N
          Lon134° 34' W
          UTC 12:34
Traffic:J3E
TX  2182.0kHz
RX  2182.0kHz
RX Freq:TX 2187.5kHz
          RX 2187.5kHz
[DEL] [FREQ]Cancel [ENT]OK
```

◇ Distress relay call operation

Distress call reception should stop after one sequence since the coast station should send back an 'acknowledgement' to the ship. If the distress call continues, the coast station may not be receiving the call. In such cases, you should contact the ship via the phone.

- ① Contact the ship in distress via the phone as below:

- "MAYDAY"
- The 9-digit identity of the ship in distress, repeated 3 times.
- "This is (your ship name)."
- Your identification, (9-digit identity, call sign or other identification), repeated 3 times.
- "RECEIVED MAYDAY."

- ② When the ship requires a 'distress relay' call or the ship appears not to reply, proceed as follows for 'distress relay' transmission.
 ③ Push [MODE SET] to select DSC menu.
- Push [DSC] to select DSC watch mode in advance, if necessary.

- ④ Rotate [CH] to select "Distress RLY" then push [ENT].

```
***** DSC MENU *****
----- Select -----
Position
Individual
Group
Position REQ
Distress
▶Distress RLY
Semi/Auto
Test
RX memory
TX memory
Set up
Self test
Exit
[CHSEL] [ENT]OK
```

➤ Continue to the next page

◇ Distress relay call operation— continued

- ⑤ Select the nearest coast station code, then push [ENT].
 - Use [CH] to select the coast station code when pre-programmed.

```
***** Distress RLY *****
----- Address ID -----
▶Manual set

Port Icom1 001234567
Port Icom2 001234568
Port Icom3 001234569

[CH]SEL [ENT]OK
```

- When “Manual set” is selected, enter the desired code (last 7 digits only) via the keypad.
 - The first 2 digits “00 (double zero)” are fixed for the coast station code.

```
***** Distress RLY *****
----- Address ID -----

0:-----

[CH]↔ [ENT]OK
```

- ⑥ Rotate [CH] to select the distress call to be relayed, then push [ENT].
 - The ship’s ID of the distress call will not be displayed once 24 hours has passed after receiving the distress call.

```
***** Distress RLY *****
----- Select -----
▶123456789
987654321
Manual set

[CH]SEL [ENT]OK
```

- When “Manual” is selected, enter the ship’s ID in distress via the keypad manually.
 - The distress relay call can be made without an ID, if the ship’s ID is unknown.

```
***** Distress RLY *****
----- Distress ID -----

Are you sure?

[CH]↔ [ENT]OK
```

- ⑦ Rotate [CH] to select the nature of distress, then push [ENT].

```
***** Distress RLY *****
----- Nature -----
▶Undesignated
Fire,Explosion
Flooding
Collision
Grounding
Capsizing
Sinking
Disable adrift
Abandoning ship
Piracy attack
Man overboard

[CH]SEL [ENT]OK
```

- ⑧ Verify the position and time of the ship’s in distress, then push [ENT].
 - When the position or time requires a change, use the keypad and [CH] for settings.
 - [CH] moves the cursor.

```
***** Distress RLY *****
--- Position & time ---

Latitude 34.343N
Longitude 134.343E
UTC 12:34

[CH]Null [CH]↔ [ENT]OK
```

- ⑨ Rotate [CH] to select the desired calling frequency, then push [ENT].

```
***** Distress RLY *****
--- Call frequency ---
▶ 2187.5kHz
4207.5kHz
6312.0kHz
8414.5kHz
12577.0kHz
16804.5kHz

[CH]SEL [ENT]OK
```

- ⑩ The calling stand-by screen is displayed as follows, verify the calling condition then push and hold [CALL] for 1 sec. to transmit the call.
 - Distress relay call should be transmitted after 5 minutes or more has passed from receiving the distress call. If the distress relay call is made within 5 minutes from receiving the distress call, the message “Alert should be answered by coast station. Please wait a few minutes.” is displayed after pushing and holding [CALL] for 1 sec.

```
***** Distress RLY *****
----- Call -----
Selected distress
call is received
11H 34min
before
To:001234567
Distress ID:123456789
Undesignated
Position:Lat 34° 34.000N
Lon134° 34.000W
UTC 12:34
Traffic:J3E
TX 2182.0kHz
RX 2182.0kHz
Call Freq:TX 2187.5kHz
RX 2187.5kHz

[CALL]Call
```

- ⑪ After sending the call, the transceiver selects the set traffic frequency automatically.

```
RX < Traffic >
2.182.0 J3E
GPS Lat 34° 34'N
Lon134° 34'E
12:34

[FREQ]Exit
```

■ Distress relay call

- ① When receiving a distress relay call, an emergency alarm sounds and the display below appears.

```
*****
*   Distress RLV   *
*   001234567     *
*****
[FREQ]Exit [ENT]Traffic
```

- ② Push any key to stop the alarm, if desired.
 ③ Push [ENT] to set the transceiver to the distress phone frequency, then monitor the communication from the coast station to the ship in distress.

```

DISTRESS
RX < Traffic > J3E
  2.182.0
    GPS Lat 34°34'N
      Lon135°34'E
        12:34
[FREQ]Exit
```

- ④ Select the received distress call memory channel to check the position of the ship in distress.
- ➔ Push [FREQ/CH] then [RX CLAR] to select "RX memory" screen.
 - ➔ Select "Others" with [CH] then push [ENT].
 - ➔ Push [ENT] again.
 - The received distress relay call memory (DTRS RLV) is displayed at the top line with "*" symbol.
 - When the ship is close to you, communication should be monitored continuously.
 - The traffic frequency is monitored even when the memory contents is displayed.

```
***** RX memory *****
----- Distress RLV -----
From:001234567
Distress ID:123456789
Undesignated
Position:Lat 34 34'N
          Lon134° 34'W
          UTC 12°34
Traffic:J3E
TX 2182.0kHz
RX 2182.0kHz
RX Freq:TX 2187.5kHz
          RX 2187.5kHz
[CE]DEL [FREQ]Cancel [ENT]OK
```

◆ Distress relay acknowledgement call operation

The distress relay acknowledgement call can be made only when distress relay call is received.

- ① After receiving a distress relay call, push [FREQ/CH] to return to DSC watch mode.
 ② Push [MODE SET] to select the DSC menu.
 ③ Rotate [CH] to select "Distress RLY ACK," then push [ENT].
 • "Distress RLY ACK" selection is available only when distress relay call is received.

```
***** DSC MENU *****
----- Select -----
Position
Individual
Group
Geographical
Distress
Distress RLV
▶Distress RLY ACK
Semi/Auto
Test
RX memory
TX memory
Set up
Self test
Exit
[CH]SEL [ENT]OK
```

- ④ Rotate [CH] to select the distress call to be replied, then push [ENT].

```
*** Distress RLY ACK ***
----- Select -----
▶001234567
007654321
[CH]SEL [ENT]OK
```

- ⑤ The calling stand-by screen is displayed as follows, verify the calling condition then push and hold [CALL] for 1 sec. to transmit the call.

```
*** Distress RLY ACK ***
----- Call -----
To:001234567
Distress ID:123456789
Undesignated
Position:Lat 34° 34'N
          Lon134° 34'W
          UTC 12:34
Traffic:J3E
TX 2182.0kHz
RX 2182.0kHz
RX Freq:TX 2187.5kHz
          RX 2187.5kHz
[CALL]Call
```

■ Semi/Auto (telephone) call

- When receiving a telephone call, beeps sound and the transceiver selects the communication frequency automatically.
 - Speak into the handset or microphone as the normal way.
 - The transceiver answers to the call to unable to reply the call automatically, according to the setting. See right column for details.

```

Semi/Auto
< Connect >
RX      2.345.0  J3E
        GPS Lat 34° 34' N
        Lon 135° 34' E
        12:34
[FREQ]Exit
    
```

- When the communication is finished, push [FREQ/CH].
 - The transceiver sends and receipts the DSC call for disconnecting the communication.

```

Semi/Auto END
< Calling >
Semi/Auto END ACK
< Wait for ACK >
RX      2.345.0  F1B
        GPS Lat 34° 34' N
        Lon 135° 34' E
        12:34
[FREQ]Exit
    
```

- After the disconnection, the communicated time is displayed as below.

```

Semi/Auto
< Duration >
RX      2.345.0  F1B
        00:12:34
        GPS Lat 34° 34' N
        Lon 135° 34' E
        12:34
[FREQ]Exit
    
```

◇ Answering condition selection

In the default setting, the transceiver connects to the telephone call automatically, that described at left. However, when the operator is in busy or leaving from the transceiver, the operator cannot be reply the call immediately. The answering condition setting is convenient for such cases.

- During DSC watch mode, push [MODE SET] to select the DSC menu.
- Rotate [CH] to select "Semi/Auto," then push [ENT].

```

***** DSC MENU *****
----- Select -----
Position
Individual
Group
Geographical
Distress
Distress RLY
Distress RLY ACK
▶Semi/Auto
Test
RX memory
TX memory
Set up
Self test
Exit
[CH]SEL [ENT]OK
    
```

- Rotate [CH] to select "Answer Setting," then push [ENT].

```

***** Semi/Auto *****
----- Action -----
Calling
▶Answer Setting
[CH]SEL [ENT]OK
    
```

- Rotate [CH] to select "Able" or "Unable" as desired.

- **Able** : The transceiver selects the communication frequency specified by the coast station, then connect to the phone call. (default)
- **Unable** : The transceiver answering to the phone call to unable to reply the call.

```

***** Semi/Auto *****
----- Answer Setting -----
Able
▶Unable
[CH]SEL [ENT]OK
    
```

- Push [ENT] to return to the DSC menu screen.

■ Group call

- ① When receiving an Group call, beeps may sound and "Group" is displayed as below.
 • Push any key to stop the beeps.

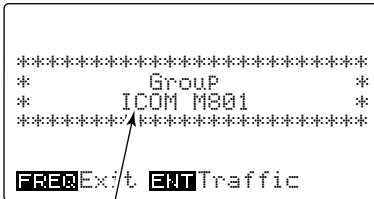

Calling station's name appear when the same ID is preprogrammed.

- ② Push [ENT] to listen to the traffic frequency for an announcement from the calling ship (mother ship in your group).



- ③ Communicate via the handset or microphone with the ship when the calling ship requires such.
 ④ Push [FREQ/CH] to return to DSC watch mode.

■ Geographical area call

NOTE: The IC-M801E will not function for the geographical call when your position is out of the specified area.

- ① When receiving a geographical area call and your position is in the specified area, "Geographic" is displayed as below.
 • Push any key to stop the beeps



- ② Push [ENT] to select the traffic frequency, and listen for an announcement from the calling station.
 • Rotate [CH] to scroll text to see the hidden lines information.

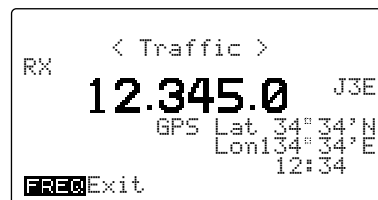

- ③ Push [FREQ/CH] to return to DSC watch mode.

Individual call

When receiving an Individual call, beeps may sound (or the emergency alarm depending on the category) and the display below appears.

```
*****
*           Individual           *
*           ICOM M801           *
*****
[FREQ]Exit [ENT]ACK
```

Calling station's name appears when the same ID is preprogrammed.

You must send back an acknowledgement to the calling station in such cases.

- When "Individual" is displayed as above, push [ENT] to display the calling contents.
 - The received call is selected in RX memory.
 - Rotate [CH] to scroll text to see hidden lines information.

```
***** RX memory *****
----- Individual -----
Category:Routine
From:ICOM M801
Traffic:J3E
TX 2345.0kHz
RX 2345.0kHz
RX Freq:TX 12345.0kHz
RX 12345.0kHz
[CE]DEL [FREQ]Cancel [ENT]ACK
```

- Push [ENT] for acknowledgement call preparation.
- Rotate [CH] to select that you can comply to the call or not from "Able" and "Unable," then push [ENT].
 - When "Able" is selected, go to step ⑤.

```
**** Individual ACK ****
----- Comply -----
▶Able
  Unable
  New traffic
[CE]DEL [FREQ]Cancel [ENT]ACK
```

When "New traffic" is selected, select or enter the desired traffic frequency, then go to step ⑤.

- When "Unable" is selected in step ③, rotate [CH] to select the desired reason, then push [ENT].

```
**** Individual ACK ****
----- Comply -----
▶No reason given
  Busy
  Channel unable
  Mode unable
  Operator unavailable
  No operator
  Station barred
  Equipment disable
  Congestion
  Queue indication
[CE]SEL [ENT]OK
```

- Push [CALL] for 1 sec. to transmit the Individual acknowledgement.

- When "Able" or "New traffic" is selected in step ③.

```
**** Individual ACK ****
----- Call -----
Category:Routine
To:ICOM M801
Traffic:J3E
TX 2345.0kHz
RX 2345.0kHz
Call Freq:TX 12345.0kHz
RX 12345.0kHz
[CALL]Call
```

- When "Unable" is selected in step ③.

```
**** Individual ACK ****
----- Call -----
Category:Routine
To:ICOM M801
Unable to comply
Reason:
  Operator unavailable
Call Freq:TX 12345.0kHz
RX 12345.0kHz
[CALL]Call
```

- After the transmission, the transceiver selects —
 - The specified traffic frequency when "Able" or "New traffic" is selected in step ③:

```
< Traffic >
RX      2.345.0 J3E
        GPS Lat 34°34'N
        Lon135°34'E
        12:34
[FREQ]Exit
```

- The DSC watch mode when "Unable" is selected in step ③.

Memory description

The IC-M801E has several kinds of memories as follows:

- Address and group ID code memories (p. 38)
- Call, traffic and scan frequency memories (p. 39)
- DSC transmission memory (described in this section)
- Received message memory (p. 30)

10 DSC transmission memory channels allow you to set often used format specifiers and contents such as for routine calls, group calls, etc.

Memory writing

- ① During DSC watch mode, select the desired format category (except distress and test), and set the message, traffic and call frequencies until the call stand-by screen is displayed as described in the CALL PROCEDURE section (pgs. 20–27).
- ② Push and hold [ENT] for 1 sec. to select the TX memory write condition.
- ③ Rotate [CH] to select the desired memory channel.

```

--- TX memory write ---
#0: Individual 987654321
#1:
#2:
#3:
#4:
#5:
#6:
#7:
#8:
#9:
[CH]SEL [ENT]Write
    
```

- ④ Push and hold [ENT] for 1 sec. again to store the condition into the selected memory channel.
 - The set DSC format and calling station ID/name appear.

```

--- TX memory write ---
#0: Individual 987654321
#1:
#2:
#3:
#4:
#5:
#6:
#7:
#8:
#9:
[CH]SEL [ENT]OK
    
```

- ⑤ Push [ENT] to return to the calling stand-by condition, or push [MODE SET] to return to DSC watch mode.

Memory reading/transmitting/deleting

- ① Push [DSC] to select DSC watch mode, if necessary.
- ② Push [TX TXF] to enter the DSC transmit memory screen.
 - Or, push [MODE SET], rotate [CH] to select "TX memory" then push [ENT], also selects the transmit memory screen.
- ③ Rotate [CH] to select the selected memory channel to be read.

```

***** TX memory *****
----- Select -----
#0: Individual 987654321
#1:
#2:
#3:
#4:
#5:
#6:
#7:
#8:
#9:
[CH]SEL [ENT]OK
    
```

- ④ Push [ENT] to display the memory contents.

```

***** TX memory *****
----- Individual -----
To: 987654321
Category: Routine
Traffic: J3E
      TX 2134.0kHz
      RX 2134.0kHz
Call Freq: TX 2187.5kHz
           RX 2187.5kHz
[CALL]Call [CE]DEL
    
```

- ⑤ Operate as follows:
 - **When reading the memory contents only;**
 - Push [MODE SET] to return to DSC watch mode.
 - **When transmitting the memory contents;**
 - Push and hold [CALL] for 1 sec.
 - **When clearing the memory contents;**
 - Push and hold [CE] for 1 sec.

10 DSC MENU OPERATION

■ General

Up to 100 ID codes with frequency and name can be programmed in MENU mode for easy recall during DSC call setting.

In addition, the following settings/operation are available in DSC setup menu.

- Manual position/time setting (p. 15)
- Self-ID (MMSI code) indication (described in this section; p. 40)

■ ID input

A total of 100 ID codes can be programmed as “Address ID” (for ships and coast stations) and “Group ID” (for group stations). A pair of frequencies (both transmit and receive) and ID name are also programmed together with the ID code which are used as call frequencies when using the ID code.

◇ SETTING PROCEDURES:

- ① During DSC menu indication, rotate [CH] to select “Set up” then push [ENT] to select setup menu.
 - The select screen is displayed as below.

```
***** Set up *****
----- Select -----
▶Address ID
  Group ID
  Call frqeuency
  Traffic frqeuency
  Scan frqeuency
  Number
  MMSI check
CHSEL ENTOK
```

- ② Rotate [CH] to select the “Address ID” or “Group ID,” then push [ENT].
 - The address/group ID list screen is displayed.

```
***** Set up *****
----- Address ID -----
***** Set up *****
----- Group ID -----
▶<add>
CHSEL FREQ Cancel ENTOK
```

When the memory is full:

“Memory full” is displayed beside “<add>” indication when 100 ID codes have been programmed.

Delete any unnecessary IDs in such cases (see p. 41 for delete).

- ③ Rotate [CH] to select “<add>” then push [ENT].
 - The address/group ID setup screen is displayed.

```
***** Set up *****
----- Address ID -----
***** Set up *****
----- Group ID -----
Name:
ID:0
TX:-----kHz
RX:-----kHz
CH↔ FREQ Cancel ENTOK
```

- ④ Push the numeral keys to input the desired 10-digit ID name, 9-digit code and both transmit and receive frequencies, then push [ENT].

- Rotate [CH] to move the cursor.
- When entering group code, enter “0 (zero)” for the first digit.

- The frequencies entered should be within the marine frequency ranges as follows.

1.6– 2.9999 MHz	4.0– 4.9999 MHz
6.0– 6.9999 MHz	8.0– 8.9999 MHz
12.0–13.9999 MHz	16.0–17.9999 MHz
18.0–19.9999 MHz	22.0–22.9999 MHz
25.0–27.5000 MHz	

```
***** Set up *****
----- Address ID -----
***** Set up *****
----- Group ID -----
Name: ICOM M801
ID: 012345678
TX: 2345.0 kHz
RX: 2345.0 kHz
CH↔ FREQ Cancel ENTOK
```

- ⑤ Push [ENT] to program the contents into the address or group ID.

- Returns to the address/group ID list screen automatically.

- The ID list is displayed in alphabetical order for ID name, so [CH] rotation may be necessary for the programmed ID confirmation.

```
***** Set up *****
----- Address ID -----
***** Set up *****
----- Group ID -----
▶<add>
ICOM M801 012345678
CHSEL FREQ Cancel ENTOK
```

- ⑥ Push [MODE SET] to return to DSC watch mode, or push [FREQ/CH] to return to the select screen.

Frequency input

A total of 50 frequency pairs can be programmed as “Call frequency,” “Traffic frequency” or “Scan frequency.” The frequency usage and frequency name are also programmed together with the frequency.

NOTE: Up to 6 pairs of frequencies only can be assigned as a scan frequency. They are scanned during DSC watch mode only. (Different from the distress/safety frequencies.)

SETTING PROCEDURES:

- ① During DSC menu indication, rotate [CH] to select “Set up” then push [ENT] to select setup menu.
 - The select screen is displayed.
- ② Rotate [CH] to select the “Call frequency” “Traffic frequency” or “Scan frequency,” then push [ENT].
 - The call/traffic/scan frequency list screen is displayed.

```

***** Set up *****
---- Call frequency ----

***** Set up *****
-- Traffic frequency ---

***** Set up *****
---- Scan frequency ----
<add>

CHSEL FREQ Cancel ENT OK
    
```

When the memory is full:

“Memory full” is displayed beside “<add>” indication when a total of 50 pairs of frequencies (6 pairs for scan frequency) have been programmed.

Delete any unnecessary frequency in such cases (see p. 41 for delete).

- ③ Rotate [CH] to select “<add>” then push [ENT].
 - The call/traffic/scan frequency setup screen is displayed.

```

***** Set up *****
---- Call frequency ----

***** Set up *****
-- Traffic frequency ---

***** Set up *****
---- Scan frequency ----

Comment:
TX: : kHz
RX: : kHz

CH<+> FREQ Cancel ENT OK
    
```

- ④ Push the numeral keys to input the desired 10-character frequency name, and both transmit and receive frequencies, then push [ENT].
 - Rotate [CH] to move the cursor.
 - The frequencies entered should be within the marine frequency ranges as follows.

- | | |
|------------------|------------------|
| 1.6– 2.9999 MHz | 4.0– 4.9999 MHz |
| 6.0– 6.9999 MHz | 8.0– 8.9999 MHz |
| 12.0–13.9999 MHz | 16.0–17.9999 MHz |
| 18.0–19.9999 MHz | 22.0–22.9999 MHz |
| 25.0–27.5000 MHz | |

```

***** Set up *****
---- Call frequency ----

***** Set up *****
-- Traffic frequency ---

***** Set up *****
---- Scan frequency ----

Comment: ICOM Group
TX: 4567.0kHz
RX: 4567.0kHz

CH<+> FREQ Cancel ENT OK
    
```

- ⑤ Push [ENT] to program the contents into a call, traffic or scan frequency.
 - Returns to the call/traffic/scan frequency list screen.
 - The programmed frequency is displayed at the bottom line, so [CH] rotation is necessary for the programmed frequency confirmation.

```

***** Set up *****
---- Call frequency ----

***** Set up *****
-- Traffic frequency ---

***** Set up *****
---- Scan frequency ----
<add>

T: 4567.0kHz ICOM Group
R: 4567.0kHz

CHSEL FREQ Cancel ENT OK
    
```

- ⑥ Push [MODE SET] to return to DSC watch mode, or push [FREQ/CH] to return to the select screen.

■ Verifying self-ID

- ➔ During setup select menu indication, rotate [CH] to select "MMSI check" then push [ENT] to display the programmed MMSI ID (self-ID).
- ➔ Push [DSC] to select DSC watch mode.
- ➔ Push [MODE SET] to select DSC menu.
- ➔ Rotate [CH] to select "Set. up" then push [ENT].
- Push [MODE SET] to return to DSC watch mode, or push [FREQ/CH] to return to the select screen.

```

***** Set up *****
----- MMSI check -----

ID:123456789

[FREQ]Cancel [ENT]OK
    
```

■ Self testing

According to regulations, the IC-M801E has a self testing capability to check the internal AFSK encoder and decoder circuits without signal transmission via the transceiver.

- ① During DSC watch mode, push [MODE set] to select DSC menu.
- ② Rotate [CH] to select "Self test" then push [ENT] to start the self test.

```

***** Self test *****

Testing...

[FREQ]Cancel [ENT]OK
    
```

- ③ "OK" is displayed when both encoder and decoder functioning correctly.

```

***** Self test *****

OK

[FREQ]Cancel [ENT]OK
    
```

If the circuit has a problem, the following message is displayed.

- Both or either message is/are displayed depending on problem.
- DSC-RX NG : DSC receiver's decoder circuit has a problem.
- TRANSC NG : Transceiver's encoder or decoder circuit has a problem.

```

***** Self test *****

DSC-RX NG
TRANSC NG

[FREQ]Cancel [ENT]OK
    
```

■ Telephone number input

- ① During DSC menu indication, rotate [CH] to select "Set. up" then push [ENT] to select setup menu.
 - The select screen is displayed.
- ② Rotate [CH] to select the "Number," then push [ENT].
 - The telephone number list screen is displayed.
 - 10 telephone number memories are available.

```

***** Set up *****
----- Number -----
-><add>

Test1
1234567890123456
Test2
6543210987654321
[CH]SEL [FREQ]Cancel [ENT]OK
    
```

- ③ Rotate [CH] to select "<add>" then push [ENT].
 - The call/traffic/scan frequency setup screen is displayed.

```

***** Set up *****
----- Number -----

Name>☀️_____
Number>_____

[CH]↔ [FREQ]Cancel [ENT]OK
    
```

- ④ Push the numeral keys to input the desired 10-character telephone number name, and telephone number, then push [ENT].
 - Rotate [CH] to move the cursor.

Memory reading/deleting

- ① During setup select menu indication, rotate [CH] to select the desired memory item then push [ENT].
 - Push [DSC] to select DSC watch mode.
 - Push [MODE SET] to select DSC menu.
 - Rotate [CH] to select "Set. up" then push [ENT].
- ② Rotate [CH] to select the desired memory, then push [ENT].

```

***** Set up *****
----- Address ID -----
***** Set up *****
----- Group ID -----

Name: ICOM M801
ID: 012345678
TX: 2345.0kHz
RX: 2345.0kHz

[DEL] [ENT]OK

```

```

***** Set up *****
----- Call frequency -----
***** Set up *****
----- Traffic frequency -----
***** Set up *****
----- Scan frequency -----

Comment: ICOM Group
TX: 4567.0kHz
RX: 4567.0kHz

[DEL] [ENT]OK

```

- ③ Operate as follows:

- **When reading the memory contents only;**
 - Push [ENT] to return to the appropriate memory list screen.
- **When deleting the memory contents;**
 - Push and hold [CE] for 1 sec.
 - After deleting, the appropriate memory list screen is displayed automatically.

Printing out the DSC memory contents

The received DSC call contents can be printed out when a printer (IBM® centronics or compatible) is connected to the transceiver.

The automatic print out capability when a DSC call is received is available in initial set mode. (p. 46)

- ① Select the desired received DSC memory as described in "Received information" (p. 30).
 - During DSC watch mode, push [RX CLAR] to enter the received DSC memory select screen.
 - Or, push [MODE SET], rotate [CH] to select "RX memory" then push [ENT].
 - Rotate [CH] to select the desired category from "Distress" and "Others" then push [ENT].
 - "<No data>" is displayed beside category when no received message is stored in the category.
 - Rotate [CH] to select the desired DSC message.
 - "*" means the DSC messages have not been read.
 - "DTRS RLY" stands for distress relay.
- ② Push [ENT] to indicate the contents.

- ③ After pushing [F], push [8 PRN] for 1 sec. to print out the selected DSC memory contents.

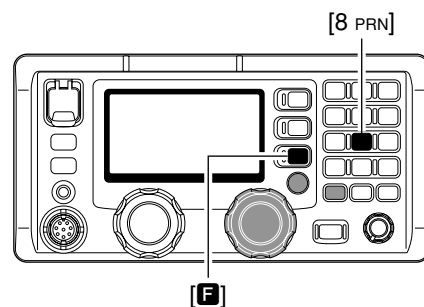

■ Quick set mode

◇ Entering quick set mode

- ① Push [F] then [MODE SET] to enter quick set mode.
 - Select voice or e-mail operation mode in advance.
- ② Rotate [GRP] to select the desired item.
- ③ Rotate [CH] to set the values or conditions for the selected item.
- ④ Push any key to exit quick set mode.

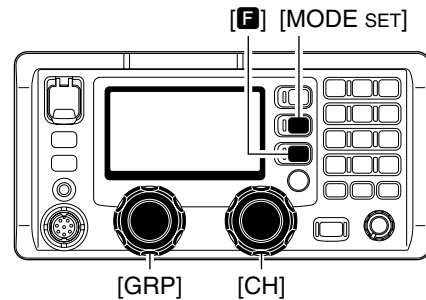

◇ Quick set mode items

Noise blanker level

This item adjusts the noise blanker level to protect a signal from various pulse-type noises from 1 to 10.
(default: 5)

The set level is effective when the noise blanker is activated.



Squelch level

This item adjusts the squelch threshold level from 1 to 100.
(default: 30)

When the squelch is activated, signals stronger than this set level only are received.

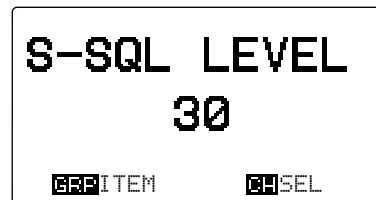

Dimmer

This item sets the LCD backlight brightness for dimmer selection from 0 (dark) to 10 (bright).

By pushing [F] then [0 DIM], the set brightness is selected to provide easy visibility during night time operation, etc.
(default: 6)

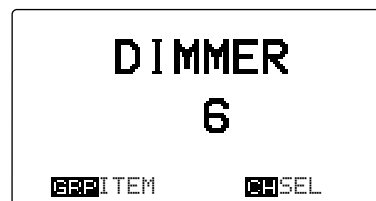

LCD contrast

This item sets the LCD contrast from 1 to 10.
(default: 7)



■ Initial set mode

Initial set mode operation is used for programming infrequently changed values, conditions or functions.

◇ Entering set mode

- ① Turn the power OFF, if the transceiver is powered ON.
- ② While pushing [MODE SET], push [POWER] to turn the power ON to enter initial set mode.
- ③ Rotate [GRP] to select the desired item.
- ④ Rotate [CH] to set the values or conditions for the selected item.
- ⑤ Turn the power OFF and ON again to exit set mode.

NOTE: Selection of some of the set mode items described here are not available on some transceiver versions.

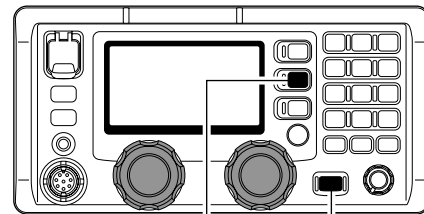

[MODE SET] [POWER]

◇ Initial set mode items

Number of user channels

This item sets the number of user channels. Up to 160 channels can be set. (default: 160)

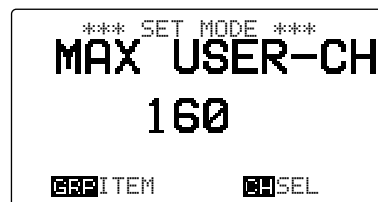

FSK ITU channel selection

This item sets the capability of the ITU channels for FSK from ON and OFF. This item will not appear when ITU channels are inhibited. (default: ON)

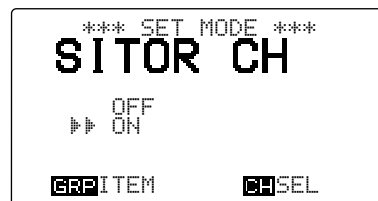

Automatic tune

When an optional automatic antenna tuner is connected, tuning can be started automatically without pushing [TUNE THRU], for instant operation.

If manual tuning is required, this automatic operation can be deactivated. (default: OFF)



Scan type

This item selects one of the following scan functions.

Programmed scan searches signals within the frequency range and activates slowly while squelch is open and fast while squelch is closed.

Channel scan and channel resume scan searches 20 channels around a user selected channel, or searches all ITU channels in the band when an ITU channel is selected. (default: CH SCAN)

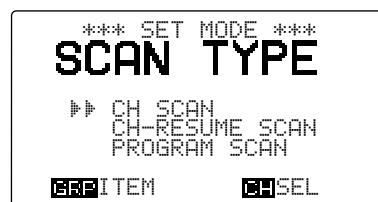

◆ Initial set mode items (continued)

Scan speed

This item adjusts the scan speed (rate at which channels are searched). The scan speed can be set from 1 to 10 with "1" being the fastest and "10" being the slowest. (default: 4)



Display type

The upper half of the display can be set to display a programmable channel name or a receive frequency according to your needs. (default: CH-NAME)



J2B filter

Select the IF filter passband width for J2B mode operation from wide, mid and narrow.

- WIDE : 2.4 kHz
- MIDDLE : 1.0 kHz
- NARROW : 500 Hz (default)



F1B filter

Select the IF filter passband width for F1B mode operation from normal and narrow.

- WIDE : 1.0 kHz
- NARROW : 500 Hz (default)



FSK tone frequency

Several mark frequencies are used for FSK operation. This item selects an FSK mark frequency for almost any FSK system from 1200 Hz, 1275 Hz, 1487.5 Hz, 1615 Hz, 2100 Hz and 2125 Hz. (default: 1615Hz)



FSK shift frequency

Several shift frequencies are used for FSK operation. This item selects an FSK shift frequency for almost any FSK system from 850 Hz, 425 Hz, 200 Hz and 170 Hz. (default: 170Hz)

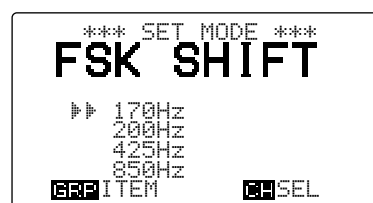

◇ Initial set mode items (continued)

FSK polarity

Normal and reverse polarities are available for FSK operations. This item allows you to select one of these polarities.

- **NORMAL** : Key open=space; Key close=mark (default)
- **REVERSE** : Key open=mark; Key close=space

```

*** SET MODE ***
FSK POLARITY
  ▶▶ NORMAL
    REVERSE
GRP ITEM      CHSEL
  
```

CW break-in function

The CW break-in function (in A1A mode) toggles transmit and receive with CW keying. Full break-in allows you to receive signals between transmitted keying pulses during CW transmission. Semi break-in allows you to mute receiving until keying stops with some delay time. (default: FULL)

```

*** SET MODE ***
CW BREAK-IN
  ▶▶ OFF
    DELAY
    FULL
GRP ITEM      CHSEL
  
```

Microphone keys

This item activates/deactivates the keys on the optional HM-135 HAND MICROPHONE ([P], [▲] and [▼]). Refer below on how to program the [P] key. (default: OFF)

```

*** SET MODE ***
MIC KEY
  ▶▶ OFF
    ON
GRP ITEM      CHSEL
  
```

[P] key function

This item assigns a function to the [P] key on the optional HM-135 HAND MICROPHONE to activate it the same as if making the key operation for [TUNE THRU], [MODE SET], [F]+[1 NB], [F]+[2 SQL], [F]+[3 SCAN], [F]+[4 SP^x] or [F]+[5 AGC^x]. (default: MODE)

```

*** SET MODE ***
P KEY
  ▶▶ TUNE
    MODE
    NB
    SQL
GRP ITEM      CHSEL
  
```

Voice squelch

This item turns the voice squelch function ON and OFF when operating in J3E and H3E modes. When the function is set to OFF, the squelch acts as an S-meter squelch for J3E and H3E modes. (default: ON)

```

*** SET MODE ***
VOICE SQL
  ▶▶ OFF
    ON
GRP ITEM      CHSEL
  
```

REMOTE ID

This item selects the ID for the transceiver from 1 to 99. (default: 11)

```

*** SET MODE ***
REMOTE ID
  11
GRP ITEM      CHSEL
  
```

◆ Initial set mode items (continued)

REMOTE connector interface

This item selects the interface format for [REMOTE] connector. (default: NMEA)

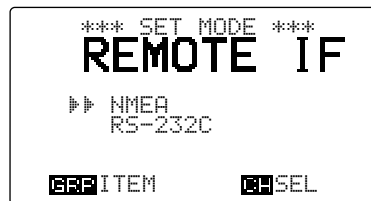

Modulation input/output selection

This item selects the input/output terminal for signals to/from an external unit, such as a TNC (Terminal Node Controller). (default: AF/MOD)



ACC out

This item toggles signal output from [AF/MOD] (pins 6–8; KEY, 13.6 V and ALC signals) ON and OFF.

- OFF : No signal is output from pins 6–8 of [AF/MOD]. (default)
- ON : KEY, 13.6 V and ALC signals are output from pins 6–8, respectively.

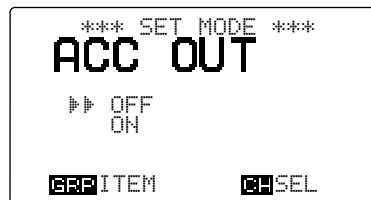

Position indication type

Select the position indicating type from simple and detail.

- SIMPLE : Hides second digits (default)
- DETAIL : Shows second digits

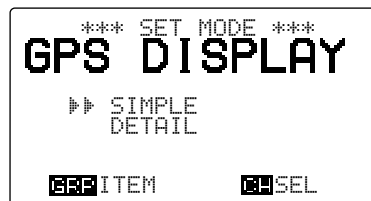

Offset time

Set the offset time between the UTC and local time within –12:00 to +12:00 in 10 minutes steps. (default: 0:00)



Automatic print out

This item turns the automatic print out function ON and OFF when receiving a DSC call.

- OFF : Prints out the received DSC contents manually.
- ON : Prints out the received DSC contents automatically. (default)



DSC data out

This item selects the DSC and DSE data output to the connected external unit, such as PC, plotter, to [REMOTE] when receiving a DSC call.

- **OFF** : No data is output even when a DSC call is received. (default)
- **ADDRESS ID** : DSC and DSE data is output when the DSC call includes the set MMSI or group code is received,
- **ALL** : DSC and DSE data is output when a DSC call is received, even the call for other stations.



12 CONNECTION AND INSTALLATION

■ Supplied accessories

The following accessories are supplied with IC-M801E.

- ① Handset 1
- ② External speaker 1
- ③ Mounting bracket kit for remote controller ... 1 set
- ④ Mounting bracket kit for speaker 1 set
- ⑤ Mounting angles for main unit 1 set
- ⑥ DC power cable (Red and Black) 1 pair
- ⑦ RCA cable (for GPS connection) 1
- ⑧ Remote control cable (OPC-1466) 1
- ⑨ Hex head bolts (M6×50) 6
- ⑩ Hex head bolts (M6×15) 6
- ⑪ Spring washers (M6) 18
- ⑫ Flat washers (M6) 18
- ⑬ Hex nuts (M6) 6
- ⑭ Spare fuses (FGB 5 A) 2
- ⑮ Weatherproof caps 2
- ⑯ Tuner connector kit 1 set

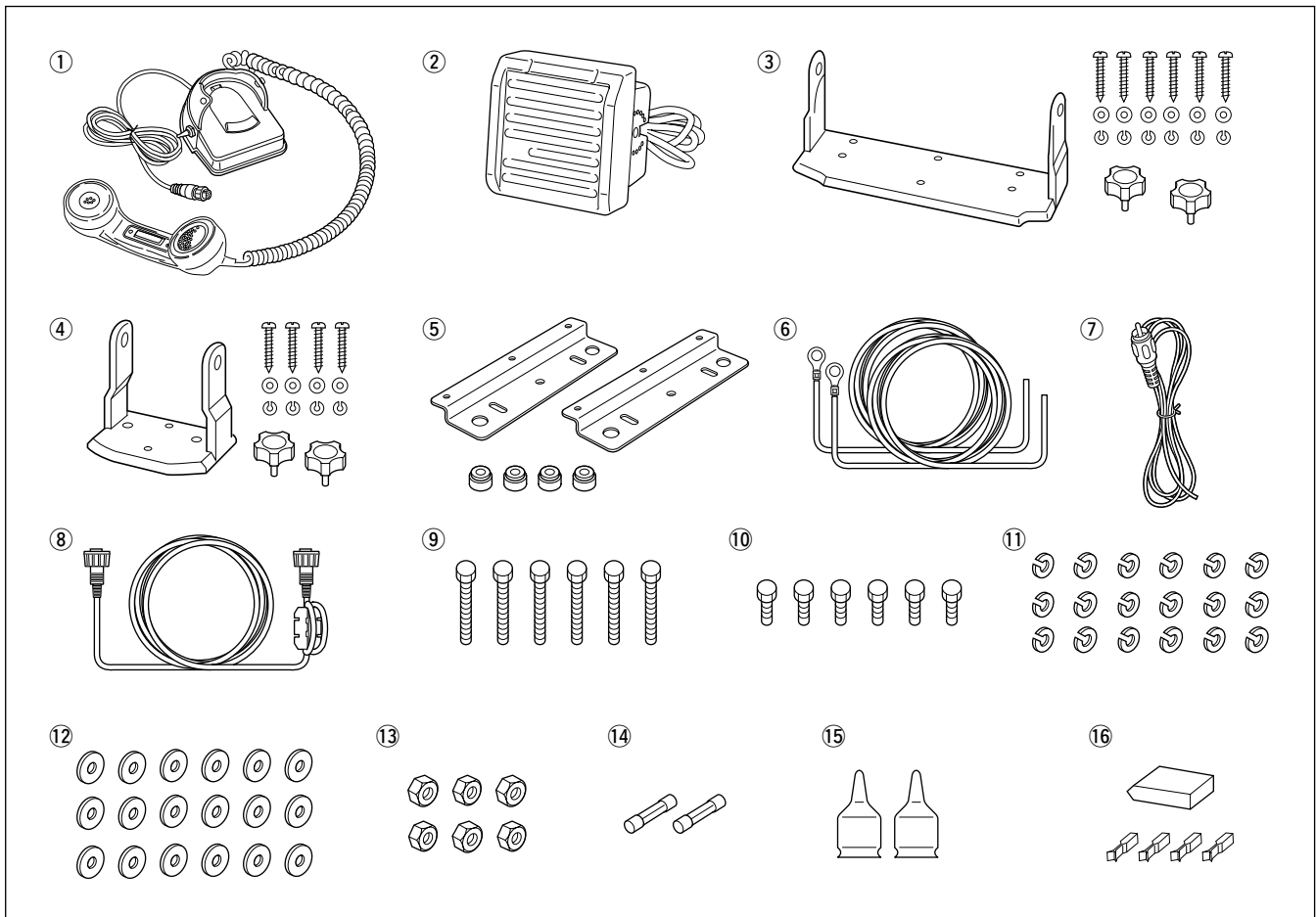

Basic connections

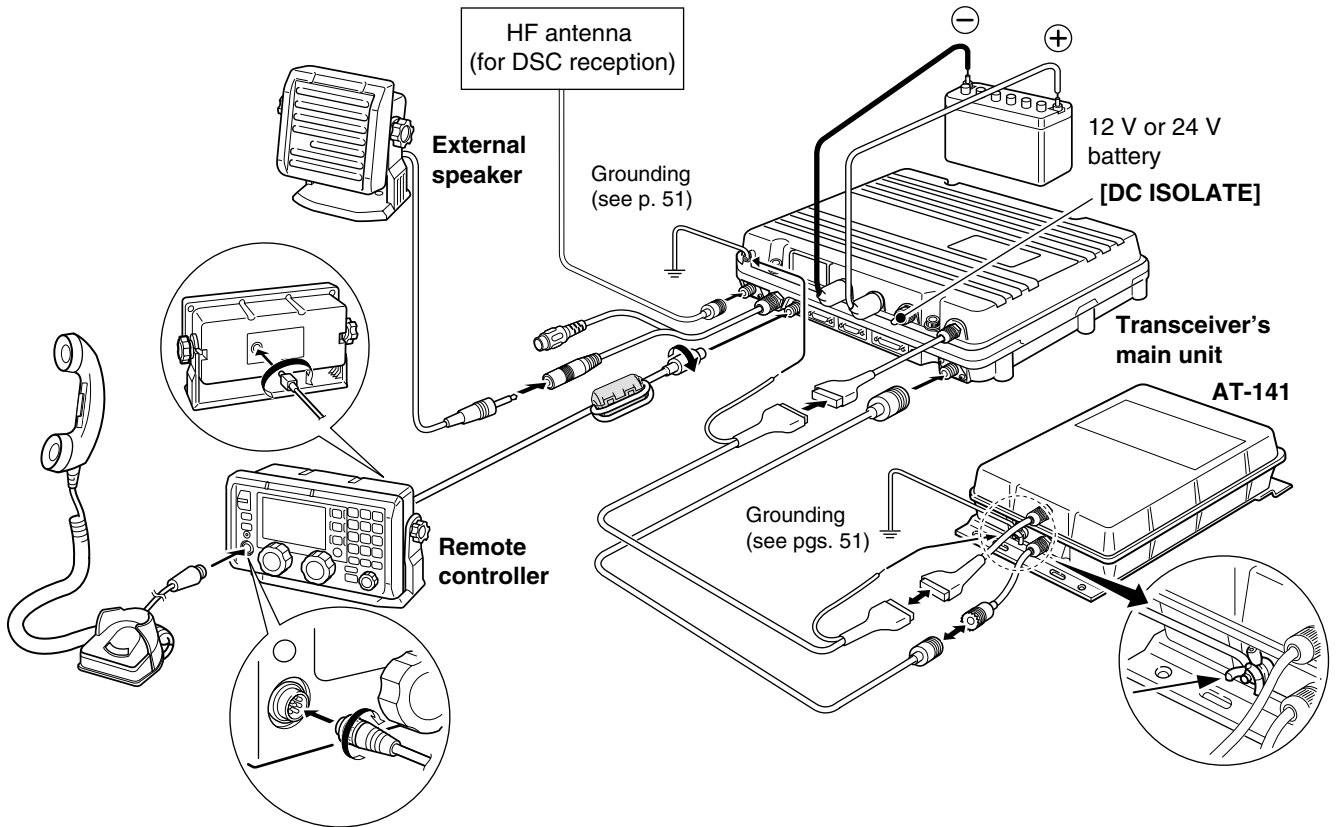

CAUTION:

- After connecting the external speaker, antenna and tuner control cables, cover the connectors with a rubber vulcanizing tape, etc., as shown below, to prevent water seeping into the connector.

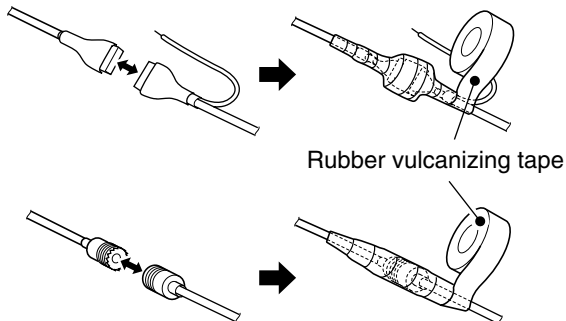

- **DO NOT** pull the antenna and control cable receptacles. This may cause cable disconnection (in the tuner unit), inside connector damaged or a bad connection.

NOTE:

- Turn [DC ISOLATE] (on the IC-M801E main unit) OFF, or charge the battery during anchor, otherwise the battery may be exhausted.
- The IC-M801E has a high-stability oven-heater type crystal oscillator, and the oscillator's heater is connected to the DC power terminals directly, it keeps its temperature to at the specified level even if the transceiver power with the remote controller has turned OFF.

■ Advanced connections

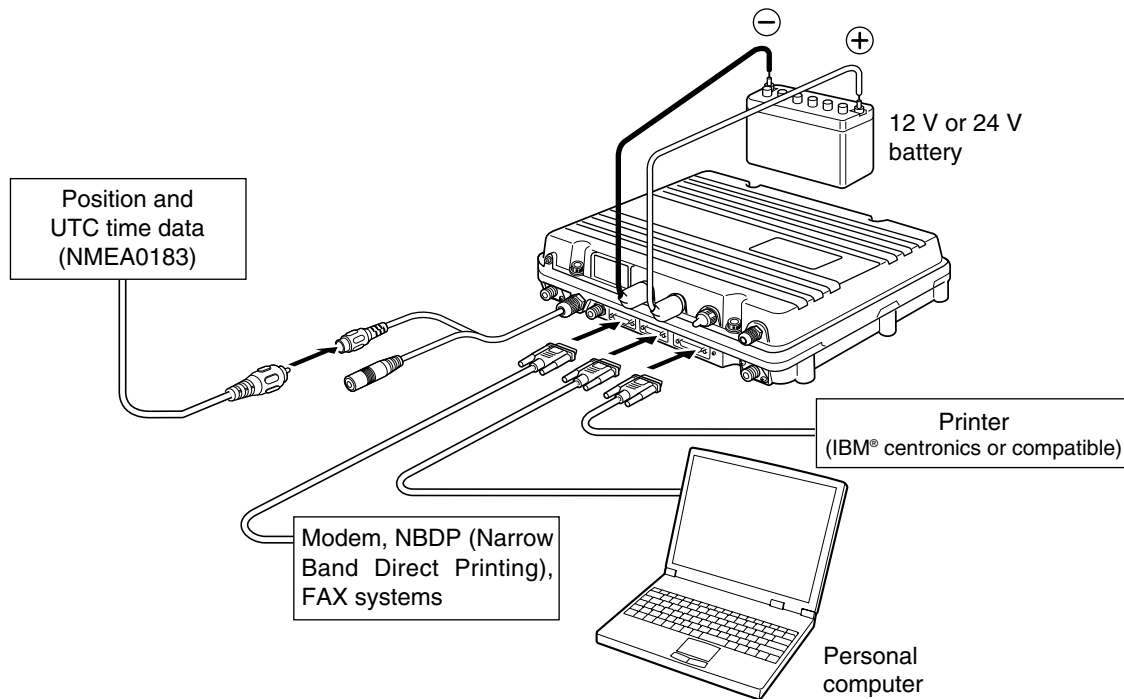

CAUTION: Any connected external unit, such as PC, printer, etc., must be properly grounded. We suggest using a wide copper strap. (p. 51)

- When a PC is connected, the PC being operated at any given time has priority.
- When a PC is connected, the controller not being operated is inhibited for a specified time after the PC is operated. This time can be programmed by your dealer. The default inhibit time is 5 sec.
- When a PC is connected, operating the PC automatically updates settings on the controller.

■ Ground connection

The transceiver and antenna tuner MUST have an adequate RF ground connection. Otherwise, the overall efficiency of the transceiver and antenna tuner installation will be reduced. Electrolysis, electrical shocks and interference from other equipment could also occur.

For best results, use 50 or 75 mm (2 or 3 inches) wide copper strap and make the connection as short as possible. Ground the transceiver and antenna tuner to one ground point, otherwise the voltage difference (in RF level) between 2 ground points may cause electrolysis.

⚠ WARNING— When grounding to a metal hull
 Use Zinc anodes to protect the hull from electrolysis.
 Ask your technical dealer, installer or refer to a technical book, etc., for RF grounding details.

⚠ CAUTION: NEVER connect the transceiver to a “positive-grounded ship,” otherwise the transceiver will not function.

Best ground points

- External ground plate
- Copper screen
- Copper foil

Acceptable ground point

- Stainless steel stanchion
- Through mast
- Through hull
- Metal water tank

Undesirable ground points

- Engine block
- Ship’s DC battery ground

Un-usable ground points

- (these connections may cause an explosion or electrical shock)
- Gas or electrical pipe
 - Fuel tank or oil-catch pan

Ground system example

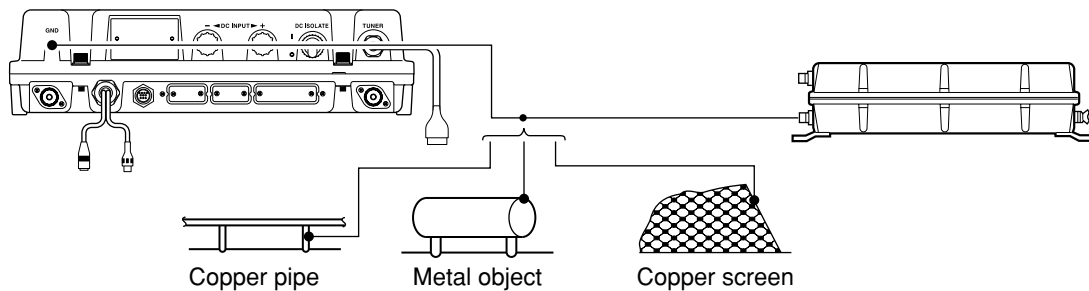

■ Power source

The transceiver requires a regulated DC power of 13.2 V and at least 60 A, or 26.4 V and at least 30 A, depending on version.

- Direct connection to a 12 V or 24 V battery in your ship through the supplied DC power cable.

⚠ WARNING! NEVER connect the transceiver to a battery using reverse polarity. This will damage the transceiver.

⚠ CAUTION: Before connecting the transceiver main unit to a battery, make sure the transceiver input voltage suits to the battery voltage.

DC power cable connection

⚠ NOTE: Use terminals for the cable connection.

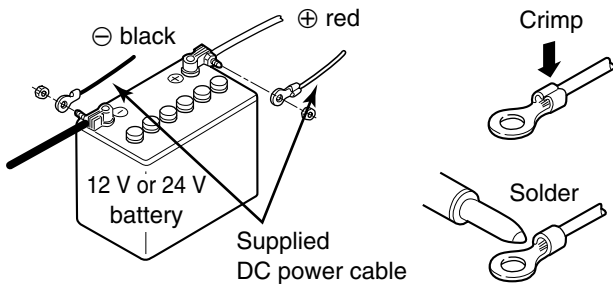

• Weatherproof cap attachment

Attach the supplied weatherproof cap for each positive and negative line at the DC power terminal as shown below.

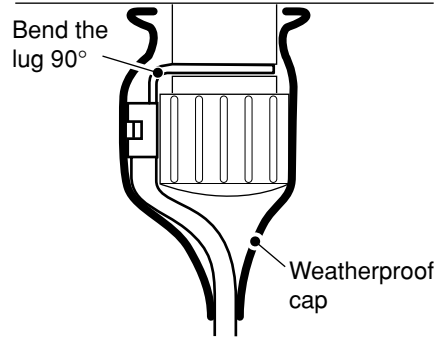

■ Antenna

Most stations operate with a whip or long wire (insulated backstay) antenna. However, these antennas cannot be connected directly to the transceiver since their impedance will not be matched with the transceiver antenna connector.

⚠ DANGER: HIGH VOLTAGE!

⚠ NEVER touch the antenna element/wire while tuning or transmitting.

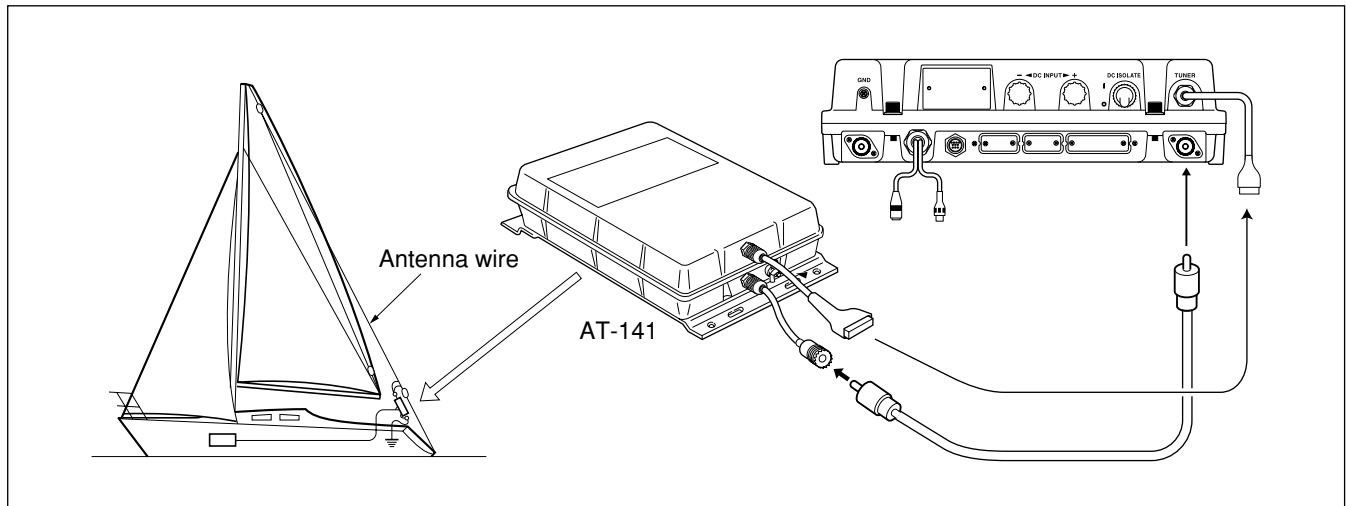

■ Mounting

◇ Mounting location

Select a location that provides easy access to the controller for navigation safety, has good ventilation and is not subject to sea spray. The controller should be at 90 degrees to your line of sight when operating it.

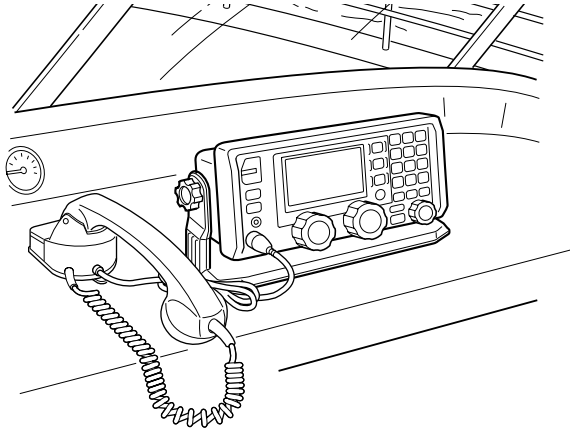

CAUTION: KEEP the transceiver and handset or microphone at least 1 meter away from your ship's magnetic navigation compass.

Check the installation angle; the display may not be easy to read at some angles.

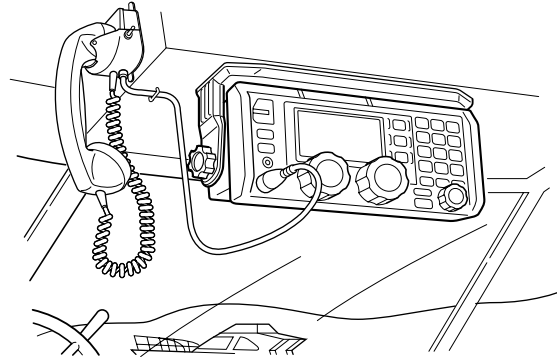

◇ Mounting the controller/speaker

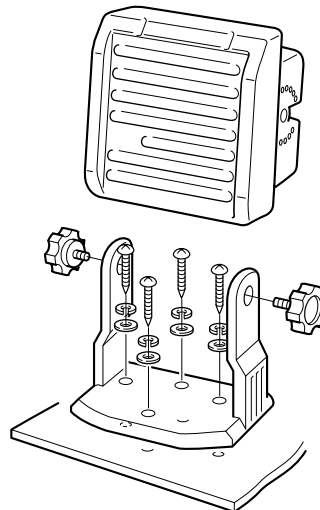
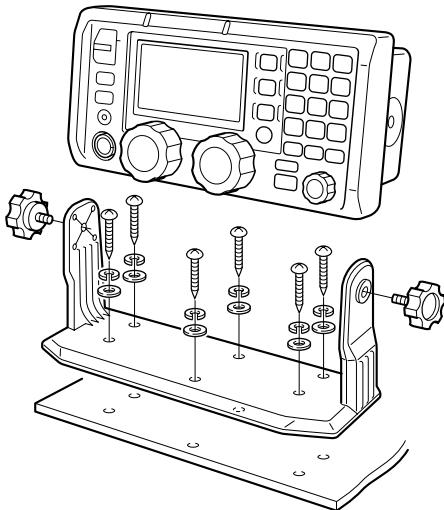

◆ **Mounting angle attachment**

① Attach the supplied rubber feet to the mounting angle, if desired.

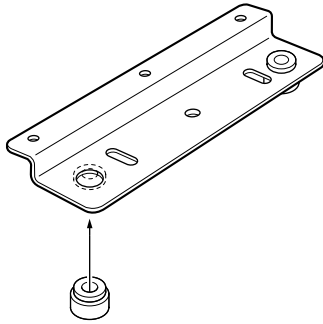

② Attach the mounting angles using with the supplied hex head bolts (M6×15), flat and spring washers as illustrated below.

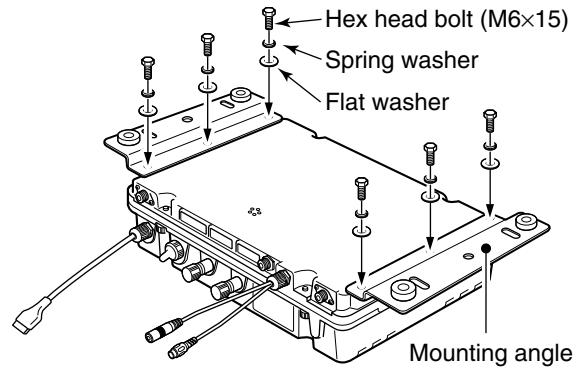

◆ **Mounting the main unit**

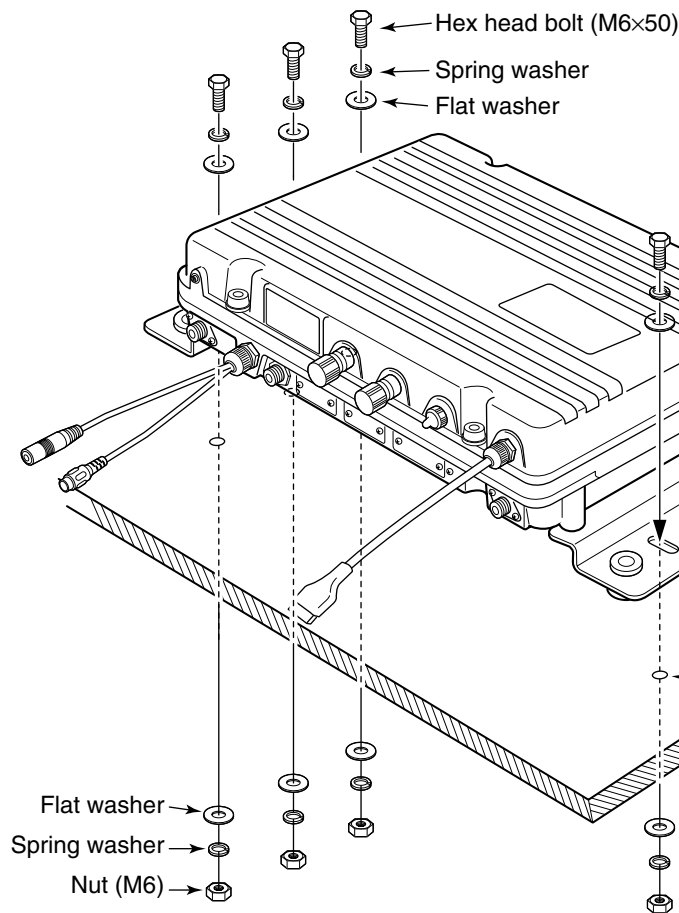

⚠ WARNING! NEVER mount the transceiver main unit overhead. The weight of the unit is approximately 8.5 kg, but its apparent weight will increase several fold due to wave shocks or vibration. The unit must be mounted on a flat hard surface only.

Drill six holes of 6 mm (¼ in) in diameter.

■ Using the optional MB-108

The optional MB-108 mounting bracket is available for mounting the transceiver's main unit. The MB-108 allows you to one-touch attachment/detachment capabilities.

CAUTION! WEAR GLOVES when installing the MB-108.
Edges of the MB-108 may be sharp and may easily cut your fingers, hands, etc.

- ① Attach the mounting handles with the supplied hex head bolts (M6×15), spring and flat washers as below.

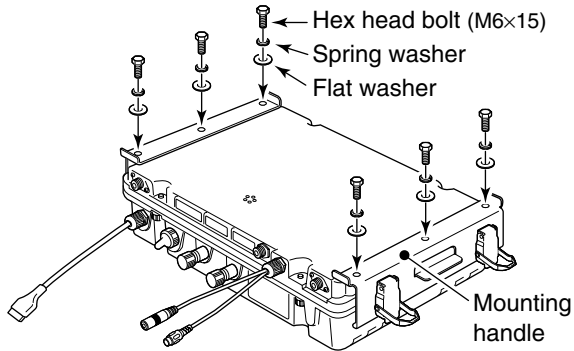

- ② Drill 7 holes of 6–8 mm ($\frac{1}{4}$ – $\frac{5}{16}$ in) in diameter, using the template supplied with the MB-108.
- ③ Attach the mounting base onto a flat surface using with the hex head bolts (M6×50), spring and flat washers, and nuts, supplied with the MB-108, as below.

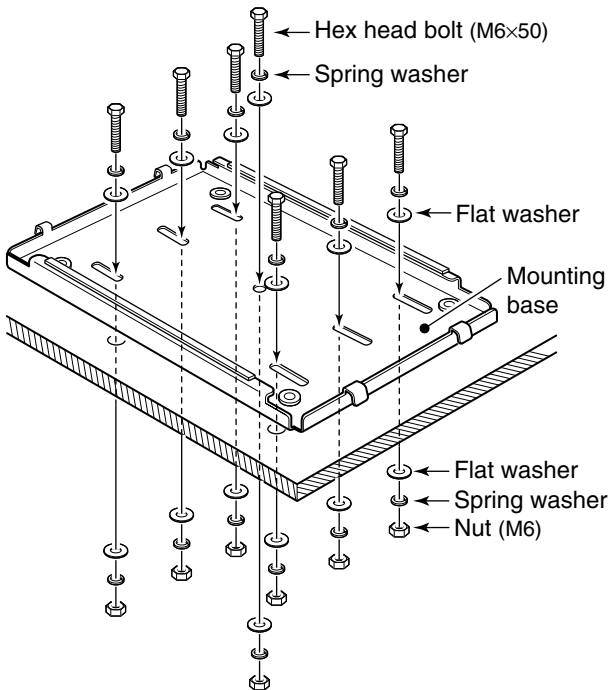

- ④ Mount the transceiver main unit (mounting handles has attached) onto the mounting base.

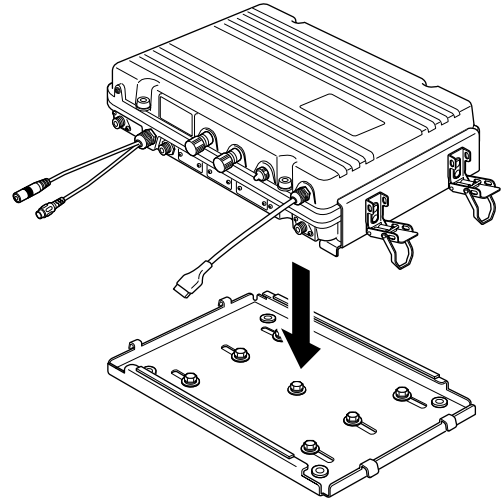

- ⑤ Fix the main unit by locking 4 latches on the mounting handles.

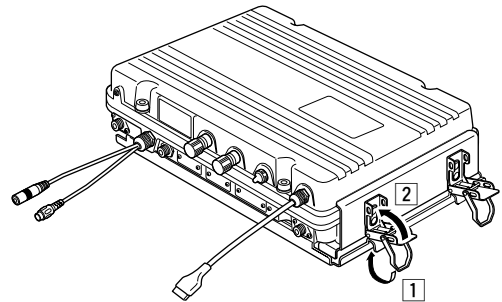

■ Using the optional MB-75

The optional MB-75 flush mount is available for mounting the controller and speaker to a flat surface such as an instrument panel.

CAUTION: KEEP the transceiver and handset or microphone at least 1 meter away from your ship's magnetic navigation compass.

- ① Using the template on the page 65 for the remote controller (RC-25E), and page 67 for the speaker (SP-24E), carefully cut a hole into the instrument panel (or wherever you plan to mount the controller or the speaker).
- ② Slide the controller or the speaker through the hole as shown below.

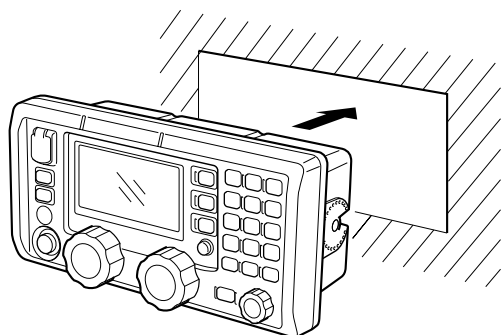

- ③ Attach the supplied 2 screws (M5×8) and spacers on either side of the controller or speaker.
- ④ Attach the clamps on either side of the controller or speaker.
 - Make sure that the clamps align parallel to the body.

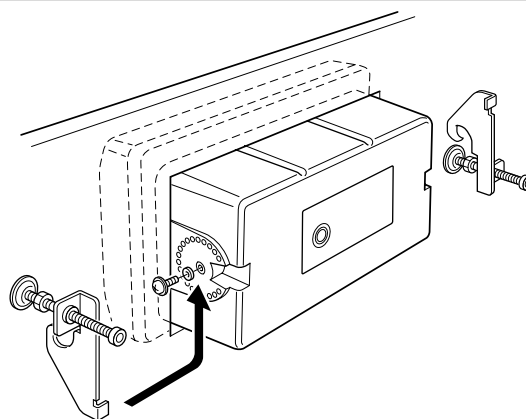

- ⑤ Tighten the end screws on the clamps (rotate clockwise) so that the clamps press firmly against the inside of the instrument control panel.
- ⑥ Tighten the locking nuts (rotate counterclockwise) so that the controller or speaker is securely mounted in position as below.
- ⑦ Connect the control cable then return the instrument control panel to its original place.

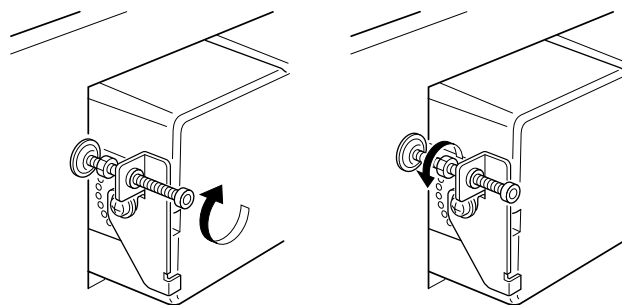

✓ For your reference

When flush mounting the controller and speaker side by side as below, screw and spacer attachment for the facing side will be impossible with the instructions above.

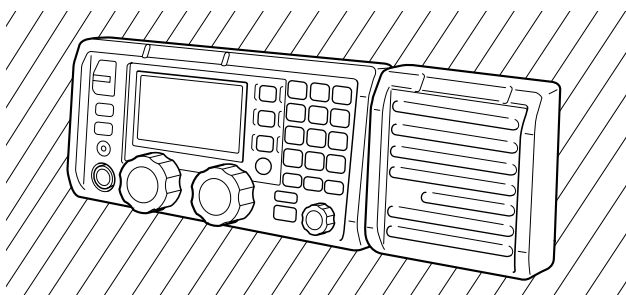

In this case, refer to the instructions at right for reference.

- ① Carefully cut the holes with at least 25 mm (1 in) space between them into the instrument panel.
- ② Install the speaker as instructed above, first.
- ③ Attach the screw and spacer on the speaker side of the controller.
- ④ Slide the controller through the hole as shown below.

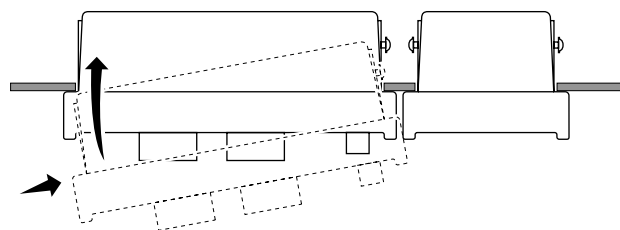

- ⑤ Attach the screw and spacer on the other side of the controller, then attach the clamps and follow steps ⑤ to ⑦ as above.

■ Transceiver dimensions

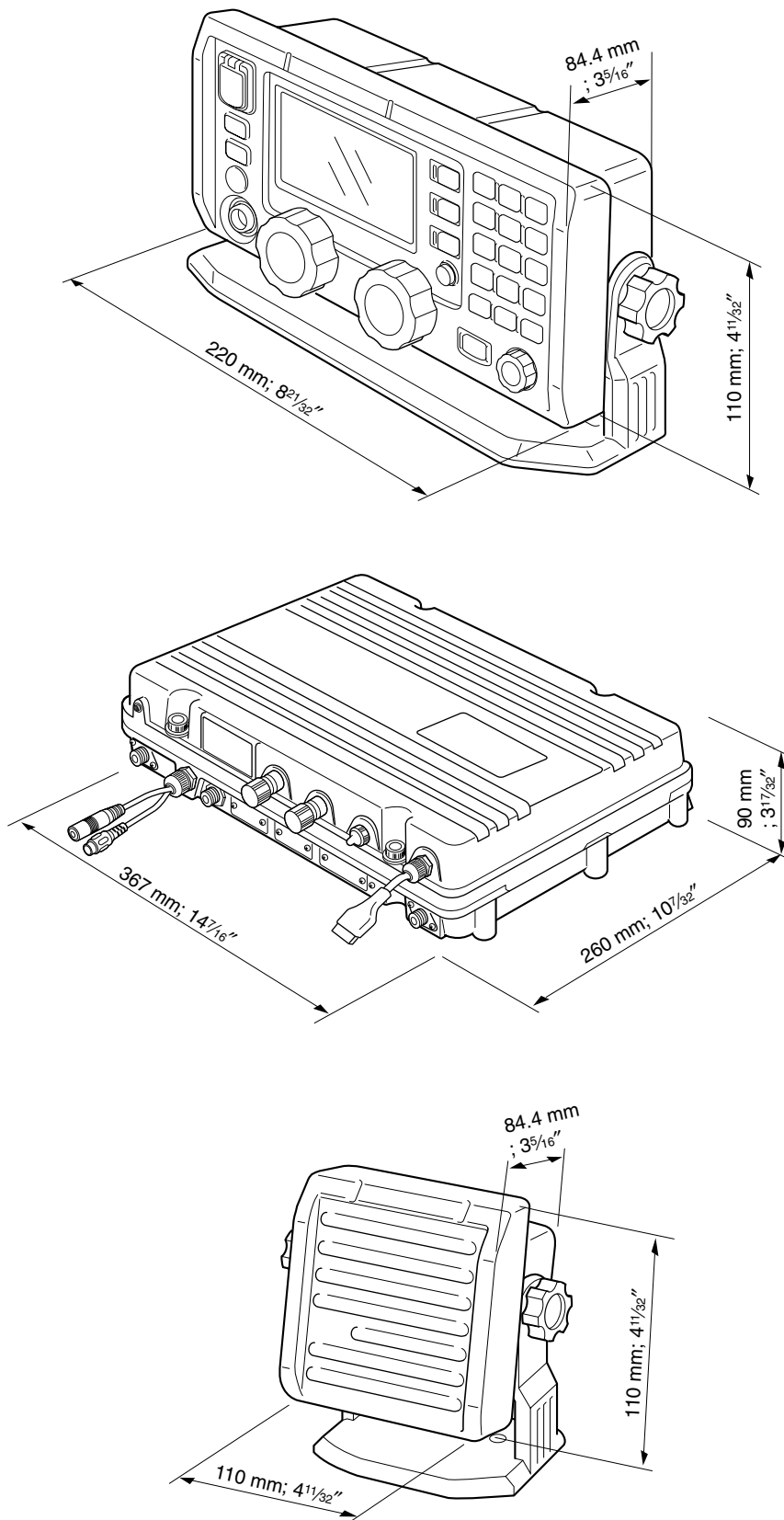

■ Fuse replacement

The transceiver has 2 fuses to protect internal circuitry. If the transceiver stops functioning, check the fuses below.

- DC-DC converter unit FGB 5 A
- PA unit FGB 5 A

CAUTION: DISCONNECT the DC power cable from the transceiver when changing a fuse.

◇ Fuse replacement

- ① Unscrew 4 cap-bolts from the top case.
 - Use 6 mm (1/4") allen wrench.

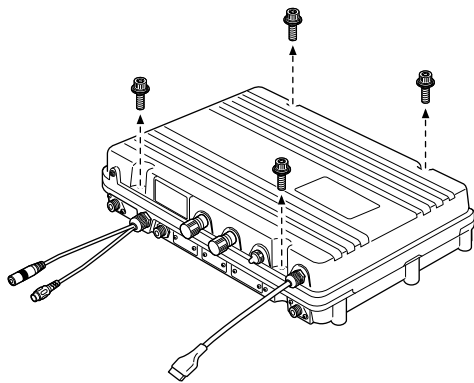

- ② Open the transceiver's main unit, then disconnect 1 flat and 2 coaxial cables as shown below.

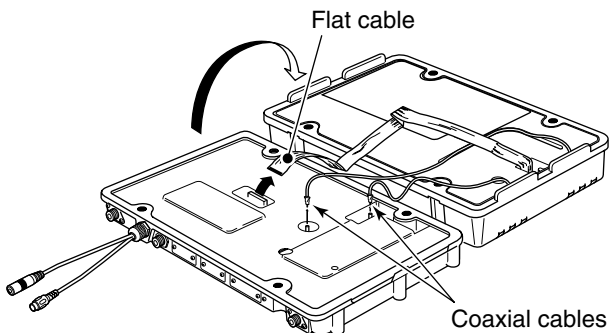

- ③ Unscrew 32 screws from the shield covers, then open the covers.

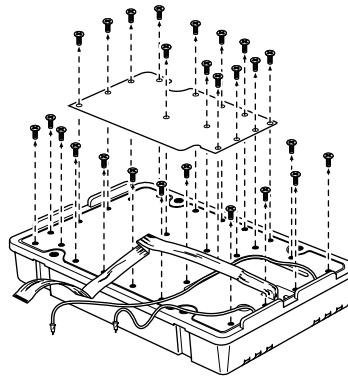

- ④ Replace the circuitry fuse as shown in the diagram below.
 - Use the supplied FGB 5 A fuse.

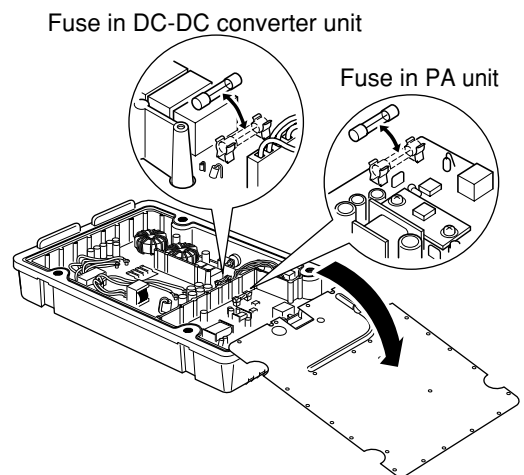

- ⑤ Attach the shield covers, flat cable, coaxial cables and top case to their original position.

■ Connector information

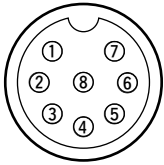
MICROPHONE	Pin	Pin name	Description	Specification
 <p>Front panel view</p>	1	MIC+	Audio input from the mic element.	Input impedance : 2.4kΩ
	2	NC	No connection.	
	3	AF1	AF output controlled with [VOL].	
	4	AF2	Ground for AF1.	
	5	PTT	PTT switch input.	When grounded, transmits.
	6	GND	Connected to the ground.	
	7	MIC-	Coaxial ground for MIC+.	
	8	AF-	Coaxial ground for AF1 and AF2.	

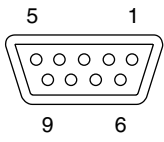
AF/MOD	Pin	Pin name	Description	Specification
 <p>Front panel view</p>	1	MOD+	Modulation input from an external terminal unit.	Input impedance : 600 Ω Input level : Approx. 0.77 V rms.
	2	MOD-	Coaxial ground for MOD+.	
	3	AF+	AF detector output for an external terminal unit.	Output impedance: 600 Ω Output level : 0.25–2.5 V rms
	4	AF-	Coaxial ground for AF+.	
	5	SEND	Transmits when grounded.	Output level : –0.5 to 0.8 V Input level : Less than 20 mA
	6	CWK	FSK keying input/output.	When grounded, transmits.
	7	13.6V	13.6 V DC output during power ON.	
	8	ALC	ALC voltage input.	
	9	GND	Ground for digital equipment.	

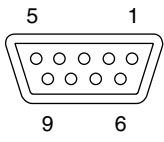
REMOTE	Pin	Pin name	Description
 <p>Front panel view</p>	1	DCD	Input terminal for carrier detection. ("RS-232C" selection for REMOTE IF. (p. 46))
		NMEA-OUT (-)	Ground for NMEA-OUT (+). ("NMEA" selection for REMOTE IF. (p. 46))
	2	RXD	Input terminal for receive data. ("RS-232C" selection for REMOTE IF. (p. 46))
		NMEA-OUT (+)	NMEA0183 ver. 3.01 data output. ("NMEA" selection for REMOTE IF. (p. 46))
	3	TXD	Outputs transmit data. ("RS-232C" selection for REMOTE IF. (p. 46))
		NMEA-IN (+)	NMEA0183 ver. 3.01 data input. ("NMEA" selection for REMOTE IF. (p. 46))
	4	DTR	Outputs data terminal ready signal. ("RS-232C" selection for REMOTE IF. (p. 46))
		NMEA-IN (-)	Ground for NMEA-IN (+). ("NMEA" selection for REMOTE IF. (p. 46))
	5	GND	Connected to the ground.
	6	DSR	Input terminal for data-set-ready signal.
	7	RTS	Outputs request-to-send data.
8	CTS	Input terminal for clear-to-send data.	
9	NC	No connection.	

■ Connector information (continued)

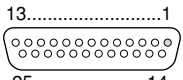
REMOTE	Pin	Pin name	Description
 <p>13.....1 25.....14 Front panel view</p>	1	STROBE	Outputs a strobe pulse after data output.
	2–9	DATA1–8	Outputs 8-bit parallel data.
	10	ACKNLG	Input port for the connected printer. “Low” pulse signal is applied from the printer during the printer accepts data input.
	11	BUSY	Input port for the connected printer. “High” level signal is applied from the printer during the printer cannot accept data input, such as when off line.
	12–14	NC	No connection.
	15	ERROR	Input port for the connected printer. The printer output becomes “Low” when an printer error, such as no paper, occurs.
	16, 17	NC	No connection.
	18–25	GND	Ground terminals.

Frequency selection

Using the channel selector

- Select a channel which is programmed near the frequency you want to receive.
- Push [RX CLAR] to select the frequency selection mode.
 - “▶” appears in the display.

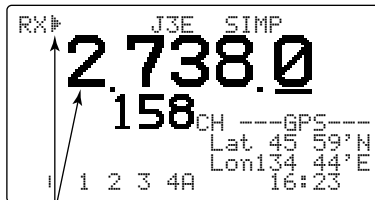

“▶” and frequency show that the frequency can be changed.

- Rotate [GRP] to select the digit for tuning.
 - Under-bar shows the selected digit.

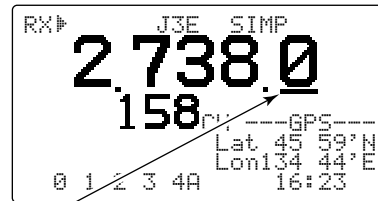

The under-bar is moved by rotating [GRP].

- Rotate [CH] to tune the frequency.
 - Pushing [▲]/[▼] on the microphone also tunes the frequency.
- Repeat steps ③ and ④ to complete the frequency selection.
- To return to the previous frequency, push [RX CLAR].
 - “▶” disappears.

Using the keypad

CAUTION: A frequency can be programmed into a user or e-mail channel by pushing and holding [ENT] for 1 sec. after entering a frequency. An ITU simplex frequency can only be programmed on a temporary basis. Keypad entry should be used only on spare (or blank) channels.

- Rotate [GRP] and [CH], or enter a 1 to 4 digit number via the keypad, then push [ENT] to select the memory channel to be used for general coverage use.

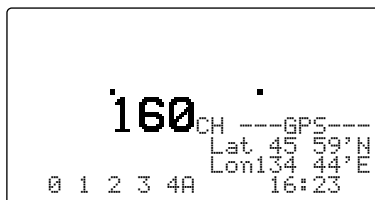

When a blank channel is selected, operating frequency, mode and channel name do not appear.

- Push [RX CLAR] to select the frequency selection mode.
 - “▶” appears in the display.
- Enter 4 to 6 digits of the desired frequency via the keypad.
- Push [ENT] momentarily to input the frequency.
 - DO NOT hold** [ENT] for more than 1 sec., otherwise the frequency will be programmed into the channel.

[EXAMPLE]: Setting 12.3450 MHz

Select blank channel.

Push [RX CLAR]



[1 NB]



[2 SQL], [3 SCAN],
[4 SP.], [5 AGC]



[0 DIM]

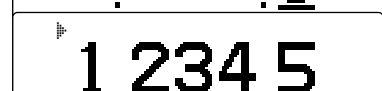

[ENT]

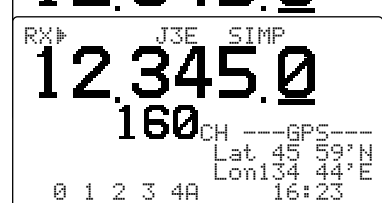
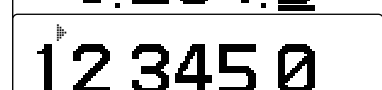

•The set frequency can be cleared when [RX CLAR] is pushed while setting.

■ Programming a frequency

◆ Receive frequency

- ① Select the desired channel to be programmed.
 - Channel 1 to 160 (maximum) are programmable.
- ② Push [RX CLR] to select the frequency selection mode.

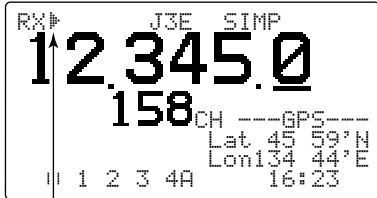

“▶” indicator appears.

- ③ Enter 4 to 6 digits of the desired frequency via the keypad.
 - Or rotate [GRP] and [CH] to change the frequency.
 - Pushing [▲]/[▼] on the microphone also tunes the frequency.

- ④ Push [MODE SET] several times to select the desired operating mode (type of emission).

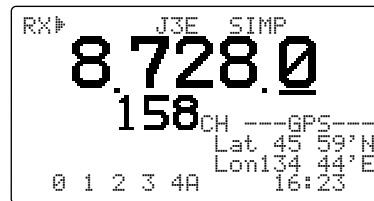

- ⑤ Push [ENT] for 1 sec. to program the user channel.
 - 3 beeps sound and “▶” disappears.

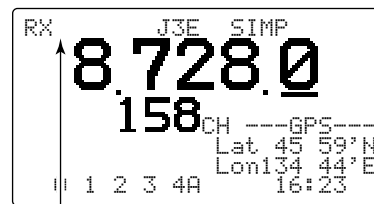

“▶” indicator disappears when programming is completed.

◆ Transmit frequency

- ① Select the desired channel to be programmed.
- ② Push [TX TXF].

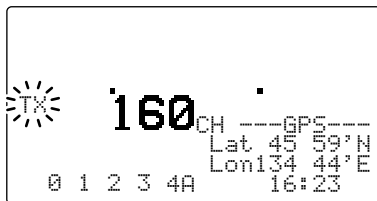

“TX” indicator blinks.

- ③ Enter the desired 5 or 6 digit frequency via the keypad.
 - [GRP] and [CH], as well as [▲]/[▼] on the microphone cannot be used.

- ④ Push [ENT] for 1 sec. to program the user channel.
 - 3 beeps sound.

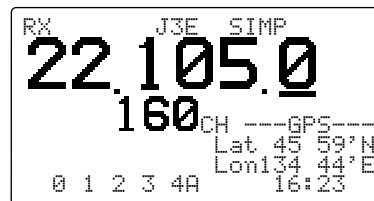

“TX” indicator disappears.

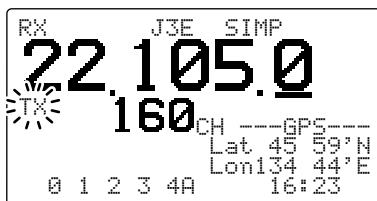

•General

- Frequency coverage : (Unit: MHz)

Receive	0.5–29.9999	
Transmit	1.6–2.9999	4.0–4.9999
	6.0–6.9999	8.0–8.9999
	12.0–13.9999	16.0–17.9999
	18.0–19.9999	22.0–22.9999
	25.0–27.5000	
- DSC channels : 2,187.5 kHz, 4,207.5 kHz,
6,312.0 kHz, 8,414.5 kHz,
12,577.0 kHz, 16,804.5 kHz
- Type of emission :

Transceiver	J3E (USB/LSB*), H3E,* J2B (AFSK), F1B (FSK), A1A* (CW)
DSC receiver	F1B

*Receive only
- No. of memory Ch. : 1205 channels (max.)
160 user programmable, 249 ITU
SSB duplex, 124 ITU SSB
simplex, 662 ITU FSK duplex and
10 Semi/Auto channels
- Antenna connector : SO-239×2 (50 Ω)
- Usable temp. range : –15°C to +55°C
- Frequency stability : ±10 Hz
(Approx. 5 min. after battery connection.)
- Power supply :

12 V DC version	10.8–15.6 V DC (floating ground)
24 V DC version	21.6–31.2 V DC (floating ground)
- Current drain :

12 V DC version	
Transmit	at max. power 60 A
Receive	at max. audio Less than 6.0 A
24 V DC version	
Transmit	at max. power 30 A
Receive	at max. audio Less than 3.0 A
- Dimensions (projections not incl.):

Main unit	367(W)×95(H)×260(D) mm
Controller (RC-25E)	220(W)×110(H)×84.4(D) mm
Speaker (SP-24E)	110(W)×110(H)×84.4(D) mm
- Weight (approx.) :

Main unit	8.5 kg
Controller (RC-25E)	570 g
Speaker (SP-24E)	370 g
- CONTROLLER connector : 8-pin connector
- GPS connector : RCA (NMEA0183 ver. 3.01)
- REMOTE connector : D-sub 9-pin (RS-232C/NMEA)
- AF/MOD connector : D-sub 9-pin
- PRINTER connector : D-sub 25-pin

•Transmitter

- Output power :

1.6–3.9999 MHz	85 W p-p
4.0–27.5000 MHz	125 W p-p
- Spurious emission : 43 dB below peak output power
- Carrier suppression : 40 dB below peak output power
- Unwanted sideband suppression : 55 dB below peak output power
(w/1 kHz AF input; at max power)
- Mic. connector : 8-pin connector (2.4 kΩ)

•Receiver

- Sensitivity :

Transceiver	
J3E, A1A (20 dB SINAD)	30 dBμV emf (0.5–1.5999 MHz) 13 dBμV emf (1.6–1.7999 MHz) 8 dBμV emf (1.8–29.9999 MHz)
J2B, F1B (20 dB SINAD)	13 dBμV emf (1.6–1.7999 MHz) 8 dBμV emf (1.8–29.9999 MHz)
H3E (20 dB SINAD)	44 dBμV emf (0.5–1.5999 MHz) 30 dBμV emf (1.6–1.7999 MHz) 24 dBμV emf (1.8–3.9999 MHz)
DSC receiver	0 dBμV emf (all channels)
- Spurious response rejection ratio:

Transceiver	
	More than 70 dB (0.5–29.9999 MHz)
DSC receiver	
	More than 60 dB (1st image) More than 50 dB (except 1st image)
- AF output power : More than 4.0 W at 10% distortion
(at 13.2 V DC) with a 4 Ω load
- CLARITY variable range : ±150 Hz
- Headphone connector : 3-conductor 3.5 (d) mm (1/8")
- SP connector : 2-conductor 3.5 (d) mm (1/8")/4 Ω

All stated specifications are typical and subject to change without notice or obligation.

15 OPTIONS

AT-141 HF AUTOMATIC ANTENNA TUNER



Matches the transceiver to a long wire antenna with a minimum of insertion loss.

RC-25E REMOTE CONTROLLER

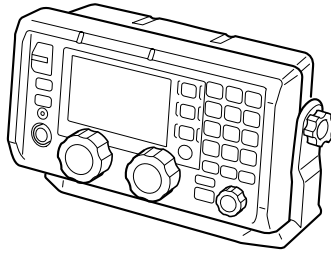

Same as that supplied remote with the transceiver. Mounting bracket, MB-81, is supplied with the controller.

SP-24E EXTERNAL SPEAKER



Same as that supplied with the transceiver. Mounting bracket, MB-82 is supplied with the speaker.
Max. AF input/impedance: 5 W/4 Ω

HS-98 HANDSET

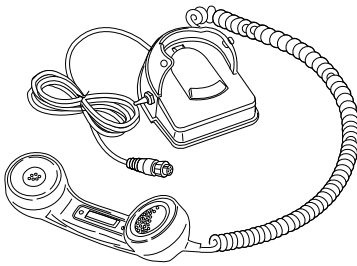

Same as that supplied with the IC-M801E.

HM-135 HAND MICROPHONE



Equipped with channel up/down and user-programmable keys.

MB-75 FLUSH MOUNT KIT



For mounting the remote controller (RC-25E) or the SP-24E to a panel.

MB-108 MOUNTING BRACKET



One-touch bracket. Transceiver main unit easily attached or removed.

OPC-1465 SHIELDED CONTROL CABLE

Shielded control cable protects the transceiver from RF feedback and extends the separation between AT-141 and transceiver up to 10 m .

OPC-1466 SEPARATION CABLE

Same as that supplied with the transceiver. Cable length: 5 m

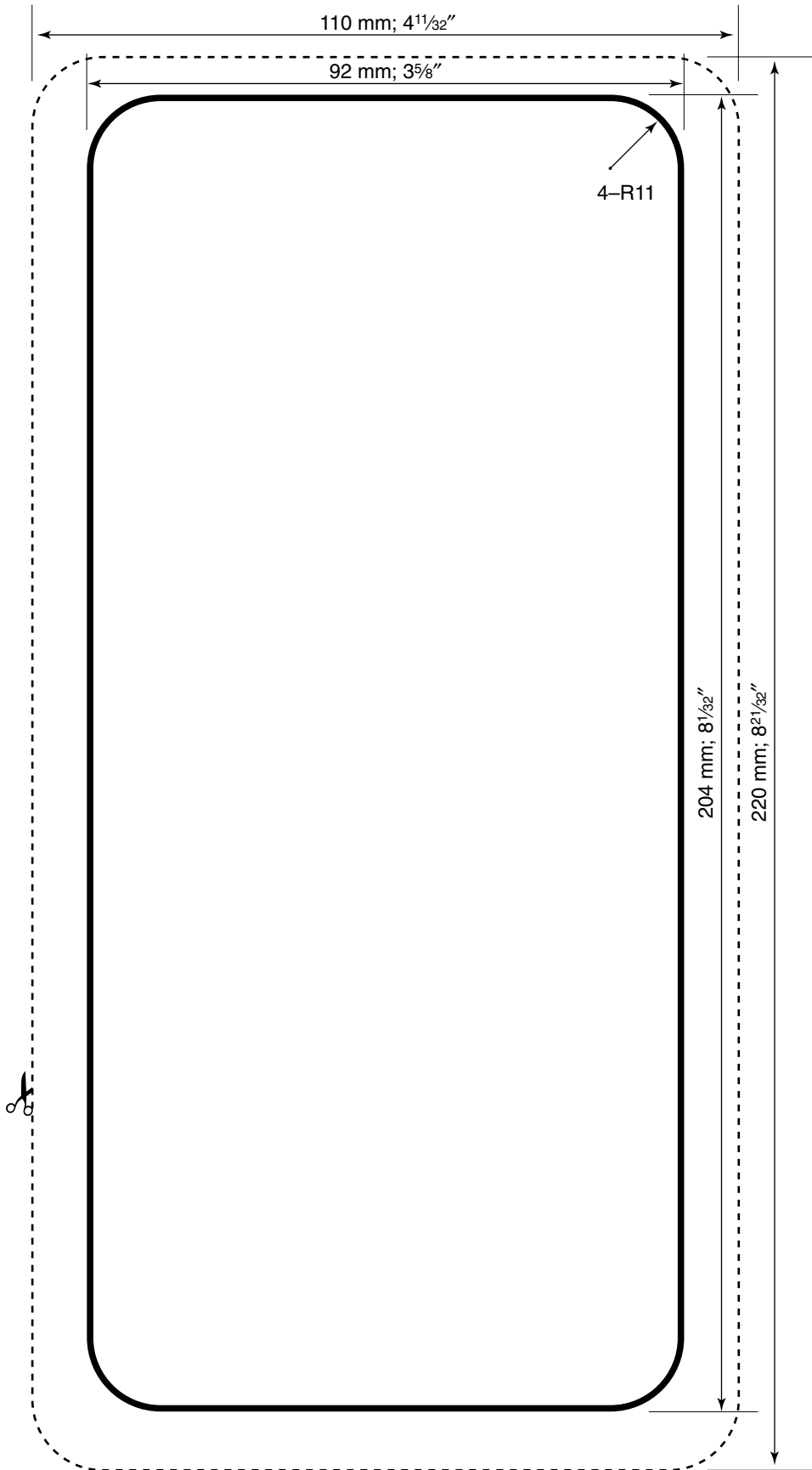

■ Remote controller (RC-25E)

<Cut here>

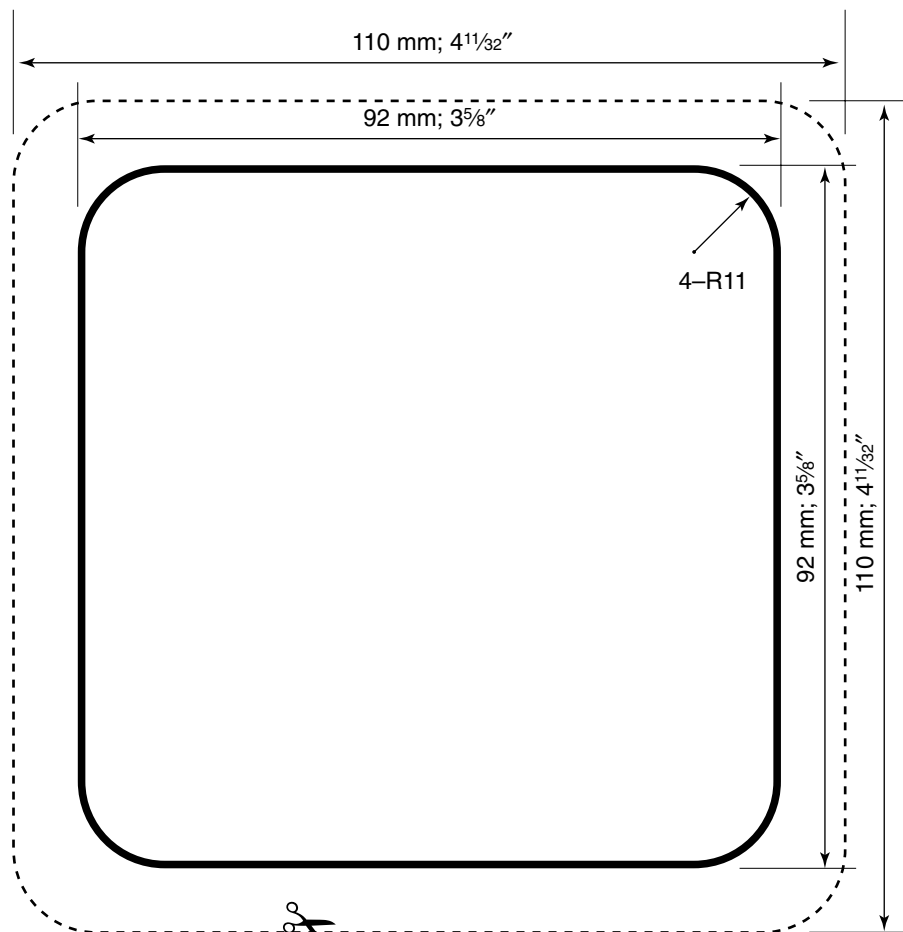

■ Speaker (SP-24E)



 <p>We Icom Inc. Japan 1-1-32, Kamiminami, Hirano-ku Osaka 547-0003, Japan</p> <p>Declare on our sole responsibility that this equipment complies with the essential requirements of the Radio and Telecommunications Terminal Equipment Directive, 1999/5/EC, and that any applicable Essential Test Suite measurements have been performed.</p> <p>Kind of equipment: MF/HF MARINE TRANSCEIVER +HF AUTOMATIC ANTENNA TUNER</p> <hr/> <p>Type-designation: IC-M801E + AT-141</p> <hr/> <p>Version (where applicable):</p> <p>This compliances is based on conformity with the following harmonised standards, specifications or documents:</p> <table style="width: 100%; border-collapse: collapse;"> <tr> <td style="width: 50%;">i) EN 300 373-2</td> <td style="width: 50%;">V1.1.1 (2004-01)</td> </tr> <tr> <td>ii) EN 300 373-3</td> <td>V1.1.1 (2004-01)</td> </tr> <tr> <td>iii) EN 60945</td> <td>2002</td> </tr> <tr> <td>iv) EN 60950-1 (2001) + A11 (2004)</td> <td></td> </tr> <tr> <td>v) _____</td> <td></td> </tr> </table>	i) EN 300 373-2	V1.1.1 (2004-01)	ii) EN 300 373-3	V1.1.1 (2004-01)	iii) EN 60945	2002	iv) EN 60950-1 (2001) + A11 (2004)		v) _____		<p style="text-align: center;">DECLARATION OF CONFORMITY</p> <div style="text-align: center; font-size: 24pt; font-weight: bold;">C €0560 !</div> <p>Düsseldorf 21th Nov. 2005 Place and date of issue</p> <p>Icom (Europe) GmbH Himmelgeister straÙe 100 D-40225 Düsseldorf Authorized representative name</p> <p>H. Ikegami General Manager</p> <div style="text-align: center;">  _____ Signature </div> <p style="text-align: right; font-weight: bold; font-size: 14pt;">Icom Inc.</p>
i) EN 300 373-2	V1.1.1 (2004-01)										
ii) EN 300 373-3	V1.1.1 (2004-01)										
iii) EN 60945	2002										
iv) EN 60950-1 (2001) + A11 (2004)											
v) _____											

C E CE Versions of the IC-M801E which display the “CE” symbol on the serial number seal, comply with the essential requirements of the European Radio and Telecommunication Terminal Directive 1999/5/EC.



This warning symbol indicates that this equipment operates in non-harmonised frequency bands and/or may be subject to licensing conditions in the country of use. Be sure to check that you have the correct version of this radio or the correct programming of this radio, to comply with national licensing requirement.

Count on us!

<Intended Country of Use>

- GER FRA ESP SWE
 AUT NED POR DEN
 GBR BEL ITA FIN
 IRL LUX GRE SUI
 NOR

Icom America Inc.

<Corporate Headquarters>
2380 116th Avenue N.E., Bellevue, WA 98004, U.S.A.
Phone: +1 (425) 454-8155 Fax: +1 (425) 454-1509
URL: <http://www.icomamerica.com>
E-mail: sales@icomamerica.com
<Customer service>
Phone: (425) 454-7619

Icom (Europe) GmbH

Communication Equipment
Himmelgeister Str. 100,
D-40255 Düsseldorf, Germany
Phone: +49 0211 346047 Fax: +49 0211 333639
URL: <http://www.icomeurope.com>
E-mail: info@icomeurope.com

Icom Canada

Glenwood Centre #150-6165 Highway 17, Delta,
B.C., V4K 5B8, Canada
Phone: +1 (604) 952-4266 Fax: +1 (604) 952-0090
URL: <http://www.icomcanada.com>
E-mail: info@icomcanada.com

Icom Spain S.L.

Ctra. Rubi, No. 88 "Edificio Can Castanyer"
08190, Sant Cugat del Valles, Barcelona, Spain
Phone: +34 (93) 590 26 70 Fax: +34 (93) 589 04 46
URL: <http://www.icomspain.com>
E-mail: icom@icomspain.com

Icom (Australia) Pty. Ltd.

A.B.N. 88 006 092 575
Unit 1/103, Garden Road, Clayton, Victoria, 3168,
Australia
Phone: +61 (03) 9549 7500 Fax: +61 (03) 9549 7505
URL: <http://www.icom.net.au>
E-mail: sales@icom.net.au

Icom (UK) Ltd.

Unit 9, Sea St., Heme Bay, Kent, CT6 8LD, U.K.
Phone: +44 01227 741741 Fax: +44 01227 741742
URL: <http://www.icomuk.co.uk>
E-mail: info@icomuk.co.uk

Icom New Zealand

146A Harris Road, East Tamaki, Auckland, New Zealand
Phone: +64 09 274 4062 Fax: +64 09 274 4708
URL: <http://www.icom.co.nz>
E-mail: inquiries@icom.co.nz

Icom France S.a

Zac de la Plaine, 1, Rue Brindejonc des Moulinais
BP 5804, 31505 Toulouse Cedex, France
Phone: +33 (5) 61 36 03 03 Fax: +33 (5) 61 36 03 00
URL: <http://www.icom-france.com>
E-mail: icom@icom-france.com

Asia Icom Inc.

6F No. 68, Sec. 1 Cheng-Teh Road, Taipei, Taiwan R.O.C.
Phone: +886 (02) 2559 1899 Fax: +886 (02) 2559 1874
URL: <http://www.asia-icom.com>
E-mail: sales@asia-icom.com

Icom Polska

Sopot, 3 Maja 54 Poland
Phone: +48 (58) 550 7135 Fax: +48 (58) 551 0484
E-mail: icompolska@icompolska.com.pl

Beijing Icom Ltd.

Room C01, 10th Floor, Long Silver Mansion, No. 88
Yong Ding Road, Haidian District, Beijing, 100039,
China
Phone: +86 (010) 5889 4250 Fax: +86 (010) 5889 4250
URL: <http://www.bjicom.com>
E-mail: bjicom@bjicom.com