



Function Reference

For

***TK-2180/ 3180/
7180/ 8180***

<i>Version:</i>	<i>1.11</i>
<i>Last Updated:</i>	<i>Aug, 2004</i>
<i>Language:</i>	<i>English</i>
<i>Type:</i>	<i>K</i>

	1.
	3.4.2 Battery Status/Warning 20
	3.5 Sub Display..... 21
	3.6 Main Display 21
	3.6.1 Zone Name..... 21
	3.6.2 Zone Name Text Length..... 22
	3.6.3 Channel Name 22
	3.6.4 GID Name 22
	3.6.5 Display Character..... 22
	3.6.6 Power-on Text..... 23
	3.6.7 Volume Indicator 23
1 BASIC FUNCTION 1	
1.1 Functions and Panel Layout 1	
1.1.1 TK-2180/ 3180..... 1	
1.1.2 TK-7180/ 8180..... 1	
1.2 Zone Description..... 4	
1.3 Transmit/Receive Frequency 4	
1.4 Transmit Output Power 4	
1.5 Channel Spacing..... 5	
1.6 Squelch Level 5	
1.7 Compander 6	
1.8 Beat Shift 7	
1.9 Key Lock 7	
1.10 Keypad Operation 7	
1.11 Call Key..... 8	
1.12 Mic Sense Control..... 8	
1.13 Battery Saver 9	
1.14 Power Switch Status Memory 9	
1.15 Mic PTT..... 9	
2 BASIC OPERATION..... 11	
2.1 Turning the Transceiver ON/OFF 11	
2.1.1 Turning the Transceiver ON 11	
2.1.2 Turning the Transceiver OFF 12	
2.2 Adjusting the Volume 12	
2.3 Using Function Keys 12	
2.4 Changing the Zone 12	
2.5 Changing the CH/GID 13	
2.6 Channel Entry 13	
2.7 Home CH/GID 14	
2.8 Direct CH/GID 15	
2.9 Receive 16	
2.9.1 Conventional Group 16	
2.9.2 Trunking System 6	
2.10 Transmit..... 17	
2.10.1 Conventional Group 17	
2.10.2 Trunking System 17	
2.11 Transmitting with Talk Around 17	
2.11.1 Conventional Group 17	
2.11.2 Trunking System 17	
3 DISPLAY..... 18	
3.1 BUSY LED 18	
3.2 TX LED 18	
3.3 LCD Display 18	
3.3.1 Backlight..... 18	
3.3.2 LCD Brightness1 9	
3.4 Icons 19	
3.4.1 Signal Strength Indicator 20	
4 SOUND 24	
4.1 Tone Pattern 24	
4.1.1 Power-on Tone..... 24	
4.1.2 Control Tone..... 24	
4.1.3 Warning Tone..... 25	
4.1.4 Locator Tone 25	
4.1.5 Sidetone 25	
4.2 Minimum Volume 25	
4.3 Maximum Volume 26	
4.4 Tone Volume Offset 26	
4.5 Tone Volume..... 26	
4.6 Selectable Tone Level 27	
4.7 Alert Tone Pattern..... 27	
4.8 PTT Release Tone..... 27	
4.9 PTT Proceed Tone..... 28	
4.10 Proceed Tone Delay Time 28	
4.11 Speaker Attenuation 28	
4.12 Public Address 29	
5 PASSWORD FUNCTION 30	
5.1 Transceiver Password 30	
5.2 Read Authorization Password..... 31	
5.3 Overwrite Password..... 32	
6 EMBEDDED MESSAGE FUNCTION..... 33	
6.1 Embedded Message 33	
6.2 Embedded Message with Password..... 33	
7 COMMUNICATION PORT..... 34	
7.1 COM Port..... 34	
8 IGNITION SENSE..... 36	
8.1 Using the Ignition Sense Terminal 36	
8.1.1 Turning the Transceiver ON/OFF with the Igni- tion Sense Function 36	
8.1.2 Turning the Transceiver ON/OFF with the Igni- tion Sense Function and the Power Switch.. 36	
8.2 Timed Power-off..... 36	

	1.
9 HORN ALERT.....	37
9.1 Switching the Horn Alert ON/OFF	37
9.2 Horn Alert Operation using Option Signaling and LTR ID.....	37
9.2.1 Conventional Group	37
9.2.2 Trunking System	38
9.3 Horn Alert Operation During FleetSync Call ..	38
9.4 Configuring Horn Alert	38
9.4.1 Horn Alert Logic Signal.....	38
9.4.2 Off-hook Horn Alert	39
9.4.3 Horn Alert Mode	40
10 KEY ASSIGNMENT	41
10.1 Available Functions.....	41
10.2 Assigning Functions to the PF Keys	41
11 TIME-OUT TIMER.....	44
11.1 Conventional Group	44
11.1.1 Time-out Timer	44
11.1.2 TOT Pre-alert	44
11.1.3 TOT Rekey Time	44
11.1.4 TOT Reset Time.....	44
11.2 Trunking System	45
11.2.1 Time-out Timer (Dispatch).....	45
11.2.2 Time-out Timer (Telephone).....	45
12 BUSY CHANNEL LOCKOUT	46
12.1 Busy Channel Lockout	46
12.2 BCL Override	46
13 TALK AROUND	47
13.1 Conventional Group	47
13.2 Trunking System	47
13.2.1 TA Busy Channel Lockout.....	48
13.2.2 TA Key.....	48
14 PTT ID	49
14.1 PTT ID Type.....	49
14.1.1 Beginning of Transmit	49
14.1.2 End of Transmit.....	49
14.2 PTT ID (CH/GID Information).....	49
14.3 Restricted ID in TA.....	50
15 TRANSPOND	51
15.1 Transpond Using the Optional Signaling	51
15.2 Transpond Using the LTR ID	51
15.3 Conventional Group	51
15.3.1 Clear to Transpond.....	51
15.4 Trunking System	51
15.4.1 Transpond Delay Time.....	51
16 CONVENTIONAL GROUP	52
16.1 Zone.....	52
16.1.1 Zone Name.....	52
16.1.2 Data Zone-CH/GID	52
16.1.3 Home Channel	52
16.1.4 Home Channel Operator Selectable	52
16.1.5 Optional Signaling Decode Condition.....	52
16.1.6 Audio Control.....	53
16.1.7 Time-out Timer (TOT)	53
16.1.8 TOT Pre-alert	53
16.1.9 TOT Rekey Time	53
16.1.10 TOT Reset Time.....	53
16.1.11 BCL Override.....	53
16.1.12 Zone Add.....	53
16.1.13 Scan List.....	53
16.2 Channel.....	54
16.2.1 Receive Frequency	54
16.2.2 Transmit Frequency	54
16.2.3 QT/DQT Decode	54
16.2.4 QT/DQT Encode.....	54
16.2.5 Channel Name	54
16.2.6 Transmit Power	54
16.2.7 Wide/Narrow.....	55
16.2.8 Optional Signaling	55
16.2.9 Busy Channel Lockout	55
16.2.10 PTT ID	55
16.2.11 Beat Shift.....	55
16.2.12 Scan Add.....	55
16.2.13 Compander.....	55
16.2.14 Data.....	55
16.2.15 Voice Scrambler	56
16.2.16 Scrambler Code	56
17 LTR TRUNKING	57
17.1 Zone.....	57
17.1.1 Zone Name.....	57
17.1.2 Scan Weight	57
17.1.3 Wide/Narrow.....	58
17.1.4 Data Zone-CH/GID	58
17.1.5 Data Delay Time.....	58
17.1.6 Home GID	58
17.1.7 Home GID Operator Selectable	58
17.1.8 Time-out Timer (Dispatch).....	58
17.1.9 Time-out Timer (Telephone).....	58
17.1.10 Audio Control.....	59
17.1.11 Encode Data Type.....	59
17.1.12 Zone Add.....	59
17.1.13 Scan List.....	59
17.1.14 Auto Telephone Search.....	59
17.1.15 TA Busy Channel Lockout.....	59
17.1.16 TA Key.....	59
17.1.17 Fix ID.....	60
17.1.18 Telephone (Block IDs).....	60
17.1.19 TX Inhibit (Block IDs).....	60

		1.
17.1.20	Decode ID (Block IDs).....	60
17.2	Group ID	61
17.2.1	Encode/ Decode ID	61
17.2.2	GID Name	61
17.2.3	Transmit Power	61
17.2.4	Optional Signaling	61
17.2.5	PTT ID	61
17.2.6	Call Indicator	61
17.2.7	Horn Alert	62
17.2.8	Scan Add.....	62
17.2.9	Transpond	62
17.2.10	Talk Around.....	62
17.2.11	Compander.....	62
17.2.12	Data.....	62
17.2.13	Scrambler.....	62
17.2.14	Scrambler Code	63
17.3	Home Repeater.....	63
17.3.1	Area Code	63
17.3.2	Home Repeater.....	63
17.3.3	Repeater Information Table.....	63
17.4	Telephone Interconnect	64
17.4.1	Connecting to the Phone Line.....	64
17.4.2	Auto Telephone Search.....	64
17.4.3	Free System Ringback	65
17.5	System Search.....	65
17.5.1	System Search for Voice Channels.....	66
17.5.2	System Search for Data Channels.....	66
17.6	Clear to Talk.....	66
17.7	ARQ Mode	67
17.7.1	Transceiver Operation When Using the ARQ Function in the External Modem.....	67
17.7.2	Transceiver Operation When Using the ARQ Function with FleetSync	67
18	SIGNALING	68
18.1	QT/DQT Decode/Encode.....	68
18.1.1	With STE (Squelch Tail Eliminator).....	68
18.2	Optional Signaling.....	68
18.3	Signaling (Audio Control).....	69
18.3.1	Conventional Group	69
18.3.2	Trunking System	69
18.4	Signaling (Decode)	69
18.4.1	Conventional Group	69
18.4.2	Trunking System	70
18.5	Off-hook Decode	70
18.6	Monitor	70
18.6.1	Operations during Scan in Conventional Group	71
18.6.2	Operations during Scan in Trunking System.....	71
18.7	Squelch	71
18.7.1	Operations during Scan in Conventional Group.....	73
18.7.2	Operations during Scan in Trunking system ..	73
19	OST.....	74
19.1	OST Status Memory	74
19.2	Tone Off.....	74
19.3	Direct OST	74
19.4	OST Table.....	76
19.5	Standard QT	76
20	DTMF	77
20.1	Transmitting DTMF Tones	77
20.1.1	Manual Dialing.....	77
20.1.2	Store & Send	77
20.1.3	Keypad Auto PTT	79
20.1.4	Autodial List Selection	80
20.1.5	Redial	80
20.1.6	Connect ID (BOT).....	81
20.1.7	Disconnect ID (EOT)	81
20.2	Encode.....	82
20.2.1	DTMF Speed	82
20.2.2	First Digit Delay Time	82
20.2.3	First Digit Time	83
20.2.4	* and # Digit Time.....	83
20.2.5	DTMF Hold Time	83
20.2.6	D Code Assignment	83
20.2.7	Sidetone	83
20.2.8	Manual Dialing.....	83
20.2.9	Store & Send	84
20.2.10	Auto Telephone	84
20.3	Decode.....	84
20.3.1	Code.....	84
20.3.2	Transpond/ Alert Tone	84
20.3.3	Stun	85
20.3.4	Auto Reset Timer	85
20.3.5	Clear to Transpond.....	86
20.3.6	Selective Call Alert LED	86
20.4	Autodial.....	86
20.4.1	Autodial List.....	86
20.4.2	Autodial Programming.....	86
21	2-TONE.....	89
21.1	Transmitting 2-tone	89
21.2	Encode.....	89
21.2.1	Duration of 1st Tone.....	90
21.2.2	Duration of 2nd Tone.....	90
21.2.3	Duration of Single Tone.....	90
21.2.4	Gap Time.....	90
21.2.5	First Tone Delay Time	90
21.2.6	Sidetone	90
21.2.7	2-tone Encode Memory List	90
21.3	Decode.....	91
21.3.1	Decoder 1 - 4.....	91
21.3.2	A Tone/ B Tone/ C Tone/ D Tone.....	92
21.3.3	Auto Reset Timer	92
21.3.4	Clear to Transpond.....	92
21.3.5	Selective Call Alert LED	92
22	FLEETSYNC.....	94
22.1	PTT ID Function.....	94

22.1.1	Caller ID Display.....	94	22.9.13	ACK Delay Time.....	121
22.1.2	PTT ID Sidetone.....	94	22.9.14	Transmit Delay Time (Receive Capture)	121
22.2	Selective Call Function	95	22.9.15	Data Transmit Modulation Delay Time ..	122
22.2.1	Making a Selective Call.....	95	22.9.16	Random Access (Contention)	122
22.2.2	Receiving a Selective Call.....	97	22.9.17	Unit ID Serial Output	122
22.2.3	ID List.....	99	22.9.18	Selective Call Alert LED	122
22.3	Status Message Function	99	22.9.19	Message Display Type.....	122
22.3.1	Sending the Status Message	99	22.9.20	Alert Tone (Individual Call).....	123
22.3.2	Receiving the Status Message.....	103	22.9.21	Alert Tone (Other Selective Calls).....	123
22.3.3	Reserved Status of the Status Message	104	22.9.22	Alert Tone (Paging Call).....	123
22.3.4	Status Message Stack.....	105	22.9.23	Alert Tone (Status/Short Message Call)	123
22.3.5	Status Message on Data Zone-CH/GID	105	22.9.24	Alert Tone (Emergency Response).....	123
22.3.6	Status Message Serial Output.....	105	22.9.25	PC Interface Protocol	124
22.3.7	AUX Input Status Message	105			
22.3.8	AUX Output Status Message	106			
22.3.9	Power-on Status Message	106	23 SCAN.....	125	
22.3.10	Power-off Status Message	106	23.1	Scan Operation.....	125
22.3.11	Status List.....	106	23.1.1	Conditions to Activate Scan	125
22.3.12	Target Fleet/ID (Status Message)	106	23.1.2	Conditions to Resume Scan	125
22.3.13	Status 80 - 99 (Special).....	107	23.1.3	Operations when Scan cannot be Resumed.....	125
22.3.14	Emergency Status Response.....	107	23.1.4	Manually Changing the Zone-CH/GID during Scan.....	126
22.4	Short Message Function.....	107	23.1.5	Operations when Manually Changing the Zone- CH/GID while Scan Pauses to Receive	126
22.4.1	Sending the Short Message.....	107	23.1.6	Operations during Scan in Conventional Group	126
22.4.2	Receiving the Short Message	108	23.1.7	Operations while Making Scan in Trunking System	127
22.4.3	Short Message Stack	109	23.2	Single Scan.....	127
22.4.4	Short Message on Data Zone-CH/GID..	109	23.3	Multi Scan	128
22.4.5	Short Message Serial Output	109	23.4	List Scan	128
22.5	Long Message Function.....	110	23.5	Priority Scan.....	129
22.5.1	Sending the Long Message.....	110	23.6	Group Scan.....	130
22.5.2	Receiving the Long Message	110	23.7	Configuring Scan	130
22.5.3	Long Message On Data Zone-CH/GID .	111	23.7.1	Scan Del/Add	130
22.6	GPS Function.....	111	23.7.2	Scan List.....	131
22.6.1	Base Fleet/ID.....	112	23.7.3	Scan List Table.....	131
22.6.2	GPS Combination.....	112	23.7.4	Priority 1/ Priority 1 Zone-CH	131
22.6.3	GPS Report Mode	113	23.7.5	Priority 2/ Priority 2 Zone-CH	132
22.6.4	Number of Times.....	113	23.7.6	Revert CH/GID	132
22.6.5	GPS Report Interval Time (Ignition On)	114	23.7.7	Dropout Delay Time	133
22.6.6	GPS Report Interval Time (Ignition Off)	114	23.7.8	Dwell Time.....	133
22.6.7	GPS Time Mark.....	114	23.7.9	Lookback	133
22.6.8	GPS Message Type	114	23.7.10	Scan Type	133
22.6.9	GPS Report on Data Zone-CH/GID	114	23.7.11	AC Control.....	134
22.6.10	GPS Data Storage.....	115	23.7.12	Priority 1 Temporary Delete/Add	134
22.7	Stack.....	115	23.7.13	Priority 2 Temporary Delete/Add	134
22.7.1	Stores the Latest Received Messages..	117	23.7.14	Off-hook Scan	134
22.7.2	Caller ID Stack	118	23.7.15	Revert CH/GID Display	134
22.7.3	ID/Message Stack with Time Stamp	118	23.7.16	CH/GID Recall.....	134
22.7.4	Message Memory.....	118	23.7.17	Priority Channel Stop Tone	135
22.8	Timer Function	118	23.7.18	Power-on Scan.....	135
22.9	Configuring the FleetSync.....	118			
22.9.1	Own Fleet/ID	119	24 EMERGENCY MODE.....	136	
22.9.2	Unit ID Encode Block	119	24.1	Configuring Emergency Mode	136
22.9.3	Interfleet Call	119	24.1.1	Emergency CH/GID Type.....	137
22.9.4	FleetSync Baud Rate	119	24.1.2	Emergency Zone-CH/GID	137
22.9.5	Auto Reset Timer	120			
22.9.6	FleetSync II	120			
22.9.7	Manual Dialing.....	120			
22.9.8	Group ID.....	120			
22.9.9	GTC Count.....	121			
22.9.10	Number of Retries	121			
22.9.11	Transmit Busy Wait Time	121			
22.9.12	Maximum ACK Wait Time	121			

24.1.3	Emergency Cycle	137	26.2.10	TOR or Channel Busy	148
24.1.4	Locator Tone 1 Duration.....	137	26.2.11	TXS	148
24.1.5	Transmit Duration.....	137	26.2.12	AUX Out Status Message 1 - 3	148
24.1.6	Locator Tone 2 Duration.....	138			
24.1.7	Receive Duration.....	138			
24.1.8	Emergency Display	138	27 REMOTE CH/GID LIST	149	
24.1.9	Emergency Text	138	27.1	.. Jumping to the Specified Zone-CH/GID using the External Device Connected to the Transceiver.....	149
24.1.10	Emergency Mode Type	138			
24.1.11	Emergency Key Delay Time.....	139	28 VOX	150	
24.1.12	Emergency Mic Sense	139	28.1	Configuring the VOX Function	150
24.1.13	Locator Tone	139	28.1.1	VOX Gain Level.....	150
24.1.14	Emergency LED	139	28.1.2	VOX Delay Time.....	151
24.1.15	Background Transmission.....	139	28.1.3	TX Inhibit while Receiving	151
24.1.16	Man Down Switch Type.....	139	28.1.4	Cancel Operation	151
24.1.17	Man Down Delay Time	139	28.1.5	VOX Proceed Tone	151
24.1.18	Man Down Pre-alert	140			
24.1.19	Man Down Logic Type.....	140	29 VOICE SCRAMBLER.....	153	
24.1.20	Emergency ID.....	140	29.1	Configuring the Voice Scrambler	153
24.1.21	Emergency DTMF ID.....	140	29.1.1	Scrambler	153
24.1.22	Emergency Call Fleet.....	141	29.1.2	Scrambler Status Memory (Scrambler) .	153
24.1.23	Emergency Call ID	141	29.1.3	SC20-460 Scrambler.....	154
			29.1.4	Scrambler Status Memory (SC20-460 Scrambler).....	155
25 DATA COMMUNICATION	142		30 CLOCK	156	
25.1	Data Communications Configuration	142	30.1	Current Time Display	156
25.1.1	Data.....	142	30.2	Displaying the Time when the Transceiver is Turned ON	156
25.1.2	Data Zone-CH/GID.....	142	30.3	Configuring the Time.....	156
25.1.3	Data CH/GID Dwell Time	142	30.4	Adjustment Time	157
25.1.4	Data Transmission with QT/DQT	142			
25.1.5	COM port.....	143	31 VGS	158	
25.1.6	Data Override	143	31.1	Auto Recording	158
26 FUNCTION PORT.....	144		31.2	Voice Memo (Manual Recording)	158
26.1	Assigning Functions to the Auxiliary Input Ports.....	144	31.3	Auto Reply Message.....	159
26.1.1	Data PTT.....	144	31.4	Message Playback.....	160
26.1.2	External PTT (Voice).....	145	31.5	Voice Guide	162
26.1.3	External PTT (Data)	145	31.6	GPS Data Storage	163
26.1.4	CH/GID Select A-D.....	146	31.6.1	GPS Data Storage.....	163
26.1.5	DTC	146	31.6.2	Reading from GPS Data Storage.....	163
26.1.6	Speaker Mute	146			
26.1.7	Mic Mute.....	146			
26.1.8	External Monitor	146			
26.1.9	External Hook.....	147			
26.1.10	Emergency	147			
26.1.11	AUX In Status Message 1 - 3	147			
26.1.12	Display Off.....	147			
26.1.13	Data CH/GID Dwell Time	147			
26.1.14	Mic Sense.....	147			
26.2	Assigning Functions to AUX	147			
26.2.1	LOK	147			
26.2.2	COR	148			
26.2.3	TOR.....	148			
26.2.4	AUX A.....	148			
26.2.5	AUX B.....	148			
26.2.6	System Busy	148			
26.2.7	PTT Out.....	148			
26.2.8	Channel Busy	148			
26.2.9	COR or Channel Busy.....	148			

About this Manual

This manual describes the functions of the 180-Series Mobile and Portable and how to configure the various functions.

How to Read this Manual

This manual has the following sections. In each section, each function has the reference data in order to find the cross-referenced information. In this manual, the description of each function may have the corresponding reference in ■ Configuration using KPG-89D.

Function Reference (FUNC)

This section describes every function of the 180-Series Mobile and Portable.

Field Programming Reference (FPRG)

This section describes how to configure the transceiver using KPG-89D.

Modification Information (MOD)

This section describes how to modify the transceiver and how to install various options.

About Notations

The following notations are used in this manual.

[]:

The characters in parentheses indicate the name of the operating portion of the transceiver and the key of the PC.

""

The characters in these marks indicate the name of the functions, buttons, and menus displayed on the display of KPG-89D.

We have updated many function names of functions. Therefore, some functions names have been changed even though the operations remain the same. Refer to the comparison list for new/old function names.

Table 1-1 Comparison List for New/Old Function Names

New Name	Old Name
2-tone	2 Tone
3 Reference Level Adjustments	3 Point Adjustments
5 Reference Level Adjustments	5 Point Adjustments
Autodial	Auto Dial
Battery Saver	Battery Save
End of Transmit	End of TX
Key Beep	Key Press Tone
Key-entry Error Tone	Key Input Error Tone
Low Transmit Power	Low Power
Low Transmit Power	RF Power Low
Manual Dialing	Manual Dial
Off-hook	Off Hook
On-hook	On Hook
Optional Board	Option Board
Optional Signaling	Option Signalling
OST Status Memory	OST Back Up
Password Authorization Tone	Password agreement Tone
Power-on Scan	Power On Scan
Power-on Text	Power On Text
Power-on Tone	Power On Tone
Pre-alert	Pre-Alert
Read Authorization Password	Read Password
Receive Frequency	RX Frequency
Ringer Tone	Ringing Tone
Scrambler Status Memory	Scrambler Backup
Sidetone	Side Tone
Signal Strength Indicator	Signal Meter
Single Reference Level Adjustment	1 Point Adjustment
Store & Send	Store&Send
Stun-off Tone	Stun Off Tone
Stun-on Tone	Stun On Tone
Time-out Timer	Time Out Timer
Tone Off	Selectable No Tone
TOT	T.O.T.
Transceiver	Radio
Transceiver Password	Radio Password
Transceiver-kill	Radio-kill
Transmit Frequency	TX Frequency
Transmit Power	TX Power
Trunking Logic Board	Trunking Board
Turn-off Code	Turn off Code

New Name	Old Name
TX Inhibit while Receiving	TX Inhibit on Receive
Warning Tone	Warning Alert Tone
While Transmitting	On TX
Zone Name Text Length	Zone Name Text length

Following are abbreviations used in this manual. Refer to the abbreviation list.

Table 1-2 Abbreviation List

Abbreviation	Full Spelling or its meaning
ACK	Acknowledgement
ANI Board	Automatic Numbering Identification Board
ANT	Antenna
AQUA	Kenwood's audio signal processing IC
AUX	Auxiliary
BCL	Busy Channel Lockout
BOT	The beginning of transmission
CH	Channel
COM port	Communication port
COR	Carrier Operated Relay
Dec ID	Decode ID code
deg	degree(s)
Del	Delete
DQT	Digital Quiet Talk code
DTC	Data Transmission Control
DTMF	Digital Tone Multi Frequency
Enc ID	Encode ID code
EOT	The end of transmission
EXT	The end of Text
Ext. PTT	an external PTT switch
FEC	Forward Error Correction
GID	Group ID code
GPS	Global Positioning System
GTC	Go to channel
Hi	High
I/O	Input/ Output
KDS-100	Kenwood Data Terminal
KGP-2A/2B	GPS/ Modem Unit
LOK	Link OK (connected to the repeater)
LTR ID	ID used in the Logic Trunked Radio system
MI2	Microphone Input II
Mic	Microphone
Mid	Medium
MSK	Minimum Shift Keying
OST	Operator Selectable Tone
PA	Public Address

Abbreviation	Full Spelling or its meaning
PF	Programmable Function
PSTN	Public Switched Telephone Network
PTT ID	PTT (Push-to-talk) ID code
QT	Quiet Talk signaling
RSSI	Received Signal Strength Indication
RTC	Real Time Clock
RX	Reception, Receiver
RXD	Received exchange data
RXVCO	Receiver's variable carrier oscillator
STX	Start of Text
SW	Switch
TA	Talk Around
TEL	Telephone
TOR	Tone Operated Relay
TOT	Time-out Timer
TX	Transmission, Transmitter
TX LED	Transmission LED
TXD	Transmitted exchange data
TXS	Transmission Sense
TXVCO	Transmitter's variable carrier oscillator
UTC	Universal Time Coordinated
VGS-1	Voice Guide and Storage Unit
VOX	Voice-operated Transmission
w/QT/DQT	With QT signaling and DQT code
w/STE	With Squelch Tail Eliminator

About Trademark

IBM® is a trademark or a registered trademark of International Business Machines Corporation.

Microsoft Windows® 98, Windows® Me, Windows® 2000, Windows® XP and Windows logo are registered trademarks of Microsoft Corporation.

LTR (Logic Trunked Radio) is a registered trademark of E. F. Johnson company.

Other company names and product names are trademarks or registered trademarks of the companies.

Outline

■ About the TK-2180/ 3180

TK-2180/ 3180 is a VHF/UHF portable transceiver that supports Conventional and LTR Trunking system.

■ About the TK-7180/ 8180

TK-7180/ 8180 is a VHF/UHF mobile transceiver that supports Conventional and LTR Trunking system.

■ Features

- You can easily configure the data in each channel using KPG-89D.
- You can configure each Zone as a Conventional Group or a Trunking system.
- You can configure a maximum of 128 Zones to Conventional/Trunking Groups.
- You can configure a maximum of 250 CH/GID for each zone and a maximum of 512 CH/GID to each transceiver.
- The transceiver has the D-sub 25-pin connector on its back. (TK-7180/ 8180 only)
- The transceiver is equipped with the VOX function. (TK-2180/ 3180 only)
- The transceiver supports FleetSync II.
- The transceiver has a entry level Scrambler function.
- The transceiver supports the following optional boards.
 - Voice Scrambler: SC20-460 (Transcrypt)
 - ANI Board: QE-2 (Cimarron)
 - GPS Receiver: GPS35-HVS, GPS15L (Garmin) (TK-7180/ 8180 only)
 - Voice Guide & Storage Unit: VGS-1
- The transceiver can perform Dual Priority Scan using two Priority Channels.
- The transceiver has the password function to protect its configuration data.

- The transceiver displays battery status. (TK-2180/ 3180 only)
- This transceiver has a time display function.

■ About the Programming Software

You can configure the transceiver's functions using KPG-89D. You can write the configuration data to the transceiver by connecting it to the PC using the KPG-36/46 programming cable. In this manual, the description of each function in the Function Reference may have a corresponding reference in the Field Programming Reference. Therefore, you can configure the function by referring to the function also appearing in the Field Programming Reference.

1 BASIC FUNCTION

1.1 Functions and Panel Layout

1.1.1 TK-2180/ 3180

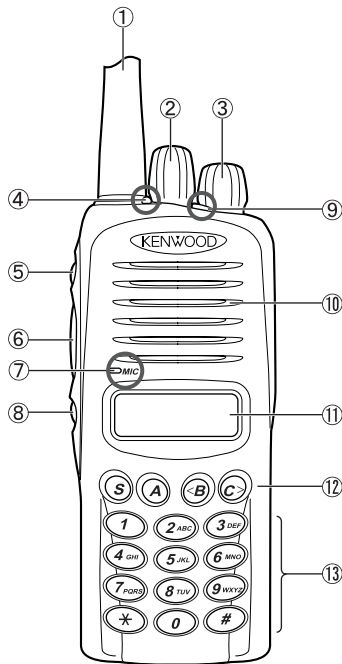

Figure 1-1 TK-2180/ 3180 Front View

- ① Antenna
This is the transceiver's antenna.
- ② Selector
You can configure the Zone and CH/GID using this selector.
- ③ Power Switch/Volume Control
You can turn the transceiver ON by rotating this switch. The **Volume** control allows you to adjust the volume level of the speaker.
- ④ TX LED/BUSY LED
These LEDs light when sending or receiving a signal (Refer to 3 DISPLAY.)
- ⑤ Side 1 key
You can activate the assigned function with this key.
- ⑥ PTT switch
Press this switch to transmit.
- ⑦ Microphone
This is the transceiver's microphone.
- ⑧ Side 2 key
You can activate the assigned function with this key.

- ⑨ AUX key
You can activate the assigned function with this key.
- ⑩ Speaker
The speaker emits the received audio signals and alert tones.
- ⑪ LCD Display
The channel number and the transceiver's status appear on this display.
- ⑫ PF keys
Press any key to activate a function assigned to each function key.
- ⑬ Keypad
Press any key to activate a function assigned to each function key or enter the number. (12 Keypad models only)

1.1.2 TK-7180/ 8180

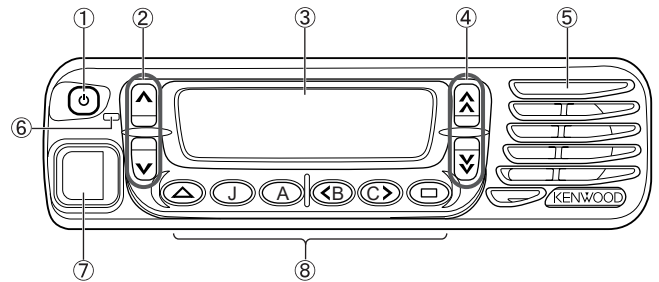

Figure 1-2 TK-7180/ 8180 Front View

- ① Power Switch
Press this switch to turn the transceiver ON and press it again to turn it OFF.
- ② [▲]/[▼] key
The **Volume** control allows you to adjust the volume level of the speaker.
You can activate the assigned function with this key.
- ③ [▲]/[▼] key
The channel number and the transceiver's status appear on this display.
You can activate the assigned function with this key.
- ④ [Up]/[Down] key
You can configure the Zone and CH/GID using this selector.
- ⑤ Speaker
The speaker emits the received audio signals and alert tones.
- ⑥ TX LED/BUSY LED
These LEDs light when sending or receiving a signal. (Refer to 3 DISPLAY.)
- ⑦ Microphone connector
You can connect a microphone using this connector.

1 BASIC FUNCTION

⑧ PF keys

Press any key to activate a function assigned to each function key.

Table 1-1 Assigning Signals to the 25-pin External Connector

Pin Number	Pin Name	Input/Output	Description
1	NC	-	No connection
2	RXD 1	Input	Serial data input 1
3	TXD 1	Output	Serial data input 1
4	AUX I/O 9	Input/Output	Auxiliary I/O 9
5	DI	Input	Data signal input
6	MI2	Input	External Mic Input
7	GND	-	Ground
8	AUX I/O 8	Input/Output	AUX I/O 8
9	TXD 2	Output	Serial data input 2
10	RXD 2	Input	Serial data input 2
11	GND	-	Ground
12	AUX I/O 7	Input/Output	Auxiliary I/O 7
13	AUX I/O 6	Input/Output	Auxiliary I/O 6
14	SB	-	Power output in conjunction with the Power switch
15	AUX OUT 2	Output	Auxiliary OUT 2
16	AUX OUT 1	Output	Auxiliary OUT 1
17	AFO	Output	RX Filtered Audio Output
18	GND	-	Ground
19	DEO	Output	Detected Signal Output
20	AUX I/O 5	Input/Output	Auxiliary I/O 5
21	AUX I/O 4	Input/Output	Auxiliary I/O 4
22	AUX I/O 3	Input/Output	Auxiliary I/O 3
23	AUX I/O 2	Input/Output	Auxiliary I/O 2
24	AUX I/O 1	Input/Output	Auxiliary I/O 1
25	ME	-	Mic Ground

Table 1-2 Assigning Signals to the 8-pin External Connector

Pin Number	Pin Name	Input/Output	Description
1	BLC	Output-	MIC Backlight Control
2	PSB	Input	DC 13.6 V
3	E	-	Ground
4	PTT/TXD	Input/Output	PTT: PTT IN TXD: Serial Output
5	ME	-	Mic Ground
6	MIC	Input	MIC Signal Input
7	HOOK/RXD	Input	HOOK: HOOK Detection RXD: Serial DATA IN
8	DM	Input/Output	MIC DATA Detection

Table 1-3 Assigning Signals to the 26-pin Internal Connector

No.	Name	Option	Input/Output	Description
1	OPT1	Scrambler	Output	CODE 1
		ANI	Output	CH BUSY
		VGS-1	Input	BUSY
2	OPT3	Scrambler	Output	CODE 2
		ANI	Input	KEY
		VGS-1	Input	PLAY
3	RXD1	Scrambler	-	-
		ANI	-	-
		VGS-1	Input	SO
4	TXD1	Scrambler	-	-
		ANI	-	-
		VGS-1	Output	SI
5	CK	Scrambler	-	-
		ANI	-	-
		VGS-1	Output	CLK
6	OPT4	Scrambler	Output	PTT
		ANI	Output	PTT
		VGS-1	Output	ENABLE
7	USEL	Scrambler	-	-
		ANI	-	-
		VGS-1	-	USEL
8	OPT5	Scrambler	Output	CODE 4
		ANI	Output	EMER
		VGS-1	Output	RESET
9	DGND	Scrambler	-	-
		ANI	-	-
		VGS-1	-	D-GND

No.	Name	Option	Input/Output	Description
10	AGND	Scrambler	-	GND
		ANI	-	A-GND
		VGS-1	-	A-GND
11	AI	Scrambler	-	-
		ANI	-	-
		VGS-1	Input	AO
12	AO	Scrambler	-	-
		ANI	-	-
		VGS-1	Output	AI
13	AGND	Scrambler	-	GND
		ANI	-	A-GND
		VGS-1	-	A-GND
14	5C	Scrambler	-	-
		ANI	Output	5C
		VGS-1	Output	5C
15	SIDETONE	Scrambler	-	-
		ANI	Input	STONE
		VGS-1	-	-
16	DAT IN	Scrambler	-	-
		ANI	Input	DO
		VGS-1	-	-
17	TCTL	Scrambler	-	-
		ANI	Input	TCONT
		VGS-1	-	-
18	Man Down (TK-2180/3180) NC (TK-7180/8180)	Scrambler	-	-
		ANI	-	-
		VGS-1	-	-
19	AUDIH	Scrambler	-	-
		ANI	Input	AUDIH
		VGS-1	-	-
20	OPT2	Scrambler	Output	OPT
		ANI	Output	AUX I/O
		VGS-1	-	-
21	TXO	Scrambler	Output	TX IN
		ANI	-	-
		VGS-1	-	-
22	RXEO	Scrambler	Output	RX IN
		ANI	-	-
		VGS-1	-	-
23	RXEI	Scrambler	Input	RX OUT
		ANI	-	-
		VGS-1	-	-

No.	Name	Option	Input/Output	Description
24	TXI	Scrambler	Input	TX OUT
		ANI	-	-
		VGS-1	-	-
25	OPT6	Scrambler	Output	CODE 3
		ANI	-	-
		VGS-1	-	-
26	SB2 (TK-2180/3180) 8C (TK-7180/8180)	Scrambler	Output	8C
		ANI	-	-
		VGS-1	-	-

Table 1-4 Assigning Signals to the 14-pin External Connector

Pin Number	Name	Description
1	SPI	Front Panel Speaker input
2	GND	Ground
3	8C	8 V Power Supply
4	SB	Power Supply (Switched B)
5	RA	Audio Output (for SP-MIC)
6	PSW	Power Switch Control Input
7	MIC	Mic Input
8	ME	Mic Ground
9	PSENS	Panel Sense. Input
10	TXD	Serial Data Output
11	RXD	Serial Data Input
12	GND	Ground
13	SHIFT	Beat Shift Output
14	RST2	Sub-u com Reset Output

1.2 Zone Description

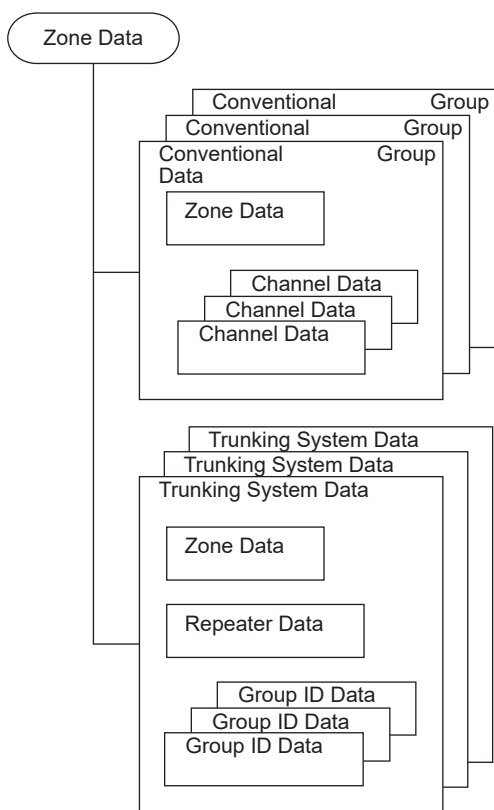

Figure 1-3 Zone Description

You can configure Conventional Groups/Trunking Systems for each Zone using KPG-89D.

You can configure a maximum of 128 Zones for each transceiver.

Conventional Groups consist of Simplex and Semi-duplex Conventional Channels.

Trunking Systems consist of Group IDs (GIDs) that utilize the LTR (Logic Trunked Radio) Trunking protocol.

You can configure each Zone as a Conventional Group or a Trunking System.

You can configure a maximum of 250 CH/GIDs for each zone and a maximum of 512 CH/GIDs for each transceiver.

Note:

- ◆ The number of Zones that you can configure varies depending on the number of CH/GIDs and Repeaters.
- ◆ The number of CH/GIDs that you can configure to each Zone varies depending on the number of Zones and Repeaters.

1.3 Transmit/Receive Frequency

This is a frequency pair used for transmitting and receiving data.

In Conventional Groups, you can configure the transmit/receive frequencies for each channel using KPG-89D.

In Trunking Systems, you can configure transmit/receive frequencies for each Repeater using KPG-89D.

Table 1-5 Transmit/Receive Frequency, Step

Model	Type	Transmit/Receive Frequency	
		Range [MHz]	Step [KHz]
TK-2180	K	136 - 174	2.5/ 5.0/ 6.25/ 7.5
TK-3180	K	400 - 470 *1 450 - 520	5.0/ 6.25
TK-7180	K	136 - 174	2.5/ 5.0/ 6.25/ 7.5
TK-8180	K	400 - 470 *1 450 - 520	5.0/ 6.25

*1: Supporting the updated version.

■ Configuration using KPG-89D

- Configuring the transmit frequency and the receive frequency to a channel. (Refer to 6.3.3 Receive Frequency, 6.3.4 Transmit Frequency.)
- Configuring the transmit frequency and the receive frequency to the Home Repeater (Refer to 6.4.3 Receive Frequency and 6.4.4 Transmit Frequency.)

1.4 Transmit Output Power

Select Low when a repeater or the receiving party is nearby to save power.

This will extend the serviceable operation time of the TK-2180/ 3180.

You can configure the transmit output power for each CH/GID using KPG-89D.

Table 1-6 Transmit Output Power: Low/High

Model	Transmit Output Power [W]	
	Low	High
TK-2180	1	5
TK-3180	1	5
TK-7180	5	30
TK-8180	5	30 (400 - 490 MHz) 25 (490 - 520 MHz)

■ Configuration using KPG-89D

- Configuring the transmit output power (High/Low) to a channel (Refer to 6.3.8 Transmit Power.)
- Configuring the transmit output power (High/Low) to the Group ID (Refer to 6.6.6 Transmit Power.)

1.5 Channel Spacing

Channel Spacing is the operational bandwidth of a channel used for communication.

In Conventional Groups, you can configure the Channel Spacing to each channel using KPG-89D. In Trunking System, you can configure the Channel Spacing to each Zone.

Table 1-7 Channel Spacing: Wide/Narrow

Model	Channel Spacing [kHz]	
	Wide	Narrow
TK-2180/ 7180	25	12.5
TK-3180/ 8180	25	12.5

■ Configuration using KPG-89D

- Configuring the Channel Spacing (Wide/Narrow) to a channel (Refer to 6.3.9 Wide/Narrow.)
- Configuring the Channel Spacing (Wide/Narrow) to a repeater (Refer to 6.5.3 Wide/Narrow.)

1.6 Squelch Level

The squelch level is the level at which the speaker unmutes on a received signal.

You can decrease the Squelch level to listen to weak radio signals and increase the level to tune out unwanted weak radio signals.

Table 1-8 Squelch Level

Range	0	1 - 9
		Mute function is completely disabled.
Step	1	

■ Transceiver operation

Follow the procedures below to adjust the Squelch Level.

1. Press the **PF Squelch Level** key.

The icon lights on the LCD and the current Squelch Level appears.

“” icon lights.



TK-2180/ 3180



TK-7180/ 8180

2. Select the Squelch Level.

The Squelch Level changes according to the selection.

● Common

Press **[B]** to increase the Squelch Level.

Press **[C]** to decrease the Squelch Level.

● TK-2180/ 3180 *1

Turn the Selector clockwise to increase the Squelch Level.

Turn the Selector counterclockwise to decrease the Squelch Level.

● TK-7180/ 8180

[^]/[v] keys to increase/decrease the Squelch Level.

*1 The List Selection key (Selector) is enabled.



TK-2180/ 3180



TK-7180/ 8180

3. Press [S].

The Squelch Level changes and the LCD returns to normal display. “” icon is also turned Off.

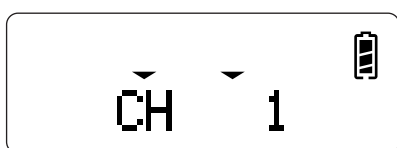

TK-2180/ 3180



TK-7180/ 8180

Note:

- ◆ The Squelch Level operates only in Conventional Groups.
- ◆ Signalling is disabled while configuring the Squelch Level
- ◆ Following are the operations of the keys while changing the Squelch Level.

Table 1-9 Key Operation

Key Name	Operation
Selector/ [▲]/ [▼]	Increase/decrease the digit number, Squelch Level confirmation * The List Selection key (Selector) is enabled.
[Side 1]/ [△]	Exit mode.
[S]	Exit mode.
[A]	
[B]	Increase/decrease the digit number, Squelch Level confirmation
[C]	Increase/decrease the digit number, Squelch Level confirmation
[Side 2]/ [■]	
[0] - [9]	
[*]	Exit mode.
[#]	
PTT switch	Exit PTT Mode and transmission.

■ **Configuration using KPG-89D**

- Configuring the Squelch Level to the transceiver (Refer to 6.7.4 Conventional tab - Squelch Level.)
- Assigning functions to the PF keys (Refer to 6.8 Key Assignment.)

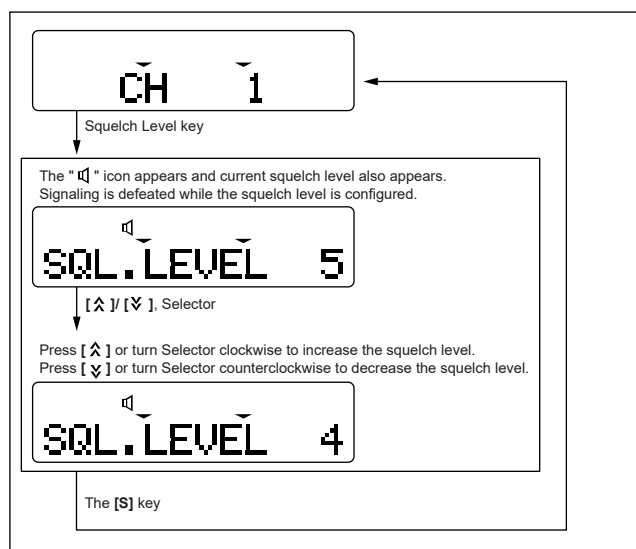

Figure 1-4 Squelch Level

1.7 Compander

The Compander is used to improve the S/N ratio of a the transmitted audio signal by compressing it at the transmitting party and expanding it at the receiving party. You can enable/disable this function using the KPG-89D. The transmitting party and the receiving party must have the same configuration to use this function.

■ **Configuration using KPG-89D**

- Configuring the Compander function to each channel (Refer to 6.3.15 Compander.)
- Configuring the Compander function to each GID (Refer to 6.6.14 Compander.)

1.8 Beat Shift

This function eliminates the problems of the transceiver's internal beat caused by internal oscillators.

The harmonic of the oscillator may interfere with reception. You can prevent this problem by slightly shifting the frequency of the oscillator.

You can enable/disable this function using KPG-89D.

You can enable and disable the Beat Shift function of the VGS-1 when the transceiver has the VGS-1 installed .

■ Configuration using KPG-89D

- Configuring the Beat Shift function (Refer to 6.3.14 Beat Shift and 6.4.5 Beat Shift.)

1.9 Key Lock

(TK-2180/ 3180 only)

This function allows you to disable the operation of the transceiver's keys.

You can use this function to prevent the inadvertent operation of the transceiver when wearing the transceiver at your waist, etc.

You can enable/disable this function using KPG-89D.

Following is the list showing the operable keys and inoperable keys when the Key Lock function is enabled.

Table 1-10 Functions that you can assign with the Keypad Operation

Key Lock	Keys
Inoperable keys	Selector Top Side key Front key Mic Switch
Operable keys	PF Emergency key PF Backlight key PF Monitor key PF Monitor Momentary key PF Squelch Off key PF Squelch Off Momentary key PF Function key PF Key Lock key

Note:

- This function is only available for the TK-2180/ 3180.
- The Transceiver Password activates before this function operates when the Transceiver Password is assigned. The Key Lock function activates when the Transceiver Password is disabled.

■ Transceiver Operation

● Enabling the Key Lock function

- Press and hold the **PF Key Lock** key for more than one second to enable the Key Lock function.

“LOCKED” appears on the LCD and the transceiver's keys are locked.

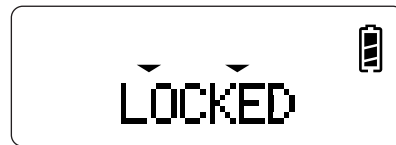

TK-2180/ 3180



TK-7180/ 8180

● Disabling the Key Lock function

- Press the **PF Key Lock** key when the Key Lock function is enabled.

The Key Lock function is disabled.

■ Configuration using KPG-89D

- Assigning functions to the **PF** keys (Refer to 6.8 Key Assignment.)

1.10 Keypad Operation

You can configure the operation of the keypad according to the desired usage of the transceiver.

You can assign the frequently used function to the Keypad.

You can configure the Keypad Operation using KPG-89D. The following is the list of functions that you can assign to the transceiver with a Keypad.

Table 1-11 Available Functions

Configuration	Operation
OST (Operator Selectable Tone)	You can directly select one of the OST List from OST List 1 - 40 by pressing the keypad of the transceiver.
Channel Entry	You can directly select the channel by pressing the keypad of the transceiver.

1 BASIC FUNCTION

Configuration	Operation
DTMF (Autodial)	<p>You can directly select and transmit the DTMF code by pressing the keypad of the transceiver.</p> <p>You can select the Autodial List configured with KPG-89D.</p> <p>You can also select and transmit the DTMF code when the Store & Send function is enabled.</p> <p>You can perform the same operation by pressing the PF Autodial key.</p>
DTMF (Keypad Auto PTT)	<p>You can directly transmit the DTMF code by pressing the keypad of the transceiver.</p>
FleetSync (Selcall)	<p>You can make a FleetSync Selcall by pressing the keypad of the transceiver.</p> <p>You can select the Selcall List configured with KPG-89D and make a SelCall.</p> <p>You can enter and transmit the Selcall ID code when the Manual Dialing function is enabled.</p> <p>You can perform the same operation by pressing the PF Selcall key.</p>
FleetSync (Status)	<p>You can transmit the FleetSync Status by pressing the keypad of the transceiver.</p> <p>You can select the Status List configured with KPG-89D and transmit the status.</p> <p>You can enter and transmit the Status data number code when the Manual Dialing function is enabled.</p> <p>You can perform the same operation by pressing the PF Status key.</p>
FleetSync (Selcall + Status)	<p>You can transmit the FleetSync Selcall + Status by pressing the keypad of the transceiver.</p> <p>You can select the Selcall List/Status List configured with KPG-89D and make a SelCall.</p> <p>You can enter and transmit the Selcall/Status code when the Manual Dialing function is pressed.</p> <p>You can perform the same operation by pressing the PF Selcall + Status key.</p>

Note:

- ◆ This function is only available for the TK-2180/ 3180.
- ◆ You can use this function when the TK-7180/ 8180 uses the Microphone with 12/16 keys.

■ Configuration using KPG-89D

- Configuring the Keypad Operation (Refer to 6.8.2 General Tab - Keypad Operation.)

1.11 Call Key

This function allows you to transmit FleetSync, Status, 2-tone, or DTMF code with a single operation.

You can directly transmit Status, 2-tone, and DTMF codes configured with KPG-89D by pressing one of the **PF Call 1 - Call 6** keys. The timing to transmit FleetSync, 2-tone, and DTMF codes vary depending on the parameters of FleetSync, 2-tone, and DTMF. The FleetSync code is transmitted to the target Fleet/ID.

You can assign functions to the **PF Call 1** to **PF Call 6** keys using KPG-89D.

■ Configuration using KPG-89D

- Configuring the **Call** key (Refer to 6.8.7 Call tab.)

1.12 Mic Sense Control

This function allows you to adjust the Mic Gain in Emergency Mode and the input terminal, such as External PTT.

You can switch the Mic Sense Control between Normal and High level. There is a 4 dB gain difference between the Normal level and High level.

You can configure the Mic Sense Control using KPG-89D.

Note: You can only configure External PTT (Voice) to the TK-7180/ 8180.

■ Configuration using KPG-89D

- Configuring the Mic Sense function (Refer to 6.7.1 Common-Page 1 tab - Mic Sense.)
- Configuring the Emergency Mic Sense function (Refer to 6.14.12 Emergency Mic Sense.)
- Configuring the Mic Sense (External PTT (Voice)) (Refer to 6.15.3 AUX tab - Mic Sense.)

1.13 Battery Saver

(TK-2180/ 3180 only)

This function allows the transceiver to receive intermittently in order to reduce power consumption.

The transceiver receives intermittently in the following conditions.

- There is no carrier.
- When no key is pressed for more than 5 seconds while there is a carrier and the QT/DQT does not match.

You can save the battery consumption by extending the Battery Saver time. However, you may miss hearing the beginning of the received call if you extend this duration. You may have to extend the duration between the time when the transceiver transmits and the time you start communicating with the receiving party.

You can configure the Battery Saver function using KPG-89D. Following is the list of the interval for the transceiver to receive intermittently.

Table 1-12 Interval for the Transceiver to Receive Intermittently

Save	No Carrier	QT/DQT is Unmatched.
Off	Off	Off
Short	200 ms	400 ms
Medium	400 ms	800 ms
Long	800 ms	1600 ms

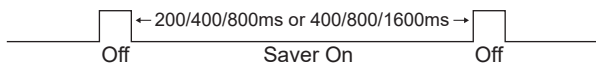

Figure 1-5 Battery Saver

■ Configuration using KPG-89D

- Configuring the Battery Saver function (Refer to 6.7.3 Common-Page 3 tab - Battery Saver.)

1.14 Power Switch Status Memory

(TK-7180/ 8180 only)

This function turns the transceiver ON/OFF when connecting the power connector in conjunction with the Power Switch Status Memory configuration stored in the transceiver.

You can enable/disable the Power Switch Status Memory function using KPG-89D.

Table 1-13 Operation of the Power Switch Status Memory

Configuration	Operation
Enabled	The transceiver is turned ON when connecting the power connector after removing it while the transceiver was turned ON. The transceiver remains turned OFF when connecting the power connector after removing it while the transceiver was turned OFF. In this case, you must press the Power switch to turn the transceiver ON.
Disabled	The transceiver is turned ON when connecting the power connector regardless of the transceiver's condition.

■ Configuration using KPG-89D

- Configuring the Power Switch Status Memory (Refer to 6.7.1 Common-Page 1 tab - Power Switch Status Memory.)

1.15 Mic PTT

(TK-7180/ 8180 only)

This is the PTT switch attached to the microphone of the KMC-35/36.

You can configure the Mic PTT using KPG-89D. Following are the functions of the Mic PTT.

Table 1-14 Configuring the Mic PTT

Configuration	Operation
Modulation Line	You can select the Modulation line to be activated for the Mic PTT. Below is a list of the modulation lines. Normally, only the Mic line is modulated. <ul style="list-style-type: none"> • Mic line (the sound of the Mic located on the front of the transceiver) • MI2 Line (the sound modulation of the D-sub connector located on the rear of the transceiver) • DI Line (the data modulation of the D-sub connector)
w/QT/DQT	You can configure the QT/DQT configured to the Conventional Group channel to be overwritten when receiving with the Mic PTT. Normally, you can configure the QT/DQT to be overwritten.
w/STE	You can configure the STE (Squelch Tail Eliminator) to be transmitted after transmitting the QT/DQT code configured in the Conventional Group channel. Normally, you can configure the STE to be transmitted.

■ Configuration using KPG-89D

- Configuring the Mic Line (Refer to 6.15.5 Modulation Line tab - Mic Line.)
- Configuring the MI2 Line (Refer to 6.15.5 Modulation Line tab - MI2 Line.)
- Configuring the DI Line (Refer to 6.15.5 Modulation Line tab - Di Line.)
- Configuring the w/QT/DQT Line (Refer to 6.15.5 Modulation Line tab - w/QT/DQT.)
- Configuring the w/STE Line (Refer to 6.15.5 Modulation Line tab - w/STE.)

2 BASIC OPERATION

2.1 Turning the Transceiver ON/OFF

2.1.1 Turning the Transceiver ON

You can turn the transceiver ON/OFF by pressing the **Power** switch.

You can also turn the transceiver ON using the Ignition Sense terminal. (Refer to 8 Ignition Sense.)

■ When Data is Written in the Transceiver and No Password is Configured:

1. Press the **Power** switch.

The Power-on Tone A sounds for 500 ms and all LCD segments light.

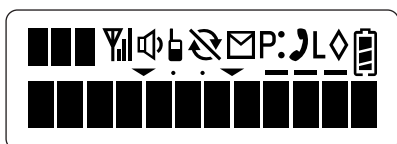

TK-2180/ 3180

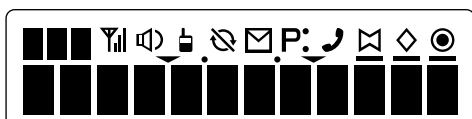

TK-7180/ 8180

The Power-on Text appears for 2 seconds if the Power-on Text is configured. (Refer to 3.6.6 Power-on Text.)



TK-2180/ 3180



TK-7180/ 8180

The CH/GID Name or Zone-CH/GID number appears on the display. (Refer to 3.6.5 Display Character.)



TK-2180/ 3180



TK-7180/ 8180

■ If the Password is Configured:

1. Press the **Power** switch.

"Password" appears on the LCD when turning the transceiver ON. (Refer to 5.1 Transceiver Password.)



TK-2180/ 3180



TK-7180/ 8180

2. Enter the password.

The Power-on Tone A sounds for 500 ms and all LCD segments light when the correct password is entered.

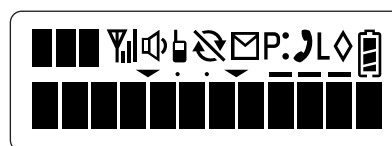

TK-2180/ 3180



TK-7180/ 8180

The Power-on Text appears for 2 seconds if the Power-on Text is configured. (Refer to 3.6.6 Power-on Text.)



TK-2180/ 3180

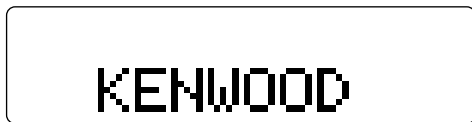

TK-7180/ 8180

The CH/GID Name or Zone-CH/GID number appears on the display. (Refer to 3.6.5 Display Character.)

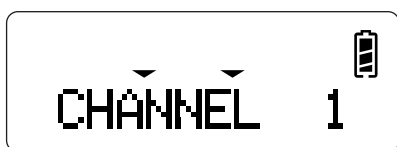

TK-2180/ 3180



TK-7180/ 8180

■ When no Data is Written to the Transceiver:

1. Press the **Power** switch.

"UNPROGRAM" appears on the LCD when turning the transceiver ON.



TK-2180/ 3180



TK-7180/ 8180

2.1.2 Turning the Transceiver OFF

Press the **Power** switch to turn the transceiver OFF.

You can also turn ON/OFF the transceiver using the Ignition Sense function. (Refer to 8 Ignition Sense.)

2.2 Adjusting the Volume

You can increase the Volume level by turning the **Volume** control clockwise and decrease it by turning the control counterclockwise for the TK-2180/ 3180.

Press [**▲**] to increase the volume or [**▼**] to decrease the volume for the TK-7180/ 8180.

2.3 Using Function Keys

Press a key to activate a function assigned to each function key. (Refer to 10 Key Assignment.)

2.4 Changing the Zone

You can change the Zone number using the **Selector**, the **PF Zone Up** key, and the **PF Zone Down** key.

Although scan pauses if you change the Zone number during scan, the Transceiver resumes scanning after 1 second.

The transceiver skips Zone numbers that are not configured when changing the Zone number.

The Rollover Tone sounds when the Zone Number reaches the lowest number.

■ Transceiver Operation

- Using the **Selector**
 - Turn the **Selector** clockwise.
The Zone number increases in steps of 1.
 - Turn the **Selector** counter-clockwise.
The Zone number decreases in steps of 1.
- Using **PF** keys
 - Press the **PF Zone Up** key.
The Zone number increases in steps of 1.
 - Press and hold the **PF Zone Up** key for more than one second.
The Zone number increases in steps of 1 every 200 ms.
 - Press the **PF Zone Down** key.

The Zone number decreases in steps of 1.

- Press and hold the **PF Zone Down** key for more than one second.

The Zone number decreases in steps of 1 every 200 ms.

■ Configuration using KPG-89D

- Assigning functions to the **PF** keys (Refer to 6.8 Key Assignment.)

2.5 Changing the CH/GID

You can change the CH/GID using the **Selector**, the **PF Zone Up** key, and the **PF Zone Down** key. (Refer to 10 Key Assignment.)

Although scan pauses if you change the CH/GID number during scan, the transceiver resumes scanning in 1 second.

The unregistered CH/GID number is skipped when changing the CH/GID number.

The Rollover Tone beeps when the CH/GID Number reaches at the lowest number.

■ Transceiver Operation

- Using the **Selector**
 - Turn the **Selector** clockwise.
The CH/GID number increases in steps of 1.
 - Turn the **Selector** counterclockwise.
The CH/GID number decreases in steps of 1.
- Using the **PF** keys
 - Press the **PF CH/GID Up** key.
The CH/GID number increases in steps of 1.
 - Press and hold the **PF CH/GID Up** key for more than one second.
The CH/GID number increases in steps of 1 every 200 ms.
 - Press the **PF CH/GID Down** key.
The CH/GID number decreases in steps of 1.
 - Press and hold the **PF CH/GID Down** key for more than one second.
The CH/GID number decreases in steps of 1 every 200 ms.

■ Configuration using KPG-89D

- Assigning functions to the **PF** keys (Refer to 6.8 Key Assignment.)

2.6 Channel Entry

This function allows you to directly change the CH/GID number.

You can specify the CH/GID number in the current Zone by entering numbers after pressing the **Channel Entry** key.

The transceiver automatically recognizes the highest channel number. You can enter the digit number and specify the channel.

• Transceiver Operation

- **When the Maximum Channel Number is Three Digits Number:**
 1. Press the **PF Channel Entry** key.
The transceiver enters Channel Entry Mode.
 2. Enter the Channel number.
To enter channel 250, press **[2]**, **[5]**, and **[0]**.
 3. To enter channel 90, press **[0]**, **[9]**, and **[0]**.
To enter channel 7, press **[0]**, **[0]**, and **[7]**.
- **When the maximum channel number is two digits number:**
 1. Press the **PF Channel Entry** key.
The transceiver enters Channel Entry Mode.
 2. Enter the Channel number.
To enter channel 90, press **[9]** and **[0]**.
To enter channel 07, press **[0]** and **[7]**.
- **When the maximum channel number is one digit number:**
 1. Press the **PF Channel Entry** key.
The transceiver enters Channel Entry Mode.
 2. Enter the Channel number.
To enter channel 7, press **[7]**.

2 BASIC OPERATION

Note:

- ◆ When no key is pressed before the Mode Reset Timer expires in Channel Entry Mode, the display returns to the last display.
- ◆ When the unregistered channel is entered, the transceiver specifies the channel used before the transceiver enters Channel Entry Mode.
- ◆ Although scan pauses when changing the channel during scan, the transceiver resumes scanning in 1 second.
- ◆ When the transceiver receives a call on the previous channel while entering the channel number, the transceiver emits the received tone in Channel Entry Mode. You can move to a new channel after receiving a call.
- ◆ Following are the operations of key operations while entering the channel number.

Table 2-1 Key Operation

Key Name	Operation
Selector/ [▲]/ [▼]	Up/Down of the Channel * List Selection Key (Selector) is enabled.
[Side 1]/ [△]	Exit mode.
[S]	Confirm the channel number.
[A]	Delete a character.
[B]	
[C]	
[Side 2]/ [■]	
[0] - [9]	Enter the number.
[*]	Confirm the CH/GID.
[#]	Delete a character.
PTT switch	

■ Configuration using KPG-89D

- Assigning functions to the PF keys (Refer to 6.8 Key Assignment.)

2.7 Home CH/GID

This function allows you to jump to the frequently used CH/GID with a press of a key. You can jump to the CH/GID in the same Zone.

You can change the Home CH/GID using the PF key when the Operator Selectable function is enabled with KPG-89D.

You can configure the Home CH/GID using KPG-89D.

Note: Refer to Scan Function for the operations when the PF Home CH/ GID key is pressed during scan.

■ Transceiver Operation

- Jumping to the Home Channel/Group ID
 1. Press the Home CH/GID key.
“HC” appears on the Sub display and the transceiver jumps to the Home CH/GID in the selected Zone.



TK-2180/ 3180



TK-7180/ 8180

- Returning to the previous CH/GID
 1. Press the PF Home CH/GID key on the Home CH/GID.
The transceiver returns to the previous CH/GID and “HC” on the Sub display disappears.



TK-2180/ 3180



TK-7180/ 8180

- Changing the Home Channel/Group ID
 1. Select the CH/GID to be used as the Home CH/GID.



TK-2180/ 3180



TK-7180/ 8180

2. Press and hold the **PF Home CH/GID** key for more than 3 seconds.

The transceiver emits the Key Beep C and configures the Home CH/GID. In this case, "HC" appears on the Sub display.



TK-2180/ 3180



TK-7180/ 8180

■ Configuration using KPG-89D

- Configuring the Home Channel (Refer to 6.2.3 Home Channel.)
- Configuring the Home GID (Refer to 6.5.6 Home GID.)
- Configuring the Home Channel Operator Selectable function (Refer to 6.2.4 Home CH Operator Selectable.)
- Configuring the Home GID Operator Selectable function (Refer to 6.5.7 Home GID Operator Selectable.)
- Assigning functions to the **PF** keys (Refer to 6.8 Key Assignment.)

2.8 Direct CH/GID

This function allows you to jump to the registered CH/GID with a press of a key. You can jump to the CH/GID in a different Zone, instantly.

You can change the Home CH/GID using the **PF** key when the Operator Selectable function is enabled with KPG-89D.

You can configure the Direct CH/GID function using KPG-89D.

Note: Refer to Scan Function for the operations performed when pressing one of the **PF Direct CH/GID 1 - 5** keys during scan. (Refer to 23.1.4 Manually Changing the Zone-CH/GID during Scan.)

■ Transceiver Operation

- Jumping to the Direct CH/GID

1. Press the **PF Direct CH/GID** key.

The "DRn" icon appears on the Sub display. You can jump to the Direct CH/GID in other than the current Zone. The corresponding value is entered on "n" on the Sub display.

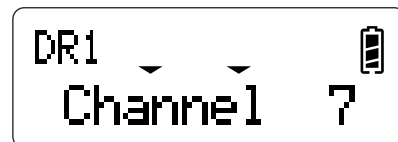

TK-2180/ 3180



TK-7180/ 8180

- Returning to the previous CH/GID

1. Press the **PF Direct CH/GID** key on the Direct CH/GID.

The transceiver returns to the previous CH/GID and "DRn" on the Sub display disappears.



TK-2180/ 3180



TK-7180/ 8180

Note: You can use this function when the Return function in the **Key Assignment** window > Direct CH/GID is enabled.

- Changing the Direct CH/GID

1. Select the CH/GID to be used as the Direct CH/GID.



TK-2180/ 3180



TK-7180/ 8180

2. Press and hold the one of the **PF Direct CH/GID 1 - 5** keys for more than 3 seconds.

The transceiver emits the Key Beep C and configures the Direct CH/GID. In this case, "DRn" appears on the Sub display.



TK-2180/ 3180



TK-7180/ 8180

■ Configuration using KPG-89D

- Configuring the Direct CH/GID (Refer to 6.8.8 Direct CH/GID tab - CH/GID.)
- Configuring the Direct Channel Operator Selectable function (Refer to 6.8.8 Direct CH/GID tab- Operator Selectable.)
- Configuring the Return function (Refer to 6.8.8 Direct CH/GID tab - Return.)
- Assigning functions to the **PF** keys (Refer to 6.8 Key Assignment.)

2.9 Receive

2.9.1 Conventional Group

The transceiver emits the received tone only when the received QT/DQT code matches with the configured QT/DQT code. The transceiver emits the received tone when the QT/DQT code matches.

You must configure the Receive Frequency and the QT/DQT Decode using KPG-89D.

■ Transceiver Operation

1. Select the Zone-Channel. (Refer to 2.4 Changing the Zone, 2.5 Changing the CH/GID.)
2. Adjust the volume when receiving a call if needed. (Refer to 2.2 Adjusting the Volume.)

■ Configuration using KPG-89D

- Configuring the Receive Frequency (Refer to 6.3.3 Receive Frequency.)
- Configuring the QT/DQT Decode (Refer to 6.3.5 QT/DQT Decode)

2.9.2 Trunking System

The transceiver emits the received tone only when the received LTR ID matches with the configured LTR ID. The transceiver emits the received tone when the LTR ID matches.

You must configure the Receive Frequency and the Decode ID using KPG-89D.

■ Transceiver Operation

1. Select the Zone-Group. (Refer to 2.4 Changing the Zone, 2.5 Changing the CH/GID.)
2. Adjust the volume when receiving a call if needed. (Refer to 2.2 Adjusting the Volume.)

■ Configuration using KPG-89D

- Configuring the Receive Frequency (Refer to 6.4.3 Receive Frequency.)
- Configuring the Decode GID (Refer to 6.6.4 Decode ID.)

2.10 Transmit

2.10.1 Conventional Group

The transceiver transmits the programmed QT/DQT while pressing the **PTT** switch to transmit. When the transmitted QT/DQT code matches the QT/DQT code configured in the receiving party's transceiver, you can communicate with the receiving party.

The Reverse Burst and the Turn-off code in QT are transmitted when releasing the **PTT** switch to close the speaker of the receiving party's transceiver.

You must configure the Transmit Frequency and the Encode ID using KPG-89D.

■ Transceiver operation

1. Select the Zone-Channel. (Refer to 2.4 Changing the Zone, 2.5 Changing the CH/GID.)
2. Confirm that the channel is available.
3. Speak into the microphone while pressing the **PTT** switch.
4. Release the **PTT** switch to finish transmitting.

■ Configuration using KPG-89D

- Configuring the Transmit Frequency (Refer to 6.3.4 Transmit Frequency.)
- Configuring the QT/DQT Encode (Refer to 6.3.6 QT/DQT Encode.)

2.10.2 Trunking System

The transceiver sends the LTR ID while pressing the **PTT** switch to transmit. The transceiver connects to the repeater and waits to acknowledge the data that is echoed back. If the data is correct, the transceiver assumes the connection is properly established and re-transmits a call to the receiving party.

When the transmitted LTR ID matches the LTR ID configured in the receiving party's transceiver, you can communicate with the receiving party.

The transceiver transmits the EOT data when the **PTT** switch is released to close the squelch of the receiving party's transceiver.

You must configure the Transmit Frequency and the Encode ID using KPG-89D.

■ Transceiver Operation

1. Select the Zone-Group. (Refer to 2.4 Changing the Zone, 2.5 Changing the CH/GID.)
2. Press the **PTT** switch.
3. Speak into the microphone.
4. Release the **PTT** switch.

The transceiver returns to the receiving mode.

■ Configuration using KPG-89D

- Configuring the Transmit Frequency (Refer to 6.4.4 Transmit Frequency.)
- Configuring the Encode ID (Refer to 6.6.3 Encode ID.)

2.11 Transmitting with Talk Around

This function allows you to communicate to another transceiver without using a repeater. (Refer to 13 Talk Around.)

2.11.1 Conventional Group

■ Transceiver Operation

1. Select the Zone-Group. (Refer to 2.4 Changing the Zone, 2.5 Changing the CH/GID.)
2. Press the **PF Talk Around** key.
3. Press the **PTT** switch.

The transceiver transmits on the Receive Frequency using the Receive QT/DQT instead of the Transmit Frequency and the Transmit QT/DQT to make a call.

2.11.2 Trunking System

■ Transceiver Operation

1. Select the Talk Around Group.
2. Press the **PTT** switch or the **PF Talk Around** key.

The transceiver transmits on the Receive Frequency using the Receive QT/DQT instead of the Transmit Frequency and the Transmit QT/DQT to make a call.

3 DISPLAY

The transceiver has the following display and indicator.

LED (TX/Busy)

LCD Display

Backlight

3.1 BUSY LED

The BUSY LED lights green when receiving the following signals.

- Receiving a carrier in the Conventional Group
- Receiving Data in PC Mode, Firmware Programming Mode and Clone Mode.

You can configure the Busy LED to light when receiving a carrier in Conventional Group using KPG-89D.

You can configure the TX LED and BUSY LED to light to communicate in Emergency Mode using KPG-89D.

■ Configuration using KPG-89D

- Configuring the Busy LED to light (Refer to 6.7.4 Conventional tab ñ Busy LED.)
- Configuring the TX LED and the Busy LED to light in Emergency Mode (Refer to 6.14.3 Emergency LED.)

3.2 TX LED

The TX LED lights red when transmitting in the following situations.

- Transmitting in Conventional Group and Trunking System
- Transmitting Data in PC Mode, Firmware Programming Mode, or Clone Mode.

You can configure the TX LED and the BUSY LED to light to communicate in Emergency Mode using KPG-89D.

■ Configuration using KPG-89D

- Configuring the TX LED and the Busy LED to light in Emergency Mode (Refer to 6.14.3 Emergency LED.)

3.3 LCD Display

The LCD Display of the transceiver is as follows.

■ TX-2180/3180

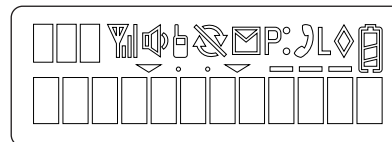

☒ 3-1 TK-2180/3180 LCD

■ TX-7180/8180

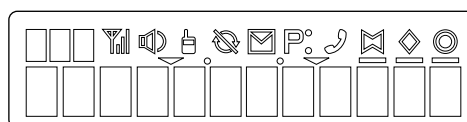

☒ 3-2 TK-7180/8180 LCD

■ Available characters for the Main Display and the Sub Display

0	1	2	3	4	5	6	7	8	9		
A	B	C	D	E	F	G	H	I	J	K	L
N	O	P	Q	R	S	T	U	V	W	X	Y
a	b	c	d	e	f	g	h	i	j	k	l
n	o	p	q	r	s	t	u	v	w	x	y
	!	"	#	\$	%	&	'	()	*	+
-	.	/	:	<	=	>	?	@	[\]
_	`	{		}	~						

☒3-3 Available characters for the Main Display and the Sub Display

3.3.1 Backlight

(TK-2180/3180 only)

The backlight LEDs are located behind the LCD and the Keypad. You can see the LCD using the backlight in dark places or at the night.

Press the PF Backlight key to light the backlight LED.

The backlight LED lights when pressing any key other than the PTT switch and/or turning the Volume Control.

The Backlight lights for approximately 5 seconds and turns Off when no key is pressed after it turns On.

■ Configuration using KPG-89D

- Assigning functions to the PF keys (Refer to 6.8 Key Assignment.)

3.3.2 LCD Brightness

(TK-7180/8180 only)

You can adjust the brightness of the backlight LED when using it in dark places or at night.

You can change the brightness of the backlight LED in 3 levels by pressing the PF LCD Brightness key. The brightness changes in the following order: High – Low–Off. The configuration of the backlight LED brightness is stored even if the transceiver is turned OFF.

You can also configure the brightness of the backlight LED using KPG-89D.



■ Configuration using KPG-89D













- Configuring the LCD Brightness Level (Refer to 6.7.1 Common-Page 1 tab - LCD Brightness.)
- Assigning functions to the PF keys (Refer to 6.8 Key Assignment.)





3.4 Icons

The transceiver has the following icons.

表 3-1 Icon List

Icon	Function
	<ul style="list-style-type: none"> RSSI icon This icon indicates the signal strength.
	<ul style="list-style-type: none"> Priority Channel icon This icon represents the Priority Channel status. There are three types of Priority Channel icons. P: : Priority 1 Channel P: : Priority 2 Channel P: : Priority 1 & 2 Channel

Icon	Function
	<ul style="list-style-type: none"> Monitor On icon This icon displays the status of the Monitor function and the signaling.
	<ul style="list-style-type: none"> Scan Mode icon This icon indicates the status of the Scan. There are two types of Scan Mode icons. Solid: Performing or pausing the Scan Blink: Inhibiting the Scan during Scan Mode.
	<ul style="list-style-type: none"> Telephone ID icon Solid: Displaying the status of the Telephone ID Blink: Displaying the status of the Auto Telephone Search
	<ul style="list-style-type: none"> Message Stack icon This icon indicates the status of the Message Stack. There are two types of Scan Mode icons. Lighting: Operating in Auto Recording Mode Flashing: Writing data in memory while the transceiver is in Auto Recording Mode
	<ul style="list-style-type: none"> Talk Around icon This icon indicates the status of the Talk Around function.
	<ul style="list-style-type: none"> Horn Alert icon This icon indicates the status of the Horn Alert function.
	<ul style="list-style-type: none"> Scrambler icon This icon indicates the status of the Scrambler function.
	<ul style="list-style-type: none"> Public Address icon (TK-7180/8180 only) This icon indicates the status of the Public Address function.
	<ul style="list-style-type: none"> Low Transmit Power icon (TK-2180/3180 only) This icon indicates the status of the Low Transmit Power function.
	<ul style="list-style-type: none"> Zone Add icon This icon indicates the status of the Zone Add function.
	<ul style="list-style-type: none"> CH/GID Add icon This icon indicates the status of the CH/GID Add function.
	<ul style="list-style-type: none"> AUX A/VOX icon The status of the AUX A appears for the TK-7180/ 8180 and the status of the VOX function appears for the TK-2180/3180.





Icon	Function
 (Middle)	<ul style="list-style-type: none"> AUX B/VOX icon The status of the AUX B is displayed for the TK-7180/ 8180 and the status of the VOX function is displayed for the TK-2180/3180.
 (Right)	<ul style="list-style-type: none"> Operator Selectable Tone icon This icon displays the status of the Operator Selectable Tone.
 (Left)	<ul style="list-style-type: none"> Auto Recording icon This icon displays the status of the Auto Recording function.
 (Right)	<ul style="list-style-type: none"> Auto Reply Message icon This icon is displayed in Auto Reply Message Mode .
	<ul style="list-style-type: none"> Battery Indicator icon This icon displays the status of the Battery Indicator. This icon appears only when using the TK-2180/3180.

3.4.1 Signal Strength Indicator

This function allows you to display the transceiver's information.

When this function is enabled, the signal strength of the receive signal appears.

表 3-2 Signal Status

Icon	Status	Signal Strength (dBm)	
		TK-2180/3180	TK-7180/8180
	High	-80 -	-74 -
	Medium	-95 - -80	-92 - -74
	Low	-110 - -95	-110 - -92
	Very weak	Carrier exits. -110	Carrier exits. -110
None	No signal	No carrier	No carrier

Note: The signal strength in room temperature is used as the indication.

3.4.2 Battery Status/Warning

(TK-2180/3180 Only)

This function notifies and warns the battery's remaining status to the user.

The battery status is displayed in 4 levels when this function is enabled.

With this function enabled, the transceiver emits the Beep or displays the warning when the battery voltage level becomes low.

You can enable/disable this function using KPG-89D.

表 3-3 Battery Status Icon List





Icon	Status
	High
	Sufficient
	Low
	Very Low

表 3-4 Battery Warning Operation

Battery Warning	Operation
Off	You can transmit regardless of the Battery voltage and the Battery warning display does not appear.
While transmitting	The TX LED blinks red while transmitting.
Always	The TX LED blinks red while transmitting.
Always w/beep	The TX LED always blinks red and the transceiver emits the Battery Warning Tone.

Note:

- ◆ The status of the alkaline batteries cannot be displayed.
- ◆ Select "Always" or "Always w/beep" in the While transmitting configuration.

■ Configuration using KPG-89D

- Configuring the Battery Status (Refer to 6.7.3 Common-Page 3 tab - Battery Status.)
- Configuring the Battery Warning (Refer to 6.7.3 Common-Page 3 tab - Battery Warning.)

3.5 Sub Display

The Sub display can display 3 characters. You can select the items to be displayed on the Sub display using KPG-89D.

- None (No items are displayed.)
- Zone number
- CH/GID number
- OST number

The following characters appear depending on the situation.

表 3-5 Sub LCD List

Sub LCD Display	Function
RCL	<ul style="list-style-type: none"> • CH/GID Recall This icon appears when jumping to the last received Zone-CH/GID using the Channel/Group ID Recall function during Scan. (Refer to 23.7.16 CH/GID Recall)
CID	<ul style="list-style-type: none"> • FleetSync Caller ID This icon appears when the received PTT ID (FleetSync ID) is displayed on the Main Display with the Caller ID Display. (Refer to 22.1.1 Caller ID Display)
I01	<ul style="list-style-type: none"> • FleetSync SelCall ID This icon appears when selecting the caller's ID of the received call in Stack Mode. (Refer to 22.7 Stack)
S01	<ul style="list-style-type: none"> • FleetSync Status Message This icon appears when selecting the Status Message in Stack Mode. (Refer to 22.7 Stack)
M01	<ul style="list-style-type: none"> • FleetSync Short Message This icon appears when selecting the Short Message in Stack Mode. (Refer to 22.7 Stack)
CAL	<ul style="list-style-type: none"> • Call Indicator This icon appears when receiving a call in Trunking System. This CAL icon flashes when receiving the LTR Group ID. The CAL icon lights when receiving the LTR Fix ID. (Refer to 17.2.6 Call Indicator)
HC	<ul style="list-style-type: none"> • Home Channel This icon appears when jumping to the Home Channel. (Refer to 2.7 Home CH/GID)
DR1 - DR5	<ul style="list-style-type: none"> • Direct Channel This icon appears when jumping to the Direct Channel. (Refer to 2.8 Direct CH/GID)

Sub LCD Display	Function
1 - 128	<ul style="list-style-type: none"> • Zone number The selected Zone number appears.
1 - 250	<ul style="list-style-type: none"> • CH/GID number The selected CH/GID number appears.
V01	<ul style="list-style-type: none"> • VGS Recording Mode The VGS recording Mode icon appears. (Refer to 31 VGS)
01-100	<ul style="list-style-type: none"> • List number display The selected List number appears.
FNC	<ul style="list-style-type: none"> • Function On This icon appears when pressing the PF Function key. The transceiver enters Key Entry Mode until the 2nd Function key is pressed.
OSP	<ul style="list-style-type: none"> • Priority Channel Configuration Mode This display appears when the transceiver enters in Priority Channel Configuration Mode.

■ Configuration using KPG-89D

- Configuring the Sub display (Refer to 6.7.1 Common-Page 1 tab - Sub Display.)

3.6 Main Display

You can configure the following items for the Main Display.

- Zone Name
- Zone Name Text Length
- Channel Name
- GID Name
- Display Character
- Power-on Text

Note: Following characters are available.

表 3-6 Available characters

```
(space)!"#$%&'()*+,-./01234567
89:;<=>?@[\\]^_`ABCDEF GHIJ
KLMNOPQRSTUVWXYZabcdefghijklmnop
ghijklmnopqrstuvwxyz{|}~
```

3.6.1 Zone Name

This function allows you to assign a name to a Zone.

You can configure a maximum of 12 characters for each Zone. You can assign the Zone Name to recognize each channel easily.

A part of the Zone Name appears on the display when both Zone Name and Zone Name Text Length are configured. (Refer to [3.6.2 Zone Name Text Length](#))

You can configure the Zone Name using KPG-89D.

■ Configuration using KPG-89D

- Configuring the Zone Name (Conventional Group) (Refer to [6.2.1 Zone Name](#).)
- Configure the Zone Name (Trunking System) (Refer to [6.5.1 Zone Name](#).)

3.6.2 Zone Name Text Length

This function allows you to display a part of the Zone Name on the Main Display.

You can configure the number of characters for the Zone Name that appears on the Main Display.

You can configure the Zone Name Text Length using the KPG-89D.

表 3-7 Zone Name Text Length Display (example)

Function	Configuration
Zone Name Text Length	3
Zone Name	KENWOOD
GID Name	-CHANNEL1-
Displayed Characters	

■ Configuration using KPG-89D

- Configure the Zone Name Text Length (Refer to [6.7.1 Common-Page 1 tab - Zone Name Text Length](#).)

3.6.3 Channel Name

This function allows you to assign a name to a Channel.

You can configure a maximum of 12 characters to each Channel. You can assign the Channel Name to recognise each Channel easily.

You can configure the Channel Name using KPG-89D.

■ Configuration using KPG-89D

- Configuring a Channel Name (Refer to [6.3.7 Channel Name](#).)

3.6.4 GID Name

This function allows you to assign a name to a Group ID.

You can configure a maximum of 12 characters to a Group ID. You can assign the GID Name to recognize each Group ID easily.

You can configure the GID Name using KPG-91D.

■ Configuration using KPG-89D

- Configuring a GID Name (Refer to [6.6.5 GID Name](#).)

3.6.5 Display Character

You can select the type of the characters (CH/ GID Name or Zone-CH/GID Number) that appears on the Main Display.

You can switch CH/GID and Zone-CH/GID Number by pressing the PF Display Character key.

You can configure the display character using KPG-89D.

■ Configuration using KPG-89D

- Configuring the Display Character (Refer to [6.7.1 Common-Page 1 tab - Display Character](#).)
- Assigning functions to the PF keys (Refer to [6.8 Key Assignment](#).)

3.6.6 Power-on Text

You can configure a text that appears when the transceiver is turned ON.

The configured message appears for two seconds after the transceiver is turned ON.

You can configure the Power-on Text using KPG-89D.

Note:

- ◆ The Power-on Text disappears if a key is pressed while the Power-on Text is displayed.
- ◆ The Power-on Text does not appear when the Transceiver Password is configured.

■ Configuration using KPG-89D

- Configuring the Power-on Text (Refer to 6.7.2 Common-Page 2 tab - Text.)

3.6.7 Volume Indicator

(TK-7180/8180 Only)

This function allows you to display the Volume Level (sound level of the receiving signal) on the Main Display.

The current Volume Level appears on the Main Display when the volume is adjusted. The level is displayed for one second in the range of 0 to 31.

4.1 Tone Pattern

The following tones are available.

Table 4-1 Tone List

Tone Classification	Description, Type
Power-on Tone	The tone notifies you that the transceiver is turned ON. <ul style="list-style-type: none"> • Power-on Tone A • Power-on Tone B
Control Tone	This tone sounds when operating the transceiver. <ul style="list-style-type: none"> • Key Beep A • Key Beep B • Key Beep C • Key-entry Error Tone • Rollover Tone • Password Authorization Tone • Queue Tone • Free System Ringback Tone • System Search Mode Tone • Ringer Tone • Priority Channel Tone • Scan Stop Tone
Warning Tone	This tone sounds to warn you. <ul style="list-style-type: none"> • Warning Tone • TOT Pre-alert Tone • Battery Warning Tone • PLL Unlock Tone • Busy Tone • Timed Power-off Tone • Delay Tone • Intercept Tone • Deny Tone • System Search Tone • System Search End Tone
Locator Tone	This tone sounds when starting/finishing the automatic transmission in Emergency Mode. <ul style="list-style-type: none"> • Duration of Locator Tone
Sidetone	This tone sounds when a channel becomes available or finishing the transmission. <ul style="list-style-type: none"> • PTT Proceed Tone • VOX Proceed Tone • PTT ID Sidetone

4.1.1 Power-on Tone

This tone sounds when the transceiver is turned ON or OFF.

Table 4-2 Power-on Tone List

Function	Description
Power-on Tone A	This tone sounds when the transceiver is turned ON.
Power-on Tone B	This tone sounds when pressing and holding the Power switch for more than 1 second.

4.1.2 Control Tone

This tone sounds when accepting the operation.

Table 4-3 Control Tone List

Function	Description
Key Beep A	This tone sounds when the function is enabled by pressing the key.
Key Beep B	This tone sounds when the function is disabled by pressing the key.
Key Beep C	This tone sounds when writing data, such as DTMF Memory or Test Mode adjustment value, to the transceiver by pressing the key.
Key-entry Error Tone	This tone sounds when denying the operation activated by pressing a key. This tone sounds when pressing an inoperable key in SelCall Entry/OST Select Mode.
Rollover Tone	This tone sounds when selecting the minimum Zone number or the minimum CH/GID.
Password Authorization Tone	This tone sounds when the Password matches.
Queue Tone	This tone sounds when searching an available RIC repeater that can be connected through the Auto TEL function in Trunking System. This tone keeps sounding until an available RIC repeater is found or the Auto TEL function expires within 60 seconds.
Free System Ringback Tone	This tone sounds when entering in Free System Ringback Mode in Trunking System.
System Search Mode Tone	This tone sounds when the transceiver enters in System Search Mode in Trunking System.
Ringer Tone	This tone sounds when a repeater is available in Free System Ringback Mode in Trunking System.
Priority Channel Tone	This tone sounds when the Scan pauses on the Priority Channel.
Scan Stop Tone	The transceiver jumps to the Home Channel or the Direct Channel when the PF Home CH key or the PF Direct key is pressed during Scan. The transceiver emits this tone every 5 seconds while pausing the Scan.

4.1.3 Warning Tone

This tone sounds to warn you for many functions.

Table 4-4 Warning Tone List

Function	Description
Warning Tone	This tone sounds until the PTT switch is released when inhibiting transmit with the TOT or no transmission frequency. In Conventional Groups, this tone sounds until the PTT switch is released while the Busy Channel Lock is enabled.
TOT Pre-alert Tone	This tone sounds when the transmission inhibit period configured in the TOT is about to expire.
Battery Warning Tone	This tone sounds when the Battery Warning Tone Battery reaches the configured minimum voltage.
PLL Unlock Tone	This tone sounds when the PLL unlock status is detected.
Busy Tone	This tone sounds when no repeater is available in Trunking Mode.
Timed Power-off Tone	This tone sounds when the Timed Power-off is about to expire.
Delay Tone	This tone sounds when the transceiver is trying to access the repeater 3 to 6 times in Trunking Mode by pressing the PTT switch. Therefore, the user is notified that the connection to the repeater will be delayed.
Intercept Tone	This tone sounds when the connection to the repeater fails while accessing the repeater by pressing the PTT switch.
Deny Tone	This tone sounds when the transceiver cannot be connected to RIC repeater within 60 seconds using the Auto TEL function in the Trunking Mode.
System Search Tone	This tone sounds when changing the System while performing the System Search in Trunking Mode.
System Search End Tone	This tone sounds when no repeater is available in Trunking Mode.

4.1.4 Locator Tone

This tone sounds when starting/finishing the automatic transmission in Emergency Mode.

Table 4-5 Locator Tone List

Function	Description
Locator Tone Duration	This tone sounds before/after making an automatic transmission in Emergency Mode.

4.1.5 Sidetone

This tone sounds when a channel becomes available or finishing the transmission.

Table 4-6 Sidetone List

Function	Description
PTT Proceed Tone	This tone sounds when the transceiver establishes the connection to the repeater by pressing the PTT switch in Trunking Mode. In Conventional Mode, you can use this tone to prevent the receiving party from missing calls. You can use this tone in conjunction with the Proceed Tone Delay Time.
VOX Proceed Tone	This tone sounds when transmitting while operating the VOX function.
PTT ID Sidetone	This tone sounds when sending the FleetSync PTT ID.

4.2 Minimum Volume

The Minimum Volume function in TK-2180/ 3180 is different from the Minimum Volume function in the TK-7180/ 8180.

You can configure this function using KPG-89D.

■ TK-2180/ 3180

This function allows you to control the minimum volume level when the **Volume** control is turned to its lowest level.

This prevents the user from missing a call even if the **Volume** control has been turned down. The volume level does not change from the full counterclockwise position to the Minimum Volume position. The transceiver mutes completely when turning the **Volume** control to the full counterclockwise position if the Minimum Volume is not configured.

■ TK-7180/ 8180

● Selecting “Preset” in Minimum Volume Type

The volume of the transceiver is automatically configured to the Minimum Volume level when the transceiver is turned ON even if the volume level was completely turned down and the transceiver was turned OFF.

● Selecting “Lowest Limit” in Minimum Volume Type,

This function allows you to limit the Minimum Volume level when the **Volume** control is turned to its lowest level.

This prevents the user from missing calls even if the **Volume** control has been turned down. The volume increases from the Minimum Volume Level when turning the **Volume** control clockwise. The transceiver mutes completely when turning the **Volume** control to the full counterclockwise position if the Minimum Volume is not configured.

■ Configuration using KPG-89D

- Configuring the Minimum Volume (Refer to FPRG 6.7.2 Common-Page 2 tab - Minimum Volume.)
- Configuring the Minimum Volume Type (Refer to FPRG 6.7.2 Common-Page 2 tab - Minimum Volume Type.)

4.3 Maximum Volume

(TK-2180/ 3180 only)

This function allows you to limit the maximum volume level when the **Volume** control is turned to fully clockwise.

This prevents a user from excessive volume when wearing the headset.

You can configure this function using KPG-89D.

■ Configuration using KPG-89D

- Configuring the Maximum Volume (Refer to FPRG 6.7.2 Common-Page 2 tab - Maximum Volume.)

4.4 Tone Volume Offset

This function allows you to configure the offset level from the volume level. You can use this function when adjusting the volume level of the tone.

You can configure this function using KPG-89D.

■ Configuration using KPG-89D

- Configuring the Tone Volume Offset (Refer to FPRG 6.7.2 Common-Page 2 tab - Tone Volume Offset.)

4.5 Tone Volume

You can configure the volume level of various tones using KPG-89D.

You can use this function when adjusting the volume level of the tone.

You can configure the Tone Volume for each tone using KPG-89D. You can configure the volume of the following tones.

Table 4-7 Available Tone Volume

Tone Volume	Operation
Current	The current tone operates in conjunction with the Tone Volume.
1 - 31	The transceiver emits tones with the fixed tone volume. Higher values result in greater volume.
Off	The transceiver does not emit any tones.
Selectable	The tone volume changes in conjunction with the PF Fixed Volume key. (Refer to 4.6 Selectable Tone Level.)

■ Configuration using KPG-89D

- Configuring the Power-on Tone (Refer to FPRG 6.7.2 Common-Page 2 tab - Power-on Tone.)
- Configuring Control Tones (Refer to FPRG 6.7.2 Common-Page 2 tab - Control Tone.)
- Configuring Warning Tones (Refer to FPRG 6.7.2 Common-Page 2 tab - Warning Tone.)
- Configuring Alert Tones (Refer to FPRG 6.7.2 Common-Page 2 tab - Alert Tone.)
- Configuring Sidetones (Refer to FPRG 6.7.2 Common-Page 2 tab - Sidetone.)
- Configuring Locator Tones (Refer to FPRG 6.7.2 Common-Page 2 tab - Locator Tone.)

4.6 Selectable Tone Level

This function allows you to adjust the Tone Volume using the **PF** key.

The volume level of the tone is configured to the **Optional Features** window the Common - Page2 tab - Low Volume Level (Fixed Volume) or High Volume Level (Fixed Volume) by pressing the **PF Fixed Volume** key.

You can configure the Selectable Tone Level using KPG-89D

■ Transceiver Operation

1. Press the **PF Fixed Volume** key.

The volume of the tone changes.

The tone volume changes in the following way.

Low Volume Level (Fixed Volume) - High Volume Level (Fixed Volume) - Off

■ Configuration using KPG-89D

- Configuring the Low Volume Level (Fixed Volume) (Refer to FPRG 6.7.2 Common-Page 2 tab - Low Volume Level (Fixed Volume).)
- Configuring the High Volume Level (Fixed Volume) (Refer to FPRG 6.7.2 Common-Page 2 tab - High Volume Level (Fixed Volume).)
- Assigning functions to the **PF** keys (Refer to FPRG 6.8 Key Assignment.)

4.7 Alert Tone Pattern

This function allows you to configure the Alert Tone pattern when receiving a call with DTMF/2-tone/FleetSync. You can select an Alert Tone matching your environment.

You can select a Alert Tone from eight patterns of Alert Tones. An Alert Tone pattern consists of 16 tones.

You can configure the Alert Tone Pattern using KPG-89D Below is a list of configuration items for the Alert Tone.

Table 4-8 Alert Tone Pattern

Alert Tone Pattern	Description
Frequency	You can configure the frequency of the tone. You can configure the frequency between 400 and 2500 Hz in steps of 10 Hz. The Gap can be configured when selecting "No Tone".
Length	You can configure the tone length. You can configure the tone length between 10 and 2500 ms in steps of 10 ms. No tone is emitted when selecting 0 ms.
Cycle	You can configure the number of times for the Alert Tone to sound. You can select the numbers from 1 to 255. The Alert Tone is emitted with no limitation when configuring the cycle to "Infinite". Any alert tone does not sound while the transceiver unmutes when emitting the Alert Tone several times. The Alert Tone is disabled when the match status of 2-tone/DTMF/FleetSync is released.
Interval	You can configure the interval time to repeat the Alert tone. You can configure the time between 0 and 255 s in steps of 1 s.

■ Configuration using KPG-89D

- Configuring the Alert Tone Pattern (Refer to FPRG 6.13 Special Alert Tone.)

4.8 PTT Release Tone

The PTT Release Tone sounds after the communication completes and the **PTT** switch is released. This tone notifies the receiving party that the transmission is finished. With this function, the receiving party can easily recognize the timing to transmit since the tone sounds when the caller finishes transmitting.

The PTT Release Tone is sent prior to end of the transmission, when the caller releases the **PTT** switch.

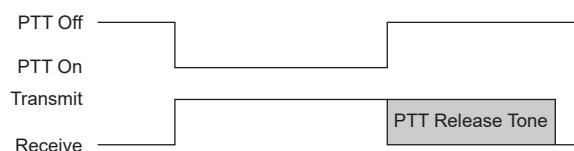

Figure 4-1 PTT Release Tone

4 SOUND

In Conventional Group, you can enable/disable this tone for each channel.

In Trunking system, you can enable/disable this tone when transmitting the Dispatch ID or Telephone ID. This helps avoid transmitting 2 or more different types of tones simultaneously, since some repeaters have a similar function for Telephone IDs.

You can enable/disable the PTT Release Tone using KPG-89D.

■ Configuration using KPG-89D

- Configuring the Control PTT Release Tone in Conventional Group (Refer to FPRG 6.7.4 Conventional tab - PTT Release Tone.)
- Configuring the PTT Release Tone (Dispatch) in Trunking System (Refer to FPRG 6.7.5 Trunking tab - Dispatch.)
- Configuring the PTT Release Tone (Dispatch) in Trunking System (Refer to FPRG 6.7.5 Trunking tab - Telephone.)

4.9 PTT Proceed Tone

This tone sounds when the channel becomes available after pressing the **PTT** switch. You can configure the Proceed Tone to sound.

In LTR Trunking System, a user should start transmitting when the repeater becomes available after pressing the **PTT** switch. However, this duration is not constant, so it is difficult for the user to confirm the time to start transmitting. With this tone enabled, the user can smoothly communicate by starting transmission after the Proceed Tone sounds.

You can also use this tone in the Conventional Group scan.

You can configure the Proceed Tone to sound using KPG-89D.

Note:

- ◆ The audio tone is not transmitted until the Proceed Tone sounds even if a user starts transmitting by pressing the **PTT** switch.
- ◆ When the PTT ID is configured to the channel while transmitting DTMF/2-tone/FleetSync, the PTT Proceed Tone configuration resets. In this case, the PTT ID Sidetone (FleetSync) or the Sidetone (DTMF) is enabled.

■ Configuration using KPG-89D

- Configuring the Proceed Tone (Refer to FPRG 6.7.4 Conventional tab - Proceed Tone, FPRG 6.7.5 Trunking tab - Proceed Tone.)

4.10 Proceed Tone Delay Time

This function allows the caller to emit the Proceed Tone when the configured Proceed Tone Delay Time expires.

You can use this tone to prevent the receiving party from missing calls.

You can configure the Proceed Tone Delay Time using KPG-89D. You can configure the Proceed Tone Delay Time for the caller in conjunction with the Decode speed of the receiving party.

Note: You cannot configure the Proceed Tone Delay Time when the Proceed Tone is disabled.

■ Configuration using KPG-89D

- Configuring the Proceed Tone Delay Time (Refer to FPRG 6.7.4 Conventional tab - Proceed Tone Delay Time and FPRG 6.7.5 Trunking tab - Delay Time.)

4.11 Speaker Attenuation

(TK-2180/ 3180 only)

This function allows you to temporarily attenuate the volume level of the speaker microphone.

You can use this function when using the transceiver in quiet places or the volume of the microphone is too loud.

You can normally enable this function and disable this function when making an important call, such as an emergency call.

Note:

- ◆ You can only configure this function to the **PF** key of the speaker microphone.
- ◆ The Speaker Attenuation function is disabled when pulling out the speaker microphone while this function is enabled.

■ Transceiver operation

● Enabling the Speaker Attenuation Function

1. Press the **PF Speaker Attenuation** key while the PF Speaker Attenuation function is disabled.

The Speaker Attenuation function is enabled and the volume decreases for 10 dB.

● Disabling the Speaker Attenuation Function

1. Press the **PF Speaker Attenuation** key while the PF Speaker Attenuation function is enabled.

The Speaker Attenuation function is disabled and the volume level returns to the previous level.

■ Configuration using KPG-89D

- Assigning functions to the **Mic** keys (Refer to FPRG 6.8 Key Assignment.)

4.12 Public Address

(TK-7180/ 8180 only)

This function allows you to use the transceiver and exterior speakers as a hailer.

When you speak into the microphone, the voice sounds from the exterior speaker (PA function).

Note:

- ◆ The Public Address function is automatically disabled when changing the CH/GID.
- ◆ You must install the KAP-2 and an external speaker (KES-5) to use this function.

■ Transceiver Operation

● Enabling the Public Address Function

1. Press the **PF Public Address** key.

The “” icon appears and the Address function is enabled.



TK-7180/ 8180

● Disabling the Public Address Function

1. Press the **PF Public Address** key while the PF Public Address function is enabled.

The “” icon disappears and the Public Address function is disabled.



TK-7180/ 8180

■ Configuration using KPG-89D

- Assigning functions to the **PF** keys (Refer to FPRG 6.8 Key Assignment.)

5 PASSWORD FUNCTION

The transceiver has a password function for transceiver operation and the configuration data.

5.1 Transceiver Password

This function protects the transceiver from unauthorized usage. The transceiver works normal when the correct Password is entered after the transceiver is turned ON.

You can configure the password using KPG-89D. You can configure a password using any numbers between 0 and 999999.

You can enter the password using the Mic key on the TK-7180/ 8180 or 12-key keypad of the TK-2180/ 3180. You can also enter the password using the **Selector** or the **PF** keys.

■ Transceiver Operation

● Using Mic Keypad or 12-key Keypad

1. Use the Mic key or number key on the 12/16-key keypad to enter the password.
2. Press **[S]** or **[*]** after you complete entering the password.

The Password Authorization Tone sounds when the correct password is entered.

“PASSWORD” appears on the LCD again when the wrong password is entered and the transceiver returns to Password Entry Mode.

● Using the Selector or the PF keys

1. Select a number using the **Selector** or **[▲]/[▼]**.
2. Press **[C]** to select the number.
The entered number stops blinking and is confirmed on the display.
3. Repeat the steps 1 and 2 to enter the entire password.
4. Press **[S]** or **[*]** when you complete entering the password.

The Password Authorization Tone sounds when the correct password is entered.

“PASSWORD” appears on the LCD again when the wrong password is entered and the transceiver returns to Password Entry Mode.

Note: Following keys can be used.

Table 5-1 Key Operation

Key Name	Operation
Selector/ [▲]/ [▼]	Increase/decrease the number (0 - 9)
[Side 1]/ [△]	The transceiver returns to the “PASSWORD” display.
[S]	Password Authorization

Key Name	Operation
[A]	Press: Delete a number. Hold: Delete all numbers.
[B]	
[C]	Confirm the selected value and the number.
[Side 2]/ [■]	
[0] - [9]	Enter a number.
[*]	Password authorization
[#]	Press: Delete a number. Hold: Delete all numbers.
PTT switch	

■ Configuration using KPG-89D

- Configuring the Transceiver Password (Refer to FPRG 6.7.1 Common-Page 1 tab - Transceiver Password.)
- Assigning functions to the **PF** keys (Refer to FPRG 6.8 Key Assignment.)

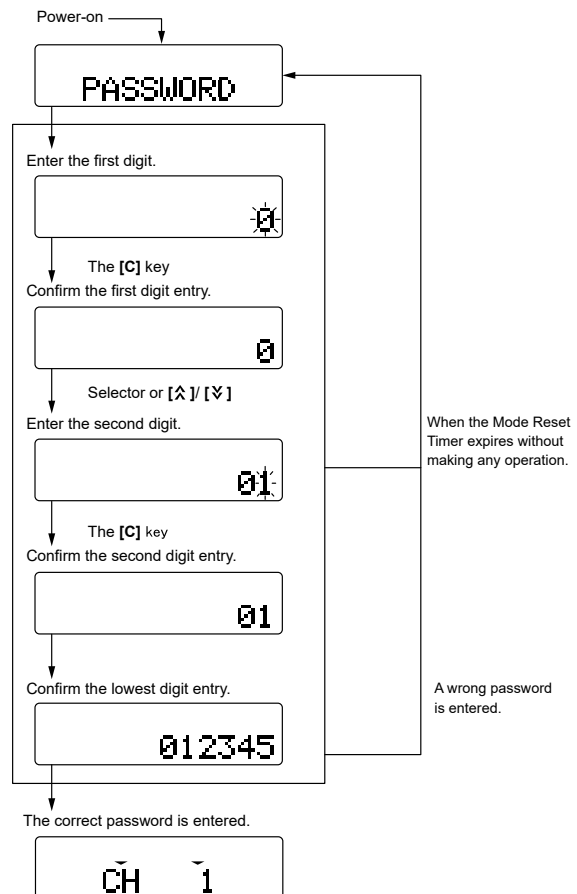

Figure 5-1 Transceiver Password Operation

5.2 Read Authorization Password

This password protects the configuration data and prevents the operating frequencies from being read by unauthorized persons.

You must enter the Read Authorization Password when reading the configuration data from the transceiver using KPG-89D. You cannot read the configuration data unless the correct Password is entered.

You cannot start cloning the configuration data unless the correct Read Authorization Password is entered when the Password is configured on the master transceiver.

You can configure the Read Authorization Password using KPG-89D. You can configure the Read Authorization Password using any numbers between 0 and 999999.

You can enter the Read Authorization Password using the Mic Keypad on the TK-7180/ 8180 or 12-keypad of the TK-2180/ 3180. You can also enter the password using the **Selector** or **PF** keys.

■ Transceiver Operation

● Using Mic Key or 12/16-key keypad

1. Press the Mic Keypad or keys on the 12/16-key keypad and enter the password.
2. Press **[S]** or **[*]** when you complete entering the password.

When the correct password is entered, the Master Transceiver Mode becomes ready for Cloning.

“CLONE LOCK” appears on the LCD again if the wrong password is entered and the transceiver returns to Password Entry Mode.

● Using the Selector or PF keys

1. Select a number using the **Selector** or **[^]/[v]**.
The selected characters blink.
2. Press **[C]** to confirm the entered characters.
The entered character stops blinking and becomes solid on the display.
3. Repeat the steps 1 and 2 to enter the entire password.
4. Press **[S]** or **[*]** after entering the password.
When the correct password is entered, the Master Transceiver Mode becomes ready for Cloning.
“CLONE LOCK” appears on the LCD again if the wrong password is entered and the transceiver returns to Password Entry Mode.

Note: Following keys can be used to enter the Read Authorization Password.

Table 5-2 Key Operation

Key Name	Operation
Selector/ [^]/ [v]	Increase/decrease the number (0 - 9)
[Side 1]/ [^]	The transceiver returns to the “CLONE LOCK” display.
[S]	Password authorization
[A]	Press: Delete a number. Hold: Delete all numbers.
[B]	
[C]	Confirm the selected value and the number.
[Side 2]/ [■]	
[0] - [9]	Enter the Digit number.
[*]	Password authorization
[#]	Press: Delete a number. Hold: Delete all numbers.
PTT switch	

■ Configuration using KPG-89D

- Configuring the Read Authorization Password (Refer to FPRG 6.7.1 Common-Page 1 tab - Read Authorization Password.)
- Configuring the Clone function (Refer to FPRG 6.7.2 Common-Page 2 tab - Clone.)

5.3 Overwrite Password

This function prevents the operating frequencies from being unintentionally.

You must enter the Overwrite Password from the PC when writing the configuration data to the transceiver using KPG-89D.

You can configure the Overwrite Password using KPG-89D. You can configure the Overwrite Password using any numbers between 0 and 999999.

Note: You cannot clone data to another transceiver if the Overwrite Password is configured.

■ Configuration using KPG-89D

- Configuring the Overwrite Password (Refer to FPRG 6.7.1 Common-Page 1 tab - Overwrite Password.)

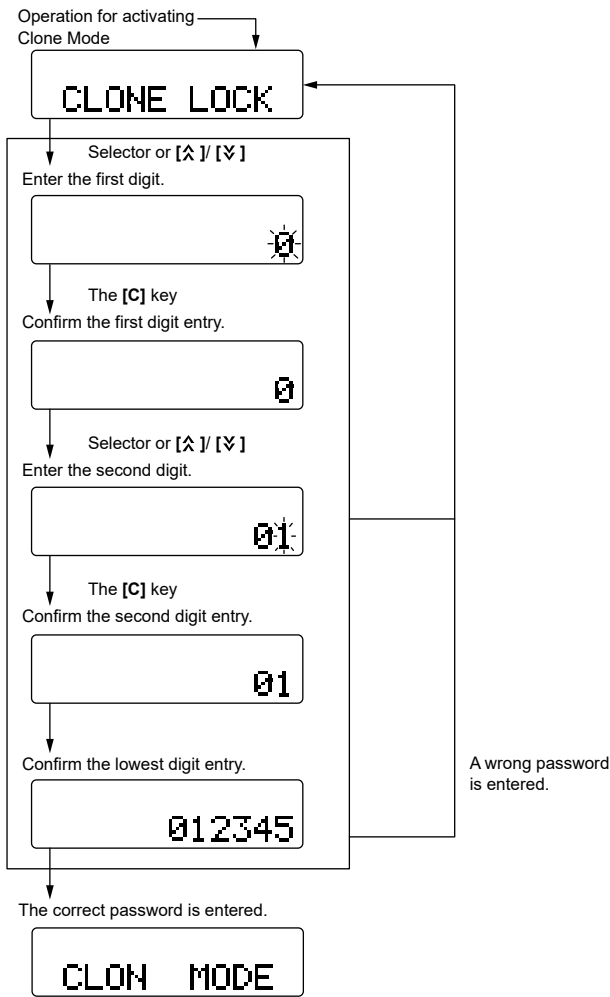

Figure 5-2 Configuring the Clone Operation using the Read Authorization Password

6 EMBEDDED MESSAGE FUNCTION

This function allows you to embed a text message (combination of alphabets and numerals) in the transceiver.

- Reading the configuration data from the Transceiver (Refer to FPRG 7.1 Read Data from the Transceiver.)

6.1 Embedded Message

This function allows you to store a maximum of 64 characters in the transceiver.

You can store the transceiver's identification information, such as its serial number and program file name.

You can configure and store messages to the transceiver using KPG-89D. The message, which is written in the transceiver, is stored as a part of the configuration data.

You can read the stored messages from the transceiver using KPG-89D.

■ Configuration using KPG-89D

- Configuring the Embedded Message (Refer to FPRG 6.18 Embedded Message.)
- Writing the configuration data to the transceiver (Refer to FPRG 7.2 Write Data to the Transceiver).
- Reading the configuration data from the transceiver (Refer to FPRG 7.1 Read Data from the Transceiver).

6.2 Embedded Message with Password

This function allows you to store a maximum of 64 characters in the transceiver with a password.

You can store the transceiver's identification information, such as its Serial Number and Configuration file name, with the password.

You can write messages and password to the transceiver using KPG-89D. When writing a message with the Embedded Message w/Password function, you can store the message as a separate data from the configuration data.

You must enter the correct password to write a message. The message is not written to the transceiver unless the correct password is entered.

You can read the stored messages from the transceiver using KPG-89D.

■ Configuration using KPG-89D

- Configuring the Embedded Message (Refer to FPRG 6.19 Embedded Message with Password.)
- Writing the configuration data to the Transceiver (Refer to FPRG 7.2 Write Data to the Transceiver.)

7 COMMUNICATION PORT

The TK-2180/ 3180 has 2 external communication ports to which you can assign separate functions. The TK-7180/ 8180 has 3 external communication ports to which you can assign separate functions.

7.1 COM Port

The TK-2180/ 3180 has 2 communication ports.

COM0 (Universal), COM 1 (Universal/26pin connector)

The TK-7180/ 8180 has 3 communication ports.

COM0 (Mic Jack), COM 1 (DB-25/26pin connector), COM 2 (DB-25)

The transceiver has following communication ports.

- COM 0 is assigned to the Microphone jack on the front panel.
- COM 1 is assigned to the DB-25/Option 26pin connector on the back panel.
- COM 2 is assigned to the DB-25pin connector on the back panel.

You can assign the following functions to each communication port using KPG-89D.

Note: You cannot assign the GPS function to the Com 0 port.

Table 7-1 Available Functions (TK-2180/ 3180)

Function	COM port	
	COM 0	COM 1
None	This port can be operated as the KPG-89D communication port.	Disabled
Data	This port can be operated as the KPG-89D/FleetSync communication port.	
Data + GPS Data Output	This port can be operated as the KPG-89D/FleetSync communication port. This port sends the received GPS data.	

Table 7-2 Available Combinations of COM port and Available Functions (TK-2180/ 3180)

Combination	COM port	Yes: Assigned function -: Available function No: Unavailable function	
		None	Data
1	COM 0	Yes	-
	COM 1	Yes	-
2	COM 0	Yes	No
	COM 1	No	Yes
3	COM 0	No	Yes
	COM 1	No	Yes

Table 7-3 Available Functions (TK-7180/ 8180)

Function	Communication port		
	COM 0	COM 1	COM 2
None	This port can be operated as the KPG-89D COM port.	Disabled.	
Data	This port can be operated as the KPG-89D/FleetSync COM port.		
GPS	-	This port can be operated as the COM port of the GPS receiver unit.	
Data + GPS Data Output	This port can be operated as the KPG-89D/FleetSync COM port. This port sends the received GPS data.		

Table 7-4 Available Combinations of COM port and Available Functions (TK-7180/ 8180)

Combination	COM port	Yes: Assigned function -: Available function No: Unavailable function			
		None	Data	GPS	Data + GPS
1	COM 0	Yes	-	-	-
	COM 1	Yes	-	-	-
	COM 2	Yes	-	-	-
2	COM 0	-	Yes	-	-
	COM 1	Yes	No	-	No
	COM 2	Yes	No	-	No
3	COM 0	-	Yes	-	No
	COM 1	Yes	No	-	No
	COM 2	-	No	Yes	No
4	COM 0	-	Yes	-	No
	COM 1	Yes	No	No	No
	COM 2	-	No	Yes	No
5	COM 0	-	-	-	Yes
	COM 1	Yes	No	No	No
	COM 2	Yes	No	No	No
6	COM 0	Yes	No	-	No
	COM 1	-	Yes	-	-
	COM 2	Yes	No	-	No
7	COM 0	Yes	No	-	No
	COM 1	-	Yes	No	No
	COM 2	-	No	Yes	No
8	COM 0	Yes	-	-	No
	COM 1	-	-	Yes	-
	COM 2	Yes	-	No	No

Combi- nation	COM port	Yes: Assigned function -: Available function No: Unavailable function			
		None	Data	GPS	Data + GPS
9	COM 0	Yes	No		No
	COM 1	-	No	Yes	No
	COM 2	-	No	No	No
10	COM 0	Yes	No		No
	COM 1	-	-	-	Yes
	COM 2	Yes	No	No	No
11	COM 0	Yes	No		No
	COM 1	Yes	No	-	No
	COM 2	-	Yes	-	-
12	COM 0	Yes	No		No
	COM 1	-	No	Yes	No
	COM 2	No	Yes	No	No
13	COM 0	Yes	-		No
	COM 1	Yes	-	No	No
	COM 2	-	-	Yes	-
14	COM 0	Yes	No		No
	COM 1	Yes	No	No	No
	COM 2	-	-	-	Yes

■ Configuration using KPG-89D

- Configuring the COM 0 (Refer to FPRG 6.7.3 Common-Page 3 tab - COM 0.)
- Configuring the COM 1 (Refer to FPRG 6.7.3 Common-Page 3 tab - COM 1.)
- Configuring the COM 2 (Refer to FPRG 6.7.3 Common-Page 3 tab - COM 2.)

8 IGNITION SENSE

This function allows you to turn the transceiver ON/OFF using the status of the Ignition Sense terminal. The Ignition Sense terminal will be High when the engine is running and it will be Low when the engine is not running.

When the Ignition Sense terminal is high, the transceiver does not activate the Horn Alert regardless of the Ignition Sense configuration. (Refer to 9 Horn Alert.)

You can enable/disable this function using KPG-89D.

Note: You must prepare the KTC-46 Ignition Sense Cable to use this function.

■ Configuration using KPG-89D

- Configuring the Mic Sense function (Refer to FPRG 6.7.1 Common-Page 1 tab - Ignition Sense.)

8.1 Using the Ignition Sense Terminal

The operation of the Ignition Sense terminal varies depending on the Ignition Sense Type.

You can configure the Ignition Sense Type using KPG-89D.

■ Configuration using KPG-89D

- Configuring the Ignition Sense Type (Refer to FPRG 6.7.1 Common-Page 1 tab - Ignition Sense Type.)

8.1.1 Turning the Transceiver ON/OFF with the Ignition Sense Function

The transceiver is automatically turned ON/OFF according to the Ignition Sense terminal status by selecting "Ignition Only".

The transceiver automatically is turned ON when the Ignition Sense terminal becomes high and automatically turned OFF when the terminal becomes low. In this case, you cannot turn the transceiver ON/OFF using the **Power** switch.

8.1.2 Turning the Transceiver ON/OFF with the Ignition Sense Function and the Power Switch

You can turn the transceiver ON/OFF using the status of the Ignition Sense terminal and by pressing the **Power** switch when selecting "Ignition & SW".

This function allows you to turn the transceiver OFF by pressing the **Power** switch even if the engine of the car is running (Ignition Sense is High). In this case, the status of the **Power** switch is not stored.

The transceiver is automatically turned ON when the Ignition Sense terminal becomes High.

8.2 Timed Power-off

This function allows you to keep turning the transceiver OFF for the configured duration while the engine of the car is not running (Ignition Sense Terminal is Low).

This function is convenient to perform communications after the engine is stopped.

You can configure the duration from the time when the Ignition Sense terminal becomes Low to the time when the transceiver is automatically turned OFF.

The Timed Power-off Pre-alert tone sounds in the following way when the Warning Tone is configured to "OFF".

- 1 minute before the transceiver is turned OFF:
- 10 seconds before the transceiver is turned OFF:
- 2 seconds before the transceiver is turned OFF:

Note:

- ◆ The Timed Power-off does not activate when the Ignition Sense function is disabled.
- ◆ When the Ignition Sense terminal becomes High, the Timed Power-off is reset and the transceiver returns to the normal operation.
- ◆ The Timed Power-off function is disabled when turning the transceiver ON by pressing and holding the **Power** switch while the Ignition Sense function is configured to "Ignition & SW".
- ◆ The Timed Power-off function is reset when turning the transceiver ON/OFF by pressing the **Power** switch during the Timed Power-off duration while the Ignition Sense function is configured to "Ignition & SW".

■ Configuration using KPG-89D

- Configuring the Timed Power-off duration (Refer to FPRG 6.7.1 Common-Page 1 tab - Timed Power-off.)

9 HORN ALERT

The TK-7180/ 8180 has a Horn Alert output terminal that will function with the following features.

- Individual call using optional signaling (DTMF, 2-tone)
- GID/Fix ID in LTR Trunking System
- FleetSync Status No. 89

With this function enabled, a user can be alerted that the transceiver has received a call since the horn will sound and the headlights of the car will turn On. Therefore, the user will notice that the transceiver has received a call even if he/she is away from the transceiver.

Horn Alert is not necessary while driving the vehicle, therefore you can configure the function to activate using the Ignition terminal status. The following Horn Alert terminal operations can be used when the Ignition Sense terminal is connected to the Ignition terminal. (Refer to 8 Ignition Sense.)

Table 9-1 Horn Alert Operation

Ignition	Ignition Sense	Power	Horn Alert
On	Ignition only	ON	
	Ignition & SW	Power On > ON	
		Power Off > OFF	
Off	Ignition only	OFF	
	Ignition & SW	Power On > ON	Active
		Power Off > OFF	
On	Disable	Power On > On	
		Power Off > Off	
Off	Disable	Power On > ON	Active
		Power Off > OFF	

You can use the Horn Alert function by installing the KAP-2 (Optional) to the CN428 connector.

9.1 Switching the Horn Alert ON/OFF

You can enable/disable the Horn Alert function by switching the PF Horn Alert function.

■ Transceiver operation

● Enabling the Horn Alert Function

1. Press the **PF Horn Alert** key when the Horn Alert function is disabled.

“” The Horn Alert function is enabled and the icon lights.



TK-7180/ 8180

● Disabling the Horn Alert Function

1. Press the **PF Horn Alert** key when the Horn Alert function is enabled.

The Horn Alert function is disabled and the “” icon disappears.



TK-7180/ 8180

■ Configuration using KPG-89D

- Assigning functions to the **PF** keys (Refer to FPRG 6.8 Key Assignment.)

9.2 Horn Alert Operation using Option Signaling and LTR ID

Activation conditions of the Horn Alert function are different between the Conventional Group and a Trunking system.

9.2.1 Conventional Group

The Horn Alert function is enabled when the **PF Horn Alert** key is pressed and the “” icon appears. The Horn Alert function is enabled even if the Optional Signaling is not configured to the channel.

When the Horn Alert function is enabled, the HOR terminal is activated when receiving an individual call. This terminal operates according to the Horn Alert Logic Signal configuration. (Refer to 9.4.1 Horn Alert Logic Signal.)

One of the following conditions must be met to activate the Horn Alert in Conventional Group Mode.

9 HORN ALERT

Table 9-2 Conditions for the Horn Alert to be activated in a Conventional Group

Signaling Configuration			Conditions to Activate the Horn Alert Function
Audio control configuration	QT/DQT Decode configuration	Optional Signaling configuration	
QT/DQT or Optional signaling	None	None	-
	None	Other than none	Carrier + Optional signaling match
	Other than none	None	-
	Other than none	Other than None	Carrier + Optional signaling match
QT/DQT and Optional signaling	None	None	-
	None	Other than none	Carrier + Optional signaling match
	Other than none	None	-
	Other than none	Other than none	Carrier + QT/ DQT match + Optional signaling match

Table 9-3 Conditions to Activate the Horn Alert Function in a Trunking System

Signaling Configuration			Conditions to Activate the Horn Alert Function
Horn Alert configuration	Decode ID Configuration	Optional Signaling Configuration	
Disabled	None	None	-
	None	Other than None	-
	Other than None	None	-
	Other than None	Other than None	-
	Other than None	Other than None	-
Enabled	None	None	-
	None	Other than None	-
	Other than None	None	Decode ID
	Other than None	Other than None	Decode ID + Optional Signaling Match

9.2.2 Trunking System

In a Trunking system, you can configure the Horn Alert function to each Group ID. Conditions to activate the Horn Alert function are different between when the Horn Alert function is configured to the Group ID and when the Horn Alert function is not configured to the ID.

When the Horn Alert function is enabled, the HOR terminal is activated when receiving an individual call. This terminal operates according to the Horn Alert logic signal configuration.

(Refer to 9.4.1 Horn Alert Logic Signal.)

The transceiver performs the pulse operation when receiving the Fixed ID. (Refer to 17.1.17 Fix ID.)

- **When the PF Horn Alert Key is Configured:**

The Horn Alert function is enabled when the **PF Horn Alert** key is pressed when the Horn Alert function is configured to a Group ID. The icon appears when the Horn Alert function is enabled.

The Horn Alert function is not enabled even if the **PF Horn Alert** key is pressed when the Horn Alert function is not configured to a Group ID.

- **When the PF Horn Alert Keys is not Configured:**

The Horn Alert function is automatically enabled when the Horn Alert function is configured to a Group ID. The icon appears.

The Horn Alert function is not enabled when the Horn Alert function is not configured to a Group ID.

Following are the conditions to activate the Horn Alert function.

9.3 Horn Alert Operation During FleetSync Call

The HOR terminal becomes active when receiving the Status No. 89 in FleetSync. This function is activated regardless of a Conventional Group and the Trunking System configurations.

9.4 Configuring Horn Alert

You can configure the following items that are linked to the Horn Alert function using KPG-89D.

- Horn Alert Logic Signal
- Off-hook Horn Alert
- Horn Alert Mode

9.4.1 Horn Alert Logic Signal

This function allows you to configure the type of the HOR terminal operation when the Horn Alert function is activated.

You can configure the Horn Alert Logic Signal using KPG-89D. The following HOR terminal operation is available.

Table 9-4 Horn Alert Logic Signal Operation

Configuration	Description
Pulse	The HOR terminal becomes active for 3 times every 500 ms. The HOR terminal activates (1s Active, 500 ms, and Inactive 1 s Active) when receiving the Fix ID.
Continuous	When the function is configured for "Until Reset", the Horn Alert terminal remains active until the Option Signaling match status resets. When the duration is configured between 1 s - 30 s, the HOR terminal remains active until the configured duration expires.

Note:

- ◆ The HOR terminal is not disabled even when the match status of the DTMF/2-tone resets while the Horn Alert Logic Signal time is longer than the Auto Reset Timer of DTMF or 2-tone. The Horn Alert Port is disabled when the duration configured for the Horn Alert Logic Signal expires.
- ◆ The Horn Alert operation pauses when pressing the **PF Horn Alert** key while the Horn Alert function is active. In this case, the Horn Alert function is also disabled.
- ◆ The Horn Alert operation pauses when changing the Zone-CH/GID while the Horn Alert function is active. The Horn Alert the Horn Alert function is not disabled.
- ◆ When selecting "Until Reset" in the Horn Alert Logic Signal function, the Horn Alert function is disabled with the following conditions while the Horn Alert function is operating with the match status of the ID in Trunking System.
 - Press the **PF Horn Alert** key.
 - Changing the Mic Hook status
 - Changing the Zone-CH/GID

■ Configuration using KPG-89D

- Configuring the Horn Alert Logic Signal (Refer to FPRG 6.7.1 Common-Page 1 tab - Horn Alert Logic Signal.)

9.4.2 Off-hook Horn Alert

This function allows you to configure the Horn Alert function to operate in conjunction with the Mic hook status.

You can configure the Off-hook Horn Alert function using KPG-89D. The following conditions must be configured to activate the Horn Alert function.

■ DTMF/2-tone

Table 9-5 Conditions to Activate the Horn Alert Function with DTMF/2-tone

Off-hook Horn Alert configuration	Horn Alert configuration	Status of the hook (On/Off)	Horn Alert function
Off	Off	Off	Disabled
		On	Disabled
	On	Off	Disabled
		On	Enabled
On	Off	Off	Disabled
		On	Disabled
	On	Off	Enabled
		On	Enabled

■ FleetSync

Table 9-6 Conditions to Activate the Horn Alert Function with FleetSync
(Receiving Status No. 89)

Off-hook Horn Alert Configuration	Horn Alert Configuration	Status of the Hook (On/Off)	Horn Alert Function
Off	Off	Off	Disabled
		On	Enabled
	On	Off	Disabled
		On	Enabled
On	Off	Off	Enabled
		On	
	On	Off	
		On	

■ Configuration using KPG-89D

- Configuring the Off-hook Horn Alert function (Refer to FPRG 6.7.1 Common-Page 1 tab - Off-hook Horn Alert.)

9.4.3 Horn Alert Mode

This function allows you to configure the control method to enable/disable the Horn Alert function.

You can configure Horn Alert Mode using KPG-89D. The following Horn Alert modes are available.

Table 9-7 Horn Alert Mode Type

Configuration	Description
Current	It resets the Horn Alert stand-by status when the transceiver is turned OFF. The Horn Alert function is disabled when the transceiver is turned ON.
Status Memory	The stand-by status of the Horn Alert function is stored. Turn the transceiver OFF while the Horn Alert function is in stand-by mode. The Horn Alert function activates in stand-by mode when turning the transceiver ON again.
Startup	The transceiver activates the Horn Alert function in stand-by mode.

■ Configuration using KPG-89D

- Configuring Horn Alert mode (Refer to FPRG 6.7.1 Common-Page 1 tab - Horn Alert Mode.)

10 KEY ASSIGNMENT

You can assign functions to the **Selector** and the **PF** keys.

■ Configuration using KPG-89D

- Assigning functions to the **Selector** and **PF** keys (Refer to FPRG 6.8 Key Assignment.)

10.1 Available Functions

(TK-2180/ 3180 only)

You can assign functions to the **Selector** keys using KPG-89D.

You can configure these functions to the TK-2180/ 3180 only.

Table 10-1 Assigning Functions to the Selector

Function Name	Description
None	The repeater does not perform any operation. The Key-entry Error Tone sounds when the None key is pressed.
CH/GID Up/Down	Turn the Selector to increase/decrease the CH/GID in steps of 1.
Zone Up/Down	Turn the Selector to increase/decrease the Zone number in steps of 1.

10.2 Assigning Functions to the PF Keys

You can assign functions to the **PF** keys using KPG-89D.

Table 10-2 Available Functions

Function Name	Description
None	The repeater does not perform any operation. The Key-entry Error Tone sounds when the None key is pressed.
2-tone	The transceiver sends the 2-tone code configured in the 2-tone Encode List Call 2 when the key is pressed. (Refer to 21 2-tone.)
Autodial	The transceiver sends the DTMF code configured in the DTMF Autodial List when the key is pressed. (Refer to 20 DTMF.)
Autodial Programming	Press the PF Autodial Programming key to configure, change, or delete the DTMF Autodial List. (Refer to 20.4.2 Autodial Programming.)

Function Name	Description
Auto Reply Message	Press the PF Auto Reply Message key to switch the Auto Reply Message On/Off when the VGS-1 is installed to the transceiver. (Refer to 31.3 Auto Reply Message.)
Auto Telephone	Press the PF Auto Telephone key to search the RIC repeater and automatically connect to the telephone. (Refer to 17.1.14 Auto Telephone Search.)
AUX	The AUX Output terminal becomes active/inactive when the PF AUX key is pressed. A user can control the external device connected to the AUX port since the port output varies in conjunction with the AUX key. This function is available only for the TK-2180/ 3180.
AUX A	The AUX A Output terminal becomes active/inactive when the PF AUX A key is pressed. A user can control the external device connected to the AUX A port since the port output varies in conjunction with the AUX A key. This function is available only for the TK-7180/ 8180.
AUX B	The AUX B Output terminal becomes active/inactive when the PF AUX B key is pressed. The user can control the external device connected to the AUX B port since the port output varies in conjunction with the AUX B key. This function is only available for the TK-7180/ 8180.
Call 1/2/3/4/5/6	You can send FleetSync Status, DTMF code, and 2-tone code by pressing one of PF Call 1 - Call 6 keys. (Refer to 1.11 Call Key.)
CH/GID Down	Press the PF CH/GID Down key to decrease the CH/GID in steps of 1. Press and hold this key for more than 1 second to decrease the CH/GID number in steps of 1 every 200 ms (Refer to 2.5 Changing the CH/GID.)
CH/GID Up	Press the PF CH/GID UP key to increase the CH/GID in steps of 1. Press and hold this key for more than one second to increase the CH/GID number in steps of 1 every 200 ms. (Refer to 2.5 Changing the CH/GID.)
Channel Entry	You can directly specify the channel number using the Keypad of the TK-2180/ 3180 or the microphone of the TK-7180/ 8180. (Refer to 2.6 Channel Entry.)
CH/GID Recall	Press the PF CH/GID Recall key to move to the Last Called Zone-CH/GID during scan. (Refer to 23.7.16 CH/GID Recall.)
Clock	Press the PF Clock key to display the clock. (Refer to 30 CLOCK.)
Direct CH/GID 1 - 5	Press the PF Direct CH/GID 1 - 5 key to move to the registered CH/GID. (Refer to 2.8 Direct CH/GID.)

Function Name	Description
Display Character	Press the PF Display Character key to switch the Main Display to the CH/GID Name display or the Zone-CH/GID Number display. (Refer to 3.6.5 Display Character.)
Emergency	Press the PF Emergency key to enter Emergency Mode. (Refer to 24 Emergency Mode.)
Fixed Volume	Press the PF Fixed Volume key to adjust the tone level. The level changes from High - Low - Off. (Refer to 4 Sound.)
Function	Press the PF key to wait for the Function to operate. The Function status is reset if no key is pressed while the Mode Reset Timer is active. (Refer to 26 Function Port.)
Home CH/GID	Press the PF Home CH/GID key to move to the registered CH/GID. (Refer to 2.7 Home CH/GID.)
Horn Alert	Press the PF Horn Alert key to enable the Horn Alert function. (Refer to 9 Horn Alert.)
Key Lock	Press the PF Key Lock key to enable the Key Lock function. This function is available only for the TK-2180/ 3180. (Refer to 1.9 Key Lock.)
Lamp	Press the PF Backlight key to light the backlight. This function is available only for the TK-2180/ 3180. (Refer to 3.3.1 Backlight.)
LCD Brightness	Press the PF LCD Brightness key to adjust the LCD Brightness. This function is available only for the TK-7180/ 8180. (Refer to 3.3.2 LCD Brightness.)
Low Transmit Power	Press the PF Low Transmit Power key to change the output power of the transceiver. <ul style="list-style-type: none"> • Low Transmit Power • High Transmit Power
Monitor	Press the PF Monitor key to reset the QT/DQT and unmute with the Carrier. (Refer to 18.6 Monitor.)
Monitor Momentary	Press the PF Monitor Momentary key to reset the QT/DQT and unmute with the Carrier. (Refer to 18.6 Monitor.)
OST	Press the PF OST key to manually select the QT Encode/Decode pair. (Refer to 19 OST.)
Playback	Press the PF Playback key to record or play when the VGS-1 is installed to the transceiver. (Refer to 31 VGS.)
Public Address	Press the PF Public Address key to enable/disable the Public Address function. (Refer to 4.12 Public Address.)
Transceiver Password	Press the PF Transceiver Password key to limit the functions of the transceiver and make the transceiver enter Password Entry Mode. (Refer to 5.1 Transceiver Password.)

Function Name	Description
Scan	Press the PF Scan key to start/stop scanning. (Refer to 23 Scan.)
Scan Delete/Add	Press the PF Scan Delete/Add key to add the Zone-CH/GID to the Scan List. (Refer to 23.7.1 Scan Del/Add.)
Scrambler	Press the PF Scrambler key to enable/disable the Voice Scrambler code. You can configure the level between 1 and 16. (Refer to 29 Voice Scrambler.)
SelCall	Press the PF SelCall key to directly enter the Fleet/ID and make a Selective Call. (Refer to 22.2 Selective Call Function.)
SelCall + Status	Press the PF SelCall + Status key to directly enter the Fleet/ID and send the Status Message. (Refer to 22.2 Selective Call Function.)
Send the GPS Data	Press the PF Send the GPS Data key to manually send the GPS data received via COM port of the transceiver from the optional GPS unit to the Base station. (Refer to 22.6 GPS Function.)
Speaker Attenuation	Press the PF Speaker Attenuation key to attenuate the sound of the speaker microphone. (Refer to 4.11 Speaker Attenuation.)
Squelch Level	Press the PF Squelch Level key to change the Squelch Level. (Refer to 18.7 Squelch.)
Squelch Off	Press the PF Squelch Off key to unmute. (Refer to 18.7 Squelch.)
Squelch Off Momentary	Press the PF Squelch Off Momentary key to unmute. (Refer to 18.7 Squelch.)
Status	Press the PF Status key to directly enter the Status number and send the Status Message. (Refer to 22.3 Status Message Function.)
Talk Around	Press the PF Talk Around key to enable/disable the Talk Around function. (Refer to 13 Talk Around.)
Telephone Discount	Press the PF Telephone Discount key to disconnect the phone line. (Refer to 17.4 Telephone Interconnect.)
Volume Down	Press the PF Volume Down key to decrease the Volume level in steps of 1. Press and hold this key to decrease the Volume level decreases in steps of 1 every 100 ms. This function is available only for TK-7180/ 8180. (Refer to 2.2 Adjusting the Volume.)
Volume Up	Press the PF Volume Up key to increase the Volume level in steps of 1. Press and hold this key for more than 1 second to increase the Volume level in steps of 1 every 100 ms. This function is available only for TK-7180/ 8180. (Refer to 2.2 Adjusting the Volume.)

Function Name	Description
VOX	Press the PF VOX key to enable/disable the VOX function. You can also configure the VOX Gain Level. This function is available only for TK-2180/3180. (Refer to 28 VOX.)
Zone Down	Press the PF Zone Down key to decrease the Zone number in steps of 1. Press and hold this key for more than 1 second to decrease the Zone number in steps of 1 every 200 ms. (Refer to 2.4 Changing the Zone.)
Zone Up	Press the PF Zone Up key to increase the Zone number in steps of 1. Press and hold this key for more than 1 second to increase the Zone number in steps of 1 every 200 ms. (Refer to 2.4 Changing the Zone.)

11 TIME-OUT TIMER

This function restricts the continuous transmission time (TOT).

This function prevents the user from occupying a repeater frequency for a long period of time when the repeater is shared with other users. The transceiver stops transmitting when it is continuously transmitting longer than the configured time.

You can configure the Time-out Timer to each Zone. The operation of this function varies between a Conventional Group and a Trunking System.

11.1 Conventional Group

You can configure the following items in a Conventional Group.

- Time-out Timer
- TOT Pre-alert
- TOT Rekey Time
- TOT Reset Time

11.1.1 Time-out Timer

This function restricts the continuous transmission time (TOT).

You can configure this period using KPG-89D.

Note: This function does not operate in Emergency Mode.

■ Configuration using KPG-89D

- Configuring the continuous transmission time (Refer to FPRG 6.2.7 Time-out Timer (TOT).)

11.1.2 TOT Pre-alert

This function allows the transceiver to notify a user that the transmission timer is about to expire. The transceiver emits the TOT Pre-alert tone when the timer expires.

You can configure the timing to emit the TOT Pre-alert tone using KPG-89D.

Note: The TOT Pre-alert tone is only emitted while transmitting. This tone is not emitted while the transmission pauses within the TOT Reset Time. (Refer to 11.1.4 TOT Reset Time.)

■ Configuration using KPG-89D

- Configuring the TOT Pre-alert Tone (Refer to FPRG 6.2.8 TOT Pre-alert.)

11.1.3 TOT Rekey Time

The function is used to configure the time from when the Time-out Timer starts operating to the time when the transceiver starts transmission again. This function is used to temporarily restrict the transmission when a user occupies the repeater or the frequency for a long time.

You can configure the TOT Rekey Time using KPG-89D.

Note:

- ◆ TOT Rekey Time is disabled when the transceiver is turned ON or OFF during the TOT Rekey Time.
- ◆ The TOT Rekey Time is reset when the following key is pressed.
 - PF Zone Up key
 - PF Zone Down key
 - PF Zone Up/Down key
 - PF CH/GID Up key
 - PF CH/GID Down key
 - PF CH/GID Up/Down key
 - PF Home CH/GID key
 - PF Direct CH/GID - Direct CH/GID 6 key

■ Configuration using KPG-89D

- Configuring the TOT Rekey Time (Refer to FPRG 6.2.9 TOT Rekey Time.)

11.1.4 TOT Reset Time

The TOT (Time-out Timer) Reset Time is the period to reset the Time-out Timer.

When a user re-transmits within the TOT Reset Time, it is counted as a continuous transmission. This function prevents a user from occupying a repeater or frequency for a long time with transmitting intermittently.

You can configure the TOT Reset Time using KPG-89D.

Note: The TOT Rekey Time is reset when the following key is pressed.

- PF Zone Up key
- PF Zone Down key
- PF Zone Up/Down key
- PF CH/GID Up key
- PF CH/GID Down key
- PF CH/GID Up/Down key
- PF Home CH/GID key
- PF Direct CH/GID - Direct CH/GID 6 key

■ Configuration using KPG-89D

- Configuring the TOT Reset Time (Refer to FPRG 6.2.10 TOT Reset Time.)

11.2 Trunking System

You can configure the following items in a Trunking system.

- Time-out Timer (Dispatch)
- Time-out Timer (Telephone)

11.2.1 Time-out Timer (Dispatch)

The Time-out Timer (Dispatch) restricts the continuous transmission when a user communicates with the Dispatcher ID.

The transceiver pauses the transmission and emits the Warning Tone when attempting to transmit after the configured Time-out Timer (Dispatch) expires. The transceiver emits the Warning Tone until the **PTT** switch is released.

You can configure the Time-out Timer (Dispatch) using KPG-89D.

Note:

- ◆ The transceiver returns to normal receiving mode after the EOT expires if it pauses the transmission in FleetSync, etc.
- ◆ This function does not work in Emergency Mode.

■ Configuration using KPG-89D

- Configuring the Time-out Timer (Dispatch) (Refer to FPRG 6.5.8 Time-out Timer (Dispatch).)

11.2.2 Time-out Timer (Telephone)

The Time-out Timer (Telephone) restricts the continuous transmission when a user communicates with the Telephone ID.

The transceiver pauses the transmission and emits the Warning Tone when attempting to transmit after the configured Time-out Timer (Dispatch) expires. The transceiver emits the Warning Tone until the **PTT** switch is released.

You can configure the Time-out Timer (Telephone) using KPG-89D.

Note:

- ◆ The transceiver returns to normal receiving mode after the EOT expires if it pauses the transmission in FleetSync, etc.
- ◆ This function does not work in Emergency Mode.

■ Configuration using KPG-89D

- Configuring the Time-out Timer (Telephone) (Refer to FPRG 6.5.9 Time-out Timer (Telephone).)

12 BUSY CHANNEL LOCKOUT

12.1 Busy Channel Lockout

This function automatically prevents a transmission so as not to interfere other communications.

If a user transmits on a channel while other groups are using that channel, the user may interfere with communications. This function prevents such interference.

The “BUSY” icon appears on the main display when the **PTT** switch is pressed while this function is enabled. The transceiver emits a Warning Tone and does not transmit. The transceiver emits the Warning Tone until the **PTT** switch is released.

You can configure the Busy Channel Lockout function for each channel using the KPG-89D. The following table shows the conditions to inhibit transmission with the Busy Channel Lockout function.

Table 12-1 Conditions to Inhibit Transmission with the Busy Channel Lockout

Busy Channel Lockout	Condition
QT/DQT Tone	The transceiver does not transmit when the received QT/DQT code does not match the QT/DQT code configured to the Channel.
Optional Signaling	The transceiver does not transmit until the Option Signaling matches.
Carrier Only	The transceiver does not transmit while receiving a Carrier. However, the transceiver transmits even if a Carrier exits when the Monitor function is enabled.

Note:

- ◆ This function is available only in Conventional Group. In a Trunking System, a user can use the TA Busy Channel Lockout function. (Refer to 13.2.1 TA Busy Channel Lockout.)
- ◆ This function does not work in Emergency Mode.

■ Configuration using KPG-89D

- Configuring the Busy Channel Lockout function (Refer to FPRG 6.3.11 Busy Channel Lockout.)

12.2 BCL Override

This function allows the transmission of data while the transceiver channel is busy, even if the transceiver cannot normally transmit on a busy channel. This is used for high priority communications.

You can enable/disable this function using KPG-89D.

Note: This function is available only in Conventional Group.

■ Transceiver operation

1. Press the **PTT** switch while the transmission is restricted with the Busy Channel Lockout function.
2. Release the **PTT** switch, then press the switch again within 500 ms.

The Busy Channel Lockout function is disabled and you can transmit.

■ Configuration using KPG-89D

- Configuring the BCL Override (Refer to FPRG 6.2.11 BCL Override.)

13 TALK AROUND

This function allows you to communicate to another transceiver without using a repeater.

13.1 Conventional Group

This function allows you to transmit on the receive frequency and Decode Signaling (QT/DQT) configured for the selected channel.

■ Transceiver operation

● Enabling the Talk Around Function

1. Press the **PF Talk Around** key if the function is disabled.

The “” icon appears and the Talk Around function is enabled.

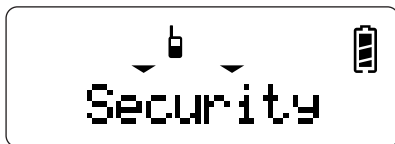

TK-2180/ 3180



TK-7180/ 8180

● Disabling the Talk Around Function

1. Press the **PF Talk Around** key if the function is enabled.

The “” icon disappears and the Talk Around function is disabled.

Note:

- ◆ The Talk Around function is disabled when changing the Zone-CH/GID when the Talk Around function is enabled.
- ◆ The Talk Around function is disabled when moving to the data channel using the DTC or the Data PTT while the Talk Around function is enabled on the Voice Channel. The Talk Around becomes active when the transceiver moves to the Voice channel.
- ◆ This function does not work in Emergency Mode.

■ Configuration using KPG-89D

- Assigning functions to the **PF** keys (Refer to FPRG 6.8 Key Assignment.)

13.2 Trunking System

When the Talk Around function is enabled, you can transmit on the receive frequency and Encode ID of the Home Repeater of the selected Zone.

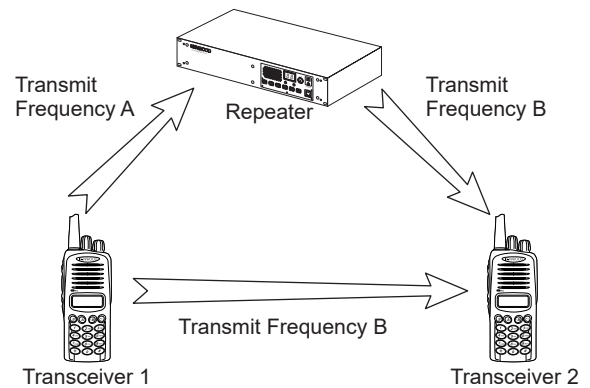



Figure 13-1 Talk Around

You can enable/disable this function for each Group ID using KPG-89D.

The “” icon appears on the Group ID that Talk Around is enabled on. You cannot disable the Talk Around function using the **PF Talk Around** key.

You can enable/disable the Talk Around function on the Group ID that the Talk Around function is not enabled using the **PF Talk Around** key. You can enable/disable the Talk Around function for each Zone. (Refer to 13.2.2 TA Key.)

Note:

- ◆ The Talk Around function will be automatically disabled when the Zone/GID is changed if the Talk Around function is enabled.
- ◆ You can configure to enable/disable the **PF Talk Around** key for each Zone.

■ Transceiver operation

● GID that the Talk Around Function is Enabled:

1. Select the GID that the Talk Around function is enabled on.

The “” icon appears and the Talk Around function is enabled.

● GID that the Talk Around Function is Disabled:

1. Press the **PF Talk Around** key.

The “” icon appears and the Talk Around function is enabled.

2. Press the **PF Talk Around** key.

The “” icon disappears and the Talk Around function is disabled.

■ Configuration using KPG-89D

- Configuring the Talk Around function (Refer to FPRG 6.6.13 Talk Around.)
- Assigning functions to the **PF** keys (Refer to FPRG 6.8 Key Assignment.)

■ Configuration using KPG-89D

- Configuring the **TA** key (Refer to FPRG 6.5.17 TA Key.)

13.2.1 TA Busy Channel Lockout

This function automatically restricts the transmission so as not to interfere with other communications.

The transceiver can communicate using the Talk Around function when the Home Repeater is out of transceiver coverage. If a user transmits on a channel while other groups are using that channel, the user may interfere with their communications. This function prevents such interference.

The “BUSY” icon appears on the main display if the **PTT** switch is pressed while this function is enabled. In this case, the transceiver emits the Warning Tone and does not transmit. The transceiver emits the Warning Tone until the **PTT** switch is released.

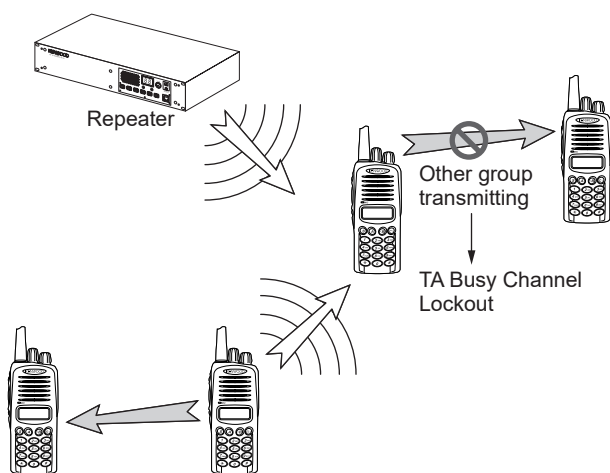

Figure 13-2 TA Busy Channel Lockout

You can enable/disable this function using KPG-89D.

■ Configuration using KPG-89D

- Configuring the TA Busy Channel Lockout function (Refer to FPRG 6.5.16 TA Busy Channel Lockout.)

13.2.2 TA Key

This function allows you to enable/disable the **PF Talk Around** key operation.

Disable the **TA** key so as not to allow the user to use the Talk Around function.

You can enable/disable the **TA** key operation using the KPG-89D.

This is the identification code transmitted when the **PTT** switch is pressed and/or released.

By using this ID, the base station (dispatcher) can identify the caller without asking for the caller's name.

You can configure the following items to PTT ID using KPG-89D.

- PTT ID Type
- PTT ID (CH/GID Information)
- Restricted ID in TA

14.1 PTT ID Type

You can select the PTT ID type. Select DTMF or FleetSync as the PTT ID format.

You can select DTMF or FleetSync using KPG-89D.

You can configure the Beginning of Transmit and the End of Transmit when the DTMF is selected. (Refer to [14.1.1 Beginning of Transmit](#), [14.1.2 End of Transmit](#).)

You can configure the Fleet (Own) and the ID (Own) when selecting FleetSync. (Refer to [22.9.1 Own Fleet/ID](#).)

■ Configuration using KPG-89D

- Configuring the PTT ID Type (Refer to FPRG 6.7.3 Common-Page 3 tab - PTT ID Type.)

14.1.1 Beginning of Transmit

You can configure the ID to be sent at the beginning of transmit when the DTMF is selected.

You can configure the ID to be sent as the BOT using KPG-89D. No ID will be transmitted if you do not configure the BOT ID.

■ Configuration using KPG-89D

- Configuring the Beginning of Transmit (Refer to FPRG 6.7.3 Common-Page 3 tab - Beginning of Transmit.)

14.1.2 End of Transmit

You can configure the ID to be sent at the beginning of transmit when selecting DTMF.

You can configure the ID to be sent as the EOT using KPG-89D. No ID will be transmitted if you do not configure the content of the ID.

■ Configuration using KPG-89D

- Configuring the End of Transmit (Refer to FPRG 6.7.3 Common-Page 3 tab - End of Transmit.)

14.2 PTT ID (CH/GID Information)

PTT ID (CH/GID Information) allows you to select the timing to send the PTT ID.

You can enable/disable the PTT ID for each CH/GID using KPG-89D. The following configuration is available.

Table 14-1 Timing to Transmit the PTT ID
(When the PTT ID Type is DTMF/ANI board.)

PTT ID	Timing to Transmit the PTT ID
Off	No PTT ID is transmitted.
BOT	This PTT ID is transmitted each time the PTT switch is pressed.
EOT	This PTT ID is transmitted each time the PTT switch is released.
Both	This PTT ID is transmitted when the PTT switch is pressed and released.

Table 14-2 Timing To Transmit the PTT ID
(When the PTT ID Type is FleetSync.)

PTT ID	Timing To Transmit the PTT ID
Off	No PTT ID is transmitted.
BOT	Fleet (Own) and ID (Own) are transmitted as the PTT ID when the PTT switch or the PF Ext. PTT (Voice) port is pressed.
EOT	Fleet (Own) and ID (Own) are transmitted as the PTT ID when the PTT switch or the PF Ext. PTT (Voice) port is released.
Both	Fleet (Own) and ID (Own) are transmitted as the PTT ID when the PTT switch or the PF Ext. PTT (Voice) port is pressed and released.
List 1 - 100 (FleetSync only)	You can make an individual call. You can select the ID from 1 to 100 in the SelCall list. You can make a SelCall using the Fleet and the ID.

Table 14-3 Timing to Transmit the PTT ID
(When the PTT ID Type is ANI board.)

PTT ID	Timing To Transmit the PTT ID
Off	No PTT ID is transmitted.
On	This ANI code of the ANI Board is sent. The timing to transmit the PTT ID must be configured to the ANI board.

Note:

- ◆ "List 1 - 100" and "On" do not appear when selecting "DTMF" using the **PTT ID** pull-down menu.
- ◆ "On" will not appear when selecting "FleetSync" using the **PTT ID** pull-down menu.
- ◆ "BOT", "EOT", "Both", and "List 1 - 100" do not appear when selecting "ANI Board" using the **PTT ID** pull-down menu.

14 PTT ID

- ◆ You can select the ID configured in **FleetSync** window > **ID List** tab for List 1 - 100 only.

■ Configuration using KPG-89D

- Configuring the PTT ID (Conventional Group) (Refer to FPRG 6.3.12 PTT ID.)
- Configuring the PTT ID (Trunking System) (Refer to FPRG 6.6.8 PTT ID.)

14.3 Restricted ID in TA

This function disables the PTT ID transmission even when the **PTT** switch is pressed and released in the Talk Around Mode.

You can use this function when the PTT ID is not required to make a direct communication between transceivers.

You can enable/disable the Restricted ID in TA function using KPG-89D.

Note: This function is available only in Conventional Group.

■ Configuration using KPG-89D

- Configuring the Restricted ID in TA function (Refer to FPRG 6.7.4 Conventional tab - Restricted ID in TA.)

This function allows you to send the Acknowledge signal when receiving a call. The transceiver transmits the Transpond Tone when the Acknowledge is transmitted.

The dispatcher can also confirm that the transceiver is within the communication range, or outside of the communication range.

The Transpond operation varies between the Optional Signaling call and the LTR ID call.

15.1 Transpond Using the Optional Signaling

The transceiver transmits the acknowledge signal to the Dispatcher after receiving the Individual Call with 2-tone or DTMF, or DTMF Stun code.

Note:

- ◆ Transpond does not work with Group calls.
- ◆ The Transpond function is canceled when changing the channel while the transceiver is in Transpond Standby Mode.
- ◆ When the Clear to Transpond function is enabled, the Transpond is not transmitted while the channel is being used. ([Refer to 15.3.1 Clear to Transpond.](#))

15.2 Transpond Using the LTR ID

This function allows the transceiver to transmit an Acknowledge signal to the dispatcher after receiving a call with the LTR ID. The transceiver performs the Transpond function after the Transpond Delay Time expires. ([Refer to 15.4.1 Transpond Delay Time.](#))

Note:

- ◆ When the Transpond ID is received during scan, the transceiver performs the Transpond function after the Transpond Delay Timer expires. The transceiver resumes scan after the Dwell Timer expires. If the Dropout Delay Timer is shorter than the Transpond Delay Time, the transceiver performs the Transpond function after the Dropout Delay Time expires.
- ◆ The Transpond operation is canceled when changing the Zone or GID during the Transpond Delay Time.
- ◆ While the TX Inhibit function is activated, the transceiver will not Transpond. ([Refer to 17.1.19 TX Inhibit \(Block IDs\).](#))

15.3 Conventional Group

15.3.1 Clear to Transpond

This function allows you to wait for performing the Transpond function until the channel becomes available.

You can enable/disable this function using KPG-89D. You can configure this function to 2-tone and DTMF.

■ Configuration using KPG-89D

- Configuring the Clear to Transpond (2-tone) (Refer to FPRG 6.11.1 Decode tab - Clear to Transpond.)
- Configuring the Clear to Transpond (DTMF) (Refer to FPRG 6.10.2 Decode tab - Clear to Transpond.)

15.4 Trunking System

This function allows the transceiver to transmit an acknowledge signal to the dispatcher after receiving a call with the LTR ID. The transceiver performs the Transpond function after the Transpond Delay Time expires.

You can enable/disable this function for each Group ID using KPG-89D.

■ Configuration using KPG-89D

- Configuring the Transpond function (Refer to FPRG 6.6.12 Transpond.)

15.4.1 Transpond Delay Time

The Transpond Delay Time is the delay time between the time when the transceiver receives an Group ID and the time when it transmits the Transpond signal.

If the Dropout Delay Time is shorter than the Transpond Delay Time, the transceiver performs the Transpond function after the Dropout Delay Timer expires. ([Refer to 23.7.7 Dropout Delay Time.](#))

You can configure the Transpond Delay Time using KPG-89D.

■ Configuration using KPG-89D

- Configuring the Transpond Delay Time (Refer to FPRG 6.7.5 Trunking tab - Transpond Delay Time.)

16 CONVENTIONAL GROUP

The Conventional Groups are groups of Simplex and Semi-duplex Conventional Channels.

You can configure the Zone to the Conventional Group using KPG-89D.

16.1 Zone

You can configure the following functions to the Zone using KPG-91D.

- Zone Name
- Data Zone-CH/GID
- Home Channel
- Home Channel Operator Selectable
- Optional Signaling Decode Condition
- Audio Control
- Time-out Timer (TOT)
- TOT Pre-alert
- TOT Rekey Time
- TOT Reset Time
- BCL Override
- Zone Add
- Scan List

16.1.1 Zone Name

The Zone Name function allows you to assign a name to a Zone. (Refer to 3.6.1 Zone Name.)

You can configure the Zone Name using KPG-89D.

■ Configuration using KPG-89D

- Configuring the Zone Name (Refer to FPRG 6.2.1 Zone Name.)

16.1.2 Data Zone-CH/GID

This function is used to separate the CH/GID for Data communications from the CH/GID for Voice communications. (Refer to 25.1.2 Data Zone-CH/GID.)

You can configure the Data Zone-CH/GID using KPG-89D.

■ Configuration using KPG-89D

- Configuring the Data Zone-CH/GID (Refer to FPRG 6.2.2 Data Zone-CH/GID.)

16.1.3 Home Channel

This function allows you to jump to the frequently used Channel with a press of the key. (Refer to 2.7 Home CH/GID.)

You can configure the Home Channel using KPG-89D.

Note: You can only jump to the Channel in the same Zone.

■ Configuration using KPG-89D

- Configuring the Home Channel (Refer to FPRG 6.2.3 Home Channel.)
- Assigning functions to the **PF** keys (Refer to FPRG 6.8 Key Assignment.)

16.1.4 Home Channel Operator Selectable

This function allows the user to configure the Home Channel. When this function is enabled, you can change the Home Channel by selecting the channel to be configured as the Home Channel and pressing and holding the **PF Home CH/GID** key for more than 3 seconds.

You can enable/disable this function using KPG-89D.

■ Configuration using KPG-89D

- Configuring the Home CH Operator Selectable function (Refer to FPRG 6.2.4 Home Channel Operator Selectable.)

16.1.5 Optional Signaling Decode Condition

You can select Carrier Decode or QT/DQT Decode as the Decode condition.

You can configure the Optional Signaling Decode Condition using KPG-89D.

■ Configuration using KPG-89D

- Configuring the Optional Signaling Decode condition (Refer to FPRG 6.2.5 Optional Signaling Decode condition.)

16.1.6 Audio Control

This function allows you to configure the conditions to disable the Mute function using the QT/DQT and Option Signaling. (Refer to [18.3 Signaling \(Audio Control\)](#).)

You can configure the Audio Control function using KPG-89D. You can configure the function to each Zone.

■ Configuration using KPG-89D

- Configuring the Audio Control (Refer to FPRG 6.2.6 Audio Control.)

16.1.7 Time-out Timer (TOT)

This function limits the continuous transmission time (TOT). (Refer to [11 Time-out Timer](#).)

You can configure this period using KPG-89D.

■ Configuration using KPG-89D

- Configuring the Time-out Timer (TOT) (Refer to FPRG 6.2.7 Time-out Timer (TOT).)

16.1.8 TOT Pre-alert

This function allows you to notify a user that the Time-out timer is about to expire. (Refer to [11.1.2 TOT Pre-alert](#).)

You can configure the timing to emit the TOT Pre-alert tone using KPG-89D.

■ Configuration using KPG-89D

- Configuring the TOT Pre-alert (Refer to FPRG 6.2.8 TOT Pre-alert.)

16.1.9 TOT Rekey Time

The function is used to configure the duration of the time from the time when the Time-out Timer starts operating to the time when the transceiver starts transmitting again. (Refer to [11.1.3 TOT Rekey Time](#).)

(Refer to [11.1.3 TOT Rekey Time](#).)

You can configure the TOT Rekey Time using KPG-89D.

■ Configuration using KPG-89D

- Configuring the TOT Rekey Time (Refer to FPRG 6.2.9 TOT Rekey Time.)

16.1.10 TOT Reset Time

The TOT Reset Time is the function to reset the Time-out Timer. (Refer to [11.1.4 TOT Reset Time](#).)

You can configure the TOT Reset Time using KPG-89D.

■ Configuration using KPG-89D

- Configuring the TOT Reset Time (Refer to FPRG 6.2.10 TOT Reset Time.)

16.1.11 BCL Override

This function allows the transceiver to transmit data while the transceiver channel is busy, even if the transceiver do not normally transmit on a busy channel. (Refer to [12.2 BCL Override](#).)

You can enable/disable this function using KPG-89D.

■ Configuration using KPG-89D

- Configuring the BCL Override function (Refer to FPRG 6.2.11 BCL Override.)

16.1.12 Zone Add

You can configure the Zone to be added to the Scan List using KPG-89D.

■ Configuration using KPG-89D

- Configuring the Zone Add function (Refer to FPRG 6.2.12 Zone Add.)

16.1.13 Scan List

You can configure the Scan List according to the configuration of the Scan List Table using KPG-89D.

■ Configuration using KPG-89D

- Configuring the Scan List (Refer to FPRG 6.2.13 Scan List and FPRG 6.2.15 Scan List Table window.)

16.2 Channel

You can configure the following functions relating to the Conventional Group Channel using KPG-89D.

- Receive Frequency
- Transmit Frequency
- QT/DQT Decode
- QT/DQT Encode
- Channel Name
- Transmit Power
- Wide/Narrow
- Optional Signaling
- Busy Channel Lockout
- PTT ID
- Beat Shift
- Scan Add
- Compander
- Data
- Voice Scrambler
- Scrambler Code

16.2.1 Receive Frequency

You can configure the receive frequency using KPG-89D.

■ Configuration using KPG-89D

- Configuring the Receive Frequency (Refer to FPRG 6.3.3 Receive Frequency.)

16.2.2 Transmit Frequency

You can configure the transmit frequency using KPG-89D.

■ Configuration using KPG-89D

- Configuring the Transmit Frequency (Refer to FPRG 6.3.4 Transmit Frequency.)

16.2.3 QT/DQT Decode

This function allows you to configure the QT/DQT decode code. QT/DQT is the Signaling for facilitating communication within a Group when sharing the same channel with several groups (Talk Group). ([Refer to 18.1 QT/DQT Decode/Encode.](#))

You can configure the QT/DQT Decode code to each channel using KPG-89D.

■ Configuration using KPG-89D

- Configuring the QT/DQT Decode (Refer to FPRG 6.3.5 QT/DQT Decode.)

16.2.4 QT/DQT Encode

This function allows you to configure the QT/DQT Encode code. QT/DQT is the Signaling for facilitating communication within a Group when sharing the same channel with several groups (Talk Group). ([Refer to 18.1 QT/DQT Decode/Encode.](#))

You can configure the QT/DQT Encode code to each channel using KPG-89D.

■ Configuration using KPG-89D

- Configuring the QT/DQT Encode (Refer to FPRG 6.3.6 QT/DQT Encode.)

16.2.5 Channel Name

This function allows you to assign a name to a Channel. ([Refer to 3.6.3 Channel Name.](#))

You can configure the Channel Name using KPG-89D.

■ Configuration using KPG-89D

- Configuring a Channel Name (Refer to FPRG 6.3.7 Channel Name.)

16.2.6 Transmit Power

Transmit Power is the transmission power of the transceiver. You can select Low when a repeater or the receiving party is nearby.

This will extend the operating time of TK-2180/ 3180 becomes longer.

Press the **PF Low Transmit Power** key to switch the transmit power (High/Low) of the transceiver.

You can configure the Transmit Power using KPG-89D.

Note: You can configure the **PF Low Transmit Power** key only in TK-2180/ 3180.

■ Configuration using KPG-89D

- Configuring the Transmit Power (Refer to FPRG 6.3.8 Transmit Power.)
- Assigning functions to the **PF** keys (Refer to FPRG 6.8 Key Assignment.)

16.2.7 Wide/Narrow

This function allows you to select the operational bandwidth for the channel.

You can select Wide or Narrow using KPG-89D.

■ Configuration using KPG-89D

- Configuring the Wide/Narrow (Refer to FPRG 6.3.9 Wide/Narrow.)

16.2.8 Optional Signaling

You can use the Option Signaling to make an individual call. (Refer to 18.2 Optional Signaling.)

You can configure the Optional Signaling for each channel using KPG-89D.

■ Configuration using KPG-89D

- Configuring the Optional Signaling (Conventional Group) (Refer to FPRG 6.3.10 Optional Signaling.)

16.2.9 Busy Channel Lockout

This function automatically prevents the transmission so as not to interfere other communications. (Refer to 12 Busy Channel Lockout.)

You can configure the Busy Channel Lockout function for each channel using KPG-89D.

■ Configuration using KPG-89D

- Configuring the Busy Channel Lockout function (Refer to FPRG 6.3.11 Busy Channel Lockout.)

16.2.10 PTT ID

This is the identification code transmitted when the **PTT** switch is pressed and/or released. (Refer to 14 PTT ID.)

You can configure the transmit timing of the PTT ID using KPG-89D.

■ Configuration using KPG-89D

- Configuring the PTT ID (Refer to FPRG 6.3.12 PTT ID.)

16.2.11 Beat Shift

This function eliminates the problems of the transceiver's internal beat caused by internal oscillators. You can enable/disable this function when the VGS-1 is installed in the transceiver. (Refer to 1.8 Beat Shift.)

You can enable/disable the Beat Shift function using KPG-89D.

■ Configuration using KPG-89D

- Enabling/disabling the Beat Shift function for each channel (Refer to FPRG 6.3.13 Beat Shift.)

16.2.12 Scan Add

You can select the channel to be added to the Scan List. You can configure the Scan Add function using KPG-89D.

■ Configuration using KPG-89D

- Configuring the Scan Add function (Refer to FPRG 6.3.14 Scan Add.)

16.2.13 Compander

This function allows you to improve the transceiver sound quality. (Refer to 1.7 Compander.)

You can enable/disable the Compander function using KPG-89D.

■ Configuration using KPG-89D

- Configuring the Compander function to each channel (Refer to FPRG 6.3.15 Compander.)

16.2.14 Data

You can select the Channel to be used for Data communications or Voice communications. Check the **Data** checkbox to use the channel for data communications.

You can configure the Data function using KPG-89D.

■ Configuration using KPG-89D

- Configuring the Data function (Refer to FPRG 6.3.16 Data)

16.2.15 Voice Scrambler

This function allows you to scramble the voice transmission for private communications. ([Refer to 29 Voice Scrambler.](#))

You can enable/disable the Voice Scrambler function using KPG-89D.

■ Configuration using KPG-89D

- Configuring the Voice Scrambler function (Refer to FPRG 6.3.17 Voice Scrambler.)

16.2.16 Scrambler Code

You can configure the Scrambler Code. ([Refer to 29 Voice Scrambler.](#))

There are two types of Scrambler function: Built-in and optional Voice Scrambler board. You can configure the Scrambler Code for the optional Voice Scrambler board.

You can configure the Scrambler Code using KPG-89D.

■ Configuration using KPG-89D

- Configuring the Scrambler Code (Refer to FPRG 6.3.18 Scrambler Code.)

17 LTR TRUNKING

LTR Trunking Systems are multiple repeater systems that utilize the LTR Trunking protocol. Each transceiver has its own Group ID so that various calls can be processed easily.

In LTR Trunking systems, the transceiver communicates via the repeater and repeater controller. In the system, you can communicate with other parties using an available repeater channel automatically.

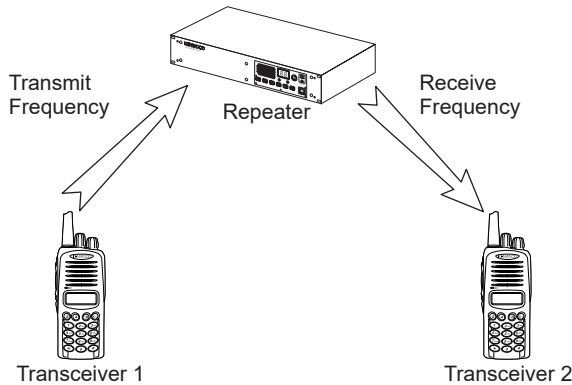

Figure 17-1 LTR Trunking System

The following data format is used to transmit/receive LTR system information between the repeater and the transceiver.

Sync	Area	Go to Channel	Home Channel	ID	Free Channel	CRC
9	1	5	5	8	5	7
(40 bit @ 3.36 ms for 134.4 ms frame)						

Figure 17-2 LTR Data Format

The transceiver uses the LTR ID (Group ID) to make a call to the receiving party. You can communicate when the transmitting party's Encode ID matches the receiving party's Decode ID.

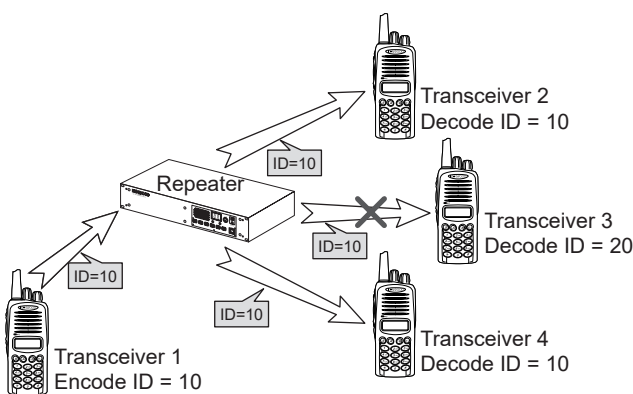

Figure 17-3 Communication in LTR Trunking System

Note: LTR stands for the Logic Trunked Radio and it is a registered trademark of E. F. Johnson company.

17.1 Zone

You can configure the following functions to the LTR Trunking System Zone using KPG-89D.

- Zone Name
- Scan Weight
- Wide/Narrow
- Data Zone-CH/GID
- Data Delay Time
- Home GID
- Home GID Operator Selectable
- Time-out Timer (Dispatch)
- Time-out Timer (Telephone)
- Audio Control
- Encode Data Type
- Zone Add
- Scan List
- Auto Telephone Search
- TA Busy Channel Lockout
- TA Key
- Fix ID
- Telephone (Block IDs)
- TX Inhibit (Block IDs)
- Decode ID (Block IDs)

17.1.1 Zone Name

The Zone Name function allows you to assign a name to a Zone. (Refer to 3.6.1 Zone Name.)

You can configure the Zone Name using KPG-89D.

■ Configuration using KPG-89D

- Configuring the Zone Name (Refer to FPRG 6.5.1 Zone Name.)

17.1.2 Scan Weight

This function allows you to configure the decode period of the LTR ID transmitted from the Repeater during scan.

The transceiver uses the LTR ID provided by the repeater and performs Trunkout operation. If there are several Group IDs having the same Home number in the LTR System, other users having the same Home number must Trunkout. Therefore, it will take long time to receive its own LTR ID. In this case, you can configure the Scan Weight longer so as not to miss the LTR Data during scan.

1 weight is approximately 500 ms.

You can configure the Scan Weight using KPG-89D.

■ Configuration using KPG-89D

- Configuring the Scan Weight (Refer to FPRG 6.5.2 Scan Weight.)

17.1.3 Wide/Narrow

This function allows you to select the channel's operational bandwidth.

You can select Wide or Narrow using KPG-89D.

■ Configuration using KPG-89D

- Configuring the Wide/Narrow (Refer to FPRG 6.5.3 Wide/Narrow.)

17.1.4 Data Zone-CH/GID

This function is used to separate the CH/GID for Data communications from the CH/GID for Voice communications. ([Refer to 25.1.2 Data Zone-CH/GID.](#))

You can configure the Data Zone-CH/GID using KPG-89D.

■ Configuration using KPG-89D

- Configuring the Data Zone-CH/GID (Refer to FPRG 6.5.4 Data Zone-CH/GID.)

17.1.5 Data Delay Time

This function allows you to configure the duration from the time the transceiver starts transmitting to the time when it starts transmitting LTR Data. You can use this function when it is difficult for the transceiver to link to the repeater.

You can configure the Data Delay Time using KPG-89D.

■ Configuration using KPG-89D

- Configuring the Data Delay Time (Refer to FPRG 6.5.5 Data Delay Time)

17.1.6 Home GID

This function allows the transceiver to jump to the frequently used GID with a press of the key. ([Refer to 2.7 Home CH/GID.](#))

You can configure the Home GID using KPG-89D.

■ Configuration using KPG-89D

- Configuring the Home GID (Refer to FPRG 6.5.6 Home GID.)
- Assigning functions to the **PF** keys (Refer to FPRG 6.8 Key Assignment.)

17.1.7 Home GID Operator Selectable

This function allows a user to configure the Home GID. When this function is enabled, the user can change the Home GID by selecting the channel to be configured as the Home GID and pressing and holding the **PF Home CH/GID** key for more than 3 seconds.

You can enable/disable the Home GID Operator Selectable function using KPG-89D.

■ Configuration using KPG-89D

- Configuring the Home GID Operator Selectable function (Refer to FPRG 6.5.7 Home GID Operator Selectable.)

17.1.8 Time-out Timer (Dispatch)

The Time-out Timer (Dispatch) is the maximum continuous transmission time to communicate using the Dispatch ID. ([Refer to 11.2.1 Time-out Timer \(Dispatch\).](#))

You can configure the Time-out Timer (Dispatch ID) using KPG-89D.

■ Configuration using KPG-89D

- Configuring the TOT (Dispatch) (Refer to FPRG 6.5.8 Time-out Timer (Dispatch).)

17.1.9 Time-out Timer (Telephone)

The Time-out Timer (TEL) is the maximum continuous transmission time to communicate using the Telephone ID. ([Refer to 11.2.2 Time-out Timer \(Telephone\).](#))

You can configure the Time-out Timer (Telephone) using the KPG-89D.

■ Configuration using KPG-89D

- Configuring the TOT (Telephone) (Refer to FPRG 6.5.9 Time-out Timer (Telephone).)

17.1.10 Audio Control

This function allows you to configure the conditions to disable the Mute function using the QT/DQT and Optional Signaling. (Refer to [18.3 Signaling \(Audio Control\)](#).)

You can configure the Audio Control function to each Zone using KPG-89D.

■ Configuration using KPG-89D

- Configuring the Audio Control (Refer to FPRG 6.5.10 Audio Control.)

17.1.11 Encode Data Type

This function allows you to reverse the logic of the LTR Message to be sent.

You can configure the Encode Data Type using KPG-89D.

■ Configuration using KPG-89D

- Configuring the Encode Data Type (Refer to FPRG 6.5.11 Encode Data Type.)

17.1.12 Zone Add

You can configure the Zone to be added to the Scan List using KPG-89D.

■ Configuration using KPG-89D

- Configuring the Zone Add function (Refer to FPRG 6.5.12 Zone Add.)

17.1.13 Scan List

You can configure the Scan List according to the configuration of the Scan List Table using KPG-89D.

■ Configuration using KPG-89D

- Configuring the Scan List (Refer to FPRG 6.5.13 Scan List and FPRG 6.5.25 Scan List Table window.)

17.1.14 Auto Telephone Search

This function allows the transceiver to search for an available repeater and automatically link to the repeater.

The System that meets the following conditions is targeted for the search. When no System matches these conditions, the Deny Tone sounds and the Auto Telephone Search function does not operate.

- The System in which Auto TEL Search is set to “Yes” in the **Zone Edit** window > **Auto Telephone Search**.
- The System with at least one repeater in which Telephone Repeater is configured to “Yes” in the **Repeater Information** window > **Telephone Repeater**.
- The System in which Telephone ID (Block Telephone IDs) is configured in the **Zone Edit** window > **Telephone (Block IDs)** and there is at least 1 group in the configured range.

You can configure the Zone to be added to the Auto Telephone Search List using KPG-89D.

Note: The Zone, from which Auto Telephone Search starts, is always searched, even when the Auto Telephone Search is disabled.

■ Configuration using KPG-89D

- Configuring the Auto Telephone Search function (Refer to FPRG 6.5.15 Auto Telephone Search.)
- Assigning functions to the **PF** keys (Refer to FPRG 6.8 Key Assignment.)

17.1.15 TA Busy Channel Lockout

If a user transmits on a channel while other groups are using that channel, the user may interfere with the communications. This function prevents such interference. (Refer to [13.2.1 TA Busy Channel Lockout](#).)

You can enable/disable the TA Busy Channel Lockout function using KPG-89D.

■ Configuration using KPG-89D

- Configuring the TA Busy Channel Lockout function (Refer to FPRG 6.5.16 TA Busy Channel Lockout.)

17.1.16 TA Key

This function allows you to enable/disable the **PF Talk Around** key operation. (Refer to [13.2.2 TA Key](#).)

You can enable/disable the TA Key operation using KPG-89D.

■ Configuration using KPG-89D

- Configuring the TA Key (Refer to FPRG 6.5.17 TA Key.)

17.1.17 Fix ID

The Fix ID is the LTR ID having higher priority than the Group ID. The transceiver automatically switches to the Fix ID. A user can use this ID when the user wants to receive a call while receiving a call with other IDs.

The following is the priority to move to the Fix ID.

1st Fix ID > 2nd Fix ID > Displayed Group ID (Revert ID) > Selectable ID (Scan Add = Yes) > Decode ID

When receiving a Fix ID, Call Indicator and Option Signaling activate.

The transceiver does not receive the Fix ID in the following conditions.

- Receiving a Fix ID call while communicating with a telephone repeater.
- Receiving a call in Trunkout Mode using a repeater other than the Home Repeater
- Receiving a Fix ID call in the Data Group

You can configure the Fix ID using KPG-89D.

■ Configuration using KPG-89D

- Configuring the Fix ID (Refer to FPRG 6.5.18 ID (Fix ID).)

17.1.18 Telephone (Block IDs)

This function allows you to configure a unique ID to communicate with a telephone repeater. A user can make and receive telephone calls from the transceiver.

You can configure the Telephone (Block IDs) using KPG-89D.

■ Configuration using KPG-89D

- Configuring the Telephone (Block IDs) (Refer to FPRG 6.5.22 Decode.)

17.1.19 TX Inhibit (Block IDs)

This function restricts the transmission ID immediately after receiving the specified ID.

A user can use this function when the user does not want to transmit immediately after receiving the ID while sharing Group ID with other parties.

The user cannot transmit until the TX Inhibit Time expires after receiving the TX Inhibit ID when this function is enabled.

You can configure the TX Inhibit (Block IDs) and the TX Inhibit Time using KPG-89D. You can configure this function to each transceiver.

Note:

- ◆ The TX Inhibit (Block IDs) function is disabled when the Zone/ Group ID is changed.
- ◆ When the transceiver receives the TX Inhibit (Block IDs) during scan, the transmission remains inhibited for the TX Inhibit Time. It resets the TX Inhibit Time when scan resumes, allowing the transceiver to transmit again.
- ◆ When the transceiver receives the TX Inhibit (Block IDs) while communicating with the repeater, the transmission remains inhibited for the TX Inhibit Time.

■ Configuration using KPG-89D

- Configuring the Transmit Inhibit (Block IDs) (Refer to FPRG 6.5.23 Transmit Inhibit (Block IDs).)
- Configuring the TX Inhibit Time (Refer to FPRG 6.7.5 Trunking tab - TX Inhibit Time.)

17.1.20 Decode ID (Block IDs)

This function allows you to configure the receive only ID. The transceiver squelch opens when receiving a call with the Decode ID.

You can configure the Decode ID (Block IDs) using KPG-89D.

■ Configuration using KPG-89D

- Configuring the Decode ID (Block IDs) (Refer to FPRG 6.5.24 Decode (Block IDs).)

17.2 Group ID

You can configure the following functions to the LTR Trunking System Group ID using KPG-89D.

- Encode/Decode ID
- GID Name
- Transmit Power
- Optional Signaling
- PTT ID
- Call Indicator
- Horn Alert (TK-7180/ 8180 only)
- Scan Add
- Transpond
- Talk Around
- Compander
- Data
- Scrambler
- Scrambler Code

17.2.1 Encode/ Decode ID

The Encode ID is the LTR ID used to transmit.

The Decode ID is the LTR ID used to open the squelch and then allows a user to communicate.

The transceiver communicates within a Group using the same LTR ID.

You can configure the Encode/ Decode ID using KPG-89D.

■ Configuration using KPG-89D

- Configuring the Encode ID (Refer to FPRG 6.6.3 Encode ID.)
- Configuring the Decode ID (Refer to FPRG 6.6.4 Decode ID.)

17.2.2 GID Name

This function allows you to assign a name to a Group ID. (Refer to 3.6.4 GID Name.)

You can configure the GID Name using KPG-89D.

■ Configuration using KPG-89D

- Configuring a GID Name (Refer to FPRG 6.6.5 GID Name)

17.2.3 Transmit Power

Transmit Power is the transmission power of the transceiver. (Refer to 1.4 Transmit Output Power.)

Press the **PF Low Transmission** Power key to alternate the output (High/Low) of the transceiver when using the TK-2180/ 3180.

A user cannot change the transmission power manually for the TK-7180/ 8180.

You can configure the Transmit Power using KPG-89D.

■ Configuration using KPG-89D

- Configuring the Transmit Power (Refer to FPRG 6.6.6 Transmit Power.)
- Assigning functions to the **PF** keys (Refer to FPRG 6.8 Key Assignment.)

17.2.4 Optional Signaling

You can install the option signaling board to make an individual call. (Refer to 18.2 Optional Signaling.)

You can configure the optional signaling parameters to each channel using KPG-89D.

■ Configuration using KPG-89D

- Configuring Optional Signaling (Trunking System) (Refer to FPRG 6.6.7 Optional Signaling.)

17.2.5 PTT ID

This is the identification code transmitted when the **PTT** switch is pressed and/or released. (Refer to 14 PTT ID.)

You can configure the timing to transmit the PTT ID using KPG-89D.

■ Configuration using KPG-89D

- Configuring the PTT ID (Refer to FPRG 6.6.8 PTT ID.)

17.2.6 Call Indicator

The call indicator notifies a user that the transceiver has received calls.

The user can use this function in noisy environments or when he/she is away from the transceiver. The operation of this function varies between the time when receiving the Group ID and the time when receiving the Fix ID.

You can configure the Call Indicator using KPG-89D.

Table 17-1 Call Indicator Operation

Received ID	Operation
Group ID	The "CAL" icon appears on the sub display to notify the user that the transceiver received a call. The "CAL" icon continues to blink after the conversation has finished. The "CAL" icon alternates to be lit from blinking when receiving a call from a high priority Fix ID. Press any key to stop the blinking "CAL" icon.
Fix ID	The "CAL" icon blinks on the sub display to notify the user that the transceiver received a call. The "CAL" icon continues to light after the conversation has finished. The "CAL" icon continues to light after the call from the Group ID has finished. Press any key to stop the blinking "CAL" icon. However, the following keys cannot be used. PF Lamp key PF LCD Brightness key

Note: The "CAL" icon remains lit even if the transceiver receives another Group ID or the Group ID.

■ Configuration using KPG-89D

- Configuring the Call Indicator (Refer to FPRG 6.6.9 Call Indicator.)

17.2.7 Horn Alert

(TK-7180/ 8180 only)

You can enable/disable the Horn Alert function using KPG-89D. (Refer to 9 Horn Alert.)

■ Configuration using KPG-89D

- Configuring the Horn Alert (Refer to FPRG 6.6.10 Horn Alert.)

17.2.8 Scan Add

You can configure the Group ID to be added to the Scan List using KPG-89D.

■ Configuration using KPG-89D

- Configuring the Scan Add function (Refer to FPRG 6.6.11 Scan Add.)

17.2.9 Transpond

You can enable/disable the Transpond function using KPG-89D. (Refer to 15 Transpond.)

■ Configuration using KPG-89D

- Configuring the Transpond function (Refer to FPRG 6.6.12 Transpond.)

17.2.10 Talk Around

You can enable/disable the Talk Around function using KPG-89D. (Refer to 13 Talk Around.)

■ Configuration using KPG-89D

- Configuring the Talk Around function (Refer to FPRG 6.6.13 Talk Around.)

17.2.11 Compander

The "Compander" stands for "COMpressor" and "exPANDER". This function allows the transceiver to improve the sound quality.

You can enable/disable the Compander function using KPG-89D. (Refer to 1.7 Compander.)

■ Configuration using KPG-89D

- Configuring the Compander function to each Group ID (Refer to FPRG 6.6.14 Compander.)

17.2.12 Data

You can configure the Group ID to be used for Data communications or Voice communications using KPG-89D.

■ Configuration using KPG-89D

- Configuring the Data function (Refer to FPRG 6.6.15 Data.)

17.2.13 Scrambler

This function allows the transceiver to scramble the voice in special format to keep the conversation private. (Refer to 29 Voice Scrambler.)

You can enable/disable the Voice Scrambler function using KPG-89D.

■ Configuration using KPG-89D

- Configuring the Voice Scrambler function (Refer to FPRG 6.6.16 Scrambler.)

17.2.14 Scrambler Code

Configuring the Scrambler Code.

You can configure the Scrambler Code using KPG-89D. ([Refer to 29 Voice Scrambler.](#))

There are 2 types of Scrambler function: uilt-in and optional Voice Scrambler Board . You can configure the Scrambler code for the Scrambler function using the optional Voice Scrambler board.

■ Configuration using KPG-89D

- Configuring the Scrambler Code (Refer to FPRG 6.6.17 Scrambler Code.)

17.3 Home Repeater

You can configure the following functions to the LTR Trunking System using KPG-89D.

- Area Code
- Home Repeater
- Repeater Information Table

17.3.1 Area Code

This function prevents interference from adjacent systems. The Area Code is normally configured to "0". When the transceiver suffers from interference, configure the Area Code of one system to 0 and the adjacent system to 1.

You can configure the Area Code using KPG-89D.

■ Configuration using KPG-89D

- Configuring the Area Code (Refer to FPRG 6.4.1 Area Code.)

17.3.2 Home Repeater

The Home Repeater is used to receive various information from the LTR Trunking system. The transceiver automatically responds to the repeater such as transmitting/receiving data, and Trunkout via this repeater.

You can also transmit/receive using the Home Repeater when the Home Repeater is available.

The Home Repeater provides the Repeater Number to the user while other parties use the Home Repeater. The receiving party's transceiver moves to the Trunkout Repeater to receive.

You can configure the Home Repeater using KPG-89D.

■ Configuration using KPG-89D

- Configuring the Home Repeater (Refer to FPRG 6.4.2 Home Repeater.)

17.3.3 Repeater Information Table

In LTR Trunking system, the transceiver communicates via a repeater.

You can configure a maximum of 20 Repeaters' information to the Repeater Information Table for each Zone.

You can configure the following functions for the Repeater Table Information using KPG-89D.

Table 17-2 Repeater Information Table Configuration

	Operation
Receive Frequency	Configure the receive frequency.
Transmit Frequency	Configure the transmit frequency.
Beat Shift	Configure the Beat Shift function. (Refer to 1.8 Beat Shift.)
Telephone	Configure the repeater to be used as the RIC (Repeater Inter Connect).

■ Configuration using KPG-89D

- Configuring the Receive Frequency (Refer to FPRG 6.4.3 Receive Frequency.)
- Configuring the Transmit Frequency (Refer to FPRG 6.4.4 Transmit Frequency.)
- Configuring the Beat Shift function (Refer to FPRG 6.4.5 Beat Shift.)
- Configuring the Telephone function (Refer to FPRG 6.4.6 Telephone.)

17.4 Telephone Interconnect

In LTR Trunking Systems, you can connect to the PSTN (Public Switched Telephone Network) via the RIC (Repeater Inter Connect).

17.4.1 Connecting to the Phone Line

To make a phone call using the transceiver, you must use a microphone with a keypad. However, the microphone with a keypad is not required to make a phone call when using the Autodial function.

■ Transceiver Operation

● Connecting to the Phone Line Using the Auto Telephone Function

1. Select the phone number you want to call using the Autodial function.
(Refer to 20 DTMF.)

2. Press **[S2]**.

The transceiver is automatically connected to the phone line.

A user cannot dial the phone number by pressing the **PF Auto Telephone** key if no number is configured, even though the transceiver enters the Off-hook status (dial tone standby). While the transceiver receives the dial tone, you can transmit the phone number using the Manual Dialing function or the Keypad Auto PTT function.

● Connecting to the Phone Line using the PTT Switch

1. Select the GID that the Telephone ID is configured.

The “” icon appears.

2. Select the phone number to call using the Autodial function.
(Refer to 20 DTMF.)

3. Press the **PTT** switch.

The transceiver is connected to the phone line.

The transceiver is connected to the phone line when the **PTT** switch is pressed while the GID that the Telephone ID is configured. In this case, the transceiver enters Off-hook status (dial tone standby). While the transceiver receives the receiving tone, the user can transmit the phone number using the Manual Dialing function or the Keypad Auto PTT function.

● Disconnecting the Phone Line

1. Press **[#]** or the **PF Disconnect** key during communication.

The transceiver is disconnected from the phone line.

■ Configuration using KPG-89D

- Assigning functions to the **PF** keys (Refer to FPRG 6.8 Key Assignment.)

17.4.2 Auto Telephone Search

This function allows the transceiver to search for an available RIC repeater and automatically connects the transceiver to the repeater.

The transceiver automatically searches for an available telephone interconnect line to make a call. This function is similar to the memory dial function of a mobile phone, allowing the user to easily make a call.

Zones satisfying the following conditions are targeted for the search. When no Zone matches these conditions, the Deny Tone sounds and the Auto Telephone Search function does not operate.

- At least, 1 Zone is in the Auto Telephone Search list.
- There is a RIC repeater in the above Zone.
- There is a Group ID having the LTR ID configured as the Encode ID used to connect to a phone line in the above Zone.

■ Transceiver Operation

1. Press the **PF Auto Telephone** key.

The “AUTO TEL” appears on the Main Display and the “” icon blinks.

The transceiver starts the Auto Telephone Search.

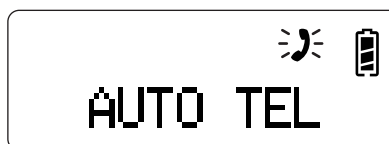

TK-2180/ 3180

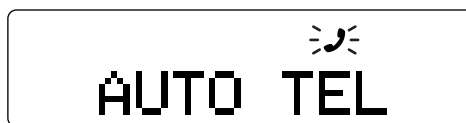

TK-7180/ 8180

The “” icon appears when the transceiver is connected to the phone line.



TK-2180/ 3180

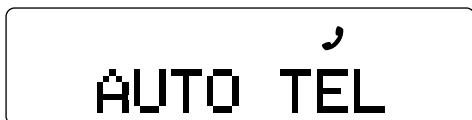

TK-7180/ 8180



TK-2180/ 3180



TK-7180/ 8180

The transceiver emits the Ringer Tone when the Repeater becomes available.

If no repeaters are available for 60 seconds, the Deny Tone sounds and the Auto Telephone Search ends.

2. Select the phone number to call using the Autodial function. (Refer to 20 DTMF.)

The transceiver dials the phone number.

■ Configuration using KPG-89D

- Assigning functions to the PF keys (Refer to FPRG 6.8 Key Assignment.)
- Configuring the Auto Telephone Search function (Refer to FPRG 6.5.15 Auto Telephone Search.)

Note:

- ◆ This function operates when making a phone call. It does not work for dispatch purposes.
- ◆ The transceiver pauses the Free System Ringback operation when changing the Zone/Group ID or while receiving a call.
- ◆ The transceiver pauses scanning when it enters Free System Ringback Mode during scan. The transceiver resumes scan after exiting from Free System Ringback Mode.

■ Configuration using KPG-89D

- Configuring the Free System Ringback (Refer to FPRG 6.7.5 Trunking tab - Free System Ringback.)

17.4.3 Free System Ringback

This function configures the transceiver to emit the tone when the repeater becomes available.

A user can use this function if the user wants to be notified that a repeater becomes available when all repeaters are busy.

You can enable/disable this function using KPG-89D.

■ Transceiver Operation

1. Press the PTT switch or activate the PF Ext. PTT (Voice) port while the transceiver is emitting the Busy Tone.

The transceiver emits the Free System Ringback Mode Tone and it enters in Free System Ringback Mode.

17.5 System Search

This function enables the transceiver to automatically search for an available system. The transceiver may be outside of the repeater service area when pressing the PTT switch. In this case, you can use this function to search for an available system.

The transceiver performs the System Search even if it cannot establish a link using a data channel. In this case, you must configure the transceiver to receive data from the base station to perform the scan.

■ Configuration using KPG-89D

- Configuring the System Search function (Refer to FPRG 6.7.5 Trunking tab - System Search.)

17.5.1 System Search for Voice Channels

Two types of System Search is available: Manual and Auto.

■ Transceiver Operation

● Manual

1. Press **[S]** while the Intercept Tone sounds.
The System Search Mode Tone sounds after the Intercept Tone stops.
2. Release the **PTT** switch or the PF Ext. PTT (Voice) port.
System Search starts from the next available system from where the connection failed.
The transceiver stop searching when it finds an available system.
If no system is available, the Search ends and the Search End Tone sounds.
3. Press the **PTT** switch or activate the PF Ext. PTT (Voice) port.

● Auto

1. Release the **PTT** switch or activate the PF Ext. PTT (Voice) port while the Intercept Tone sounds.
The System Search Mode Tone sounds after the Intercept Tone stops sounding.
The transceiver starts the System Search.
The transceiver stops searching when it finds an available System.
If no system is available, the Search ends and the Search End Tone sounds.
2. Press the **PTT** switch or activate the PF Ext. PTT (Voice) port.

Note:

- ◆ The Voice Channel System Search starts from the next System from where the transceiver failed to connect.
- ◆ During System Search, the System Search Tone is transmitted when performing the System Up.
- ◆ The PF Ext. PTT port does not operate during System Search.

17.5.2 System Search for Data Channels

You can select "Auto" from the System Search pulldown menu. The System Search does not work when "Manual" or "Disable" is selected.

Follow the procedures below to activate the System Search.

1. The transceiver starts System Search when it fails connecting to the repeater.
The transceiver starts System Search when the PF Ext. PTT (Data) port and the PF DTC port are disabled while using the PF Ext. PTT (Data) port and the PF DTC port connected to an external device.
The transceiver starts System Search when the PF Data PTT port is disabled while using the PF Data PTT only.
2. System Search starts from the next Zone from where the transceiver failed to connect. The transceiver stops searching when it finds an available System. If no system is available in all Zones configured using KPG-89D, the Search ends.
3. The external device enables PF Ext. PTT (Data) port + PF DTC port, and the PF Data PTT port. The transceiver moves to the data channel to transmit.

Note:

- ◆ The System Search for data channels is disabled for the Data CH/GID Dwell Time.
- ◆ The System Search operates even if "GTC" is configured for FleetSync data communication.

17.6 Clear to Talk

This function emits the Delay Tone when accessing the repeater more than 3 times after pressing the **PTT** switch.

The Delay Tone sounds when the "Clear to Talk" checkbox is not checked. A user recognizes that it is difficult to access the repeater since the Delay Tone sounds.

Note: The TK-280/ 780 emits the PTT Proceed Tone when the Clear to Talk function is enabled. You can configure the PTT Proceed Tone separately in the TK-2180/ 7180.

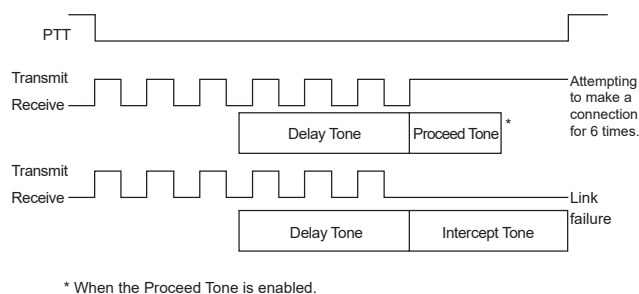

Figure 17-4 Clear to Talk

You can enable/disable the Clear to Talk function using KPG-89D.

■ Configuration using KPG-89D

- Configuring the Clear to Talk (Refer to FPRG 6.7.5 Trunking tab - Clear to Talk.)

17.7 ARQ Mode

This function allows a user to finish data communications in a Trunking System with a single link operation.

When performing data transmission in a LTR Trunking System, the transceiver is normally required to link to a repeater prior to each data transmission. The data transmission may fail when the system is busy and there is no available repeater channel. To solve this problem, ARQ Mode allows a user to finish the data communication operation in the Trunking system with a single link.

You can use the ARQ function with external Modem and FleetSync.

You can enable/disable ARQ Mode using KPG-89D

Note:

- ◆ The transceiver does not transmit when no repeater is available as the PF Ext. PTT (Voice) port, the PF Ext. PTT (Data) port, or the PF Data PTT is pressed. When no repeater is available, the System Busy terminal becomes active.
- ◆ The System Busy terminal becomes active when no repeater is available while the transceiver is in receiving mode, even if the PF Ext. PTT (Voice) port, the PF Ext. PTT (Data) port, or the **PF Data PTT** key is not pressed.

■ Configuration using KPG-89D

- Configuring ARQ Mode (Refer to FPRG 6.7.5 Trunking tab - ARQ Mode.)

17.7.1 Transceiver Operation When Using the ARQ Function in the External Modem

When the DTC terminal of the external modem is low, the transceiver starts the ARQ operation. In this case, the transceiver transmits/receives using the Data GID. During this period, the PF Ext. PTT (Data) port controls communication. The transceiver does not transmit the EOT after ending the transmission. When the DTC terminal becomes high, and when PF EXT. PTT (Data) Port becomes high, the EOT is sent and the ARQ operation finishes after the Data CH/GID Dwell Time expires.

The TOR port becomes low when the Data GID signal is received. When the external modem acknowledges the data receipt, the DTC terminal becomes low and the transceiver enters ARQ operation. When the PF Ext. PTT (Data) port is activated to transmit the ACK, the data transmission is made on the specified channel. In this case, the transceiver does not transmit the LTR data and the EOT.

17.7.2 Transceiver Operation When Using the ARQ Function with FleetSync

When the FleetSync initiates data transmission, the receiving party starts the ARQ operation. The transceiver does not transmit the EOT after ending the transmission. When the FleetSync Data communication is completed, the EOT is sent and ARQ operation ends.

The TOR port becomes low when the Data GID signal is received. When the transceiver acknowledges the data receipt in the FleetSync mode, the transceiver enters ARQ Mode. The transceiver does not perform the ACK response and the data transmission is made on the specified channel. In this case, the transceiver does not transmit the EOT.

18 SIGNALING

Signaling consists of Optional Signaling (DTMF, 2-tone and FleetSync) and the QT/DQT that performs selective call and Mute function control.

18.1 QT/DQT Decode/Encode

The QT/DQT is the signaling for facilitating communication within a Group when sharing the same channel with several Zones (Talk Group).

QT/ DQT cannot be heard from the speaker since it uses a sub-audible tone.

QT/DQT allows you to use the signaling in Conventional Group and the Squelch Tail Eliminator function. (Refer to [16 Conventional Group.](#))

The transceiver mutes unwanted calls when the QT/DQT for each Zone is configured. A user can communicate within a Talk Group without listening to conversations from other groups.

This signaling does not affect the voice communication since it does not use audible frequencies. The transceiver can distinguish the signaling since QT is a continuous wave form even if the reception starts midway.

Table 18-1 QT/DQT

QT	QT (Quiet Talk) uses a continuous sub-audible tone (67.0 - 254.1 [Hz]).
DQT	DQT (Digital Quiet Talk) uses a 23-bit signal (Code: 000 - 777 (hexadecimal). The DQT signal has polarity and can be configured as Normal or Inverse.

The following QT/DQT operation is available.

Table 18-2 QT/DQT Operation

Reception	When the received QT/DQT code matches the QT/DQT code configured in the transceiver, the receiving tone sounds. The tone mutes when the transceiver receives a Reverse Burst (QT) or Turn-off Code (DQT).
Transmission	The transceiver sends the QT/DQT code configured in the transceiver when the PTT switch is pressed. The transceiver continues sending the QT/DQT while either the PTT switch, the PF Data PTT port, the PF Ext. PTT (Voice) port, or the PF Ext. PTT (Data) port is pressed. You cannot send/receive the QT/ DQT in the Zone in Trunking system.

You can configure the QT/DQT Decode/Encode code to each channel using KPG-89D.

■ Configuration using KPG-89D

- Configuring the QT/DQT Decode (Refer to FPRG 6.3.5 QT/DQT Decode.)
- Configuring the QT/DQT Encode (Refer to FPRG 6.3.6 QT/DQT Encode.)

18.1.1 With STE (Squelch Tail Eliminator)

The Squelch Tail Eliminator in QT/DQT eliminates the noise factor from the transmitting party in order to communicate comfortably.

You can configure the Squelch Tail Eliminator function using KPG-89D.

■ Configuration using KPG-89D

- Configuring the w/STE function (Refer to FPRG 6.15.5 Modulation Line tab - w/STE.)

18.2 Optional Signaling

You can use the Optional Signaling to make an individual call. The transceiver emits the Alert Tone and starts the Transpond function when the configured Optional Signaling matches the received Optional Signaling.

You can use DTMF or FleetSync as the Optional Signaling. (Refer to [20 DTMF](#), [21 2-tone](#), [22 FleetSync.](#))

You can configure the Optional Signaling to each channel using KPG-89D.

■ Configuration using KPG-89D

- Configuring the Optional Signaling (Conventional Group) (Refer to FPRG 6.3.10 Optional Signaling.)
- Configuring the Optional Signaling (Trunking system) FPRG 6.6.7 Optional Signaling.)

18.3 Signaling (Audio Control)

This function allows you to configure the conditions to disable the Mute function using the QT/DQT or LTR ID and optional signaling. You can configure this function for each Zone.

18.3.1 Conventional Group

The transceiver disables the Mute function and emits sound when the configured conditions are satisfied.

You can configure the following conditions to unmute using KPG-89D. The transceiver performs the following operations

Table 18-3 Conditions to Disable the Mute Function and Operation of the Transceiver

Condition	Operation
QT/DQT	The QT/DQT disables the Mute function. The conditions to disable the Mute function do not affect the optional signaling. The conditions to disable the Mute function do not change even if the transceiver transmits.
QT/DQT or Optional Signaling	The QT/DQT disables the Mute function when the optional signaling is not matched. The Carrier Squelch function disables the Mute function when the optional signaling is matched. The conditions to disable the Mute function do not change even if the transceiver transmits.
QT/DQT and Optional Signaling	The Mute function is not disabled when the optional signaling is not matched. The QT/DQT disables the Mute function when the optional signaling is matched. The match status of the optional signaling resets after the transceiver enters Monitor Mode after transmission. The QT/DQT disables the Mute function after the transmission.

■ Configuration using KPG-89D

- Configuring the Signaling (Audio Control) (Refer to FPRG 6.2.6 Audio Control.)

18.3.2 Trunking System

The transceiver disables the Mute function and emits sound when the configured conditions are satisfied.

You can configure the following conditions to unmute using KPG-89D. The transceiver performs the following operations

Table 18-4 Conditions to Disable the Mute Function and Operation of the Transceiver

Condition	Operation
LTR ID	The LTR ID disables the Mute function. The conditions to disable the Mute function remain same even if the transceiver transmits.
LTR ID and Optional Signaling	You can perform Call Alert Beep, Call Alert, and Transpond functions when both the LTR ID and optional signaling match. When optional signaling matches, it remains in the match state until it is reset. After optional signaling matches, the transceiver controls the Mute function with the LTR ID match state. The match state of the optional signaling resets since the transceiver enters Monitor Mode after transmission. Therefore, the LTR ID disables the Mute function after the transceiver completes transmitting.

■ Configuration using KPG-89D

- Configuring the Signaling (Audio Control) (Refer to FPRG 6.5.10 Audio Control.)

18.4 Signaling (Decode)

This function allows you to configure how to decode the QT/DQT optional signaling. You can configure this function for each Zone.

18.4.1 Conventional Group

The transceiver decodes the optional signaling and starts performing the Call Alert Beep, Call Alert, and Transpond functions when the configured conditions are satisfied.

When optional signaling matches, it remains in the match status until it is reset.

You can configure the conditions to decode the optional signaling using KPG-89D. The transceiver performs the following operations

Table 18-5 Decode Conditions and Operation of the Transceiver

Condition	Operation
Carrier Decode	The transceiver decodes optional signaling regardless of QT/DQT status when detecting a Carrier.
QT/DQT Decode	The transceiver decodes optional signaling only when the QT/DQT is matched.

■ Configuration using KPG-89D

- Configuring the Signaling (Decode) (Refer to FPRG 6.2.5 Optional Signaling Decode Condition.)

18.4.2 Trunking System

The LTR ID must be matched in Trunking Systems. Therefore, the condition to decode the Signaling in Trunking system is the LTR ID Decode only.

The transceiver decodes the optional signaling and starts performing the Call Alert Beep, Call Alert, and Transpond functions when the optional signaling matches after it is decoded.

When optional signaling matches, it remains in the match state until it is reset.

18.5 Off-hook Decode

(TK-7180/ 8180 only)

This function allows a user to operate Carrier Squelch and release the Signaling and optional signaling in conjunction with the Mic hook status.

The Mute function is disabled regardless of the Mic hook status in the following conditions when the Off-hook Decode is enabled.

- The QT/DQT is matched.
- The optional signaling matches according to the Audio Control configuration.

You can enable/disable the Off-hook Decode function using KPG-89D.

Note:

- ◆ This function is available only in the TK-7180/ 8180.
- ◆ The Stun function is activated regardless of the Off-hook Decode function and the Mic hook status.
- ◆ The match state of the optional signaling resets when the Mic hook enters On-hook status after receiving the call with optional signaling.

■ Configuration using KPG-89D

- Configuring the Off-hook Decode (Refer to FPRG 6.7.1 Common-Page 1 tab - Off-hook Decode.)

18.6 Monitor

This function allows the transceiver to unmute and enter receive mode. The operation of this function varies between a Conventional Group and a Trunking system.

This function allows a user to monitor the channel before transmitting.

Press the **PF Monitor** key or the **PF Monitor Momentary** key when using this function.

■ Transceiver Operation

● PF Monitor key

- Press the **PF Monitor** key.

The “” appears.

The QT/DQT Signaling becomes inactive when the QT/DQT Decode function is configured to the channel and a user can hear the audio signal every time the transceiver receives a carrier.

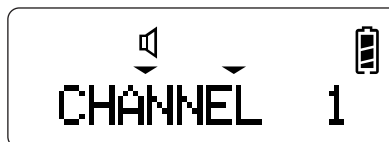

TK-2180/ 3180



TK-7180/ 8180

- Press the **PF Monitor** key.

The “” icon disappears.

If the QT/DQT is configured to the current channel, the transceiver returns to Signaling Squelch.

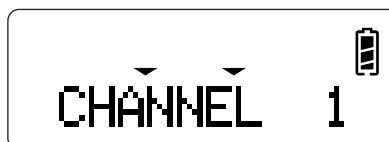

TK-2180/ 3180



TK-7180/ 8180

- **PF Monitor Momentary** key

1. Press the **PF Monitor Momentary** key.

The “🔊” appears while this key is pressed.

The QT/DQT Signaling becomes Inactive when the QT/DQT Decode function is configured to the channel and a user can hear audio every time the transceiver receives a Carrier.



TK-2180/ 3180



TK-7180/ 8180

2. Release the **PF Monitor Momentary** key.

The “🔊” icon disappears.

If the QT/DQT is configured to the current channel, the transceiver returns to Signaling Squelch.

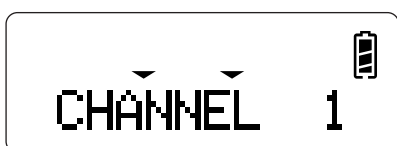

TK-2180/ 3180



TK-7180/ 8180

Note:

- ◆ When the **PF Monitor** key or the **PF Monitor Momentary** key is pressed, the optional signaling resets and it becomes active.
- ◆ In Trunking system, the transceiver does not disable the Mute function unless the ID matches even if it receives a Carrier. If the optional signaling is configured to the Group ID, the transceiver disables the Mute function only with the optional signaling.
- ◆ The status of the **PF Monitor** key is stored even if the transceiver is turned OFF.

■ Configuration using KPG-89D

- Assigning functions to the **PF** keys (Refer to FPRG 6.8 Key Assignment.)

18.6.1 Operations during Scan in Conventional Group

In Conventional Group, the transceiver mutes only with a carrier.

The “🔊” icon appears when the **PF Monitor** key is pressed during scan. The transceiver continues scan. The transceiver performs the Carrier Squelch function while the “🔊” icon appears.

The transceiver returns to the Carrier Squelch function when the **PF Monitor Momentary** key is pressed during scan. The transceiver does not stop scanning even if the **PF Monitor Momentary** key is pressed.

18.6.2 Operations during Scan in Trunking System

In Trunking system, the transceiver disables optional signaling and mutes only with the LTR ID.

The “🔊” icon appears when the **PF Monitor** key or the **PF Monitor Momentary** key is pressed during scan. The transceiver continues to scan.

18.7 Squelch

This function allows the transceiver to open Squelch and disable the Mute function.

With this function, the transceiver disables the Mute function without receiving a carrier. A user can use this function to monitor the channel before transmitting.

Press the **PF Squelch Off** key or the **PF Squelch Off Momentary** key to use this function.

■ Transceiver Operation

- **Squelch Off**

- Press the **PF Squelch Off** key.

The “🔊” icon appears. The BUSY LED lights green if the BUSY LED is configured.

The transceiver disables the Mute function and opens Squelch regardless of the QT/DQT Decode function. You can hear white noise if the transceiver has not received a Carrier.

The Squelch status of the transceiver becomes the same status as Squelch Level 0.



TK-2180/ 3180



TK-2180/ 3180



TK-7180/ 8180



TK-7180/ 8180

- Press the **PF Squelch Off** key.

The “” icon disappears. If the QT/DQT is configured to the current channel, the transceiver returns to the Signaling Squelch. Otherwise, the transceiver returns to the Carrier Squelch function.

- Release the **PF Squelch Off Momentary** key.

The “” icon disappears.

If the QT/DQT is configured to the current channel, the transceiver returns to the Signaling Squelch. Otherwise, the transceiver returns to the Carrier Squelch function.

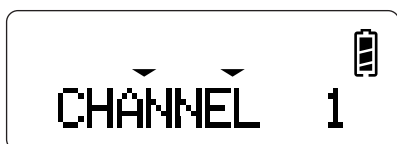

TK-2180/ 3180



TK-2180/ 3180



TK-7180/ 8180



TK-7180/ 8180

● Squelch Off Momentary

- Press and hold the **PF Squelch Off Momentary** key.

The “” icon appears. The BUSY LED lights green if the BUSY LED is enabled.

The transceiver disables the Mute function and the Squelch function regardless of the QT/DQT Decode function. You can hear the noise if the transceiver has not received a carrier.

The Squelch status of the transceiver becomes the same status as Squelch Level 0.

Note:

- ◆ When the **PF Squelch Off** key or the **PF Squelch Off Momentary** key is pressed, the optional signaling resets and it becomes active.
- ◆ In Trunking system, the transceiver does not disable the Mute function unless the ID matches even if it receives Carrier.
- ◆ The status of the **PF Squelch** key is stored even if the transceiver is turned OFF.

■ Configuration using KPG-89D

- Assigning functions to the **PF** keys (Refer to FPRG 6.8 Key Assignment.)

18.7.1 Operations during Scan in Conventional Group

The “” appears when the **PF Squelch Off** key is pressed during scan. The transceiver pauses scan and disables the Mute function. The transceiver when the **PF Squelch Off** key is pressed if it is not in receiving mode. The transceiver resumes scan after the Key Dwell Time expires if it is not in receiving mode.

The “” appears when the **PF Squelch Off Momentary** key is pressed during scan. The transceiver disables the mute function while the **PF Squelch Off Momentary** key is pressed. The transceiver mutes when the **PF Squelch Off Momentary** key is released. The transceiver resumes scan after the Key Dwell Time expires if it is not in receiving mode.

18.7.2 Operations during Scan in Trunking system

The “” icon appears when the **PF Squelch Off** key or the **PF Squelch Off Momentary** key is pressed during scan. The transceiver continues scan.

This function allows you to change the Decode/Encode combination of the QT/DQT Signaling without changing the transmit/receive frequencies.

This is used when there are several Talk Groups using QT/DQT codes on the same frequency.

You can configure a maximum of 40 pairs of OST QT/DQT Decode and QT/DQT Encode to the OST table. The QT/DQT Encode/Decode pair and the OST table are switched when the **PF OST** key is pressed.

You can configure the QT/DQT Decode/Encode pair for OST to each channel using KPG-89D.

Note:

- ◆ The OST is disabled when changing the Zone/Channel. The OST is enabled again when the transceiver returns to the Channel if the OST Status Memory is enabled. (Refer to 19.1 OST Status Memory.)
- ◆ When the OST and Talk Around functions are both activated, the OST function is executed first, as the Signaling operation.
- ◆ The OST List number appears on the Sub display when the "OST Number" is selected in **Optional Features** window > **Common-Page1** tab.

■ Transceiver Operation

● Enabling the OST Function

1. Press the **PF OST** key.
The OST Name appears for 2 seconds and the OST function is enabled.

● Disabling the OST Function

1. Press the **PF OST** key.
The OST function is disabled.

● Selecting the OST List

1. Press and hold the **PF OST** key for more than 1 second.
The transceiver enters List Selection Mode.
2. Select the OST List.
 - Common
Press **[B]**/ **[C]**.
 - TK-2180/ 3180 *1
Turn **Selector**.
 - TK-7180/ 8180 *1
[^]/ **[v]** key.
3. Select the OST and press **[S]**.
The selected OST becomes is enabled.

*1 The List Selection Key (Selector) is enabled.

■ Configuration using KPG-89D

- Assigning functions to the **PF** keys (Refer to FPRG 6.8 Key Assignment.)

19.1 OST Status Memory

This function allows a user to stack the OST code configured to each channel even if the transceiver is turned OFF or the channel is changed.

The OST function is disabled when the Channel is changed or the transceiver is turned OFF if this function is disabled.

You can enable/disable the OST Status Memory function using KPG-89D.

■ Configuration using KPG-89D

- Configuring the OST Status Memory (Refer to FPRG 6.7.4 Conventional tab - OST Status Memory.)

19.2 Tone Off

This function allows a user to select Tone Off in OST Mode.

You can disable the QT/DQT Encode/Decode.

You can enable/ disable the Tone Off function using KPG-89D.

■ Configuration using KPG-89D

- Configuring the Tone Off function (Refer to FPRG 6.7.4 Conventional tab - Tone Off.)

19.3 Direct OST

This function allows a user to select the OST using the keypad.

You can enable/disable this function using KPG-89D.

■ Transceiver Operation

1. Press and hold the [0] - [9] key for more than 1 second.

The OST Name appears for 2 seconds.

When the number of memories is less than 9, start from the step 3.

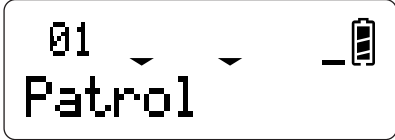

TK-2180/ 3180

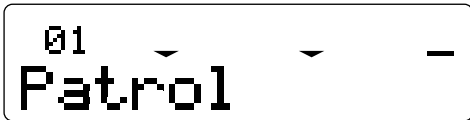

TK-7180/ 8180

2. Press and hold [*] for 1 second.

The transceiver enters List Number Selection Mode.

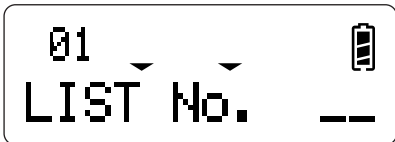

TK-2180/ 3180

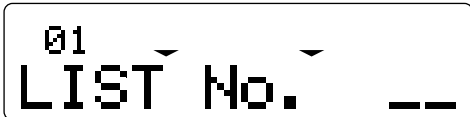

TK-7180/ 8180

3. Enter the OST List number.

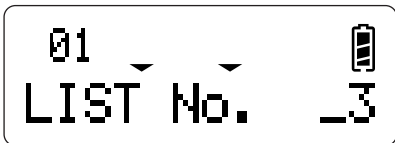

TK-2180/ 3180

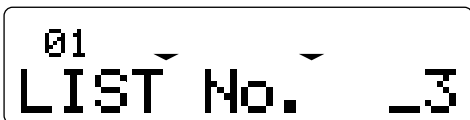

TK-7180/ 8180

The OST Name appears for 2 seconds.



TK-2180/ 3180



TK-7180/ 8180

The display returns to the channel display after 2 seconds.

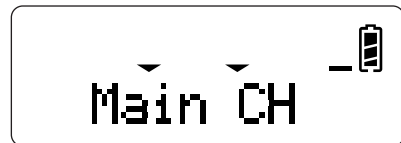

TK-2180/ 3180



TK-7180/ 8180

■ Configuration using KPG-89D

- Configuring the Direct OST function (Refer to FPRG 6.8.2 General Tab - Keypad Operation.)

19.4 OST Table

This function allows you to configure QT/DQT Decode/Encode pair for OST. You can configure a maximum of 40 pairs. You can configure the following functions in the OST Table.

Table 19-1 OST Table Configuration

OST Table	Function
OST Name	You can assign name to the OST QT/DQT Encode/Decode pair. You can enter a maximum of 12 characters. "TONE 1" - "TONE 40" appears when no OST Name is configured.
QT/DQT Decode	You can configure the QT/DQT Decode code. The following QT/DQT Decode range is available. QT: 67 - 254.1 Hz/ in steps of 0.1 Hz DQT: 000N - 777N, 000I - 777I
QT/DQT Encode	You can configure the QT/DQT to make a call. The following QT/DQT Encode range is available. QT: 67 - 254.1 Hz/ in steps of 0.1 Hz DQT: 000N - 777N, 000I - 777I

■ Configuration using KPG-89D

- Configuring a OST Name (Refer to FPRG 6.7.4 Conventional tab - OST Name.)
- Configuring the QT/DQT Decode (Refer to FPRG 6.7.4 Conventional tab - QT/DQT Decode.)
- Configuring the QT/DQT Encode (Refer to FPRG 6.7.4 Conventional tab - QT/DQT Encode.)

19.5 Standard QT

You can configure the 39 tones specified in EIA-603.

■ Configuration using KPG-89D

- Automatically configuring the Standard QT (Refer to FPRG 6.7.5. Conventional tab - Standard QT button.)

This transceiver supports DTMF (Dual Tone Multiple Frequency) as a signaling mode.

-DTMF signaling uses 2 different frequency tones simultaneously. You can use DTMF for PTT ID, an individual call, transmit a telephone number to the phone line, and remotely control the transceiver.

DTMF signaling uses 2 different frequencies (the high frequency and the low frequency) and consists of 0 - 9, A - D, * and # tone.

Table 20-1 DTMF Tone Frequency List

Low/High	1209 Hz	1336 Hz	1447 Hz	1633 Hz
697 Hz	1	2	3	A
770 Hz	4	5	6	B
852 Hz	7	8	9	C
941 Hz	*	0	#	D

20.1 Transmitting DTMF Tones

The following methods can be used to transmit the DTMF Tones.

- Manual Dialing
- Store & Send
- Keypad PTT
- Autodial List Selection

20.1.1 Manual Dialing

This function allows a user to transmit the DTMF Tones, while transmitting by pressing the **PTT** switch, when pressing [0] - [9], [*], and [#] on the Mic Keypad.

You can enable/disable the Manual Dialing function using KPG-89D.

■ Transceiver Operation

1. Press the **PTT** switch.
2. Press the key to transmit the DTMF tone.
The transceiver transmits the DTMF tone.
3. Repeat step 2 if necessary.

■ Configuration using KPG-89D

- Configuring the Manual Dialing (Refer to FPRG 6.10.1 Encode tab - Manual Dialing.)

20.1.2 Store & Send

This function allows a user to store an entered DTMF string using the Mic keypad, and then transmit it all at once. The user can send a string consisting of a maximum of 30 digits.

You can enable/disable this function using KPG-89D. Select "DTMF (Autodial)" using the Keypad Auto PTT to disable the **PF Autodial** key.

■ Transceiver Operation

● Using the Keypad

1. Press the **PF Autodial** key.
The Store & Send Entry display appears.
Select "DTMF (Autodial)" in **Key Assignment** window > **General** tab > **Keypad Operation** to disable the **PF Autodial** key.

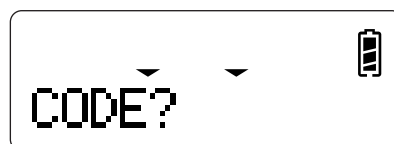

TK-2180/ 3180

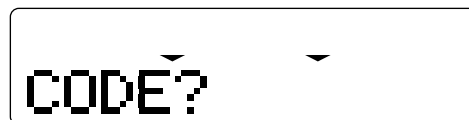

TK-7180/ 8180

2. Enter the DTMF code to send.
The entered code is confirmed.

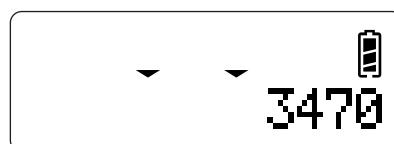

TK-2180/ 3180



TK-7180/ 8180

3. Repeat step 2 if necessary.



TK-2180/ 3180



TK-7180/ 8180

4. Press the **PTT** switch to make a voice call and send the DTMF code.

Press **[S2]** to send the DTMF code only.



TK-2180/ 3180



TK-7180/ 8180

The transceiver transmits the DTMF tone.



TK-2180/ 3180



TK-7180/ 8180

● **Without Using the Keypad**

1. Press the **PF Autodial** key.

The Store & Send Entry display appears.

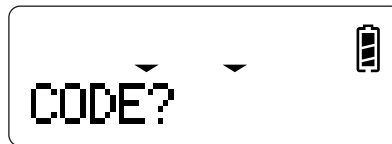

TK-2180/ 3180

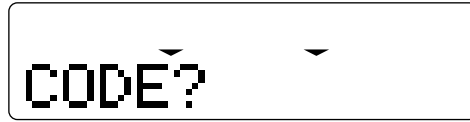

TK-7180/ 8180

2. Select a character using **Selector** or **[^]/[v]**.

The entered code appears on the display from the right end of the display, and the entering characters are blinking.



TK-2180/ 3180



TK-7180/ 8180

3. Press **[C]** when you complete entering the code.

The entered character stops blinking and confirmed on the display.



TK-2180/ 3180



TK-7180/ 8180

4. Repeat steps 2 and 3 if necessary.



TK-2180/ 3180



TK-7180/ 8180

5. Press the **PTT** switch to make a Voice call and send the DTMF code.

Press **[Side 2]/ [■]** to only send the DTMF code.



TK-2180/ 3180



TK-7180/ 8180

The transceiver transmits the DTMF tone.



TK-2180/ 3180



TK-7180/ 8180

■ Configuration using KPG-89D

- Configuring the Store & Send function (Refer to FPRG 6.10.1 Encode tab - Store & Send.)
- Configuring the List Selection Key (Selector) (Refer to FPRG 6.8.2 General Tab - List Selection Key (Selector).)

20.1.3 Keypad Auto PTT

This function allows you to transmit the DTMF Tones when pressing **[0] - [9]**, **[*]** and **[#]** on the Keypad.

You can enable/disable the Keypad Auto PTT function using KPG-89D.

Table 20-2 DTMF Tone Key Operation

Frequency	DTMF Digit
941.000 + 1336.000 Hz	DTMF tone "0"
697.000 + 1209.000 Hz	DTMF tone "1"
697.000 + 1336.000 Hz	DTMF tone "2"
697.000 + 1447.000 Hz	DTMF tone "3"
770.000 + 1209.000 Hz	DTMF tone "4"
770.000 + 1336.000 Hz	DTMF tone "5"
770.000 + 1447.000 Hz	DTMF tone "6"
852.000 + 1209.000 Hz	DTMF tone "7"
852.000 + 1336.000 Hz	DTMF tone "8"
852.000 + 1447.000 Hz	DTMF tone "9"
697.000 + 1633.000 Hz	DTMF tone "A"
770.000 + 1633.000 Hz	DTMF tone "B"
852.000 + 1633.000 Hz	DTMF tone "C"
941.000 + 1633.000 Hz	DTMF tone "D"
941.000 + 1209.000 Hz	DTMF tone "***"
941.000 + 1447.000 Hz	DTMF tone "#"

Note:

- ◆ Press and hold **[*]** for 1 second, then press **[2]** to enter the DTMF "A" tone.
- ◆ Press and hold **[*]** for 1 second, then press **[5]** to enter the DTMF "B" tone.
- ◆ Press and hold **[*]** for 1 second, then press **[8]** to enter the DTMF "C" tone.
- ◆ Press and hold **[*]** for 1 second, then press **[0]** to enter the DTMF "D" tone.
- ◆ Press **[*]** then press **[*]** again to enter the DTMF "***" tone.
- ◆ Press **[*]** then press **[#]** to enter the DTMF "#" tone.

■ Transceiver Operation

1. Press the key to transmit the DTMF tone.
The transceiver transmits the DTMF tone according to the selected key.
2. Repeat step 1 if necessary.

■ Configuration using KPG-89D

- Assigning functions to the **PF** keys (Refer to FPRG 6.8 Key Assignment.)

20.1.4 Autodial List Selection

This function allows a user to select the DTMF code registered in the Auto Dial Memory List and transmit it.

The user can use this function when the Store & Send function is disabled.

You can enable/disable the Store & Send function using KPG-89D.

■ Transceiver Operation

- Press the **PF Autodial** key.

The transceiver enters the Shortcut Entry Mode of the List Selection.

The minimum List number appears immediately after the transceiver is turned ON. Otherwise, the previously selected List number appears.

Select "DTMF (Autodial)" in **Key Assignment** window > **General** tab > **Keypad Operation** to disable the **PF Autodial** key.

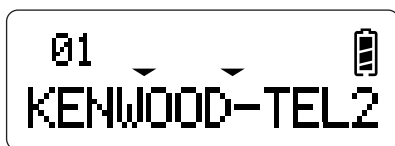

TK-2180/ 3180



TK-7180/ 8180

- Select the Autodial List.

- Common
Press **[B]/ [C]**.
- TK-2180/ 3180 *¹
Turn **Selector**.
- TK-7180/ 8180 *¹
Press **[^]/ [v]**.

*¹ When the List Selection Key (Selector) is enabled.

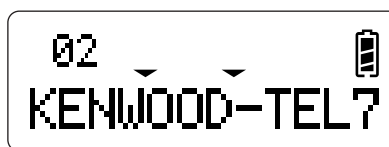

TK-2180/ 3180

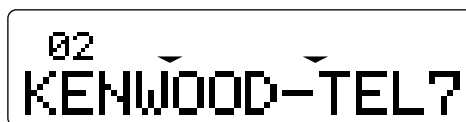

TK-7180/ 8180

- Press the **PTT** switch to make a voice call and send the DTMF code.

Press **[S2]** to send only the DTMF code.



TK-2180/ 3180



TK-7180/ 8180

■ Configuration using KPG-89D

- Configuring the Store & Send function (Refer to FPRG 6.10.1 Encode tab - Store & Send.)

20.1.5 Redial

This function allows a user to re-transmit the last transmitted DTMF code.

■ Transceiver Operation

- Press the **PF Autodial** key while the transceiver is in receiving mode.

The Autodial List display appears.

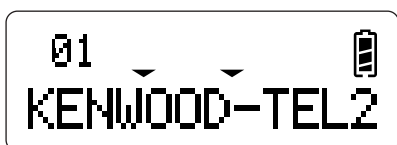

TK-2180/ 3180

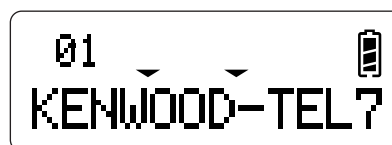

TK-2180/ 3180



TK-7180/ 8180



TK-7180/ 8180

2. Press **[*]** and **[0]**.

The previously transmitted DTMF code appears.
Press **[S]** to cancel transmitting the code.

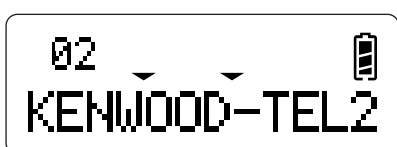

TK-2180/ 3180



TK-7180/ 8180

3. Press the **PTT** switch to make a voice call and send the DTMF code.
Press **[S2]** to send only the DTMF code.

20.1.6 Connect ID (BOT)

This function allows the transceiver to transmit the DTMF code configured to the Beginning of Transmit.

■ Transceiver Operation

1. Press the **PF Autodial** key while the transceiver is in receiving mode.
The Autodial List display appears.

2. Press **[*]** twice.

The DTMF code configured to the Beginning of Transmit appears.
Press **[S]** to cancel transmitting the code.

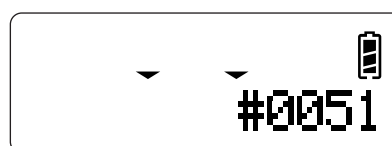

TK-2180/ 3180

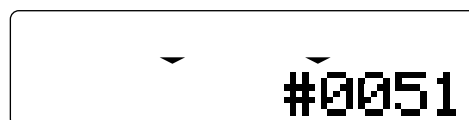

TK-7180/ 8180

3. Press the **PTT** switch to make a voice call and send the DTMF code.
Press **[Side 2]/ [■]** to only send the DTMF code.

20.1.7 Disconnect ID (EOT)

This function allows a user to transmit the DTMF code configured to the End of Transmit.

■ Transceiver Operation

1. Press the **PF Autodial** key while the transceiver is in receiving mode.
The Autodial List display appears.

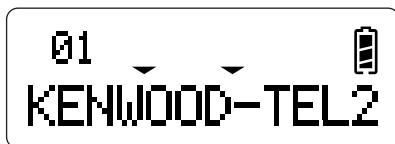

TK-2180/ 3180



TK-7180/ 8180

2. Press [*] and [#].

The DTMF code configured to the End of Transmit.
Press **[S]** to cancel transmitting the code.

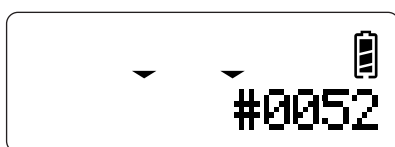

TK-2180/ 3180

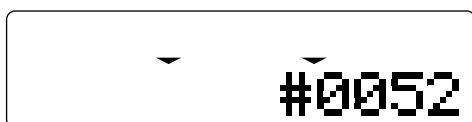

TK-7180/ 8180

3. Press the PTT switch to make a voice call and send the DTMF code.

Press **[Side 2]/ [■]** to only send the DTMF code.

20.2 Encode

You can configure the following functions that are linked to the DTMF Encode using KPG-89D.

- DTMF Speed
- First Digit Delay Time
- First Digit Time
- * and # Digit Time
- DTMF Hold Time
- D Code Assignment
- Sidetone
- Manual Dialing
- Store & Send
- Auto Telephone

20.2.1 DTMF Speed

You can configure the DTMF automatic transmission speed when automatically transmitting PTT ID, Autodial, Store & Send, BOT, or EOT.

You can select the DTMF automatic transmission speed (digit/sec) or configure the Digit Time.

You can configure the DTMF Speed using KPG-89D. The following speed is available to select the DTMF automatic transmission speed.

Table 20-3 DTMF Automatic Transmission Speed

Range	Digit Time (Transmission)	Gap Time (Silent)
6 Digit/s	83.3 ms	83.3 ms
8 Digit/s	62.5 ms	62.5 ms
10 Digit/s	50.0 ms	50.0 ms
15 Digit/s	33.3 ms	33.3 ms

■ Configuration using KPG-89D

- Configuring the DTMF Speed (Refer to FPRG 6.10.1 Encode tab - DTMF Speed.)

20.2.2 First Digit Delay Time

The First Digit Delay Time is the delay time between the time that the repeater begins the transmissions and the time that it ends the DTMF code transmission.

- Automatically transmitting the DTMF tone using PTT ID, Autodial, Store & Send, BOT, EOT, and Telephone Disconnect
- Transmitting the DTMF tone using the Keypad Auto PTT function

The transceiver performs the unmodulated transmission during the First Digit Delay Time.

You can configure the First Digit Delay Time using KPG-89D.

■ Configuration using KPG-89D

- Configuring the First Digit Delay Time (Refer to FPRG 6.10.1 Encode tab - First Digit Delay Time.)

20.2.3 First Digit Time

This function allows you to adjust the extension time for the transceiver to transmit the first digit of the DTMF string.

The period for the transceiver to transmit the first digit of the DTMF string can be obtained by adding the transmission time configured in the DTMF Speed to the First Digit Time.

This function ensures the recognition of the 1st DTMF digit even if the receiving party's transceiver is using the Power Saver function or performing scan.

You can configure the First Digit Time using KPG-89D.

■ Configuration using KPG-89D

- Configuring the First Digit Time (Refer to FPRG 6.10.1 Encode tab - First Digit Time.)

20.2.4 * and # Digit Time

The * and # Digit Time is the extension time for the transceiver to transmit the * Tone and # Tone of the DTMF string.

The period for the transceiver to transmit the * tone and # tone of the DTMF is obtained by adding the transmission time configuring the DTMF Speed to the * tone and # Digit Time.

When the first digit of the DTMF string is the * tone or the # Digit Time, the transceiver compares the extension time to transmit the first digit configured in the First Digit Time with the * and # Digit Time and uses the longer extension time to transmit.

You can configure the * and # Digit Time using KPG-89D.

■ Configuration using KPG-89D

- Configuring the * and # Digit Time (Refer to FPRG 6.10.1 Encode tab - * and # Digit Time.)

20.2.5 DTMF Hold Time

This function allows you to configure the unmodulated time before transmitting the DTMF tone using Keypad Auto PTT, from when the keypad is disabled to when the transceiver returns to receiving mode.

The receiving party's transceiver may translate the DTMF signal as one continuous string. The transceiver holds transmission when sending a continuous DTMF signal.

You can configure the DTMF Hold Time using KPG-89D.

■ Configuration using KPG-89D

- Configuring the DTMF Hold Time (Refer to FPRG 6.10.1 Encode tab - DTMF Hold Time.)

20.2.6 D Code Assignment

This function allows a user to select the D code to used as the D Code if the DTMF or Pause.

You can configure the D Code Assignment using KPG-89D.

■ Configuration using KPG-89D

- Configuring the D Code Assignment (Refer to FPRG 6.10.1 Encode tab - D Code Assignment.)

20.2.7 Sidetone

This function allows the transceiver to emit the DTMF transmission tone from the local speaker when sending the DTMF string.

You can enable/disable the DTMF Sidetone using KPG-89D.

Note: This function cannot be activated in Emergency Mode.

- The DTMF tone does not sound when Emergency Information/ Emergency Mode Type is "Silent" and Emergency Type is "DTMF".

■ Configuration using KPG-89D

- Configuring the DTMF Sidetone (Refer to FPRG 6.10.1 Encode tab - Sidetone.)

20.2.8 Manual Dialing

This function allows a user to transmit the DTMF tones, while transmitting by pressing the PTT switch, when pressing [0] - [9], [*], and [#] on the Mic Keypad.

You can enable/disable the Manual Dialing function using KPG-89D.

■ Configuration using KPG-89D

- Configuring the Manual Dialing (Refer to FPRG 6.10.1.Encode tab - Manual Dialing.)

20.2.9 Store & Send

This function allows a user to store entered DTMF codes using the Keypad, then transmit them at one time. You can send a DTMF string that consists of a maximum of 30 digits.

You can enable/disable the Store & Send function using KPG-89D.

■ Configuration using KPG-89D

- Configuring the Store & Send function (Refer to FPRG 6.10.1.Encode tab - Store & Send.)

20.2.10 Auto Telephone

You can enable/disable the Auto Telephone function. You can use this function when the [Side 2]/ [■] is pressed in Autodial Mode.

You can enable/disable the Auto Telephone function using KPG-89D.

■ Configuration using KPG-89D

- Configuring the Auto Telephone function (Refer to FPRG 6.10.1 Encode tab - Auto Telephone.)

20.3 Decode

You can configure the following functions that are linked to the DTMF Decoder using KPG-89D.

- Code
- Transpond/ Alert Tone
- Stun
- Auto Reset Timer
- Clear to Transpond
- Selective Call Alert LED

20.3.1 Code

Code is a standby code for an individual call.

The transceiver emits the Alert Tone and the Call Alert LED lights orange when the Code matches. A user can communicate only with the QT/DQT according to the selected operation in Decode Response.

■ Configuration using KPG-89D

- Configuring the Code (Refer to FPRG 6.10.2 Decode tab - Code.)

20.3.2 Transpond/ Alert Tone

The transceiver performs the Transpond/ Alert Tone function when the code matches. The selected operations in Transpond and Alert Tone is performed when the code matches.

You can configure Transpond/ Alert Tone using KPG-89D. Below is a list of configuration items for the Alert Tone and Transpond.

Table 20-4 Transpond/ Alert Tone Operation

Function	Operation
Alert Tone	The transceiver emits the configured Alert Tone.
Transpond	The transceiver performs the Transpond function. The transceiver overwrites the Transpond Tone and transmits it.

Note:

- The Alert Tone sounds after transponding when using the Transpond function and Alert Tone function at the same time.
- The Alert Tone is held since the channel is busy while configuring the Clear to Transpond operation.
- The Alert tone stops when any key is pressed while it is intermittently emitted if "Infinite" is selected in the **Special Alert Tone** window > Cycle edit box "Infinite". The received tone is preferred when the Alert Tone is intermittently emitted.
- The match status of DTMF resets in the following condition.

Table 20-5 Condition to Reset the DTMF Match State

Operation	Condition
Press a key.	One of the following keys is pressed. <ul style="list-style-type: none"> PF Monitor key PF Monitor Momentary key PF Squelch Off key PF Squelch Off Momentary key PF Zone Up key PF Zone Down key PF Zone Up/Down key PF CH/GID Up key PF CH/GID Down key PF CH/GID Up/Down key PF Scan key PF Home Channel key PF Direct CH/GID 1 - PF Direct CH/GID 5 key
On-hook	The microphone status becomes On-hook.
Timer expires.	Auto Reset Timer expires.
Code reception	Receiving Code + # code

- The status of Transpond resets in the following conditions.

Table 20-6 Condition to Reset the Transpond Status

Operation	Conditions
Press a key.	One of the following keys is pressed. <ul style="list-style-type: none"> PF Monitor key PF Monitor Momentary key PF Squelch Off key PF Squelch Off Momentary key PF Zone Up key PF Zone Down key PF Zone Up/Down key PF CH/GID Up key PF CH/GID Down key PF CH/GID Up/Down key PF Scan key PF Home Channel key PF Direct CH/GID 1 - PF Direct CH/GID 5 key
On-hook	The microphone status becomes On-hook.
Transmission	When transmitting using one of the following switch or ports. <ul style="list-style-type: none"> PTT switch PF Ext. PTT (Voice) port PF Ext. PTT (Data) port

■ Configuration using KPG-89D

- Configuring the Transpond (Refer to FPRG 6.10.2 Decode tab - Transpond.)
- Configuring the Alert Tone (Refer to FPRG 6.10.2 Decode tab - Alert Tone.)

20.3.3 Stun

Stun allows an administrator to remotely disable the transceiver, using the DTMF function.

The transceiver overwrites the Stun Code on Tone and starts Transpond function. Then, it performs the operation configured in the Stun Code Response.

The operation configured in the Stun Code Response is stored even if the transceiver is turned OFF. The conditions of the Stun Response resets only when receiving the Stun Reset code. It does not reset with the Auto Reset Timer or the transceiver's operation.

You can configure the Stun Code and Stun Code Response using KPG-89D.

Table 20-7 Stun Configuration

Operation	Conditions
Stun Code	The Stun Code is a standby code of the Stun function.

Operation	Conditions
Stun Code Response	Stun Response is the transceiver's response when the Stun Code matches. The following Stun Response operations are available. <ul style="list-style-type: none"> TX Inhibit: The transceiver inhibits transmission. Transceiver Inhibit: The transceiver cannot transmit and receive. Functions and operations of the transceiver are also inhibited. The transceiver emits the Warning Tone when the PTT switch is pressed. The Key-entry Error Tone sounds when a key other than the PTT switch is pressed.

Note:

- ◆ The transceiver does not enter Emergency Mode when the Stun function is enabled.
- ◆ The transceiver does not automatically send the GPS data when the Stun function is enabled.

■ Configuration using KPG-89D

- Configuring the Stun Code (Refer to FPRG 6.10.2 Decode tab - Stun Code.)
- Configuring the Stun Response (Refer to FPRG 6.10.2 Decode tab - Stun Response.)

20.3.4 Auto Reset Timer

The Auto Reset Timer is the duration from the time when communication ends to the time when the DTMF match state is reset.

You can configure the Auto Reset Timer using KPG-89D. You can also configure the operation after the Auto Reset Timer expires.

Table 20-8 Operation after the Auto Reset Timer Expires.

Auto Reset Timer	Operation
Disable	The Auto Reset Timer does not work.
LED	The orange Selective Call Alert LED stops blinking when the Auto Reset Timer expires.
Alert	The intermittently emitted Alert Tone stops when the Auto Reset Timer expires.
Monitor	The match status of the DTMF resets when the Auto Reset Timer expires.

■ Configuration using KPG-89D

- Configuring the Auto Reset Timer (Refer to FPRG 6.10.2 Decode tab - Auto Reset Timer.)

20.3.5 Clear to Transpond

This function allows the transceiver to wait before performing the Transpond function until the channel is released by another user.

You can enable/disable the Clear to Transpond function using KPG-89D.

Note: This function works only in Conventional Group.

■ Configuration using KPG-89D

- Configuring the Clear to Transpond (Refer to FPRG 6.10.2 Decode tab - Clear to Transpond.)

20.3.6 Selective Call Alert LED

This function makes the SelCall Alert LED blink when receiving a code.

This function allows a user to monitor a call when he/she is away from the transceiver.

You can enable/disable the Selective Call Alert LED using KPG-89D. (Refer to 22.2 Selective Call Function.)

■ Configuration using KPG-89D

- Configuring the Selective Call Alert LED (Refer to FPRG 6.10.2 Decode tab - Selective Call Alert LED.)

20.4 Autodial

You can configure the following functions that are linked to Autodial using KPG-89D.

- Autodial List
- Autodial Programming

20.4.1 Autodial List

This function allows you to configure the DTMF code used in Autodial function.

You can configure the Autodial List using KPG-89D. Below is a list of configuration items for the Autodial List.

Table 20-9 Table 20-9 Autodial List Configuration

Autodial List	Operation
Name	You can assign a name to the DTMF code. You can enter a maximum of 12 characters.
Code	You can enter the DTMF code to send. You can enter a maximum of 16 digit numbers.

■ Configuration using KPG-89D

- Configuring the Name (Refer to FPRG 6.10.3 Auto Dial List tab - DTMF Name.)
- Configuring the Code (Refer to FPRG 6.10.3 Auto Dial List tab - Code.)

20.4.2 Autodial Programming

This function allows you to configure, change, or delete the DTMF Autodial List using the **PF** keys.

You can change the Name and the DTMF code by pressing the **PF Autodial Programming** key.

You can enable/disable the Autodial Programming function using KPG-89D.

Note: The key is activated as below when the List name or the DTMF code is entered.

Table 20-10 Key Operation

Key Name	Operation
Selector/ [^]/ [v]	Up/Down of the entered channel
[Side 1]/ [^]	Exit Mode.
[S]	Move to next item.
[A]	Press: Delete a number. Hold: Delete all numbers.
[B]	
[C]	Confirm the entered character.
[Side 2]/ [■]	
[0]	(Space)/ 0
[1]	1
[2]	A/ B/ C/ 2
[3]	D/ E/ F/ 3
[4]	G/ H/ I/ 4
[5]	J/ K/ L/ 5
[6]	M/ N/ O/ 6
[7]	P/ Q/ R/ S/ 7
[8]	T/ U/ V/ 8
[9]	W/ X/ Y/ Z/ 9
[*]	Confirm the entered character.
[#]	Press: Delete a number. Hold: Delete all numbers.
PTT switch	Exit PTT Mode and transmit.

■ Transceiver Operation

● Configuring/modifying the Autodial List

1. Press the PF Autodial Programming key.

The first List number appears. No List number appears when the Autodial List is not configured.

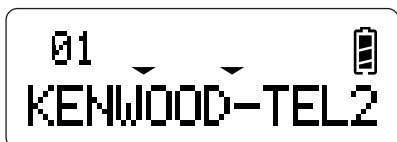

TK-2180/ 3180



TK-7180/ 8180

2. Select the Autodial List to configure.

The number in the list appears on the sub display.

- Common
Press **[B]**/**[C]**.
- TK-2180/ 3180 ^{*1}
Turn **Selector**.
- TK-7180/ 8180 ^{*1}
Press **[^]**/**[v]**.

^{*1} When the List Selection Key (Selector) is enabled.

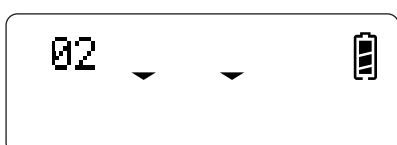

TK-2180/ 3180



TK-7180/ 8180

3. Press **[S]** or **[*]**.

The List number is confirmed.

4. Select the List name using **Selector**, **[Up]**/**[Down]**, or Keypad.

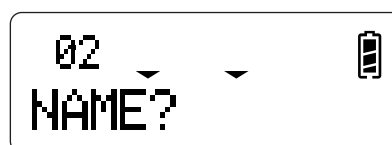

TK-2180/ 3180



TK-7180/ 8180

5. Press **[S]** when you complete entering characters.

The Autodial List Name is confirmed.

6. Enter the DTMF code using **Selector**, **[Up]**/**[Down]**, or Keypad.

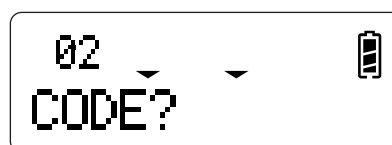

TK-2180/ 3180



TK-7180/ 8180

7. Press **[S]** when you complete entering the code.

The writing completion message appears.

"STORE?" appears when no data exists on the memory.

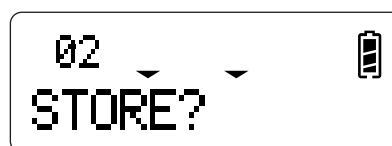

TK-2180/ 3180



TK-7180/ 8180

“OverWrt?” appears when data exists in the memory.

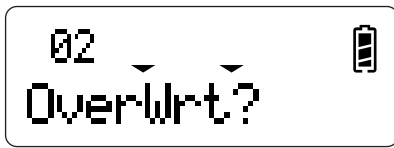

TK-2180/ 3180



TK-7180/ 8180

3. Press **[A]** or **[#]** after selecting the List.
“DELETE?” appears on the display.



TK-2180/ 3180



TK-7180/ 8180

8. Press **[S]** or **[*]**.

The data is written and the **Autodial List Selection** window appears.

4. Press **[S]** or **[*]**.

The Autodial List is deleted.

● **Deleting the Autodial List**

1. Press the **PF Autodial Programming** key.

The first Auto Dial List number appears. No List number appears when the Autodial List is not configured.

■ **Configuration using KPG-89D**

- Assigning functions to the **PF** keys (Refer to FPRG 6.8 Key Assignment.)

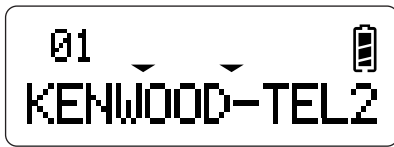

TK-2180/ 3180



TK-7180/ 8180

2. Select the Autodial List number to delete.

- Common
Press **[B]/ [C]**.
- TK-2180/ 3180 *1
Turn **Selector**.
- TK-7180/ 8180 *1
Press **[^]/ [v]**.

*1 When the List Selection Key (Selector) is enabled.

21 2-TONE

The transceiver supports 2-tone signaling.

2-tone is a pair of 2 different tones. A user can use 2-tone signaling to make an individual call.

The 2-tone signalling is a series of different tones (or one tone) having frequencies between 288.5 and 3106.0 Hz.

Note: This function is available only in Conventional Group.

21.1 Transmitting 2-tone

A user can transmit 2-tone in a Conventional Group. The user can select the Encode Tone from the Encode Memory List by pressing the **PF 2-tone** key. Press the **PTT** switch after selecting the tone to transmit.

■ Transceiver operation

1. Press the **PF 2-tone** key.

The minimum List number appears immediately after the transceiver is turned ON. Otherwise, the previously selected List number appears.



TK-2180/ 3180



TK-7180/ 8180

2. Select the 2-tone Encode List.

- Common
Press **[B]**/ **[C]**.
- TK-2180/ 3180 *¹
Turn **Selector**.
- TK-7180/ 8180 *¹
Press **[^]**/ **[v]**.

*¹ When the List Selection Key (Selector) is enabled.



TK-2180/ 3180



TK-7180/ 8180

3. Press the **PTT** switch to make a voice call and transmit the 2-tone Encode Tone.

Press **[S2]** to transmit only the 2-tone Encode Tone.



TK-2180/ 3180



TK-7180/ 8180

21.2 Encode

You can configure the following functions that are linked to the 2-tone Encode in KPG-89D.

- Duration of 1st Tone
- Duration of 2nd Tone
- Duration of Single Tone
- Gap Time
- First Tone Delay Time
- Sidetone
- 2-tone Encode Memory List

21.2.1 Duration of 1st Tone

This function allows you to configure the 1st Tone Encode configured in the 2-tone Encode Memory List.

You can configure the Duration of 1st Tone using KPG-89D. Normally, configure this duration to 1 second.

■ Configuration using KPG-89D

- Configuring the Duration of 1st Tone (Refer to FPRG 6.11.1 Encode tab - Duration of 1st Tone.)

21.2.2 Duration of 2nd Tone

This function allows you to configure the 2nd Tone Encode transmit configured in the 2-tone Encode Memory List.

You can configure the Duration of 2nd Tone using KPG-89D. Normally, configure this duration to 3 seconds.

■ Configuration using KPG-89D

- Configuring the Duration of 2nd Tone (Refer to FPRG 6.11.1 Encode tab - Duration of 2nd Tone.)

21.2.3 Duration of Single Tone

This function allows you to configure the Single Tone Encode transmit time configured in the 2-tone Encode Memory List.

You can configure the Duration of Single Tone using KPG-89D. Normally, configure this duration to 5 seconds.

■ Configuration using KPG-89D

- Configuring the Duration of Single Tone (Refer to FPRG 6.11.1 Encode tab - Duration of Single Tone.)

21.2.4 Gap Time

This function allows you to configure the unmodulated carrier time between the 1st Tone and the 2nd Tone configured in the 2-tone Encode Memory List is transmitted.

You can configure the Gap Time using KPG-89D. Normally, configure this period to 0 ms.

■ Configuration using KPG-89D

- Configuring the Gap Time (Refer to FPRG 6.10.1 Encode tab - Gap Time.)

21.2.5 First Tone Delay Time

The First Digit Delay Time is the delay time between the time that the transceiver begins transmission and the time that it ends the 2-tone transmission. The unmodulated transmission is performed during the First Digit Delay Time.

You can configure the First Tone Delay Time using KPG-89D.

■ Configuration using KPG-89D

- Configuring the First Tone Delay Time (Refer to FPRG 6.10.1 Encode tab - First Tone Delay Time.)

21.2.6 Sidetone

This function allows the transceiver to monitor the 2-tone transmission from the local speaker.

You can configure the 2-tone sidetone using KPG-89D.

■ Configuration using KPG-89D

- Configuring the Sidetone (Refer to FPRG 6.11.1 Encode tab - Sidetone.)

21.2.7 2-tone Encode Memory List

This is the code list for performing the 2-tone Encode operation. The transceiver transmits the 2-tone when the code configured in this list is selected.

You can configure the following functions in the 2-tone Encode Memory List.

Table 21-1 Autodial List Configuration

Autodial List	Operation
Single Tone	This function allows you to configure the transmission code as a Single Tone. You cannot configure the 2nd Tone when configuring the transmission code as a Single Tone.
2-tone Name	This function allows you to assign a name to each List number. You can configure a maximum of 12 characters to each number.
1st Tone	This function allows you to configure the 1st Tone frequency. You can configure the frequency between 288.5 and 3106.0 Hz.
2nd Tone	This function allows you to configure the 2nd Tone frequency. You can configure the frequency between 288.5 and 3106.0 Hz. You cannot configure the 2nd Tone when configuring the transmission code as a Single Tone.

■ Configuration using KPG-89D

- Configuring the Single Tone (Refer to FPRG 6.11.1 Encode tab - Single Tone.)
- Configuring a 2-tone Name (Refer to FPRG 6.11.1 Encode tab - 2-tone Name.)
- Configuring the 1st Tone (Refer to FPRG 6.11.1 Encode tab - 1st Tone.)
- Configuring the 2nd Tone (Refer to FPRG 6.11.1 Encode tab - 2nd Tone.)

21.3 Decode

There are four signaling options for each channel in the Conventional Group: 2-tone 1, 2-tone 2, 2-tone 3, and 2-tone 4.

You can configure the following functions to 2-tone 1, 2-tone 2, 2-tone 3, and 2-tone 4.

- Decoder 1 - 4
- A Tone/B Tone/C Tone/D Tone
- Auto Reset Timer
- Clear to Transpond
- Selective Call Alert LED

21.3.1 Decoder 1 - 4

You can configure 4 types of Decoders for each of 2-tone 1, 2-tone 2, 2-tone 3, and 2-tone 4. The transceiver can receive the 2-tone Code configured to Decoder 1 - 4 at the same time.

You can configure the following functions to each Decoder.

■ Call Format

This function allows a user to select the A Tone, B Tone, C Tone, and D Tone combination. The following combinations are available.

Table 21-2 Format Combination List

Combination	Combination Pattern	Standby
1	<ul style="list-style-type: none"> • A-B (The transceiver waits for receiving A Tone and B Tone.) • A-C (The transceiver waits for receiving A Tone and C Tone.) • A-D (The transceiver waits for receiving A Tone and D Tone.) 	The transceiver stands by for the First Tone for 1 second and the Second Tone for 3 seconds.
2	<ul style="list-style-type: none"> • B-A (The transceiver waits for receiving B Tone and A Tone.) • B-C (The transceiver waits for receiving B Tone and C Tone.) • B-D (The transceiver waits for receiving B Tone and D Tone.) 	
3	<ul style="list-style-type: none"> • C-A (The transceiver waits for receiving C Tone and A Tone.) • C-B (The transceiver waits for receiving C Tone and B Tone.) • C-D (The transceiver waits for receiving C Tone and D Tone.) 	
4	<ul style="list-style-type: none"> • D-A (The transceiver waits for receiving D Tone and A Tone.) • D-B (The transceiver waits for receiving D Tone and B Tone.) • D-C (The transceiver waits for receiving D Tone and C Tone.) 	
5	• Long A (The transceiver waits for receiving A Tone.)	The transceiver stands by for the First Tone for 5 seconds.
6	• Long B (The transceiver waits for receiving B Tone.)	
7	• Long C (The transceiver waits for receiving C Tone.)	
8	• Long D (The transceiver waits for receiving D Tone.)	

■ Transpond/ Alert Tone

You can configure the operation of the transceiver when it receives a call using 2-tone signaling.

Table 21-3 Transpond/ Alert Tone Operation

Transpond	Alert	Operation
No	Off	The transceiver does not perform any operation.

21 2-TONE

Transpond	Alert	Operation
Yes	Off	The transceiver transmits the Transpond Tone.
No	Other than Off	The transceiver transmits the Alert Tone.
Yes	Other than Off	The transceiver transmits the Alert Tone after it transmits the Transpond tone.

■ Alert Tone

You can configure the Alert Tone to transmit when the transceiver receives a call using 2-tone signaling.

You can select one of eight tone patterns configured in the Alert Tone Pattern. ([Refer to 4.7 Alert Tone Pattern.](#))

■ Configuration using KPG-89D

- Configuring the Call Format (Refer to FPRG 6.10.2 Decode tab - Call Format.)
- Configuring the Transpond function (Refer to FPRG 6.11.2 Decode tab - Transpond.)
- Configuring the Alert Tone (Refer to FPRG 6.11.2 Decode tab - Alert Tone.)

21.3.2 A Tone/ B Tone/ C Tone/ D Tone

This function allows you to configure the frequency of the tones. You can configure the frequency between 288.5 and 3106.0 Hz.

■ Configuration using KPG-89D

- Configuring the A Tone/ B Tone/ C Tone/ D Tone (Refer to FPRG 6.11.2 Decode tab - A Tone/ B Tone/ C Tone/ D Tone.)

21.3.3 Auto Reset Timer

The Auto Reset Timer is the duration from the time when communication ends to the time when the 2-tone match status is reset.

You can configure the Auto Reset Timer using KPG-89D. You can also configure the operation after the Auto Reset Timer is expired.

Table 21-4 Operation after the Auto Reset Timer is expired.

Auto Reset Timer	Operation
Off	The Auto Reset Timer does not work.
LED indicator	The orange Selective Call Alert LED stops blinking when the Auto Reset Timer expires.
Alert	The intermittent transmission of the Alert Tone stops when the Auto Reset Timer expires.

Auto Reset Timer	Operation
Monitor	The match status of the DTMF resets when the Auto Reset Timer expires.

■ Configuration using KPG-89D

- Configuring the Auto Reset Timer (Refer to FPRG 6.11.2 Decode tab - Auto Reset Timer.)
- Configuring the LED (Refer to FPRG 6.11.2 Decode tab - LED.)
- Configuring the Alert (Refer to FPRG 6.11.2 Decode tab - Alert)
- Configuring the Monitor function (Refer to FPRG 6.11.2 Decode tab - Monitor.)

21.3.4 Clear to Transpond

This function prevents the transceiver from performing the Transpond function until the channel becomes available.

You can enable/disable the Clear to Transpond function using KPG-89D.

■ Configuration using KPG-89D

- Configuring the Clear to Transpond (Refer to FPRG 6.11.2 Decode tab - Clear to Transpond.)

21.3.5 Selective Call Alert LED

This function makes the SelCall Alert LED blink when the code is received.

You can enable/disable the Selective Call Alert LED using KPG-89D. ([Refer to 22.2 Selective Call Function.](#))

Note:

- ◆ The match status of 2-tone resets in the following conditions.

Table 21-5 Condition to reset the 2-tone Match Status

Operation	Condition
Press a key.	One of the following keys is pressed. <ul style="list-style-type: none"> • PF Monitor key • PF Monitor Momentary key • PF Squelch Off key • PF Squelch Off Momentary key • PF Zone Up key • PF Zone Down key • PF Zone Up/Down key • PF CH/GID Up key • PF CH/GID Down key • PF CH/GID Up/Down key • PF Scan key • PF Home CH/GID key • PF Direct CH/GID 1 - PF Direct CH/GID 5 key
On-hook	The microphone status becomes On-hook.

Operation	Condition
Timer expires.	Auto Reset Timer expires.

- ◆ The status of Transpond resets in the following conditions. This Transpond code is held when the transmission is disabled with the Busy Channel Lockout function.

Table 21-6 Condition to Reset the Transpond Status

Operation	Condition
Press a key.	One of the following keys is pressed. <ul style="list-style-type: none"> • PF Monitor key • PF Monitor Momentary key • PF Squelch Off key • PF Squelch Off Momentary key • PF Zone Up key • PF Zone Down key • PF Zone Up/Down key • PF CH/GID Up key • PF CH/GID Down key • PF CH/GID Up/Down key • PF Scan key • PF Home CH/GID key • PF Direct CH/GID 1 - PF Direct CH/GID 5 key
On-hook	The microphone status becomes On-hook.
Transmission	When transmitting using one of the following devices. <ul style="list-style-type: none"> • PTT switch • PF Ext. PTT (Voice) port • PF Ext. PTT (Data) port

■ Configuration using KPG-89D

- Configuring the Selective Call Alert LED (Refer to FPRG 6.11.2 Decode tab - Selective Call Alert LED.)

FleetSync, developed by Kenwood, utilizes MSK (Minimum Shift Keying) modulation to exchange data between transceivers. It identifies individual transceivers, and allows for text messages and GPS data communications.

You can also connect the transceiver to a PC or external devices since FleetSync supports serial data communication.

22.1 PTT ID Function

PTT ID is the function to transmit an identification code when making a call.

A user can view the caller's ID with the received PTT ID. The user can confirm the caller not only by voice, but also through the display.

You can configure the PTT ID for each CH/GID. The PTT ID is transmitted in the following timing. (Refer to 14 PTT ID.)

Table 22-1 Timing To Transmit the PTT ID

PTT ID	Timing To Transmit the PTT ID
Off	The PTT ID is not transmitted.
BOT	You can transmit Fleet (Own) and ID (Own) as the PTT ID when pressing the PTT switch or the PF Ext. PTT (Voice) port.
EOT	You can transmit Fleet (Own) and ID (Own) as the PTT ID when releasing the PTT switch or the PF Ext. PTT (Voice) port.
Both	You can transmit Fleet (Own) and ID (Own) as the PTT ID when pressing/releasing the PTT switch or the PF Ext. PTT (Voice) port.
List 1 - 100	You can call the receiving party's PTT ID. You can select the ID from 1 to 100 in SelCall list. You can make a SelCall with the Fleet and the ID.

Note:

- ◆ You can only select the ID configured in FleetSync > ID List for List 1 - 100.
- ◆ The PTT ID is transmitted to make a voice communication. The PTT ID is not transmitted when transmitting with the PF Data PTT port and the PF Ext. PTT (Data) port.

■ Configuration using KPG-89D

- Configuring the PTT ID (Channel) (Refer to FPRG 6.3.12 PTT ID.)
- Configuring the PTT ID (Group ID) (Refer to FPRG 6.6.8 PTT ID.)

22.1.1 Caller ID Display

This function allows you to display the received PTT ID on the LCD.

A user can confirm the caller not only by voice, but also through the display.

"CID" appears on the sub display when the transceiver receives a PTT ID. The display returns to the channel display after the Auto Reset Timer expires if the Auto Reset Timer is configured. The display returns to normal when pressing a key.

The ID is displayed when a PTT ID is received even when the conditions for disabling the Mute function are not satisfied.

You can configure the receive PTT ID to be displayed using KPG-89D.

Note:

- ◆ You cannot reply to the ID displayed on the display.
- ◆ The PTT ID is displayed when receiving BOT or EOT.

■ Configuration using KPG-89D

- Configuring the Caller ID Display (Refer to FPRG 6.12.1 General 1 tab - Sub Display.)

22.1.2 PTT ID Sidetone

This tone sounds when the caller transmits the FleetSync ID. This tone notifies the user of when the conversion is possible after the **PTT** switch or the PF Ext. PTT (Voice) port is pressed.

This function prevents the transceiver from missing calls by starting the conversion during FleetSync PTT ID transmission.

You can enable/disable this function using KPG-89D.

Note: When the PTT ID is configured to the channel, the Proceed Tone is disabled.

■ Configuration using KPG-89D

- Configuring the PTT ID Sidetone (Refer to FPRG 6.12.1 General 1 tab - PTT ID Sidetone.)

22.2 Selective Call Function

This function allows you to make a call using the FleetSync ID.

You can make a call with your own FleetSync ID and the receiving party's ID by pressing the **PTT** switch or the **PF Ext. PTT (Voice)** port after selecting the receiving party's ID. The transceiver unmutes when the receiving party receives the FleetSync ID.

The caller's ID appears on the receiving party's transceiver. The receiving party can respond to the caller by pressing the **PTT** switch or the **PF Ext. PTT (Voice)** port while the caller's ID is displayed.

Following Selective Call types are available.

Table 22-2 Selective Call Type

Call Type	Description
Individual Call	This function is used to make a call to the specified transceiver. The transceiver acknowledges that the received call is the Individual Call when receiving the Selective Call having the Fleet and the Unit ID matching your own ID.
Group Call	This function is used to make a call to several transceivers in the specified Fleet. The transceiver acknowledges that the received call is the Group Call when receiving the Selective Call having the Unit ID configured to "Unit ID" and the same Fleet.
Fleet Call	This function is used to make a call to the party having the FleetSync ID within the same Fleet. The transceiver acknowledges that the received call is the Fleet Call when receiving the Selective Call having the Unit ID configured to "0 (ALL)" and the same Fleet.
Supervisor Call	This function is used to make a call to the party having the same Unit ID in each Fleet. The transceiver acknowledges that the received call is the Supervisor Call when receiving the Selective Call having the Fleet configured to "0 (ALL)" and the same Unit ID.
Broadcast Call	This function is used to make a call to all transceivers having the FleetSync ID. The transceiver acknowledges that the received call is the Broadcast Call when receiving the Selective Call having the Unit ID configured to "0 (ALL)" and the Fleet configured to "0 (ALL)".

22.2.1 Making a Selective Call

A user can make a Selective Call by selecting the party from the List or using the Manual Dialing function.

The user can make a Selective Call by selecting the FleetSync ID registered in the FleetSync ID List. (Refer to [22.2.3 ID List](#).)

With the Manual Dialing function, the user can make a Selective Call by directly specifying the FleetSync ID. The call type is decided according to the number of the entered digits.

Table 22-3 Call Type in Manual Dialing

Entered Digit Number	Range	Call Type
7-digit ffffiii	The transceiver recognizes the entered value as Fleet and ID. fff: Fleet: 100 - 349 iiii: ID: 1000 - 4999	Individual Call
4-digit iiii	The transceiver recognizes the entered value as the ID. iiii: ID: 1000 - 4999	Individual Call/ Group Call
3-digit fff	The transceiver recognizes the entered value as the Fleet fff: Fleet: 100 - 349	Fleet Call

A user can use the Paging Call function to make a Selective Call. This function allows the user to call to the party without communications with the party.

Note:

- ◆ The Auto Reply Message function does not activate with Paging Calls.
- ◆ A user can make a Supervisor Call only when selecting the party from the List.

■ Transceiver Operation

● Making a Selective Call with the List Selection:

1. Press the **PF Selcall** key or the **PF Selcall + Status** key.

The transceiver enters List Selection Mode.

The last used ID Name appears on the display.

The lowest number in the ID List appears on the display at first when the transceiver enters List Selection Mode.



TK-2180/ 3180

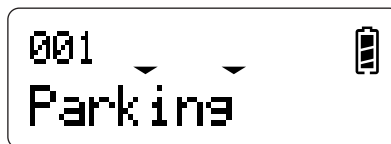

TK-2180/ 3180



TK-7180/ 8180



TK-7180/ 8180

2. Select the List number.

- Common
Press **[B]**/**[C]** to increase/decrease the List number.
- TK-2180/ 3180 ^{*1}
Turn **Selector** clockwise to increase the List number.
Turn **Selector** counterclockwise to decrease the List number.
- TK-7180/ 8180 ^{*1}
Press **[^]**/**[v]** to increase/decrease the List number.

^{*1} When the List Selection Key (Selector) is enabled.



TK-2180/ 3180

2. Press and hold **[S]** or **[*]** for more than 1 second.

The transceiver enters Selcall ID Entry Mode.
The last used ID appears on the display.
No ID appears on the display when the transceiver enters Selcall ID Entry Mode for the first time.

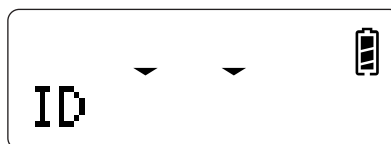

TK-2180/ 3180

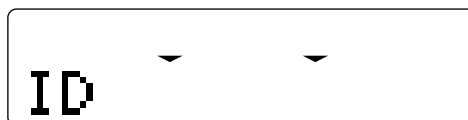

TK-7180/ 8180



TK-7180/ 8180

3. Enter the ID.

- **Using Selector or PF keys ^{*2}**
 - Select the character using **Selector** or **PF Up/Down** keys.
 - Press **[C]** after entering the ID.

^{*2} When the List Selection Key (Selector) is enabled.

3. Press the **PTT** switch to make a voice call.

Press **[S2]** to make a paging call.
Press **[S]** to enter the Status Message. (Only when the transceiver enters Status Message Entry Mode using the **PF Selcall + Status** key.)

• **Making a Selective Call with the Manual Dialing function:**

1. Press the **PF Selcall** key or the **PF Selcall + Status** key.
The transceiver enters List Selection Mode.

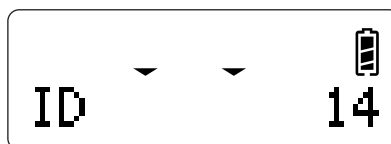

TK-2180/ 3180



TK-7180/ 8180

- **Using the Keypad**
 - Enter the ID using [0] - [9].
- **Deleting the entered character**
 - Press [A] - [#].
The selected character is deleted.
 - Press and hold [A] - [#].
All characters are deleted.

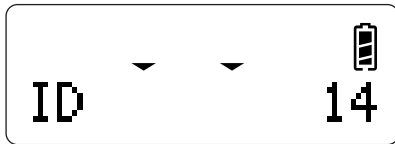

TK-2180/ 3180



TK-7180/ 8180

4. Press the **PTT** switch to make a voice call.
Press **[Side 2]/ [■]** to make a paging call.
Press **[S]** to enter the Status Message. (Only when the transceiver enters Status Message Entry Mode using the **PF Selcall + Status** key.)
(Refer to [22.3 Status Message Function](#).)

22.2.2 Receiving a Selective Call

The transceiver enters the Reception Display Mode when receiving a Selective Call.

The condition for the FleetSync ID to match is as follows.

Table 22-4 Call TypeConditions to Unmute

Call Type	Conditions to Unmute	
	Fleet fff: 100 - 399	ID iiii: 1000 - 4999
Individual Call	Match	Match
Group Call	Match	Group ID matches.
Fleet Call	Match	ALL ID
Supervisor Call	ALL Fleet	Match
Broadcast Call	ALL Fleet	ALL ID

Note: You must select "FleetSync" in the "Optional Signaling" in the **Channel Edit** window or the **GID Edit** window.

■ Individual Call/ Group Call

A user can respond to the party that appears on the display by pressing the **PTT** switch or **[Side 2]/ [■]**.

The transceiver controls the mute function only and does not move to the Call Mode for the following condition.

- The transceiver receives a call from the Fleet inhibited with the Interfleet configuration.
- The receive ID is not registered in Data Encode Block ID.
- The transceiver receives a call having the ID that the TX Inhibit function is enabled in the Selcall List.

The display returns to normal when a key is pressed. The display returns to the last display after the Auto Reset Timer expires if the Auto Reset Timer is configured.

- **When the ID is registered in the ID List (Individual Call):**



TK-2180/ 3180



TK-7180/ 8180

- **When no ID is registered in the ID List (Individual Call):**

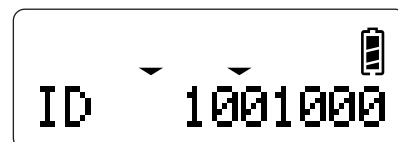

TK-2180/ 3180



TK-7180/ 8180

- When the ID is registered in the ID List (Group Call):

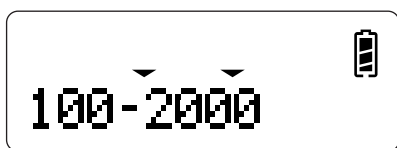

TK-2180/ 3180



TK-7180/ 8180

- When no ID is registered in the ID List:

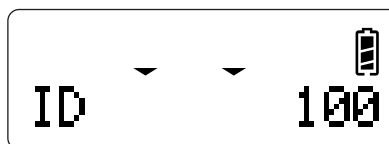

TK-2180/ 3180



TK-7180/ 8180

- When no ID is registered in the ID List (Group Call):

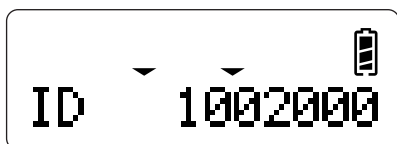

TK-2180/ 3180

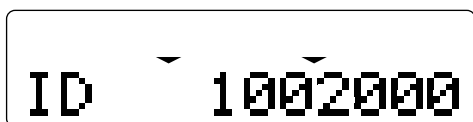

TK-7180/ 8180

■ Supervisor Call/Broadcast Call

A user can respond to the party that appears on the display by pressing the **PTT** switch or **[Side 2]/ [n]** if the ID is registered in the ID List.

The transceiver only controls the mute function and does not enter Call Mode when receiving a call from the party that is not registered in the ID List.

The display returns to normal when pressing a key. The display returns to the last display after the Auto Reset Timer expires if the Auto Reset Timer is configured.

- When the ID is registered in the ID List (Supervisor Call):

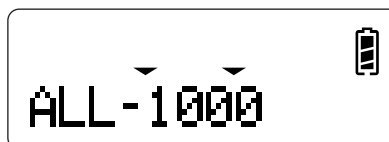

TK-2180/ 3180

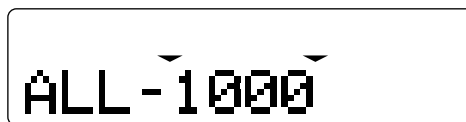

TK-7180/ 8180

■ Fleet Call

You can respond to the party that appears on the display by pressing the **PTT** switch or **[Side 2]/ [n]**.

The transceiver controls the mute function only and does not enter Call Mode when receiving a call from the Fleet that is not registered in the ID List.

The display returns to normal when a key is pressed. The display returns to the last display after the Auto Reset Timer expires if the Auto Reset Timer is configured.

- When the ID is registered in the ID List:



TK-2180/ 3180



TK-7180/ 8180

- When no ID is registered in the ID List (Supervisor Call):

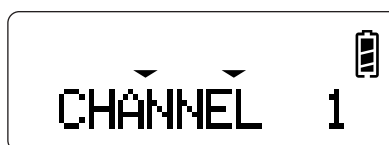

TK-2180/ 3180



TK-7180/ 8180

- When the ID is registered in the ID List (Broadcast Call):



TK-2180/ 3180



TK-7180/ 8180

- When no ID is registered in the ID List (Broadcast Call):

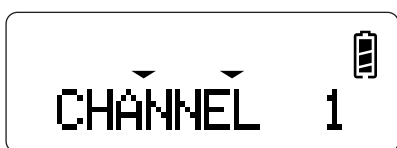

TK-2180/ 3180



TK-7180/ 8180

22.2.3 ID List

The transceiver uses an individual FleetSync ID to perform communications if the FleetSync function is enabled. The FleetSync IDs to be called must be stored in the transceiver using KPG-89D. You can store up to 100 FleetSync IDs.

You can configure the following functions for the ID List using KPG-89D.

Table 22-5 ID List Configuration

ID List	Operation
Fleet	Configure the Fleet of the FleetSync ID. A user can select ALL or the number between 100 and 349. You can call to all IDs when ALL is selected.
ID	Configure the ID of the FleetSync ID. A user can select ALL or the number between 1000 and 4999. You can call to all IDs when ALL is selected.
ID Name	You can configure the caller's ID name. A user can configure a maximum of 10 characters. When the caller's ID Name is registered in the ID List, the ID Name appears on the display.

ID List	Operation
TX Inhibit	Enable/disable the transmission to the receiving party. When the transmission is inhibited, the status does not appear on the ID Selection window and a user cannot select the ID in Message Mode. When receiving a call from the ID, the caller's ID Name appears. In this case, the user cannot make a call to the party even if the PTT switch or the PF Ext. PTT (Voice) port is pressed.

■ Configuration using KPG-89D

- Configuring the ID List (Refer to FPRG 6.12.4 ID List tab.)

22.3 Status Message Function

This function allows a user to send status messages (Status 10 - 99) by selecting the status message numbers. With this function enabled, the dispatcher can send a message to the transceiver.

22.3.1 Sending the Status Message

Following are the methods to send the Status Message.

Table 22-6 How to Send the Status Message

Status Message	Description
Message Mode	The transceiver enters Message Mode when the PF SelCall + Status key or the PF Status key is pressed to send a Status Message. A user can select the Status only by pressing the PF Status key to send the Status Message. In this case, the receiving party is fixed to the target Fleet/ID.
PF Key Direct	The transceiver sends the Status Message assigned to the PF Call 1 - Call 6 keys. A user can assign statuses to No. 1 - 90 of the Status List using the Key Assignment function. In this case, the receiving party is fixed to the target Fleet/ID.
AUX IN	The transceiver sends the Status Message when the status of the AUX IN changes (High > Low or Low > High). In this case, the receiving party is fixed to the target Fleet/ID.
Turning the Transceiver ON/OFF	The transceiver sends the message configured with the KPG-89D when the transceiver is turned ON/OFF. In this case, the receiving party is fixed with the target Fleet/ID.

Status Message	Description
PC Command	The transceiver sends the Status Message via serial command. This message is sent when the transceiver is connected to a PC or the KDS-100 (MDT).

■ **Transceiver Operation**

● **Making a Selective Call with the List Selection:**

1. Press the **PF Status** key or the **PF Selcall + Status** key.

The transceiver enters the List Selection Mode.

The last used ID appears on the display.

The lowest number in the ID List appears on the display at first when the transceiver enters List Selection Mode.

In this case, the receiving party's ID is fixed to the Target ID.

The transceiver enters the Status List Selection Mode when pressing **[S]** after selecting the Selcall ID if the **PF Selcall + Status** key has already been pressed. (Refer to 22.2.1 Making a Selective Call.)

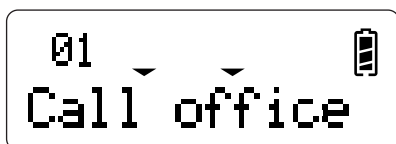

TK-2180/ 3180

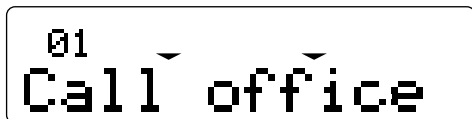

TK-7180/ 8180

2. Select the List number.

- **Common**

Press **[B]/ [C]** to increase/decrease the List number.

- **TK-2180/ 3180** *1

Turn **Selector** clockwise to increase the List number.

Turn **Selector** counterclockwise to decrease the List number.

- **TK-7180/ 8180** *1

Press **[^]/ [v]** to increase/decrease the List number.

*1 When the List Selection Key (Selector) is enabled.

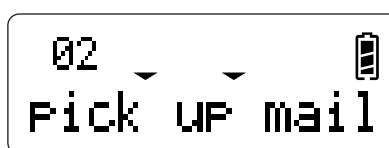

TK-2180/ 3180



TK-7180/ 8180

3. Press the **[PTT]** switch or **[Side 2]/ [■]** to transmit the selected Status List.

Press the **PF Call 1 - 6** keys when transmitting the Status 1 - 6.

The transceiver sends the Status Message.

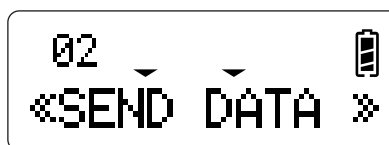

TK-2180/ 3180

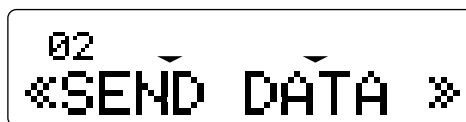

TK-7180/ 8180

- **When the Status Message is properly sent to the receiving party:**

“COMPLETE” appears on the display.



TK-2180/ 3180



TK-7180/ 8180

- **When the Status Message is not properly sent to the receiving party:**

“NO REPLY” appears on the display.



TK-2180/ 3180



TK-7180/ 8180

- **When the Status Message is not properly sent since the receiving party is busy:**

“BUSY” appears on the display.



TK-2180/ 3180



TK-7180/ 8180

- **When you cancel sending the Status Message:**

Press [S1] while “SEND DATA” is appearing on the display.

“CANCEL” appears on the display and the transmission is canceled.

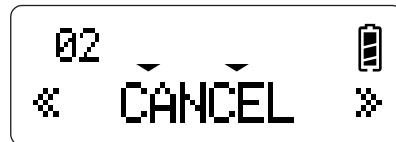

TK-2180/ 3180



TK-7180/ 8180

- **Sending the Status Message Using the Manual Dialing function:**

1. Press the **PF Status** key or the **PF Selcall + Status** key.

The transceiver enters the List Selection Mode.

The transceiver enters the Status List Selection Mode when pressing [S] after selecting the Selcall ID if the **PF Selcall + Status** key is pressed. ([Refer to 22.2.1 Making a Selective Call.](#))

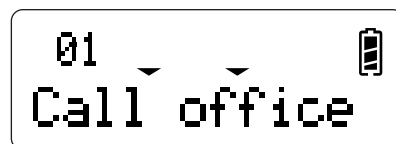

TK-2180/ 3180



TK-7180/ 8180

2. Press and hold **[S]** for more than 1 second.
 The transceiver enters the Status Code Entry Mode.
 The last transmitted the Status Code appears on the display.
 No Status Message appears on the display when the transceiver enters the Status Code Entry Mode for the first time.

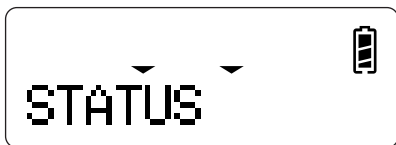

TK-2180/ 3180



TK-7180/ 8180

3. Enter the ID.
 - **Using Selector or PF keys** ^{*1}
 - Select the character using **Selector** or **PF Up/Down** keys.
 - Press **[C]** after entering the ID.
 - ^{*1} When the List Selection Key (Selector) is enabled.
 - **Using the keypad**
 - Enter the Status Code using **[0]** - **[9]**.
 - **Deleting the entered character**
 - Press **[A]** - **[#]**.
The selected character is deleted.
 - Press and hold **[A]** - **[#]**.
All characters are deleted.
4. Press the **PTT** switch or **[Side 2]/ [■]**.
 The transceiver sends the Status Message.

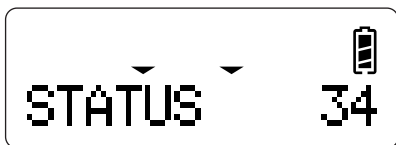

TK-2180/ 3180



TK-7180/ 8180

- **When the Status Message is properly sent to the receiving party:**
 "COMPLETE" appears on the display.



TK-2180/ 3180



TK-7180/ 8180

- **When the Status Message is not properly sent to the receiving party:**
 "NO REPLY" appears on the display.



TK-2180/ 3180



TK-7180/ 8180

- **When the Status Message is not properly sent since the receiving party is busy:**
 "BUSY" appears on the display.



TK-2180/ 3180



TK-7180/ 8180

- **When you cancel sending the Status Message:**

press [S1] while "SEND DATA" is on the display.

"CANCEL" appears on the display and the transmission is canceled.



TK-2180/ 3180



TK-7180/ 8180

- **Transceiver Operation**

1. "RECV DATA" appears on the main display when the transceiver starts receiving data.

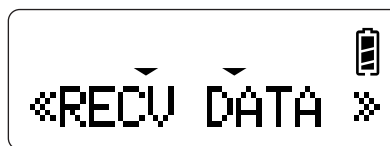

TK-2180/ 3180



TK-7180/ 8180

2. "COMPLETE" appears on the display when receiving the Status Message. (Individual Call only)



TK-2180/ 3180



TK-7180/ 8180

3. The "☑" icon blinks.

- **When the Status Message is configured in the Status List:**

The Status Name configured in the Status List appears.

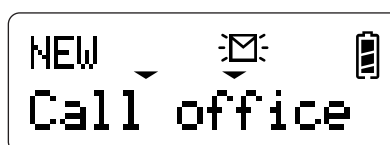

TK-2180/ 3180



TK-7180/ 8180

22.3.2 Receiving the Status Message

This received Status Message is transferred in the following way.

Table 22-7 Status Message Output

Status Message	Description
LCD Display	The received Status Message appears on the LCD. The Status Message appears if the Message Display Type is "Fixed". The Status Message and Selcall ID appears alternatively every second if the Message Display Type is "Alternate".
Alert Tone	Alert Tone sounds when receiving the Status Message.
AUX Out	The status of the AUX Out terminal alternates to high from low when receiving the Status Message
PC Command	The received Status Message is sent via serial command. This message is sent when the transceiver is connected to a PC or the KDS-100 (MDT).

Note:

- ◆ To use serial communications, a user must prepare the FleetSync compatible software or external devices.
- ◆ A user can store a maximum of 15 Messages (Status Message and Short Message).
- ◆ The Status Name appears on the display when receiving the Status Message. "Status xx" appears on the display when receiving the Status Message without the Status Name. (Refer to 22.3.11 Status List.)

- **When no Status Message is configured in the Status List:**

The Status number appears.

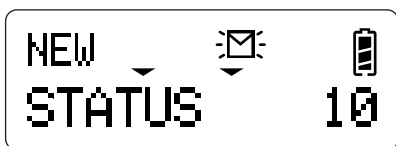

TK-2180/ 3180



TK-7180/ 8180

4. The display returns to the last display.

The “✉” icon stays lit without blinking after reading the Status Message. (Refer to 22.7 Stack.)



TK-2180/ 3180



TK-7180/ 8180

22.3.3 Reserved Status of the Status Message

There is the reserved status for the Status Message. Below is a list of reserved status.

Table 22-8 Reserved Status List

Status	Function	Operation at the receiving party	Enable/disable the Status Input.	
			Manual Dial	PC Control
10 - 79	User Status	Normal Status Reception Operation	Yes	Yes
80	Default Status		Yes/No (*1)	
81 - 87	Undefined			
88	Emergency Reset Command	This status resets the Emergency Status.		
89	Horn Alert Activation Command	This status activates the Horn Alert function. (*2)		
90	Remote Stun Transmission Inhibit Command	The transceiver transmits ACK and inhibits the transmission. In this case, the Current Status becomes “93” (*3)		
91	Remote Stun Transmission/ Reception Inhibit Command	The transceiver transmits ACK and inhibits transmission/ reception. In this case, the Current Status becomes “94”. (*3)		
92	Remote Stun Reset Command	The transceiver transmits ACK and disables the Stun function. In this case, the Current Status becomes “80”.		
93	Remote Stun Transmission Inhibit Response	-		
94	Remote Stun Transmission/ Reception Inhibit Response	-		
95 - 99	Reserved Status for Emergency 98: Man Down Status 99: Emergency Status other than Man Down	The transceiver transmits ACK. Alert/ Horn/ None (*4)		

- *1 You can enable/disable the Status 80 - 99 when using the Manual Dialing function with KPG-89D. (Refer to 22.3.13 Status 80 - 99 (Special).)
- *2 The Horn Alert terminal does not activate when the Off-hook Horn Alert function is disabled and the microphone is in the Off-hook position.
- *3 In this case, the Stun Status does not change even if a user changes the Status in Status Mode.
- *4 You can enable/disable the Status 80 - 99 when using the Manual Dialing function with the KPG-89D. (Refer to 22.3.13 Status 80 - 99 (Special).)

■ Emergency

When the transceiver receives the reserved status message, the Alert or both of the Alert and Horn is activated according to the Emergency Status Response configuration.

■ Remote Stun

This function allows you to disable almost all the transceiver's functions. Only the following operations function when the Stun function is enabled. The transceiver recovers from the Stun status when receiving the Stun Deactivation status message or the Status Deactivation command by DTMF.

Table 22-9 Status Message Output

Status Message	Inhibit TX.	Inhibit TX/RX.
Normal Operation	Inhibit TX.	Inhibit TX/RX.
PC Control	The transceiver does not accept the transmission request. It does not output the received data.	The transceiver does not accept the transmission request. It does not output the received data.

■ Status 90 - 92

These statuses allow you to command or reset the Stun function.

This function operates regardless of the Stun status of the receiving party's transceiver.

■ Status 93 - 94

These statuses are used to respond to the Stun status of the transceiver when receiving the RSTM (Request Status).

22.3.4 Status Message Stack

This function is used to store the received Status Message in the Stack memory. The transceiver can store a maximum of 15 Status Messages.

When the message is stacked, the "☒" icon blinks. In this case, a user can read the stored Status Message by entering Stack Mode. (Refer to 22.7 Stack.)

You can configure the Status Message to be stacked using KPG-89D.

Note: The transceiver can stack a maximum of 15 Status Messages.

■ Configuration using KPG-89D

- Configuring the Status Message Stack (Refer to FPRG 6.12.2 General 2 tab - Status Message Stack.)

22.3.5 Status Message on Data Zone-CH/GID

This function allows the transceiver to automatically change the Data Zone-CH/GID to send the Status Message.

The transceiver automatically changes the channel to Data Zone-CH/GID to transmit the Status Message. The transceiver returns to the previous Zone-CH/GID when the transmission ends. This function allows a user to send data using the selected Zone-Channel/Group ID.

You can enable/disable this function using KPG-89D.

■ Configuration using KPG-89D

- Configuring the Status Message on Data Zone-CH/GID function (Refer to FPRG 6.12.3 Parameter tab - Status Message on Data Zone-CH/GID.)

22.3.6 Status Message Serial Output

This function allows the transceiver to send the caller's Fleet/ID from the transceiver's communication port when the transceiver receives a Status Message.

The dispatcher can remote control the transceiver with a PC. It can also retrieve the transceiver's status information by connecting external devices.

You can enable/disable this function using KPG-89D.

■ Configuration using KPG-89D

- Configuring the Status Message Serial Output (Refer to FPRG 6.12.2 General 2 tab - Status Message Serial Output.)

22.3.7 AUX Input Status Message

This function allows the transceiver to send the Status Message when the status of the AUX IN terminal alternates to low from high.

You can send the Status Message by connecting a sensor to the AUX IN terminal. The transceiver sends the status message to the FleetSync ID configured in the Target Fleet/ID (Status Message).

To enable this function, you must configure the Status Message to the AUX IN terminal.

You can configure the Aux Input Status Message using KPG-89D.

■ Configuration using KPG-89D

- Configuring the AUX Input Status Message (Refer to FPRG 6.12.7 Target tab - AUX Input Status Message 1 - 3.)

22.3.8 AUX Output Status Message

This function allows a user to alternate the Status of the AUX OUT terminal (High > Low or Low > High) when receiving the Status Message. The user can use this function to remotely turn the external device On/Off.

To enable this function, you must configure the Status Message to the AUX Out terminal.

You can configure the AUX Output Status Message using KPG-89D.

■ Configuration using KPG-89D

- Configuring the AUX Output Status Message (Refer to FPRG 6.12.7 Target tab - AUX Output Status Message 1 - 3.)

22.3.9 Power-on Status Message

This function allows the transceiver to send the Status Message when the transceiver is turned ON.

With this function enabled, the dispatcher acknowledges that the transceiver is turned ON. The transceiver sends the status message to the FleetSync ID configured with the Target Fleet/ID (Status Message).

You can configure the Power-on Status Message using KPG-89D.

■ Configuration using KPG-89D

- Configuring the Power-on Status Message (Refer to FPRG 6.12.7 Target tab - Power-on Status Message.)

22.3.10 Power-off Status Message

This function allows a user to send the Status Message when the transceiver is turned OFF.

With this function enabled, the dispatcher acknowledges that the transceiver is turned OFF. The transceiver sends the status message to the FleetSync ID configured with the Target Fleet/ID (Status Message).

You can configure the Power-off Status Message using KPG-89D.

■ Configuration using KPG-89D

- Configuring the Power-off Status Message (Refer to FPRG 6.12.7 Target tab - Power-off Status Message.)

22.3.11 Status List

The Status Message must be configured to the transceiver prior to the transmission. A user can store a maximum of 90 Status Messages in the Status List.

You can configure the Status List using KPG-89D. The Status List has the following functions.

Table 22-10 Selective Call Type

Call Type	Description
Status	You can configure the Status Number. You can configure the number between 10 and 99.
Status Name	You can configure the Status name. It is hard to understand the operation of the Status only with the Status Number. In this case, you can put a name to the Status. You can configure a maximum of 16 characters to each Status name.
TX Inhibit	You can enable/disable the transmission to the receiving party. When the transmission is inhibited, the status does not appear on the Status Selection window. Therefore, a user cannot select the Status in Message Mode if the transmission is inhibited.

■ Configuration using KPG-89D

- Configuring the Status List (Refer to FPRG 6.12.5 Status List tab.)

22.3.12 Target Fleet/ID (Status Message)

The Target Fleet/ID is the receiving party's FleetSync identification to receive the following Status Messages.

- Status Message transmission using the AUX IN terminal
- Power-on Status Message transmission
- Power-off Status Message transmission
- Status Message transmission using the **PF Call 1 - 6** keys
- Status Message transmission after entering Status Message Mode by pressing the **PF Status** key.

You can configure the Target FleetSync ID using KPG-89D. The FleetSync ID of the Base Station is normally used.

■ Configuration using KPG-89D

- Configuring the Target Fleet (Refer to FPRG 6.12.7 Target tab - Target Fleet.)
- Configuring the Target ID (Refer to FPRG 6.12.7 Target tab - Target ID.)

22.3.13 Status 80 - 99 (Special)

Status No. 80 - 99 (reserved status) are used for transceiver specified operations. You can lock these statuses to prevent a user from sending them by mistake.

You can enable/disable the Status No. 80 - 99 (Special) transmission using KPG-89D.

■ Configuration using KPG-89D

- Configuring the Status No.80 - 99 (Special) (Refer to FPRG 6.12.1 General 1 tab - Status No. 80 - 99 (Special).)

22.3.14 Emergency Status Response

Emergency Status Response is the transceiver's operation when receiving the Emergency Status.

"MAN DOWN" appears on the display when the transceiver receives the Status 98. "EMERGENCY" appears on the display when the transceiver receives the Status 99. However, the configured data appears when emergency status is configured in the Status List.

You can configure the following functions for the Emergency Status Response using KPG-89D.

Table 22-11 Emergency Status Response operation

Emergency Status Response	Operation
None	The transceiver works as normal.
Alert	Alert Tone configured in the Emergency Status sounds when receiving the Emergency Status. Press any key other than the Volume Up/Down key to stop Alert Tone.
Horn	The Horn Alert terminal is activated when receiving the Emergency Status. The operation of the Horn varies according to the Horn Alert configuration. The operation of the Alert is also enabled.

■ Configuration using KPG-89D

- Configuring the Emergency Status Response (Refer to FPRG 6.12.1 General 1 tab - Emergency Status Response.)

22.4 Short Message Function

This function allows the transceiver to transmit/receive a maximum of 48 characters.

With this function, you can reliably send information to the transceiver.

22.4.1 Sending the Short Message

You can send the Short Message from a PC. A user is not allowed to send a Short Message from the transceiver.

■ Transceiver Operation

1. Send the serial command to the transceiver from the PC.

The transceiver sends the Short Message.

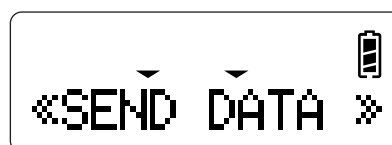

TK-2180/ 3180

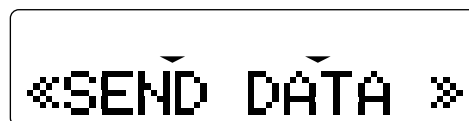

TK-7180/ 8180

- **When the Short Message is properly sent to the receiving party:**

“COMPLETE” appears on the display.



TK-2180/ 3180



TK-7180/ 8180

- **When the Short Message is not properly sent to the receiving party:**

“NO REPLY” appears on the display.



TK-2180/ 3180



TK-7180/ 8180

- **When the Short Message is not sent properly since the receiving party is Busy:**

“BUSY” appears on the display.

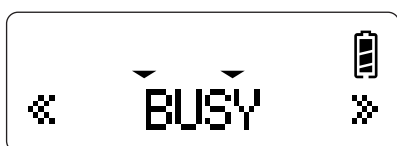

TK-2180/ 3180



TK-7180/ 8180

22.4.2 Receiving the Short Message

This received Short Message data can be transferred in the following way.

Table 22-12 Short Message Output

Short Message	Description
LCD Display	The received Short Message appears on the LCD. The Status Message appears if the Message Display Type is “Fixed”. The Status Message and Selcall ID appears alternatively every second if the Message Display Type is “Alternate”.
Alert Tone	Alert Tone sounds when receiving the Short Message.
PC Command	The received Short Message is sent via serial command. This message is sent when the transceiver is connected to a PC or the KDS-100 (MDT).

■ Transceiver Operation

1. The “RECV DATA” appears on the main display when the transceiver starts receiving data.

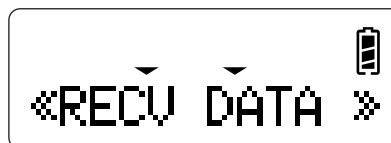

TK-2180/ 3180



TK-7180/ 8180

2. “COMPLETE” appears on the display when receiving the Short Message. (Individual Call only)



TK-2180/ 3180



TK-7180/ 8180

3. The “✉” icon blinks.

The received Short Message appears on the display.

A user can scroll the message from right to left when the Short Message is longer than 12 characters.



TK-2180/ 3180



TK-7180/ 8180

4. The display returns to the last display.

The “✉” icon becomes solid after reading the Short Message. (Refer to 22.7 Stack.)



TK-2180/ 3180



TK-7180/ 8180

Note: To use serial communications, a user must prepare the FleetSync compatible software or external devices.

22.4.3 Short Message Stack

This function is used to store the received Short Message in the Stack memory. The transceiver can store a maximum of 15 Short Messages.

When the message is stacked, the “✉” icon blinks. In this case, a user can read the stored Status Message by entering Stack Mode. (Refer to 22.7 Stack.)

You can configure the Caller ID to be stacked using KPG-89D.

Note: The transceiver can stack a maximum of 15 Messages (Status Message and Short Message).

■ Configuration using KPG-89D

- Configuring the Short Message Stack (Refer to FPRG 6.12.2 General 2 tab - Short Message Stack.)

22.4.4 Short Message on Data Zone-CH/GID

This function allows the transceiver to automatically change the Data Zone-CH/GID to send the Short Message.

The transceiver automatically changes the channel to Data Zone-CH/GID to send the Short Message. The transceiver returns to the previous Zone-CH/GID when transmission ends. This function allows the transceiver to send data using the selected Zone-Channel/Group ID.

You can enable/disable this function using KPG-89D.

■ Configuration using KPG-89D

- Configuring the Short Message on Data Zone-CH/GID function (Refer to FPRG 6.12.3 Parameter tab - Short Message on Data Zone-CH/GID.)

22.4.5 Short Message Serial Output

This function allows the transceiver to send the caller's Fleet/ID from the transceiver's communication port when the transceiver receives a Short Message.

The dispatcher can remote control the transceivers with a PC. It can also retrieve the transceiver's status information by connecting external devices.

You can enable/disable this function using KPG-89D.

■ Configuration using KPG-89D

- Configuring the Short Message Serial Output (Refer to FPRG 6.12.2 General 2 tab - Short Message Serial Output.)

22.5 Long Message Function

This function allows the transceiver to transmit/receive a maximum of 4096 characters.

With this function, a user can reliably send information to the transceiver.

Note: You must select **Optional Features** window > Common-Page 3 > COM port 1 - 3 > "Data".

22.5.1 Sending the Long Message

You can send the Long Message from a PC. A user is not allowed to send the Long Message from the transceiver.

■ Transceiver Operation

1. Send the serial command to the transceiver from the PC.

The transceiver sends the Long Message.

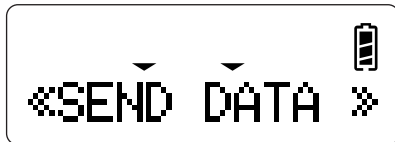

TK-2180/ 3180



TK-7180/ 8180

- **When the Long Message is properly sent to the receiving party:**

"COMPLETE" appears on the display.



TK-2180/ 3180



TK-7180/ 8180

- **When the Long Message is not properly sent to the receiving party:**

"NO REPLY" appears on the display.



TK-2180/ 3180



TK-7180/ 8180

- **When the Long Message is not sent properly since the receiving party is busy:**

"BUSY" appears on the display.



TK-2180/ 3180



TK-7180/ 8180

22.5.2 Receiving the Long Message

The received Long Message data can be transferred to a PC. This message is sent when the transceiver is connected to a PC or the KDS-100 (MDT). Refer to the PC Interface manual for details.

Note: To use serial communications, a user must prepare the FleetSync compatible software or external devices.

■ Transceiver Operation

1. The "RECV DATA" appears on the main display when the transceiver starts receiving data.

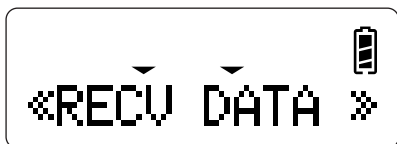

TK-2180/ 3180



TK-7180/ 8180

2. "COMPLETE" appears on the display when receiving the Long Message. (Individual Call only)



TK-2180/ 3180



TK-7180/ 8180

3. The display returns to the last display.
The received Long Message is transferred to the PC with the serial output.

22.5.3 Long Message On Data Zone-CH/GID

This function allows the transceiver to automatically change the Data Zone-CH/GID to send the Long Message.

The transceiver automatically changes the channel to Data Zone-CH/GID to send the Long Message. The transceiver returns to the previous Zone-CH/GID when the transmission ends. This function allows the transceiver to send data using the selected Zone-Channel/Group ID.

You can enable/disable this function using KPG-89D.

■ Configuration using KPG-89D

- Configuring the Long Message on Data Zone-CH/GID function (Refer to FPRG 6.12.3 Parameter tab - Long Message on Data Zone-CH/GID.)

22.6 GPS Function

(TK-7180/ 8180 only)

This function allows the TK-7180/8180 transceiver to send its current location data.

The transceiver transmits the GPS data using the communication port of the transceiver. To use this function, you must connect the GPS receiver unit to the communication port. The receiving base station must utilize a PC, which has mapping software to display the GPS data .

The position of each transceiver appears on the PC's display. This function is convenient for the dispatch control or a traffic control system.

When the Optional VGS-1 unit is installed in the transceiver, the GPS data is sent at the interval configured in the Report Interval that is stored in the VGS-1 Unit.

The following methods are available to send the GPS data.

■ Auto

The transceiver sends the GPS data at the interval configured in the GPS Report Interval.

■ Request (Polling)

The transceiver transmits the GPS data when it receives a transmission request from the base station.

The base station can request 3 types of GPS Data from the transceiver.

This function operates regardless of the "GPS Report Mode" configuration of the receiving party's transceiver.

Table 22-13 GPS Data Request Operation

GPS Data Request	Function
Start	A user can request the receiving party to start sending the GPS data.
Stop	A user can request the receiving party to stop sending the GPS data.
Single	A user can request the receiving party to send the latest GPS data.

The transceiver can send the GPS data 1 - 60 times in a row according to the reception of the GPS data transmission command when the Number of Times is configured using KPG-89D.

The transmission interval varies depending on the Interval time configuration.

■ Manual

Press the **PF Send the GPS Data** key to send the GPS data manually.

■ **PTT**

The transceiver sends the GPS data in conjunction with the PTT operation. You can select the timing to send the GPS data from BOT/ EOT/ and Both.

■ **Status**

The transceiver sends the GPS data in conjunction with the Status Message.

■ **Emergency**

The transceiver sends the GPS data in conjunction with the Emergency transmission operation.

Note:

- ◆ The COM port of the transmitting party connected to the GPS receiver unit must be configured as “GPS”.
- ◆ The COM port of the receiving party connected to the GPS receiver unit must be configured as “GPS” or “Data + GPS Data Output”.

■ **Transceiver Operation**

1. Press the **PF Send the GPS Data** key.

The transceiver sends the GPS data.

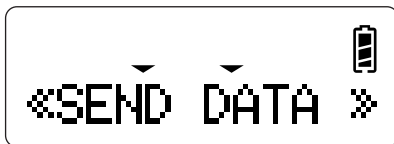

TK-2180/ 3180



TK-7180/ 8180

- **When the GPS data is not sent properly since the receiving party is busy:**

“BUSY” appears on the display.



TK-2180/ 3180



TK-7180/ 8180

22.6.1 Base Fleet/ID

You can configure the FleetSync ID to send the GPS data.

You can configure the Base Fleet/ID using KPG-89D. The FleetSync ID of the base station is normally used.

■ **Configuration using KPG-89D**

- Configuring the Base Fleet (Refer to FPRG 6.12.6 GPS tab - Base Fleet.)
- Configuring the Base ID (Refer to FPRG 6.12.6 GPS tab - Base ID.)

22.6.2 GPS Combination

You can configure the timing to send the GPS data.

A user can add the GPS data when the transceiver is in PTT ID, Status, or Emergency Mode.

You can configure the GPS Combination using KPG-89D. You can configure the following functions.

■ **PTT ID**

The transceiver sends the GPS data with the PTT ID (FleetSync) of the transmitting party. A user can add the GPS data in conjunction with the PTT ID configuration (BOT, EOT, Both).

Following are the ID to be sent and the GPS data.

Table 22-14 ID and GPS data

GPS Report Timing	PTT ID (Channel Edit)			
	Off	BOT	EOT	Both
BOT	-	BOT + GPS	EOT	BOT + GPS EOT
EOT	-	BOT	EOT + GPS	BOT EOT + GPS
Both (BOT)	-	BOT + GPS	EOT + GPS	BOT + GPS EOT
Both (EOT)	-	BOT + GPS	EOT + GPS	BOT EOT + GPS
Both	-	BOT + GPS	EOT + GPS	BOT + GPS EOT + GPS

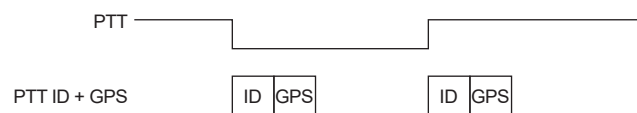

Figure 22-1 Timing for the GPS Combination (PTT ID)

■ Status

The transceiver sends the GPS data with the FleetSync Status Message.

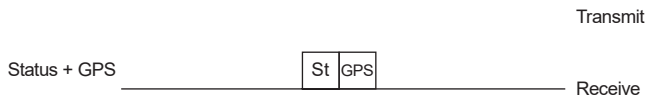

Figure 22-2 Timing to Send the GPS Combination (PTT ID)

■ Emergency

The transceiver sends the GPS data with the Emergency ID (FleetSync).

The GPS data is not added to the DTMF/ANI Board.

Following are the ID to be sent and the GPS data.

Table 22-15 ID and GPS data

Emergency ID	Emergency ID (Emergency Information)			
	None	FleetSync	DTMF	ANI Board*
Check (Enable)	-	FleetSync ID + GPS	DTMF ID	ANI
Uncheck (Disable)	-	FleetSync ID	DTMF ID	ANI



Figure 22-3 Timing for the GPS Combination

■ Configuration using KPG-89D

- Configuring the GPS Combination (PTT ID) (Refer to FPRG 6.12.6 GPS tab - GPS Combination (PTT ID).)
- Configuring the GPS Combination (Status) (Refer to FPRG 6.12.6 GPS tab - GPS Combination (Status).)
- Configuring the GPS Combination (Emergency) (Refer to FPRG 6.12.6 GPS tab - GPS Combination (Emergency).)
- Configuring the PTT ID (Refer to FPRG 6.3.12 PTT ID.)
- Configuring the Emergency ID (Refer to FPRG 6.4.19 Emergency ID.)

22.6.3 GPS Report Mode

This function allows you to select the transmission method: Transmit the GPS data automatically or transmit after receiving the command.

You can configure the GPS Report Mode using KPG-89D. The GPS Report Mode has the following functions.

Table 22-16 GPS Data Request Configuration

GPS Report Mode	Function
Poll	The transceiver sends the GPS data when receiving the GPS data transmission request from the base station. This function is used when the base station controls the timing to send the GPS data. This allows a user to avoid transmit collision.
Auto	The transceiver sends the GPS data at the interval configured in the GPS Report Interval. This function is useful for controlling or monitoring cars as the transceiver frequently transmits the position data to the base station. The transceiver sends the GPS data when receiving the GPS data transmission request from the base station even if the Auto is selected.

■ Configuration using KPG-89D

- Configuring GPS Report Mode (Refer to FPRG 6.12.6 GPS tab - GPS Report Mode.)

22.6.4 Number of Times

This function allows the transceiver to send the GPS data for the configured times when “Poll” is selected in GPS Report Mode.

You can send the GPS data for the configured times at the interval configured in the GPS Report Interval.

You can configure the number of times to send the GPS data using KPG-89D.

■ Configuration using KPG-89D

- Configuring the Number of Times (Refer to FPRG 6.12.6 GPS tab - Number of Times.)

22.6.5 GPS Report Interval Time (Ignition On)

This function allows the transceiver to send the GPS data at the configured intervals when “Auto” is selected in the GPS Report Mode.

The GPS Report Interval (Ignition On) is the interval at which to send the GPS data while the vehicle is moving.

You can configure the interval (to send the GPS data while the vehicle is moving) using KPG-89D.

■ Configuration using KPG-89D

- Configuring the GPS Report Interval (Ignition On) (Refer to FPRG 6.12.6 GPS tab - GPS Report Interval (Ignition On).)

22.6.6 GPS Report Interval Time (Ignition Off)

This function allows the transceiver to send the GPS data at the configured intervals when “Auto” is selected in the GPS Report Mode.

The GPS Report Interval (Ignition Off) is the interval to send the GPS data while the vehicle is parked.

You can configure the interval to send the GPS data while the vehicle is parked using KPG-89D.

■ Configuration using KPG-89D

- Configuring the GPS Report Interval (Ignition Off) (Refer to FPRG 6.12.6 GPS tab - GPS Report Interval (Ignition Off).)

22.6.7 GPS Time Mark

This function allows the transceiver to configure the Offset duration to send the GPS data with UTC (Coordinated Universal Time).

Each transceiver in the fleet transmits the GPS data with different timing. This allows a user to avoid transmit collision.

You can configure the GPS Time Mark using KPG-89D.

Note: The value must be smaller than the GPS Report Interval.

■ Configuration using KPG-89D

- Configuring the GPS Time Mark (Refer to FPRG 6.12.6 GPS tab - GPS Time Mark.)

22.6.8 GPS Message Type

This function allows the transceiver to change the length of the message to send the GPS data.

When “Short” is selected, transmission time for the GPS data can be reduced, compared with ones in the 80 and 150-series.

You can configure the GPS Message Type using KPG-89D.

Table 22-17 GPS Message Type Operation

GPS Message Type	Operation
Full	This message has the same format as the 80/150-Series. The transmission period is approximately 500 ms. The transceiver sends the GPS data, such as \$GPGGA, \$GPRMC, and \$GPGLL.
Short	The transmission period is approximately 320 ms. The transceiver sends the GPS data, such as \$GPGLL. When the base station receives the Short GPS data, a part of data is output as a blank even if the \$GPGGA and \$GPRMC are configured to PC serial-out.

■ Configuration using KPG-89D

- Configuring the GPS Message Type (Refer to FPRG 6.12.6 GPS tab - GPS Message Type.)

22.6.9 GPS Report on Data Zone-CH/GID

This function allows the transceiver to automatically change the Data Zone-CH/GID to send the GPS Report.

The transceiver automatically changes the channel to Data Zone-CH/GID to send the GPS Report. The transceiver returns to the previous Zone-CH/GID when the transceiver finishes transmitting the GPS report. This function allows the transceiver to send data using the selected Zone-Channel/Group ID.

You can enable/disable this function using KPG-89D.

■ Configuration using KPG-89D

- Configuring the PS Report on Data Zone-CH/GID (Refer to FPRG 6.12.6 GPS tab - GPS Report on Data Zone-CH/GID.)

22.6.10 GPS Data Storage

This function allows the transceiver to store the FleetSync GPS data in the VGS-1.

The transceiver can store the GPS data at the GPS Report Interval Time. The transceiver can send the GPS data or it can be read by a PC.

You can configure the GPS data to be stored in the VGS-1 using KPG-89D.

■ Configuration using KPG-89D

- Configuring the GPS Data Storage (Refer to FPRG 6.7.6 VGS-1 tab - GPS Data Storage.)

22.7 Stack

The received Selective Call, Status Message and Short Message are stored in the Stack Memory. A user can confirm or delete the message with the transceiver's operation.

■ Transceiver Operation

● Confirming the message

1. Press and hold the **PF Selcall**, **PF Status**, or **PF Selcall + Status** key for more than one second.

The transceiver enters Stack Mode.

2. Select the message to confirm.

• Common

Press **[B]**/**[C]** to increase/decrease the Stack List number.

• TK-2180/ 3180 *1

Turn **Selector** clockwise to increase the Stack List number.

Turn **Selector** counterclockwise to decrease the Stack List number.

• TK-7180/ 8180 *1

Press **[^]**/**[v]** to increase/decrease the Stack List number.

- *1 When the List Selection Key (Selector) is enabled.



TK-2180/ 3180



TK-7180/ 8180

3. Confirm the message.

The message appears on the display.

● Selective Call

"Inn" appears on the Sub display.

The name of the received ID List appears on the main display.

The ID List code appears when the ID Name is not configured.



TK-2180/ 3180



TK-7180/ 8180

● Status Message

"Snn" appears on the sub display.

The received Status Name appears on the main display.



TK-2180/ 3180



TK-7180/ 8180

● **Short Message**

“Mnn” appears on the sub display.

The received Short Message appears on the main display.



TK-2180/ 3180



TK-7180/ 8180

● **Switching the Message Display**

1. Press and hold [S] for 1 second while the message is on the display.

Switch the received message display in the order of the ID > Channel Name > Time Stamp.

● ID



TK-2180/ 3180



TK-7180/ 8180

● Channel Name



TK-2180/ 3180



TK-7180/ 8180

● Time Stamp

24-hour format

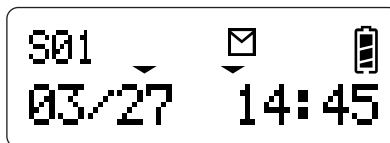

TK-2180/ 3180

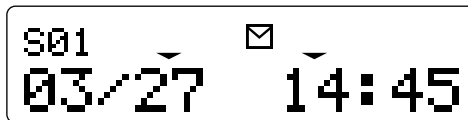

TK-7180/ 8180

12-hour format

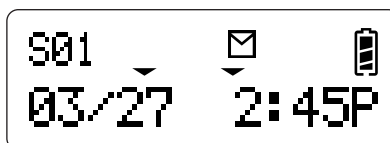

TK-2180/ 3180

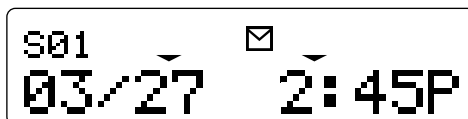

TK-7180/ 8180

● **Deleting the Message**

1. Select the Stack List to delete.

● **Common**

Press [B]/ [C] to increase/decrease the Stack List number.

● **TK-2180/ 3180** *1

Turn **Selector** clockwise to increase the Stack List number.

Turn **Selector** counterclockwise to decrease the Stack List number.

● **TK-7180/ 8180** *1

Press [^]/ [v] to increase/decrease the Stack List number.

*1 When the List Selection Key (Selector) is enabled.

Press [A] or [#] to return to the **Stack List** window without deleting messages.



TK-2180/ 3180



TK-7180/ 8180



TK-2180/ 3180



TK-7180/ 8180

2. Press [A] or [#].
"DELETE" appears on the display.



TK-2180/ 3180



TK-7180/ 8180

3. Press [S] or [*].
The message is deleted.
Press [A] or [#] to return to the **Stack List** window without deleting the message.

● **Deleting All Messages**

1. Press and hold [A] or [#] for more than one second.
"ALL" appears on the sub display and "DELETE?" appears on the main display.



TK-2180/ 3180



TK-7180/ 8180

2. Press [S] or [*].
All messages are deleted and "EMPTY" appears on the display.

22.7.1 Stores the Latest Received Messages

This function allows you to select how to stack the Caller ID, Status Message and Short Message.

You can configure this function using KPG-89D.

Table 22-18 Stores the Latest Received Messages Configuration

Stores the Latest Received Message	Function
Check (Enable)	The transceiver stacks a maximum of 15 received messages. When the transceiver receives the 16th message, it deletes the first message and stacks 2nd - 16th messages (always last 15 messages).
Uncheck (Disable)	The transceiver stacks a maximum of 15 received Messages. When the transceiver receives the 16th message, it does not stack the 16th messages.

■ **Configuration using KPG-89D**

- Configuring the Stores the latest received message function (Refer to FPRG 6.12.2 General 2 tab - Stores the latest received message.)

22.7.2 Caller ID Stack

This function allows the transceiver to store the IDs of the callers to the Stack Memory.

The transceiver can store a maximum of three IDs. The transceiver can stack a maximum of 15 messages (Status Message and Short Message).

The user can reply to the displayed Caller ID by pressing the **PTT** switch or the PF Ext. PTT (Voice) port in Caller ID Stack Mode.

When the transceiver receives a call with FleetSync ID, the "☑" icon blinks to notify the user that the ID is stored. The user can enter Stack Mode to check the stored FleetSync IDs.

The method to stack the IDs varies depending on the Stores the latest received messages configuration. (Refer to [22.7.1 Stores the Latest Received Messages.](#))

You can enable/disable the Caller ID Stack function using KPG-89D.

■ Configuration using KPG-89D

- Configuring the Caller ID Stack (Refer to FPRG 6.12.2 General 2 tab - Caller ID Stack.)

22.7.3 ID/Message Stack with Time Stamp

This function allows the transceiver to stack Caller ID, Status Message, and Short Message with the received time stamp.

You can configure the received time whether or not to be stacked with the ID or message using KPG-89D.

■ Configuration using KPG-89D

- Configuring the ID/Message Stack with Time Stamp function (Refer to FPRG 6.12.2 General 2 tab - ID/ Message Stack with Time Stamp.)

22.7.4 Message Memory

This function allows the transceiver to stack Caller ID, Status Message, and Short Message even if the transceiver is turned OFF.

You can configure the message to be stored using KPG-89D.

■ Configuration using KPG-89D

- Configuring the Message Memory (Refer to FPRG 6.12.2 General 2 tab - Message Memory.)

22.8 Timer Function

This function allows the transceiver's time to be adjusted. A user can use this function to add the Time Stamp to the received information.

Followings are the time adjustment functions.

Table 22-19 Timer Function List

Timer Function	Function
Remote update function of the internal timer of the transceiver over the air	This function allows a user to adjust the time contained in the data according to the clock Update request transmitted over the air from the Base Station. This function corrects the time of the internal clock if the transceiver. The user can adjust the internal clock of the target transceiver in the same system by using the base station time as the standard time .

Note: This function may not be available for older versions of transceivers. Refer to the PC Interface Protocol manual for details before you perform this function.

22.9 Configuring the FleetSync

You can configure the following functions relating to FleetSync using KPG-89D.

- Own Fleet/ID
- Unit ID Encode Block
- Interfleet Call
- FleetSync Baud Rate
- Auto Reset Timer
- FleetSync II
- Manual Dialing
- Group ID
- GTC Count
- Number of Retries
- Transmit Busy Wait Time
- Maximum ACK Wait Time
- ACK Delay Time
- Transmit Delay Time (Receive Capture)
- Data Transmit Modulation Delay Time
- Random Access (Contention)
- Unit ID Serial Output
- Selective Call Alert LED
- Message Display Type
- Alert Tone (Individual Call)
- Alert Tone (Other Selective Calls)

- Alert Tone (Paging Call)
- Alert Tone (Status/Short Message Call)
- Alert Tone (Emergency Response)
- PC Interface Protocol

Note: A user cannot make a Interfleet Call regardless of the configuration of this function when making a Interfleet Call with the PC Command.

■ Configuration using KPG-89D

- Configuring the Interfleet Call (Refer to FPRG 6.12.1 General 1 tab - Interfleet Call.)

22.9.1 Own Fleet/ID

The FleetSync ID consists of 3-digit Fleet number (100 - 349) and 4-digit (1000 - 4999) ID number.

This ID is used for the PTT ID, making a call and FleetSync data communications.

You can configure the FleetSync ID using KPG-89D.

■ Configuration using KPG-89D

- Configuring the Fleet (Refer to FPRG .12.1 General 1 tab - Fleet.)
- Configuring the ID (Refer to FPRG 6.12.1 General 1 tab - ID.)

22.9.2 Unit ID Encode Block

The Unit ID Encode Block is the FleetSync ID range to make a call.

You can limit the FleetSync range using KPG-89D. You can use the FleetSync ID registered in the ID List even if it is outside the Unit ID Encode Block range.

Transceivers without the Unit ID Encode Block function can call all transceivers.

Following are available FleetSync IDs.

Table 22-20 Available FleetSync IDs

Unit ID Encode Block	Inter-Fleet Call Configuration	
	On (Check)	Off (Uncheck)
On	Unit ID Encode Block in all Fleet	Unit ID Encode Block in Own Fleet
Off	All Fleet IDs	All IDs in Own Fleet

■ Configuration using KPG-89D

- Configuring the Unit ID Encode Block (Refer to FPRG 6.12.1 General 1 tab - Unit ID Encode Block.)

22.9.3 Interfleet Call

This function allows a user to make a call using the FleetSync ID having a different Fleet number.

The user can inhibit making a call to the FleetSync ID having the different Fleet number by disabling the Interfleet Call function using KPG-89D. It also prevents Interfleet IDs from being used inadvertently.

You can enable/disable the Interfleet Call function using KPG-89D.

22.9.4 FleetSync Baud Rate

The FleetSync Baud Rate is the data baud rate for the internal MSK modem.

The FleetSync Baud Rate configuration of both the transmitting and receiving parties must be the same.

You can configure the FleetSync Baud Rate using KPG-89D. You can configure the following baud rates.

Table 22-21 Available Baud Rate

FleetSync Baud Rate	Operation
1200 bps	This configuration is recommended for regular communications.
2400 bps	With this configuration, a user can transmit data in shorter time compared with 1200 bps. However, errors are more likely to occur as communications are performed at high speeds. The available data communication area becomes smaller than at 1200 bps.

■ Configuration using KPG-89D

- Configuring the FleetSync Baud Rate (Refer to FPRG 6.12.1 General 1 tab - FleetSync Baud Rate.)

22.9.5 Auto Reset Timer

This function allows a user to reset the LED, Alert Tone, Monitor, and the LCD to the previous display after a certain period elapses.

You can configure the following functions for the Auto Reset Timer.

Table 22-22 Auto Reset Timer Operation

Auto Reset Timer	Operation
Off	Auto Reset Timer does not work.
1 - 300 s	The LED, Alert Tone, Monitor, and the LCD return to the last display when the configured period expires.
LED	The orange Selective Call Alert LED stops blinking when the Auto Reset Timer expires.
Alert	The intermittently emitted Alert Tone pauses when the Auto Reset Timer expires.
Monitor	The match status of the Selective Call resets when the Auto Reset Timer expires.
LCD	The display returns to the channel display when the Auto Reset Timer expires.

■ Configuration using KPG-89D

- Configuring Auto Reset Timer (Refer to FPRG 6.12.2 General 2 tab - Auto Reset Timer.)

22.9.6 FleetSync II

The FleetSync II is a new FleetSync format utilizing FEC (Forward Error Correction) technology. This format corrects errors in order to perform more reliable data communications than in conventional data communications.

In the FleetSync II, extended bits are added to correct errors. Therefore, the data length is 4 times as long as the original format.

You can configure the data communication to use the FleetSync II format using KPG-89D.

Note: The FleetSync II format is not compatible with the original FleetSync format.

■ Configuration using KPG-89D

- Configuring the FleetSync II (Refer to FPRG 6.12.1 General 1 tab - FleetSync II.)

22.9.7 Manual Dialing

This function allows a user to directly enter the Fleet and the ID number.

When this function is enabled, you can directly enter the Fleet/ID using the Keypad, **Selector**, or the **[Up]/[Down]** keys.

You can enable/disable this function using KPG-89D.

■ Configuration using KPG-89D

- Configuring the Manual Dialing (Refer to FPRG 6.12.1 General 1 tab - Manual Dialing.)

22.9.8 Group ID

A user can make a Group Call using FleetSync. This function allows the user to assign the same Divisional ID to the transceivers in the same Group. The user can make a call in the smaller unit than Fleet Call and Supervisor Call. The user can normally make this call in the same Fleet.

Table 22-23 Group ID Response

Call Type	Response	
	The ID is included in the ID List.	The ID is not included in the ID List.
Group Call	A user can respond with a Group Call.	The user can respond with a Group Call. However, the user may not be able to respond according to the Interfleet configuration and the Unit Encode Block configuration.

Check the "Group Call" checkbox when configuring the Group Call and configure the Divisional ID. You can configure a maximum of 10 Divisions.

You can configure the Group Call using KPG-89D

■ Configuration using KPG-89D

- Configuring the Group ID (Refer to FPRG 6.12.1 General 1 tab - Group ID.)
- Configuring the Group ID (1 - 10) (Refer to FPRG 6.12.1 General 1 tab - Group ID (1 - 10).)

22.9.9 GTC Count

This function allows you to configure the number of times to transmit the GTC.

GTC (Go To Channel) is a message that allows the transmitting party to take the receiving party to the data channel.

The caller's transceiver transmits the GTC and moves to the data channel when the Status/ Short/Long Message on the Data Channel is configured. The receiving party's transceiver automatically moves to the data channel and waits for the data.

You can configure the GTC to be sent and the number of times to send it using KPG-89D. A user can normally use the default configuration.

Note:

- ◆ The receiving party's transceiver waits for receiving the Status/ Short/Long Message after it moves to the data channel. The transceiver returns to the voice channel when no data is received during the Maximum Ack Wait Time.
- ◆ The caller's transceiver sends the Status/Short/Long Message and waits to receive the ACK after it moves to the data channel. The transceiver returns to the voice channel when it does not receive the ACK for the Maximum Ack Wait Time.

■ Configuration using KPG-89D

- Configuring the GTC Count (Refer to FPRG 6.12.3 Parameter tab - GTC Count.)

22.9.10 Number of Retries

If the transceiver does not receive the ACK for the Maximum ACK Wait Time, it resends data. You can configure the Number of Retries. Decrease the number when communication conditions are good and increase the number when the communication conditions are not.

You can configure the Number of Retries using the KPG-89D.

■ Configuration using KPG-89D

- Configuring the Number of Retries (Refer to FPRG 6.12.3 Parameter tab - Number of Retries.)

22.9.11 Transmit Busy Wait Time

The TX Busy Wait Time is the period the transceiver withholds the FleetSync data transmission when the line is Busy. The transmission is canceled when the line is busy even if the Transmit Busy Wait Time expires.

You can configure the Transmit Busy Wait Time using KPG-89D.

■ Configuration using KPG-89D

- Configuring the Transmit Busy Wait Time (Refer to FPRG 6.12.3 Parameter tab - Transmit Busy Wait Time.)

22.9.12 Maximum ACK Wait Time

The Maximum ACK Wait Time is the duration for the transceiver to wait for receipt of the ACK from the receiving party after transmitting data. If the transceiver does not receive the ACK after the Maximum ACK Wait Time, it resends data.

You can configure the Maximum ACK Wait Time using KPG-89D. We recommend using the default configuration.

Note:

- ◆ This period is applied to the wait time for receiving data after moving to the data channel using the GTC function.
- ◆ The Long Data Message is sent several times. The receiving party's transceiver waits the next data during the Maximum ACK Wait Time. The transceiver exits the Long Data Message Reception Mode when it does not receive any data during the period.

■ Configuration using KPG-89D

- Configuring the Maximum ACK Wait Time (Refer to FPRG 6.12.3 Parameter tab - Maximum ACK Wait Time.)

22.9.13 ACK Delay Time

The ACK Delay Time is the delay time between time the transceiver receives FleetSync and the time when it transmits the ACK.

This period must be shorter than Maximum ACK Wait Time configured in the caller's transceiver. In addition, this period must be shorter than the Hang Time of the repeater when using the ARQ function in a Trunking system. ([Refer to 17.7 ARQ Mode.](#))

You can configure the ACK Delay Time using KPG-89D. We recommend using the default configuration.

■ Configuration using KPG-89D

- Configuring the ACK Delay Time (Refer to FPRG 6.12.3 Parameter tab - ACK Delay Time.)

22.9.14 Transmit Delay Time (Receive Capture)

The Transmit Delay Time is the transmit period of the unmodulated carrier prior to the data transmission.

The transmitting transceiver performs the unmodulated transmission and the receiving transceiver stops scanning to receive the data. With this function, a user

can reliably send the data even if the receiving party's transceiver is performing Scan or using the Battery Saver function.

You can configure the Transmit Delay Time using KPG-89D. We recommend using the default configuration.

■ Configuration using KPG-89D

- Configuring the Transmit Delay Time (Refer to FPRG 6.12.3 Parameter tab - Transmit Delay Time.)

22.9.15 Data Transmit Modulation Delay Time

The Data Transmit Modulation Delay Time is the transmit period of the unmodulated carrier prior to sending the data in MSK modulation.

This delay time is used to stabilize the transceiver before starting the MSK modulation. However, it may be difficult to perform data communications when the transmit/receive frequencies are completely different or the transceiver is used in extremely cold areas. In such cases, configure this delay time long in order to improve data communications.

You can configure the Data Transmit Modulation Delay Time using KPG-89D. We recommend using the default configuration.

■ Configuration using KPG-89D

- Configuring the Data Transmit Modulation Delay Time (Refer to FPRG 6.12.3 Parameter tab - Data Transmit Modulation Delay Time.)

22.9.16 Random Access (Contention)

This function allows the transceiver to randomize the transmission start time for data when the channel becomes free.

If multiple transceiver begin transmitting as soon as the channel becomes free, transmission collision occur.

You can configure the Random Access function using KPG-89D

Note: The Random Access period varies depending on the configuration in the **FleetSync** > the **General 1** tab > FleetSync Baud Rate.

■ Configuration using KPG-89D

- Configuring the Random Access function (Refer to FPRG 6.12.3 Parameter tab - Random Access.)

22.9.17 Unit ID Serial Output

This function allows the transceiver to send the caller's Fleet/ID from the transceiver's communication port when the transceiver receives the PTT ID.

With this function enabled, the dispatcher can monitor the transceivers.

You can enable/disable this function using KPG-89D.

Note: You must select "Data" in COM port when using the Unit ID Serial Output function.

■ Configuration using KPG-89D

- Configuring the Unit ID Serial Output (Refer to FPRG 6.12.2 General 2 tab - Unit ID Serial Output.)

22.9.18 Selective Call Alert LED

This function makes the SelCall Alert LED blink when receiving a Selective Call. ([Refer to 22.2 Selective Call Function.](#))

You can configure the SelCall Alert LED to blink using KPG-89D.

■ Configuration using KPG-89D

- Configuring the Selective Call Alert LED (Refer to FPRG 6.12.1 General 1 tab - Selective Call Alert LED.)

22.9.19 Message Display Type

This function allows you to configure the display when receiving the Status/Short Message.

You can configure this function using KPG-89D. The following main display types are available.

Table 22-24 Auto Reset Timer Operation

Message Display Type	Operation
Fixed	"STM/SDM" appears on the display when receiving a call. A user can scroll the message when the message is longer than 13 characters.
Alternate	"STM/SDM" and SelCall ID is displayed alternatively when receiving a call.

Note: The display returns to the last display if a key is pressed while the received message is displayed.

■ Configuration using KPG-89D

- Configuring the Message Display Type (Refer to FPRG 6.12.1 General 1 tab - Message Display Type.)

22.9.20 Alert Tone (Individual Call)

Alert Tone (Individual Call) sounds when receiving an Individual Call. You can select one of 8 tones configured in Special Alert Tone.

Note: When "Infinite" is selected in the **Special Alert Tone** window > **Cycle**, the transceiver stops emitting this tone when Auto Reset Timer expires.

■ Configuration using KPG-89D

- Configuring Alert Tone (Individual) (Refer to FPRG 6.12.2 General 2 tab - Alert Tone (Individual).)

22.9.21 Alert Tone (Other Selective Calls)

Alert Tone (other Selective Calls) sound when receiving a Selective Call. A user can select one of 8 tones configured in Special Alert Tone.

Note:

- ◆ Alert Tone (other Selective Calls) is used for Group Call, Fleet Call, Supervisor Call, and Broadcast Call.
- ◆ When "Infinite" is selected in the **Special Alert Tone** window > **Cycle**, the transceiver stops emitting this tone when Auto Reset Timer expires.

■ Configuration using KPG-89D

- Configuring Alert Tone (Other Selective Calls) (Refer to FPRG 6.12.2 General 2 tab - Alert Tone (Other Selective Calls).)

22.9.22 Alert Tone (Paging Call)

Alert Tone (Paging Call) sounds when receiving a paging call. A user can select one of 8 tones configured in Special Alert Tone.

Note: When "Infinite" is selected in the **Special Alert Tone** window > **Cycle**, the transceiver stops emitting this tone when Auto Reset Timer expires.

■ Configuration using KPG-89D

- Configuring Alert Tone (Paging Call) (Refer to FPRG 6.12.2 General 2 tab - Alert Tone (Paging Call).)

22.9.23 Alert Tone (Status/Short Message Call)

Alert Tone (Status/Short Message Call) sounds when the Status/Short Message data is stacked. A user can select one of 8 tones configured in Special Alert Tone.

Note: When "Infinite" is selected in the **Special Alert Tone** window > **Cycle**, the transceiver stops emitting this tone when Auto Reset Timer expires.

■ Configuration using KPG-89D

- Configuring Alert Tone (Status/Short Message Call) (Refer to FPRG 6.12.2 General 2 tab - Alert Tone (Status/Short Message Call).)

22.9.24 Alert Tone (Emergency Response)

Alert Tone (Emergency Response) sounds when the Emergency Response function is configured to "Alert". A user can select one of 8 tones configured in Special Alert Tone.

Note: When "Infinite" is selected in the **Special Alert Tone** window > **Cycle**, the transceiver stops emitting this tone when Auto Reset Timer expires.

■ **Configuration using KPG-89D**

- Configuring Alert Tone (Emergency Response)
(Refer to FPRG 6.12.2 General 2 tab - Alert Tone
(Emergency Response).)

22.9.25 PC Interface Protocol

There are 2 types of PC Interface Protocol (Version 1, Version 2).

The Version 1 is the same protocol that is used by the 80 and 150-series.

The Version 2 is a new protocol. In this version, a Sequence is added to the command and the ACK function, which is sent after receiving the command. Therefore, it is easier to control the transceiver from a PC.

You can configure PC Interface Protocol using KPG-89D.

■ **Configuration using KPG-89D**

- Configuring PC Interface Protocol (Refer to FPRG 6.12.1 General 1 tab - PC Interface Protocol.)

Scan allows the transceiver to monitor other channels.

When the transceiver detects activity, it stops scanning and unmutes a Conventional Group. This allows a user to talk and listen to the person transmitting without changing the channels.

The transceiver checks the Group ID call in a Trunking system, then receives a Decode Group ID.

There are two types of scan: Manual Scan and Automatic Scan.

■ Manual Scan

Press the **PF Scan** key to start scan.

- Single Scan:

The transceiver scans the CH/GID in the Zone appearing on the display. The transceiver scans the Priority Channel even if no Priority Channel is configured in the displayed Zone.

- Multi Scan:

The transceiver scans the Zone CH/GID. The transceiver scans the Priority Channel even if no Priority Channel is configured in the selected Zone.

- List Scan:

The transceiver scans the Zone CH/GID configured in the Scan List Table. The transceiver scans the Priority Channel even if no Priority Channel is configured in the selected Zone.

■ Automatic Scan

- Group Scan:

The transceiver automatically scans the Group ID in the selected Zone when selecting the Zone in Trunking systems.

23.1 Scan Operation

23.1.1 Conditions to Activate Scan

Press the **PF Scan** key to activate the configured scan (Single Zone Scan/ Multi Zone Scan/ List Scan).

One of the following conditions must be met to activate scan by pressing the **PF Scan** key. An Error Tone sounds when the conditions do not meet the requirements to activate scan.

- At least, 2 Add CH/GIDs must be configured in the Scan Start Zone.
- At least, 1 Add CH/GID must be configured in the Scan Start Zone and the Priority Channel is configured in the same Zone or another Zone.
- Priority Channel 1 and Priority Channel 2 must be configured in the Scan Start Zone or other Zones when no Add CH/GID is configured in the Scan Start Zone.

23.1.2 Conditions to Resume Scan

One of the following conditions must be met to resume scan. An Error Tone sounds when the transceiver does not meet the requirements to resume scan and the “” icon appears.

- At least, 2 Add CH/GIDs are configured in the Scan Start Zone.
- At least, 1 Add CH/GID is configured in the Scan Start Zone and the Priority Channel is configured in the same Zone or another Zone.
- Priority Channel 1 and Priority Channel 2 must be configured in the Scan Start Zone or other Zones when no Add CH/GID is configured in the Scan Start Zone.

Press the **PF ScanZ Del/Add** key while scan pauses to temporary delete or add the channel. This status remains until the **PF Scan** key is pressed again.

The Priority Channel is always operated as an Add Channel.

23.1.3 Operations when Scan cannot be Resumed

During scan, the selected CH/GID and the “” icon appear when the channel is changed to the Zone that does not meet the requirements to resume scan. In this case, scan does not resume.

The transceiver transmits using the Revert CH/GID when pressing the **PTT** switch while the “” icon is blinking. The transceiver returns to the selected CH/GID when it completes transmitting and the Dwell Time expires. In this case, scan does not resume.

23.1.4 Manually Changing the Zone-CH/GID during Scan

The transceiver performs the following operation when changing the Zone-CH/GID while the following window appears.

Table 23-1 Operations after Changing the Zone-CH/GID

Display	Operation
Scan	The transceiver scans using the Selected CH/GID. It resumes scan after the Key Dwell Time expires.
Revert CH/GID	The transceiver pauses scanning on the selected CH/GID when the Revert CH/GID is different from the selected CH/GID.

The transceiver performs the following operation when the **PF Home CH/GID** key is pressed during scan.

Table 23-2 Operations after the PF Home CH/GID Key is Pressed

Scan Type	Operation
Scan Type	The transceiver pauses on the Home CH/GID. The Lookback function of the Priority Scan will not be activated. The transceiver returns to the selected channel and resumes scan when the PF Home CH/GID key is pressed again. The Scan Stop Tone sounds every 5 seconds when scan pauses.
Single Scan	The transceiver moves to the Home CH/GID in the Selected Zone. The Selected Channel is not changed.
Multi Scan	The transceiver moves to the Home CH/GID in the Revert Zone. The Selected Channel is not changed.

The transceiver performs the following operation when the **PF Direct CH/GID 1 - 5** key is pressed during scan. The operation of the transceiver varies depending on the configuration of the Return function. Operations after the PF Direct CH/GID Key is Pressed

Return	Operation
Disabled	<ul style="list-style-type: none"> The transceiver pauses scan using the Direct CH/GID 1 - 5 key. The transceiver resumes scan from the Direct CH/GID after the Key Dwell Time expires when no signal is detected. The same operation is made when using Priority Scan. If the Direct CH/GID 1 - 5 is the channel and the Priority is configured to "Selected", the Direct CH/GID 1 - 5 becomes the Priority Channel. If the Revert Channel is configured to "Selected", the Revert Channel becomes Direct CH/GID 1 - 5.

Return	Operation
Enabled	<p>The transceiver pauses scanning using the Direct CH/GID 1 - 5 key. The Lookback function of the Priority Scan will not be activated.</p> <p>The transceiver returns to the selected channel and resumes scan when the PF Direct CH/GID key is pressed again. The Scan Stop Tone sounds every 5 seconds while scan pauses.</p>

23.1.5 Operations when Manually Changing the Zone-CH/GID while Scan Pauses to Receive

The transceiver performs the following operation when manually changing the Zone-CH/GID while scan pauses to receive.

- The transceiver pauses on the Selected CH/GID when the CH/GID that scan pauses is different from the Selected CH/GID.

23.1.6 Operations during Scan in Conventional Group

The transceiver performs the following operation according to the configuration in the **Zone Edit** window (Conventional Group) > Audio Control.

■ QT/DQT Function

The transceiver pauses scan when the received QT/DQT matches on each channel. The Dropout Delay Time activates when the received QT/DQT does not match the configured QT/DQT. The transceiver resumes scan after the Dropout Delay Time expires.

The transceiver transmits using the Revert Channel when the **PTT** switch is pressed. The transceiver activates the Dwell Time when the transmission ends, then resumes scan after the Dwell Time expires.

■ QT/DQT - Optional Signaling AND Function

The transceiver pauses scan when the received QT/DQT matches. The transceiver mutes and waits for receipt of the Optional Signaling.

The transceiver resumes scan after the Dropout Delay Time expires when the QT/DQT does not match the configured QT/DQT while waiting for receiving the Optional Signaling.

The transceiver unmutes by performing Alert/Transpond when the QT/DQT matches the configured QT/DQT while waiting for receipt of the Optional Signaling. The transceiver stands by on the channel when the Optional Signaling matches.

■ QT/DQT - Optional Signaling OR Function

The transceiver pauses scan when the received QT/DQT matches. The transceiver unmutes and waits for receipt of the Optional Signaling.

The transceiver mutes and resumes scan after the Dropout Delay Time expires when the QT/DQT does not match configured QT/DQT while waiting for receipt of the Optional Signaling.

If scan pauses after the received Optional Signaling matches the configured Optional Signaling, the transceiver continues pausing scan even if the match status of the Option Signaling resets.

23.1.7 Operations while Making Scan in Trunking System

The transceiver performs the following operation according to the configuration in the **Zone Edit** window (Trunking system) > Audio Control.

■ LTR ID Function

The transceiver pauses scan when the Decode LTR ID matches the Group ID that is configured in the Scan List. The Dropout Delay Time activates when the match status of Decode LTR ID resets. The transceiver resumes scan after the Dropout Delay Time expires.

The transceiver transmits using the Revert Channel when the **PTT** switch is pressed. The transceiver activates the Dwell Time when the transmission ends, then resumes scan after the Dwell Time expires.

■ LTR ID - Optional Signaling AND Function

The transceiver stops scan when the Decode LTR ID matches the Group ID that is configured in the Scan List. The transceiver mutes and waits for receiving the Optional Signaling.

The transceiver resumes scan after the Dropout Delay Time expires when the match status of the Decode LTR ID resets while waiting for receiving the Optional Signaling.

The transceiver unmutes by performing Alert/Transpond when the QT/DQT matches the configured QT/DQT while waiting for receipt of the Optional Signaling. The transceiver stands by on the Group ID when the Optional Signaling matches.

■ LTR ID - Optional Signaling OR Function

The transceiver stops scan when the Decode LTR ID matches the Group ID that is configured in the Scan List. The transceiver unmutes and waits for receipt of the Optional Signaling.

The transceiver mutes and resumes scan after the Dropout Delay Time expires when the match status of the Decode LTR ID resets while waiting for receipt of the Optional Signaling.

The transceiver performs the Alert function or the Transpond function when the Optional Signaling matches while waiting for receipt of Optional Signaling.

Note: The transceiver moves to the LTR ID having the higher priority when receiving the LTR ID having higher priority than the current LTR ID in Trunking system.

23.2 Single Scan

This function allows the transceiver to scan the Scan Start Zone only.

The following CH/GIDs are added to the Scan List.

- Selected in Scan Add in the **Channel Edit** window or the **GID Edit** window.
- The CH/GID that is added using the **PF Scan Del/Add** key

The transceiver scans the Priority Channel even if no Priority Channel is configured in the selected Zone.

You must select "Single" in the Scan Type to activate the Single Scan.

■ Transceiver Operation

● Activating Scan

1. Press the **PF Scan** key.

The transceiver starts scanning.

- Normal Scan

The "Scan" appears on the main display and the "↻" icon appears.

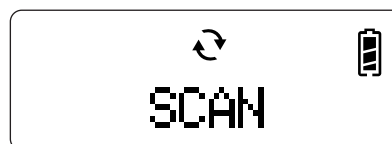

TK-2180/ 3180



TK-7180/ 8180

- When scan pauses during scan

The transceiver pauses scanning. The “↻” icon blinks.



TK-2180/ 3180



TK-7180/ 8180

- **Deactivating Scan**

1. Press the **PF Scan** key during scan.

The “↻” icon disappears and the scan ends.

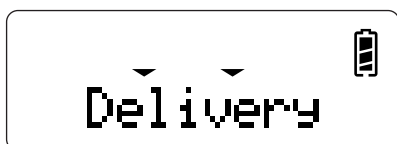

TK-2180/ 3180

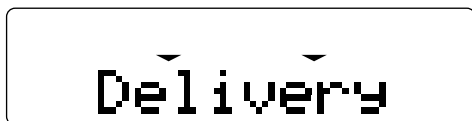

TK-7180/ 8180

- **Configuration using KPG-89D**

- Configuring the Scan Type (Refer to FPRG 6.9.10 Scan Type.)
- Assigning functions to the **PF** keys (Refer to FPRG 6.8 Key Assignment.)

23.3 Multi Scan

The Multi Scan scans all Zone CH/GIDs.

The following Zone-CH/GIDs are added to the Scan List.

- A Zone that is added using the Zone Add function.
- A CH/GID that is added using the Scan Add function.
- A CH/GID that is added using the **PF Scan Del/Add** key

The transceiver scans the Priority Channel even if no Priority Channel is configured in the selected Zone.

You must select “Multi” in the Scan Type to activate the Multi Scan.

- **Transceiver Operation**

- **Activating Scan**

1. Press the **PF Scan** key.

The transceiver starts scanning.

The “Scan” and “↻” icon appear on the LCD.

- **Deactivating Scan**

1. Press the **PF Scan** key during scan.

The “↻” icon disappears and the scan ends.

- **Configuration using KPG-89D**

- Configuring the Scan Type (Refer to FPRG 6.9.10 Scan Type.)
- Assigning functions to the **PF** keys (Refer to FPRG 6.8 Key Assignment.)

23.4 List Scan

The transceiver scans the Zone CH/GID configured in the Scan List Table.

The following CH/GIDs are added to the Scan List.

- A CH/GID that is in the Zone that is added to the Scan List Table.
- A CH/GID that is added using the **PF Scan Del/Add** key

The transceiver scans the Priority Channel even if no Priority Channel is configured in the selected Zone.

You must select “List” in the Scan Type to make the List Scan.

■ Transceiver Operation

● Activating Scan

1. Press the **PF Scan** key.

The transceiver starts scanning.

The “Scan n” and “↻” icon appear on the LCD. The Zone number in the Scan List is entered for “n”.

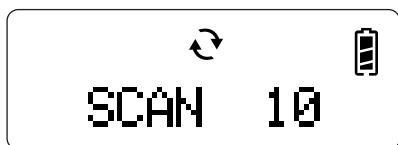

TK-2180/ 3180

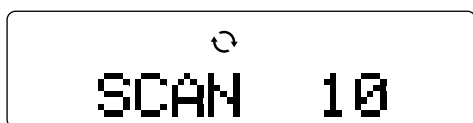

TK-7180/ 8180

● Deactivating Scan

1. Press the **PF Scan** key during scan.

The “↻” icon disappears and the scan ends.

■ Configuration using KPG-89D

- Configuring the Scan Type (Refer to FPRG 6.9.10 Scan Type.)
- Assigning functions to the **PF** keys (Refer to FPRG 6.8 Key Assignment.)

23.5 Priority Scan

This function allows the transceiver to scan the high priority CH/GID regardless of the configuration in each CH/GID.

The transceiver monitors the Priority Channel even if the transceiver is receiving on the normal channel using Single Scan/ Multi Scan/ List Scan when this function is enabled.

The transceiver scans the Priority Channel in the following conditions.

- When there is no Priority Channel in the selected Zone in the Single Scan.
- When the Priority Channel is present in other than the selected Zone in the Multi Scan.
- When the Priority Channel does not exist in the Zone configured in the Scan List Table.

The transceiver makes Single Scan/ Multi Scan/ List Scan to scan the Priority Channel at the interval time configured in the **Scan Information** window > **Lookback Time A or Lookback Time B**.

You can configure the Priority Channel using KPG-89D.

Table 23-3 Priority Scan Function

Priority Scan	Operation
Fixed	The Channel configured using KPG-89D is configured as the Priority Channel.
Selected	The transceiver scans the Selected Channel as the Priority Channel. You cannot configure the Priority Channel using KPG-89D.
Operator Selectable	The channel selected by the operator is configured as the Priority Channel. A user can change the Priority Channel by pressing and holding the PF Scan key for 2 seconds in the Priority Scan Configuration Mode.

Note:

- ◆ This function allows the transceiver to monitor the presence of a signal on the Priority Channel while receiving a call on a normal Channel during Priority Scan.
- ◆ You cannot configure the Group ID in Trunking system as Priority Channel 1 - 2.
- ◆ The transceiver does not look back at the Priority Channel while pausing scan in Trunking system.

■ Transceiver Operation

● Priority Channel 1

The following “P” icon appears.

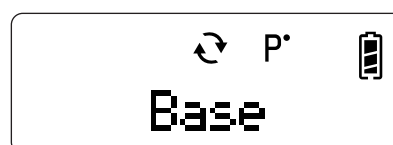

TK-2180/ 3180



TK-7180/ 8180

- **Priority Channel 2**

The following “P.” icon appears.

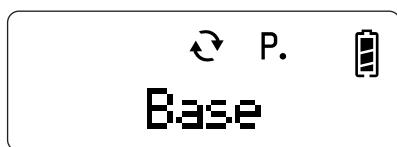

TK-2180/ 3180

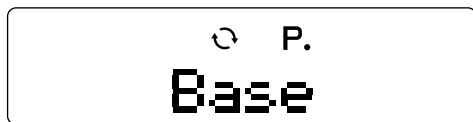

TK-7180/ 8180

- **Priority Channel 1 and 2**

The following “P:” icon appears.

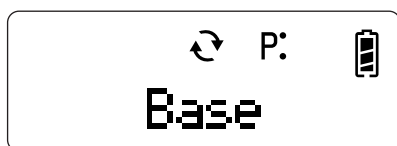

TK-2180/ 3180

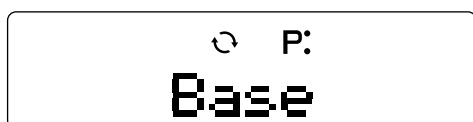

TK-7180/ 8180

23.6 Group Scan

This function allows the transceiver to scan all Group IDs in the selected Zone in a Trunking Systems. A user does not need to press the **PF Scan** key to make the Group Scan.

The following Group IDs are added to the Scan List.

- Group ID that is added using the Scan Add function.
- Group ID that is added using the **PF Scan Del/Add** key

The transceiver performs the Group Scan even if the Single Scan/ Multi Scan/ List Scan Group Scan is made by pressing the **PF Scan** key.

The scan operations is different between the time when making the automatic Group Scan and the time when making the Group Scan in Scan Mode.

- The transceiver does not scan the Priority Channel when making the automatic Group Scan.
- The transceiver scans the Priority Channel when making the Group Scan in Scan Mode.

23.7 Configuring Scan

You can configure the following functions that are relevant to scan using KPG-89D.

- Scan Del/Add
- Scan List
- Scan List Table
- Priority1/ Priority 1 Zone-CH
- Priority2/ Priority 2 Zone-CH
- Revert CH/GID
- Dropout Delay Time
- Dwell Time
- Lookback
- Scan Type
- AC Control
- Priority 1 Temporary Delete/ Add
- Priority 2 Temporary Delete/ Add
- Off-hook Scan (TK-7180/ 8180 only)
- Revert CH/GID Display
- CH/GID Recall
- Priority Channel Stop Tone
- Power-on Scan

23.7.1 Scan Del/Add

This function allows a user to add or delete the CH/GID.

With this function, the user can reliably receive important CH/GID by deleting unnecessary CH/GID to improve the scan speed.

■ Transceiver Operation

- **Adding/deleting CH/GID to/from the Scan List**

- Press the **PF Scan Del/Add** key.
The current CH/GID is deleted from the Scan List when it is already configured in the list. The “▼” icon (right) disappears.
The current CH/GID is added to the Scan List when it is not configured in the list. The “▼” icon (right) appears.

- **Adding/deleting Zone to/from the Scan List**

- Press and hold the **PF Scan Del/Add** key for more than 1 second.
The current Zone is deleted from the Scan List when it is already configured in the list. The “▼” icon (left) disappears.
The current Zone is added to the Scan List when it is not configured in the list. The “▼” icon (right) appears.

Note:

- ◆ The Scan Del/Add function does not work even if the **PF Scan Del/Add** key is pressed.
- ◆ You can make the Scan Del/Add function when scan pauses if the Scan Type is configured to "List".
- ◆ You cannot perform the Zone Del/Add function when the Scan Type is "Single".

■ Configuration using KPG-89D

- Assigning functions to the **PF** keys (Refer to FPRG 6.8 Key Assignment.)

23.7.2 Scan List

This function allows the transceiver to perform a List Scan for each Zone.

You can configure the Scan List Table when the Scan List is enabled.

You can enable/disable the Scan List function using KPG-89D.

Note: You can use this function when the Scan Type is configured to "List Scan".

■ Configuration using KPG-89D

- Configuring the Scan List (Refer to FPRG 6.2.13 Scan List.)

23.7.3 Scan List Table

This function allows a user to select the Zone used for the Scan List. Check the checkbox of the Zone that is scanned with the List Scan.

■ Configuration using KPG-89D

- Configuring the Scan List Table (Refer to FPRG 6.2.15 **Scan List Table** window.)

23.7.4 Priority 1/ Priority 1 Zone-CH

This function allows you to configure the high priority Zone-Channels. You can configure the following functions for Priority 1.

Table 23-4 Priority 1 Operation

Priority 1	Operation
None	No channel is configured as the Priority 1.
Fixed	You can use the Priority 1 Zone-CH configured using the KPG-89D as Priority 1.
Selected	You can configure the selected channel as Priority 1. You cannot select the Priority Channel using the KPG-89D.
Operator Selectable	The channel selected by a user is configured as Priority 1. The transceiver enters Priority Configuration Mode when the PF Scan key is pressed and held for more than 2 seconds.

Note: You cannot configure the Priority 1 Zone-CH when "Selected" is selected in the Priority 1.

■ Transceiver Operation

● Configuring the Priority Channel

1. Select the channel to be configured as the Priority Channel.



TK-2180/ 3180



TK-7180/ 8180

2. Press and hold the **PF Scan** key for more than 2 seconds.

The transceiver enters in Priority Channel Configuration Mode.



TK-2180/ 3180



TK-7180/ 8180

3. Press [C].

The Priority Channel alternates in the following order.

Normal > Priority 1 > Priority2 > Priority1 & 2 > Normal ...



TK-2180/ 3180



TK-7180/ 8180

4. Press [S].

The selected channel is configured as the Priority Channel and the display returns to the channel display.



TK-2180/ 3180



TK-7180/ 8180

■ Configuration using KPG-89D

- Configuring the Priority 1 (Refer to FPRG 6.9.1 Priority 1.)
- Configuring the Priority 1 Zone-CH (Refer to FPRG 6.9.3 Priority 1 Zone-CH.)

23.7.5 Priority 2/ Priority 2 Zone-CH

This function allows you to configure the high priority Zone/Channels. You can configure the following functions for Priority 2.

Table 23-5 Priority 2 Operation

Priority 2	Operation
None	No channel is configured as the Priority 2.
Fixed	You can use the Priority 2 Zone-CH configured using the KPG-89D as Priority 2.

Priority 2	Operation
Selected	You can configure the selected channel as Priority 2. You cannot select the Priority 2 using the KPG-89D.
Operator Selectable	The channel selected by a user is configured as Priority 2. The transceiver enters Priority Configuration Mode when the PF Scan key is pressed and held for more than 2 seconds. (Refer to 23.7.4 Priority 1/ Priority 1 Zone-CH.)

Note: You cannot configure the Priority 2 Zone - CH when "Selected" is selected in the Priority 2.

■ Configuration using KPG-89D

- Configuring the Priority 2 (Refer to FPRG 6.9.2 Priority 2.)
- Configuring the Priority 2 Zone-CH (Refer to FPRG 6.9.4 Priority 2 Zone-CH.)

23.7.6 Revert CH/GID

This function allows you to configure the Zone-CH/GID that is transmitted when the PTT switch is pressed during scan.

You can configure the Revert CH/GID using KPG-89D. The Revert CH/GID function works as below.

Table 23-6 Revert CH/GID Operation

Configuration	During Scan	While Scan Pauses
Last Called	The last received Zone-CH/GID	The Zone-CH/GID on which the transceiver pauses scan
Last Used	The last used Zone-CH/GID	The Zone-CH/GID on which the transceiver pauses scan
Selected	The last selected Zone-CH/GID before activating scan	
Selected + Talk Back	The last selected Zone-CH/GID before activating scan	The Zone-CH/GID on which the transceiver pauses scan
Priority 1	Priority 1 Channel	
Priority 1 + Talkback	Priority 1 Channel	The Zone-CH/GID on which the transceiver pauses scan
Priority 2	Priority 2 Channel	
Priority 2 + Talkback	Priority 2 Channel	The Zone-CH/GID on which the transceiver pauses scan

Note: The next Zone-CH/GID of the Last Called Zone-CH/GID or the Last Used Zone-CH/GID is stored even if the transceiver is turned OFF. In this case, the Revert CH/GID is also stored.

- The last received CH/GID
- The last used CH/GID

■ Configuration using KPG-89D

- Configuring the Revert CH/GID (Refer to FPRG 6.9.5 Revert CH/GID.)

23.7.7 Dropout Delay Time

Dropout Delay Time is the time from when the received signal ends to when the transceiver resumes scan.

The transceiver pauses scan when receiving a call during scan. The transceiver resumes scan after receiving the CH/GID.

The transceiver resumes scan when the following conditions are met.

There is no signal to receive.

QT/DQT does not match.

Group ID does not match.

The transceiver activates the Talkback function during the Dropout Delay Time according to the Revert CH/GID configuration.

When the transceiver pauses scan during the Dropout Delay Time, the channel on which the scan pauses is monitored as the Priority Channel 1/ 2 when it is not configured as the Priority Channel.

You can configure the Dropout Delay Time using KPG-89D.

Note: While scan is paused on a channel, pressing the **PTT** switch will transmit on the current Zone-CH/GID (Talkback operation).

■ Configuration using KPG-89D

- Configuring the Dropout Delay Time (Refer to FPRG 6.9.6 Dropout Delay Time.)

23.7.8 Dwell Time

Scan pauses when the **PTT** switch is pressed during scan. The Dwell Time is the time from when the **PTT** switch is released to when the transceiver resumes scan.

The transceiver activates the Talkback function during the Dwell Time according to the Revert CH/GID configuration.

When the transceiver pauses scan during the Dwell Time, the channel on which the scan pauses is monitored as the Priority Channel 1/ 2 when it is not configured as the Priority Channel.

Note: While scan is paused on a channel, pressing the **PTT** switch will transmit on the current Zone-CH/GID (Talkback operation).

■ Configuration using KPG-89D

- Configuring the Dwell Time (Refer to FPRG 6.9.7 Dwell Time.)

23.7.9 Lookback

This function allows the transceiver to receive the Priority Channel at a certain period when the manual scan pauses on the normal channel if the Priority Channel is configured in the transceiver.

The transceiver selects the time period to scan the Priority Channel (Lookback Time A or Lookback Time B) according to the receive status of the Priority Channel.

■ Lookback Time A

This is the duration from the time when the Priority Scan pauses since no carrier is selected in the Priority Channel to the time when the transceiver resumes the Priority Scan from a normal channel. The Lookback Time A must be shorter than Lookback Time B since the transceiver may receive a call on the Priority Channel.

■ Lookback Time B

This is the duration from the time when the Priority Scan pauses since the Carrier in the Priority Channel does not match own QT/DQT to the time when the transceiver resumes the Priority Scan from a Normal Channel.

■ Configuration using KPG-89D

- Configuring the Lookback Time A (Refer to FPRG 6.9.8 Look Back Time A.)
- Configuring the Lookback Time B (Refer to FPRG 6.9.8 Look Back Time B.)

23.7.10 Scan Type

You can configure the Scan Type when manually entering scan by pressing the **PF Scan** key. (Refer to [23.2 Single Scan](#), [23.3 Multi Scan](#), [23.4 List Scan](#).)

■ Configuration using KPG-89D

- Configuring the Scan Type (Refer to FPRG 6.9.10 Scan Type.)

23.7.11 AC Control

This function allows a user to activate the Carrier Squelch after deactivating the QT/DQT on the Priority Channel during Priority Scan. The user can quickly jump to the Priority Channel since the transceiver does not need to check the QT/DQT.

The user can hear conversations on the Priority Channel even if another QT/DQT group is using the same Priority Channel.

■ Configuration using KPG-89D

- Configuring the AC Control (Refer to FPRG 6.9.11 AC Control.)

23.7.12 Priority 1 Temporary Delete/Add

This function allows a user to temporarily delete the Priority Channel 1 by pressing the **PF Scan Del/Add** key when scan pauses on Priority Channel 1 in Scan Mode.

■ Configuration using KPG-89D

- Configuring the Priority 1 Temporary Delete function (Refer to FPRG 6.9.12 Priority 1 Temporary Delete/Add.)

23.7.13 Priority 2 Temporary Delete/Add

This function allows a user to temporarily delete the Priority Channel 2 by pressing the **PF Scan Del/Add** key when scan pauses on Priority Channel 2 in Scan Mode.

■ Configuration using KPG-89D

- Configuring the Priority 2 Temporary Delete function (Refer to FPRG 6.9.13 Priority 2 Temporary Delete/Add.)

23.7.14 Off-hook Scan

(TK-7180/ 8180 only)

This function allows you to configure the scan operation in conjunction with the Mic hook status. You can configure the scan operation as below.

Table 23-7 Off-hook Scan Operation

Off-hook Scan	Operation
Check (Enable)	The transceiver activates scan when the PF Scan key is pressed regardless of the status of the microphone.
Uncheck (Disable)	The transceiver activates scan when the PF Scan key is pressed if the microphone is in On-hook status. Scan does not start when the microphone is Off-hook. Scan pauses on the Revert CH/GID pauses when switching the Scan Mode from On-hook to Off-hook. The repeater resumes scan when the microphone returns to the On-hook position.

■ Configuration using KPG-89D

- Configuring the Off-hook Scan (Refer to FPRG 6.9.14 Off-hook Scan.)

23.7.15 Revert CH/GID Display

This function allows the transceiver to display the Revert Zone-CH/GID on the display during scan.

■ Configuration using KPG-89D

- Configuring the Revert CH/GID Display (Refer to FPRG 6.9.15 Revert CH/GID Display.)

23.7.16 CH/GID Recall

This function allows the transceiver to move to the Last Called Zone-CH/GID when the **PF CH/GID Recall** key is pressed during scan. A user can move to the last received Zone-CH/GID when receiving a call during scan while he/she is away from the transceiver.

Note:

- ◆ When the **PF CH/GID Recall** key is pressed while no signal is received after scan starts, the transceiver moves to the Scan Start CH/GID.
- ◆ When the CH/GID Recall function is enabled, the transceiver does not resume scan even if the Dropout Delay Time or the Dwell Time expires.
- ◆ The CH/GID Recall function is disabled when changing the CH/GID. The transceiver resumes scan after the Key Dwell Time expires.
- ◆ The Loooback function will not be activated while performing the CH/GID Recall function.

■ Transceiver Operation

- **The transceiver moves to the Last Called Zone-CH/GID.**
 - Press the **PF CH/GID Recall** key during scan.

The transceiver pauses scan after moving to the last received Zone-CH/GID.

“RCL” appears on the sub display.

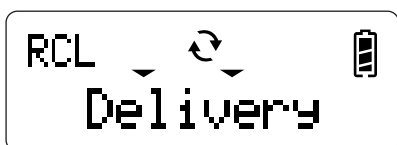

TK-2180/ 3180

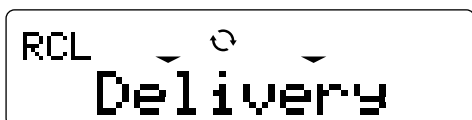

TK-7180/ 8180

● Resuming Scan

- Press the **PF CH/GID Recall** key while the transceiver is moving to the Last Called Zone-CH/GID.

“RCL” on the sub display disappears and the transceiver resumes scan.

■ Configuration using KPG-89D

- Assigning functions to the **PF** keys (Refer to FPRG 6.8 Key Assignment.)

23.7.17 Priority Channel Stop Tone

This function allows the transceiver to emit the Priority Channel Tone when scan pauses on the Priority Channel.

You can enable/ disable the Priority Channel Stop Tone using KPG-89D.

■ Configuration using KPG-89D

- Configuring the Priority Channel Stop Tone (Refer to FPRG 6.9.16 Priority Channel Stop Tone.)

23.7.18 Power-on Scan

This function allows the transceiver to start scan immediately after the transceiver is turned ON.

You can enable/disable the Power-on Scan function using KPG-89D.

■ Configuration using KPG-89D

- Configuring the Power-on Scan (Refer to FPRG 6.9.17 Power-on Scan.)

24 EMERGENCY MODE

The Emergency Mode can be activated by a user or a man down switch in case of emergency. With this function enabled, you can send a message to the dispatcher in emergency situation.

The transceiver enters the Emergency Mode when the **PF Emergency** key is pressed for more than Emergency Key Delay Time. The Emergency Key Delay Time prevents the transceiver from entering Emergency Mode unintentionally.

The transceiver does not enter Emergency Mode in the following conditions.

- The Stun function is enabled.
- The transceiver is in the Transceiver Password Entry Mode.
- The transceiver is in the Remote Mode.
- The transmission CH/GID is not configured.

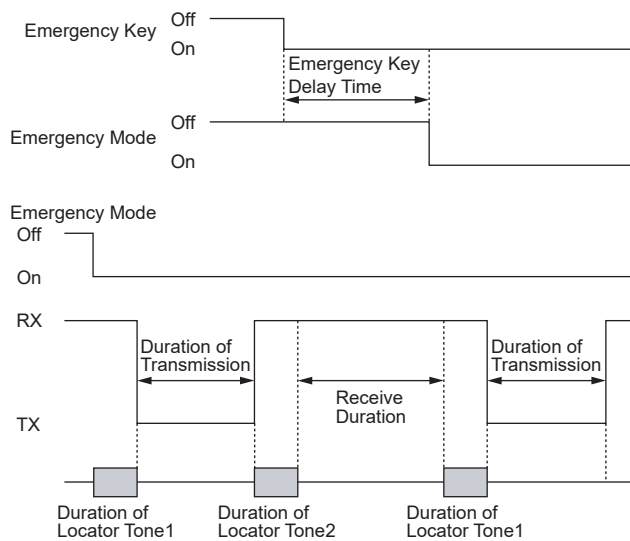

Figure 24-1 Emergency Mode

Note:

- ◆ The microphone sensitivity in Emergency Mode is configured according to the Emergency Mic Sense configuration. (Refer to [1.12 Mic Sense Control](#).)
- ◆ You can assign the **PF Emergency** key to the **AUX/ PF** key for the TK-2180/ 3180. You can assign the key to the Triangle/ AUX IN for the TK-7180/ 8180.
- ◆ The transceiver enters Emergency Mode first when the Triangle key is assigned as the **PF Emergency** key and the Emergency Key Delay Time is disabled.
- ◆ The Busy Channel Lockout function is disabled in Emergency Mode.
- ◆ The transceiver does not decode the Stun Code and Optional Signaling in Emergency Mode.

Transceiver Operation

● Entering to Emergency Mode.

1. Press the **PF Emergency** key for longer than the Emergency Key Delay Time.

● Exiting from Emergency Mode

1. Use one of the following methods to exit from the Emergency Mode.
 - Press the **PF Emergency** key for longer than the Emergency Key Delay Time again.
 - Turn the transceiver OFF.

■ Configuration using KPG-89D

- Assigning functions to the **AUX** key and the **PF** keys (Refer to FPRG 6.8 Key Assignment.)

24.1 Configuring Emergency Mode

You can configure the following functions that are relevant to Emergency Mode using KPG-89D.

- Emergency CH/GID Type
- Emergency Zone-CH/GID
- Emergency Cycle
- Locator Tone 1 Duration
- Transmission Duration
- Locator Tone 2 Duration
- Receive Duration
- Emergency Display
- Emergency Text
- Emergency Mode Type
- Emergency Key Delay Time
- Emergency Mic Sense
- Locator Tone
- Emergency LED
- Background Transmission
- Man Down Switch Type (TK-2180/ 3180 only)
- Man Down Delay Time (TK-2180/ 3180 only)
- Man Down Pre-alert (TK-2180/ 3180 only)
- Man Down Logic Type (TK-2180/ 3180 only)
- Emergency ID
- Emergency DTMF ID
- Emergency Call Fleet
- Emergency Call ID

24.1.1 Emergency CH/GID Type

You can configure the type of CH/GID that operates in Emergency Mode.

You can configure the Emergency Channel Type using KPG-89D. The following Emergency CH/GID Types are available.

Table 24-1 Emergency CH/GID Type Operation

Emergency CH/GID Type	Operation
Selected	The transceiver transmits/receives using the Selected CH/GID when it enters Emergency Mode.
Fixed	The transceiver transmits/receives using the Zone-CH/GID configured in Emergency Zone-CH/GID when it enters Emergency Mode.

■ Configuration using KPG-89D

- Configuring the Emergency CH/GID Type (Refer to FPRG 6.14.1 Emergency CH/GID Type.)

24.1.2 Emergency Zone-CH/GID

This function allows you to configure the Emergency Zone-CH/GID when "Fixed" is selected in Emergency CH/GID Type.

The transceiver moves to the Emergency Zone-CH/GID in the following way.

Table 24-2 Moving to Emergency Zone-CH/ GID

Model	Operation
TK-2180/ 3180	<ul style="list-style-type: none"> Press the PF Emergency key. The switch that is connected to the Man Down Switch Input port becomes active.
TK-7180/ 8180	<ul style="list-style-type: none"> Press the PF Emergency key. Enable the Emergency port assigned to AUX input port.

Note: The transceiver does not decode the Stun Code and Optional Signaling in Emergency Mode.

■ Configuration using KPG-89D

- Configuring the Emergency Zone-CH/GID (Refer to FPRG 6.14.2 Emergency Zone-CH/GID.)

24.1.3 Emergency Cycle

This function allows you to configure the time for switching between transmission and reception in Emergency Mode.

You can configure the Emergency Cycle using KPG-89D. The following Emergency Cycle operations are available.

Table 24-3 Emergency Cycle Operation

Emergency Cycle	Operation
1 - 200	The transceiver repeats "automatic transmission start tone" > "automatic transmission" > "automatic transmission end tone" > "automatic reception" for configured times and exits from Emergency Mode.
Infinite	The transceiver keeps alternating transmission and reception until the PF Emergency key is pressed again or the transceiver is turned OFF.

■ Configuration using KPG-89D

- Configuring the Emergency Cycle (Refer to FPRG 6.14.3 Emergency Cycle.)

24.1.4 Locator Tone 1 Duration

The Locator Tone 1 Duration notifies a user that the transceiver started the automatic transmission in Emergency Mode.

The Tone sounds when the transceiver switches between transmission and reception while it repeats the automatic transmission and reception.

A user can easily recognize that the transceiver is about to transmit the Emergency Call when the tone sounds. You can also use the Tone to locate a user who is in an emergency situation.

You can configure the Locator Tone 1 Duration using KPG-89D.

■ Configuration using KPG-89D

- Configuring the Locator Tone 1 Duration (Refer to FPRG 6.14.4 Locator Tone 1 Duration.)

24.1.5 Transmit Duration

The transmission duration is the automatic transmission time in Emergency Mode.

The transceiver performs automatic reception in Emergency Mode after the Transmit Duration Time expires.

You can configure the Transmit Duration using KPG-89D.

■ Configuration using KPG-89D

24 EMERGENCY MODE

- Configuring the Transmit Duration (Refer to FPRG 6.14.5 Transmit Duration.)

24.1.6 Locator Tone 2 Duration

The Locator Tone 2 Duration notifies a user that the transceiver has ended automatic transmission in the Emergency Mode and has returned to the receiving mode.

The tone sounds when the transceiver switches between transmission and reception while it repeats automatic transmission and reception.

A user can easily recognize that the transceiver is about to enter the receive mode in the Emergency Call with the Tone. The user can also use the Tone to locate the user who is in an emergency situation.

You can configure the Locator Tone 2 Duration using KPG-89D.

■ Configuration using KPG-89D

- Configuring the Locator Tone 2 Duration (Refer to FPRG 6.14.6 Locator Tone 2 Duration.)

24.1.7 Receive Duration

The Receive Duration is the duration for automatically receiving in the Emergency Mode.

The transceiver returns to the Emergency Automatic Transmission Mode after the Receive Duration expires.

You can configure the Receive Duration using KPG-89D.

■ Configuration using KPG-89D

- Configuring the Receive Duration (Refer to FPRG 6.14.7 Receive Duration.)

24.1.8 Emergency Display

You can configure the items to be displayed in the Emergency Mode.

You can only configure the Emergency Display using KPG-89D.

Table 24-4 Emergency Display Operation

Emergency Display	Operation
Selected	The current Selected CH/GID appears even when the transceiver enters the Emergency Mode.
Text	A pre-programmed message configured as the Emergency Text appears during the Emergency Mode.

Note: No icon appears in Emergency Mode.

■ Configuration using KPG-89D

- Configuring the Emergency Display (Refer to FPRG 6.14.8 Emergency Display.)

24.1.9 Emergency Text

The Emergency Text is the text displayed on the main display when "Text" is selected for the Emergency Display.

You can configure the Emergency Text using KPG-89D.

■ Configuration using KPG-89D

- Configuring the Emergency Text (Refer to FPRG 6.14.9 Emergency Text.)

24.1.10 Emergency Mode Type

You can configure the transceiver to emit the received voice

You can only configure the Emergency Mode Type using KPG-89D.

Table 24-5 Emergency Mode Type Operation

Emergency Mode Type	Operation
Silent	The transceiver mutes voice in Emergency Mode.
Audible	The transceiver emits the received voice in Emergency Mode.

■ Configuration using KPG-89D

- Configuring the Emergency Mode Type (Refer to FPRG 6.14.10 Emergency Mode Type.)

24.1.11 Emergency Key Delay Time

You can configure the duration from the time when the **PF Emergency** key is pressed to the time when the transceiver enters the Emergency Mode. The transceiver enters the Emergency Mode when the **PF Emergency** key is pressed for the Emergency Key Delay Time. This delay time prevents the transceiver from unintentionally entering this mode.

You can configure the Emergency Key Delay Time using KPG-89D.

■ Configuration using KPG-89D

- Configuring the Emergency Key Delay Time (Refer to FPRG 6.14.11. Emergency Key Delay Time.)

24.1.12 Emergency Mic Sense

You can configure the microphone gain of the transceiver in the Emergency Mode using KPG-89D. (Refer to [1.12 Mic Sense Control](#).)

■ Configuration using KPG-89D

- Configuring the Emergency Mic Sense function (Refer to FPRG 6.14.12 Emergency Mic Sense.)

24.1.13 Locator Tone

You can configure the volume level of the Locator Tone when the transceiver is in the Emergency Mode.

You can configure the Locator Tone using KPG-89D.

Table 24-6 Locator Tone Operation

Locator Tone	Operation
Off	The transceiver does not emit the Locator Tone.
0 - 31	You can fix the volume level of the Locator Tone. Higher values result in greater volume.
Current	The transceiver configures the Locator Tone volume in conjunction with the Volume Control.
Selectable	The tone volume varies in conjunction with the PF Fixed Volume key.

Note: The transceiver does not emit the Locator Tone when the Emergency Mode Type is "Silent".

■ Configuration using KPG-89D

- Configuring the Locator Tone (Refer to FPRG 6.7.2 Common-Page 2 tab - Locator Tone.)

24.1.14 Emergency LED

This function allows the transceiver to turn On the TX LED and BUSY LED when the transceiver transmits in the Emergency Mode.

You can configure the LED to light using KPG-89D.

■ Configuration using KPG-89D

- Configuring the Emergency LED (Refer to FPRG 6.14.3 Emergency LED.)

24.1.15 Background Transmission

This function allows the transceiver to include with the transmitted voice a 1630 Hz tone emitted every second in the Emergency Mode.

The transceiver does not mute since the tone is transmitted with lower deviation than the voice. The receiving party can easily recognize that the caller is in Emergency Mode since the tone is extended during voice communication.

You can configure the Background Transmission using KPG-89D.

■ Configuration using KPG-89D

- Configuring the Background Transmission (Refer to FPRG 6.14.14 Background Transmission.)

24.1.16 Man Down Switch Type

(TK-2180/ 3180 only)

The Man Down Switch Type must be enabled when the internal Man Down Switch is installed.

You can configure the Man Down Switch Type using KPG-89D.

■ Configuration using KPG-89D

- Configuring the Man Down Switch Type (Refer to FPRG 6.14.15 Man Down Switch Type.)

24.1.17 Man Down Delay Time

(TK-2180/ 3180 only)

The Man Down Delay Time is the duration from the time when the Man Down Switch is switched On to the time when the Man Down Switch is enabled.

The transceiver enters the Emergency Mode when the Man Down Switch is enabled after this timer expires. You can use the Man Down Delay Time to prevent the Emergency function from being activated unintentionally.

You can configure the Man Down Delay Time using KPG-89D.

■ **Configuration using KPG-89D**

- Configuring the Man Down Delay Time (Refer to FPRG 6.14.16 Man Down Delay Time.)

24.1.18 Man Down Pre-alert

(TK-2180/ 3180 only)

The Man Down Pre-alert is the alert tone beeping from the time when Man Down Switch is switched On to the time when the Man Down Switch function is enabled.

When the Man Down Switch is enabled unintentionally, the transceiver emits the Pre-alert before activating the Emergency function to notify the user that the switch is switched On.

You can configure the Man Down Delay Time using KPG-89D. The Man Down Pre-alert duration must be shorter than the Man Down Delay Time.

■ **Configuration using KPG-89D**

- Configuring the Man Down Pre-alert (Refer to FPRG 6.14.17 Man Down Pre-alert.)

24.1.19 Man Down Logic Type

(TK-2180/ 3180 only)

You can configure the logic of the Man Down Switch (External Switch).

You can configure the Man Down Logic Type using KPG-89D.

Table 24-7 Man Down Logic Type Operation

Man Down Logic Type	Operation
Active Low	The transceiver detects that the Man Down Switch is enabled when the Input port becomes low.
Active High	The transceiver detects that the Man Down Switch is enabled when the Input port becomes high.

■ **Configuration using KPG-89D**

- Configuring the Man Down Logic (Refer to FPRG 6.14.18 Man Down Logic Type.)

24.1.20 Emergency ID

This function allows you to configure the code to be sent or the control type each time the transceiver starts the automatic transmission/ reception in the Emergency Mode.

You can configure the Emergency ID using KPG-89D. The following Emergency IDs are available.

Table 24-8 Emergency ID Operation

Emergency ID	Operation
None	The transceiver transmits/receives according to the configuration in KPG-89D.
DTMF	The transceiver transmits/receives according to the configuration in KPG-89D. The transceiver sends the DTMF code configured first at the Emergency DTMF ID.
FleetSync	The transceiver transmits/receives according to the configuration in KPG-89D. The transceiver sends the Emergency Call Fleet first and the FleetSync SelCall ID configured in the Emergency Call ID.
ANI Board	The transceiver transmits/receives in conjunction with the ANI board control.

Note: You can configure the ANI board only if the “ANI Board” is selected in the Extended Function.

■ **Configuration using KPG-89D**

- Configuring the Emergency ID (Refer to FPRG 6.14.19 Emergency ID.)

24.1.21 Emergency DTMF ID

This function allows you to configure the DTMF code to be sent first in the Emergency Mode when “DTMF” is selected in the Emergency ID.

You can configure the Emergency DTMF ID using KPG-89D.

■ **Configuration using KPG-89D**

- Configuring the Emergency DTMF ID (Refer to FPRG 6.14.20 Emergency DTMF ID.)

24.1.22 Emergency Call Fleet

This function allows you to configure the Call Fleet to be sent first in the Emergency Mode when “FleetSync” is selected in the Emergency ID.

You can configure the Emergency Call Fleet using KPG-89D.

■ Configuration using KPG-89D

- Configuring the Emergency Call Fleet (Refer to FPRG 6.14.21 Emergency Call Fleet.)

24.1.23 Emergency Call ID

This function allows you to configure the Call ID to be sent first in the Emergency Mode when “FleetSync” is selected in the Emergency ID.

You can configure the Emergency Call ID using KPG-89D.

■ Configuration using KPG-89D

- Configuring the Emergency Call ID (Refer to FPRG 6.14.22 Emergency Call ID.)

You can perform data communications by using the FleetSync function or by connecting an external modem or MDT to the transceiver.

25.1 Data Communications Configuration

You can configure the following data communication functions using KPG-89D.

- Data
- Data Zone-CH/GID
- Data CH/GID Dwell Time
- Data Transmission with QT/DQT
- COM port
- Data Override (TK-7180/ 8180 only)

25.1.1 Data

You can select the CH/GID to be used for data communications or voice communications. The transceiver mutes on the Data CH/GID.

You can configure the CH/GID to be used for data communication using KPG-89D.

■ Configuration using KPG-89D

- Configuring the Data to channel (Refer to FPRG 6.3.16 Data.)
- Configuring the Data to Group ID (Refer to FPRG 6.6.15 Data.)

25.1.2 Data Zone-CH/GID

This function is used to separate the CH/GID for data communications from the CH/GID for voice communications.

The transceiver sends the message after moving to the Data Zone-CH/GID configured to the selected Zone when the following items are configured and the transceiver sends Status Message, Short Message, or Long Message.

- Status Message on Data Zone-CH/GID
- Short Message on Data Zone-CH/GID
- Long Message on Data Zone-CH/GID

When the transceiver completes transmitting, it returns to the previous Zone-CH/ GID after the Data CH/GID Dwell Time expires.

You can configure the Data Zone-CH/GID using KPG-89D.

■ Configuration using KPG-89D

- Configuring the Status Message on Data Zone-CH/GID function (Refer to FPRG 6.12.3 Parameter tab - Status Message on Data Zone-CH/GID.)
- Configuring the Short Message on Data Zone-CH/GID function (Refer to FPRG 6.12.3 Parameter tab - Short Message on Data Zone-CH/GID.)
- Configuring the Long Message On Data Zone-CH/GID function (Refer to FPRG 6.12.3 Parameter tab - Long Message On Data Zone-CH/GID.)

25.1.3 Data CH/GID Dwell Time

This function allows you to configure the delay time from the time when the PF DTC port or PF Data PTT port in PF AUX Input port becomes inactive to the time when the transceiver returns to the Voice CH/GID. This function is used when the external device waits for an ACK from the transceiver.

You can configure the Data CH/GID Dwell Time using KPG-89D.

■ Configuration using KPG-89D

- Configuring the Data Dwell Time (Refer to FPRG 6.15.3 AUX tab - Data Dwell Time.)

25.1.4 Data Transmission with QT/DQT

This function allows the transceiver to use the QT/DQT configured to channels for the data transmission.

This function is applicable to Conventional Group Channels that handle Status/Short Data/ Long Data Messages. This function is also available to make data communications using an external device.

While the repeater uses the QT/DQT, the transceiver performs data communications with QT/DQT when Data Transmission with QT/DQT is enabled.

It performs data communications without using the QT/DQT when this function is disabled.

You can configure the Data Transmission with QT/DQT function using KPG-91D

■ Configuration using KPG-89D

- Configuring the Data Transmission with QT/DQT (Refer to FPRG 6.12.3 Parameter tab - Data Transmission with QT/DQT.)

25.1.5 COM port

The COM port is a serial communication port. You can select the usage of each serial communication port.

The TK-7180/ 8180 has 3 external communication ports (COM 0 - 2) and TK-2180/ 3180 has 2 ports (COM 0 - 1). (Refer to 7 Communication Port.)

You can configure the COM port using KPG-89D.

■ Configuration using KPG-89D

- Configuring the COM port (Refer to FPRG 6.7.3 Common-Page 3 tab - COM port 1 - 3.)

25.1.6 Data Override

(TK-7180/ 8180 only)

You can select the priority of either voice or data communications. This Data Override Function can be used to send the GPS data periodically during voice communications.

You can configure the Data Override function using KPG-89D.

Table 25-1 Data Override Operation

Data Override	Operation
Check (Enable)	<p>This option gives higher priority to the external device for data communications. If the transceiver receives the transmission requests from the external device, it will always cancel the current option and change to make data communication.</p> <p>The transceiver moves to the Data CH/GID if the Data CH/GID is configured.</p> <ul style="list-style-type: none"> • PF Ext. PTT (Data) port • PF Data PTT port • CH/GID Select A • CH/GID Select B • CH/GID Select C • CH/GID Select D • DTC • Home CH/GID <p>“REMOTE CTRL” appears on the main display when the transceiver is controlled by external devices. In this case, a user cannot use any keys on the transceiver other than the Power switch and the PF Emergency key.</p>

Data Override	Operation
Uncheck (Disable)	<p>The transceiver key control has priority. If the transceiver receives the transmission request on the PF Ext. PTT port or PF Data PTT port, it ignores the transmission request.</p> <ul style="list-style-type: none"> • PF Ext. PTT (Data) port • PF Data PTT port • CH/GID Select A • CH/GID Select B • CH/GID Select C • CH/GID Select D • DTC • Home CH/GID

Note: When the transceiver is transmitting or in Emergency Mode, it is not controlled by external devices even if the Data Override function is enabled.

■ Configuration using KPG-89D

- Configuring the Data Override function (Refer to FPRG 6.15.3 AUX tab - Data Override.)

26 FUNCTION PORT

The TK-7180/ 8180 transceiver has Programmable Function ports (AUX Input/AUX Output).

The following input/output ports are assigned to the D-sub 25-pin connector on the back panel.

Table 26-1 Assigning Signals to the D-sub 25-pin Connector

Pin No.	Signal name	Input/Output	Description
4	AUX I/O 9	Input/Output	Auxiliary Input/Output 9 : Active Low with 47 kΩ pull-up to 5 V
8	AUX I/O 8	Input/Output	Auxiliary Input/Output 8 : Active Low with 47 kΩ pull-up to 5 V
12	AUX I/O 7	Input/Output	Auxiliary Input/Output 7 : Active Low with 47 kΩ pull-up to 5 V
13	AUX I/O 6	Input/Output	Auxiliary Input/Output 6 : Active Low with 47 kΩ pull-up to 5 V
15	AUX OUT 2	Output	Auxiliary Output 2 : Active Low Open collector (500 mA max)
16	AUX OUT 1	Output	Auxiliary Output 1 : Active Low Open collector (500 mA max)
20	AUX I/O 5	Input/Output	Auxiliary Input/Output 5 : Active Low with 47 kΩ pull-up to 5 V
21	AUX I/O 4	Input/Output	Auxiliary Input/Output 4 : Active Low with 47 kΩ pull-up to 5 V
22	AUX I/O 3	Input/Output	Auxiliary Input/Output 3 : Active Low with 47 kΩ pull-up to 5 V
23	AUX I/O 2	Input/Output	Auxiliary Input/Output 2 : Active Low with 47 kΩ pull-up to 5 V

Pin No.	Signal name	Input/Output	Description
24	AUX I/O 1	Input/Output	Auxiliary Input/Output 1 : Active Low with 47 kΩ pull-up to 5 V

26.1 Assigning Functions to the Auxiliary Input Ports

You can assign one of the functions to the AUX Input port using KPG-89D.

26.1.1 Data PTT

The Data PTT is the transmission request PTT port for data communications.

This terminal changes the channel of the transceiver to Data Zone-CH/GID to start the transmission.

The transceiver moves to the Data CH/GID to start the transmission when the PF Data PTT port becomes low.

The transmission ends when the Data PTT port becomes high. The transceiver stands by on the data channel during the Data CH/GID Dwell Time. The transceiver returns to the voice channel after the Data CH/GID Dwell Time expires.

The Data PTT has the priority when the Data Override function is enabled. (Refer to 25.1.6 Data Override.)

You can configure the following functions to the Data PTT port.

Table 26-2 Data PTT Configuration

Data PTT	Configuration
Modulation Line	<p>You can configure the modulation line for the PF Data PTT port. The following modulation lines are available.</p> <ul style="list-style-type: none"> • Mic (the audio line of the Mic located on the front of the transceiver) • MI2 Line (the audio modulation line of the D-sub connector located on the rear of the transceiver) • DI Line (the data modulation line of the D-sub connector) <p>The normal modulation line is the DI line.</p>
w/QT/DQT	<p>You can configure the QT/DQT configured to the Conventional Group channel to be extended when the transceiver transmits the code using the Data PTT port. Normally, the QT/DQT are also modulated at the same time.</p>

Data PTT	Configuration
w/STE	You can configure the STE (Squelch Tail Eliminator) to be transmitted after transmitting the QT/DQT code configured in the Conventional Group channel using the Data PTT port. Normally, it is configured to transmit the STE.

Note:

- ◆ The ARQ Mode is not available while the transceiver is transmitting with the Data PTT in Trunking system.
- ◆ You cannot use the PF Data PTT port, PF Ext. PTT (Voice) port, and the PF Ext. PTT (Data) port at the same time.
- ◆ The transceiver mutes on the Data CH/GID. The transceiver does not transmit the PTT ID even if the PTT ID is configured.

26.1.2 External PTT (Voice)

External PTT (Voice) is the PTT port for voice channels.

This port is used for the transmission request from a headset or external microphone.

The transceiver starts transmitting when the Ext. PTT (Voice) port becomes low.

The transceiver ends transmission when the Ext. PTT (voice) port becomes high. If the CH/GID is the Data CH/GID when the port becomes high, the transceiver moves to the lowest Voice CH/GID in the current Zone and transmits.

You can configure the following functions to the Ext. PTT (Voice) port.

Table 26-3 Ext. PTT (Voice) Port Configuration

External PTT (Voice)	Configuration
Modulation Line	<p>You can configure the modulation line for the PF Ext. PTT (Voice) port. The following modulation lines are available.</p> <ul style="list-style-type: none"> • Mic (the audio line of the Mic located on the front of the transceiver) • MI2 Line (the audio modulation line of the D-sub connector located on the rear of the transceiver) • DI Line (the data modulation line of the D-sub connector) <p>The default modulation line is the MI2 line.</p>
w/QT/DQT	You can configure the QT/DQT for the Conventional Group channel to be mixed when the transceiver transmits the code from the PF Ext. PTT (Voice) port. Normally, the QT/DQT is mixed when it is modulated.
w/STE	You can configure the STE (Squelch Tail Eliminator) to be transmitted after transmitting the QT/DQT code for the Conventional Group channel using the PF Ext. PTT (Voice) port. Normally, it is configured to transmit the STE.

Note:

- ◆ You cannot use the PF Data PTT port, PF Ext. PTT (Voice) port, and the PF Ext. PTT (Data) port at the same time.
- ◆ The transceiver also transmits the PTT ID if the PTT ID is configured to the CH/GID.

26.1.3 External PTT (Data)

The Data PTT is the PTT port for data communications.

You can use the port as below.

■ Using the External PTT (Data) Port with DTC

The External PTT port is used for the transmission request in ARQ Mode if it is used with the DTC.

After activating the DTC, data is transmitted by activating the Ext. PTT (Data) port.

■ Using the External PTT (Data) Port with CH/GID Select A-D

The External PTT port is used to request PTT for an external data communication device if it is used without using the Direct Channel (DTC) function. The transceiver transmits on the current Data CH/GID without moving to the Data Zone-CH/GID.

The Ext. PTT (Data) port has priority when the Data Override function is enabled. ([Refer to 25.1.6 Data Override.](#))

The transceiver starts transmitting when the Ext. PTT (Data) port becomes low.

The transceiver ends transmission when the Ext. PTT (Data) port becomes high. The transceiver does not transmit if the current CH/GID is Voice CH/GID.

You can configure the following functions to the Ext. PTT (Data) port.

Table 26-4 Ext. PTT (Data) Port Configuration

External PTT (Voice)	Configuration
Modulation Line	<p>You can configure the modulation line for the Ext. PTT (Data) port. The following modulation lines are available.</p> <ul style="list-style-type: none"> • Mic (the audio line of the Mic located on the front of the transceiver) • MI2 Line (the audio modulation line of the D-sub connector located on the rear of the transceiver) • DI Line (the data modulation line of the D-sub connector) <p>The normal modulation line is the DI line.</p>
w/QT/DQT	You can configure the QT/DQT for the Conventional Group channel to be mixed when the transceiver receives the code using the Ext. PTT (Data) port. Normally, the QT/DQT is mixed.

26 FUNCTION PORT

External PTT (Voice)	Configuration
w/STE	You can configure the STE (Squelch Tail Eliminator) to be transmitted after transmitting the QT/DQT code configured in the Conventional Group channel using the PF Ext. PTT (Data) port. Normally, the STE is transmitted.

Note:

- ◆ You cannot use the PF Data PTT port, PF Ext. PTT (Voice) port, and the PF Ext. PTT (Data) port at the same time.
- ◆ The transceiver mutes on the Data CH/GID. The transceiver does not transmit the PTT ID even if the PTT ID is configured.

26.1.4 CH/GID Select A-D

This Remote CH/GID List port is to be used with the Remote CH/GID List.

You can configure the port in the order of the Configure CH/GID Select A > CH/GID Select B > CH/GID Select C > CH/GID Select D.

26.1.5 DTC

This port allows the transceiver to move to the Data Zone-CH/GID for data communications and activate ARQ Mode.

When performing data transmission in a LTR Trunking System, the transceiver is normally required to link to a repeater prior to each data transmission. Therefore, the data transmission may fail when the system is busy and there is no available channel in the repeater. To solve this problem, ARQ Mode allows the transceiver to complete data communications in a Trunking system by making a single link.

The transceiver does not transmit the EOT after the ARQ mode is linked. This function retains the link by using the Hang Time of the repeater while communicating using the ACK signals. With this function, you can use the Air Time effectively.

The transceiver enters ARQ Mode when the PF DTC port becomes low.

The DTC function has priority when the Data Override function is enabled.

Note:

- ◆ During scan, the data channel does not revert by the PTT.
- ◆ When the PF DTC port becomes low, the transceiver moves to the Data CH/GID in the Revert Zone.
- ◆ The DTC is not configured when the PF Data PTT port is configured as the Function Port.
- ◆ You cannot configure the DTC function if the External PTT (Data) port is not configured.

26.1.6 Speaker Mute

The speaker audio output line mutes when this port is used.

The transceiver mutes when the PF Speaker Mute port becomes low. The mute function is disabled when this port becomes high.

26.1.7 Mic Mute

The Mic modulation line mutes when this port is used.

The Mic Line (Front Mic, MI2) mutes when the PF Mic Mute port becomes low. The mute function is disabled when this port becomes high.

26.1.8 External Monitor

This port activates the Monitor function.

The transceiver activates the Monitor function when the PF Ext. Monitor port becomes low. The transceiver disables the Monitor function when the PF Ext. Monitor port becomes high.

Note: You cannot disable the Squelch Off function with the Ext. Monitor port.

26.1.9 External Hook

This port functions the same as the Local Mic Hook.

The transceiver enters the On-hook status when the PF Ext. Hook port becomes low. The microphone switches to the Off-hook status when the port becomes high.

A user can reset the Off-hook Decode, Off-hook Horn Alert, Off Hook Scan, and Optional Signaling in the same way as the Local Mic Hook.

When both the local Mic hook and the PF Ext. Hook are Off-hook, the transceiver is active in the Off-Hook status. If either of them is On, the transceiver is active in the On-hook status.

26.1.10 Emergency

This port allows the transceiver to activate the Emergency function.

You can configure the Emergency Key Delay Time to prevent this port from being activated unintentionally. ([Refer to 24 Emergency Mode.](#))

The transceiver enters the Emergency Mode when the PF Emergency port becomes low. The Emergency Mode operates according to the Emergency Information. ([Refer to 24 Emergency Mode.](#))

26.1.11 AUX In Status Message 1 - 3

This port is used as the trigger port to send the FleetSync Status Message.

The transceiver sends the Status Message to the Target Fleet/ID when the status of the AUX IN changes (High > Low or Low > High).

You can configure 2 Statuses (High > Low, Low > High) to each port since these ports are AUX Input ports. These ports are normally used as the sensor ports for telemetry purposes.

Note: The transceiver does not send the Status Message immediately after it is turned ON since it does not recognize that the status of the AUX Input port assigned to AUX Status Message 1 - 3 has changed.

26.1.12 Display Off

This port becomes active when the external device (KGP-2A) enters Emergency Mode.

The transceiver also enters Emergency Mode when the port becomes active. The transceiver returns to the previous channel when the port becomes inactive.

This port works according to the following conditions.

- Emergency CH/GID
- Emergency Display
- Emergency Text

- Emergency Audio
- Emergency LED

The **PF** key does not work while this port is active.

26.1.13 Data CH/GID Dwell Time

The external device activates the Data PTT/ DTC when performing data communications.

The transceiver moves from the Voice CH/GID to the Data CH/GID. The external device deactivates the Data PTT/DTC port when the data communication completes.

The transceiver stands by on the data channel during the Data CH/GID Dwell Time even if the Data PTT/DTC port becomes inactive. The transceiver returns to the voice channel after the Data CH/GID Dwell Time expires.

26.1.14 Mic Sense

You can adjust the Mic Gain of the MI2 line when the transceiver transmits using the PF Ext. PTT (Voice) port.

26.2 Assigning Functions to AUX

You can assign one of the following functions to the AUX Output port.

You can assign function to the AUX Output port using KPG-89D.

26.2.1 LOK

This port notifies a user that voice communications are active when transmitting in a Trunking system/ Conventional Group.

In a Trunking system, this port becomes active when the transceiver connects to a repeater. Otherwise, it is inactive.

In Conventional Groups, this port becomes active (low) upon transmission. Otherwise, this function is inactive.

There are two types of LOK Logic Signal: Continuous and Pulse. This port always becomes low when "Continuous" is selected. The port becomes active for the first 30 ms, then it returns to open level when "Pulse" is selected.

26.2.2 COR

This port notifies a user that the transceiver is receiving a Carrier.

This port becomes active when receiving a Carrier. Otherwise, this port is inactive.

26.2.3 TOR

This port notifies a user that the transceiver is receiving the GID in a Trunking system and QT/ DQT is matched in Conventional Groups.

This port becomes active when receiving a call with GID in a Trunking system. Otherwise, this port is inactive.

This port becomes active when receiving a carrier on the channel that the QT/DQT is configured in Conventional Groups. Otherwise, this port is inactive.

26.2.4 AUX A

The port output changes in conjunction with the PF AUX A port. A user can control an external device connected to the **PF AUX A** port.

26.2.5 AUX B

The port output changes in conjunction with the PF AUX B port. A user can control an external device connected to the PF AUX B port.

26.2.6 System Busy

This port becomes active when no repeater is available in a Trunking system. Otherwise, this port is inactive.

26.2.7 PTT Out

This port notifies a user that the **PTT** switch is pressed. You can use this function when an optional board or an external device is connected to the transceiver.

This port becomes active when the **PTT** switch is pressed. Otherwise, this port is inactive.

26.2.8 Channel Busy

This port notifies a user that the remote control request from the external device is rejected.

This port becomes active in the following conditions.

Table 26-5 Conditions for the Channel Busy Port to Become Active

Mode	Status
Transmission	All transmissions (including automatic transmission and the transmission using the PTT switch)
Emergency	Emergency Mode

26.2.9 COR or Channel Busy

This port becomes active when the COR port or Channel Busy port is active. When neither of ports is disabled, this port becomes inactive.

You can use this port to connect the KPG-2A or KDS-100 to the transceiver. With this port, you can restrict the transmission request to the KPG-2A or KDS-100 when you do not want the transceiver to be controlled with an external device.

26.2.10 TOR or Channel Busy

This port becomes active when the TOR port or Channel Busy port is active. When either of the ports is disabled, this port becomes inactive.

26.2.11 TXS

This port notifies a user that the transceiver is transmitting.

This port becomes active when the transceiver is transmitting. Otherwise, this port is inactive.

26.2.12 AUX Out Status Message 1 - 3

This port is used to change the status of the transceiver when it receives the FleetSync Status Message.

This port switches the Status of the AUX Out port (High > Low or Low > High) when the received Status Message matches the Status number configured to the port.

You can configure 2 Statuses (High > Low or Low > High) to each port since these ports are AUX Output ports.

This port is normally used to remotely control the transceiver by connecting an external device to the AUX Out.

27 REMOTE CH/GID LIST

This function allows the transceiver to jump to one of 15 Zone-CH/GIDs using the CH/GID Select A - CH/GID Select D ports.

27.1 Jumping to the Specified Zone-CH/GID using the External Device Connected to the Transceiver

The transceiver jumps to the Zone-CH/GID configured in the Remote CH/GID when the status of CH/GID Select A - CH/GID Select D ports becomes low.

The selected CH/GID appears on the display.

Table 27-1 Number in the Remote CH/GID List According to CH/GID Select A - D Port Status

Target CH/GID	AUX Input Port			
	CH/GID Select D	CH/GID Select C	CH/GID Select B	CH/GID Select A
Current CH/GID	High	High	High	High
Remote CH/GID No. 1	High	High	High	Low
Remote CH/GID No. 2	High	High	Low	High
Remote CH/GID No. 3	High	High	Low	Low
Remote CH/GID No. 4	High	Low	High	High
Remote CH/GID No. 5	High	Low	High	Low
Remote CH/GID No. 6	High	Low	Low	High
Remote CH/GID No. 7	High	Low	Low	Low
Remote CH/GID No. 8	Low	High	High	High
Remote CH/GID No. 9	Low	High	High	Low
Remote CH/GID No. 10	Low	High	Low	High

Target CH/GID	AUX Input Port			
	CH/GID Select D	CH/GID Select C	CH/GID Select B	CH/GID Select A
Remote CH/GID No. 11	Low	High	Low	Low
Remote CH/GID No. 12	Low	Low	High	High
Remote CH/GID No. 13	Low	Low	High	Low
Remote CH/GID No. 14	Low	Low	Low	High
Remote CH/GID No. 15	Low	Low	Low	Low

Note: You cannot register the Zone-CH/GID whose the CH/GID data is not configured to the Remote CH/GID List.

■ Configuration using KPG-89D

- Configuring the AUX Input (Refer to FPRG 6.15.2 AUX tab.)
- Configuring the Remote CH/GID List (Refer to FPRG 6.15.3 Remote Zone-CH/GID tab.)

This function allows a user to transmit by speaking into the microphone without using the **PTT** switch.

The user can use this function when the user cannot press the **PTT** switch.

This function is available only in a Conventional Group and the user must wear a headset. The user can use this function only in the TK-2180/ 3180.

If the VOX Function checkbox is checked, the VOX function is activated when the transceiver is turned ON.

Note:

- ◆ You cannot transmit using the VOX function when the transmission is restricted by the Stun function, etc.
- ◆ If the transceiver terminates VOX transmissions due to the TOT, it does not transmit until both of the VOX function and the **PTT** switch are activated again.
- ◆ A user cannot use the VOX function only with the transceiver itself. Although the VOX function activates if the speaker microphone is installed to the transceiver, the proper operation of the function is not guaranteed. The user can use this function properly when the headset is installed to the transceiver.

■ Transceiver Operation

● Enabling the VOX function

1. Press and hold the **PF VOX** key for more than 2 seconds.

The VOX function is activated.

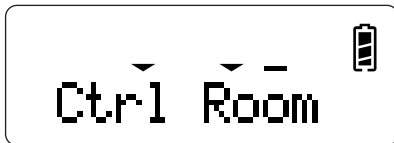

TK-2180/ 3180



TK-7180/ 8180

● Disabling the VOX function

1. Press and hold the **PF VOX** key for more than 2 seconds.

The “—” icon (left) disappears and the VOX function is disabled.

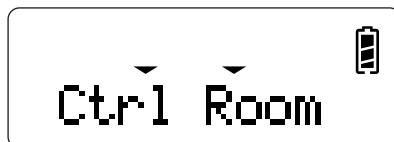

TK-2180/ 3180

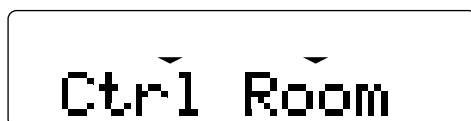

TK-7180/ 8180

Note: The status of the **VOX** function key is stored even if the transceiver is turned OFF.

■ Configuration using KPG-89D

- Assigning functions to the **PF** keys (Refer to FPRG 6.8 Key Assignment.)

28.1 Configuring the VOX Function

You can configure the following functions that can be relevant to VOX Function using KPG-89D.

- VOX Gain Level
- VOX Delay Time
- TX Inhibit while Receiving
- Cancel Operation
- VOX Proceed Tone

28.1.1 VOX Gain Level

The VOX Gain Level is the sensitivity of the microphone.

You can configure the VOX Gain Level using KPG-89D. You can also adjust the VOX Gain Level using the transceiver.

■ Transceiver Operation

1. Press the **PF VOX** key.

The VOX function is activated.

The “—” icon (left) appears and the current VOX Gain Level appears.

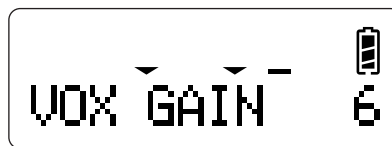

TK-2180/ 3180



TK-7180/ 8180

- Adjust the VOX Gain Level using [B]/ [C], Selector, or [▲]/ [▼].



TK-2180/ 3180



TK-7180/ 8180

- Press [Side 1]/ [▲].

The display returns to the **Channel** window.

The VOX function is enabled.

Note: The status of the VOX Gain Level is stored even if the transceiver is turned OFF.

■ Configuration using KPG-89D

- Configuring the VOX Gain Level (Refer to FPRG 6.7.4 Conventional tab - VOX Gain Level.)
- Assigning functions to the **PF** keys (Refer to FPRG 6.8 Key Assignment.)

28.1.2 VOX Delay Time

If the transceiver returns to the receive mode too quickly after a user stops speaking, his/ her final words may not be transmitted. To avoid this select an appropriate VOX delay time that allows all of words to be transmitted without an overly long delay after the user stops speaking.

The transceiver completes the VOX transmission when no voice is spoken into the microphone during the VOX Delay Time.

You can configure the VOX Delay Time using KPG-89D.



Figure 28-1 VOX Delay Time

■ Configuration using KPG-89D

- Configuring the VOX Delay Time (Refer to FPRG 6.7.4 Conventional tab - VOX Delay Time.)

28.1.3 TX Inhibit while Receiving

This function is used to restrict the VOX transmission while the transceiver is receiving signals.

You can configure the TX Inhibit while Receiving function using KPG-89D.

■ Configuration using KPG-89D

- Configuring the TX Inhibit while Receiving function (Refer to FPRG 6.7.4 Conventional tab - TX Inhibit while Receiving.)

28.1.4 Cancel Operation

This function allows the transceiver to disable the VOX function immediately when the **PTT** switch is pressed.

A user can enable the VOX function by pressing and holding the **PF VOX** key again for more than 2 seconds even if the function is disabled with the **PTT** switch. When the **PF VOX** key is not configured, the user can enable the VOX function again by turning the transceiver OFF, then turning it ON again.

You can configure the Cancel Operation using KPG-89D.

Table 28-1 Cancel Operation

Cancel Operation	Operation
Check (Enable)	The VOX function is disabled when the PTT switch is pressed.
Uncheck (Disable)	The VOX function will not be disabled even if the PTT switch is pressed.

■ Configuration using KPG-89D

- Configuring the Cancel Operation (Refer to FPRG 6.7.4 Conventional tab - Cancel Operation.)
- Assigning functions to the **PF** keys (Refer to FPRG 6.8 Key Assignment.)

28.1.5 VOX Proceed Tone

This function allows the transceiver to emit a tone notifying a user that the transmission using the VOX function has been enabled.

You can enable/ disable the VOX Proceed Tone using KPG-89D.

Table 28-2 VOX Proceed Tone Operation

VOX Proceed Tone	Operation
Check (Enable)	The transceiver emits the Proceed Tone when the VOX function is enabled.
Uncheck (Disable)	The transceiver does not emit the Proceed Tone even if the VOX function is enabled.

Note: The transceiver does not emit the Proceed when DTMF/ 2-tone/ FleetSync is used. If the Sidetone is configured to DTMF/ 2-tone/ FleetSync, the transceiver does not emit the VOX Proceed Tone.

■ Configuration **using** KPG-89D

- Configuring the VOX Proceed Tone (Refer to FPRG 6.7.4 Conventional tab - VOX Proceed Tone.)

29 VOICE SCRAMBLER

This function allows the transceiver to scramble the voice for private or secure communications.

There are 2 types of Scrambler function: Built-in and optional voice scrambler board.

The Transcript SC20-460 is one example of an optional scrambler board that may be plugged into the internal option board connector in the transceiver.

29.1 Configuring the Voice Scrambler

You can configure the following functions that are relevant to Voice Scrambler using KPG-89D.

- Scrambler
- Scrambler Status Memory (Scrambler)
- SC20-460 Scrambler
- Scrambler Status Memory (SC20-460 Scrambler)

29.1.1 Scrambler

This option enables the internal Scrambler in the AQUA IC. You can use this programmed scrambler function to allow you to scramble the transmitted voice.

This function is enabled when the Scrambler checkbox in the **Channel Edit** window or the **GID Edit** window is checked.

You can enable/disable the Scrambler function using KPG-89D.

Note: You cannot use the simple Scrambler when "Voice Scrambler" is selected in Optional Board menu.

■ Transceiver Operation

● Enabling the Scrambler function

1. Press the **PF Scrambler** key.

The "◇" icon appears and the Scrambler function is enabled.



TK-2180/ 3180



TK-7180/ 8180

● Disabling the Scrambler function

1. Press the **PF Scrambler** key.

The "◇" icon disappears and the Scrambler function is disabled.

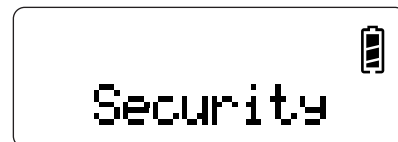

TK-2180/ 3180



TK-7180/ 8180

■ Configuration using KPG-89D

- Configuring the Scrambler function (Refer to FPRG 6.3.17 Scrambler and FPRG 6.6.16 Scrambler.)
- Assigning functions to the **PF** keys (Refer to FPRG 6.8 Key Assignment.)

29.1.2 Scrambler Status Memory (Scrambler)

This function allows the transceiver to store the Scrambler status.

You can enable/disable the Scrambler Status Memory using KPG-89D.

■ Configuration using KPG-89D

- Configuring the Scrambler Status Memory (Refer to FPRG 6.7.1 Common-Page 1 tab - Scrambler Status Memory.)

29.1.3 SC20-460 Scrambler

You can install the SC20-460 Scrambler in the transceiver if a higher security level is required.

You can configure the SC20-460 Scrambler by selecting the “Voice Scrambler” in **Extended Function > Optional Board**.

You can configure the SC20-460 Scrambler using KPG-89D.

■ Transceiver operation

● Enabling the SC20-460 Scrambler

1. Press the **PF Scrambler** key.

The “◇” icon appears and the SC20-460 Scrambler function is enabled.



TK-2180/ 3180



TK-7180/ 8180

● Changing the Scrambler code

1. Press and hold the **PF Scrambler** key for more than 1 second.

The current Scrambler code appears on the display.



TK-2180/ 3180



TK-7180/ 8180

2. Change the Scrambler Code using **[B]/ [C], Selector**, or **[^]/ [v]**.



TK-2180/ 3180



TK-7180/ 8180

3. Press **[Side 1]/ [▲]**.

The configuration is enabled.



TK-2180/ 3180



TK-7180/ 8180

● Disabling the SC20-460 Scrambler function

1. Press the **PF Scrambler** key.

The “◇” icon disappears and the SC20-460 Scrambler is disabled.



TK-2180/ 3180



TK-7180/ 8180

■ Configuration using KPG-89D

- Configuring the Optional Board (Refer to FPRG 6.15.1 Extended Function - Optional Board and FPRG 6.15.2 Optional Board tab - Optional Board.)
- Configuring the Scrambler code (Refer to FPRG 6.3.18 Scrambler Code and FPRG 6.6.17 Scrambler Code.)
- Assigning functions to the **PF** keys (Refer to FPRG 6.8 Key Assignment.)

29.1.4 Scrambler Status Memory (SC20-460 Scrambler)

This function allows the transceiver to store the SC20-460 Scrambler status and the Scrambler code.

When the Scrambler Status Memory function enabled, the Scrambler On/ Off configuration is also read when reading data from the transceiver.

You can enable/ disable the Scrambler Status Memory using KPG-89D.

■ Configuration using KPG-89D

- Configuring the Scrambler Status Memory (Refer to FPRG 6.7.1 Common-Page 1 tab - Scrambler Status Memory.)

The transceiver is equipped with an internal clock IC. With the IC, the current time can be displayed on the LCD.

The Clock Function has the following four functions.

- Displaying the current time
- Displaying the time when the transceiver is turned ON
- Time Stamp function for FleetSync Messages
- Time adjustment

30.1 Current Time Display

This function allows the transceiver to display the current time on the main display.

■ Transceiver Operation

1. Press the PF Clock key.

The current time appears on the main display.

- 24-hour format

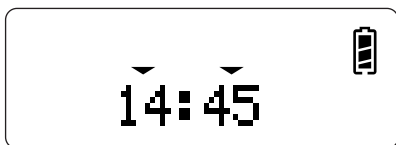

TK-2180/ 3180

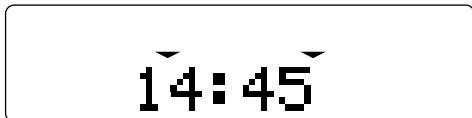

TK-7180/ 8180

- 12-hour format

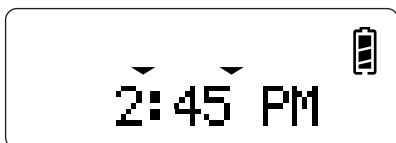

TK-2180/ 3180

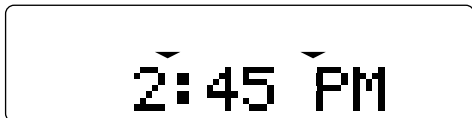

TK-7180/ 8180

2. Press any key.

The display returns to the previous display.

Note: The transceiver is equipped with a separate battery for the clock IC. When this battery runs out, the clock will not be displayed properly. In this case, you must recharge the battery and configure the time again. In this case, "- : -" appears.

■ Configuration using KPG-89D

- Assigning functions to the PF keys (Refer to 6.8 Key Assignment.)

30.2 Displaying the Time when the Transceiver is Turned ON.

This function allows the transceiver to display the current time when the transceiver is turned ON. The transceiver displays the time when it is turned ON for 2 seconds, then it displays the channel number. When "Clock" is selected in the Power-on Message type, the time appears when the transceiver is turned ON.

You can enable/disable the Power-on Clock function using KPG-89D.

Note:

- ◆ You cannot use this function with the Power-on text function.
- ◆ The Power-on Clock does not appear when the Transceiver Password is configured.

■ Configuration using KPG-89D

- Configuring the Power-on Clock (Refer to 6.7.2 Common-Page 2 tab - Message Type.)

30.3 Configuring the Time

This function allows you to configure the time.

You can configure the time when the Optional Features -) Common Page 2 -) Clock Adjustment checkbox is checked.

You can enable/disable the time configuration using KPG-89D.

■ Transceiver operation

1. Press and hold [C], then press the Power switch at the same time.

The transceiver enters Year Entry Mode.

2. Select the year and press [S].

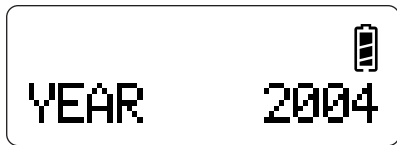

TK-2180/ 3180



TK-7180/ 8180

3. Select the month and press [S].



TK-2180/ 3180



TK-7180/ 8180

4. Select the date and press [S].



TK-2180/ 3180

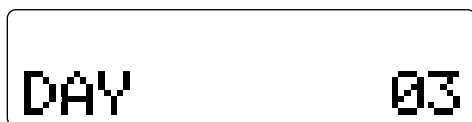

TK-7180/ 8180

5. Select the hour and press [S].

You can configure the time in 24 hours.



TK-2180/ 3180



TK-7180/ 8180

6. Turn the transceiver OFF after you complete configuring the minute.

The time is now adjusted.



TK-2180/ 3180



TK-7180/ 8180

Note:

- ◆ The Key-entry Error tone sounds if you press [S] when the entered value is invalid. In this case, the transceiver does not move to the next item.
- ◆ The transceiver returns to Year Entry Mode when you press the [S] after configuring the minute.

■ **Configuration using KPG-89D**

- Configuring the Clock Adjustment function (Refer to 6.7.2 Common-Page 2 tab - Clock Adjustment.)

30.4 Adjustment Time

This function allows a user to adjust the time at the same time when writing data to the transceiver using KPG-89D.

This function is enabled when the Adjustment Time checkbox of the Write Data in the Transceiver window is checked.

You can enable/ disable the Adjustment Time using KPG-89D.

■ **Configuration using KPG-89D**

- Configuring the Adjustment Time (Refer to 7.2.1 Adjustment Time.)

This function allows a user to record and playback recorded voice. It can be used for the Voice Guide function and the GPS data storage function at the same time.

31.1 Auto Recording

This function allows a user to automatically record the transmitted or received voice.

The user can record the following types of audio signals.

- Audio signal on the input line of the microphone while the **PTT** switch is pressed.
- Transmitted voice in the Emergency Mode
- Received voice

The user can record the transmitted voice using the **PTT** switch or in the Emergency Mode. The transceiver does not record the transmitted voice with the Ext. PTT, Transpond, or data transmission.

The user can playback and listen to the stored voice data using the Message Playback function. (Refer to 31.4 Message Playback.)

You can configure the Auto Recording duration to 30 seconds or disable the function. You cannot configure this function when “Disable” is selected.

Note:

- ◆ A maximum recording time is 300 seconds (Auto Recording/ Voice Memo/ Auto Reply Message).
- ◆ The Auto Recording function is disabled when Voice Memo Mode/ Auto Reply Message Mode/ Message Playback Mode is enabled.
- ◆ When the GPS Data Storage function is enabled, the transceiver may not record all incoming signals.

■ Transceiver Operation

1. The dot on the left appears while the Auto Recording function is enabled.



TK-2180/ 3180



TK-7180/ 8180

■ Configuration using KPG-89D

- Configuring the Auto Recording function (Refer to FPRG 6.7.6 VGS-1 tab - Auto Recording.)

31.2 Voice Memo (Manual Recording)

This function allows a user to manually record the transmitted voice or received signal.

The user can record the following types of audio signals.

- Voice spoken into the microphone
- Voice transmitted by pressing the **PTT** switch
- Voice transmitted in the Emergency Mode
- Received voice

When the recording is completed, the voice data is automatically stored in the VGS-1. The user can listen to the stored voice data using the Message Playback function. (Refer to 31.4 Message Playback.)

You can enable/disable the Voice Memo, and/or configure the maximum recording time and the storage function options using KPG-89D.

Although you must configure the Voice Memo in steps of 30 seconds, the transceiver records each data in steps of 15 seconds.

For example, when the Voice Memo is configured for 60 seconds, the user can record a maximum of 4 voice memos (15 seconds x 4 times).

Table 31-1 Voice Memo Configuration

Function	Configuration	Operation
Voice Memo	Disable/ 30 - 300	You can configure the VGS-1 recording channel that is used to record the Voice Memo in steps of 30 seconds. A user cannot use the Voice Memo function when “Disable” is selected. You can configure the recording channel with a maximum of 300 seconds.
Stores the latest received messages	Check (Enable)	The message recorded in the new recording channel is overwritten over the old message. The message recorded in the old channel is deleted.
	Uncheck (Disable)	When messages are stored to all recording channels, the transceiver will not record a new message.

Note:

- ◆ A The maximum recording time is 300 seconds (Auto Recording/ Voice Memo/ Auto Reply Message).
- ◆ When the GPS Data Storage function is enabled, the transceiver may not be able to record all incoming signals.

■ Transceiver Operation

● Recording Voice

1. Press and hold the **PF Playback** key for more than 1 second.

The transceiver enters the Voice Memo Mode and recording starts.

The "REC" icon appears on the sub display and the start time of recording and the remaining time for recording on the main LCD.

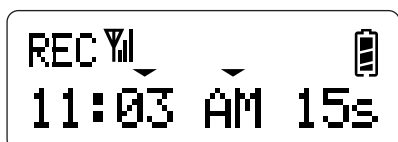

TK-2180/ 3180



TK-7180/ 8180

2. Press **[S]** or **[#]**.

The transceiver stops recording. The transceiver also stops recording when the recording time expires.

The transceiver writes voice data to the flash memory.



TK-2180/ 3180



TK-7180/ 8180

■ Configuration using KPG-89D

- Configuring the Manual Recording function (Refer to FPRG 6.7.6 VGS-1 tab - Manual Recording.)
- Assigning functions to the **PF** keys (Refer to FPRG 6.8 Key Assignment.)

31.3 Auto Reply Message

This function allows a user to record the voice message even if he/she is away from the transceiver.

You can enable this function by using the FleetSync Individual Call.

When the recording is completed, the voice data is automatically stored in the flash memory in the VGS-1. The user can playback and listen to the stored voice data using the Message Playback function.

You can configure the recording channel of the Auto Reply Message in steps of 30 seconds using KPG-89D. The user cannot use this function when "Disable" is selected.

Although you must configure the Auto Reply Message in steps of 30 seconds, the transceiver records in steps of 15 seconds.

When the Auto Reply Message is configured to 60 seconds, the user can record a maximum of 4 voice memos (15 seconds x 4 times).

Note:

- ◆ A The maximum recording time is 300 seconds (Auto Recording/ Voice Memo/ Auto Reply Message).
- ◆ The Auto Recording function is disabled when Voice Memo Mode or Message Playback Mode is enabled.

■ Transceiver Operation

● Entering in Auto Reply Message Mode

1. Press the **PF Auto Reply Message** key.

The transceiver enters Auto Reply Message Mode.

The dot appears on the left side of the triangle icon.

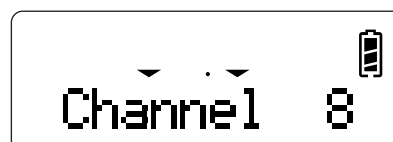

TK-2180/ 3180



TK-7180/ 8180

● Terminating Auto Reply Message Mode

1. Press the **PF Auto Reply Message** key.

The transceiver terminates Auto Reply Message Mode and the dot disappears.

■ Configuration using KPG-89D

- Configuring the Auto Reply Message function (Refer to FPRG 6.7.6 VGS-1 tab - Auto Reply Message.)
- Assigning functions to the PF keys (Refer to FPRG 6.8 Key Assignment.)

31.4 Message Playback

This function allows the transceiver to playback the received or transmitted voice that has been recorded in Recording, Voice Memo Mode, and Auto Reply Message Mode. A user can also delete unnecessary recorded data.

If the last recorded message is stored using the Auto Recording function, the transceiver plays back this message first. Other than this situation, the transceiver plays back the data stored in the flash memory in the VGS-1.

The transceiver plays voice data in the following order.

- Auto Recording buffer
- Auto Recording channel
- Voice Memo Recording channel
- Auto Reply Message Recording channel (Return to the top.)

Note:

- ◆ The transceiver enters receiving mode when receiving a call while playing back voice data.
- ◆ The transceiver enters transmitting mode when a user makes a call while playing voice data.
- ◆ The Message Playback function is automatically disabled when the GPS Data Storage function is enabled.

■ Transceiver Operation

● Playing back Voice data.

1. Press the PF Playback key.

The transceiver plays back the recorded voice. The configured characters appear on the main display while playing back the recorded voice.

- **Playing Auto Recording buffer**
“STORE?” appears on the display.



TK-2180/ 3180



TK-7180/ 8180

● Playing back the recorded voice on the Auto Recording Channel

The recording type, time, and date appear on the display.

“AR 2:45 PM▶” appears when the message is recorded at 14:45 on May 16th.



TK-2180/ 3180

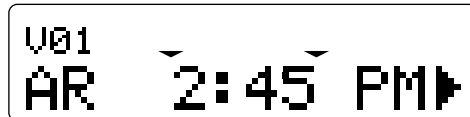

TK-7180/ 8180

● Playing back the recorded voice on the Voice Memo Recording Channel.

The recording type, time and date appear on the display.

“VM 2:45 PM▶” appears when the message is recorded at 14:45 on May 16th.

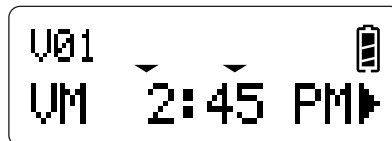

TK-2180/ 3180

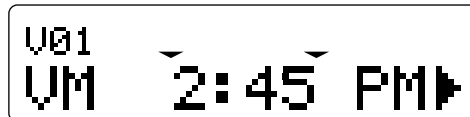

TK-7180/ 8180

● Playing back the recorded voice on the Auto Reply Message Recording Channel .

The recording type, time, date and the caller's ID appear on the display.

“RM 2:45 PM” appears, and then subsequently “05/16 User Name” appears when the message is recorded at 14:45 on May 16th.

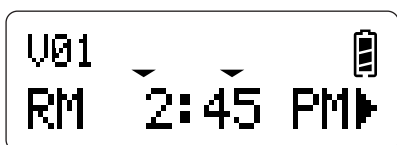

TK-2180/ 3180

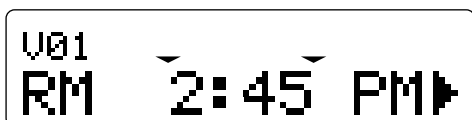

TK-7180/ 8180

- **Complete playing back the recorded message**

When the message recorded in the last recording channel is played, the “END OF MSG” icon appears for 2 seconds. The transceiver terminates the Message Playback Mode.

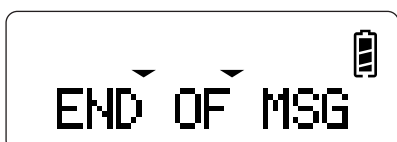

TK-2180/ 3180



TK-7180/ 8180

- **When no Voice Message is recorded**
“EMPTY” appears on the display.



TK-2180/ 3180



TK-7180/ 8180

- **Selecting the Recording Channel**

1. Select the recording channel to playback using **Selector**, the **PF Zone Up** and **PF Zone Down** key while the recorded channel is played back. You can change the recording .

- **Deleting the Recording Channel**

1. Select the recording channel to delete using **Selector**, the **PF Zone Up** and **PF Zone Down** key.



TK-2180/ 3180



TK-7180/ 8180

2. Press **[A]** or **[#]**.

The “Voice Message Number” appears on the sub display and “DELETE?” appears on the main display.

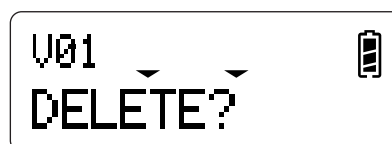

TK-2180/ 3180



TK-7180/ 8180

3. Press **[S]** or **[*]**.

The selected channel is deleted and the transceiver starts playing the next recording channel.

- **Deleting all recording channels**

1. Press and hold **[A]** or **[#]** while the recording channel appears.

“ALL” appears on the sub display and “DELETE?” appears on the main display.

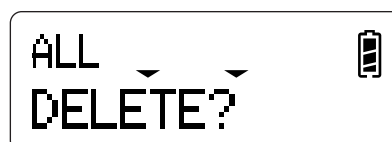

TK-2180/ 3180



TK-7180/ 8180

2. Press **[S]** or **[*]**.

All messages are deleted and EMPTY appears on the display.

● **Storing the Recorded Voice Data in the flash memory of the VGS-1**

1. Confirm that the transceiver can play the Auto Recording buffer.

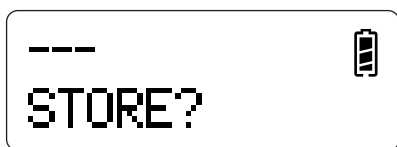

TK-2180/ 3180

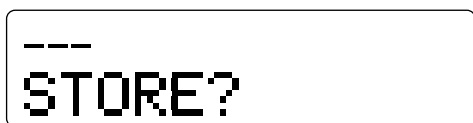

TK-7180/ 8180

2. Press **[Side 2]** / **[■]**.

“WRITING” appears on the main display and the voice data is stored in the flash memory.

■ **Configuration using KPG-89D**

- Assigning functions to the **PF** keys (Refer to FPRG 6.8 Key Assignment.)

31.5 Voice Guide

This function allows you to announce the key function when the **PF** key is pressed.

You can configure the Voice Guide using KPG-89D.

■ **Zone-CH/GID Guide**

The transceiver emits the following voice guide when the Zone-CH/GID Guide function is enabled.

Table 31-2 Voice Type of the Zone-CH/GID Guide

Key Function	Selected Zone-CH/GID	Voice Type
CH/GID Down CH/GID Up CH/GID Up/Down	1	One
	2	Two

	20	Twenty
	21	Twenty-one

	100	One-hundred
	101	One zero one

	249	Two forty-one
250	Two fifty	
Zone Down Zone Up Zone Up/Down	1	Zone One
	2	Zone Two

	20	Zone Twenty
	21	Zone Twenty-one

	100	Zone One-hundred
	101	Zone One zero one

	127	Zone One twenty-seven
128	Zone One twenty-eight	

Note: The CH/GID Guide is announced when the Zone Guide is selected.

■ **Function Guide**

The transceiver emits the following voice guide when the Function Guide is enabled.

Table 31-3 Voice Type of the Function Guide

Key Function	Voice Message	
	Key Function On	Key Function Off
Clock	Reading the clock	-
Home CH/GID	Home CH/GID	Zone-CH/GID Number
Horn Alert	Horn Alert On	Horn Alert Off
Key Lock	Key Locked	Key Unlocked
Low Transmission Power	RF Low Power On	RF Low Power Off
Public Address	Public Address On	Public Address Off
Scrambler	Scrambler On	Scrambler Off
Scan	Scan On	Scan Off
Send the GPS Data	Send GPS	-
Speaker Attenuation	Speaker Attenuation On	Speaker Attenuation Off
Talk Around	Talk Around On	Talk Around Off
VOX	VOX On	VOX Off

The transceiver activates the Voice Guide function in the following status and emits the following announce.

Table 31-4 Status of the Transceiver and Voice Type

Category	Status	Voice Type
Transceiver Password	Operating the transceiver while the Transceiver Password function is enabled.	Radio Locked
Key Lock	Operating the transceiver while the Key Lock function is enabled.	Key Locked
Message Playback	Selecting the Message	“Clock” - “Message Type” Example: “ten-thirty AM Voice memo” “twelve-eleven PM Reply Message”
FleetSync	Selecting the SelCall List using the Selector or [Up] / [Down] .	ID List “Number” Example: “ID List fourty-three”
	Selecting the Status List using the Selector or [Up] / [Down] .	Status List Number Example: Status List sixty-eight
	The Status Message is not properly sent to the receiving party.	Message denied

Note: The Key Beep A/ B does not sound when the Voice Guide is enabled.

■ Configuration using KPG-89D

- Configuring the Zone-CH/GID Guide (Refer to FPRG 6.7.6 VGS-1 tab - Zone-CH/GID Guide.)
- Configuring the Function Guide (Refer to FPRG 6.7.6 VGS-1 tab - Function Guide.)

31.6 GPS Data Storage

(TK-7180/ 8180 only)

This function allows the transceiver to store the FleetSync GPS data in the VGS-1. The transceiver can store the FleetSync GPS data in the VGS-1 for each Data Storage Cycle.

The transceiver can store a maximum of approximately 10000 GPS data (10752 Messages).

You can transmit the GPS data to another station or read it with a PC.

31.6.1 GPS Data Storage

(TK-7180/ 8180 only)

The GPS data is written to the VGS-1 at the cycle configured in the Data Storage Cycle.

You can configure the GPS Data Storage and the Data Storage Cycle using KPG-89D.

Note:

- ◆ The GPS data is written to the VGS-1 when the transceiver receives valid data from the GPS Unit.
- ◆ The GPS data is not stored when one or more of Recording Mode, Voice Memo Mode, Auto Reply Message, and Message Playback is enabled.

■ Configuration using KPG-89D

- Configuring the GPS Data Storage (Refer to FPRG 6.7.6 VGS-1 tab - GPS Data Storage.)
- Configuring the Data Storage Cycle (Refer to FPRG 6.7.6 VGS-1 tab - Data Storage Cycle.)

31.6.2 Reading from GPS Data Storage

You can read the GPS Data Storage with the following methods.

■ Reading GPS Data using the Air Function

The transceiver requests the data to the base station using the FleetSync protocol. The mobile transceiver equipped with the VGS-1 sends the GPS data stored in the VGS-1 when receiving the reception request.

Note:

- ◆ The mobile transceiver must send the data written in the VGS-1.
- ◆ The mobile station does not send data to the base station even if it receives the latest data from the GPS Unit while transmitting. The transceiver sends data upon receiving the GPS data.

■ Reading GPS Data Using a PC

The transceiver (normally base station) can request the mobile transceivers to send the stored GPS data using the FleetSync PC protocol. To use this function, connect the transceiver equipped with the VGS-1 to a PC. The mobile transceiver sends the GPS data stored in the VGS-1 when receiving the transmission request from another transceiver.

Note:

- ◆ The GPS data request must be managed by the PC software application.
- ◆ The mobile transceiver must send the data written to the VGS-1.
- ◆ The mobile transceiver does not send data to the PC even if it receives the latest data from the GPS unit while transmitting. The transceiver sends data upon receiving the GPS data.

Symbols

* and # Digit Time..... 83

Numerics

2-tone 89

A

A Tone/ B Tone/ C Tone/ D Tone 92
 AC Control 134
 ACK Delay Time..... 121
 Adjusting the Volume 12
 Adjustment Time 157
 Alert Tone (Emergency Response)..... 123
 Alert Tone (Individual Call)..... 123
 Alert Tone (Other Selective Calls)..... 123
 Alert Tone (Paging Call)..... 123
 Alert Tone (Status/Short Message Call)..... 123
 Alert Tone Pattern 27
 Antenna..... 1
 fcArea Code 63
 ARQ Mode 67
 Assigning Functions to Auxiliary Output Ports 147
 Assigning Functions to the Auxiliary Input Ports 144
 Assigning Functions to the PF Keys 41
 Audio Control 53, 59
 Auto Recording 158
 Auto Reply Message 41, 159
 Auto Reset Timer 85, 92, 120
 Auto Telephone..... 41, 84
 Auto Telephone Search 59, 64
 Autodial 41, 86
 Autodial List 86
 Autodial List Selection..... 80
 Autodial Programming..... 41, 86
 Automatic Scan 125
 AUX A 41, 148
 AUX B 41, 148
 AUX In Status Message 1 - 3..... 147
 AUX Input Status Message 105
 AUX key 1
 AUX Out Status Message 1 - 3..... 148
 AUX Output Status Message 106

B

Background Transmission..... 139
 Backlight (TK-2180/ 3180 only)..... 18

Base Fleet/ID 112
 BASIC FUNCTION..... 1
 Battery Saver (TK-2180/ 3180 only) 9
 Battery Status/Warning (TK-2180/ 3180 only) 20
 BCL Override 46, 53
 Beat Shift 7, 55
 Beginning of Transmit 49
 Broadcast Cal 198
 Busy Channel Lockout 46, 55
 BUSY LED 18

C

Call Indicator 61
 Call Key..... 8
 Caller ID Display 94
 Caller ID Stack 118
 CH/GID Recall 41, 134
 CH/GID Select A-D 146
 Changing the CH/GID 13
 Changing the Zone 12
 Channel Busy..... 148
 Channel Entry 13, 41
 Channel Name 22, 54
 Channel Spacing..... 5
 Clear to Talk..... 66
 Clear to Transpond 51, 86, 92
 Clock 41, 156
 COM 0 (Mic Jack) 34
 COM 1 (DB-25) 34
 COM 2 (DB-25) 34
 COM port 143
 Communication Port 34
 Comander 6, 55, 62
 Conditions to Activate Scan 125
 Conditions to Resume Scan 125
 Configuring Emergency Mode 136
 Configuring Horn Alert 38
 Configuring Scan 130
 Configuring the FleetSync..... 118
 Configuring the Time..... 156
 Configuring the Voice Scrambler 153
 Configuring the VOX Function 150
 Connect ID (BOT) 81
 Connecting to the Phone Line..... 64
 Control Tone 24
 Conventional Group 16, 17, 37, 47, 52, 69
 COR 148
 COR or Channel Busy 148
 Current Time Display 156

D

D Code Assignment 83
 Data 55, 62, 142

Data CH/GID Dwell Time	142, 147
Data Communication.....	142
Data Communication Configuration	142
Data Delay Time	58
Data Override (TK-7180/ 8180 only).....	143
Data PTT.....	144
Data Transmission with QT/DQT	142
Data Transmit Modulation Delay Time.....	122
Data Zone-CH/GID.....	52, 58, 142
Decode ID (Block IDs).....	60
Decoder 1 - 4	91
Direct CH/GID	15
Direct OST	74
Disconnect ID (EOT).....	81
DISPLAY	18
Display Character.....	22, 42
Display Off	147
Displaying the Time when the Transceiver is Turned ON.	156
Dropout Delay Time	133
DTC.....	146
DTMF	77
DTMF Hold Time.....	83
DTMF Speed.....	82
Duration of 1st Tone	90
Duration of 2nd Tone	90
Duration of Single Tone	90
Dwell Time	133

E

Embedded Message	33
Embedded Message with Password	33
Emergency.....	42, 105, 147
Emergency Call Fleet.....	141
Emergency Call ID	141
Emergency CH/GID Type	137
Emergency Cycle	137
Emergency Display	138
Emergency DTMF ID	140
Emergency ID	140
Emergency Key Delay Time.....	139
Emergency LED	139
Emergency Mic Sense	139
Emergency Mode.....	136
Emergency Mode Type.....	138
Emergency Text.....	138
Emergency Zone-CH/GID	137
Encode.....	82, 89
Encode Data Type	59
Encode/ Decode ID.....	61
End of Transmit.....	49
External Hook	147
External Monitor	146
External PTT (Data)	145
External PTT (Voice).....	145

F

First Digit Delay Time.....	82
First Digit Time	83
First Tone Delay Time.....	90
Fix ID.....	60
Fleet Call.....	98
FleetSync	94
FleetSync Baud Rate	119
FleetSync II	120
Free System Ringback.....	65
Functions and Panel Layout	1

G

Gap Time	90
GID Name	22, 61
GPS Combination	112
GPS Data Storage	115, 163
GPS Data Storage (TK-7180/ 8180 only)	163
GPS Function (TK-7180/ 8180 only).....	111
GPS Message Type.....	114
GPS Report Interval Time (Ignition On).....	114
GPS Report Mode.....	113
GPS Report on Data Zone-CH/GID	114
GPS Time Mark	114
Group ID	61, 120
Group Scan.....	130
GTC Count.....	121

H

Home CH/GID.....	14, 42
Home Channel	52
Home Channel Operator Selectable	52
Home GID	58
Home GID Operator Selectable	58
Home Repeater.....	63
Horn Alert (TK-7180/ 8180 only).....	37, 62
Horn Alert Logic Signal	38
Horn Alert Mode.....	40
Horn Alert Operation During FleetSync Call	38
Horn Alert Operation using Option Signaling (DTMF, 2-Tone) and LTR ID (GID, FIX ID).....	37

I

Icons	19
ID List.....	99
ID/Message Stack with Time Stamp	118
Ignition Sense (TK-7180/ 8180 only)	36
Individual Call/ Group Call	97
Interfleet Call.....	119

J

Jumping to the Specified Zone-CH/GID using the
External Device Connected to the Transceiver..... 149

K

Key Assignment 41
Key Lock (TK-2180/ 3180 only)..... 7
Keypad 1
Keypad Auto PTT..... 79
Keypad Operation 7

L

LCD Brightness (TK-7180/ 8180 only) 19
LCD Display 1, 18
List Scan 128
Locator Tone 25, 139
Locator Tone 1 Duration 137
Locator Tone 2 Duration 138
LOK 147
Long Message Function..... 110
Long Message On Data Zone-CH/GID 111
Lookback..... 133
LTR Trunking 57

M

Main Display..... 21
Making a Selective Call..... 95
Man Down Delay Time (TK-2180/ 3180 only) 139
Man Down Logic Type (TK-2180/ 3180 only)..... 140
Man Down Pre-alert (TK-2180/ 3180 only) 140
Man Down Switch Type (TK-2180/ 3180 only)..... 139
Manual Dialing 77, 83, 120
Manual Scan 125
Manually Changing the Zone-CH/GID during Scan 126
Maximum ACK Wait Time 121
Maximum Volume (TK-2180/ 3180 only)..... 26
Message Display Type..... 122
Message Memory..... 118
Message Playback..... 160
Mic Mute 146
Mic PTT (TK-7180/ 8180 only)..... 9
Mic Sense 147
Mic Sense Control..... 8
Microphone 1
Microphone connector..... 2
Minimum Volume 25
Monitor 42, 70
Multi Scan 128

N

Number of Retries 121
Number of Times 113

O

Off-hook Decode (TK-7180/ 8180 only) 70
Off-hook Horn Alert 39
Off-hook Scan (TK-7180/ 8180 only) 134
Operations during Scan in
Conventional Group 71, 73, 126
Operations during Scan in Trunking system 73
Operations when Manually Changing the
Zone-CH/GID while Scan Pauses to Receive..... 126
Operations when Scan cannot be Resumed 125
Operations while Making Scan in Trunking System.... 127
Optional Signaling..... 55, 61, 68
Optional Signaling Decode Condition 52
OST 42, 74
OST Status Memory 74
OST Table..... 76
Overwrite Password..... 32
Own Fleet/ID 119

P

Password Function 30
PC Interface Protocol..... 124
PF keys 1, 2
Power Switch 1
Power Switch Status Memory (TK-7180/ 8180 only) 9
Power Switch/Volume Control 1
Power-off Status Message..... 106
Power-on Scan 135
Power-on Status Message..... 106
Power-on Text..... 23
Power-on Tone 24
Priority 1 Temporary Delete/Add..... 134
Priority 1/ Priority 1 Zone-CH 131
Priority 2 Temporary Delete/Add..... 134
Priority 2/ Priority 2 Zone-CH 132
Priority Channel Stop Tone 135
Priority Scan..... 129
Proceed Tone Delay Time 28
PTT ID..... 49, 55, 61
PTT ID (CH/GID Information)..... 49
PTT ID Function..... 94
PTT ID Sidetone 94
PTT ID Type..... 49
PTT Out 148
PTT Proceed Tone..... 28
PTT Release Tone 27
PTT switch 1
Public Address (TK-7180/ 8180 only) 29

Q

QT/DQT Decode	54
QT/DQT Decode/Encode	68
QT/DQT Encode	54

R

Random Access (Contention)	122
Read Authorization Password	31
Reading from GPS Data Storage	163
Receive	16
Receive Duration	138
Receive Frequency	54
Receiving a Selective Call	97
Receiving the Long Message	110
Receiving the Short Message	108
Receiving the Status Message	103
Redial	80
REMOTE CH/GID LIST (TK-7180/ 8180 only)	149
Repeater Information Table	63
Reserved Status of the Status Message	104
Restricted ID in TA	50
Revert CH/GID	132
Revert CH/GID Display	134

S

SC20-460 Scrambler	154
Scan	42, 125
Scan Add	55, 62
Scan Del/Add	130
Scan List	53, 59, 131
Scan List Table	131
Scan Type	133
Scan Weight	57
Scrambler	42, 62, 153
Scrambler Code	56, 63
Scrambler Status Memory (SC20-460 Scrambler)	155
Scrambler Status Memory (Scrambler	153
Selectable Tone Level	27
Selective Call Alert LED	86, 92, 122
Selective Call Function	95
Selector	1
Sending the Long Message	110
Sending the Short Message	107
Sending the Status Message	99
Short Message on Data Zone-CH/GID	109
Short Message Serial Output	109
Short Message Stack	109
Side 1 key	1
Side 2 key	1
Sidetone	25, 83, 90
Signal Strength Indicator	20

Signaling	68
Signaling (Audio Control)	69
Signaling (Decode)	69
Single Scan	127
Sound	24
Speaker	1
Speaker Attenuation (TK-2180/ 3180 only)	28
Speaker Mute	146
Squelch	71
Squelch Level	5, 42
Stack	115
Standard QT	76
Status List	106
Status Message Function	99
Status Message on Data Zone-CH/GID	105
Status Message Serial Output	105
Status Message Stack	105
Store & Send	77, 84
Stores the Latest Received Messages	117
Stun	85
Sub Display	21
Supervisor Call	98
Switching the Horn Alert ON/OFF	37
System Busy	148
System Search	65
System Search for Data Channels	66
System Search for Voice Channels	66

T

TA Busy Channel Lockout	48, 59
TA Key	48, 59
Talk Around	42, 47, 62
Target Fleet/ID (Status Message)	106
Telephone (Block IDs)	60
Telephone Interconnect	64
Timed Power-off	36
Time-out Timer (Dispatch)	45, 58
Time-out Timer (Telephone)	45, 58
Time-out Timer (TOT)	44, 53
Timer Function	118
Tone Off	74
Tone Pattern	24
Tone Volume	26
Tone Volume Offset	26
TOR	148
TOR or Channel Busy	148
TOT Pre-alert	44, 53
TOT Rekey Time	44, 53
TOT Reset Time	44, 53
Transceiver Operation When Using the ARQ Function in the External Modem	67
Transceiver Operation When Using the ARQ Function with FleetSync	67
Transceiver Password	30
Transmit	17

Transmit Delay Time (Receive Capture).....	121	Zone Add	53, 59
Transmit Duration.....	137	Zone Description	4
Transmit Frequency	54	Zone Name	22, 52, 57
Transmit Output Power	4	Zone Name Text Length	22
Transmit Power	54, 61		
Transmit/Receive Frequency	4		
Transmitting a 2-tone	89		
Transmitting DTMF Tone	77		
Transmitting with Talk Around.....	17		
Transpond.....	51, 62		
Transpond Delay Time	51		
Transpond Using the LTR ID	51		
Transpond Using the Optional Signaling.....	51		
Transpond/ Alert Tone	84, 91		
Turning the Transceiver ON/OFF.....	11		
Turning the Transceiver ON/OFF with the Ignition Sense Function	36		
Turning the Transceiver ON/OFF with the Ignition Sense Function and the Power Switch.....	36		
TX Inhibit (Block IDs)	60		
TX Inhibit while Receiving	151		
TX LED	18		
TX LED/BUSY LED.....	1		
TXS	148		

U

Unit ID Encode Block	119
Unit ID Serial Output	122
[Up]/[Down] key.....	1
Using Function Keys	12
Using the Ignition Sense Terminal	36

V

VGS	158
Voice Guide	162
Voice Memo (Manual Recording).....	158
Voice Scrambler.....	56, 153
Volume Indicator (TK-7180/ 8180 only)	23
VOX (TK-2180/ 3180 only).....	150
VOX Delay Time	151
VOX Gain Level	150
VOX Proceed Tone	151

W

Warning Tone	25
Wide/Narrow	55, 58

Z

Zone	52, 57
------------	--------

