

## CONTENTS

<b>GENERAL</b> .....	<b>2</b>	<b>SCHEMATIC DIAGRAM</b>	
<b>PARTS LIST</b> .....	<b>3</b>	TK-760G(K,K2)/760HG(K2)	
<b>PC BOARD</b>		DISPLAY UNIT (X54-3270-10) .....	<b>32</b>
DISPLAY UNIT (X54-3270-10) .....	<b>12</b>	TX-RX UNIT (X57-5950-10/12/16).....	<b>32</b>
VCO UNIT (X58-4670-XX) .....	<b>13</b>	VCO UNIT (X58-4670-XX) .....	<b>34</b>
TK-760G(K,K2)/760HG(K2)		TK-760G(M)/760HG(K,M)	
TX-RX UNIT (X57-5950-10/12/16).....	<b>14</b>	DISPLAY UNIT (X54-3270-10) .....	<b>36</b>
TK-760HG(K,M)		TX-RX UNIT (X57-5950-14/21).....	<b>36</b>
TX-RX UNIT (X57-5950-14).....	<b>20</b>	VCO UNIT (X58-4670-10).....	<b>38</b>
TK-760G(M)			
TX-RX UNIT (X57-5950-21).....	<b>26</b>		

# TK-760G/760HG

## Document Copyrights

Copyright 2011 by Kenwood Corporation. All rights reserved.

No part of this manual may be reproduced, translated, distributed, or transmitted in any form or by any means, electronic, mechanical, photocopying, recording, or otherwise, for any purpose without the prior written permission of Kenwood.

## Disclaimer

While every precaution has been taken in the preparation of this manual, Kenwood assumes no responsibility for errors or omissions. Neither is any liability assumed for damages resulting from the use of the information contained herein. Kenwood reserves the right to make changes to any products herein at any time for improvement purposes.

## GENERAL

### SERVICE MANUAL LIST

Title	Part No.	Frequency range (MHz)	DISPLAY UNIT (PCB No.)	TX-RX UNIT (PCB No.)	VCO UNIT (PCB No.)
TK-760G/762G	B51-8497-00	148-174: K 146-174: M	X54-3270-10: TK-760G (J72-0683-02)	X57-5950-10: TK-760G (J72-0677-02)	X58-4670-10 (J72-0676-02)
TK-760G/762G REVISED	B51-8497-10	148-174: K 136-162: K2 146-174: M	X54-3270-10: TK-760G (J72-0683-02)	X57-5950-XX (J72-0677-02)	X58-4670-10/11 (J72-0676-02)
TK-760HG/762HG SUPPLEMENT	B51-8538-00	148-174: K 146-174: M	X54-3270-10: TK-760HG (J72-0683-02)	X57-5950-14: TK-760HG (J72-0759-02)	X58-4670-10 (J72-0676-02)
TK-760HG/762HG REVISED	B51-8538-10	148-174: K 136-162: K2 146-174: M	X54-3270-10: TK-760HG (J72-0683-02)	X57-5950-XX (J72-0759-12)	X58-4670-10/11 (J72-0676-02)
TK-760G/760HG SUPPLEMENT II	B51-8989-00 This service manual	148-174: K 136-162: K2 146-174: M	X54-3270-10 (J72-0683-12)*	Refer to TX-RX UNIT LIST	X58-4670-10/11 (J72-0676-02)

\* **Note:** The circuit pattern of J72-0683-02 and J72-0683-12 is the same.

### TX-RX UNIT LIST

MODEL (Market code)	TX-RX UNIT	PCB number	Frequency range (MHz)	RF Power output (W)	Power Module
TK-760G(K)	X57-5950-10	J72-0759-12	148-174	25	M677741H-32
TK-760G(K2)	X57-5950-12	J72-0759-12	136-162	25	M677741L-35
TK-760G(M)	X57-5950-21	J79-0200-09	146-174	25	RA30H1317M131
TK-760HG(K)	X57-5950-14	J72-0992-09	148-174	50	RA60H13171123
TK-760HG(K2)	X57-5950-16	J72-0759-12	136-162	50	M68702L
TK-760HG(M)	X57-5950-14	J72-0992-09	146-174	50	RA60H13171123

# TK-760G/760HG

## PARTS LIST

\* New Parts. Δ indicates safety critical components.

Parts without **Parts No.** are not supplied.

Les articles non mentionnés dans le **Parts No.** ne sont pas fournis.

Teile ohne **Parts No.** werden nicht geliefert.

L : Scandinavia

Y : PX (Far East, Hawaii)

C : China

K : USA

T : England

X : Australia

P : Canada

E : Europe

M : Other Areas

DISPLAY UNIT (X54-3270-10)  
TX-RX UNIT (X57-5950-XX)

Ref. No.	Address	New parts	Parts No.	Description	Desti-nation	Ref. No.	Address	New parts	Parts No.	Description	Desti-nation
<b>DISPLAY UNIT (X54-3270-10)</b>											
D802-805			B30-2220-05	LED(YELLOW)		C47			C92-0561-05	CHIP EL 22UF 16WV	
C801-803			CC73GCH1H101J	CHIP C 100PF J		C49			CC73GCH1H470J	CHIP C 47PF J	M
C804			CK73GF1A105Z	CHIP C 1.0UF Z		C49			CK73GB1H102K	CHIP C 1000PF K	K,K2,HK
C805			CK73GB1H102K	CHIP C 1000PF K		C49			CK73GB1H102K	CHIP C 1000PF K	HM,HK2
C806,807			CK73GB1H471K	CHIP C 470PF K		C50			CC73GCH1H220J	CHIP C 22PF J	
CN801			E40-6020-05	PIN ASSY		C51			CK73GB1C104K	CHIP C 0.10UF K	
L801			L92-0138-05	CHIP FERRITE		C52			CC73GCH1H680J	CHIP C 68PF J	K,K2,HK
R801-803			RK73GB2A103J	CHIP R 10K J 1/10W		C52			CC73GCH1H680J	CHIP C 68PF J	HM,HK2
R804			RK73GB2A473J	CHIP R 47K J 1/10W		C52			CC73GCH1H820J	CHIP C 82PF J	M
R805			RK73GB2A474J	CHIP R 470K J 1/10W		C53			CK73GB1C104K	CHIP C 0.10UF K	
R806			RK73GB2A000J	CHIP R 0 J 1/10W		C54			CK73GB1H103K	CHIP C 0.010UF K	
R808			RK73GB2A392J	CHIP R 3.9K J 1/10W		C56			CC73GCH1H200J	CHIP C 20PF J	M
R809			RK73FB2B270J	CHIP R 27 J 1/8W		C56			CC73GCH1H220J	CHIP C 22PF J	K,K2,HK
D801			MA2S111-F	DIODE		C56			CC73GCH1H220J	CHIP C 22PF J	HM,HK2
D808			DA204U	DIODE		C57			CC73GCH1H080B	CHIP C 8.0PF B	M
IC801			PT6523LQ(L)	MOS-IC		C58			CK73GB1E223K	CHIP C 0.022UF K	
Q801			2SB1132(Q,R)	TRANSISTOR		C60,61			CK73GB1H102K	CHIP C 1000PF K	
<b>TX-RX UNIT (X57-5950-XX) -10: K -12: K2 -14: HK, HM -16: HK2 -21: M</b>						C62			CC73GCH1H101J	CHIP C 100PF J	K,K2,HK
D509-514			B30-2050-05	LED		C62			CC73GCH1H470J	CHIP C 47PF J	M
D521			B30-2151-05	LED(RED/GRN)		C63			CK73GB1C104K	CHIP C 0.10UF K	
C1 -11			CK73GB1H102K	CHIP C 1000PF K		C64			CK73GB1H103K	CHIP C 0.010UF K	
C13 -19			CK73GB1H102K	CHIP C 1000PF K		C66,67			CK73GB1H102K	CHIP C 1000PF K	
C20			CS77BA0J4R7M	CHIP TNTL 4.7UF 6.3WV		C69			CK73GB1C104K	CHIP C 0.10UF K	
C21			CK73GB1H102K	CHIP C 1000PF K		C70			CS77BA0J4R7M	CHIP TNTL 4.7UF 6.3WV	
C22			CK73GB1C104K	CHIP C 0.10UF K		C72			CS77BA0J4R7M	CHIP TNTL 4.7UF 6.3WV	
C23,24			CS77BA0J4R7M	CHIP TNTL 4.7UF 6.3WV		C74,75			CK73GB1H102K	CHIP C 1000PF K	
C26			CK73GB1H102K	CHIP C 1000PF K		C77			C90-4150-05	ELECTRO 220UF 10WV	
C29			CS77BA0J4R7M	CHIP TNTL 4.7UF 6.3WV		C78			CK73GB1C104K	CHIP C 0.10UF K	
C30			CC73GCH1H050C	CHIP C 5.0PF C		C79-81			CK73GB1H102K	CHIP C 1000PF K	
C31			CC73GCH1H470J	CHIP C 47PF J	M	C82			CS77BA0J4R7M	CHIP TNTL 4.7UF 6.3WV	
C31			CK73GB1H102K	CHIP C 1000PF K	K,K2,HK	C83			CC73GCH1H270J	CHIP C 27PF J	
C31			CK73GB1H102K	CHIP C 1000PF K	HM,HK2	C84			CS77BA0J4R7M	CHIP TNTL 4.7UF 6.3WV	
C32		*	CS77CA0J150M	CHIP TNTL 15UF 6.3WV		C86		*	CS77CA0J150M	CHIP TNTL 15UF 6.3WV	
C33			CC73GCH1H220J	CHIP C 22PF J		C87			CC73GCH1H330J	CHIP C 33PF J	
C35			CK73GB1C104K	CHIP C 0.10UF K		C88			CK73GB1H103K	CHIP C 0.010UF K	
C36			CK73GB1H102K	CHIP C 1000PF K		C91			CC73GCH1H050C	CHIP C 5.0PF C	
C37			CK73FB1C334K	CHIP C 0.33UF K		C92			CK73GB1H102K	CHIP C 1000PF K	
C40,41			CK73GB1H103K	CHIP C 0.010UF K		C93			C92-0863-05	CHIP TNTL 0.047UF 35WV	
C43			CS77BA0J4R7M	CHIP TNTL 4.7UF 6.3WV		C94			CK73GB1H102K	CHIP C 1000PF K	
C44			CK73GB1H271K	CHIP C 270PF K	M	C95			CC73GCH1H020B	CHIP C 2.0PF B	
C44			CK73GB1H331K	CHIP C 330PF K	K,K2,HK	C96			CK73GB1H102K	CHIP C 1000PF K	
C44			CK73GB1H331K	CHIP C 330PF K	HM,HK2	C97			CS77CD20J680M	CHIP TNTL 68UF 6.3WV	
C45			CK73GB1H102K	CHIP C 1000PF K		C98			CK73GB1H103K	CHIP C 0.010UF K	
C46			CK73GB1H103K	CHIP C 0.010UF K		C99			CS77CA1C010M	CHIP TNTL 1.0UF 16WV	
						C100			CK73GB1H102K	CHIP C 1000PF K	
						C101			CC73GCH1H040C	CHIP C 4.0PF C	
						C102,103			CK73GB1H102K	CHIP C 1000PF K	
						C104			CS77CA1VR22M	CHIP TNTL 0.22UF 35WV	
						C105			CK73GB1H102K	CHIP C 1000PF K	
						C106			CC73GCH1H160J	CHIP C 16PF J	M
						C106			CC73GCH1H180J	CHIP C 18PF J	K,K2,HK
						C106			CC73GCH1H180J	CHIP C 18PF J	HM,HK2
						C107			CK73GB1H102K	CHIP C 1000PF K	
						C110			CC73GCH1H180J	CHIP C 18PF J	
						C111			CC73GCH1H040C	CHIP C 4.0PF C	

K: TK-760G(K) K2: TK-760G(K2) M: TK-760G(M)

HK: TK-760HG(K) HK2: TK-760HG(K2) HM: TK-760HG(M)

# TK-760G/760HG

## PARTS LIST

### TX-RX UNIT (X57-5950-XX)

Ref. No.	Address	New parts	Parts No.	Description	Destination	Ref. No.	Address	New parts	Parts No.	Description	Destination
C112			CK73GB1H102K	CHIP C 1000PF K		C160,161			CE32BD1E470M	CHIP EL 47UF 25WV	
C113			CS77BA0J4R7M	CHIP TNTL 4.7UF 6.3WV		C162			CK73GB1H102K	CHIP C 1000PF K	K,K2,HK2
C114			CS77CA1C3R3M	CHIP TNTL 3.3UF 16WV		C163			CC73GCH1H010B	CHIP C 1.0PF B	K,K2,HK
C115			CK73GB1H102K	CHIP C 1000PF K		C163			CC73GCH1H010B	CHIP C 1.0PF B	HM,HK2
C116			CK73GB1H103K	CHIP C 0.010UF K		C163			CC73GCH1H1R5B	CHIP C 1.5PF B	M
C117			CK73GB1H102K	CHIP C 1000PF K		C164			CK73GB1H102K	CHIP C 1000PF K	
C118			CC73GCH1H100D	CHIP C 10PF D		C165			CE32BD1E470M	CHIP EL 47UF 25WV	
C119			CK73GB1H103K	CHIP C 0.010UF K		C166	*		C90-4139-05	ELECTRO 470UF 25WV	
C120			CC73GCH1H220J	CHIP C 22PF J	K,M,HK	C167			CC73GCH1H150J	CHIP C 15PF J	
C120			CC73GCH1H220J	CHIP C 22PF J	HM	C168-170			CK73GB1H102K	CHIP C 1000PF K	K,K2,HK2
C120			CC73GCH1H330J	CHIP C 33PF J	K2,HK2	C169			CK73GB1H102K	CHIP C 1000PF K	M,HK,HM
C121			CK73GB1H102K	CHIP C 1000PF K		C171			CC73GCH1H020B	CHIP C 2.0PF B	
C122,123			CK73GB1C104K	CHIP C 0.10UF K		C172	*		C90-4139-05	ELECTRO 470UF 25WV	
C124			CC73GCH1H101J	CHIP C 100PF J	K,K2,HK	C173			CK73GB1C104K	CHIP C 0.10UF K	
C124			CC73GCH1H101J	CHIP C 100PF J	HM,HK2	C174			CK73GB1H102K	CHIP C 1000PF K	K,K2,HK2
C124			CK73GB1H102K	CHIP C 1000PF K	M	C175			CC73GCH1H080D	CHIP C 8.0PF D	K,HK,HM
C125			CS77CA1C010M	CHIP TNTL 1.0UF 16WV		C175			CC73GCH1H100C	CHIP C 10PF C	M
C126			CC73GCH1H180J	CHIP C 18PF J	K,K2,HK	C175			CC73GCH1H100D	CHIP C 10PF D	K2,HK2
C126			CC73GCH1H180J	CHIP C 18PF J	HM,HK2	C177			CK73GB1C104K	CHIP C 0.10UF K	M
C126			CC73GCH1H220J	CHIP C 22PF J	M	C177			CK73GB1H102K	CHIP C 1000PF K	K,K2,HK
C127			CK73GB1C104K	CHIP C 0.10UF K	M	C177			CK73GB1H102K	CHIP C 1000PF K	HM,HK2
C127			CK73GB1H103K	CHIP C 0.010UF K	K,K2,HK	C179			CK73GB1H102K	CHIP C 1000PF K	
C127			CK73GB1H103K	CHIP C 0.010UF K	HM,HK2	C180			CK73GB1H103K	CHIP C 0.010UF K	
C128			CS77CA1A3R3M	CHIP TNTL 3.3UF 10WV		C181			CC73FCH1H120J	CHIP C 12PF J	K,K2
C129			CK73FF1C105Z	CHIP C 1.0UF Z		C181			CC73FCH1H390J	CHIP C 39PF J	HK2
C130			CK73GB1H103K	CHIP C 0.010UF K		C182,183			CK73GB1H102K	CHIP C 1000PF K	HK2
C131-133			CK73GB1H102K	CHIP C 1000PF K		C183			CK73GB1H102K	CHIP C 1000PF K	K,M,K2
C134			CK73FB1E104K	CHIP C 0.10UF K		C183			CK73GB1H102K	CHIP C 1000PF K	HK,HM
C135			CC73GCH1H060B	CHIP C 6.0PF B	M	C185			CK73GB1C104K	CHIP C 0.10UF K	
C135			CC73GCH1H090D	CHIP C 9.0PF D	K,HK,HM	C186,187			CK73GB1H102K	CHIP C 1000PF K	
C135			CC73GCH1H120J	CHIP C 12PF J	K2,HK2	C188			CC73GCH1H060D	CHIP C 6.0PF D	HK2
C136			CK73GB1C104K	CHIP C 0.10UF K		C189,190			CK73GB1H102K	CHIP C 1000PF K	K,K2,HK2
C137			CC73GCH1H101J	CHIP C 100PF J		C190			CK73GB1H102K	CHIP C 1000PF K	M,HK,HM
C138			CK73FB1E104K	CHIP C 0.10UF K		C191			CC73GCH1H080D	CHIP C 8.0PF D	M
C139			CK73GB1H102K	CHIP C 1000PF K		C192			CK73GB1H102K	CHIP C 1000PF K	
C141			CE32BD1E470M	CHIP EL 47UF 25WV		C194			CK73GB1C104K	CHIP C 0.10UF K	
C142-144			CK73GB1H102K	CHIP C 1000PF K		C195			CE32BD1E470M	CHIP EL 47UF 25WV	K,K2,HK2
C146			CK73GB1C104K	CHIP C 0.10UF K	M	C195			CS77CA1C3R3M	CHIP TNTL 3.3UF 16WV	M,HK,HM
C146-149			CK73GB1H102K	CHIP C 1000PF K	K,K2,HK	C196			CK73GB1H102K	CHIP C 1000PF K	
C146-149			CK73GB1H102K	CHIP C 1000PF K	HM,HK2	C198			CC73GCH1H080D	CHIP C 8.0PF D	M
C147,148			CK73GB1H102K	CHIP C 1000PF K	M	C198			CK73GB1H102K	CHIP C 1000PF K	K,K2,HK
C149			CK73GB1H103K	CHIP C 0.010UF K	M	C198			CK73GB1H102K	CHIP C 1000PF K	HM,HK2
C150			CK73FF1C105Z	CHIP C 1.0UF Z		C200			CK73GB1H102K	CHIP C 1000PF K	K,M,K2
C151			CK73GB1H102K	CHIP C 1000PF K		C200			CK73GB1H102K	CHIP C 1000PF K	HK,HM
C152			CC73GCH1H030C	CHIP C 3.0PF C	K,HK,HM	C201			CK73GB1C104K	CHIP C 0.10UF K	K,M,K2
C152			CC73GCH1H050C	CHIP C 5.0PF C	K2,HK2	C201			CK73GB1C104K	CHIP C 0.10UF K	HK,HM
C152			CC73GCH1H3R5B	CHIP C 3.5PF B	M	C203			CK73GB1H102K	CHIP C 1000PF K	
C153			CC73GCH1H181J	CHIP C 180PF J	M	C204			CS77CA1C010M	CHIP TNTL 1.0UF 16WV	
C153			CC73GCH1H330J	CHIP C 33PF J	K,K2,HK	C205			C93-0550-05	CHIP C 1.0PF C	HK,HM
C153			CC73GCH1H330J	CHIP C 33PF J	HM,HK2	C205			C93-0558-05	CHIP C 8.0PF D	M,K2
C154			CK73GB1H102K	CHIP C 1000PF K		C205			C93-0560-05	CHIP C 10PF D	K
C155			CC73GCH1H200J	CHIP C 20PF J	M	C205			C93-0563-05	CHIP C 18PF J	HK2
C155			CC73GCH1H220J	CHIP C 22PF J	K,K2,HK	C207			CK73GB1H103K	CHIP C 0.010UF K	
C155			CC73GCH1H220J	CHIP C 22PF J	HM,HK2	C208			CC73FCH1H030C	CHIP C 3.0PF C	K,HK,HM
C156,157			CK73GB1H102K	CHIP C 1000PF K		C208			CC73FCH1H040C	CHIP C 4.0PF C	K2,HK2
C158			CC73GCH1H220J	CHIP C 22PF J	HK2	C208			CC73GCH1H060D	CHIP C 6.0PF D	M
C158			CC73GCH1H270J	CHIP C 27PF J	M,HK,HM	C209			C93-0559-05	CHIP C 9.0PF D	M
C158			CC73GCH1H390J	CHIP C 39PF J	K,K2	C209			C93-0560-05	CHIP C 10PF D	HK,HM
C159			CC73GCH1H130J	CHIP C 13PF J	M,HK,HM	C209			C93-0563-05	CHIP C 18PF J	K2
C159			CC73GCH1H180J	CHIP C 18PF J	K,K2,HK2	C209			C93-0564-05	CHIP C 22PF J	K,HK2

# TK-760G/760HG

## PARTS LIST

TX-RX UNIT (X57-5950-XX)

Ref. No.	Address	New parts	Parts No.	Description	Desti-nation	Ref. No.	Address	New parts	Parts No.	Description	Desti-nation
C210			CK73GB1H103K	CHIP C 0.010UF K		C508			CK73GB1H472K	CHIP C 4700PF K	
C211			C93-0564-05	CHIP C 22PF J		C509			CS77BA0J4R7M	CHIP TNL 4.7UF 6.3WV	
C212			CK73GB1H102K	CHIP C 1000PF K		C514			CC73GCH1H020B	CHIP C 2.0PF B	M
C213			C93-0563-05	CHIP C 18PF J		C514			CC73GCH1H680J	CHIP C 68PF J	K,K2,HK
C214			C93-0603-05	CHIP C 1000PF K		C514			CC73GCH1H680J	CHIP C 68PF J	HM,HK2
C215			C93-0557-05	CHIP C 7.0PF D	HK,HM	C515			CK73GB1H103K	CHIP C 0.010UF K	
C215			C93-0560-05	CHIP C 10PF D	M,HK2	C516			CC73GCH1H150G	CHIP C 15PF G	M
C215			C93-0561-05	CHIP C 12PF J	K,K2	C516			CC73GCH1H270J	CHIP C 27PF J	K,K2,HK
C216			CC73GCH1H0R5B	CHIP C 0.5PF B		C516			CC73GCH1H270J	CHIP C 27PF J	HM,HK2
C217			CC73GCH1H010B	CHIP C 1.0PF B	K,M,K2	C517			CK73GB1C683K	CHIP C 0.068UF K	
C217			CC73GCH1H010B	CHIP C 1.0PF B	HK,HM	C518			CC73GCH1H150G	CHIP C 15PF G	M
C217			CC73GCH1H020B	CHIP C 2.0PF B	HK2	C518			CC73GCH1H270J	CHIP C 27PF J	K,K2,HK
C218			CK73GB1C104K	CHIP C 0.10UF K	K,M,HK	C518			CC73GCH1H270J	CHIP C 27PF J	HM,HK2
C218			CK73GB1C104K	CHIP C 0.10UF K	HM,HK2	C519			CK73GB1H102K	CHIP C 1000PF K	
C219			C93-0561-05	CHIP C 12PF J	HK,HM	C520			CK73GB1C104K	CHIP C 0.10UF K	
C219			C93-0562-05	CHIP C 15PF J	M	C521			CK73GB1H102K	CHIP C 1000PF K	
C219			C93-0563-05	CHIP C 18PF J	HK2	C522			CS77BA0J4R7M	CHIP TNL 4.7UF 6.3WV	
C219			C93-0565-05	CHIP C 27PF J	K,K2	C523			CC73GCH1H221J	CHIP C 220PF J	
C220			CK73GB1H102K	CHIP C 1000PF K		C524			CK73GB1H103K	CHIP C 0.010UF K	
C221			C93-0556-05	CHIP C 6.0PF D	HK,HM	C525			CK73GB1E123K	CHIP C 0.012UF K	
C221			C93-0561-05	CHIP C 12PF J	M	C526			CK73GB1C683K	CHIP C 0.068UF K	
C221			C93-0562-05	CHIP C 15PF J	HK2	C527			CK73GB1H222K	CHIP C 2200PF K	
C221			C93-0563-05	CHIP C 18PF J	K	C528			CK73GB1H103K	CHIP C 0.010UF K	
C221			C93-0565-05	CHIP C 27PF J	K2	C529			CK73GB1H272K	CHIP C 2700PF K	
C222			CC73GCH1H0R5B	CHIP C 0.5PF B		C530			CK73GB1H152K	CHIP C 1500PF K	
C223			CC73GCH1H010B	CHIP C 1.0PF B	K,HK2	C531			CK73GB1H272K	CHIP C 2700PF K	
C223			CC73GCH1H020B	CHIP C 2.0PF B	M,K2,HK	C532,533			CK73GB1C104K	CHIP C 0.10UF K	
C223			CC73GCH1H020B	CHIP C 2.0PF B	HM	C534,535			CK73GB1H103K	CHIP C 0.010UF K	
C224			CK73GB1H102K	CHIP C 1000PF K		C536,537			CK73GB1C104K	CHIP C 0.10UF K	
C230,231			CK73GB1C104K	CHIP C 0.10UF K		C538			CS77BA0J100M	CHIP TNL 10UF 6.3WV	
C241			C93-0553-05	CHIP C 3.0PF C	HK2	C539			CK73GB1H103K	CHIP C 0.010UF K	
C241			C93-0554-05	CHIP C 4.0PF C	K	C540,541			CK73GB1C104K	CHIP C 0.10UF K	
C241			C93-0555-05	CHIP C 5.0PF C	K2	C542			CC73GCH1H331J	CHIP C 330PF J	
C241			C93-0556-05	CHIP C 6.0PF D	M,HK,HM	C543			CK73GB1H102K	CHIP C 1000PF K	
C245			CK73GB1C104K	CHIP C 0.10UF K	HK2	C544-546			CK73GB1H562K	CHIP C 5600PF K	
C248			C92-0949-05	CHIP TNL 4.7UF 16WV		C547			CC73GCH1H030C	CHIP C 3.0PF C	
C251			CK73GB1H102K	CHIP C 1000PF K	HK2	C548-550			CK73GB1H272K	CHIP C 2700PF K	
C252			CK73GB1C104K	CHIP C 0.10UF K	HK2	C551			CC73GCH1H151J	CHIP C 150PF J	
C259			CK73GB1C104K	CHIP C 0.10UF K		C552			CC73GCH1H030C	CHIP C 3.0PF C	
C264			CC73GCH1H220J	CHIP C 22PF J	M	C553			CK73GB1H102K	CHIP C 1000PF K	
C265			CK73GB1H102K	CHIP C 1000PF K	HK2	C554			CK73GB1H122K	CHIP C 1200PF K	
C270			CK73GB1C104K	CHIP C 0.10UF K		C555			CS77BA0J100M	CHIP TNL 10UF 6.3WV	
C271			CK73GB1H681K	CHIP C 680PF K		C556			CK73GB1C333K	CHIP C 0.033UF K	
C274			CK73GB1C104K	CHIP C 0.10UF K	K,K2,HK2	C557			CK73GB1C104K	CHIP C 0.10UF K	
C275			CS77CA1C010M	CHIP TNL 1.0UF 16WV	K2	C558			CC73GCH1H101J	CHIP C 100PF J	
C276			CK73GB1H102K	CHIP C 1000PF K	HK2	C559			CK73GB1H102K	CHIP C 1000PF K	
C277			CK73GB1H102K	CHIP C 1000PF K	M,HK,HM	C560-563			CK73GB1C104K	CHIP C 0.10UF K	
C278			CK73GB1C104K	CHIP C 0.10UF K	M,HK,HM	C564			CS77BA0J4R7M	CHIP TNL 4.7UF 6.3WV	
C279			CK73GB1H102K	CHIP C 1000PF K	M,HK,HM	C565,566			CK73GB1H472K	CHIP C 4700PF K	
C280			CS77CA1ER47M	CHIP TNL 0.47UF 25WV	M,HK,HM	C567			CC73GCH1H101J	CHIP C 100PF J	
C281			CS77BA1E010M	CHIP TNL 1.0UF 25WV	M,HK,HM	C568			CS77BA0J4R7M	CHIP TNL 4.7UF 6.3WV	
C282			CK73GB1H102K	CHIP C 1000PF K	M	C569			CK73GB1E223K	CHIP C 0.022UF K	
C283			CC73GCH1H220J	CHIP C 22PF J	M	C570			CK73FF1C105Z	CHIP C 1.0UF Z	
C285-288			CK73GB1C104K	CHIP C 0.10UF K	M	C571,572			CK73GB1H102K	CHIP C 1000PF K	
C501			CK73GB1H102K	CHIP C 1000PF K		C573			CK73FB1H563K	CHIP C 0.056UF K	
C502			CK73GB1C104K	CHIP C 0.10UF K		C574			CC73GCH1H470J	CHIP C 47PF J	
C503			CK73GB1H471K	CHIP C 470PF K		C575			CK73GB1H102K	CHIP C 1000PF K	
C504			CK73GB1H103K	CHIP C 0.010UF K		C576			CK73GB1C104K	CHIP C 0.10UF K	
C505			CK73GB1C104K	CHIP C 0.10UF K		C577,578			CK73GB1H103K	CHIP C 0.010UF K	
C506,507			CK73GB1H103K	CHIP C 0.010UF K		C579			CC73GCH1H101J	CHIP C 100PF J	

K: TK-760G(K) K2: TK-760G(K2) M: TK-760G(M)  
 HK: TK-760HG(K) HK2: TK-760HG(K2) HM: TK-760HG(M)

# TK-760G/760HG

## PARTS LIST

### TX-RX UNIT (X57-5950-XX)

Ref. No.	Address	New parts	Parts No.	Description	Destination	Ref. No.	Address	New parts	Parts No.	Description	Destination
C580			CK73GB1C104K	CHIP C 0.10UF K		L6			L40-1581-86	SMALL FIXED INDUCTOR(0.15UH)	HM,HK2
C581			CK73GB1H102K	CHIP C 1000PF K		L6			L40-1885-92	SMALL FIXED INDUCTOR(180NH)	M
C582			CK73GB1C473K	CHIP C 0.047UF K		L7			L41-4785-39	SMALL FIXED INDUCTOR(0.47UH)	K,K2,HK
C583			CS77BA0J100M	CHIP TNTL 10UF 6.3WV		L7			L41-4785-39	SMALL FIXED INDUCTOR(0.47UH)	HM,HK2
C584			CK73GB1H103K	CHIP C 0.010UF K		L8			L41-4785-39	SMALL FIXED INDUCTOR(0.47UH)	M
C585			CC73GCH1H101J	CHIP C 100PF J		L8			L41-8285-39	SMALL FIXED INDUCTOR(0.82UH)	K,K2,HK
C587			CK73GB1H103K	CHIP C 0.010UF K		L8			L41-8285-39	SMALL FIXED INDUCTOR(0.82UH)	HM,HK2
C589			CS77AA1A4R7M	CHIP TNTL 4.7UF 10WV		L9			L40-1085-92	SMALL FIXED INDUCTOR(100NH)	
C590			CK73GB1H102K	CHIP C 1000PF K		L10			L40-5675-92	SMALL FIXED INDUCTOR(56NH)	M
C594			CK73GB1H102K	CHIP C 1000PF K		L10			L40-6875-92	SMALL FIXED INDUCTOR(68NH)	K,K2,HK
C596			CK73GB1H102K	CHIP C 1000PF K		L10			L40-6875-92	SMALL FIXED INDUCTOR(68NH)	HM,HK2
C597			CC73GCH1H101J	CHIP C 100PF J		L11			L34-4788-05	COIL	
C598			CK73GB1H102K	CHIP C 1000PF K		L12			L41-1085-33	SMALL FIXED INDUCTOR(0.1UH)	M,HK,HM
C599			CC73GCH1H101J	CHIP C 100PF J		L12			L41-3375-33	SMALL FIXED INDUCTOR(0.033UH)	K,K2,HK2
C600			CK73GB1H102K	CHIP C 1000PF K		L13			L34-4789-05	COIL	
C601,602			CC73GCH1H101J	CHIP C 100PF J		L14			L41-6875-33	SMALL FIXED INDUCTOR(0.068UH)	K,K2,HK2
C603			CK73GB1H102K	CHIP C 1000PF K		L15			L34-4789-05	COIL	
C604-606			CC73GCH1H101J	CHIP C 100PF J		L17			L92-0179-05	CHIP FERRITE	
C608-610			CC73GCH1H101J	CHIP C 100PF J		L18			L34-4788-05	COIL	
C611,612			CK73GB1H471K	CHIP C 470PF K		L20		*	L34-4481-15	AIR-CORE COIL(6T)	K,M,HK
C613			CC73GCH1H101J	CHIP C 100PF J		L20		*	L34-4481-15	AIR-CORE COIL(6T)	HM,HK2
C615			CK73GB1H471K	CHIP C 470PF K		L21			L34-4478-15	AIR-CORE COIL(9.5T)	
C616			CC73GCH1H101J	CHIP C 100PF J		L22		*	L34-4480-15	AIR-CORE COIL(5T)	
C618			CK73GB1H102K	CHIP C 1000PF K		L23			L34-4655-05	AIR-CORE COIL(5T)	
C620			CK73GB1H471K	CHIP C 470PF K		L24		*	L34-4481-15	AIR-CORE COIL(6T)	
C621			CK73GB1H102K	CHIP C 1000PF K		L25			L34-4478-15	AIR-CORE COIL(9.5T)	
C623			CK73GB1H102K	CHIP C 1000PF K		L26			L40-4775-92	SMALL FIXED INDUCTOR(47NH)	
C626			CK73GB1C104K	CHIP C 0.10UF K		L27			L40-1581-86	SMALL FIXED INDUCTOR(0.15UH)	K,K2,HK
C628			CK73GB1C104K	CHIP C 0.10UF K		L27			L40-1581-86	SMALL FIXED INDUCTOR(0.15UH)	HM,HK2
C629			CC73GCH1H470J	CHIP C 47PF J		L33			L92-0179-05	CHIP FERRITE	K,K2
C630			CS77BA0J4R7M	CHIP TNTL 4.7UF 6.3WV		L33 ,34			L92-0179-05	CHIP FERRITE	M,HK,HM
C631			CK73GB1H103K	CHIP C 0.010UF K		L33 ,34			L92-0179-05	CHIP FERRITE	HK2
C632			CK73FF1C105Z	CHIP C 1.0UF Z		L35		*	L34-4480-15	AIR-CORE COIL	K2
C633			CK73GB1C104K	CHIP C 0.10UF K		L35			L40-2285-92	SMALL FIXED INDUCTOR(220NH)	M
C720			CS77BA0J100M	CHIP TNTL 10UF 6.3WV		L501			L92-0138-05	CHIP FERRITE	
CN1		*	E40-6826-05	PIN ASSY	M	L503,504			L92-0138-05	CHIP FERRITE	
CN1		*	E41-3093-05	PIN ASSY	K,K2,HK	L510			L92-0138-05	CHIP FERRITE	
CN1		*	E41-3093-05	PIN ASSY	HM,HK2	X1			L77-1998-05	TCXO (16.8MHZ)	K,K2,HK
CN2			E40-6805-05	FLAT CABLE CONNECTOR		X1			L77-1998-05	TCXO (16.8MHZ)	HM,HK2
CN3			E41-1683-05	PIN ASSY		X1			L77-3028-05	TCXO (16.8MHZ)	M
CN4			E41-2834-05	PIN ASSY		X501			L77-1708-15	CRYSTAL RESONATOR(3.579545MHZ)	
CN5			E40-5738-05	PIN ASSY	K,K2,HK	X502		*	L77-3038-05	CRYSTAL RESONATOR(9.8304MHZ)	M
CN5			E40-5738-05	PIN ASSY	HM,HK2	X502			L78-1418-05	RESONATOR (9.8304MHZ)	K,K2,HK
CN5		*	E41-3085-05	PIN ASSY	M	X502			L78-1418-05	RESONATOR (9.8304MHZ)	HM,HK2
CN7			E41-1683-05	PIN ASSY		XF1			L71-0551-45	MCF (49.95MHZ)	
CN8			E41-1682-05	PIN ASSY		CP501-505			R90-0741-05	MULTIPLE RESISTOR	
CN501			E40-6805-05	FLAT CABLE CONNECTOR		CP508-514			R90-0741-05	MULTIPLE RESISTOR	
J1			E11-0442-05	3.5D PHONE JACK(3P)		CP516-524			R90-0741-05	MULTIPLE RESISTOR	
J501			E58-0522-05	MODULAR JACK		CP526,527			R90-0741-05	MULTIPLE RESISTOR	
						CP529-536			R90-0741-05	MULTIPLE RESISTOR	
F1			F53-0108-05	FUSE		CP538			R90-0741-05	MULTIPLE RESISTOR	
CF1			L72-0999-05	CERAMIC FILTER		CP539			RK75GB1J102J	CHIP-COM 1.0K J 1/16W	
CF2			L72-0993-05	CERAMIC FILTER		R1			RK73GB2A000J	CHIP R 0 J 1/10W	
L1			L41-1005-33	SMALL FIXED INDUCTOR(10UH)		R2			RK73GB2A102J	CHIP R 1.0K J 1/10W	
L2			L40-1091-86	SMALL FIXED INDUCTOR(1.0UH)	M	R3			RK73GB2A000J	CHIP R 0 J 1/10W	
L2 -4			L40-3381-86	SMALL FIXED INDUCTOR(0.33UH)	K,K2,HK						
L2 -4			L40-3381-86	SMALL FIXED INDUCTOR(0.33UH)	HM,HK2	R4			RK73GB2A333J	CHIP R 33K J 1/10W	
L3 ,4			L40-3381-86	SMALL FIXED INDUCTOR(0.33UH)	M	R6			RK73GB2A000J	CHIP R 0 J 1/10W	
L5			L34-4725-05	COIL		R7 ,8			RK73GB2A102J	CHIP R 1.0K J 1/10W	
L6			L40-1581-86	SMALL FIXED INDUCTOR(0.15UH)	K,K2,HK	R9 ,10			RK73GB2A000J	CHIP R 0 J 1/10W	
						R11			RK73GB2A102J	CHIP R 1.0K J 1/10W	

# TK-760G/760HG

## PARTS LIST

TX-RX UNIT (X57-5950-XX)

Ref. No.	Address	New parts	Parts No.	Description	Desti-nation	Ref. No.	Address	New parts	Parts No.	Description	Desti-nation
R12			RK73GB2A104J	CHIP R 100K J 1/10W		R72			RK73GB2A000J	CHIP R 0 J 1/10W	
R13			RK73GB2A473J	CHIP R 47K J 1/10W		R75			RK73GB2A471J	CHIP R 470 J 1/10W	
R14			RK73GB2A474J	CHIP R 470K J 1/10W		R76			RK73GB2A223J	CHIP R 22K J 1/10W	
R15			RK73GB2A104J	CHIP R 100K J 1/10W		R77			RK73GB2A154J	CHIP R 150K J 1/10W	K,M,HK
R16			RK73GB2A220J	CHIP R 22 J 1/10W		R77			RK73GB2A154J	CHIP R 150K J 1/10W	HM
R17			RK73GB2A154J	CHIP R 150K J 1/10W	K,K2,HK	R77			RK73GB2A184J	CHIP R 180K J 1/10W	K2,HK2
R17			RK73GB2A154J	CHIP R 150K J 1/10W	HM,HK2	R78			RK73GB2A104J	CHIP R 100K J 1/10W	
R17			RK73GB2A224J	CHIP R 220K J 1/10W	M	R79			RK73GB2A681J	CHIP R 680 J 1/10W	
R18			RK73GB2A104J	CHIP R 100K J 1/10W		R80			RK73GB2A102J	CHIP R 1.0K J 1/10W	M
R19			RK73GB2A392J	CHIP R 3.9K J 1/10W		R80			RK73GB2A471J	CHIP R 470 J 1/10W	K,K2,HK
R20			RK73GB2A224J	CHIP R 220K J 1/10W		R80			RK73GB2A471J	CHIP R 470 J 1/10W	HM,HK2
R21			RK73GB2A102J	CHIP R 1.0K J 1/10W		R81			RK73GB2A101J	CHIP R 100 J 1/10W	
R22			RK73GB2A474J	CHIP R 470K J 1/10W		R82			RK73GB2A152J	CHIP R 1.5K J 1/10W	
R23			RK73GB2A223J	CHIP R 22K J 1/10W		R83			RK73GB2A684J	CHIP R 680K J 1/10W	
R24			RK73GB2A183J	CHIP R 18K J 1/10W		R85			RK73GB2A272J	CHIP R 2.7K J 1/10W	
R25 ,26			RK73GB2A000J	CHIP R 0 J 1/10W		R86			RK73GB2A122J	CHIP R 1.2K J 1/10W	
R29			RK73GB2A000J	CHIP R 0 J 1/10W		R87			RK73GB2A102J	CHIP R 1.0K J 1/10W	
R30			RK73GB2A103J	CHIP R 10K J 1/10W		R88			RK73GB2A271J	CHIP R 270 J 1/10W	
R31			RK73GB2A152J	CHIP R 1.5K J 1/10W	K,K2,HK	R89			RK73GB2A102J	CHIP R 1.0K J 1/10W	
R31			RK73GB2A152J	CHIP R 1.5K J 1/10W	HM,HK2	R90 ,91			RK73GB2A104J	CHIP R 100K J 1/10W	
R31			RK73GB2A472J	CHIP R 4.7K J 1/10W	M	R92			RK73GB2A000J	CHIP R 0 J 1/10W	
R32			RK73GB2A103J	CHIP R 10K J 1/10W		R93			RK73GB2A152J	CHIP R 1.5K J 1/10W	
R33			RK73GB2A000J	CHIP R 0 J 1/10W		R94			RK73GB2A000J	CHIP R 0 J 1/10W	
R34			RK73GB2A104J	CHIP R 100K J 1/10W		R95			RK73GB2A103J	CHIP R 10K J 1/10W	
R35			RK73GB2A224J	CHIP R 220K J 1/10W		R97			RK73GB2A473J	CHIP R 47K J 1/10W	
R36			RK73GB2A223J	CHIP R 22K J 1/10W		R98			RK73GB2A223J	CHIP R 22K J 1/10W	
R37			RK73GB2A220J	CHIP R 22 J 1/10W		R99			RK73GB2A000J	CHIP R 0 J 1/10W	M
R38 -40			RK73GB2A103J	CHIP R 10K J 1/10W		R99			RK73GB2A271J	CHIP R 270 J 1/10W	K,K2,HK
R41			RK73GB2A104J	CHIP R 100K J 1/10W	M	R99			RK73GB2A271J	CHIP R 270 J 1/10W	HM,HK2
R41			RK73GB2A224J	CHIP R 220K J 1/10W	K,K2,HK	R100,101			RK73GB2A101J	CHIP R 100 J 1/10W	
R41			RK73GB2A224J	CHIP R 220K J 1/10W	HM,HK2	R103			RK73GB2A472J	CHIP R 4.7K J 1/10W	
R42			RK73GB2A473J	CHIP R 47K J 1/10W		R104			RK73GB2A391J	CHIP R 390 J 1/10W	M
R43			RK73GB2A683J	CHIP R 68K J 1/10W		R105			RK73GB2A470J	CHIP R 47 J 1/10W	
R44			RK73GB2A153J	CHIP R 15K J 1/10W		R106			RK73GB2A222J	CHIP R 2.2K J 1/10W	
R46			RK73GB2A223J	CHIP R 22K J 1/10W		R107			RK73GB2A473J	CHIP R 47K J 1/10W	
R47			RK73GB2A101J	CHIP R 100 J 1/10W	K,K2,HK	R108			RK73GB2A181J	CHIP R 180 J 1/10W	M,HK,HM
R47			RK73GB2A101J	CHIP R 100 J 1/10W	HM,HK2	R108			RK73GB2A271J	CHIP R 270 J 1/10W	K,K2,HK2
R47			RK73GB2A221J	CHIP R 220 J 1/10W	M	R109			RK73GB2A102J	CHIP R 1.0K J 1/10W	
R48			RK73GB2A184J	CHIP R 180K J 1/10W		R110			RK73GB2A220J	CHIP R 22 J 1/10W	K,K2,HK
R49			RK73GB2A152J	CHIP R 1.5K J 1/10W		R110			RK73GB2A220J	CHIP R 22 J 1/10W	HM,HK2
R50			RK73GB2A473J	CHIP R 47K J 1/10W		R110			RK73GB2A271J	CHIP R 270 J 1/10W	M
R51 -53			RK73GB2A102J	CHIP R 1.0K J 1/10W		R111			RK73GB2A180J	CHIP R 18 J 1/10W	K,K2,HK2
R54			RK73GB2A000J	CHIP R 0 J 1/10W		R111			RK73GB2A330J	CHIP R 33 J 1/10W	M,HK,HM
R55			RK73GB2A104J	CHIP R 100K J 1/10W		R112			RK73GB2A223J	CHIP R 22K J 1/10W	M
R56			RK73GB2A101J	CHIP R 100 J 1/10W		R112			RK73GB2A333J	CHIP R 33K J 1/10W	K,K2,HK
R57			RK73GB2A471J	CHIP R 470 J 1/10W		R112			RK73GB2A333J	CHIP R 33K J 1/10W	HM,HK2
R58			RK73GB2A332J	CHIP R 3.3K J 1/10W		R113			RK73GB2A181J	CHIP R 180 J 1/10W	M,HK,HM
R59			RK73GB2A472J	CHIP R 4.7K J 1/10W		R113			RK73GB2A271J	CHIP R 270 J 1/10W	K,K2,HK2
R60			RK73GB2A334J	CHIP R 330K J 1/10W		R114			RK73GB2A472J	CHIP R 4.7K J 1/10W	K,K2,HK
R61			RK73GB2A331J	CHIP R 330 J 1/10W		R114			RK73GB2A472J	CHIP R 4.7K J 1/10W	HM,HK2
R62			RK73GB2A224J	CHIP R 220K J 1/10W		R114,115			RK73GB2A472J	CHIP R 4.7K J 1/10W	M
R63			RK73GB2A184J	CHIP R 180K J 1/10W		R115			RK73GB2A103J	CHIP R 10K J 1/10W	K,K2,HK
R64			RK73GB2A223J	CHIP R 22K J 1/10W		R115			RK73GB2A103J	CHIP R 10K J 1/10W	HM,HK2
R65			RK73GB2A183J	CHIP R 18K J 1/10W		R116			RK73GB2A473J	CHIP R 47K J 1/10W	
R66			RK73GB2A101J	CHIP R 100 J 1/10W		R117			RK73GB2A222J	CHIP R 2.2K J 1/10W	
R67			RK73GB2A332J	CHIP R 3.3K J 1/10W		R118			RK73GB2A102J	CHIP R 1.0K J 1/10W	
R68			RK73GB2A331J	CHIP R 330 J 1/10W		R119			RK73GB2A103J	CHIP R 10K J 1/10W	
R69			RK73GB2A000J	CHIP R 0 J 1/10W		R120			RK73GB2A000J	CHIP R 0 J 1/10W	
R70			RK73GB2A562J	CHIP R 5.6K J 1/10W		R121			RK73GB2A100J	CHIP R 10 J 1/10W	
R71			RK73GB2A103J	CHIP R 10K J 1/10W		R122			RK73RB2H471J	CHIP R 470 J 1/2W	

K: TK-760G(K) K2: TK-760G(K2) M: TK-760G(M)  
 HK: TK-760HG(K) HK2: TK-760HG(K2) HM: TK-760HG(M)

# TK-760G/760HG

## PARTS LIST

### TX-RX UNIT (X57-5950-XX)

Ref. No.	Address	New parts	Parts No.	Description	Destination	Ref. No.	Address	New parts	Parts No.	Description	Destination
R123			RK73GB2A472J	CHIP R 4.7K J 1/10W		R172			RK73GB2A244J	CHIP R 240K J 1/10W	M
R124			RK73GB2A103J	CHIP R 10K J 1/10W		R172			RK73GB2A334J	CHIP R 330K J 1/10W	K,K2,HK2
R125			RK73GB2A333J	CHIP R 33K J 1/10W		R172			RK73GB2A474J	CHIP R 470K J 1/10W	HK,HM
R126			RK73GB2A471J	CHIP R 470 J 1/10W		R173			RK73GB2A222J	CHIP R 2.2K J 1/10W	HK2
R127			RK73GB2A222J	CHIP R 2.2K J 1/10W		R173			RK73GB2A332J	CHIP R 3.3K J 1/10W	K,M,K2
R128			RK73GB2A220J	CHIP R 22 J 1/10W		R173			RK73GB2A332J	CHIP R 3.3K J 1/10W	HK,HM
R129			RK73GB2A152J	CHIP R 1.5K J 1/10W		R174			RK73GB2A103J	CHIP R 10K J 1/10W	
R130			RK73GB2A103J	CHIP R 10K J 1/10W		R175			RK73GB2A682J	CHIP R 6.8K J 1/10W	
R131			RK73GB2A681J	CHIP R 680 J 1/10W		R176			RK73GB2A103J	CHIP R 10K J 1/10W	M,HK,HM
R132			RK73FB2B470J	CHIP R 47 J 1/8W	K,K2,HK2	R176			RK73GB2A104J	CHIP R 100K J 1/10W	K,K2,HK2
R133-136			RK73GB2A000J	CHIP R 0 J 1/10W		R177			RK73RB2H121J	CHIP R 120 J 1/2W	M,HK,HM
R137			RK73FB2B100J	CHIP R 10 J 1/8W	K,K2,HK2	R177			RK73RB2H151J	CHIP R 150 J 1/2W	K,K2,HK2
R138			RK73GB2A102J	CHIP R 1.0K J 1/10W		R178			RK73GB2A103J	CHIP R 10K J 1/10W	K,K2,HK2
R139			RK73GB2A103J	CHIP R 10K J 1/10W		R178			RK73GB2A822J	CHIP R 8.2K J 1/10W	M,HK,HM
R140			RK73FB2B2R2J	CHIP R 2.2 J 1/8W		R179			RK73GB2A273J	CHIP R 27K J 1/10W	HK2
R141			RK73GB2A103J	CHIP R 10K J 1/10W	K,K2,HK	R179			RK73GB2A333J	CHIP R 33K J 1/10W	M
R141			RK73GB2A103J	CHIP R 10K J 1/10W	HM,HK2	R179			RK73GB2A563J	CHIP R 56K J 1/10W	HK,HM
R141			RK73GB2A272J	CHIP R 2.7K J 1/10W	M	R179-181			RK73GB2A223J	CHIP R 22K J 1/10W	K,K2
R142			RK73GB2A473J	CHIP R 47K J 1/10W		R180			RK73GB2A332J	CHIP R 3.3K J 1/10W	HK,HM
R144			RK73RB2H220J	CHIP R 22 J 1/2W	K,K2,HK2	R180,181			RK73GB2A104J	CHIP R 100K J 1/10W	M
R145,146			RK73GB2A473J	CHIP R 47K J 1/10W		R180,181			RK73GB2A223J	CHIP R 22K J 1/10W	HK2
R147			RK73GB2A102J	CHIP R 1.0K J 1/10W	K,HK,HM	R181			RK73GB2A562J	CHIP R 5.6K J 1/10W	HK,HM
R147			RK73GB2A152J	CHIP R 1.5K J 1/10W	M,K2,HK2	R182			RK73GB2A102J	CHIP R 1.0K J 1/10W	
R148			RK73GB2A104J	CHIP R 100K J 1/10W		R183			RK73FB2B000J	CHIP R 0 J 1/8W	
R149			RK73GB2A470J	CHIP R 47 J 1/10W		R184			RK73GB2A000J	CHIP R 0 J 1/10W	K,K2,HK
R150			RK73GB2A104J	CHIP R 100K J 1/10W		R184			RK73GB2A000J	CHIP R 0 J 1/10W	HM,HK2
R151			RK73FB2B331J	CHIP R 330 J 1/8W	K,K2	R185			RK73GB2A473J	CHIP R 47K J 1/10W	
R151			RK73FB2B471J	CHIP R 470 J 1/8W	M,HK2	R186			RK73GB2A000J	CHIP R 0 J 1/10W	K,M,K2
R151			RK73FB2B821J	CHIP R 820 J 1/8W	HK,HM	R186			RK73GB2A000J	CHIP R 0 J 1/10W	HK,HM
R152			RK73GB2A000J	CHIP R 0 J 1/10W		R186			RK73GB2A100J	CHIP R 10 J 1/10W	HK2
R153			RK73FB2B000J	CHIP R 0 J 1/8W		R188			RK73GB2A102J	CHIP R 1.0K J 1/10W	
R154			RK73GB2A152J	CHIP R 1.5K J 1/10W		R189			RK73GB2A101J	CHIP R 100 J 1/10W	
R155			RK73FB2B100J	CHIP R 10 J 1/8W	M	R190			RK73GB2A473J	CHIP R 47K J 1/10W	
R155			RK73FB2B120J	CHIP R 12 J 1/8W	HK2	R192			RK73GB2A103J	CHIP R 10K J 1/10W	
R155			RK73FB2B150J	CHIP R 15 J 1/8W	K,K2	R193			RK73GB2A102J	CHIP R 1.0K J 1/10W	
R155			RK73FB2B5R6J	CHIP R 5.6 J 1/8W	HK,HM	R196			RK73GB2A332J	CHIP R 3.3K J 1/10W	
R157			RK73GB2A271J	CHIP R 270 J 1/10W	K,K2,HK	R197			RK73GB2A000J	CHIP R 0 J 1/10W	
R157			RK73GB2A271J	CHIP R 270 J 1/10W	HM,HK2	R201,202			RK73GB2A000J	CHIP R 0 J 1/10W	
R157			RK73GB2A391J	CHIP R 390 J 1/10W	M	R208			RK73FB2B000J	CHIP R 0 J 1/8W	
R159			RK73GB2A473J	CHIP R 47K J 1/10W		R210			RK73GB2A000J	CHIP R 0 J 1/10W	
R160			RK73FB2B331J	CHIP R 330 J 1/8W	K,K2	R219-221			RK73GB2A000J	CHIP R 0 J 1/10W	
R160			RK73FB2B471J	CHIP R 470 J 1/8W	M,HK2	R222			RK73GB2A563J	CHIP R 56K J 1/10W	M,HK,HM
R160			RK73FB2B821J	CHIP R 820 J 1/8W	HK,HM	R223			RK73GB2A122J	CHIP R 1.2K J 1/10W	M,HK,HM
R161			RK73GB2A334J	CHIP R 330K J 1/10W	K,K2,HK	R224			RK73GB2A102J	CHIP R 1.0K J 1/10W	M,HK,HM
R161			RK73GB2A334J	CHIP R 330K J 1/10W	HM,HK2	R225			RK73GB2A103J	CHIP R 10K J 1/10W	M,HK,HM
R161			RK73GB2A563J	CHIP R 56K J 1/10W	M	R226			RK73GB2A182J	CHIP R 1.8K J 1/10W	HK,HM
R162			RK73GB2A273J	CHIP R 27K J 1/10W	M	R226			RK73GB2A271J	CHIP R 270 J 1/10W	M
R162			RK73GB2A333J	CHIP R 33K J 1/10W	K,K2,HK	R227			RK73GB2A102J	CHIP R 1.0K J 1/10W	M,HK,HM
R162			RK73GB2A333J	CHIP R 33K J 1/10W	HM,HK2	R229			RK73FB2B000J	CHIP R 0 J 1/8W	M,HK,HM
R163			RK73FB2B000J	CHIP R 0 J 1/8W		R231			RK73GB2A000J	CHIP R 0 J 1/10W	M
R164			RK73RB2H101J	CHIP R 100 J 1/2W	K,K2,HK2	R232			RK73GB2A433J	CHIP R 43K J 1/10W	M
R166			RK73GB2A181J	CHIP R 180 J 1/10W	K,M,K2	R233			RK73GB2A123J	CHIP R 12K J 1/10W	M
R166			RK73GB2A221J	CHIP R 220 J 1/10W	HK,HM,HK2	R234			RK73GB2A104J	CHIP R 100K J 1/10W	M
R167			RK73GB2A000J	CHIP R 0 J 1/10W	K,K2,HK	R235			RK73GB2A333J	CHIP R 33K J 1/10W	M
R167			RK73GB2A000J	CHIP R 0 J 1/10W	HM,HK2	R236			RK73GB2A332J	CHIP R 3.3K J 1/10W	M
R168			RK73GB2A103J	CHIP R 10K J 1/10W	HK,HM	R501			RK73GB2A473J	CHIP R 47K J 1/10W	
R168			RK73GB2A472J	CHIP R 4.7K J 1/10W	M	R502			RK73GB2A472J	CHIP R 4.7K J 1/10W	
R168,169			RK73GB2A103J	CHIP R 10K J 1/10W	K,K2,HK2	R503			RK73GB2A102J	CHIP R 1.0K J 1/10W	
R170			RK73FB2B222J	CHIP R 2.2K J 1/8W	K,K2,HK2	R504-507			RK73GB2A473J	CHIP R 47K J 1/10W	
R171			RK73GB2A153J	CHIP R 15K J 1/10W	K,K2,HK2	R508-510			RK73GB2A000J	CHIP R 0 J 1/10W	



# TK-760G/760HG

## PARTS LIST

TX-RX UNIT (X57-5950-XX)

Ref. No.	Address	New parts	Parts No.	Description	Desti-nation	Ref. No.	Address	New parts	Parts No.	Description	Desti-nation
R511			RK73GB2A473J	CHIP R 47K J 1/10W		R577			RK73GB2A103J	CHIP R 10K J 1/10W	
R512			RK73GB2A104J	CHIP R 100K J 1/10W		R578			RN73GH1J682D	CHIP R 6.8K D 1/16W	
R513			RK73GB2A223J	CHIP R 22K J 1/10W		R579			RK73GB2A223J	CHIP R 22K J 1/10W	
R514			RK73GB2A473J	CHIP R 47K J 1/10W		R580			RK73GB2A000J	CHIP R 0 J 1/10W	
R515,516			RK73GB2A223J	CHIP R 22K J 1/10W		R581			RK73GB2A394J	CHIP R 390K J 1/10W	
R517			RK73GB2A473J	CHIP R 47K J 1/10W		R582			RK73GB2A273J	CHIP R 27K J 1/10W	
R518			RK73GB2A472J	CHIP R 4.7K J 1/10W		R583			RK73GB2A470J	CHIP R 47 J 1/10W	
R519			RK73GB2A103J	CHIP R 10K J 1/10W		R584			RK73GB2A220J	CHIP R 22 J 1/10W	
R520-523			RK73GB2A102J	CHIP R 1.0K J 1/10W		R585			RK73GB2A000J	CHIP R 0 J 1/10W	
R526			RK73GB2A154J	CHIP R 150K J 1/10W		R586			RK73GB2A473J	CHIP R 47K J 1/10W	
R527			RK73GB2A000J	CHIP R 0 J 1/10W	K,K2,HK	R587			RK73GB2A000J	CHIP R 0 J 1/10W	
R527			RK73GB2A000J	CHIP R 0 J 1/10W	HM,HK2	R588			RK73GB2A103J	CHIP R 10K J 1/10W	
R527			RK73GB2A561J	CHIP R 560 J 1/10W	M	R590			RK73GB2A333J	CHIP R 33K J 1/10W	
R528			RK73GB2A472J	CHIP R 4.7K J 1/10W		R591			RK73GB2A000J	CHIP R 0 J 1/10W	
R529			RK73GB2A154J	CHIP R 150K J 1/10W		R592			RK73GB2A103J	CHIP R 10K J 1/10W	
R530			RK73GB2A473J	CHIP R 47K J 1/10W		R593			RK73GB2A181J	CHIP R 180 J 1/10W	
R531			RK73GB2A394J	CHIP R 390K J 1/10W		R594			RK73GB2A392J	CHIP R 3.9K J 1/10W	
R532			RK73GB2A103J	CHIP R 10K J 1/10W		R595			RK73GB2A181J	CHIP R 180 J 1/10W	
R533			RK73GB2A104J	CHIP R 100K J 1/10W		R598			RK73GB2A473J	CHIP R 47K J 1/10W	
R534			RK73GB2A823J	CHIP R 82K J 1/10W		R599,600			RK73GB2A102J	CHIP R 1.0K J 1/10W	
R535			RK73GB2A103J	CHIP R 10K J 1/10W		R602			RK73GB2A473J	CHIP R 47K J 1/10W	
R536			RK73GB2A153J	CHIP R 15K J 1/10W		R603			RK73GB2A101J	CHIP R 100 J 1/10W	
R537			RK73GB2A105J	CHIP R 1.0M J 1/10W		R604			RK73GB2A472J	CHIP R 4.7K J 1/10W	
R538			RK73GB2A103J	CHIP R 10K J 1/10W		R605			RK73GB2A332J	CHIP R 3.3K J 1/10W	
R539			RK73GB2A000J	CHIP R 0 J 1/10W		R606			RK73GB2A102J	CHIP R 1.0K J 1/10W	
R540			RK73GB2A223J	CHIP R 22K J 1/10W		R607			RK73GB2A101J	CHIP R 100 J 1/10W	
R541			RK73GB2A184J	CHIP R 180K J 1/10W		R608			RK73GB2A122J	CHIP R 1.2K J 1/10W	
R542			RK73GB2A102J	CHIP R 1.0K J 1/10W		R610,611			RK73GB2A473J	CHIP R 47K J 1/10W	
R543			RK73GB2A184J	CHIP R 180K J 1/10W		R612			RK73RB2H221J	CHIP R 220 J 1/2W	
R544			RK73GB2A103J	CHIP R 10K J 1/10W		R613			RK73GB2A103J	CHIP R 10K J 1/10W	
R545			RK73GB2A472J	CHIP R 4.7K J 1/10W		R614,615			RK73GB2A000J	CHIP R 0 J 1/10W	
R546			RN73GH1J913D	CHIP R 91K D 1/16W		R616			RK73GB2A474J	CHIP R 470K J 1/10W	
R547			RK73GB2A103J	CHIP R 10K J 1/10W		R617			RK73GB2A472J	CHIP R 4.7K J 1/10W	
R548			RN73GH1J333D	CHIP R 33K D 1/16W		R618			RK73GB2A683J	CHIP R 68K J 1/10W	
R549			RN73GH1J913D	CHIP R 91K D 1/16W		R619			RK73GB2A104J	CHIP R 100K J 1/10W	
R550			RN73GH1J683D	CHIP R 68K D 1/16W		R620,621			RK73GB2A103J	CHIP R 10K J 1/10W	
R551,552			RK73GB2A223J	CHIP R 22K J 1/10W		R622			RK73GB2A473J	CHIP R 47K J 1/10W	
R553			RK73GB2A105J	CHIP R 1.0M J 1/10W		R630			RK73GB2A000J	CHIP R 0 J 1/10W	
R554			RN73GH1J913D	CHIP R 91K D 1/16W		R701			RK73GB2A473J	CHIP R 47K J 1/10W	
R555,556			RK73GB2A104J	CHIP R 100K J 1/10W		R704			RK73GB2A223J	CHIP R 22K J 1/10W	
R557			RN73GH1J274D	CHIP R 270K D 1/16W		R720			RK73GB2A000J	CHIP R 0 J 1/10W	
R558			RK73GB2A000J	CHIP R 0 J 1/10W		R722			RK73GB2A000J	CHIP R 0 J 1/10W	
R559			RK73GB2A333J	CHIP R 33K J 1/10W		D1			DA204U	DIODE	
R560			RK73GB2A474J	CHIP R 470K J 1/10W		D2			02DZ20F-Y,Z	ZENER DIODE	
R561			RK73GB2A333J	CHIP R 33K J 1/10W		D3 -5			DA204U	DIODE	
R562			RK73GB2A000J	CHIP R 0 J 1/10W		D8			DAN235E	DIODE	M
R563			RK73GB2A473J	CHIP R 47K J 1/10W		D8			DAN235K	DIODE	K,K2,HK
R564			RK73GB2A223J	CHIP R 22K J 1/10W		D8			DAN235K	DIODE	HM,HK2
R565			RK73GB2A000J	CHIP R 0 J 1/10W		D9			1SS355	DIODE	M
R566			RK73GB2A563J	CHIP R 56K J 1/10W		D10			DAN235E	DIODE	K,K2,HK
R567			RK73GB2A334J	CHIP R 330K J 1/10W		D10			DAN235K	DIODE	HM,HK2
R568			RK73GB2A473J	CHIP R 47K J 1/10W		D10			DAN235K	DIODE	
R569			RK73GB2A102J	CHIP R 1.0K J 1/10W		D11			MA3J742	DIODE	
R570			RK73GB2A155J	CHIP R 1.5M J 1/10W		D14			1SS355	DIODE	
R571			RN73GH1J682D	CHIP R 6.8K D 1/16W		D15			DAN202K	DIODE	K,K2,HK
R572			RK73GB2A473J	CHIP R 47K J 1/10W		D15			DAN202K	DIODE	HM,HK2
R573			RK73GB2A474J	CHIP R 470K J 1/10W		D15			DAN202U	DIODE	M
R574			RN73GH1J683D	CHIP R 68K D 1/16W		D16			DAN235E	DIODE	M
R575			RK73GB2A101J	CHIP R 100 J 1/10W		D16			DAN235K	DIODE	K,K2,HK
R576			RK73GB2A224J	CHIP R 220K J 1/10W							

K: TK-760G(K) K2: TK-760G(K2) M: TK-760G(M)  
 HK: TK-760HG(K) HK2: TK-760HG(K2) HM: TK-760HG(M)

# TK-760G/760HG

## PARTS LIST

### TX-RX UNIT (X57-5950-XX)

Ref. No.	Address	New parts	Parts No.	Description	Destination	Ref. No.	Address	New parts	Parts No.	Description	Destination
D16			DAN235K	DIODE	HM, HK2	IC400			RA30H1317M131	POWER MODULE	M
D17			1SS355	DIODE		IC400			RA60H13171123	POWER MODULE	HK, HM
D18			HVC350B	VARIABLE CAPACITANCE DIODE	K, K2, HK	IC501			AT29C02090TU	ROM IC	
D18			HVC350B	VARIABLE CAPACITANCE DIODE	HM, HK2	IC502		*	30622MEP524GU	MPU	
D18			1SV305F	VARIABLE CAPACITANCE DIODE	M	IC503			R3111H421C-F	MOS-IC	
D19 ,20			1SS355	DIODE		IC505			AT24C08BN-SH	ROM IC	
D21			02DZ18F-X, Y	ZENER DIODE		IC507			NJM2904V-ZB	MOS-IC	
D22			DA204U	DIODE		IC508			TC35453FG6	MOS-IC	
D23			HVC350B	VARIABLE CAPACITANCE DIODE	K, K2, HK	IC509			BU4066BCFV	MOS-IC	
D23			HVC350B	VARIABLE CAPACITANCE DIODE	HM, HK2	IC510			BU4094BCFV	MOS-IC	
D23			1SV305F	VARIABLE CAPACITANCE DIODE	M	IC511			LC73872M	MOS-IC	
D24			02DZ15F-X, Y	ZENER DIODE		IC512			NJM78L05UA-ZB	BI-POLAR IC	
D25			ZSH5MA27	SURGE ABSORBER	M, HK, HM	IC513			TA75W558FU-F	MOS-IC	
D25			22ZR-10D	SURGE ABSORBER	K, K2, HK2	IC514			TC75W51FUF	MOS-IC	
D26			DSA3A1-FK	DIODE		Q1			DTD114EK	TRANSISTOR	
D27			1SS355	DIODE		Q2			KRA225S	TRANSISTOR	
D28			HVC350B	VARIABLE CAPACITANCE DIODE	K, K2, HK	Q3		*	RT1P141C-T112	TRANSISTOR	
D28			HVC350B	VARIABLE CAPACITANCE DIODE	HM, HK2	Q4 ,5			RT1N141C-T112	TRANSISTOR	K, K2, HK
D28		*	1SV331F	VARIABLE CAPACITANCE DIODE	M	Q4 ,5			RT1N141C-T112	TRANSISTOR	HM, HK2
D30 ,31			HVC350B	VARIABLE CAPACITANCE DIODE	K, K2, HK	Q4 ,5			RT1N141M-T111	TRANSISTOR	M
D30 ,31			HVC350B	VARIABLE CAPACITANCE DIODE	HM, HK2	Q6		*	RT1N241C-T112	TRANSISTOR	K, K2, HK
D30 ,31			1SV305F	VARIABLE CAPACITANCE DIODE	M	Q6		*	RT1N241C-T112	TRANSISTOR	HM, HK2
D33			L709CER-T	DIODE	K, K2	Q6			RT1N241M-T111	TRANSISTOR	M
D34			L709CER-T	DIODE	M	Q7			2SC4649(N,P)	TRANSISTOR	
D34			MA4PH633	DIODE	K, K2, HK	Q8			2SC2412K	TRANSISTOR	
D34			MA4PH633	DIODE	HM, HK2	Q9			2SC4215-F(Y)	TRANSISTOR	
D35 ,36			MA3J742	DIODE		Q10			2SC2412K	TRANSISTOR	
D37			L709CER-T	DIODE	M, HK, HM	Q11			2SA1832(GR)F	TRANSISTOR	
D37			MA4PH633	DIODE	HK2	Q12			2SC4738(GR)F	TRANSISTOR	
D39			UDZW4.7(B)	ZENER DIODE		Q13 ,14			2SC4649(N,P)	TRANSISTOR	
D40			RB706F-40	DIODE		Q15			3SK228	FET	K, K2, HK
D41			HZU5ALL	DIODE		Q15			3SK228	FET	HM, HK2
D42			02DZ5.6F-X, Y	ZENER DIODE	M, HK, HM	Q15			3SK317-E	FET	M
D43			1SS355	DIODE	M, HK, HM	Q16			RT1N141C-T112	TRANSISTOR	K, K2, HK
D44			MA2S111-F	DIODE	M, HK, HM	Q16			RT1N141C-T112	TRANSISTOR	HM, HK2
D501-504			MA2S111-F	DIODE		Q16			RT1N141M-T111	TRANSISTOR	M
D506,507			MA2S111-F	DIODE		Q17			DTC363EK	TRANSISTOR	M
D508			RB706F-40	DIODE		Q17			DTC363EU	TRANSISTOR	K, K2, HK
D523			DAN202U	DIODE		Q17			DTC363EU	TRANSISTOR	HM, HK2
D524,525			DA204U	DIODE		Q18			2SA1745E(6,7)	TRANSISTOR	
D526			1812L075PR	VARISTOR		Q19			RT1N141C-T112	TRANSISTOR	K, K2, HK
D527,528			DA204U	DIODE		Q19			RT1N141C-T112	TRANSISTOR	HM, HK2
D529			RB706F-40	DIODE		Q19			RT1N141M-T111	TRANSISTOR	M
IC1 ,2			TA75S01F-F	MOS-IC		Q20		*	RT1P141C-T112	TRANSISTOR	
IC3			MB15A02PFV2E1	MOS-IC		Q21			RT1N141C-T112	TRANSISTOR	K, K2, HK
IC4			NJM4558M	MOS-IC		Q21			RT1N141C-T112	TRANSISTOR	HM, HK2
IC5			TA31136FNG	MOS-IC		Q21			RT1N141M-T111	TRANSISTOR	M
IC6			M62363FP-F	MOS-IC		Q22			2SC3357-A	TRANSISTOR	
IC7			NJM2904M-ZB	MOS-IC		Q23			2SA1641(S,T)	TRANSISTOR	
IC8			UPB1509GV	BI-POLAR IC		Q24		*	RT1P141C-T112	TRANSISTOR	K, K2, HK
IC9			BU4094BCF	MOS-IC		Q24		*	RT1P141C-T112	TRANSISTOR	HM, HK2
IC10			NJM78L05UA-ZB	BI-POLAR IC		Q24			RT1P141M-T111	TRANSISTOR	M
IC11			AN8009M	MOS-IC		Q25			2SC2954	TRANSISTOR	K, K2, HK2
IC12			KIA7808API	MOS-IC		Q26		*	RT1P141C-T112	TRANSISTOR	
IC13			LA4422-E	BI-POLAR IC		Q27			3SK241(R)	FET	K, K2, HK
IC14			TC4013BF(N)-F	MOS-IC		Q27			3SK241(R)	FET	HM, HK2
IC15			TA75S01F-F	MOS-IC		Q27			3SK317-E	FET	M
IC400			M67741H-32	POWER MODULE	K	Q28			2SB1132(Q,R)	TRANSISTOR	
IC400			M67741L-35	POWER MODULE	K2	Q29			RT1N141C-T112	TRANSISTOR	K, K2, HK
IC400			M68702L	POWER MODULE	HK2	Q29			RT1N141C-T112	TRANSISTOR	HM, HK2

# TK-760G/760HG

## PARTS LIST

TX-RX UNIT (X57-5950-XX)  
VCO UNIT (X58-4670-XX)

Ref. No.	Address	New parts	Parts No.	Description	Desti-nation	Ref. No.	Address	New parts	Parts No.	Description	Desti-nation
Q29			RT1N141M-T111	TRANSISTOR	M	CN101			E40-6019-05	PIN ASSY	
Q31			2SC2412K	TRANSISTOR	K,K2,HK2	-			F10-2279-04	SHIELDING CASE	
Q32			2SB1565(E,F)	TRANSISTOR	K,K2,HK2						
Q33			RT1N141C-T112	TRANSISTOR	K,K2,HK						
Q33			RT1N141C-T112	TRANSISTOR	HM,HK2	L101-104			L41-1595-33	SMALL FIXED INDUCTOR(1.5UH)	
Q33			RT1N141M-T111	TRANSISTOR	M	L105			L41-3975-33	SMALL FIXED INDUCTOR(0.039UH)	
Q35		*	RT1N441C-T112	TRANSISTOR	K,K2,HK	L106		*	L41-2775-33	SMALL FIXED INDUCTOR(0.027UH)	
Q35		*	RT1N441C-T112	TRANSISTOR	HM,HK2	L107,108			L41-1098-40	SMALL FIXED INDUCTOR(1000NH)	
Q35			RT1N441M-T111	TRANSISTOR	M	L109,110			L41-1595-33	SMALL FIXED INDUCTOR(1.5UH)	
Q36			2SC2412K	TRANSISTOR		L111			L34-4547-05	AIR-CORE COIL(4.5T)	K,M,HK
Q37,38			2SK1824-A	FET		L111			L34-4547-05	AIR-CORE COIL(4.5T)	HM
Q39			2SC4116(Y)F	TRANSISTOR	M,HK,HM	L112			L34-4548-05	AIR-CORE COIL(5.5T)	K2,HK2
Q501			2SC4619	TRANSISTOR		L116			L34-4549-05	AIR-CORE COIL(6.5T)	
Q502,503			RT1N141U-T111	TRANSISTOR		R101,102			RK73GB2A101J	CHIP R 100 J 1/10W	
Q504			2SC4617(S)	TRANSISTOR		R103			RK73GB2A102J	CHIP R 1.0K J 1/10W	
Q505			2SB1132(Q,R)	TRANSISTOR		R104			RK73GB2A470J	CHIP R 47 J 1/10W	
Q506			RT1N141U-T111	TRANSISTOR		R105			RK73GB2A154J	CHIP R 150K J 1/10W	
Q508			2SC4617(S)	TRANSISTOR		R106			RK73GB2A470J	CHIP R 47 J 1/10W	
Q509			DTC363EU	TRANSISTOR		R107-110			RK73GB2A103J	CHIP R 10K J 1/10W	
TH1			157-153-65001	THERMISTOR		R111			RK73GB2A331J	CHIP R 330 J 1/10W	
						R112,113			RK73GB2A181J	CHIP R 180 J 1/10W	
						R114			RK73GB2A470J	CHIP R 47 J 1/10W	
						R115			RK73GB2A103J	CHIP R 10K J 1/10W	
						R116			RK73GB2A392J	CHIP R 3.9K J 1/10W	
						R117			RK73GB2A101J	CHIP R 100 J 1/10W	
						D101-104			1SV283F	VARIABLE CAPACITANCE DIODE	
						D105			HVU363A	DIODE	
						Q101			2SK508NV(52K)	FET	
						Q102			DTC114EUA	TRANSISTOR	
						Q103			2SK508NV(52K)	FET	
						Q104,105			2SC4081	TRANSISTOR	
						Q106			2SC4226-A(R24)	TRANSISTOR	
<b>VCO UNIT (X58-4670-XX) -10: K,M,HK,HM -11: K2,HK2</b>											
C102			CK73GB1H471K	CHIP C 470PF K							
C104			CC73GCH1H150J	CHIP C 15PF J	K2,HK2						
C104,105			CC73GCH1H150J	CHIP C 15PF J	K,M,HK						
C104,105			CC73GCH1H150J	CHIP C 15PF J	HM						
C105			CC73GCH1H270J	CHIP C 27PF J	K2,HK2						
C107			CC73GCH1H060D	CHIP C 6.0PF D	K2,HK2						
C107			CC73GCH1H080D	CHIP C 8.0PF D	K,M,HK						
C107			CC73GCH1H080D	CHIP C 8.0PF D	HM						
C110			CC73GCH1H040B	CHIP C 4.0PF B	K,M,HK						
C110			CC73GCH1H040B	CHIP C 4.0PF B	HM						
C110			CC73GCH1H120J	CHIP C 12PF J	K2,HK2						
C111			CC73GCH1H040B	CHIP C 4.0PF B	K2,HK2						
C111			CC73GCH1H050B	CHIP C 5.0PF B	K,M,HK						
C111			CC73GCH1H050B	CHIP C 5.0PF B	HM						
C112,113			CC73GCH1H020B	CHIP C 2.0PF B							
C114			CC73GCH1H070D	CHIP C 7.0PF D	K2,HK2						
C114,115			CC73GCH1H060D	CHIP C 6.0PF D	K,M,HK						
C114,115			CC73GCH1H060D	CHIP C 6.0PF D	HM						
C115			CC73GCH1H050B	CHIP C 5.0PF B	K2,HK2						
C116			CC73GCH1H120J	CHIP C 12PF J							
C117			CK73GB1H471K	CHIP C 470PF K							
C118			CC73GCH1H050B	CHIP C 5.0PF B							
C119,120			CK73GB1H471K	CHIP C 470PF K							
C121			CC73GCH1H090D	CHIP C 9.0PF D							
C122			CC73GCH1H0R5B	CHIP C 0.5PF B							
C123			CK73GB1H471K	CHIP C 470PF K							
C124			CC73GCH1H0R5B	CHIP C 0.5PF B							
C125			CK73GB1H102K	CHIP C 1000PF K							
C126			CK73GB1H471K	CHIP C 470PF K							
C127			CC73GCH1H100D	CHIP C 10PF D							
TC106			C05-0384-05	CERAMIC TRIMMER CAPACITOR(10P)							
TC109			C05-0384-05	CERAMIC TRIMMER CAPACITOR(10P)							

K: TK-760G(K) K2: TK-760G(K2) M: TK-760G(M)  
HK: TK-760HG(K) HK2: TK-760HG(K2) HM: TK-760HG(M)

# TK-760G/760HG PC BOARD

DISPLAY UNIT (X54-3270-10)  
Component side view (J72-0683-12)

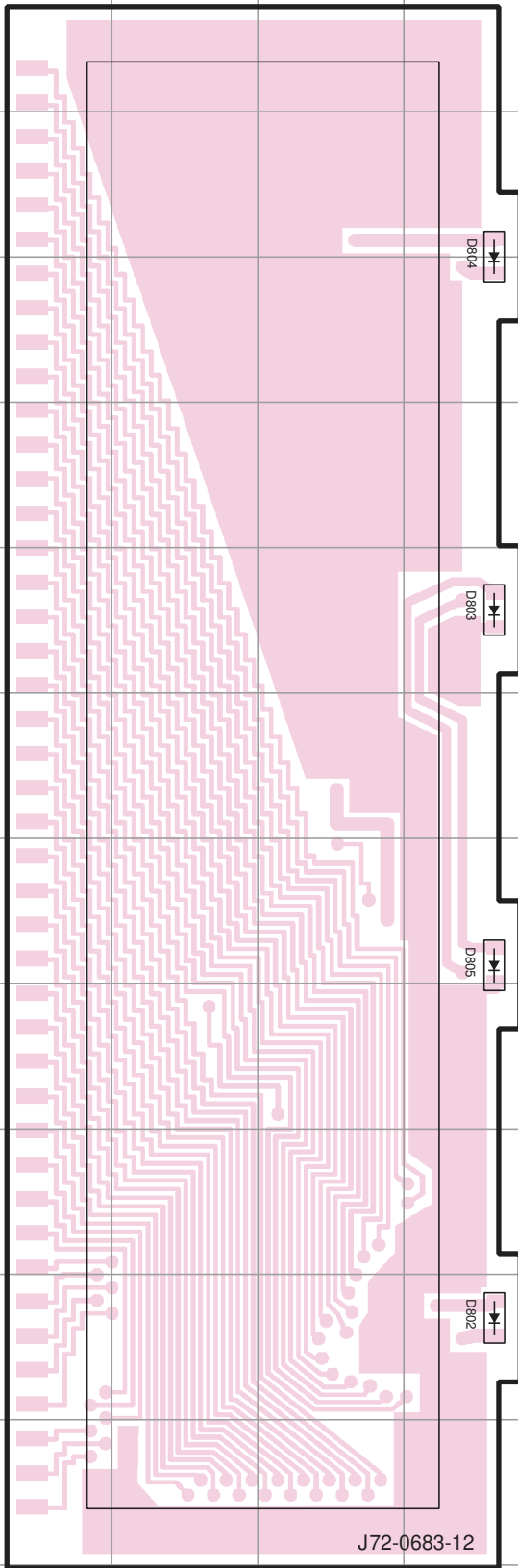

Ref. No.	Address
D802	11E
D803	6E
D804	3E
D805	8E

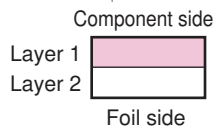

DISPLAY UNIT (X54-3270-10)  
Foil side view (J72-0683-12)

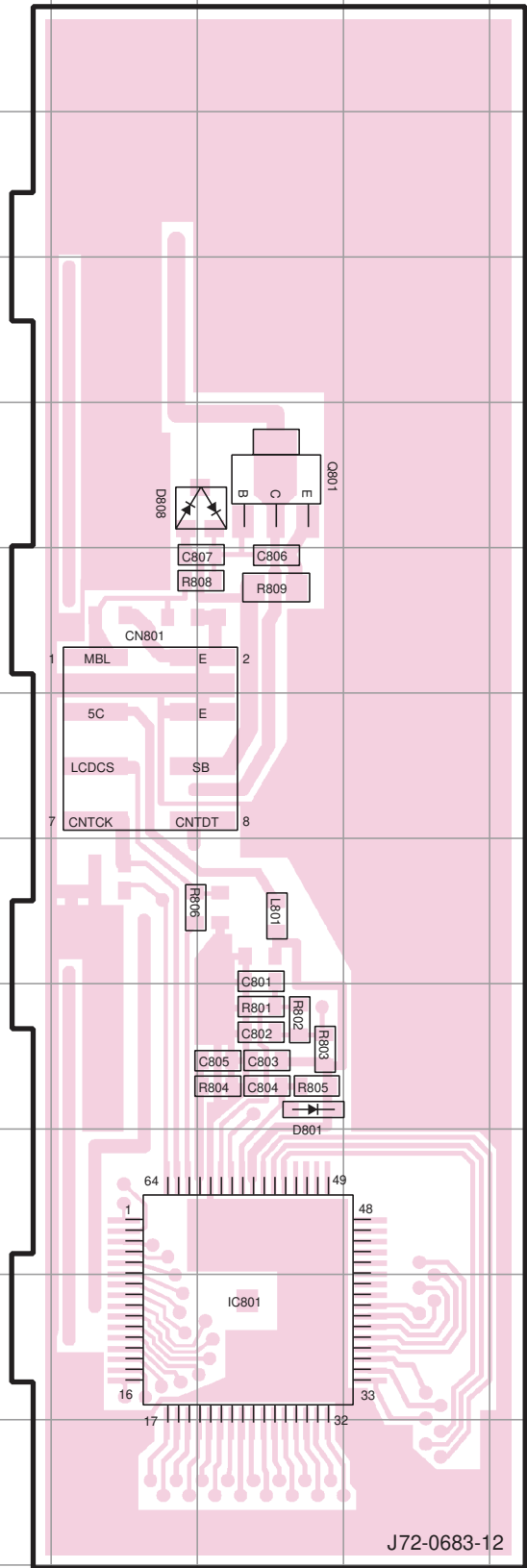

Ref. No.	Address
IC801	11H
Q801	5H
D801	9H
D808	5G

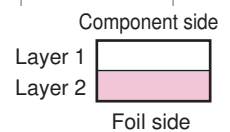

# PC BOARD TK-760G/760HG

VCO UNIT (X58-4670-XX) -10: TK-760G/760HG(K,M) -11: TK-760G/760HG(K2)  
Component side view (J72-0676-02)

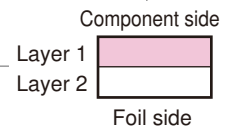
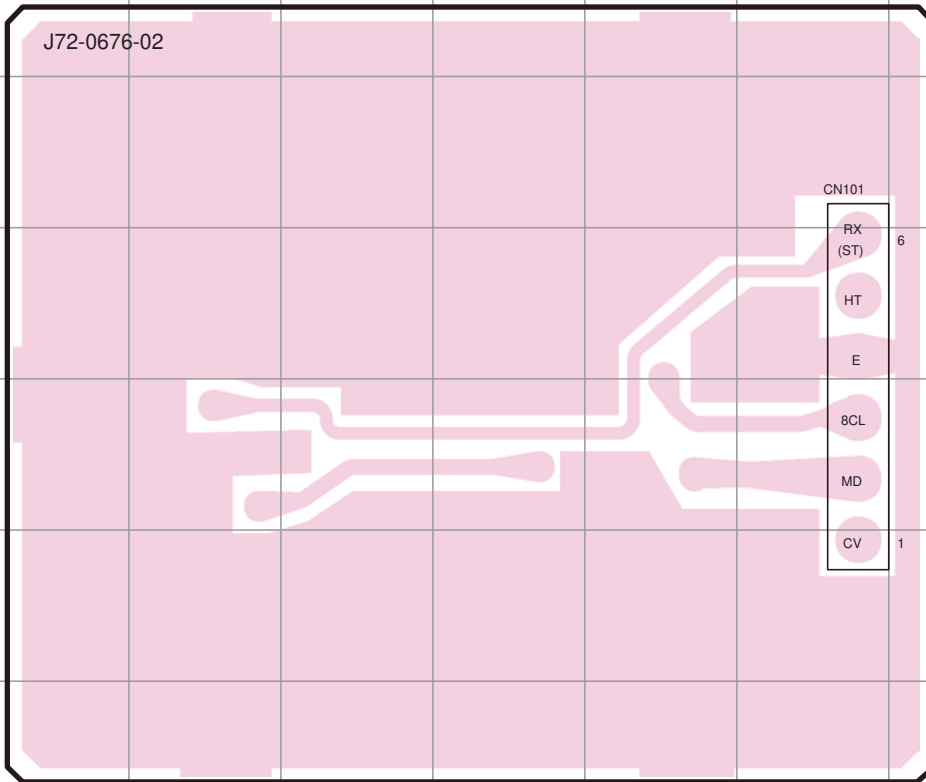

VCO UNIT (X58-4670-XX) -10: TK-760G/760HG(K,M) -11: TK-760G/760HG(K2)  
Foil side view (J72-0676-02)

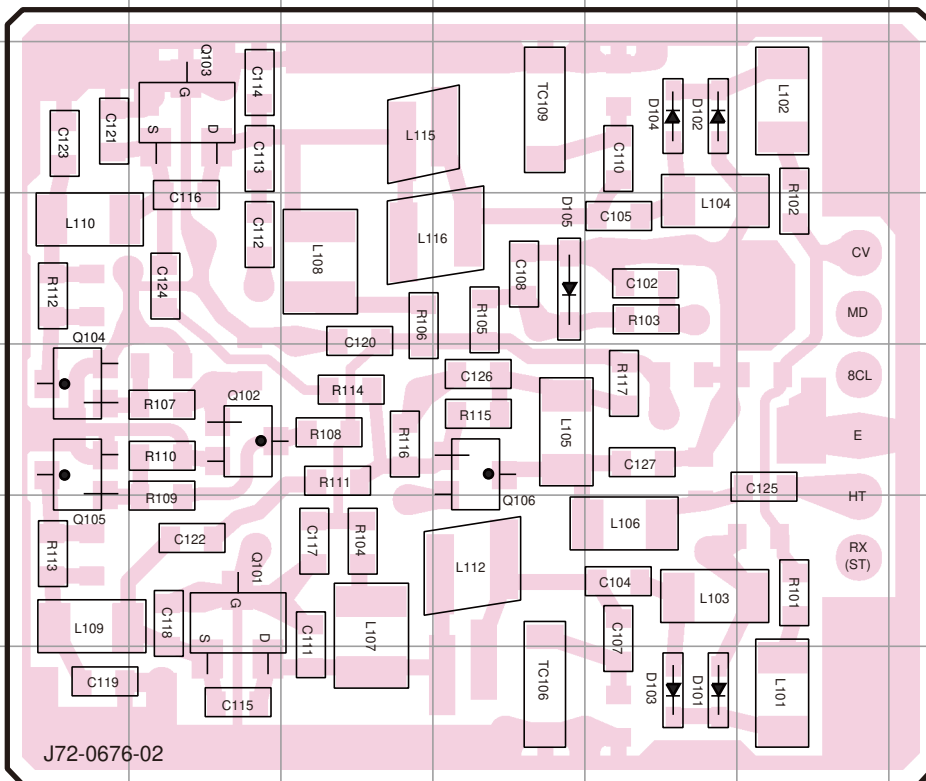

Ref. No.	Address
Q101	12C
Q102	11C
Q103	9C
Q104	11B
Q105	11B
Q106	11E
D101	13F
D102	9F
D103	13F
D104	9F
D105	10E

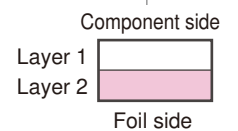

# TK-760G/760HG PC BOARD

TX-RX UNIT (X57-5950-XX) (A/2) -10: TK-760G(K) -12: TK-760G(K2) -16: TK-760HG(K2)

Component side view (J72-0759-12)

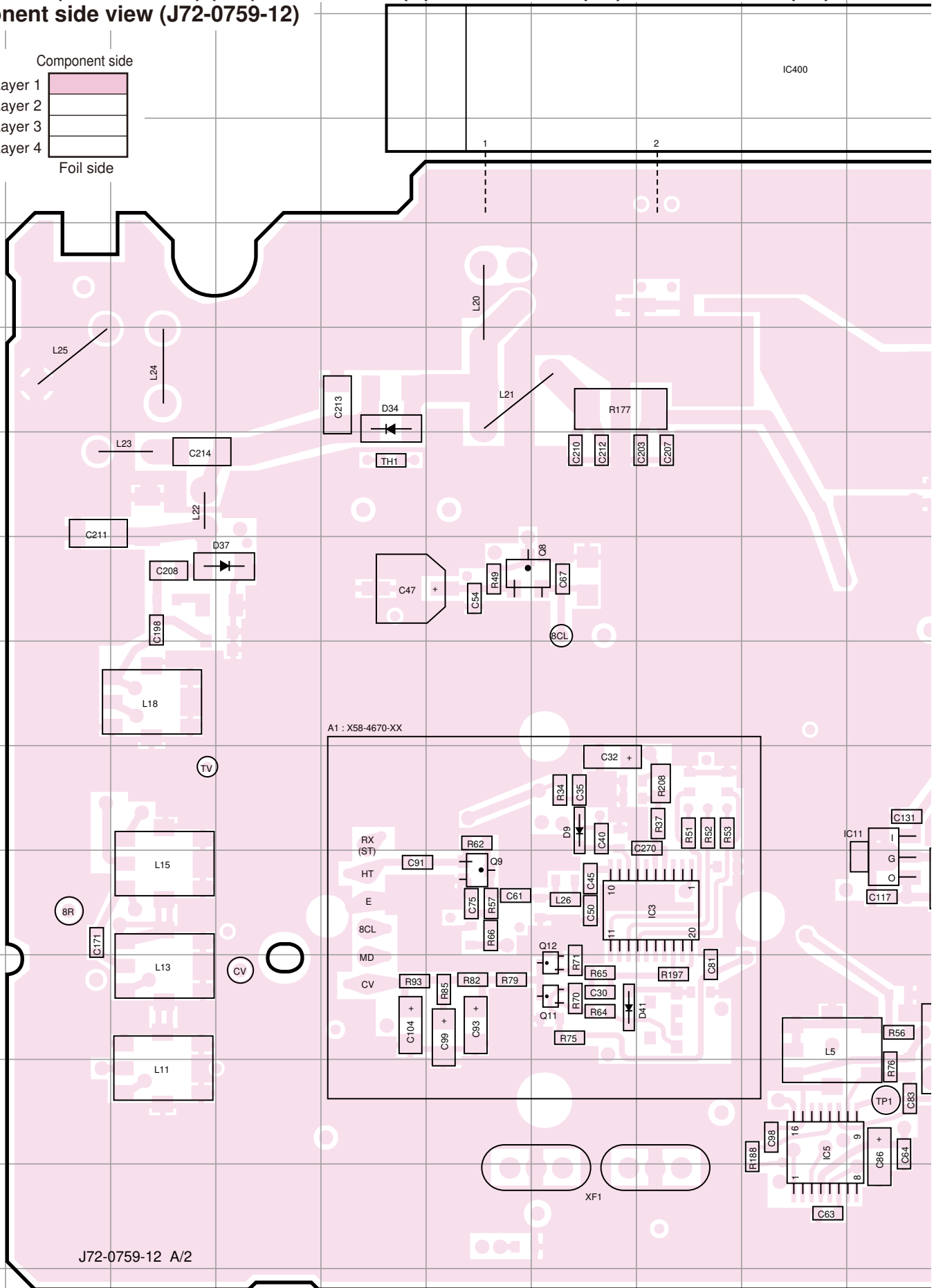
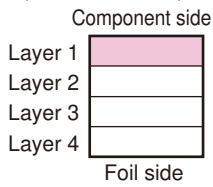

# PC BOARD TK-760G/760HG

TX-RX UNIT (X57-5950-XX)(A/2) -10: TK-760G(K) -12: TK-760G(K2) -16: TK-760HG(K2)

Component side view (J72-0759-12)

Ref. No.	Address	Ref. No.	Address	Ref. No.	Address	Ref. No.	Address
IC3	10H	IC13	8R	Q32	4O	D34	5E
IC4	12M	IC400	2I	Q35	12L	D37	7D
IC5	12I	Q2	12R	Q37	11L	D40	11M
IC6	10M	Q8	7G	Q38	12R	D41	11G
IC7	9L	Q9	10F	D9	9G		
IC11	10J	Q11	11G	D25	5O		
IC12	6O	Q12	11G	D26	4L		

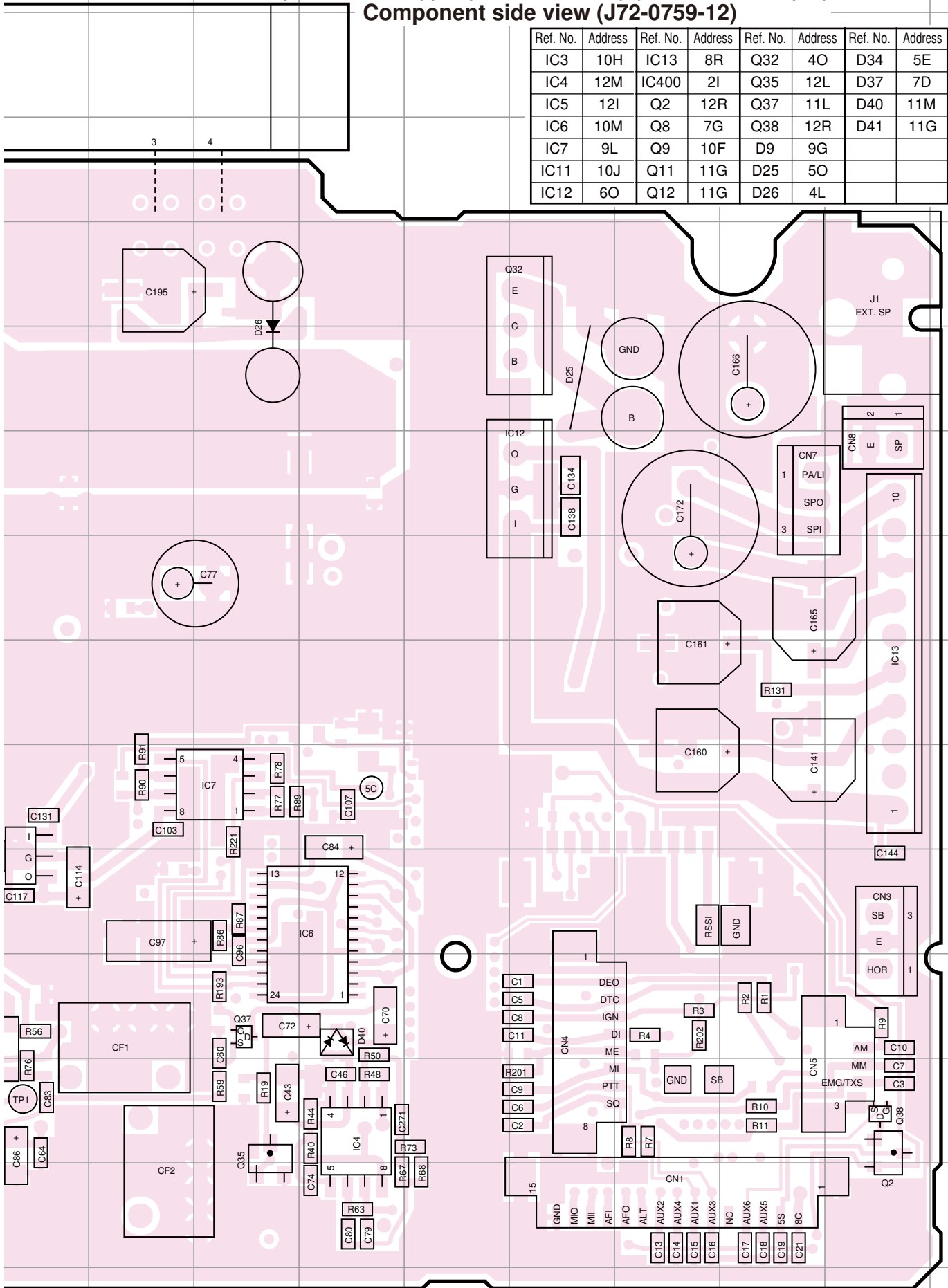

# TK-760G/760HG PC BOARD

TX-RX UNIT (X57-5950-XX) (A/2) -10: TK-760G(K) -12: TK-760G(K2) -16: TK-760HG(K2)

Foil side view (J72-0759-12)

Ref. No.	Address	Ref. No.	Address	Ref. No.	Address	Ref. No.	Address	Ref. No.	Address	Ref. No.	Address	Ref. No.	Address	Ref. No.	Address
IC1	11E	IC15	7O	Q6	11B	Q16	13M	Q22	7L	Q28	7I	D2	12B	D11	12G
IC2	9J	IC400	2K	Q7	11K	Q17	9B	Q23	7E	Q29	7G	D3	13C	D14	10H
IC8	9N	Q1	11B	Q10	13G	Q18	13N	Q24	8B	Q31	6H	D4	13C	D15	10B
IC9	9G	Q3	12H	Q13	13K	Q19	7C	Q25	6J	Q33	7N	D5	13D	D16	11N
IC10	8E	Q4	12H	Q14	10N	Q20	8C	Q26	8C	Q36	9K	D8	12J	D17	7L
IC14	9D	Q5	11B	Q15	13O	Q21	7C	Q27	9Q	D1	13D	D10	13I	D18	12Q

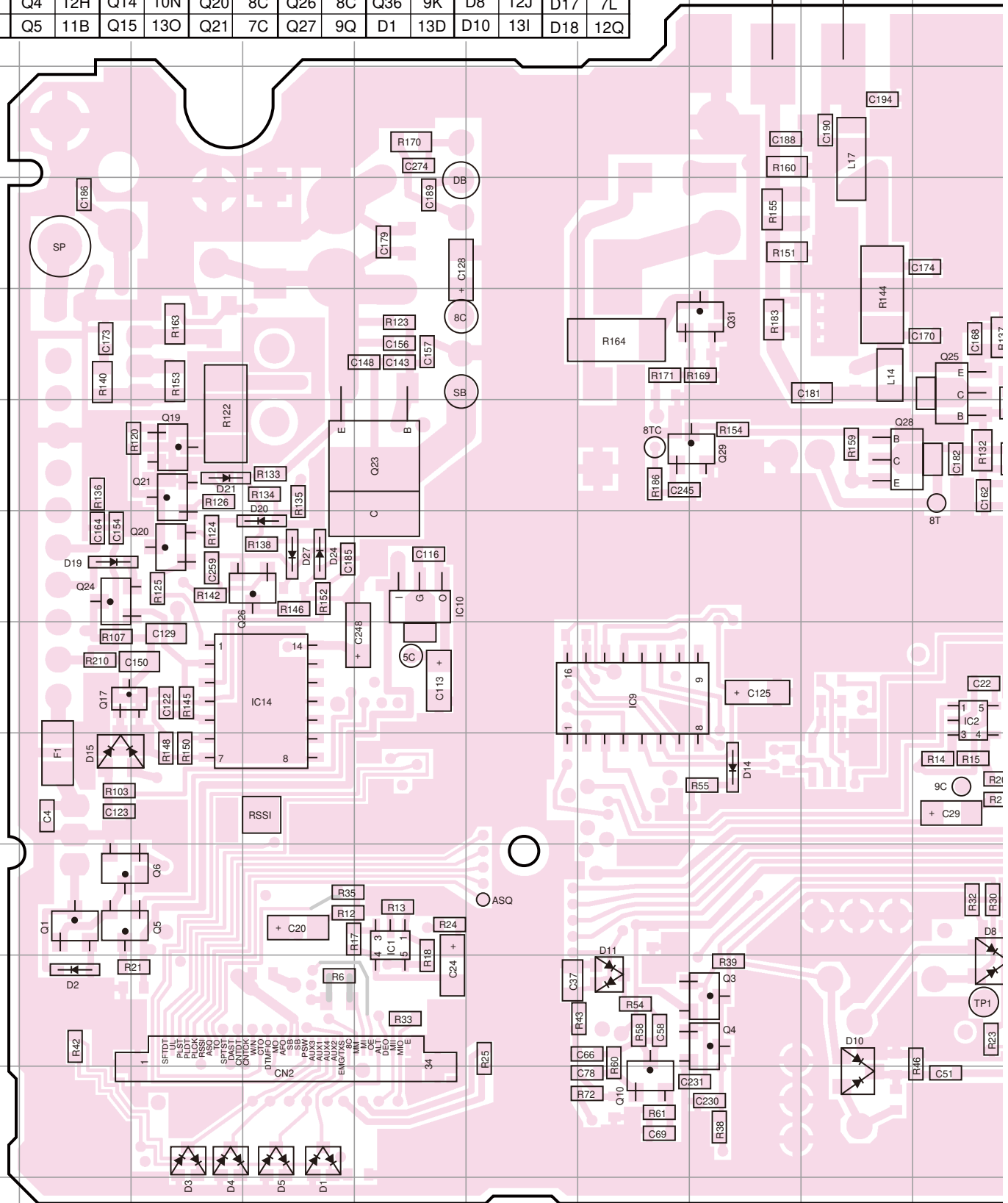



# PC BOARD TK-760G/760HG

TX-RX UNIT (X57-5950-XX) (A/2) -10: TK-760G(K) -12: TK-760G(K2) -16: TK-760HG(K2)

Foil side view (J72-0759-12)

Ref. No.	Address	Ref. No.	Address	Ref. No.	Address
D19	8B	D27	8D	D39	8L
D20	8D	D28	10Q		
D21	7C	D30	8Q		
D22	7J	D31	8Q		
D23	10Q	D35	7Q		
D24	8D	D36	6R		

Component side

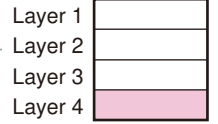

Foil side

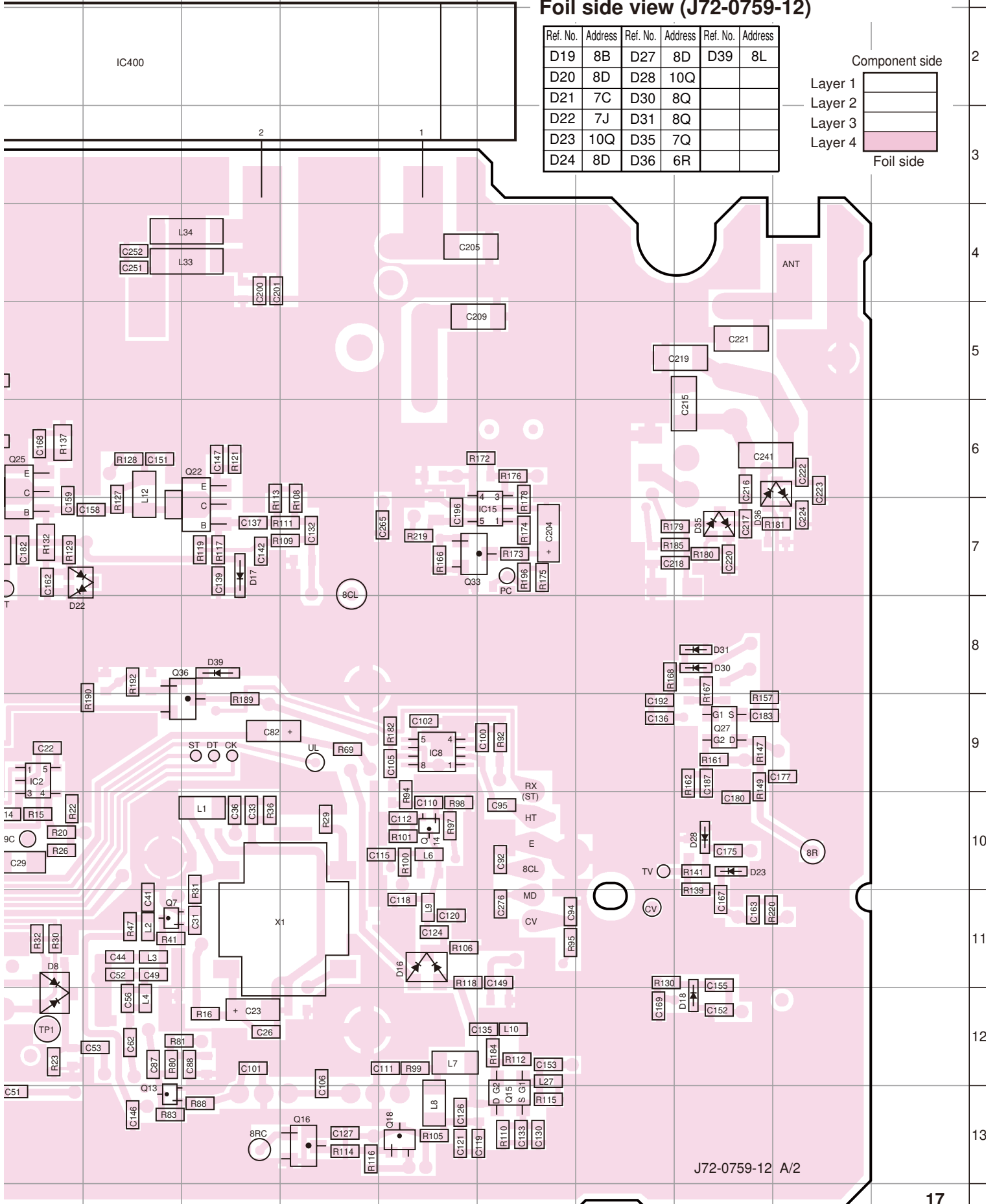

J72-0759-12 A/2

# TK-760G/760GH PC BOARD

TX-RX UNIT (X57-5950-XX) (B/2) -10: TK-760G(K) -12: TK-760G(K2) -16: TK-760HG(K2)  
Component side view (J72-0759-12)

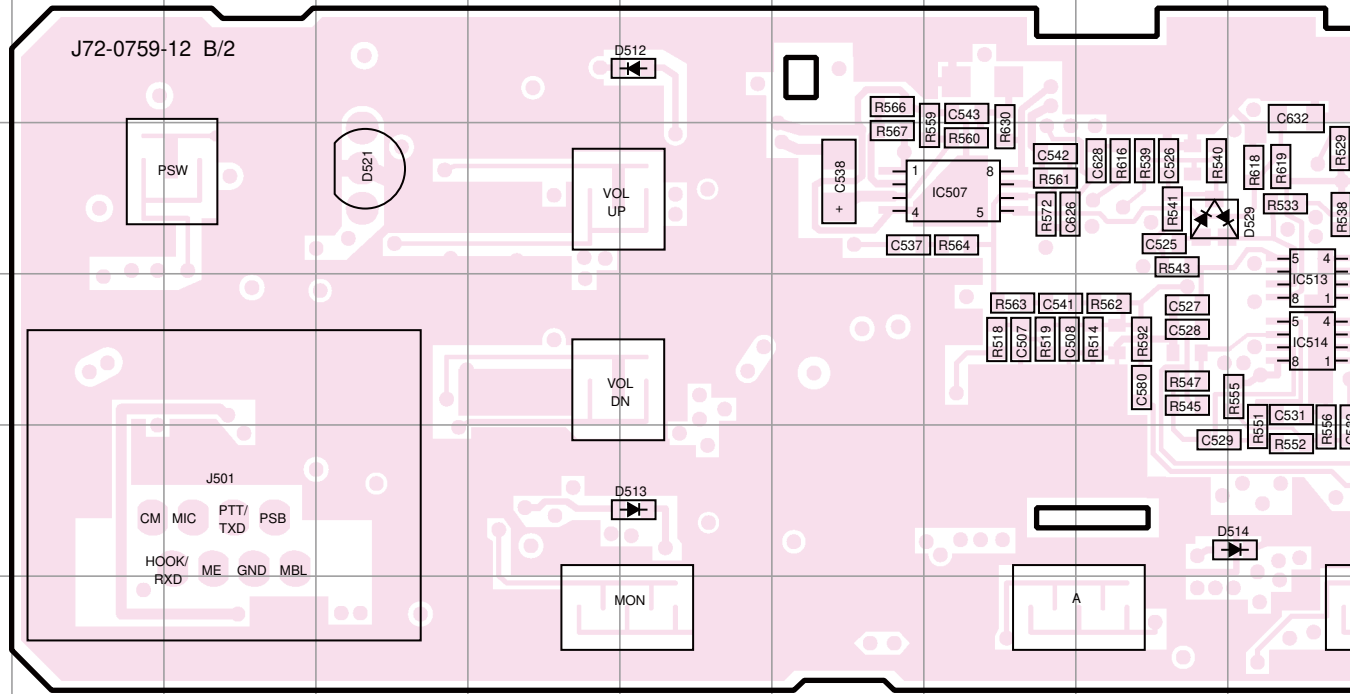

Ref. No.	Address	Ref. No.	Address	Ref. No.	Address	Ref. No.	Address	Ref. No.	Address
IC501	3P	IC510	3M	D506	4L	D511	2R	D514	5J
IC503	4L	IC513	3J	D509	5N	D512	2F	D521	3D
IC507	3H	IC514	4J	D510	5R	D513	5F	D529	3I

TX-RX UNIT (X57-5950-XX) (B/2) -10: TK-760G(K) -12: TK-760G(K2) -16: TK-760HG(K2)  
Foil side view (J72-0759-12)

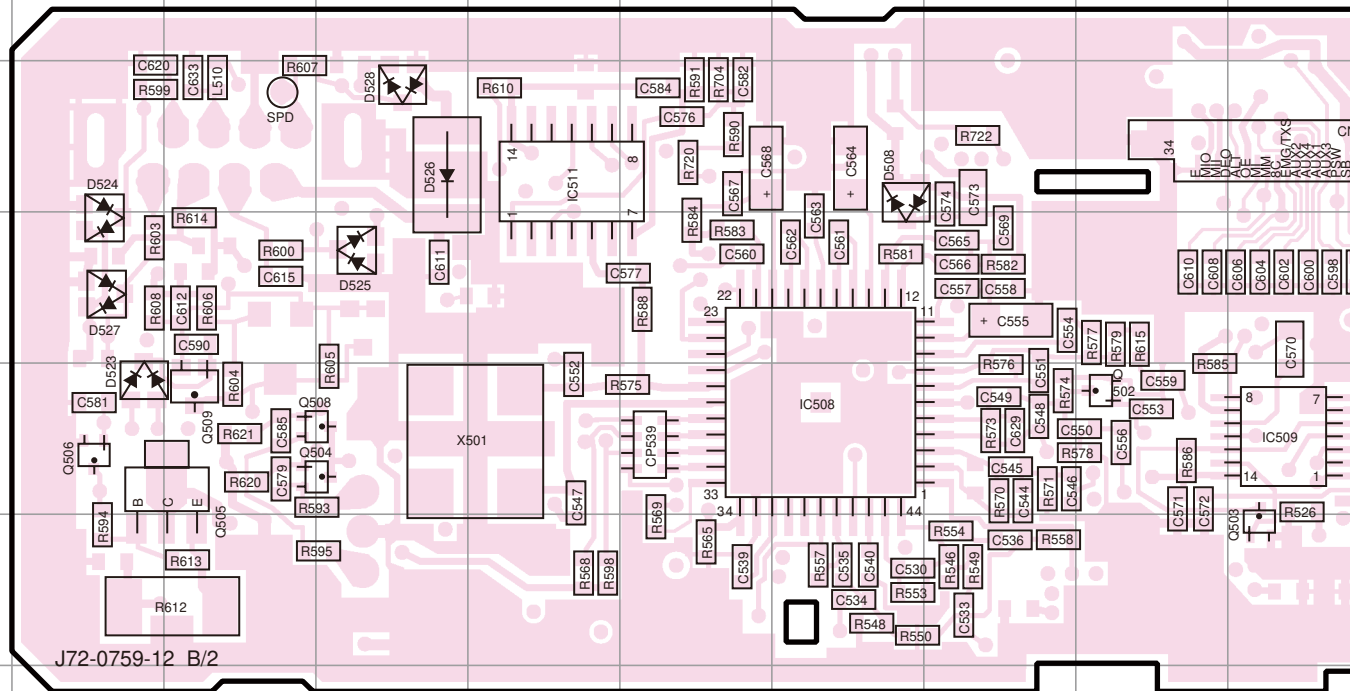

Ref. No.	Address	Ref. No.	Address	Ref. No.	Address	Ref. No.	Address	Ref. No.	Address	Ref. No.	Address	Ref. No.	Address	Ref. No.	Address
IC502	10Q	IC509	11J	Q501	9S	Q504	11C	Q508	11C	D502	11O	D505	11O	D523	11B
IC505	12O	IC511	9E	Q502	11I	Q505	11B	Q509	11C	D503	10O	D507	11N	D524	11B
IC508	11G	IC512	11L	Q503	12H	Q506	11B	D501	11O	D504	11O	D508	9G	D525	10D
														D526	9D
														D527	10B
														D528	9D



# TK-760G/760HG PC BOARD

TX-RX UNIT (X57-5950-14) (A/2): TK-760HG(K,M)

Component side view (J72-0992-09)

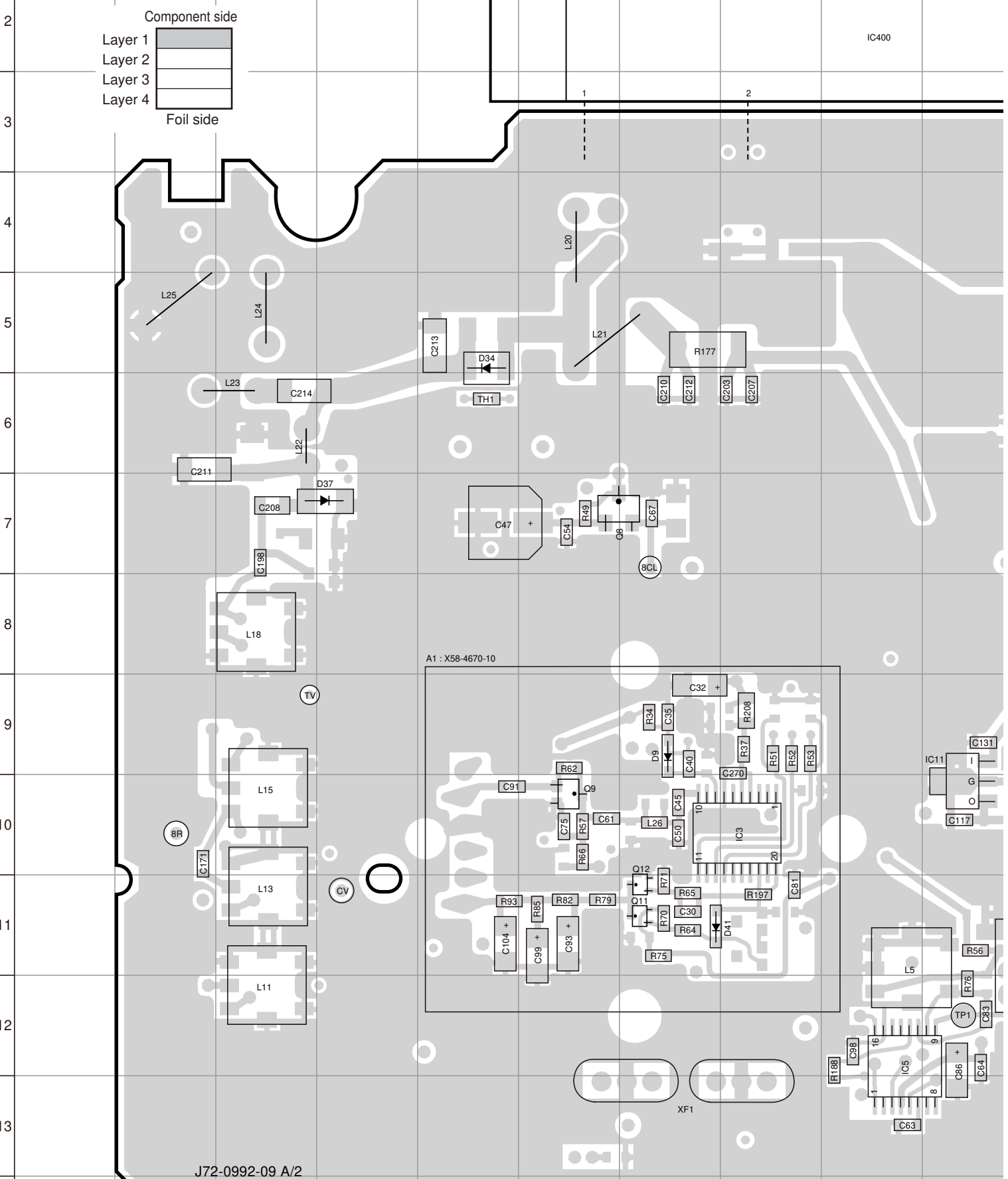
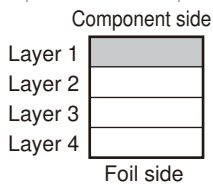

# PC BOARD TK-760G/760HG

TX-RX UNIT (X57-5950-14)(A/2) : TK-760HG(K,M)  
Component side view (J72-0992-09)

Ref. No.	Address	Ref. No.	Address	Ref. No.	Address	Ref. No.	Address
IC3	10H	IC12	6O	Q11	11G	D25	4M
IC4	12M	IC13	8R	Q12	11G	D26	4O
IC5	12I	IC400	2I	Q35	12L	D34	5E
IC6	10M	Q2	12R	Q37	11L	D37	7D
IC7	9L	Q8	7F	Q38	12R	D40	11M
IC11	10J	Q9	10F	D9	9G	D41	11G

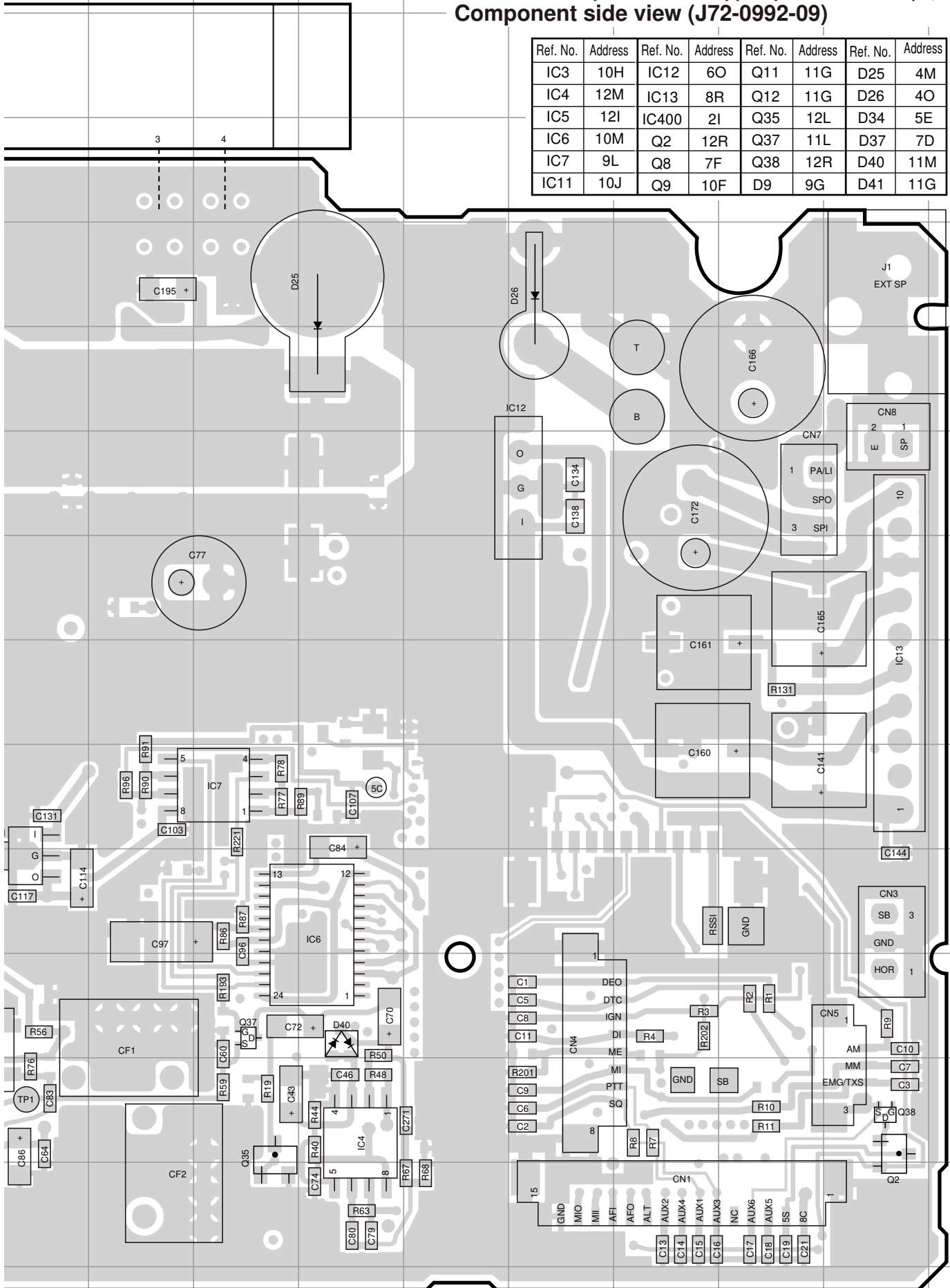

# TK-760G/760HG PC BOARD

TX-RX UNIT (X57-5950-14) (A/2) : TK-760HG(K,M)

Foil side view (J72-0992-09)

Ref. No.	Address	Ref. No.	Address	Ref. No.	Address	Ref. No.	Address	Ref. No.	Address	Ref. No.	Address	Ref. No.	Address	Ref. No.	Address
IC1	11E	IC15	7O	Q6	11B	Q16	13M	Q22	7L	Q29	7G	D3	13C	D14	10H
IC2	9J	IC400	2K	Q7	11K	Q17	9B	Q23	7E	Q33	7N	D4	13C	D15	10B
IC8	9N	Q1	11B	Q10	13G	Q18	13N	Q24	8B	Q36	9K	D5	13D	D16	11N
IC9	9G	Q3	12H	Q13	13K	Q19	7C	Q26	8D	Q39	5G	D8	12J	D17	7L
IC10	8E	Q4	12H	Q14	10N	Q20	8C	Q27	9Q	D1	13D	D10	13I	D18	12Q
IC14	9D	Q5	11B	Q15	13O	Q21	7C	Q28	7I	D2	12B	D11	12G	D19	8B

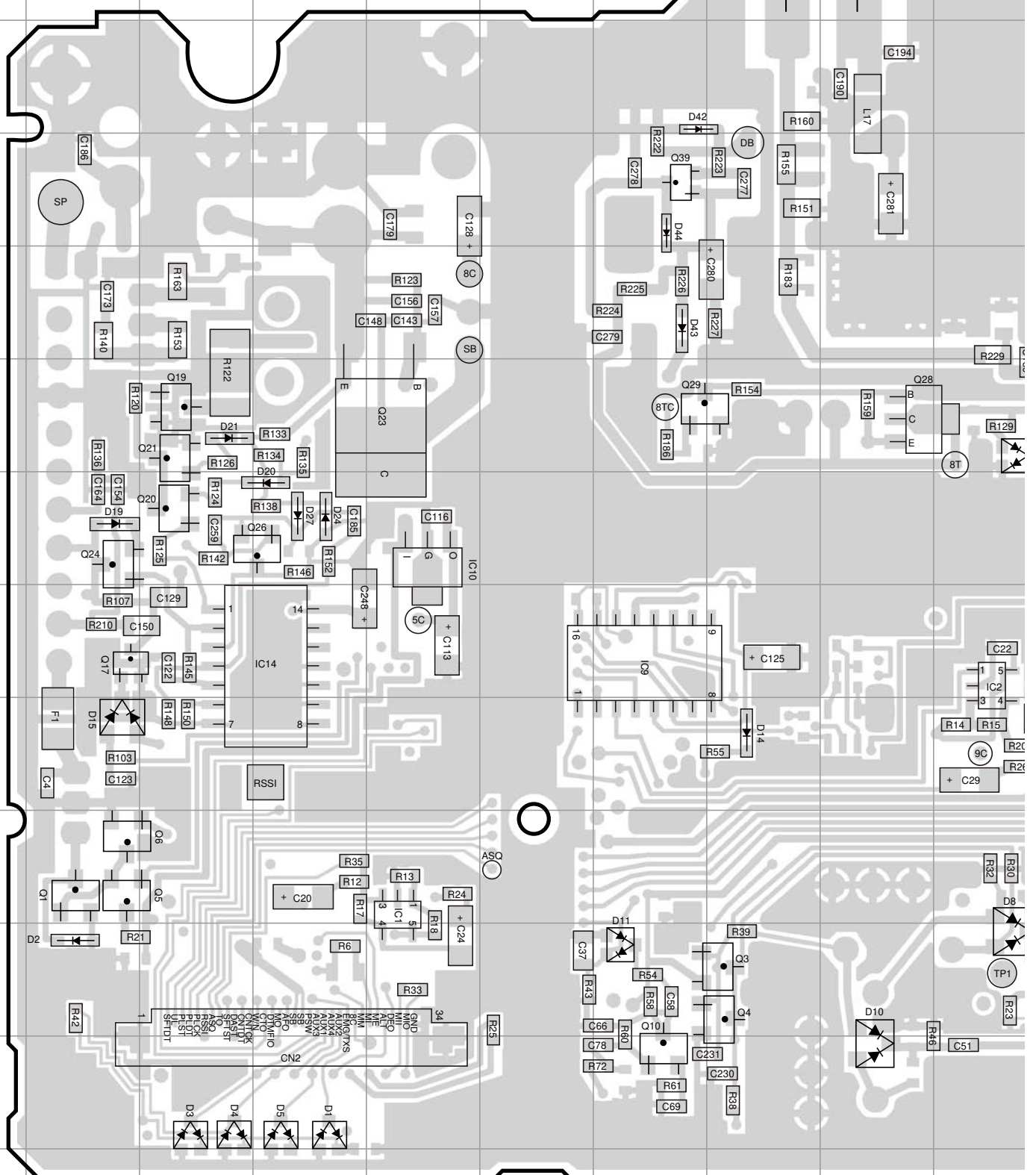

# PC BOARD TK-760G/760HG

TX-RX UNIT (X57-5950-14) (A/2) : TK-760HG(K,M)

Foil side view (J72-0992-09)

Ref. No.	Address	Ref. No.	Address	Ref. No.	Address
D20	8D	D28	10Q	D42	4G
D21	7C	D30	8Q	D43	6G
D22	7J	D31	8Q	D44	5G
D23	10Q	D35	7Q		
D24	8D	D36	6R		
D27	8D	D39	8L		

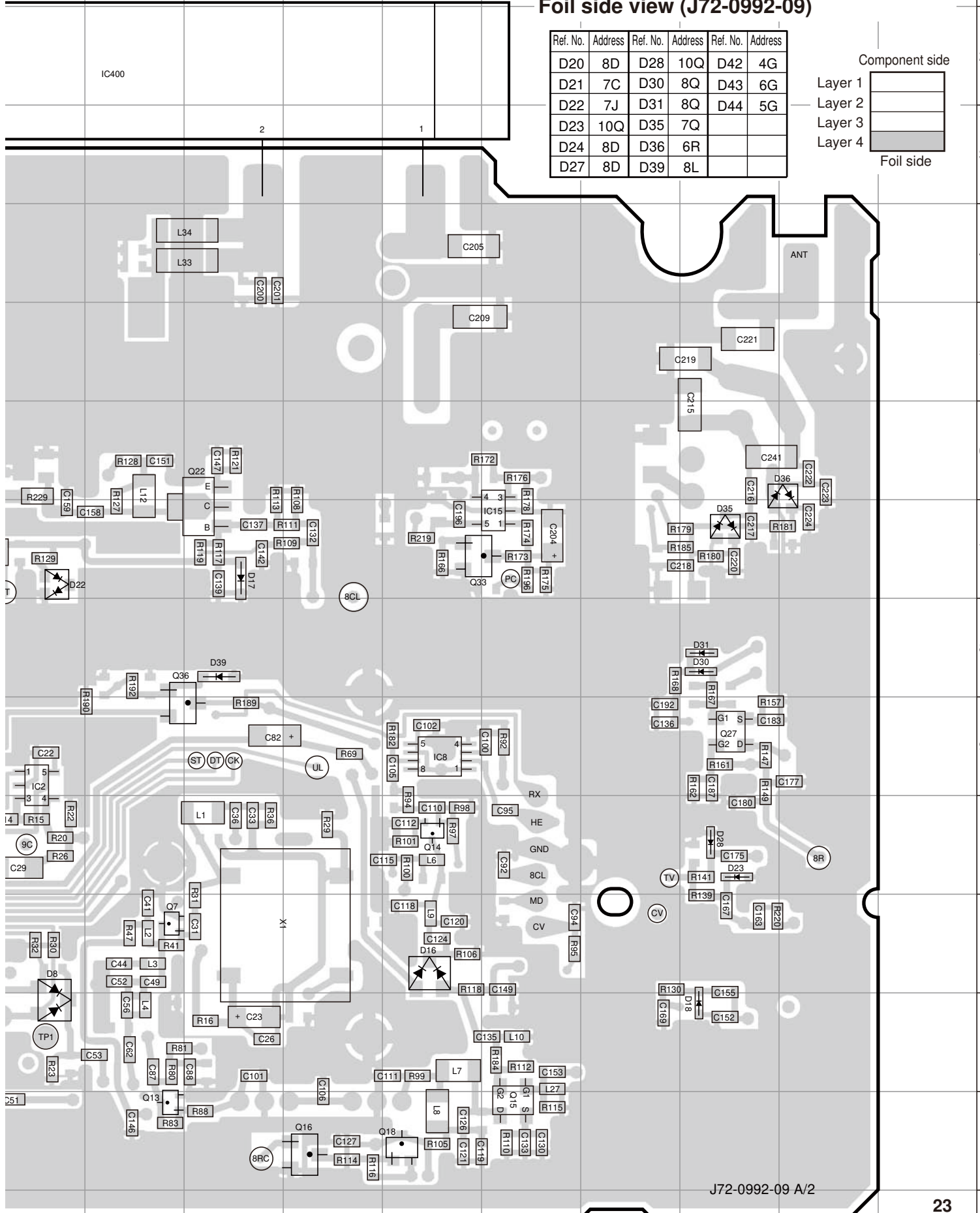
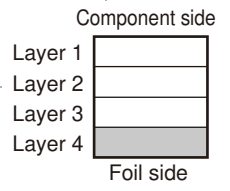

J72-0992-09 A/2

# TK-760G/760HG PC BOARD

TX-RX UNIT (X57-5950-14) (B/2) : TK-760HG(K,M)

Component side view (J72-0992-09)

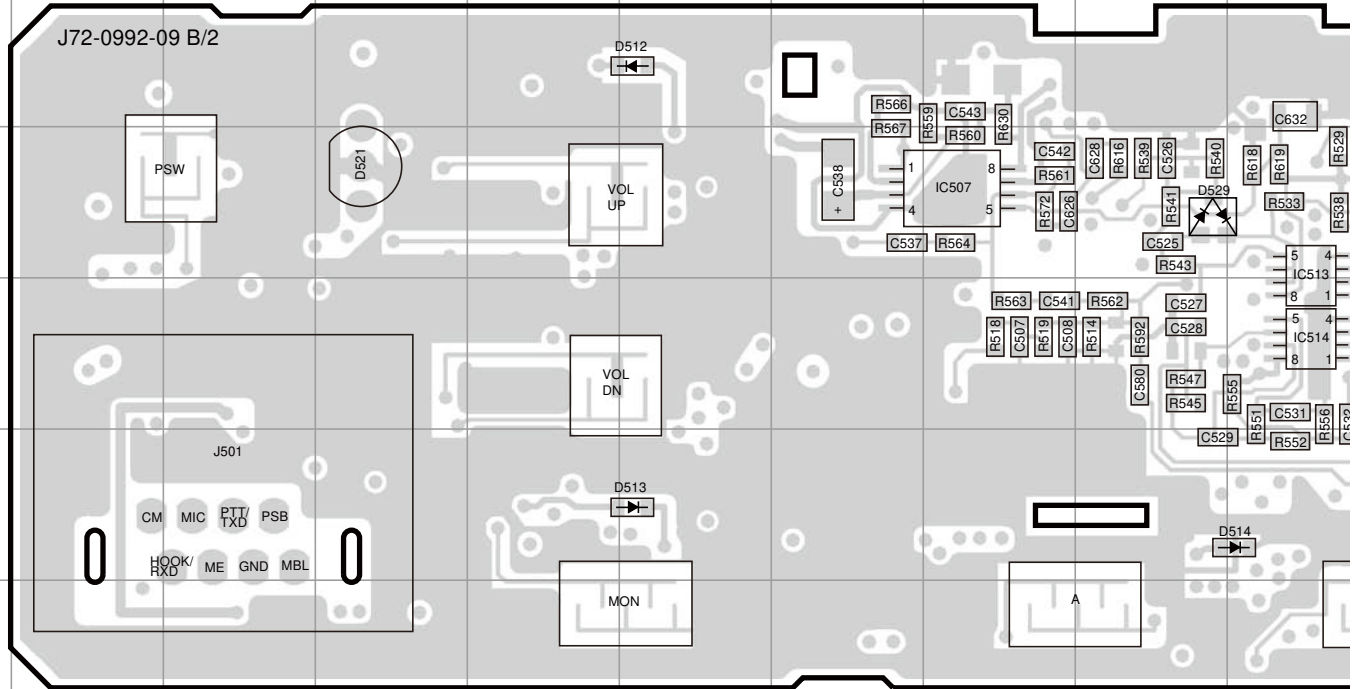

Ref. No.	Address	Ref. No.	Address	Ref. No.	Address	Ref. No.	Address	Ref. No.	Address
IC501	3P	IC510	3M	D506	4L	D511	2R	D514	5J
IC503	4L	IC513	3J	D509	5N	D512	2F	D521	2D
IC507	3H	IC514	4J	D510	5R	D513	5F	D529	3I

TX-RX UNIT (X57-5950-14) (B/2) : TK-760HG(K,M)

Foil side view (J72-0992-09)

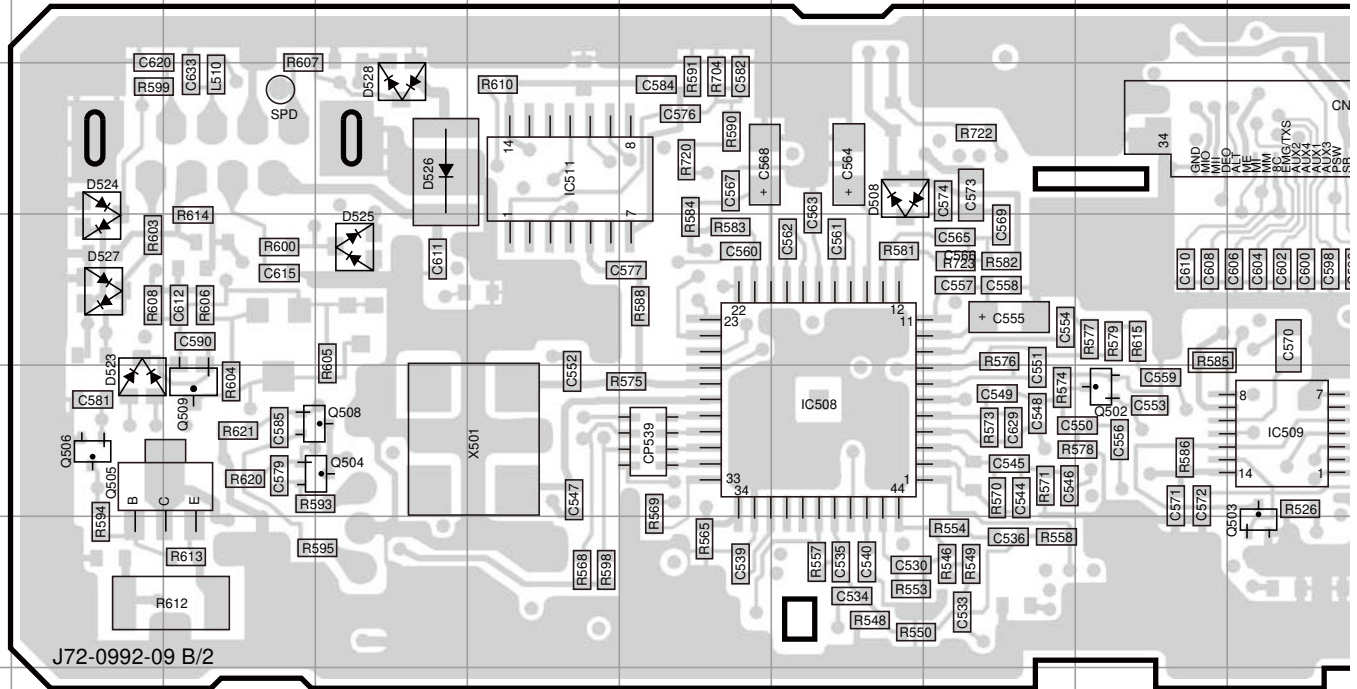

Ref. No.	Address	Ref. No.	Address	Ref. No.	Address	Ref. No.	Address	Ref. No.	Address	Ref. No.	Address	Ref. No.	Address	Ref. No.	Address
IC502	10Q	IC509	11J	Q501	9S	Q504	11C	Q508	11C	D502	11O	D505	11O	D523	11B
IC505	12O	IC511	9E	Q502	11I	Q505	11B	Q509	11C	D503	10O	D507	11N	D524	9B
IC508	11G	IC512	11L	Q503	12J	Q506	11B	D501	11O	D504	11O	D508	9G	D525	10D
														D526	9I
														D527	10
														D528	9I



# PC BOARD TK-760G/760HG

TX-RX UNIT (X57-5950-14) (B/2) : TK-760HG(K,M)

Component side view (J72-0992-09)

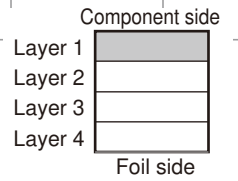
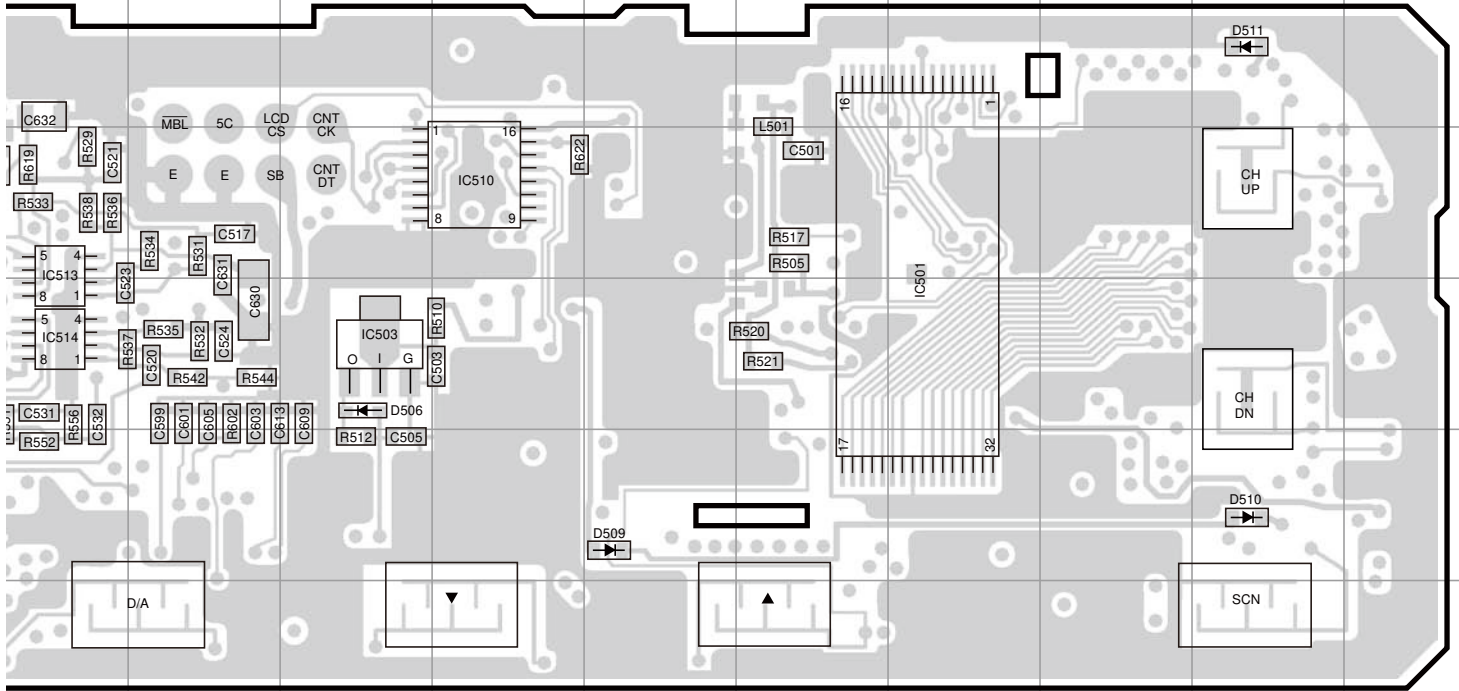

TX-RX UNIT (X57-5950-14) (B/2) : TK-760HG(K,M)

Foil side view (J72-0992-09)

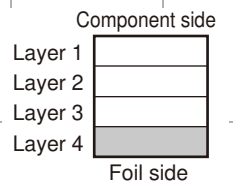
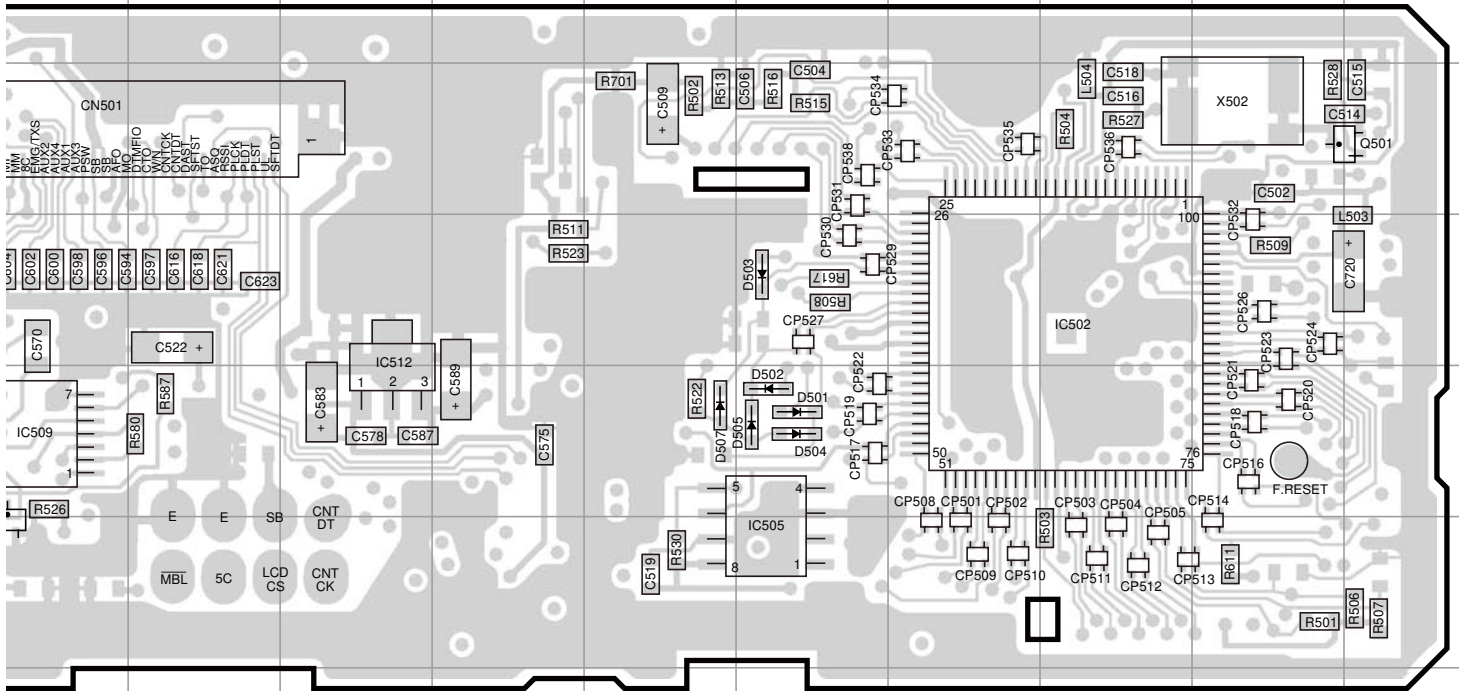

Ref. No.	Address
526	9D
527	10B
528	9D



# PC BOARD TK-760G/760HG

TX-RX UNIT (X57-5950-21) (A/2): TK-760G(M)  
Component side view (J79-0200-09)

Ref. No.	Address	Ref. No.	Address	Ref. No.	Address	Ref. No.	Address
IC3	10H	IC12	6O	Q11	11G	D25	4M
IC4	12M	IC13	8R	Q12	11G	D26	4O
IC5	12I	IC400	2I	Q35	12L	D34	5E
IC6	10M	Q2	12R	Q37	11L	D37	7D
IC7	9L	Q8	7F	Q38	12R	D40	11M
IC11	10J	Q9	10F	D9	9G	D41	11G

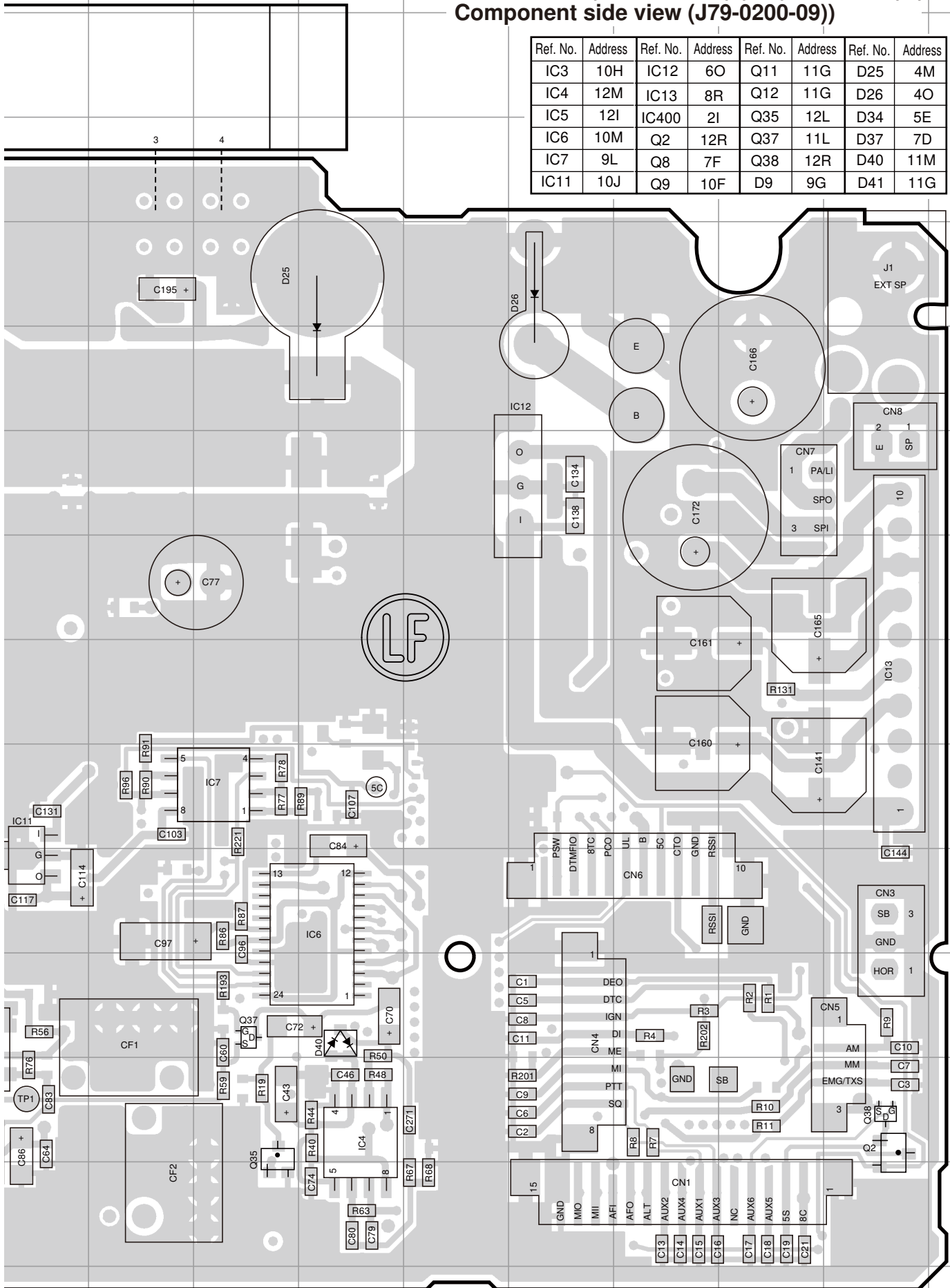

# TK-760G/760HG PC BOARD

TX-RX UNIT (X57-5950-21) (A/2) : TK-760G(M)

Foil side view (J79-0200-09)

Ref. No.	Address	Ref. No.	Address	Ref. No.	Address	Ref. No.	Address	Ref. No.	Address	Ref. No.	Address	Ref. No.	Address	Ref. No.	Address
IC1	11E	IC15	7O	Q6	11B	Q16	13M	Q22	7L	Q29	7G	D3	13C	D14	10H
IC2	9J	IC400	2K	Q7	11K	Q17	9B	Q23	7E	Q33	7N	D4	13C	D15	10B
IC8	9N	Q1	11B	Q10	13G	Q18	13N	Q24	8B	Q36	9K	D5	13D	D16	11N
IC9	9G	Q3	12H	Q13	13K	Q19	7C	Q26	8D	Q39	5G	D8	12J	D17	7L
IC10	8E	Q4	12H	Q14	10N	Q20	8C	Q27	9Q	D1	13D	D10	13I	D18	12Q
IC14	9D	Q5	11B	Q15	13O	Q21	7C	Q28	7I	D2	12B	D11	12G	D19	8B

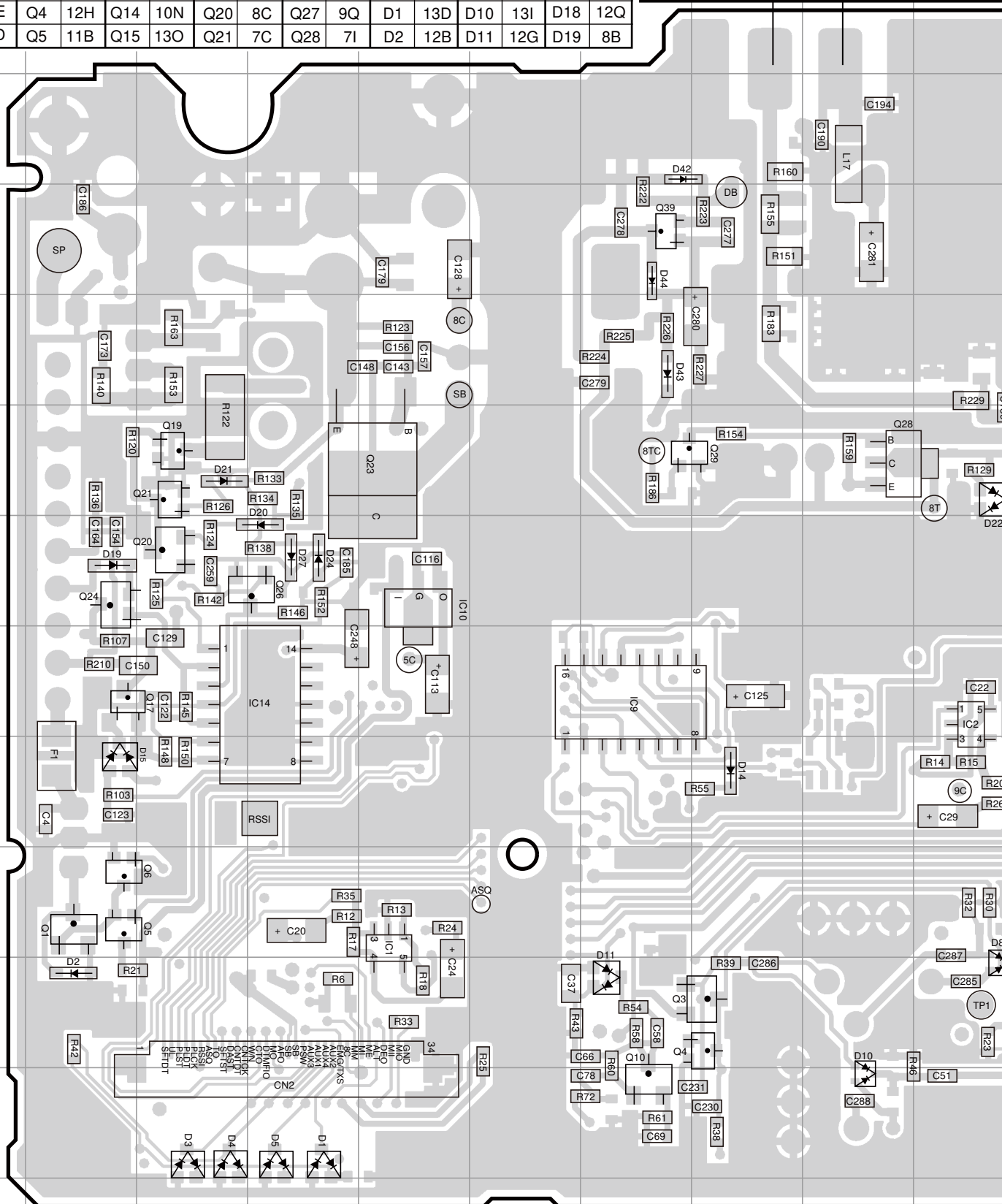

# PC BOARD TK-760G/760HG

TX-RX UNIT (X57-5950-21) (A/2) : TK-760G(M)

Foil side view (J79-0200-09)

Ref. No.	Address	Ref. No.	Address	Ref. No.	Address
D20	8D	D28	10Q	D42	4G
D21	7C	D30	8Q	D43	6G
D22	7J	D31	8Q	D44	5G
D23	10Q	D35	7Q		
D24	8D	D36	6R		
D27	8D	D39	8L		

Component side

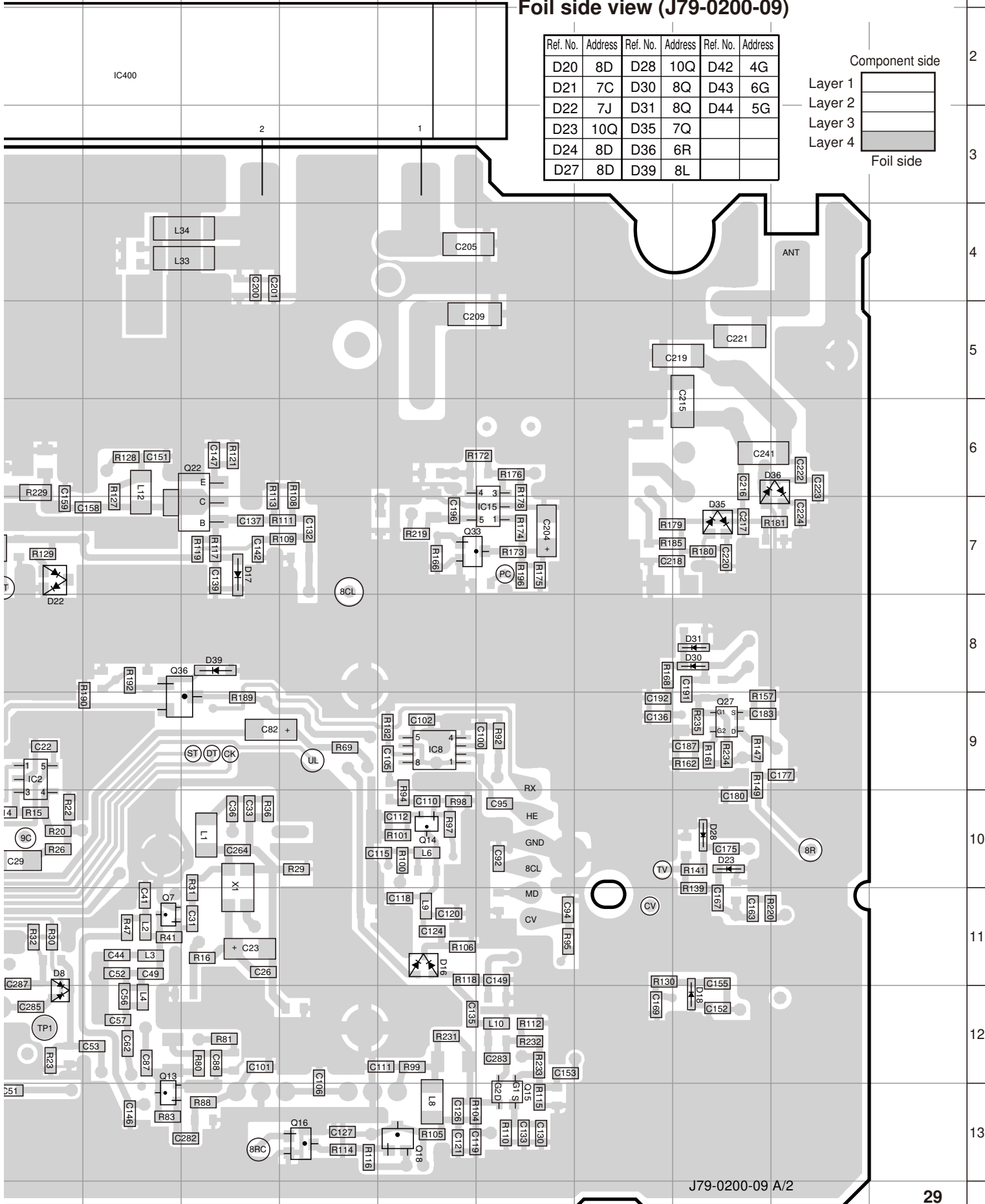
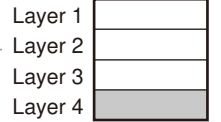

# TK-760G/760HG PC BOARD

TX-RX UNIT (X57-5950-21) (B/2) : TK-760G(M)

Component side view (J79-0200-09)

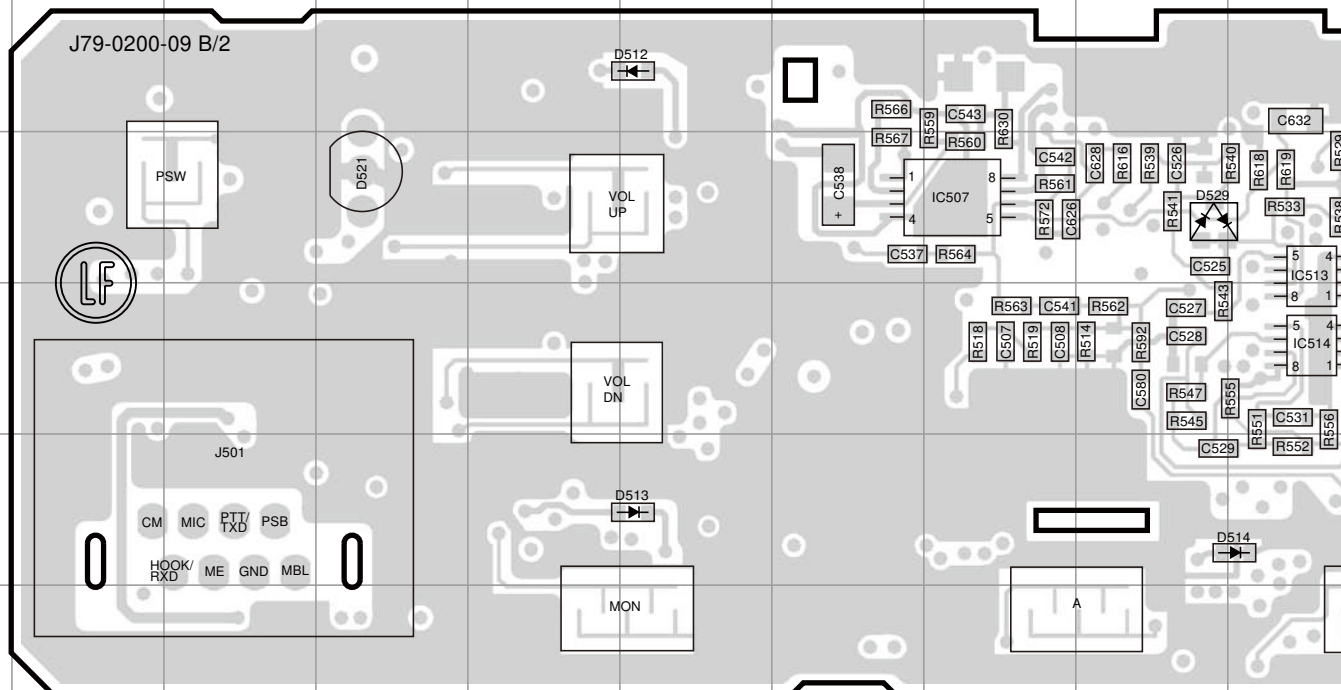

Ref. No.	Address	Ref. No.	Address	Ref. No.	Address	Ref. No.	Address	Ref. No.	Address
IC501	3P	IC510	3M	D506	4L	D511	2R	D514	5J
IC503	4L	IC513	3J	D509	5N	D512	2F	D521	3D
IC507	3H	IC514	4J	D510	5R	D513	5F	D529	3I

TX-RX UNIT (X57-5950-21) (B/2) : TK-760G(M)

Foil side view (J79-0200-09)

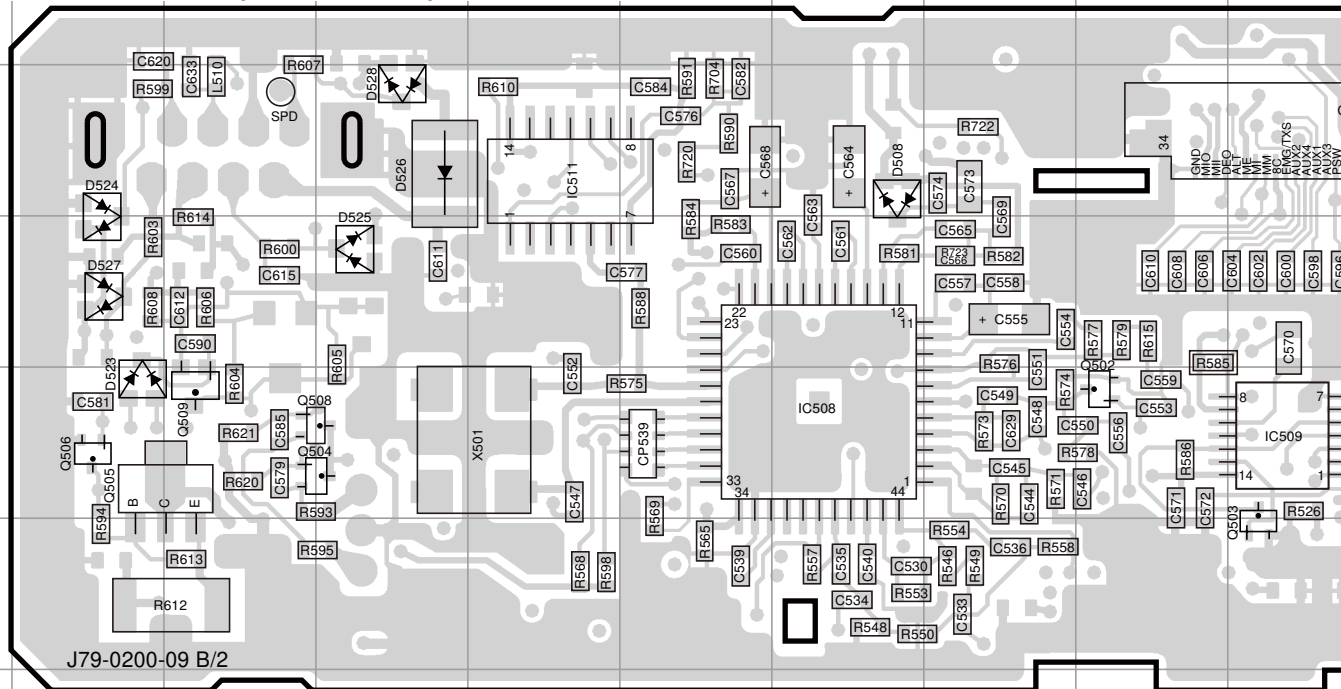

Ref. No.	Address	Ref. No.	Address	Ref. No.	Address	Ref. No.	Address	Ref. No.	Address	Ref. No.	Address	Ref. No.	Address	Ref. No.	Address
IC502	10Q	IC509	11J	Q501	9S	Q504	11C	Q508	11C	D502	11O	D505	11O	D523	11B
IC505	12O	IC511	9E	Q502	11I	Q505	11B	Q509	11C	D503	10O	D507	11N	D524	9B
IC508	11G	IC512	11L	Q503	12J	Q506	11B	D501	11O	D504	11O	D508	9G	D525	10D
														D526	9I
														D527	1C
														D528	9I

# PC BOARD TK-760G/760HG

TX-RX UNIT (X57-5950-21) (B/2) : TK-760G(M)

Component side view (J79-0200-09)

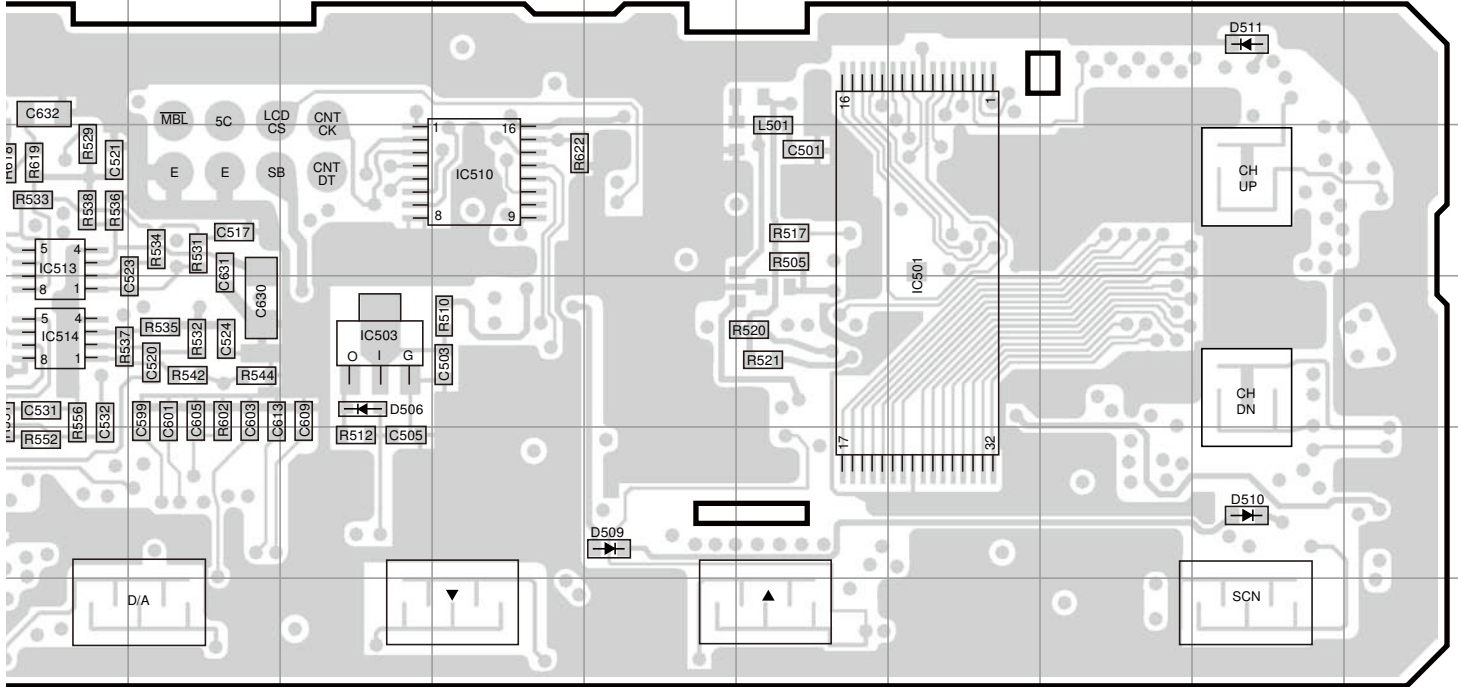

Component side

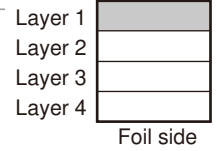

TX-RX UNIT (X57-5950-21) (B/2) : TK-760G(M)

Foil side view (J79-0200-09)

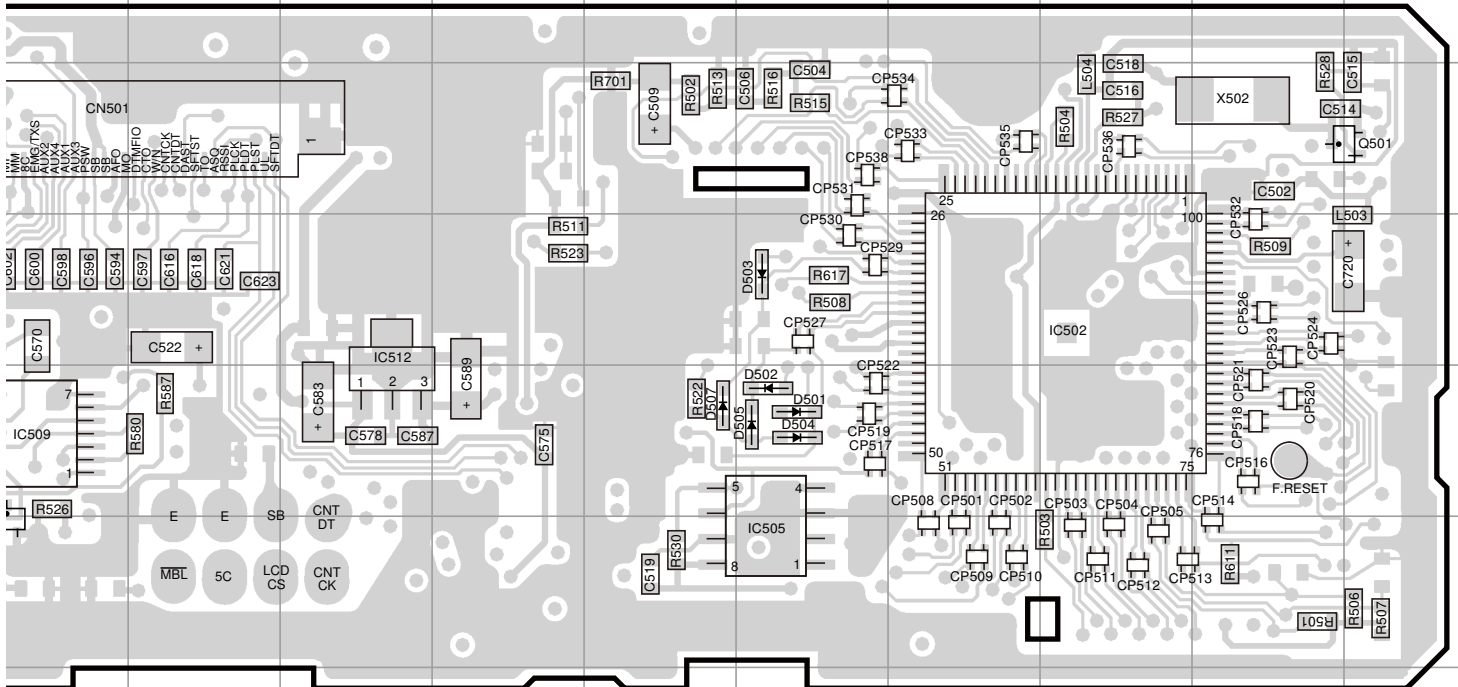

Component side

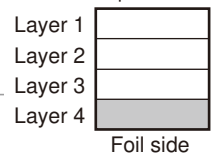

Ref. No.	Address
Y526	9D
Y527	10B
Y528	9D

# TK-760G/760HG SCHEMATIC DIAGRAM

TK-760G(K,K2)/760HG(K2)

DISPLY UNIT (X54-3270-10)

TX-RX UNI

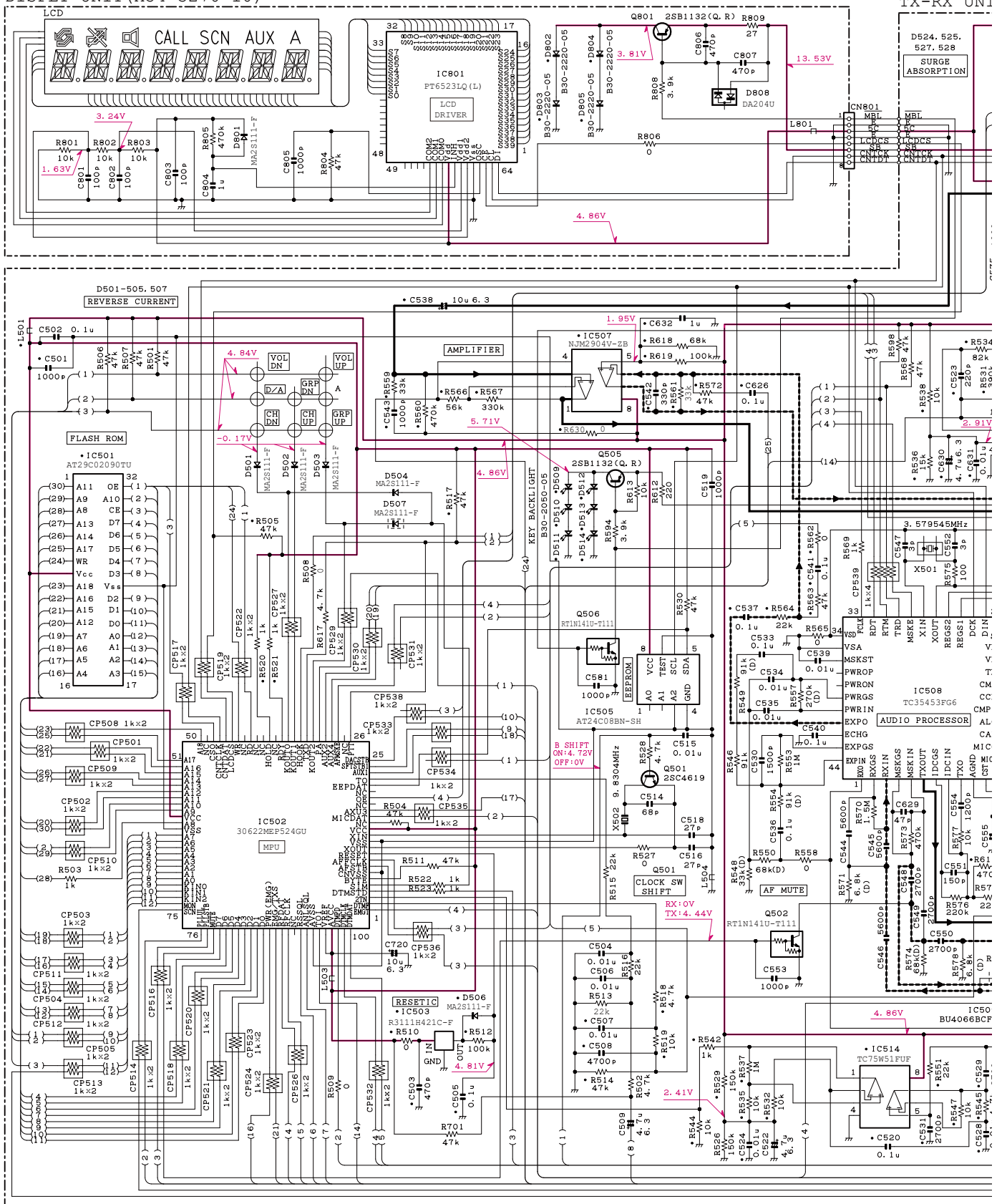

TX-RX UNIT (X57-5950-XX)(B)2: CONTROL SECTION



# SCHEMATIC DIAGRAM TK-760G/760HG

## -RX UNIT (X57-5950-XX) (B/2) : CONTROL SECTION

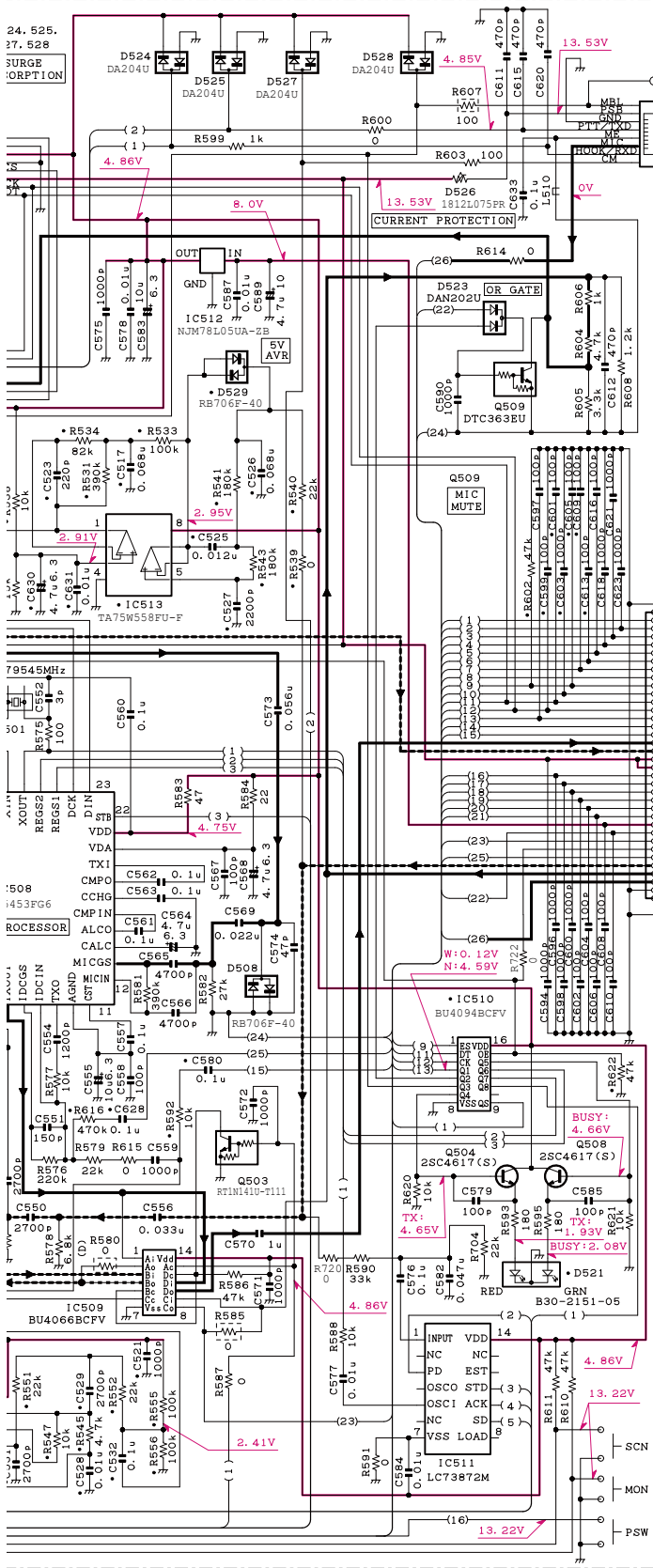

## TX-RX UNIT (X57-5950-XX) (A/2) : TX-RX SECTION

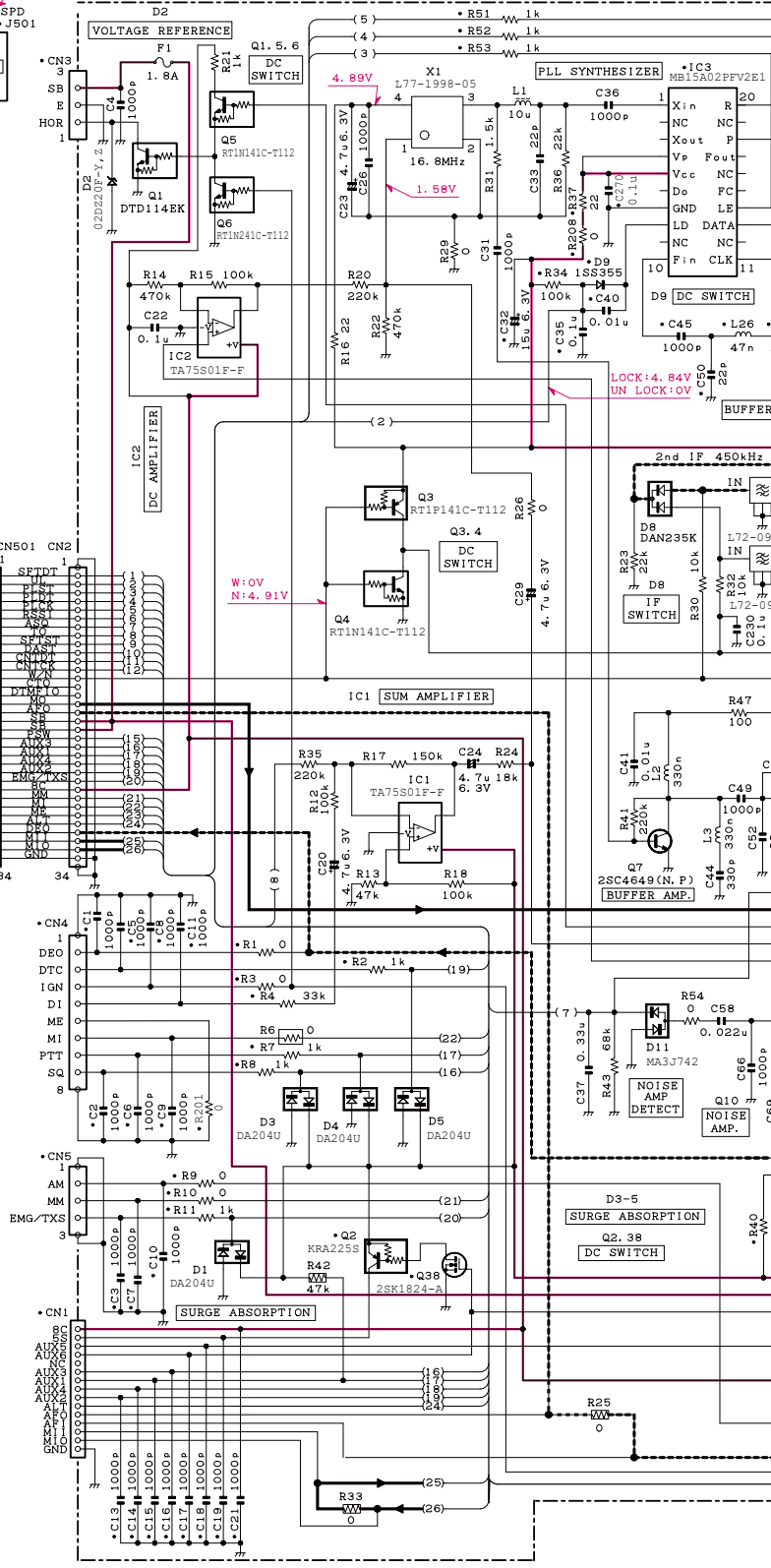

# TK-760G/760HG SCHEMATIC DIAGRAM

	X58-4670-XX	C105	C107	C110	C111	C114	C115	L111	L112
-10	TK-760G	K	15p	8p	4p	5p	6p	L34-4547-05	NO
-11	TK-760G,TK-760HG	K2	27p	6p	12p	4p	7p	NO	L34-4548-05

ION

TX-RX UNIT (X57-5950-XX)

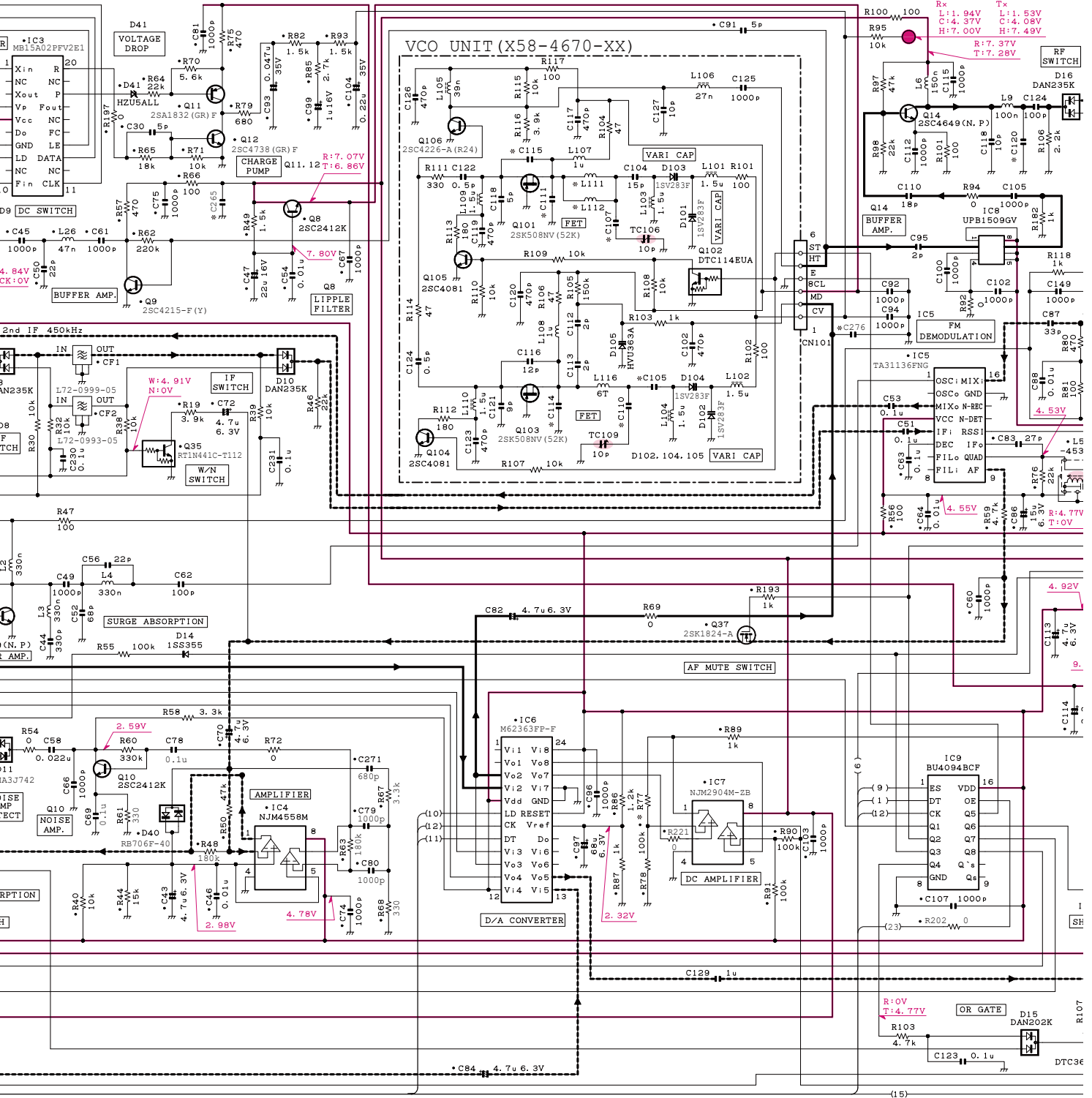

	X57-5950-XX	R77	C120	C265	C276
-10	TK-760G	K	150k	22p	NO
-12	TK-760G	K2	180k	33p	NO
-16	TK-760HG	K2	180k	33p	1000p

# SCHEMATIC DIAGRAM TK-760G/760HG

X57-5950-XX	R147	R151	R155	R160	R166	R173	R179	R186	IC400	
-10 TK-760G	K	1.5k	330	15	330	180	3.3k	22k	0	M67741H-32
-12 TK-760G	K2	1.5k	330	15	330	180	3.3k	22k	0	M67741L-35
-16 TK-760HG	K2	1.5k	470	12	470	220	2.2k	27k	10	M68702L

X57-5950-XX	D33	D37	
-10 TK-760G	K	L709CER-T	NO
-12 TK-760G	K2	L709CER-T	NO
-16 TK-760HG	K2	NO	MA4PH633

## TX-RX UNIT (X57-5950-XX)

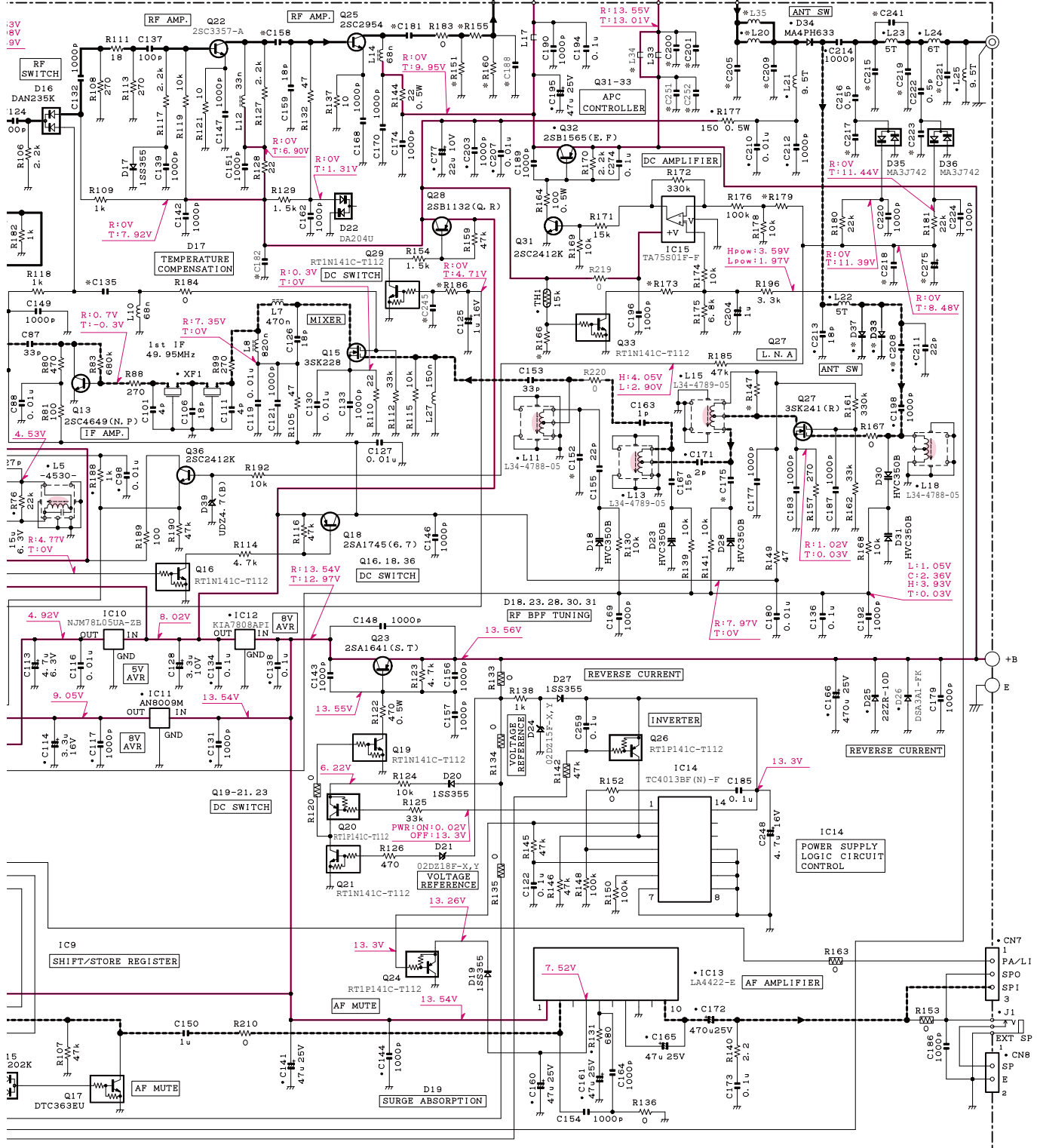

X57-5950-XX	C135	C152	C158	C175	C181	C182	C188	C200	C201	C205	C208	C209	C215	C217	C218	C219	C221	C223	C241	C245	C251	C252	C275	L20	L34	L35	
-10 TK-760G	K	9p	3p	39p	8p	12p	NO	NO	1000p	0.1u	10p	3p	22p	12p	1p	0.1u	27p	18p	1p	4p	NO	NO	NO	NO	L34-4481-15	NO	NO
-12 TK-760G	K2	12p	5p	39p	10p	12p	NO	NO	1000p	0.1u	8p	4p	18p	12p	1p	NO	27p	27p	2p	5p	NO	NO	NO	NO	NO	NO	L34-4480-15
-16 TK-760HG	K2	12p	5p	22p	10p	39p	1000p	6p	NO	NO	18p	4p	22p	10p	2p	0.1u	18p	15p	1p	3p	0.1u	1000p	0.1u	NO	L34-4481-15	L32-0179-05	NO

Note : The components marked with a dot (•) are parts of layer 1.

# TK-760G/760HG SCHEMATIC DIAGRAM

TK-760G(M)/760HG(K,M)

DISPLY UNIT (X54-3270-10)

TX-RX UNI

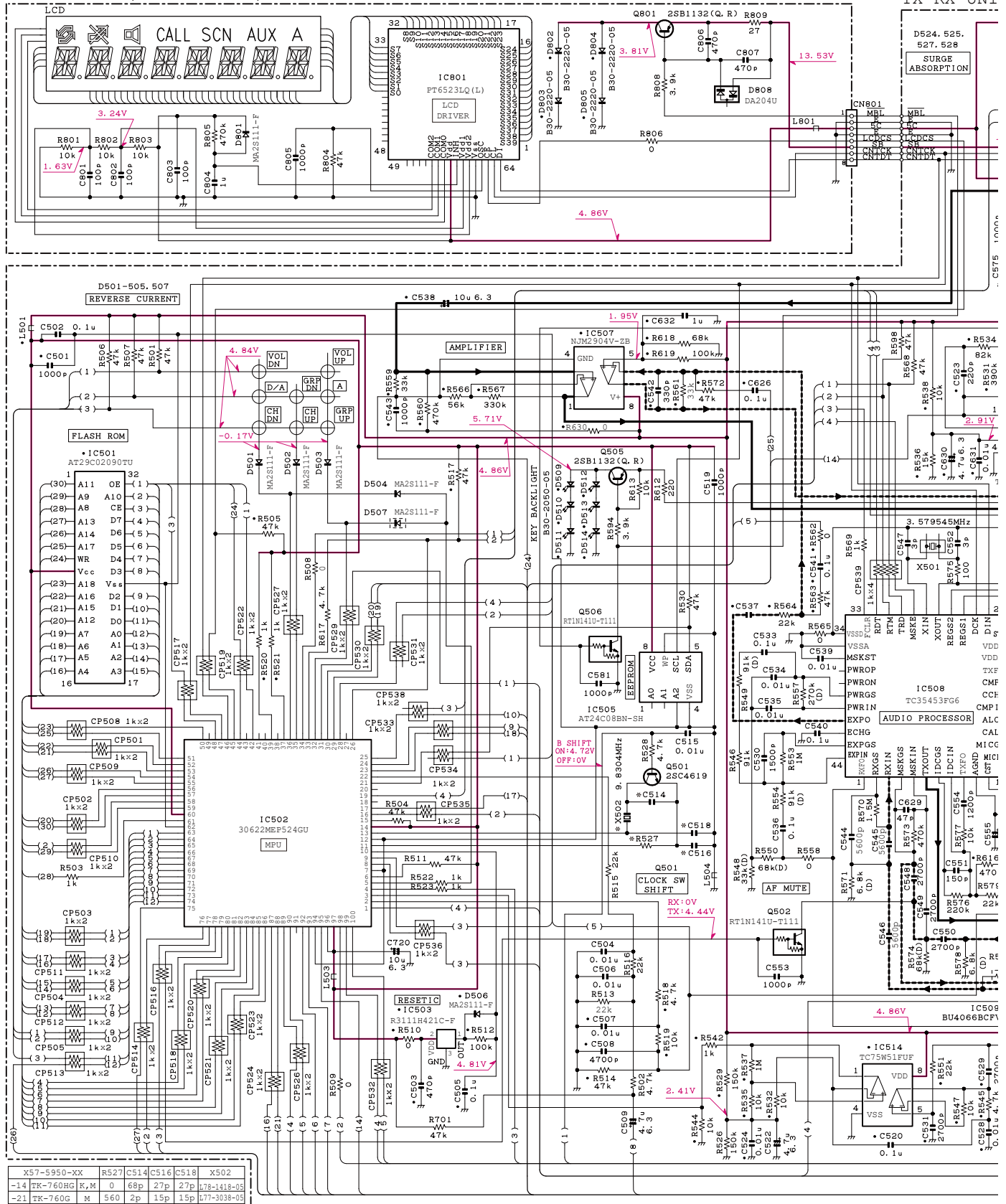

TX-RX UNIT (X57-5950-XX)(B/2): CONTROL SECTION

X57-5950-XX	R527	C514	C516	C518	X502
-14 TK-760HG K,M	0	68p	27p	27p	E78-1418-05
-21 TK-760G M	560	2p	15p	15p	E77-3038-05

# SCHEMATIC DIAGRAM TK-760G/760HG

-RX UNIT(X57-5950-XX) (B/2):CONTROL SECTION

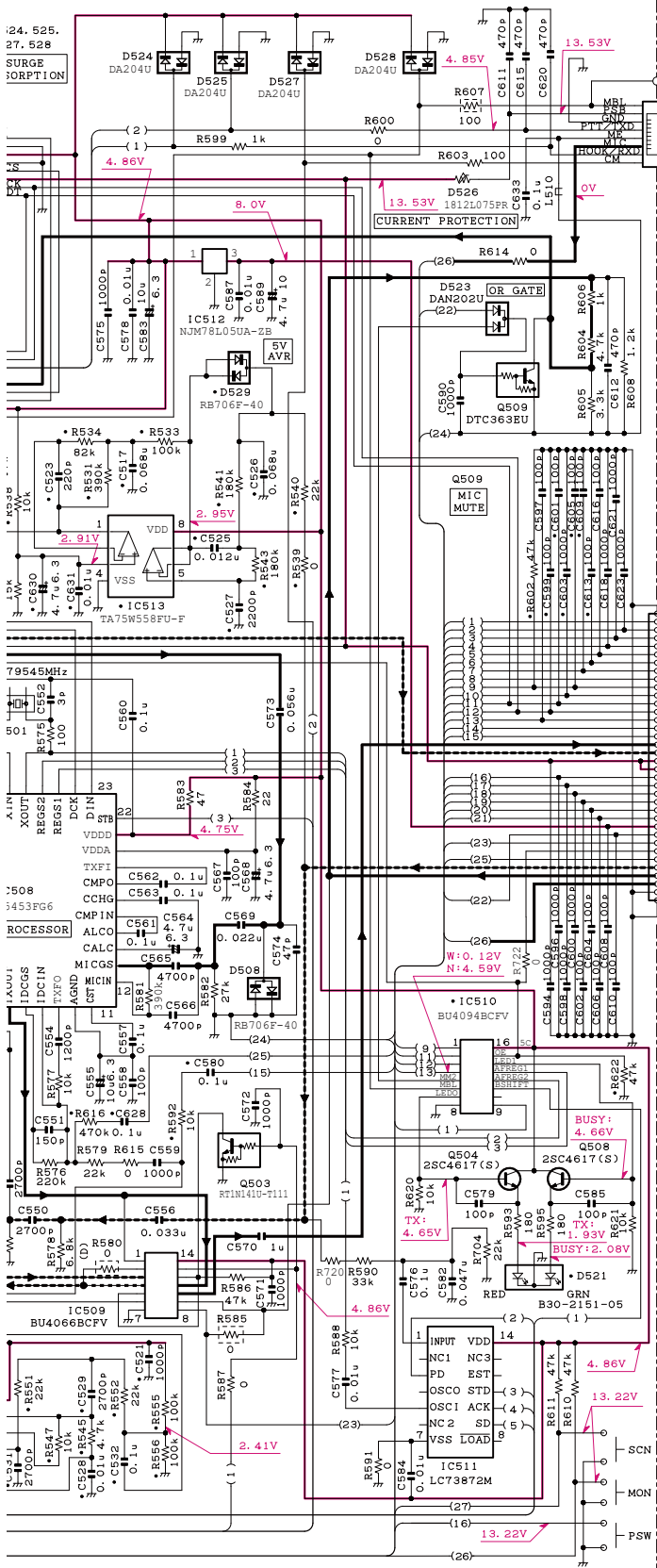

X57-5950-XX	C31	C264	R17	R31	R41	D8	Q4	Q5	Q6	CN1	CN5	X1	L2
-14	TK-760HG	K, M	1000p	NO	150k	1.5k	220k	DAN235K	TKR04C-1111	TKR04C-1111	TKR04C-1111	TKR04C-1111	330n
-21	TK-760G	M	47p	22p	220k	4.7k	100k	DAN235E	TKR04C-1111	TKR04C-1111	TKR04C-1111	TKR04C-1111	1u

TX-RX UNIT(X57-5950-XX) (A/2):TX-RX SECTION

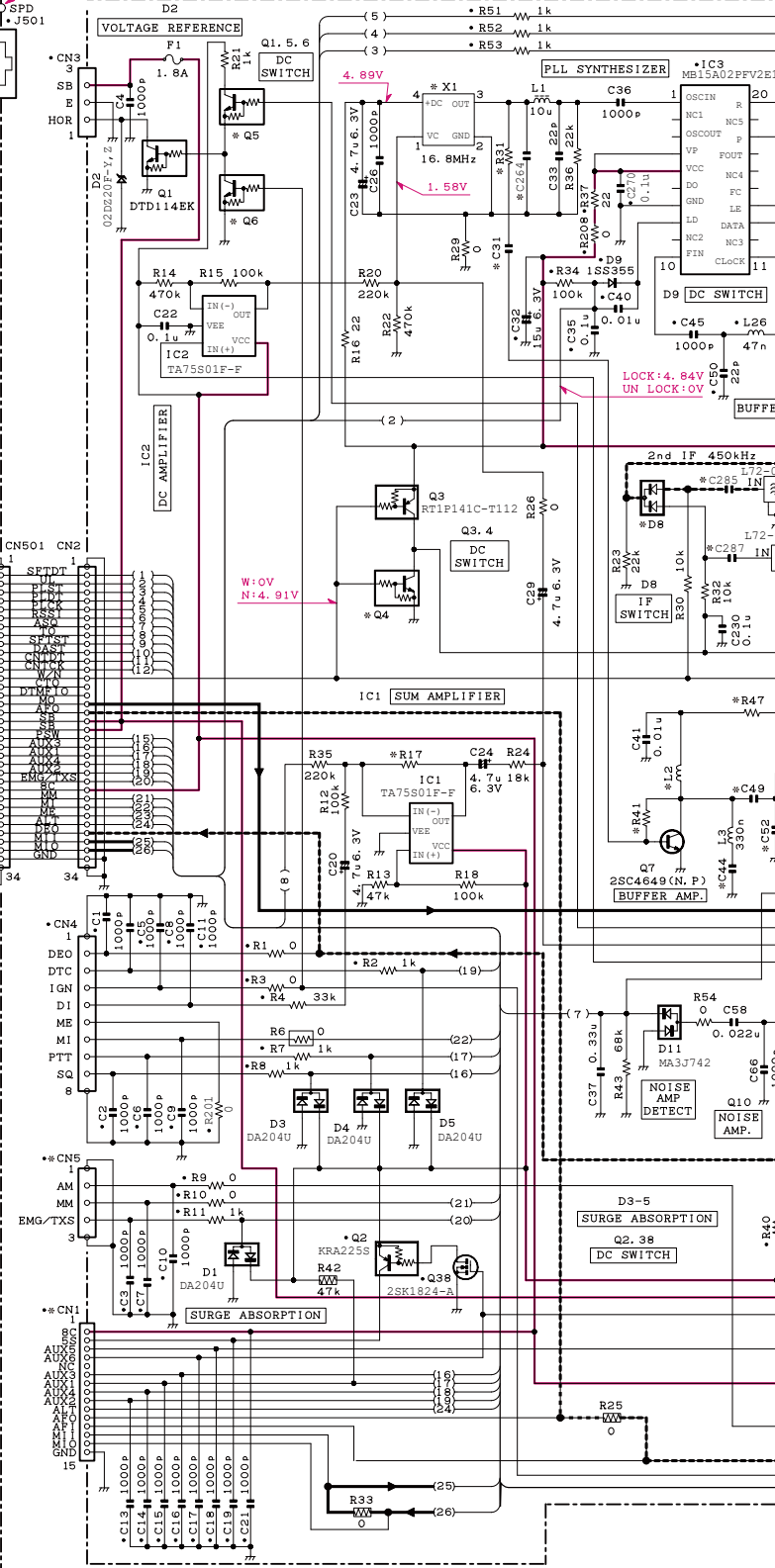

# TK-760G/760HG SCHEMATIC DIAGRAM

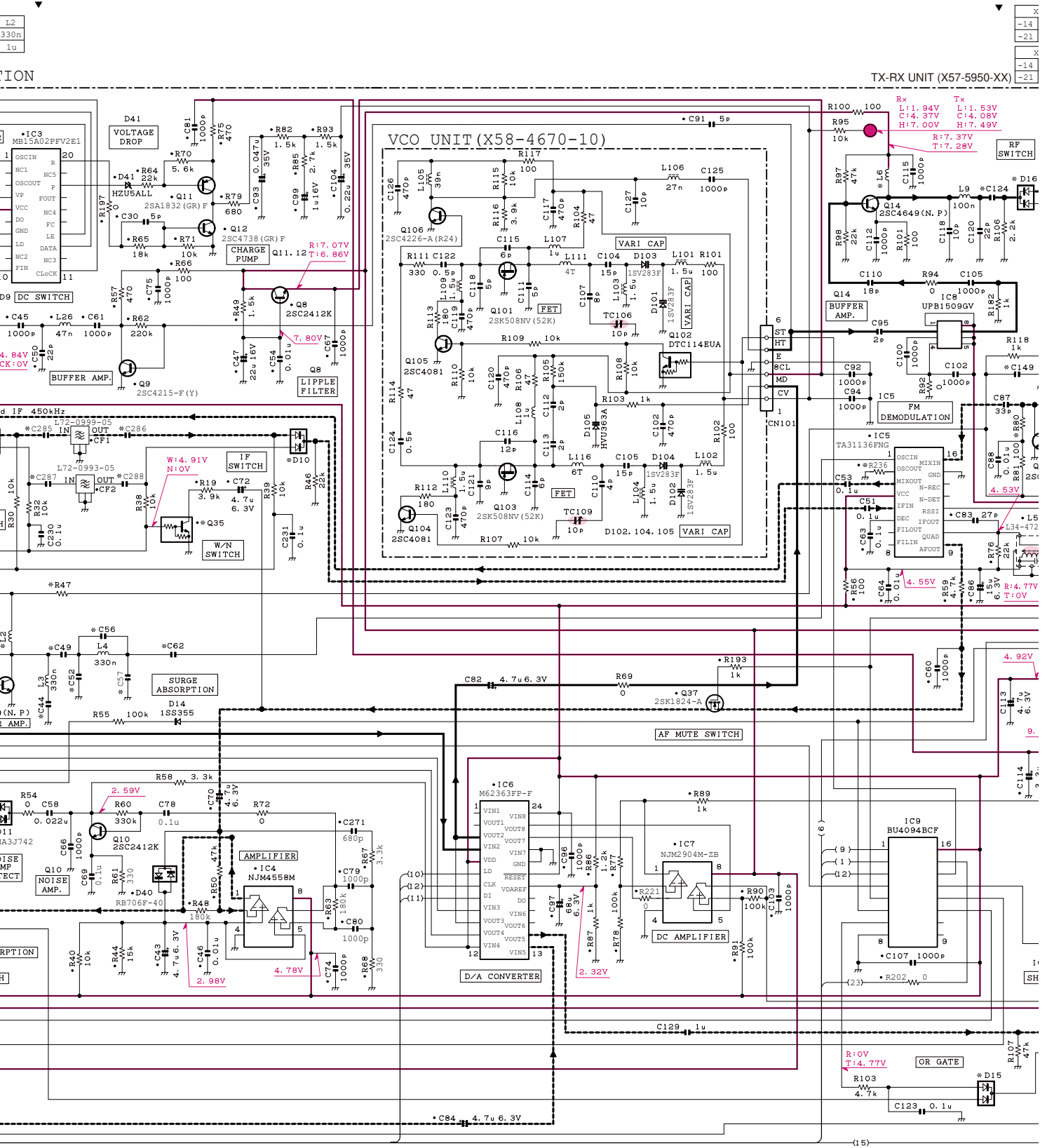

	X57-5950-XX	C44	C49	C52	C56	C57	C62	C124	C285	C286	C287	C288	R47	R236	L6	D10	D15	Q35
-14	TK-760HG	K,M	330p	1000p	68p	22p	NO	100p	100p	NO	NO	NO	100	NO	L40-1581-86	DAN235R	DAN202R	FHM4141-M112
-21	TK-760G	M	270p	47p	82p	20p	8p	47p	1000p	0.1u	0.1u	0.1u	220	3.3k	L40-1885-92	DAN235E	DAN202U	FHM4141-M111

# SCHEMATIC DIAGRAM TK-760G/760HG

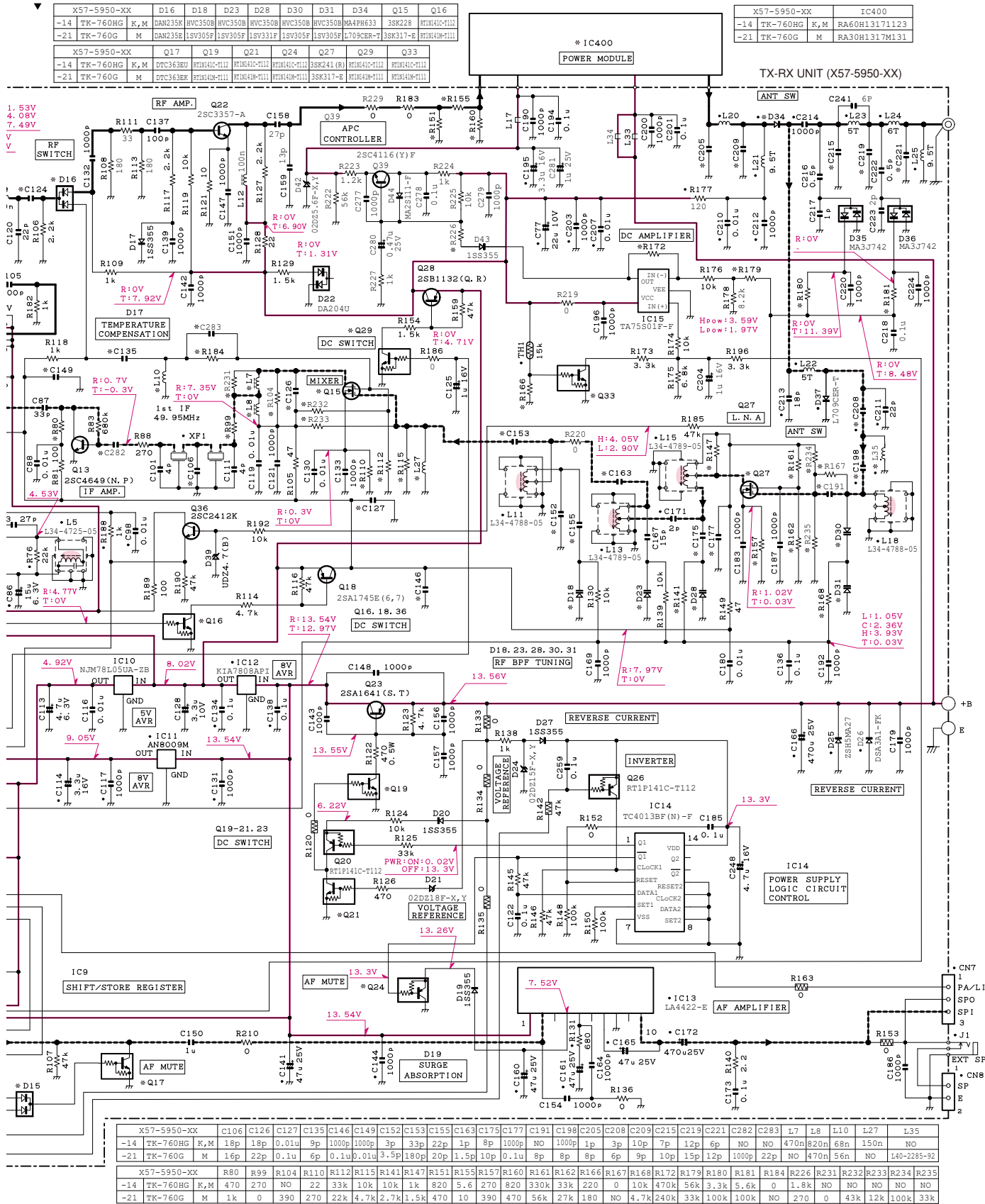

Note : The components marked with a dot (•) are parts of layer 1.

# TK-760G/760HG

## Kenwood Corporation

2967-3, Ishikawa-machi, Hachioji-shi, Tokyo, 192-8525 Japan

### Kenwood U.S.A. Corporation

P.O. BOX 22745, 2201 East Dominguez Street, Long Beach,  
CA 90801-5745, U.S.A.

### Kenwood Electronics Canada Inc.

6070 Kestrel Road, Mississauga, Ontario, Canada L5T 1S8

### Kenwood Electronics Deutschland GmbH

Rembrücker Str. 15, 63150 Heusenstamm, Germany

### Kenwood Electronics Belgium N.V.

Leuvensesteenweg 248 J, 1800 Vilvoorde, Belgium

### Kenwood Electronics France S.A.

L'Etoile Paris Nord 2, 50 Allée des Impressionnistes,  
Bp 58416 Villepinte, 95944 Roissy Ch De Gaulle Cedex

### Kenwood Electronics UK Limited

KENWOOD House, Dwight Road, Watford, Herts.,  
WD18 9EB United Kingdom

### Kenwood Electronics Europe B.V.

Amsterdamseweg 37, 1422 AC Uithoorn, The Netherlands

### Kenwood Electronics Italia S.p.A.

Via G. Sirtori, 7/9 20129 Milano, Italy

### Kenwood Ibérica, S.A.

Carretera de Rubi, 88 Planta 1 A 08174 Sant Cugat del Vallès  
Barcelona, Spain

### Kenwood Electronics Australia Pty. Ltd.

Talavera Business Park Building A, 4 Talavera Road,  
North Ryde NSW 2113 Australia

### Kenwood Electronics (Hong Kong) Ltd.

Suite 2504, 25/F, Tower 2, Nina Tower, No. 8 Yeung Uk Road,  
Tsuen Wan, New Territories, Hong Kong

### Kenwood Electronics Singapore Pte Ltd

1 Ang Mo Kio Street 63, Singapore 569110



# TK-760G/760HG PC BOARD

TX-RX UNIT (X57-5950-XX) (A/2) -10: TK-760G(K) -12: TK-760G(K2) -16: TK-760HG(K2)  
Component side view (J72-0759-12)

# PC BOARD TK-760G/760HG

TX-RX UNIT (X57-5950-XX)(A/2) -10: TK-760G(K) -12: TK-760G(K2) -16: TK-760HG(K2)  
Component side view (J72-0759-12)

Ref. No.	Address	Ref. No.	Address	Ref. No.	Address	Ref. No.	Address
IC3	10H	IC13	8R	Q32	4O	D34	5E
IC4	12M	IC400	2I	Q35	12L	D37	7D
IC5	12I	Q2	12R	Q37	11L	D40	11M
IC6	10M	Q8	7G	Q38	12R	D41	11G
IC7	9L	Q9	10F	D9	9G		
IC11	10J	Q11	11G	D25	5O		
IC12	6O	Q12	11G	D26	4L		

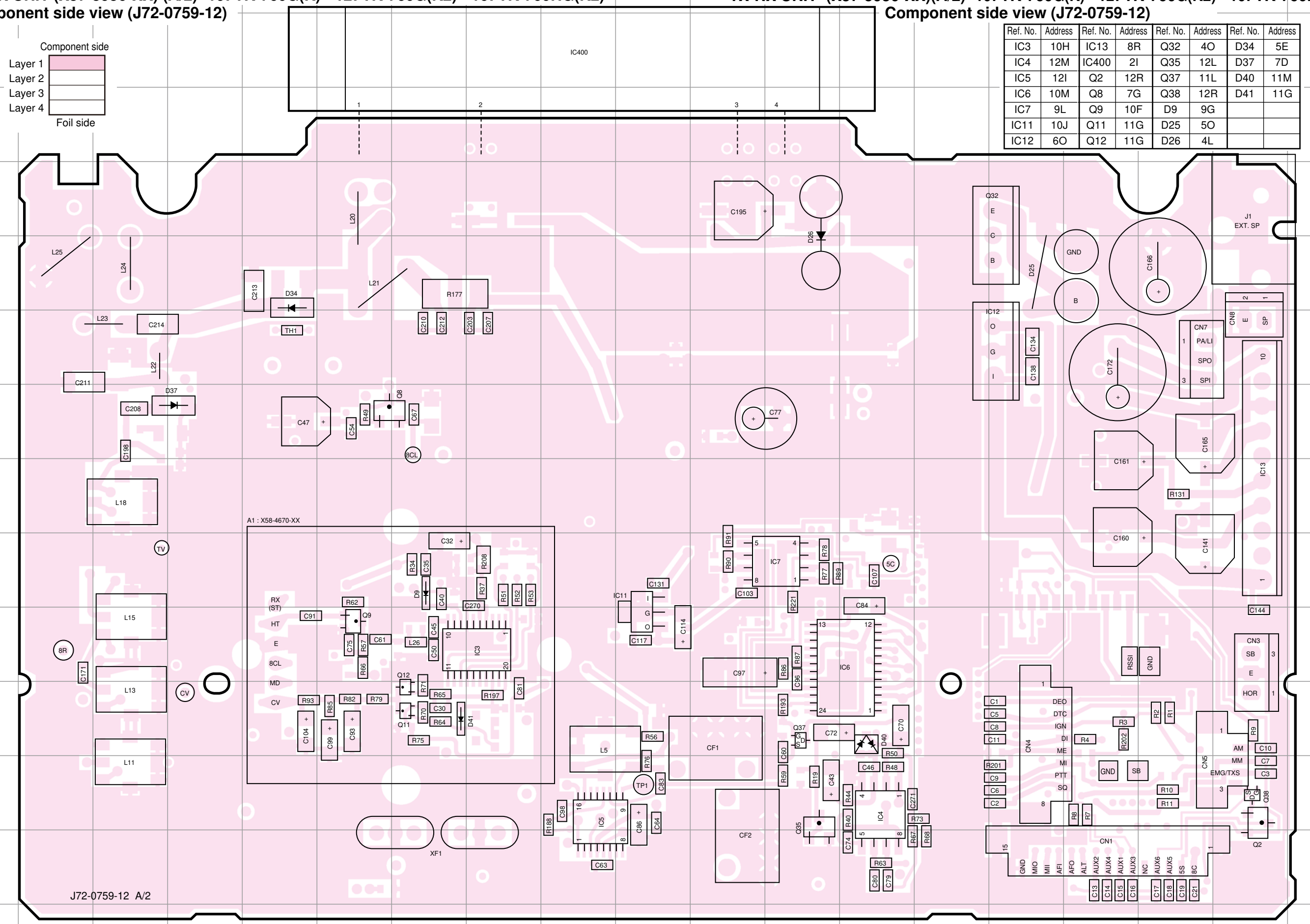
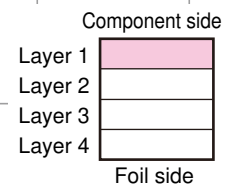

A1 : X58-4670-XX

J72-0759-12 A/2



# TK-760G/760GH PC BOARD

TX-RX UNIT (X57-5950-XX) (B/2) -10: TK-760G(K) -12: TK-760G(K2) -16: TK-760HG(K2)  
Component side view (J72-0759-12)

# PC BOARD TK-760G/760GH

TX-RX UNIT (X57-5950-XX) (B/2) -10: TK-760G(K) -12: TK-760G(K2) -16: TK-760HG(K2)  
Component side view (J72-0759-12)

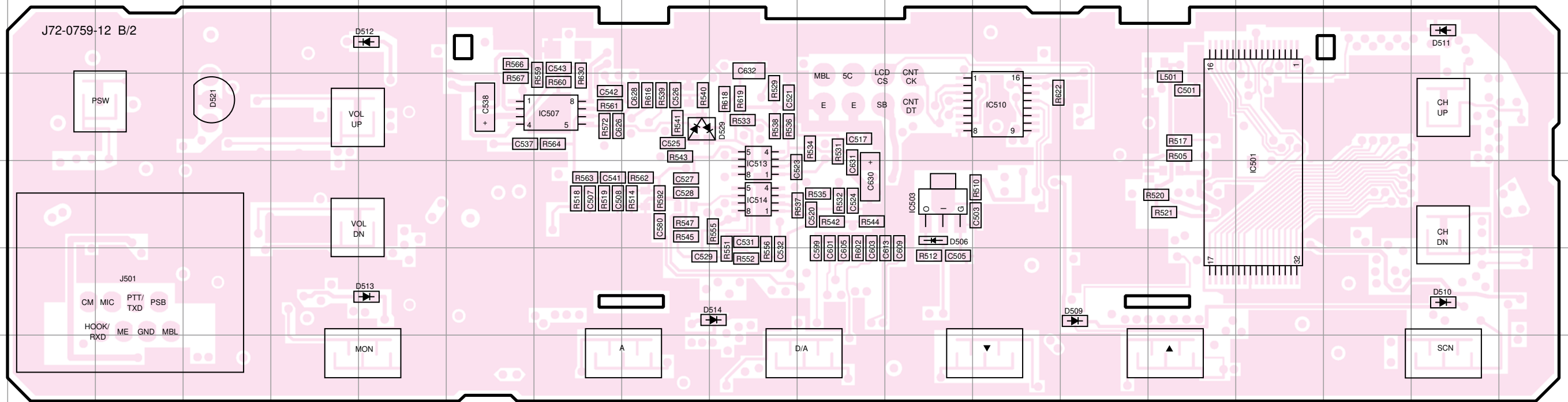

Ref. No.	Address	Ref. No.	Address	Ref. No.	Address	Ref. No.	Address	Ref. No.	Address
IC501	3P	IC510	3M	D506	4L	D511	2R	D514	5J
IC503	4L	IC513	3J	D509	5N	D512	2F	D521	3D
IC507	3H	IC514	4J	D510	5R	D513	5F	D529	3I

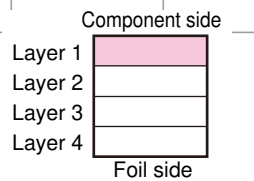

TX-RX UNIT (X57-5950-XX) (B/2) -10: TK-760G(K) -12: TK-760G(K2) -16: TK-760HG(K2)  
Foil side view (J72-0759-12)

TX-RX UNIT (X57-5950-XX) (B/2) -10: TK-760G(K) -12: TK-760G(K2) -16: TK-760HG(K2)  
Foil side view (J72-0759-12)

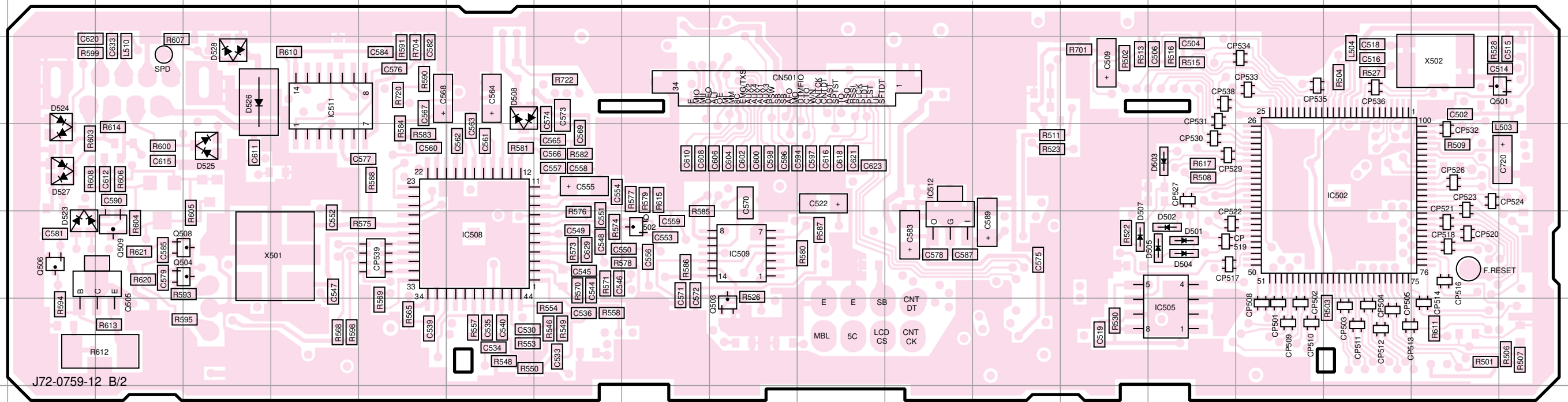

Ref. No.	Address	Ref. No.	Address	Ref. No.	Address	Ref. No.	Address	Ref. No.	Address	Ref. No.	Address	Ref. No.	Address	Ref. No.	Address
IC502	10Q	IC509	11J	Q501	9S	Q504	11C	Q508	11C	D502	11O	D505	11O	D523	11B
IC505	12O	IC511	9E	Q502	11I	Q505	11B	Q509	11C	D503	10O	D507	11N	D524	11B
IC508	11G	IC512	11L	Q503	12H	Q506	11B	D501	11O	D504	11O	D508	9G	D525	10D

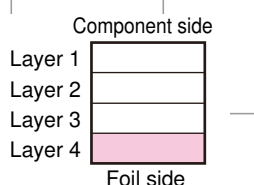

# TK-760G/760HG PC BOARD

TX-RX UNIT (X57-5950-14) (A/2): TK-760HG(K,M)

Component side view (J72-0992-09)

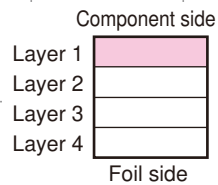

# PC BOARD TK-760G/760HG

TX-RX UNIT (X57-5950-14)(A/2) : TK-760HG(K,M)

Component side view (J72-0992-09)

Ref. No.	Address	Ref. No.	Address	Ref. No.	Address	Ref. No.	Address
IC3	10H	IC12	6O	Q11	11G	D25	4M
IC4	12M	IC13	8R	Q12	11G	D26	4O
IC5	12I	IC400	2I	Q35	12L	D34	5E
IC6	10M	Q2	12R	Q37	11L	D37	7D
IC7	9L	Q8	7F	Q38	12R	D40	11M
IC11	10J	Q9	10F	D9	9G	D41	11G

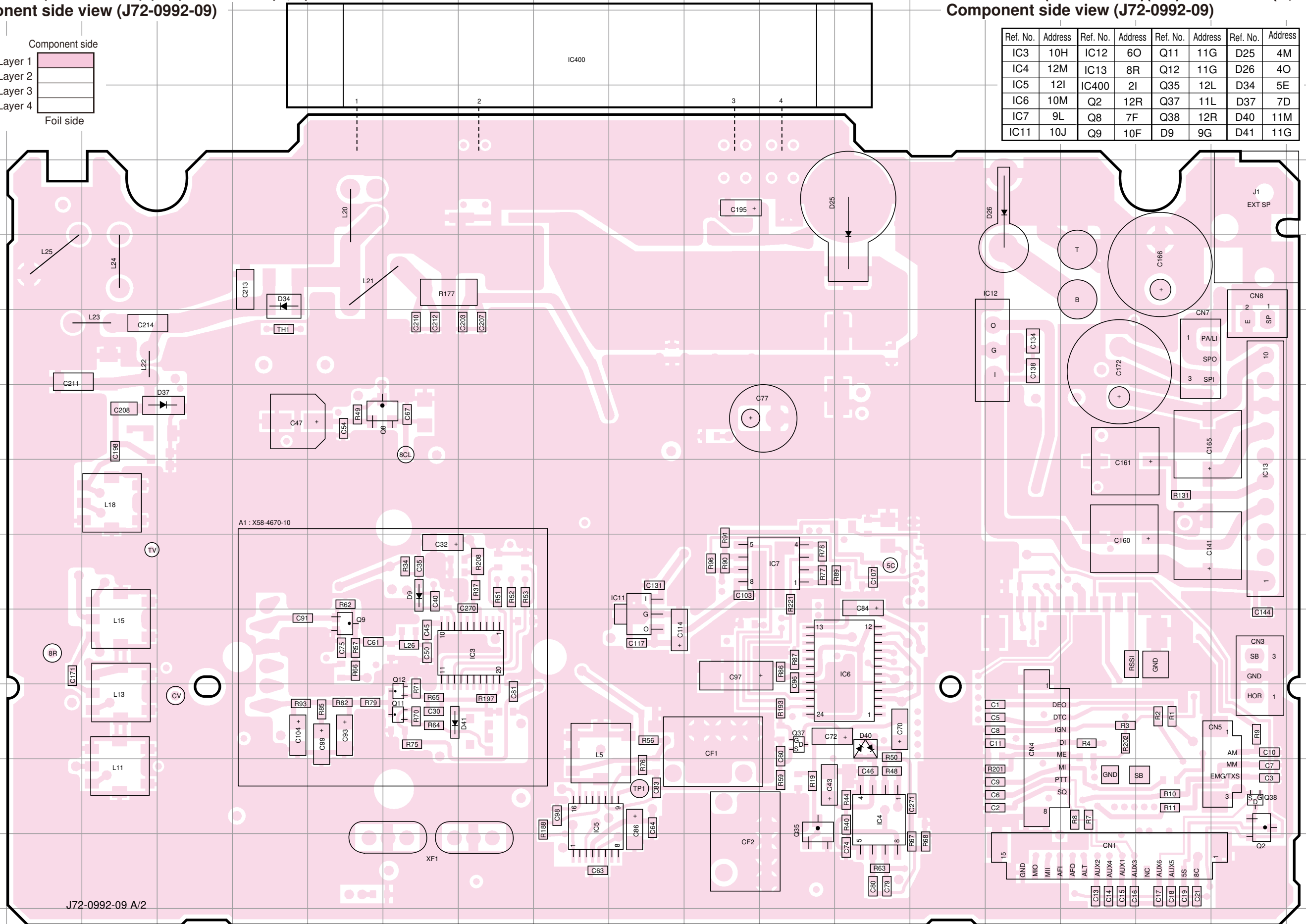

J72-0992-09 A/2

1 2 3 4 5 6 7 8 9 10 11 12 13 14

# TK-760G/760HG PC BOARD

TX-RX UNIT (X57-5950-14) (A/2) : TK-760HG(K,M)

Foil side view (J72-0992-09)

# PC BOARD TK-760G/760HG

TX-RX UNIT (X57-5950-14) (A/2) : TK-760HG(K,M)

Foil side view (J72-0992-09)

Ref. No.	Address	Ref. No.	Address	Ref. No.	Address	Ref. No.	Address	Ref. No.	Address	Ref. No.	Address	Ref. No.	Address	Ref. No.	Address
IC1	11E	IC15	7O	Q6	11B	Q16	13M	Q22	7L	Q29	7G	D3	13C	D14	10H
IC2	9J	IC400	2K	Q7	11K	Q17	9B	Q23	7E	Q33	7N	D4	13C	D15	10B
IC8	9N	Q1	11B	Q10	13G	Q18	13N	Q24	8B	Q36	9K	D5	13D	D16	11N
IC9	9G	Q3	12H	Q13	13K	Q19	7C	Q26	8D	Q39	5G	D8	12J	D17	7L
IC10	8E	Q4	12H	Q14	10N	Q20	8C	Q27	9Q	D1	13D	D10	13I	D18	12Q
IC14	9D	Q5	11B	Q15	13O	Q21	7C	Q28	7I	D2	12B	D11	12G	D19	8B

Ref. No.	Address	Ref. No.	Address	Ref. No.	Address
D20	8D	D28	10Q	D42	4G
D21	7C	D30	8Q	D43	6G
D22	7J	D31	8Q	D44	5G
D23	10Q	D35	7Q		
D24	8D	D36	6R		
D27	8D	D39	8L		

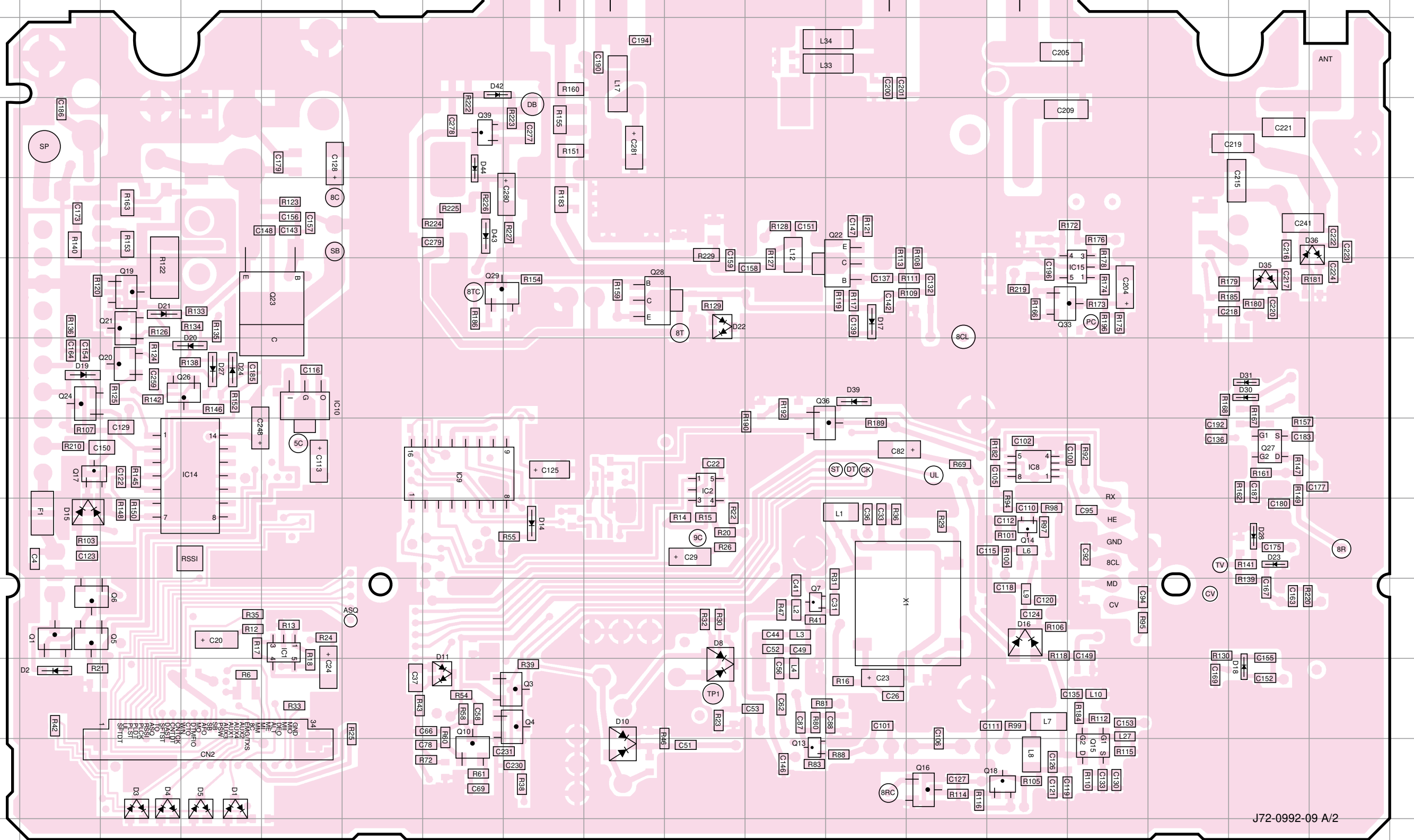
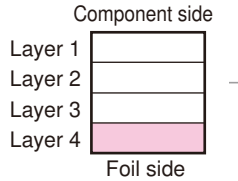

# TK-760G/760HG PC BOARD

TX-RX UNIT (X57-5950-14) (B/2) : TK-760HG(K,M)  
Component side view (J72-0992-09)

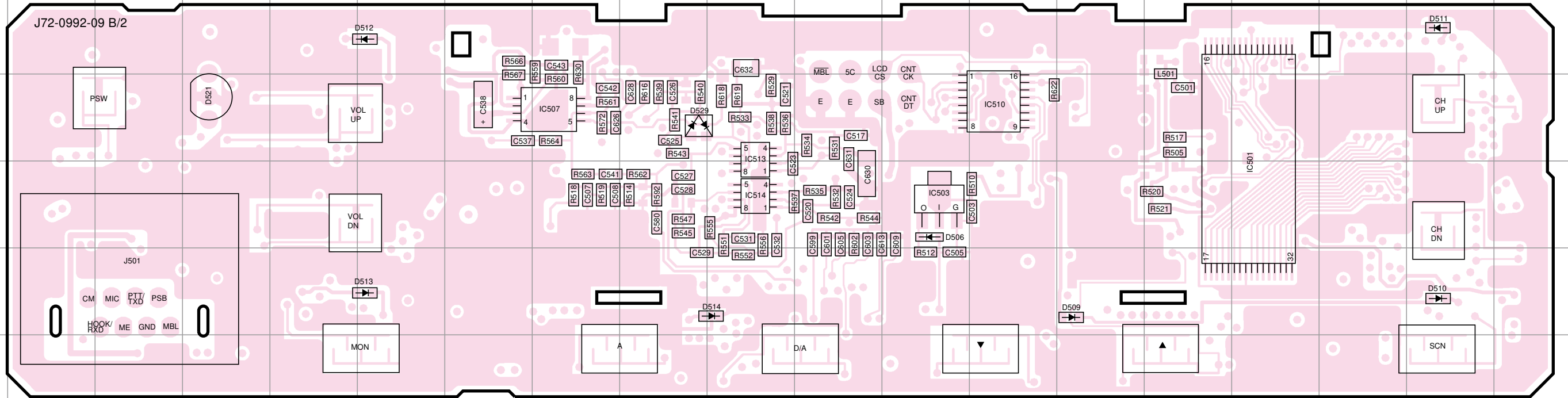

# PC BOARD TK-760G/760HG

TX-RX UNIT (X57-5950-14) (B/2) : TK-760HG(K,M)  
Component side view (J72-0992-09)

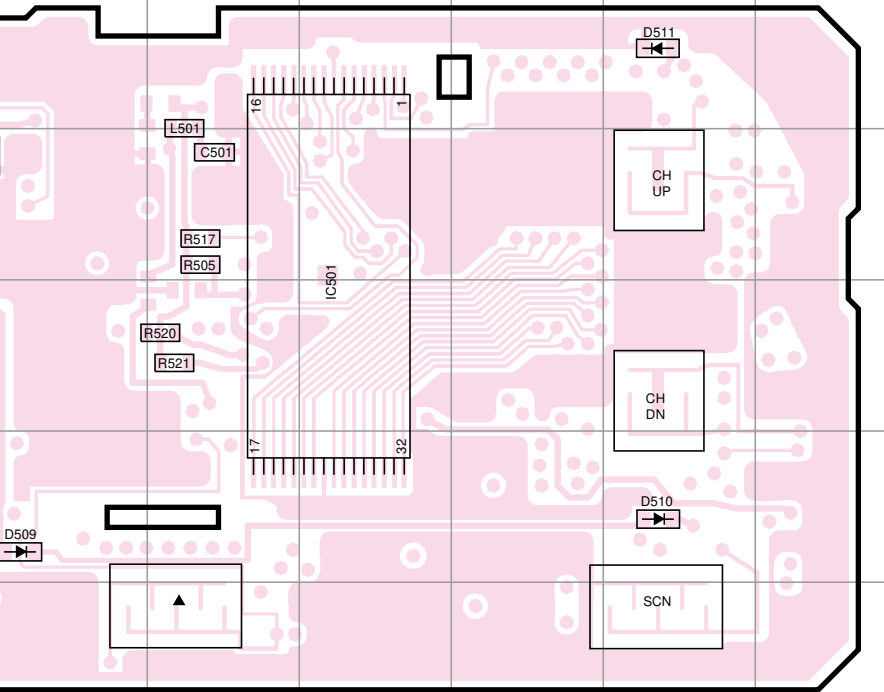

Ref. No.	Address	Ref. No.	Address	Ref. No.	Address	Ref. No.	Address	Ref. No.	Address
IC501	3P	IC510	3M	D506	4L	D511	2R	D514	5J
IC503	4L	IC513	3J	D509	5N	D512	2F	D521	2D
IC507	3H	IC514	4J	D510	5R	D513	5F	D529	3I

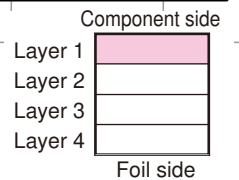

## TX-RX UNIT (X57-5950-14) (B/2) : TK-760HG(K,M) Foil side view (J72-0992-09)

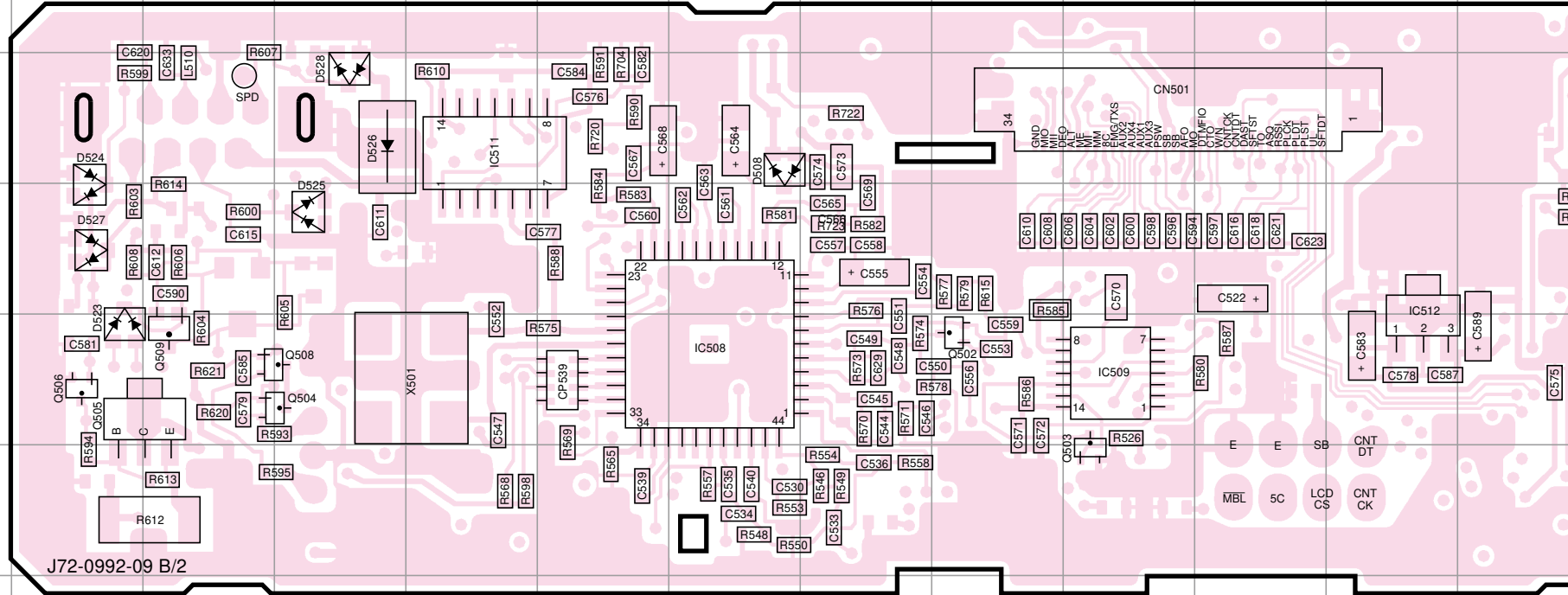

## TX-RX UNIT (X57-5950-14) (B/2) : TK-760HG(K,M) Foil side view (J72-0992-09)

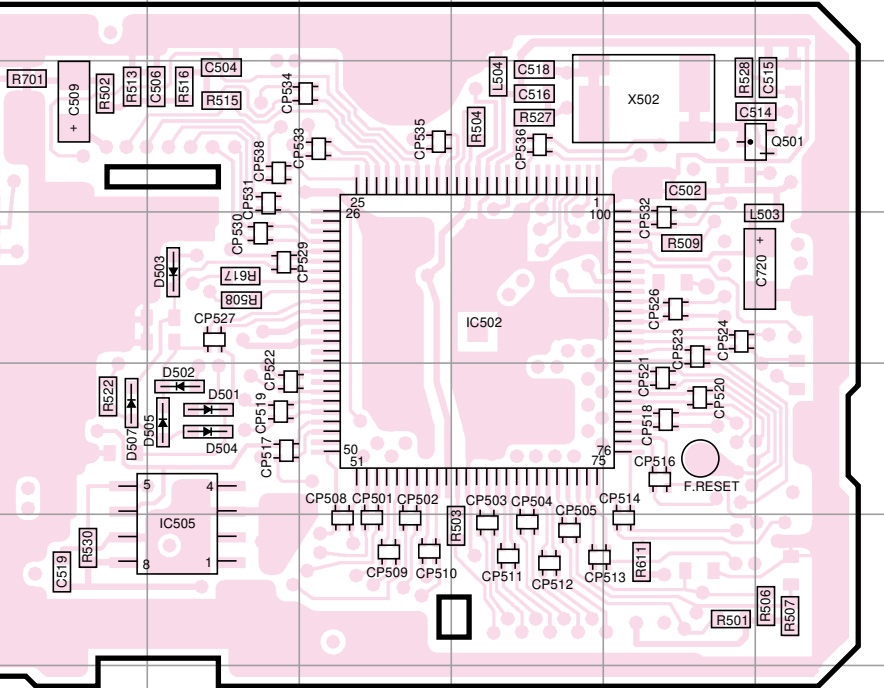

Ref. No.	Address	Ref. No.	Address	Ref. No.	Address	Ref. No.	Address	Ref. No.	Address	Ref. No.	Address	Ref. No.	Address	Ref. No.	Address
IC502	10Q	IC509	11J	Q501	9S	Q504	11C	Q508	11C	D502	11O	D505	11O	D523	11B
IC505	12O	IC511	9E	Q502	11I	Q505	11B	Q509	11C	D503	10O	D507	11N	D524	9B
IC508	11G	IC512	11L	Q503	12J	Q506	11B	D501	11O	D504	11O	D508	9G	D525	10D
								D501	11O	D504	11O	D508	9G	D525	10D

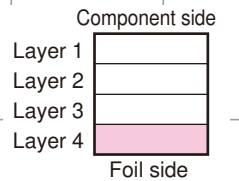

# TK-760G/760HG PC BOARD

TX-RX UNIT (X57-5950-21) (A/2): TK-760G(M)  
Component side view (J79-0200-09)

# PC BOARD TK-760G/760HG

TX-RX UNIT (X57-5950-21) (A/2): TK-760G(M)  
Component side view (J79-0200-09)

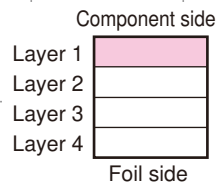

Ref. No.	Address	Ref. No.	Address	Ref. No.	Address	Ref. No.	Address
IC3	10H	IC12	6O	Q11	11G	D25	4M
IC4	12M	IC13	8R	Q12	11G	D26	4O
IC5	12I	IC400	2I	Q35	12L	D34	5E
IC6	10M	Q2	12R	Q37	11L	D37	7D
IC7	9L	Q8	7F	Q38	12R	D40	11M
IC11	10J	Q9	10F	D9	9G	D41	11G

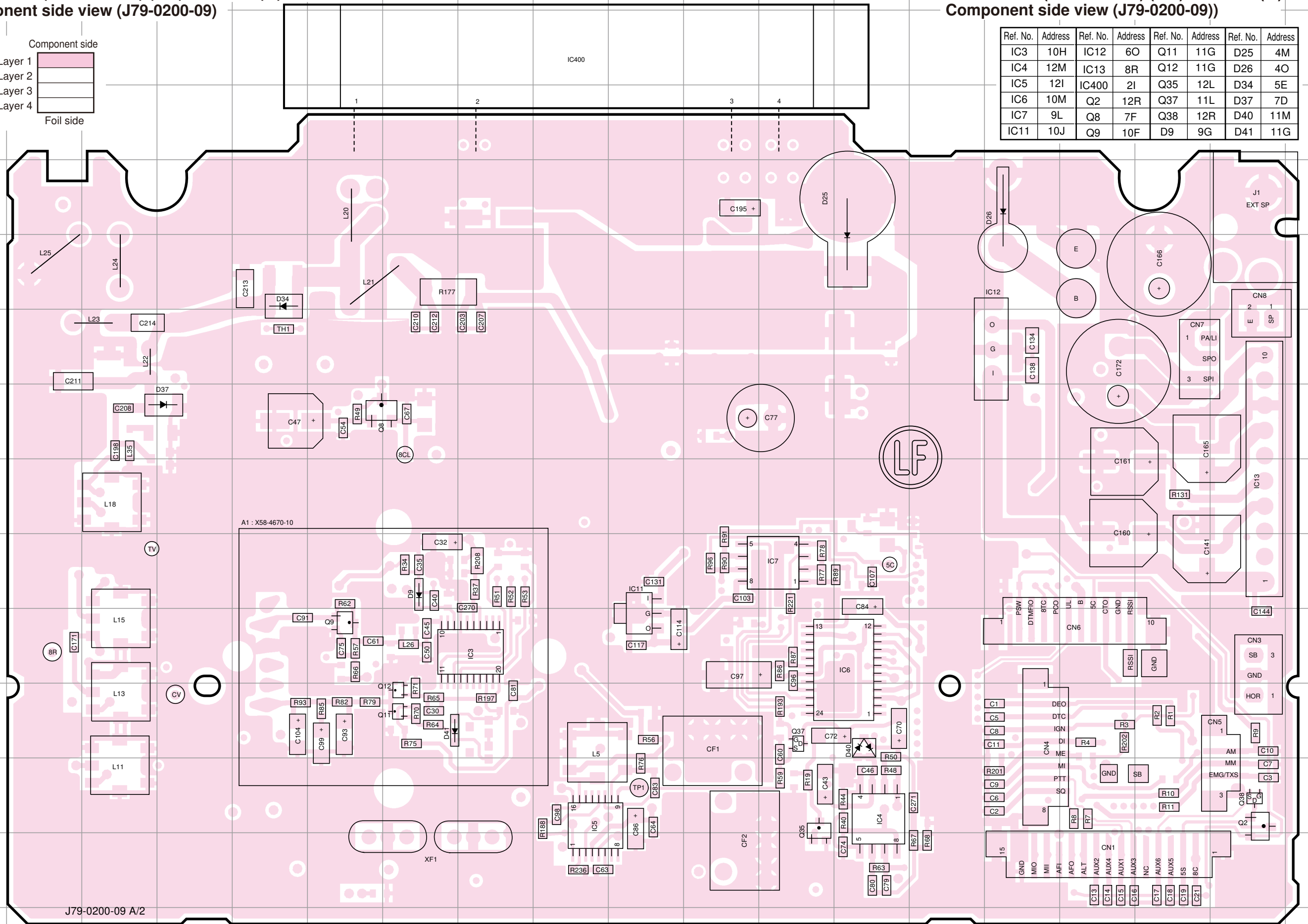

J79-0200-09 A/2

# TK-760G/760HG PC BOARD

TX-RX UNIT (X57-5950-21) (A/2) : TK-760G(M)

Foil side view (J79-0200-09)

# PC BOARD TK-760G/760HG

TX-RX UNIT (X57-5950-21) (A/2) : TK-760G(M)

Foil side view (J79-0200-09)

Ref. No.	Address	Ref. No.	Address	Ref. No.	Address	Ref. No.	Address	Ref. No.	Address	Ref. No.	Address	Ref. No.	Address	Ref. No.	Address
IC1	11E	IC15	7O	Q6	11B	Q16	13M	Q22	7L	Q29	7G	D3	13C	D14	10H
IC2	9J	IC400	2K	Q7	11K	Q17	9B	Q23	7E	Q33	7N	D4	13C	D15	10B
IC8	9N	Q1	11B	Q10	13G	Q18	13N	Q24	8B	Q36	9K	D5	13D	D16	11N
IC9	9G	Q3	12H	Q13	13K	Q19	7C	Q26	8D	Q39	5G	D8	12J	D17	7L
IC10	8E	Q4	12H	Q14	10N	Q20	8C	Q27	9Q	D1	13D	D10	13I	D18	12Q
IC14	9D	Q5	11B	Q15	13O	Q21	7C	Q28	7I	D2	12B	D11	12G	D19	8B

Ref. No.	Address	Ref. No.	Address	Ref. No.	Address
D20	8D	D28	10Q	D42	4G
D21	7C	D30	8Q	D43	6G
D22	7J	D31	8Q	D44	5G
D23	10Q	D35	7Q		
D24	8D	D36	6R		
D27	8D	D39	8L		

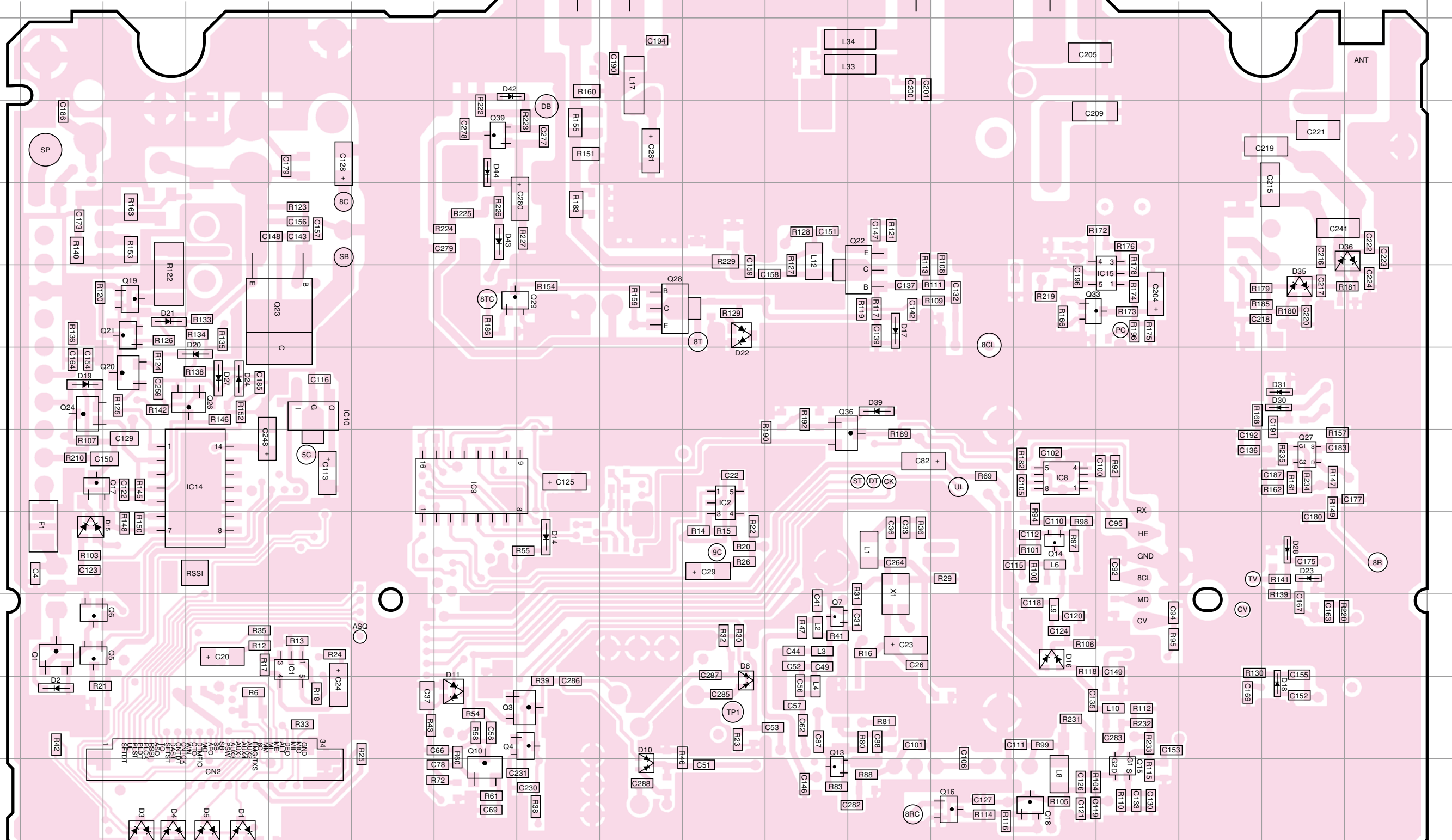
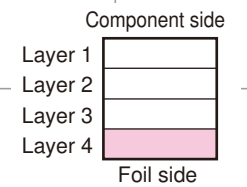



# TK-760G/760HG PC BOARD

TX-RX UNIT (X57-5950-21) (B/2) : TK-760G(M)  
Component side view (J79-0200-09)

# PC BOARD TK-760G/760HG

TX-RX UNIT (X57-5950-21) (B/2) : TK-760G(M)  
Component side view (J79-0200-09)

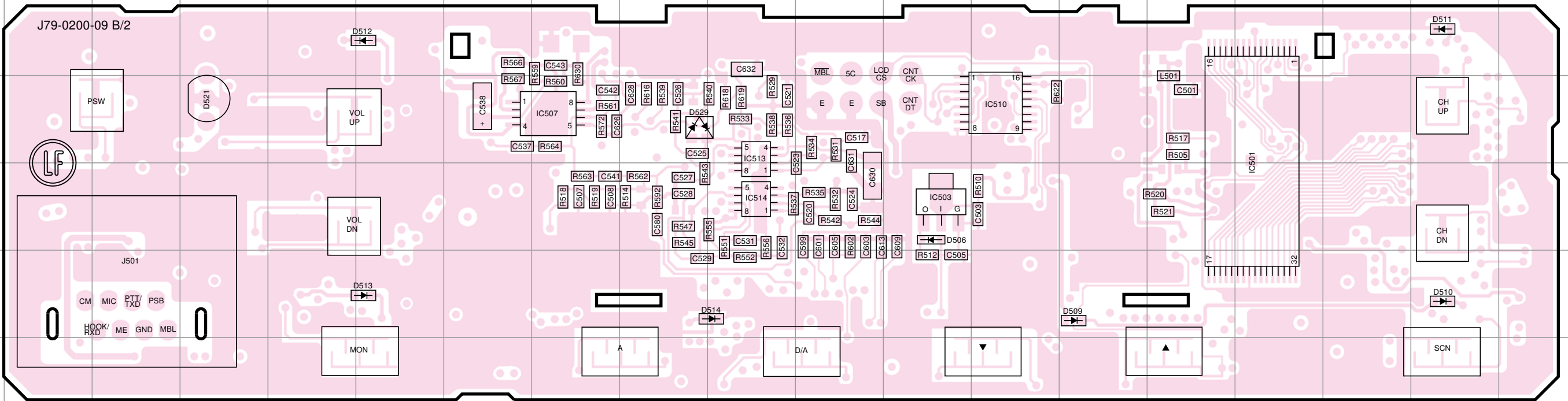

Ref. No.	Address	Ref. No.	Address	Ref. No.	Address	Ref. No.	Address	Ref. No.	Address
IC501	3P	IC510	3M	D506	4L	D511	2R	D514	5J
IC503	4L	IC513	3J	D509	5N	D512	2F	D521	3D
IC507	3H	IC514	4J	D510	5R	D513	5F	D529	3I

## TX-RX UNIT (X57-5950-21) (B/2) : TK-760G(M) Foil side view (J79-0200-09)

## TX-RX UNIT (X57-5950-21) (B/2) : TK-760G(M) Foil side view (J79-0200-09)

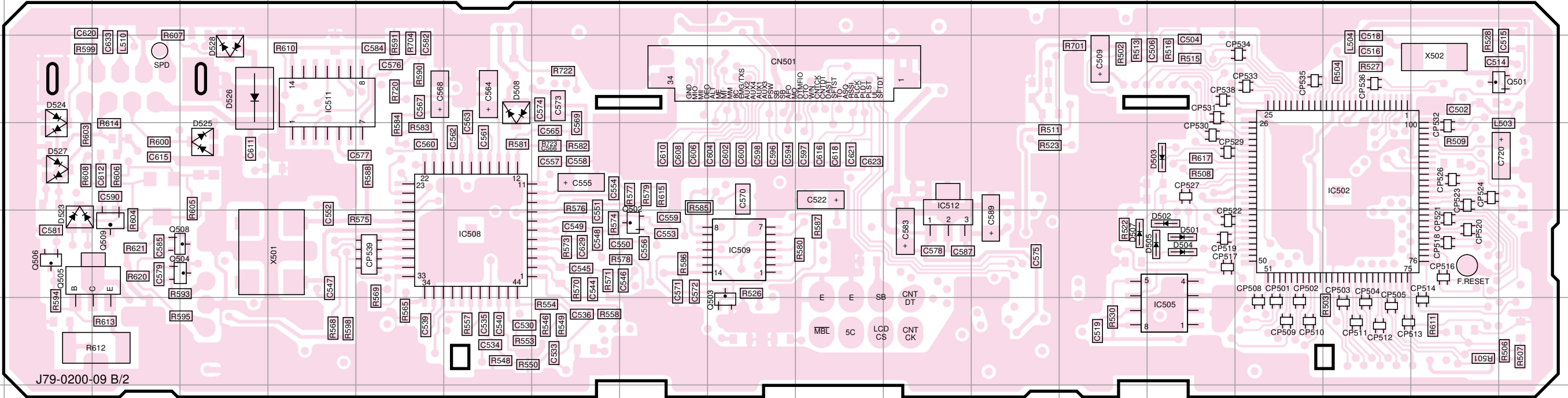

Ref. No.	Address	Ref. No.	Address	Ref. No.	Address	Ref. No.	Address	Ref. No.	Address	Ref. No.	Address	Ref. No.	Address	Ref. No.	Address
IC502	10Q	IC509	11J	Q501	9S	Q504	11C	Q508	11C	D502	11O	D505	11O	D523	11B
IC505	12O	IC511	9E	Q502	11I	Q505	11B	Q509	11C	D503	10O	D507	11N	D524	9B
IC508	11G	IC512	11L	Q503	12J	Q506	11B	D501	11O	D504	11O	D508	9G	D525	10D
														D526	9D
														D527	10B
														D528	9D

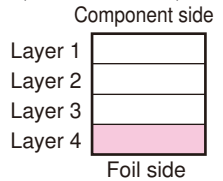

DISPLY UNIT (X54-3270-10)

TX-RX UNIT (X57-5950-XX) (B/2): CONTROL SECTION

TX-RX UNIT (X57-5950-XX) (A/2): TX-RX SECTION

VCO UNIT (X58-4670-XX)

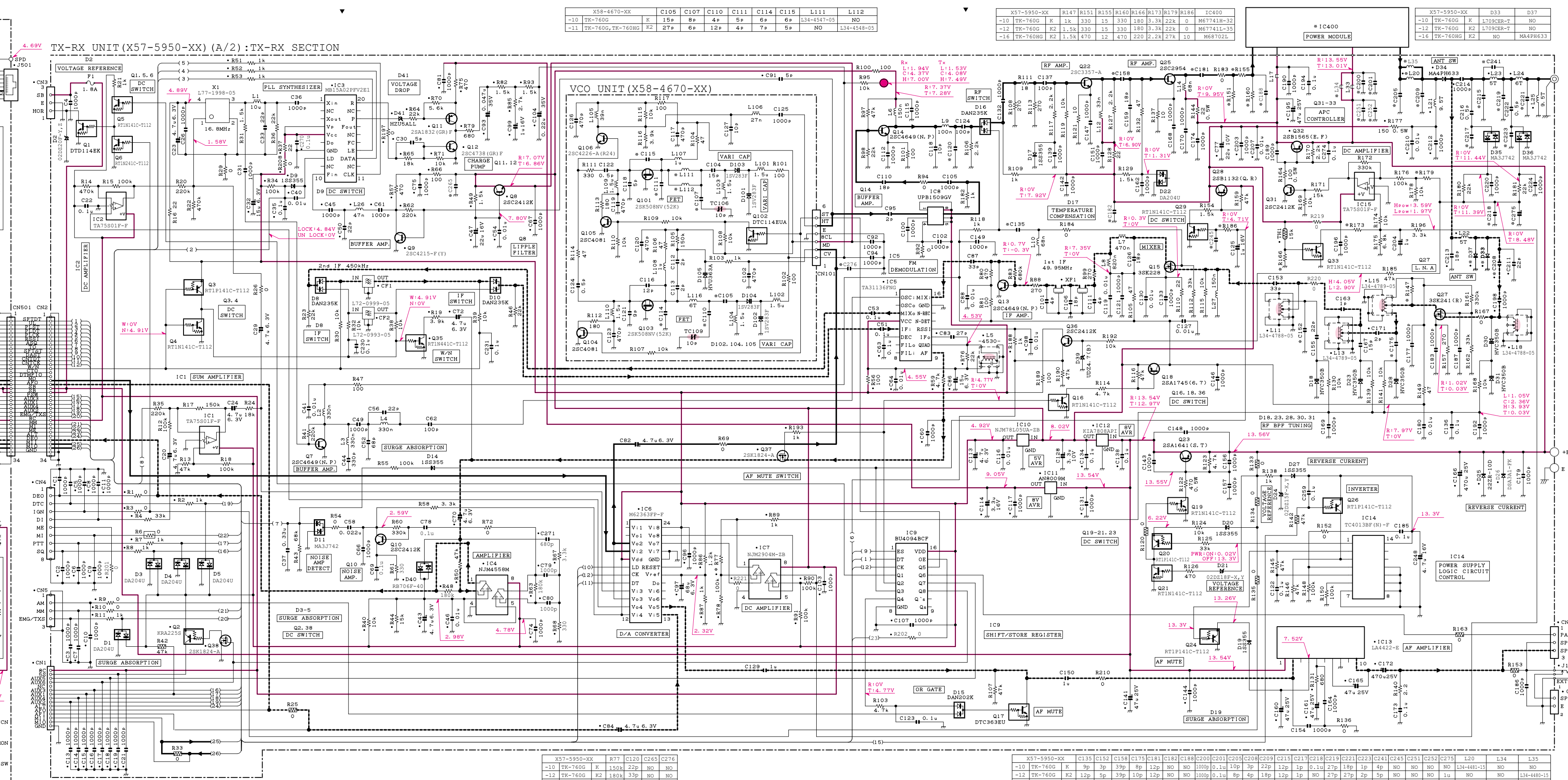
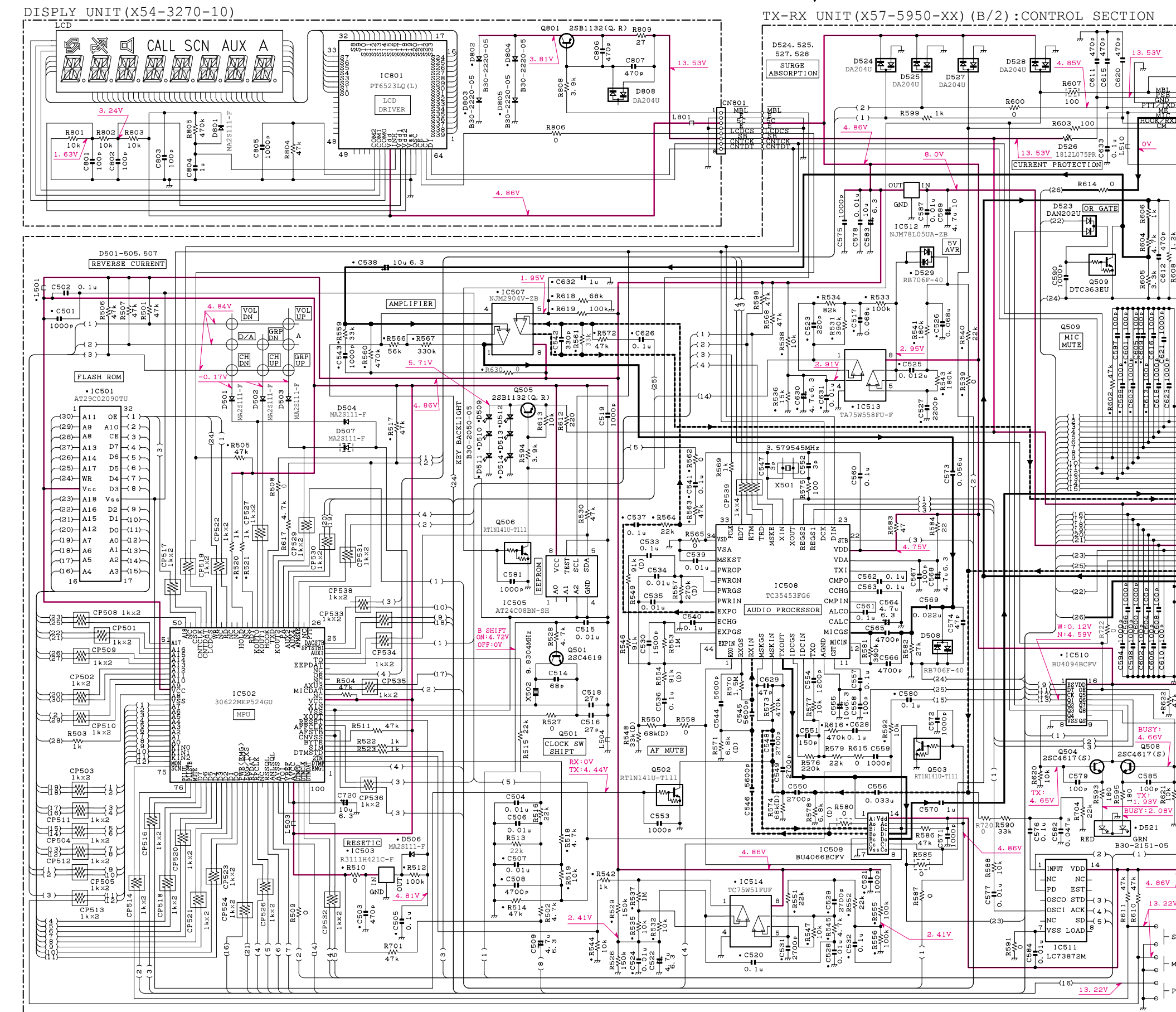

X59-4670-XX	C105	C107	C110	C111	C114	C115	L111	L112
-10 TK-760G	K	15p	8p	4p	5p	6p	NO	NO
-11 TK-760G,TK-760GS	K2	27p	6p	12p	4p	7p	5p	NO

X57-5950-XX	R147	R151	R155	R160	R166	R173	R179	R186	IC400
-10 TK-760G	K	1k	330	15	330	180	3.3k	22k	0
-12 TK-760G	K2	1.5k	330	15	330	180	3.3k	22k	0
-16 TK-760GS	R2	1.5k	470	12	470	220	2.2k	27k	10

X57-5950-XX	D33	D37
-10 TK-760G	K	1709CR-T
-12 TK-760G	K2	1709CR-T
-16 TK-760GS	K2	NO

X57-5950-XX	R77	C120	C245	C274
-10 TK-760G	K	150k	22p	NO
-12 TK-760G	K2	180k	33p	NO
-16 TK-760GS	K2	180k	33p	1000p

X57-5950-XX	C135	C152	C158	C175	C181	C182	C188	C200	C201	C208	C209	C213	C217	C218	C219	C221	C223	C241	C245	C251	C252	C275	L20	L34	L35
-10 TK-760G	K	9p	3p	39p	8p	12p	NO	1000p	0.1u	10p	1p	0.1u	27p	18p	1p	0.1u	27p	2p	1p	NO	NO	NO	NO	NO	NO
-12 TK-760G	K2	12p	5p	39p	12p	NO	NO	1000p	0.1u	9p	4p	18p	12p	1p	0.1u	27p	2p	1p	NO	NO	NO	NO	NO	NO	NO
-16 TK-760GS	K2	12p	5p	22p	10p	39p	1000p	6p	NO	16p	4p	22p	10p	10p	18p	15p	1p	0.1u	1000p	0.1u	NO	NO	NO	NO	NO

