

VHF FM TRANSCEIVER

TK-760G/(N)/762G/(N)

SERVICE MANUAL

5 TONE

KENWOOD

© 2003-2 PRINTED IN JAPAN
B51-8562-10 (N) ***

REVISED

TK-760G/(N)

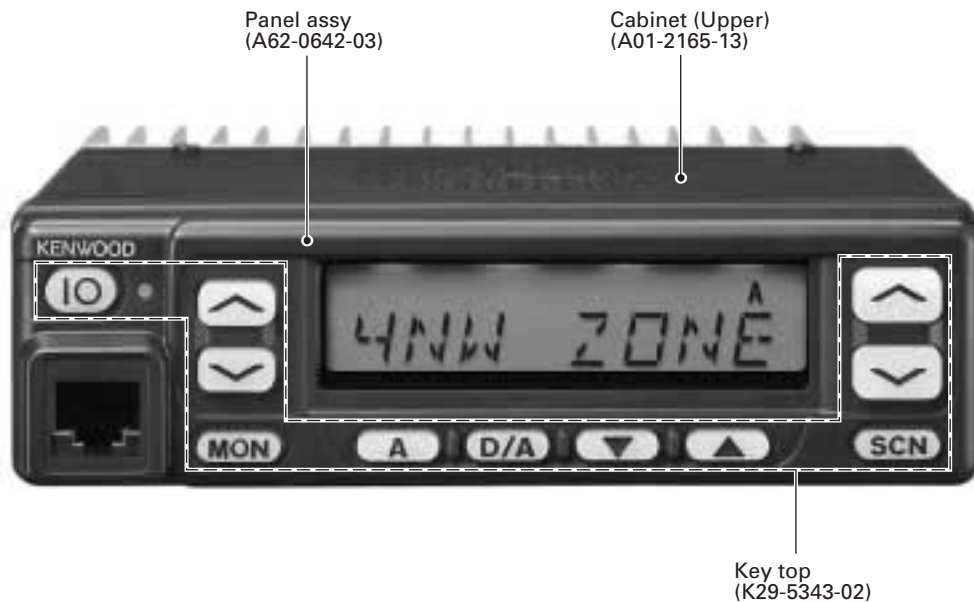

TK-762G/(N)

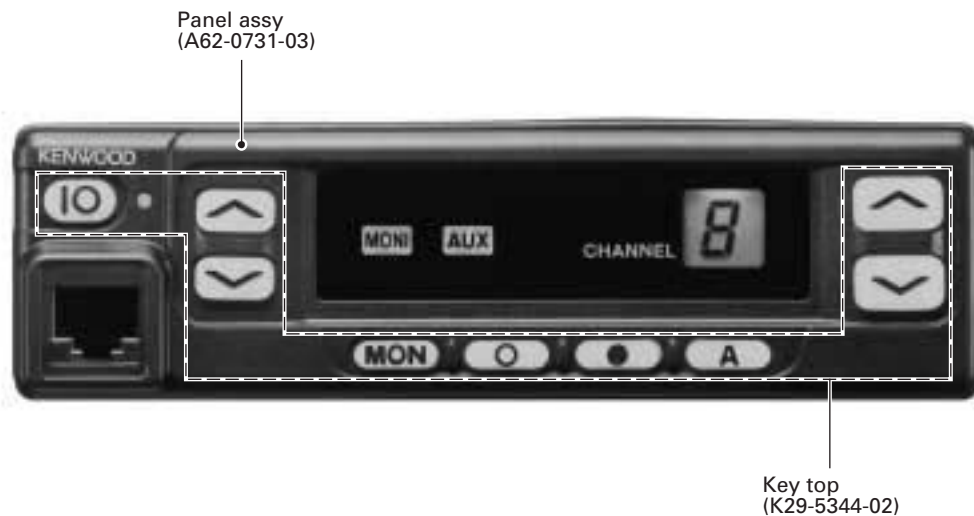

CONTENTS / GENERAL

CONTENTS

GENERAL	2
SYSTEM SET-UP	4
OPERATING FEATURES	5
REALIGNMENT	11
INSTALLATION	18
CIRCUIT DESCRIPTION	24
SEMICONDUCTOR DATA	29
DESCRIPTION OF COMPONENTS	31
PARTS LIST	33
EXPLODED VIEW	42
PACKING	44
ADJUSTMENT	45
PC BOARD VIEWS	
DISPLAY UNIT (X54-3270-10) : TK-760G	54
DISPLAY UNIT (X54-3280-10) : TK-762G	55
PLL/VCO (X58-4670-10)	56
TX-RX UNIT (X57-595X-XX) (A/2)	57
TX-RX UNIT (X57-595X-XX) (B/2)	63
SCHEMATIC DIAGRAM	67
BLOCK DIAGRAM	75
LEVEL DIAGRAM	78
TERMINAL FUNCTION	80
SPECIFICATIONS	81

GENERAL

INTRODUCTION

SCOPE OF THIS MANUAL

This manual is intended for use by experienced technicians familiar with similar types of commercial grade communications equipment. It contains all required service information for the equipment and is current as of the publication date. Changes which may occur after publication are covered by either Service Bulletins or Manual Revisions. These are issued as required.

ORDERING REPLACEMENT PARTS

When ordering replacement parts or equipment information, the full part identification number should be included. This applies to all parts : components, kits, or chassis. If the part number is not known, include the chassis or kit number of which it is a part, and a sufficient description of the required component for proper identification.

PERSONNEL SAFETY

The following precautions are recommended for personnel safety :

- DO NOT transmit if someone is within two feet (0.6 meter) of the antenna.
- DO NOT transmit until all RF connectors are verified secure and any open connectors are properly terminated.
- SHUT OFF and DO NOT operate this equipment near electrical blasting caps or in an explosive atmosphere.
- All equipment should be properly grounded before power-up for safe operation.
- This equipment should be serviced by a qualified technician only.

Note

The terms, "Wide" and "Semi wide" this service manual, are same as "W5k" and "W4k" in the KPG-67D (Field Programming Unit) menu and help text, respectively.

PRE-INSTALLATION CONSIDERNATIONS

1. UNPACKING

Unpack the radio from its shipping container and check for accessory items. If any item is missing, please contact KENWOOD immediately.

GENERAL

2. PRE-INSTALLATION CHECKOUT

2-1. Introduction

Each radio is adjusted and tested before shipment. However, it is recommended that receiver and transmitter operation be checked for proper operation before installation.

2-2. Testing

The radio should be tested complete with all cabling and accessories as they will be connected in the final installation. Transmitter frequency, deviation, and power output should be checked, as should receiver sensitivity, squelch operation, and audio output. Signalling equipment operation should be verified.

3. PLANNING THE INSTALLATION

3-1. General

Inspect the vehicle and determine how and where the radio antenna and accessories will be mounted.

Plan cable runs for protection against pinching or crushing wiring, and radio installation to prevent overheating.

3-2. Antenna

The favored location for an antenna is in the center of a large, flat conductive area, usually at the roof center. The trunk lid is preferred, bond the trunk lid and vehicle chassis using ground straps to ensure the lid is at chassis ground.

3-3. Radio

The universal mount bracket allows the radio to be mounted in a variety of ways. Be sure the mounting surface is adequate to support the radio's weight. Allow sufficient space around the radio for air cooling. Position the radio close enough to the vehicle operator to permit easy access to the controls when driving.

3-4. DC Power and wiring

1. This radio may be installed in negative ground electrical systems only. Reverse polarity will cause the cable fuse to blow. Check the vehicle ground polarity before installation to prevent wasted time and effort.
2. Connect the positive power lead directly to the vehicle battery positive terminal. Connecting the Positive lead to any other positive voltage source in the vehicle is not recommended.
3. Connect the ground lead directly to the battery negative terminal.
4. The cable provided with the radio is sufficient to handle the maximum radio current demand. If the cable must be extended, be sure the additional wire is sufficient for the current to be carried and length of the added lead.

4. INSTALLATION PLANNING – CONTROL STATIONS

4-1. Antenna system

Control station. The antenna system selection depends on many factors and is beyond the scope of this manual. Your KENWOOD dealer can help you select an antenna system that will best serve your particular needs.

4-2. Radio location

Select a convenient location for your control station radio which is as close as practical to the antenna cable entry point. Secondly, use your system's power supply (which supplies the voltage and current required for your system). Make sure sufficient air can flow around the radio and power supply to allow adequate cooling.

SERVICE

This radio is designed for easy servicing. Refer to the schematic diagrams, printed circuit board views, and alignment procedures contained in this manual.

Note

When you modify your radio as described in system set-up, take the following precaution.

The rating of pin 7 (SB) of the accessory connector cable (KCT-19) on the rear of the radio is 13.2V (1A). Insert a 1A fuse if you use the SB pin for external equipment.

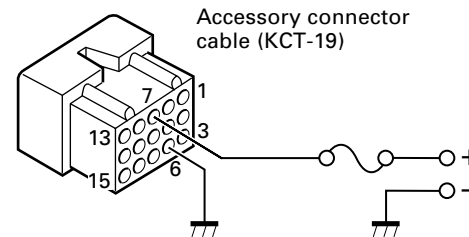

If you do not intend to use the 3.5-mm jack for the external speaker, fit the supplied speaker-jack cap (B09-0235-05) to stop dust and sand getting in.

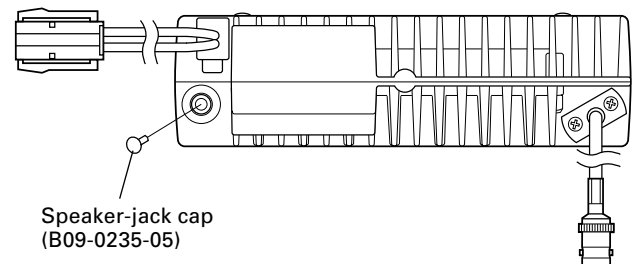

TK-760/G(N)/762G/(N)

SYSTEM SET-UP

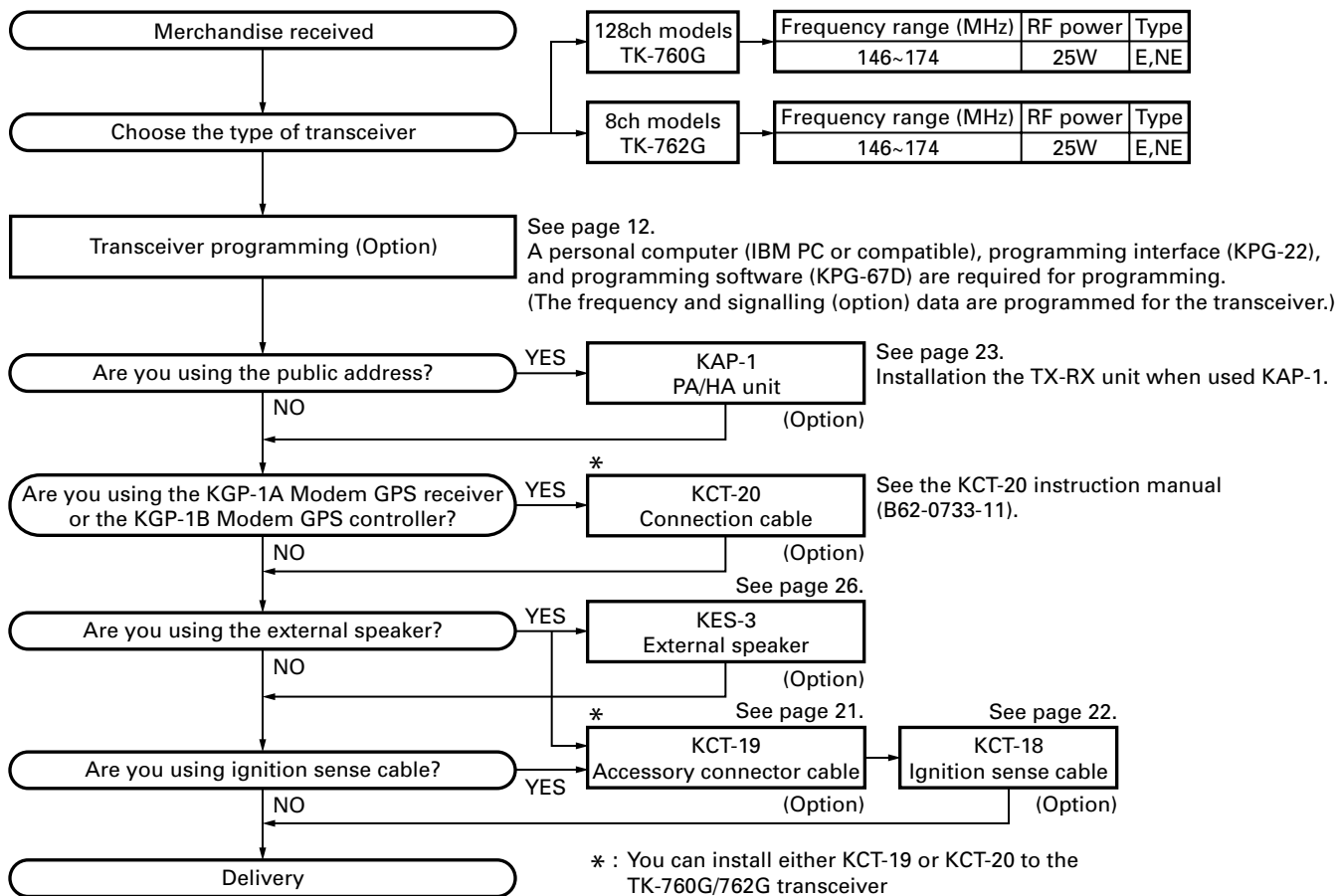

OPERATING FEATURES

1. Controls and Functions

1-1. TK-760G Front Panel

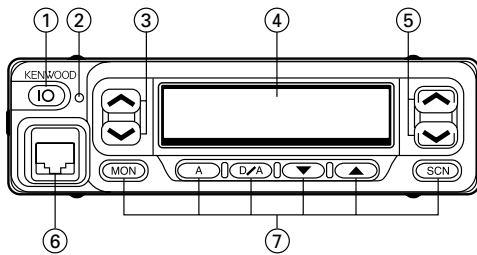

1-2. TK-762G Front Panel

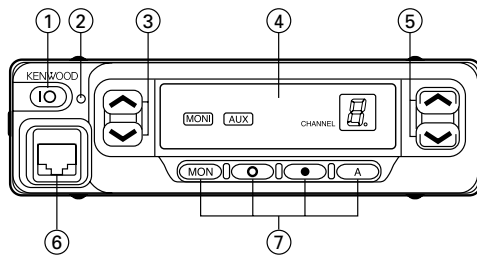

1-3. Speaker/Microphone

■ Optional KMC-30

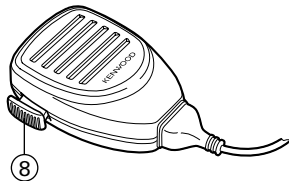

- ① IO (Power) switch
Press to switch the transceiver ON (or OFF).
- ② LED indicator
Lights red while transmitting. Lights green while receiving. If programmed by the dealer, flashes orange while receiving a Code Squelch or Selective Call code, or a 2-Tone code that matches the one set up in your transceiver.
- ③ ▲/▼ keys
These are PF (Programmable Function) keys. Press each key to activate its auxiliary function. The default settings are Volume Up and Volume Down.
- ④ Display
See right.
- ⑤ ▲/▼ keys
These are PF (Programmable Function) keys. Press each key to activate its auxiliary function. The default settings are Channel Up and Channel Down.
- ⑥ Microphone jack
Insert the microphone plug into this connector.
- ⑦ MON, A, D/A, ▼, ▲, and SCN keys (TK-760G)
MON, ○, ●, and A keys (TK-762G)
These are PF (Programmable Function) keys. Press each key to activate its auxiliary function.
- ⑧ PTT (Push-to-Talk) switch
Press this switch, then speak into the microphone to call a station.

1-4. Display

■ TK-760G

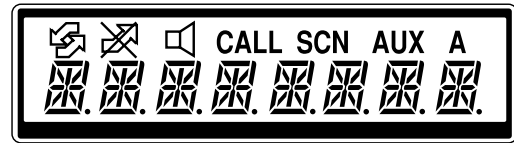

Indicator	Description
	Not used in this transceiver.
	Appears when the selected channel is busy.
	Appears when QT, DQT, DTMF, 2-Tone, or 5-tone decoding is deactivated (by pressing the Monitor or Squelch key).
CALL	If programmed by your dealer, appears when you receive a Code Squelch, Selective Call, 2-Tone code, 5-Tone code. Also appears when you transmit using Code Squelch or Selective Call.
SCN	Appears while scanning.
AUX	Appears when the AUX port is activated.
A	Appears when the selected channel is included in the scanning sequence.
	Displays the selected channel number (or name), DTMF digits (when entering digits, confirming digits, or making a call), and messages received via Selective Call.

■ TK-762G

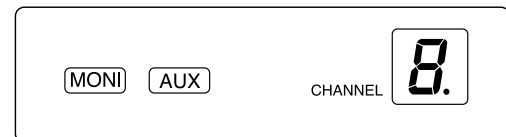

Indicator	Description
MONI	Appears when QT, DQT, DTMF, 2-Tone, or 5-Tone decoding is deactivated (by pressing the Monitor or Squelch key).
AUX	Appears when the AUX port is activated. Flashes orange when the Talk-Around feature is active.
	Displays the selected channel number.

TK-760/G(N)/762G/(N)

OPERATING FEATURES

1-5. Rear panel

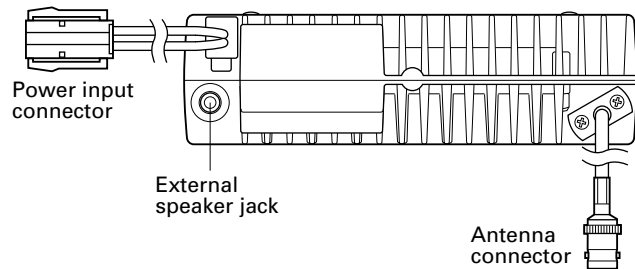

1-6. Programmable Auxiliary Functions

The following keys can be programmed with the functions listed below.

TK-760G : \swarrow/\searrow (left side), \nearrow/\nwarrow (right side), MON, A, D/A, ∇ , \blacktriangle , and SCN.

TK-762G : \swarrow/\searrow (left side), \nearrow/\nwarrow (right side), MON, \circ , \bullet , and A.

Function	DTMF/2-Tone	5-Tone
AUX	Yes	Yes
Call 1	No	Yes
Call 2	No	Yes
Channel Down	Yes	Yes
Channel Up	Yes	Yes
Display Character (TK-760G only)	Yes	Yes
Group Down	Yes	Yes
Group Up	Yes	Yes
Home Channel	Yes	Yes
Horn Alert	Yes	Yes
Key Lock	Yes	Yes
Monitor	Yes	Yes
Monitor Momentary	Yes	Yes
None (No function)	Yes	Yes
Public Address	Yes	Yes
Redial	Yes	No
Scan (TK-760G only)	Yes	Yes
Scan Del/Add (TK-760G only)	Yes	Yes
Selcall Entry	No	Yes
Squelch Momentary	Yes	Yes
Squelch Off	Yes	Yes
Talk-Around	Yes	Yes
Volume Up	Yes	Yes
Volume Down	Yes	Yes
2-Tone Encode*	Yes	No

* : The code for the TK-762G transceiver is not selectable. You can transmit only one 2-Tone code, which is pre-programmed in the transceiver.

The Emergency function can also be programmed. However, it can only be used with a foot switch.

2. Operation Features

The TK-760G/762G is a VHF FM radio designed to operate in conventional format. The programmable features are summarized.

3. Transceiver Controls and Indicators

3-1. Front Panel Controls

All the keys on the front panel are momentary-type push buttons. The functions of these keys are explained below.

- **POWER key**

Transceiver POWER key. When the power is switched off, all the parameters are stored in memory. When the power is switched on again, the transceiver returns to the previous conditions.

- **CHANNEL UP/DOWN key (Programmable)**

- **$\blacktriangle/\blacktriangledown$ key (Programmable) : TK-760G only**

- **SCAN key (Programmable) : TK-760G only**

- **MONITOR key (Programmable)**

- **A, D/A key (Programmable) : TK-760G only**

- **\circ, \bullet, A key (Programmable) : TK-762G only**

- **VOLUME UP/DOWN key (Programmable)**

- **BUSY/TX LED**

The BUSY indicator (Green LED) shows that the channel is in use. The TX indicator (Red LED) shows that you are transmitting.

3-2. Programmable Keys

The FPU (KPG-67D) enables programmable keys to select the following functions.

AUX, Channel down, Channel up, Display character *1, Emergency (Only foot key), Group down *1, Group up *1, Home channel, Horn alert, Key lock, Squelch Momentary, Squelch Off, Monitor Momentary, Monitor, Public address, Redial, Scan *1, Scan del/add *1, Talk around, Volume down, Volume up, 2-tone encode and None.

These functions the FPU programs to the function keys and described in the following sections.

*1 : TK-760G only.

- **AUX**

If this key is pressed, "AUX" icon lights on the display and AUX port which is inside of the transceiver turns to the high level. If pressed again, the "AUX" icon goes off and the AUX ports turns to the lower level.

- **Channel up/down**

When the key is pressed each time, the channel number to be selected is incremented/decremented and repeats if held for one second or longer.

OPERATING FEATURES

- **Display character (TK-760G only)**

This key switches the LCD display between the group and channel number and the group and channel name.

- **Emergency**

Pressing this key for longer than 1 second causes the transceiver to enter the emergency mode. The transceiver jumps to the programmed "Emergency the group and channel" and transmits for 25 seconds.

The transceiver disables mic mute while transmitting. After finishing transmission, the transceiver receives for 5 seconds. The transceiver mutes the speaker while receiving. Following the above sequence, the transceiver continues to transmit and receive.

- **Emergency mode system chart (TK-760G)**

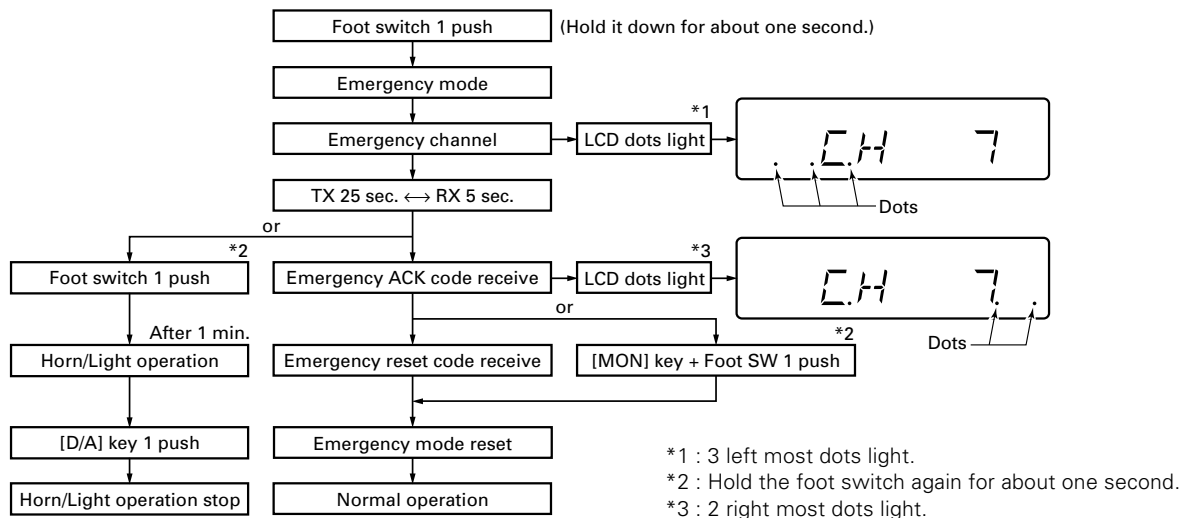

- **Emergency mode system chart (TK-762G)**

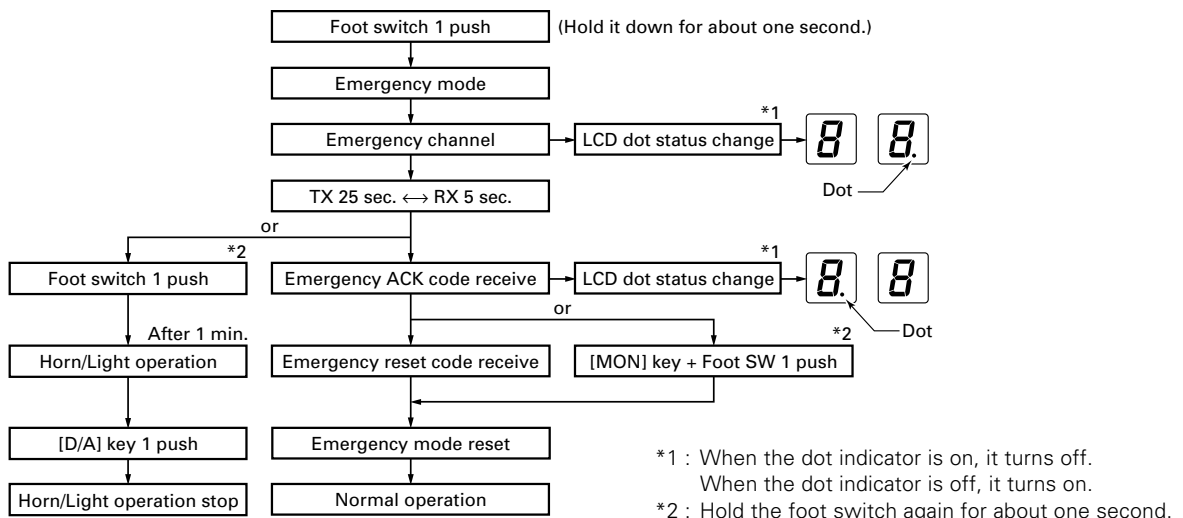

OPERATING FEATURES

- **Group up/down (TK-760G only)**

When the key is pressed each time, the group number to be selected is incremented/decremented and repeats if held for one second or longer.

- **Home channel**

Press this key once, the channel switches to the pre-programmed home channel.

- **Horn alert**

If you are called from the base station using 2-tone/DTMF while you are away from your transceiver, you will be alerted by the vehicle horn or some other type of external alert. To turn the horn alert function on, press this key. A confirmation tone sounds, (and the display shows "HA" on the LCD *1).

If this key is pressed again, the horn alert function is turned off.

*1 : TK-760G only.

- **Key lock**

Pressing this key causes the transceiver to accept entry of only the [Vol Up/Down], [Key lock], [PTT], [Monitor A], [Monitor B], [Monitor C], [Monitor D], and [Emergency] keys.

- **Monitor**

Used to release signalling or squelch when operating as a conventional. It is also used to reset option signalling.

- **Public address**

Public address amplifies the microphone audio, and outputs it through a PA speaker. PA is activated by pressing this key. A confirmation tone sounds, (and the display shows "PA" *1). PA can be activated at anytime (scanning or non-scanning).

If this key is pressed again, a confirmation tone will sound, (the display will return to the normal channel or SCAN display *1), and the PA function will turn off.

*1 : TK-760G only.

- **Redial**

If you press this key when the group/channel is displayed, the last transmitted DTMF code will appear on the display. Pressing the PTT switch at this time will transmit the displayed DTMF code.

- **Scan (TK-760G only)**

Press this key starts scanning. Pressing this key stops scanning.

- **Scan del/add (TK-760G only)**

This key switches the currently displayed channel between "Delete" and "Add".

The "Add" channel contained in the scan sequence, and "Delete" channel is not contained. In the scan mode, this key switches the channel delete or add temporarily.

- **Talk around**

Press this key, the transceiver uses the receive frequency and the tone for transmission.

The operator can call the other party directory (without repeater). Press this key again, the talk around function goes off.

- **Volume up/down**

When the key is pressed, the volume level is increased/decreased and repeats if held for 200ms or longer.

- **None**

Sounds error operation beep, and no action will occur. Use this function when the transceiver is required to be more simple operated.

- **Call 1 or 2 (5-Tone)**

Press the [CALL #] key to transmit the 5-tone code that is programmed to "Call #" in the channel data.

- **Selcall entry**

Press [Selcall entry] key to enter the desired Selcall code you want to call.

When you enter Selcall entry mode, the "TX address" number appears on the LCD.

To enter Selcall number, use the keypad. You can also use the channel selector to select the number.

4. Scan Operating (TK-760G only)

■ Scan types

- **Single group scan**

You can scan all valid (ADD) channels in the displayed group that can be selected with the group up/down key.

- **Multiple group scan**

You can scan all valid (ADD) channels in the all valid (ADD) group.

■ SCAN start condition

One or more non-priority channels must be added to all channels that can be scanned. The transceiver must be in normal receive mode (PTT off).

When you activate the key programmed to the scan function, the scan starts. The scan icon "SCN" lights and "SCAN" is indicated on alphanumeric display.

■ Scan stop condition

The scan stops temporarily if the following conditions are satisfied.

- 1) A carrier is detected, then signalling matches on channels for which receive the signalling is set by the programming software.
- 2) A carrier is detected on the channels for which receiving signalling is not set by the programming software or when the monitor (signalling cancel) function is activated.

OPERATING FEATURES

■ Scan channel types

- 1) Priority channel is the most important channel for the scan, and always detects a signal during scan and when the scan stops temporarily.
- 2) Non-priority channels detects a signal during scan. For the channels that can be selected with the group or channel up/down key when the scan does not occur, adds an indicator "A" lights.

■ Priority channel setting

A priority channel can be set as follows with the programming software (KPG-67D).

- 1) Specify a priority channel as a fixed priority channel.
- 2) Make a selected channel, a priority channel.

■ Scan type according to the priority channel

- 1) When no priority channel is set : Only the non-priority channels are scanned.
If a non-priority channel stops temporarily, it stops until there is no signal on the channel.
- 2) When priority channel is set : Either priority channel is scanned.
If a non-priority channel stops temporarily, a priority channel signal is detected at certain intervals.
If a priority channel stops temporarily, it stops until there is no signal on the priority channel.

■ Revert channel

The revert channel is used to transmit during scanning and set by the programming software (KPG-67D).

- 1) Priority
The transceiver reverts to the priority channel.
- 2) Priority with talkback
The transceiver reverts to the priority channel.
If you press PTT during a resume timer (dropout delay time, TX dwell time) or calling, you can transmit on current channel to answer to the call however revert channel is set to priority channel.
After resume time, scan re-starts and transmission channel is return to priority channel.
- 3) Selected channel
The transceiver reverts to the channel before scanning or the channel that you changed during scan.
- 4) Last called channel
The transceiver reverts to the last called channel during the scan.
- 5) Last used channel
The transceiver reverts to the last used (transmitted) channel during scan. "Last used" revert channel includes talkback function.
- 6) Selected with talkback
The transceiver reverts to the channel before scanning or the channel that you changed during scan.

■ Scan end

When you reactivate the key programmed to the scan function during scan mode, the scan ends.

The scan icon "SCN" and "SCAN" display goes off.

■ Temporarily delete/add

It is possible to delete or add channel temporarily during scan. When scan stops on unnecessary channel for example by interference of the other party, activate the delete/add function (for example press the key), then that channel is deleted temporarily and scan re-start immediately.

When you would like to add the deleted channel temporarily to scan sequence, select the desired (deleted) channel during scan, activate the delete/add function (for example press the key) before scan re-start.

That channel is added temporarily to scan sequence. The temporary deleted or added channels are returns to pre-set delete/add, when the transceiver exits from scan mode.

5. Details of Features

■ Time-out timer

The time-out timer can be programmed in 15 seconds increments from 15 seconds to ten minutes. If the transmitter is keyed continuously for longer than the programmed time, the transmitter is disabled and a warning tone sounds while the PTT button is held down. The alert tone stops when the PTT button is released.

■ PTT ID

PTT ID provides a DTMF ANI to be sent with every time PTT (beginning of transmission, end of transmission, or both).

You can program PTT ID "on" or "off" for each group. The contents of ID are programmed for each channel.

The timing that the transceiver sends ID is programmable.

BOT : DTMF ID (BOT) is sent on beginning of transmission.

EOT : DTMF ID (EOT) is sent on end of transmission.

Both : DTMF ID (BOT) is sent on beginning of transmission and DTMF ID (EOT) is sent on end of transmission.

■ Radio password (TK-760G only)

When the password is set in the transceiver, user can not use the transceiver unless enter the correct password.

This code can be up to 6 digits from 0 to 9 and input with the key, and "SCN" key.

■ Off hook decode

If the Off hook decode function has been enabled, removing and replacing the microphone on the hook has no effect for decoding QT/DQT and option signalling.

■ "TOT" pre-alert

The transceiver has "TOT" pre-alert timer. This parameter selects the time at which the transceiver generates "TOT" pre-alert tone before "TOT" is expired.

"TOT" will be expired when the selected time passes from a "TOT" pre-alert tone.

OPERATING FEATURES

■ "TOT" re-key time

The transceiver has "TOT" re-key timer. This timer is the time you can not transmit after "TOT" exceeded. After "TOT" re-key time expired you can transmit again.

■ "TOT" reset time

The transceiver has "TOT" reset timer. This timer is the minimum wait time allowed during a transmission that will reset the "TOT" count.

"TOT" reset time causes the "TOT" to continue even after PTT is released unless the "TOT" reset timer has expired.

■ Clear to transpond

The transceiver waits the transpond of 5-tone/2-tone / DTMF if channel is busy until channel open. This feature prevents the interference to other party.

6. Option Signalling (DTMF/2-Tone)

Built-in DTMF decoder is available for option signalling.

Built-in 2-tone decoder is available for option signalling.

It is possible to use individual call, group call, D.B.D. (Dead Beat Disable). D.B.D. is used with DTMF only.

If the option signalling matches, a predetermined action will occur.

If option signalling matches on a group/channel which is set up with option signalling, the option signalling indicator (CALL) will flash and option signalling will be released. The transpond or alert tone will sound.

The orange LED will flash.

While option signalling matches (or if option signalling is deactivated when you are transmitting), you can mute or unmute QT/DQT/Carrier.

■ AND/OR

You can select AND or OR for option signalling match conditions.

	Alert/Transpond
AND	QT/DQT+DTMF (2-tone); Option matches = Action
OR	QT/DQT+DTMF (2-tone); Option matches = Action
	AF mute open
AND	QT/DQT+DTMF (2-tone); Option matches = Action
OR	QT/DQT/ID; Signalling only matches = Action

With OR set up, alert/transpond will not function with only DTMF.

With OR set up, AF mute will not release when only DTMF matches.

With a conventional channel not set up with QT or DQT, only the carrier is considered when signalling matches.

■ Auto Reset

If option signalling matches a group set up with option signalling, option signalling is released. After matching option signalling, option signalling will temporarily reset automatically.

■ Dead Beat Disable

If the D.B.D. code matches, a predetermined action will occur. Whether option signalling is activated or not, when D.B.D. matches on any channel, the transceiver will become TX inhibited or TX/RX inhibited. While D.B.D. is active, if the D.B.D. code + "#" code is received, D.B.D. will deactivate.

When D.B.D. matches, transpond will function. Alert will not be output, and option signalling match icon will not appear.

7. Audible User Feedback Tones

The transceiver outputs various combinations of tones to notify the user of the transceiver operating state. The main tones are listed below.

The high tone is 1477Hz, the mid tone is 941Hz, and the low tone is 770Hz.

■ Power on tone

This tone is output when the transceiver is turned on. (The high tone is output for 500ms.)

■ Alert tone

This tone is output when the transceiver is TX inhibition for TOT, and PLL unlocked. It is output until the PTT button is released.

■ DBD on tone

When a D.B.D. code is received, transpond tone sounds.

■ DBD off tone

When a D.B.D. release code is received, transpond tone sounds.

■ Busy tone

Sounds in conventional mode, when busy channel lock-out is functioning. You can select yes or no for the optional feature's warning tone.

■ Group call tone

Sounds when a group call with the correct DTMF/2-tone option signalling is received, repeats 7 times. You can select yes or no for the optional feature's warning tone.

■ Individual call tone

Sounds when an individual call with the correct DTMF/2-tone option signalling is received. You can select yes or no for the optional feature's warning tone.

■ Key press tone [A]

Sounds when a key is pressed. For toggle keys, sounds when toggle function is turned on (key press tone [B] sounds when it is turned off). You can select yes or no for the optional feature's control tone.

OPERATING FEATURES / REALIGNMENT

■ Key press tone [B]

Sounds when a key is pressed. For toggle keys, sounds when the toggle function is turned off (key press tone [A] sounds when it is turned on). You can select yes or no for the optional feature's control tone.

■ Key input error tone

Sounds when a key is pressed but that key cannot be used. You can select yes or no for the optional feature's warning tone.

■ Roll over tone

Sounds in Conventional format at the smallest group/channel. You can select yes or no for the optional feature's control tone.

■ Transpond tone

Sounds when an individual call with the correct DTMF/2-tone option signalling is received. For group calls, only the group tone will sound, not the transpond tone.

■ Pre alert tone

Sounds prior to the TOT TX inhibit activation. If TOT pre alert is set, the tone sounds at the amount of time programmed, before the TOT expires (TOT time – TOT pre alert time = Pre alert tone sounding time). You can select yes or no for the optional feature's warning tone.

REALIGNMENT

1. Modes

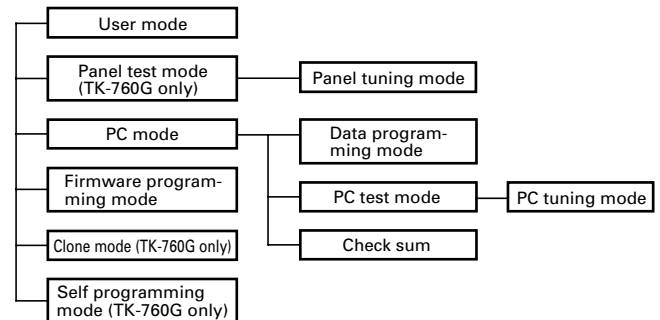

Mode	Function
User mode	For normal use.
Panel test mode	Used by the dealer to check the fundamental characteristics.
Panel tuning mode	Used by the dealer to tune the radio.
PC mode	Used for communication between the radio and PC (IBM compatible).
Data programming mode	Used to read and write frequency data and other features to and from the radio.
PC test mode	Used to check the radio using the PC. This feature is included in the FPU. See panel tuning.
Firmware programming mode	Used when changing the main program of the flash memory.
Clone mode	Used to transfer programming data from one radio to another.
Self programming mode	Frequency, signalling and features write to the radio.

2. How to Enter Each Mode

Mode	Operation
User mode	Power ON
Panel test mode	[SCN]+Power ON (Two seconds)
PC mode	Received commands from PC
Panel tuning mode	[Panel test mode]+[SCN]
Firmware programming mode	[CH ▲]+Power ON (Two seconds)
Clone mode	[▼]+Power ON (Two seconds)
Self programming mode	[A]+Power ON (Two seconds)

3. For the Panel Test Mode (TK-760G only)

Setting method refer to ADJUSTMENT.

3-1. For the Panel Tuning Mode

Setting method refer to ADJUSTMENT.

TK-760G/(N)/762G/(N)

REALIGNMENT

4. Check Sum

Executing this function, "TUNING" appears on the display of the TK-760G while calculation the check sum.

When the calculation is completed, the display returns to normal and PC displays the check sum of the radio.

5. PC Mode

5-1. Preface

The TK-760G/762G transceiver is programmed using a personal computer, a programming interface (KPG-46) and programming software (KPG-67D).

The programming software can be used with an IBM PC or compatible. Figure 1 shows the setup of an IBM PC for programming.

5-2. Connection Procedure

1. Connect the TK-760G/762G to the personal computer with the interface cable.
2. When the Power is switched on, user mode can be entered immediately. When the PC sends a command, the radio enters PC mode.
When data is transmitted from transceiver, the red LED blink.
When data is received by the transceiver, the green LED blink.

Notes :

- The data stored in the personal computer must match model type when it is written into the flash memory.
- Change the TK-760G/762G to PC mode, then attach the interface cable.

5-3. KPG-46 Description

(PC programming interface cable : Option)

The KPG-46 is required to interface the TK-760G/762G with the computer. It has a circuit in its D-subconnector (25-pin) case that converts the RS-232C logic level to the TTL level.

The KPG-46 connects the modular microphone jack of the TK-760G/762G to the computers RS-232C serial port.

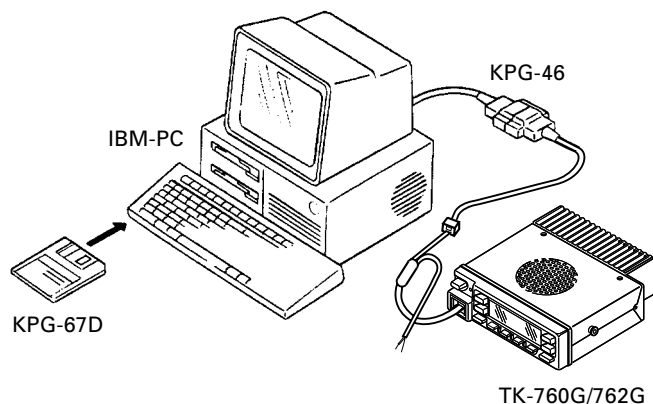

Fig. 1

5-4. Programming Software KPG-67D Description

The KPG-67D is programming software for the transceiver supplied on two 3.5" floppy disks. This software runs under MS-DOS 3.1 or later on an IBM-PC or compatible machine.

The data can be input to or read from the transceiver and edited on the screen. The programmed or edited data can be printed out. It is also possible to tune the transceiver.

We recommend that install the KPG-67D for example to harddisk first then use it.

6. Firmware Programming Mode

6-1. Preface

Flash memory is mounted on the TK-760G/762G. This allows the TK-760G/762G to be upgraded when new features are released in the future. (For details on how to obtain the firmware, contact Customer Service.)

6-2. Connection Procedure

Connect the TK-760G/762G to the personal computer (IBM PC or compatible) with the interface cable (KPG-46). (Connection is the same as in the PC Mode.)

6-3. Programming

1. Start up the programming software (KPG-67D), select "firmware program" in the "Program" item, and press the Return key on your personal computer. This starts up the firmware programmer.
2. The top screen is displayed. Press any key to advance to the next screen.
3. Set the communications speed (normally, 57600 bps) and communications port in the Setup item.
4. Set the firmware to be updated by File select (=F1).
5. Turn the TK-760G/762G Power ON with the [CH \wedge] switch held down. Hold the switch down for two seconds until the display changes to "PROG 576", the BUSY/TX LED lights orange. When "PROG 576" appears, release your finger from the switch.
6. Check the connection between the TK-760G/762G and the personal computer, and make sure that the TK-760G/762G is in Program mode.
7. Press F10 on the personal computer. A window opens on the display to indicate the writing progress. When the TK-760G/762G starts to receive data, the BUSY/TX LED lights green.
8. If writing ends successfully, the LED on the TK-760G/762G goes off and the checksum is displayed. (Since the TK-762G does not have a display, check the checksum with the FPU (KPG-67D).)
9. If you want to continue programming other TK-760G/762G, repeat steps 5 to 8.

REALIGNMENT

Notes :

- To start the Firmware Programmer from KPG-67D, the FPRO path must be set up by the KPG-67D setup.
- This mode cannot be entered if the Firmware programming mode is set to Disable in the Programming software (KPG-67D).
- When programming the firmware, it is recommend to copy the data from the floppy disk to your hard disk before you update the radio firmware.
Directly copying from the floppy disk to the radio may not work because the access speed is too slow.

6-4. Function

1. If you press the [MON] switch while "PROG 576" is displayed, the checksum is displayed. If you press the [MON] switch again (while the checksum is displayed), "PROG 576" is redisplayed.
2. If you press the [A] switch while "PROG 576" is displayed, the display changes to "PROG 192" to indicate that the write speed is low speed (19200 bps). If you press the [A] switch again while "PROG 192" is displayed, the display changes to "PROG 384", and the write speed becomes the middle speed (38400 bps). If you press the [A] switch again while "PROG 384" is displayed, the display returns to "PROG 576".

Note :

TK-762G indicate
 19200 bps : The LED flashes green and red alternately.
 38400 bps : The LED flashes orange.
 57600 bps : The LED lights orange.
 Normally, write in the high-speed mode.

7. Clone Mode (TK-760G only)

Programming data can be transferred from one radio to another by connecting them via their modular microphone jacks. The operation is as follows (the transmit radio is the master and the receive radio is the slave).

1. Turn the master TK-760G power ON with the [▼] key held down. If the password is set to the TK-760G, the TK-760G displays "CLN LOCK". If the password is not set, the TK-760G displays "CLONE".
2. When "CLN LOCK" is displayed, only the [CH▲/▼] key and [SCN], and [0] to [9] keys can be accepted. When you enter the correct password, and "CLONE" is displayed, the TK-760G can be used as the cloning master. The following describes how to enter the password.
3. How to enter the password with the microphone keypad; If you press a key while "CLN LOCK" is displayed, the number that was pressed is displayed on the TK-760G. Each press of the key shifts the display in order to the left. When you enter the password and press the [SCN] key, "CLONE" is displayed if the entered password is correct. If the password is incorrect, "CLN LOCK" is redisplayed.
How to enter the password with the [CH▲/▼] key; If the [CH▲/▼] key is pressed while "CLN LOCK" is displayed, numbers (0 to 9) are displayed flashing. When

you press the [SCN] key, the correctly selected number is determined, and the display shifts to the left. If you press the [SCN] key after entering the password in this procedure, "CLONE" is displayed if the entered password is correct. If the password is incorrect, "CLN LOCK" is redisplayed.

4. Power on the slave TK-760G.
5. Connect the cloning cable (No. E30-3382-05) to the modular microphone jacks on the master and slave.
6. Press the [SCN] key on the master while the master displays "CLONE". The data of the master is sent to the slave. While the slave is receiving the data, "-PC-" is displayed. When cloning of data is completed, the master displays "END", and the slave automatically operates in the User mode. The slave can then be operated by the same program as the master.
7. The other slave can be continuously cloned. When the [SCN] key on the master is pressed while the master displays "END", the master displays "CLONE". Carry out the operation in step 4 to 6.

Note :

You can clone the programmed data between the transceiver frequency version must be same.

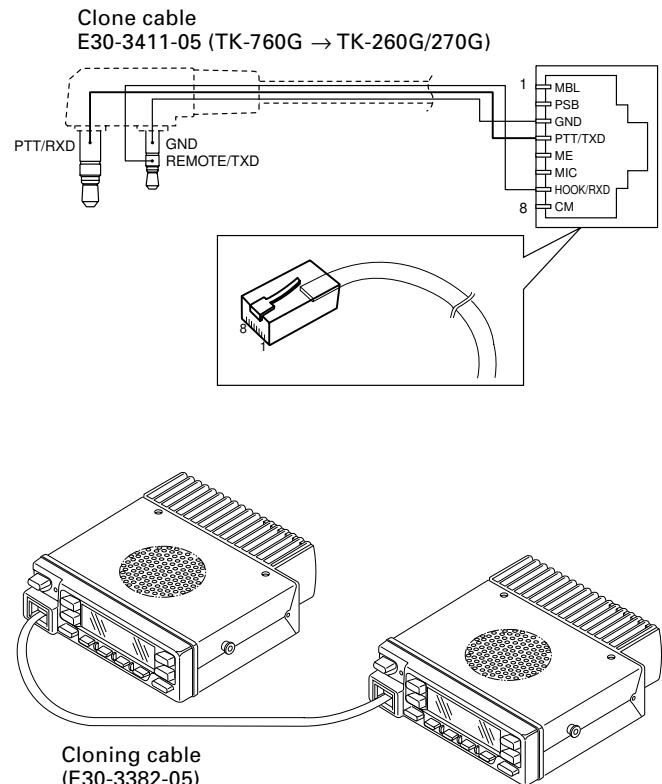

Fig. 2

8. Self Programming Mode (TK-760G only)

Write mode for frequency data and signalling etc. Mainly used by the person maintaining the user equipment.

REALIGNMENT

8-1. Enter to the Self Programming Mode

Remove D507 (Figure 3) from the TX-RX unit. Hold down the [A] key and turn the power switch on. When enter the self programming mode, "SELF" is displayed. The mode changes autoically to Model Select Mode in about one second, and set up radio type, radio band & channel type and frequency version.

Note :

This mode (self programming mode) cannot be set when it has been disabled with the FPU.

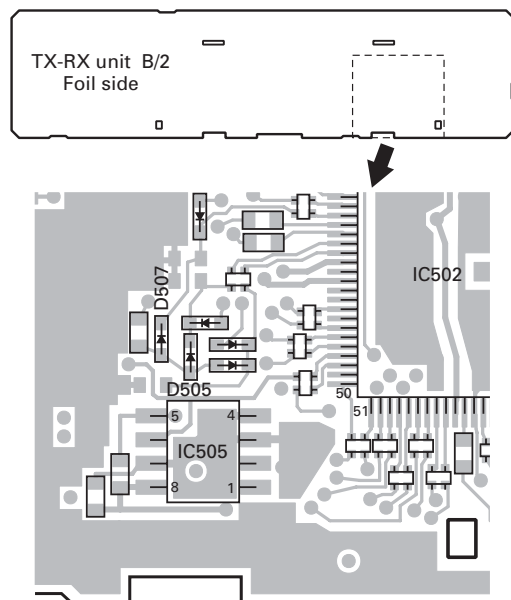

Fig. 3

9. Channel Setting Mode

Each channel can be setup in its action mode by using the panel keys.

- Pressing [MON] when "SELF" is diplayed, sets channel setting mode.
- Select an item set using [▼] then change the selection with the [CH▲/▼].
- The data displayed using [D/A] is stored in the memory and then proceeds to the next item.
- Pressing [▼] proceeds to the next item without storing it in the memory.
- Press [MON] to set the display to "SELF" and return to reset (default) status.

The setup items for channel setting mode are listed below.

No.	Function	Choices	Display	Remarks
	Select channel	1~128	__1-__1__ __1-128__	[▼] : Group selection/ Channel selection change
	Select group	1~128	__1-__1__ 128-__1__	
1	RX frequency	Step 2.5kHz~1MHz	STP__250 STP__1M	Display when an item is selected or when a step is changed (about 0.5 seconds) [A] : Step change 5.0, 6.25kHz, 1MHz step
		Blank	R. - - - - -	
		100.0000~ 550.0000MHz	R.150.0000	[▲] : Frequency on/ blank switching The right most dot indicates 50Hz digit (On=5, Off=0)
2	RX signalling	Off	- - - - -	[▲] : Off/QT/DQT switching [A] : Mode switching [SCN] : Normal/ Inverse switching
		QT 67.0~250.3Hz (EIA mode)	QT__67.0__ QT__250.3__	
		QT 67.0~254.1Hz (0.1Hz step mode)	QT__67.0* QT__254.1*	
		DQT 000~777 (Normal) (1 step mode)	DQT000N* DQT777N*	
		DQT 023~754 (Normal) (Standard table mode)	DQT023N_ DQT754N_	
		DQT 000~777 (Inverse) (1 step mode)	DQT000I* DQT777I*	
		DQT 023~754 (Inverse) (Standard table mode)	DQT023I_ DQT754I_	
3	TX frequency	Step 2.5kHz~1MHz	STP__250 STP__1M	Display when an item is selected or when a step is changed (about 0.5 seconds) [A] : Step change 5.0, 6.25kHz, 1MHz step

REALIGNMENT

No.	Function	Choices	Display	Remarks
		Blank	T.-----	[▲] : Frequency on/ blank switching The right most dot indicates 50Hz digit (On=5, Off=0)
		100.0000~ 550.0000MHz	T.150.0000	
4	TX signalling	Off	-----	[▲] : Off/QT/DQT switching [A] : Mode switching [SCN] : Normal/ Inverse switching
		QT 67.0~250.3Hz (EIA mode)	QT__67.0_ QT_250.3_	
		QT 67.0~254.1Hz (0.1Hz step mode)	QT__67.0* QT_254.1*	
		DQT 000~777 (Normal) (1 step mode)	DQT000N* DQT777N*	
		DQT 023~754 (Normal) (Standard table mode)	DQT023N_ DQT754N_	
		DQT 000~777 (Inverse) (1 step mode)	DQT000I* DQT777I*	
		DQT 023~754 (Inverse) (Standard table mode)	DQT023I_ DQT754I_	
		5	Option signal- ling (Only when DTMF/ 2-tone is se- lected for sig- nalling type)	
		DTMF	DTMF__	
		2-TONE	2TONE__	
6	ID (Only when DTMF is selected for sig- nalling type)	000~ 9999999999	__ID__	Display when an item is selected (about 0.5 seconds)
			12345678	Display of the current setting (If it is 8 or more digits, scroll it)
			----- 987	Display when a code is input (Input it with DTMF key)
			Clear	----- 000
7	Busy channel lockout	No	BCL_NO__	←Default
		Type 1	BCL_1__	
		Type 2	BCL_2__	
8	Beat shift	No	SHFT_NO_	←Default
		Yes	SHFT_YES	
9	RF power	High power	PWR_H__	←Default
		Low power	PWR_L__	
10	Wide/ Narrow (Wide 5k/ Wide 4k)	Wide (Wide 5k)	WIDE__ (WIDE_5K_)	() : E type NE : Not used
		Narrow (Wide 4k)	NARROW_ (WIDE_4K_)	
11	Scan Delete/Add	DELETE	SCAN_DEL	Not used for 8ch
		ADD	SCAN_ADD	←Default

No.	Function	Choices	Display	Remarks
12	Priority channel	No	P.CH_NO__	Not used when (Scan) priority is not fixed
		Yes	P.CH_YES_	
13	Home channel	No	H.CH_NO__	Not used when home channel is not set in key assignment
		Yes	H.CH_YES_	
14	Compander	No	COMP_NO_	E : Not used
		Yes	COMP_YES	
15	PTT ID	OFF	P.ID_OFF_	
		Begin of TX	P.ID_1__	
		End of TX	P.ID_2__	
		Both	P.ID_3__	
16	Begin of TX ID (Only when DTMF/ 2-tone is selected for sig- nalling type)	000~ 9999999999999999	_BOT_ID_	Not valid if Dial ID= disable and PTT ID= off, or EOT is set Display when an item is selected (about 0.5 seconds)
			12345678	Display of the current setting (If it is 8 or more digits, scroll it)
			----- 987	Display when a code is input (Input it with DTMF key)
			Blank	-----
17	Begin of TX ID (Only when 5-tone is selected for signalling type)	OFF	_BOT_OFF	Not valid if PTT ID= off, or EOT is set. Turn the [CH▲/▼] key.
		Encode A-E	_BOT__ A	
17	End of TX ID (Only when DTMF/ 2-tone is selected for sig- nalling type)	000~ 9999999999999999	_EOT_ID_	Not valid if Dial ID= disable and PTT ID= off, or BOT is set Display when an item is selected (about 0.5 seconds)
			12345678	Display of the current setting (If it is 8 or more digits, scroll it)
			----- 987	Display when a code is input (Input it with DTMF key)
			Blank	-----
17	End of TX ID (Only when 5-tone is selected for signalling type)	OFF	_BOT_OFF	Not valid if PTT ID= off, or BOT is set. Turn the [CH▲/▼] key.
		Encode A-H	_EOT__A	

REALIGNMENT

No.	Function	Choices	Display	Remarks
18	Decode 1 ID (Only when 5-tone is selected for signalling type)	OFF	DEC1_OFF	Turn the [CH▲/▼] key.
		Decode A-F	DEC1__A	
19	Decode 2 ID (Only when 5-tone is selected for signalling type)	OFF	DEC2_OFF	Turn the [CH▲/▼] key.
		Decode A-F	DEC2__A	
20	CALL 1 ID (Only when 5-tone is selected for signalling type)	OFF	_CL1_OFF	Turn the [CH▲/▼] key.
		Encode A-H	_CL1__A	
21	CALL 2 ID (Only when 5-tone is selected for signalling type)	OFF	_CL2_OFF	Turn the [CH▲/▼] key.
		Encode A-H	_CL2__A	
22	Transpond ID (Only when 5-tone is selected for signalling type)	OFF	_TSP_OFF	Turn the [CH▲/▼] key.
		Encode A-H	_TSP__A	
23	PTT ID monitor (Only when 5-tone is selected for signalling type)	OPEN	PTTM_YES	Turn the [CH▲/▼] key.
		DISABLE	PTTM_NO_	
24	CALL 1 monitor (Only when 5-tone is selected for signalling type)	OPEN	CL1M_YES	Turn the [CH▲/▼] key.
		DISABLE	CL1M_NO_	
25	CALL 2 monitor (Only when 5-tone is selected for signalling type)	OPEN	CL2M_YES	Turn the [CH▲/▼] key.
		DISABLE	CL2M_NO_	

9-1. Flow Chart

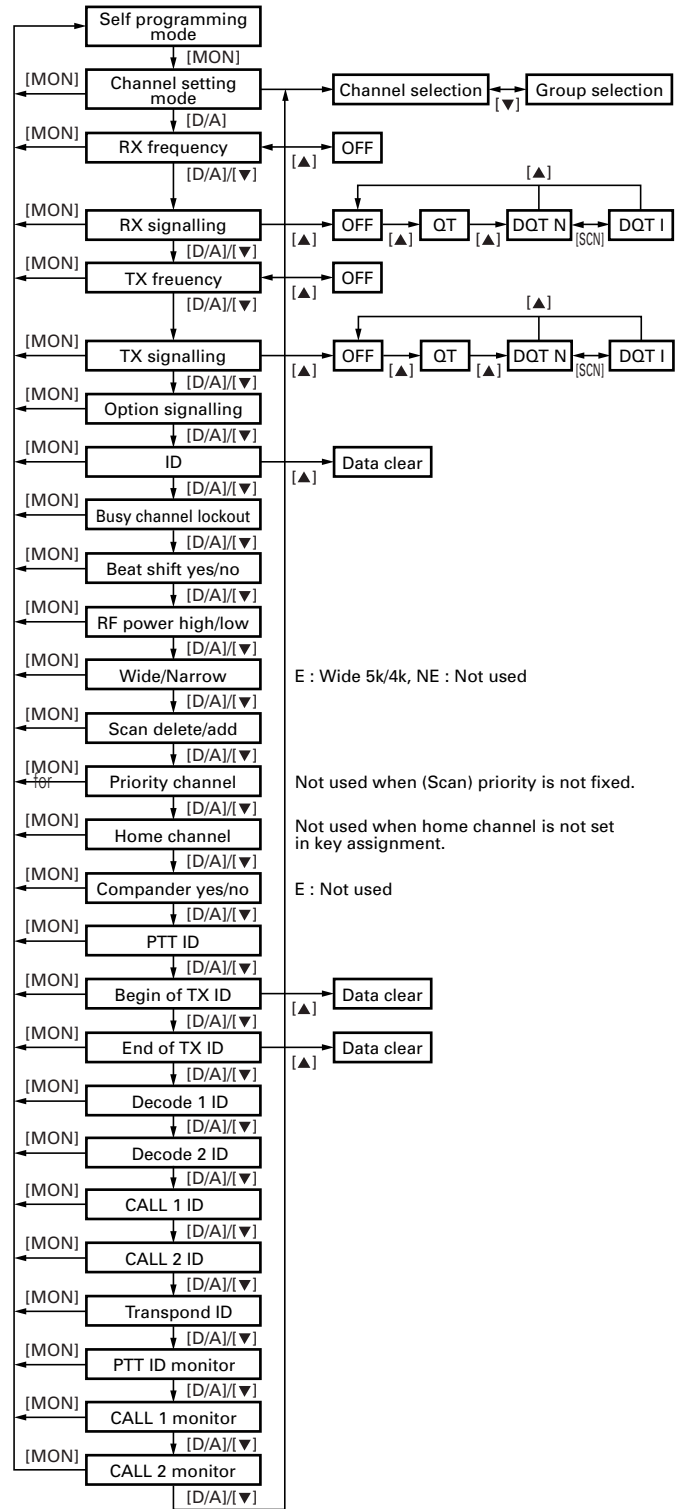

REALIGNMENT

10. Function Setting Mode

All channels can be set up together in the action mode by using the panel keys.

- Pressing [▲] when "SELF" is displayed, sets the function setting mode.
- Select an item set using [▼] then change the selection with the [CH▲/▼].
- The data displayed using [D/A] is stored in the memory and then proceeds to the next item.
- Pressing [▼] proceeds to the next item without storing it in the memory.
- Press [▲] to display "SELF" and return to reset (default) status.

No.	Function	Choices	Display	Remarks
Optional feature				
1	Power on tone	YES/NO	PONT_YES	Default : Yes
2	Control tone	YES/NO	CNTT_YES	Default : Yes
3	Warning tone	YES/NO	WART_YES	Default : Yes
4	Time out timer	OFF, 15~600/ 15s step	TOT__180	Default : 180s
5	TOT pre-alert time	OFF, 1~10/ 1s step	TOTP_OFF	Cannot be set when TOT is off Default : Off
6	TOT rekey time	OFF, 1~60/ 1s step	TOTK_OFF	Cannot be set when TOT is off Default : Off
7	TOT reset time	OFF, 1~15/ 1s step	TOTS_OFF	Cannot be set when TOT is off
8	Squelch level	0~9/1 step	SQL__5__	Default : 5
Others				
9	Panel test/ panel tuning mode	Enable	PTM__ENA	←Default
		Disable	PTM__DIS	Not used for TK-762G

10-1. Flow Chart

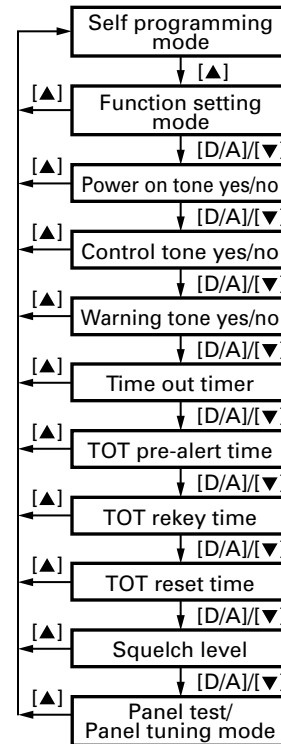

11. Memory Reset Mode (TK-760G only)

You can clear all settings you made in self programming mode, or you can return to the original display.

- Press [SCN] while "SELF" is displayed will change the display to "CANCEL".
- Press [CH▲/▼] to change the display between "CANCEL" and "READY".
- When "READY" is displayed, pressing [SCN] will set all data to default, and "CLEAR" will appear on the display. Press [SCN] again to display "SELF".
- When "CANCEL" is displayed, pressing [SCN] will cancel the reset, and "SELF" will be displayed.

INSTALLATION

1. Accessory Connection Cable (KCT-19 : Option)

The KCT-19 is an accessory connection cable for connecting external equipment. The connector has 15 pins and the necessary signal lines are selected for use.

1-1. Installing the KCT-19 in the transceiver

1. Remove the upper half of the transceiver case, and lift the DC cord bushing (❶) from the chassis.
2. Remove the pad as shown in Figure 1 (❷).
3. Insert the KCT-19 cable (❸) into the chassis (❹).
The wire harness band (❺) must be inside the chassis.
4. Replace the DC cord bushing (❻).
5. Connect the KCT-19 to the TX-RX unit (A/2) as shown in Figure 2 (❼).
6. Connect the KCT-19 to the external accessory by inserting the crimp terminal (❽) into the square plug (❾), both of which are supplied with the KCT-19.

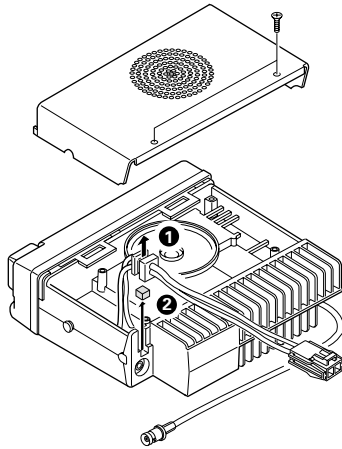

Fig. 1

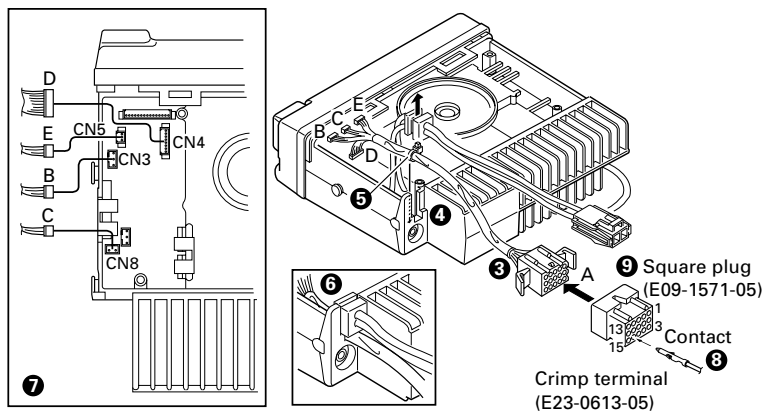

Fig. 2

1-2. KCT-19 Accessory Port Function

No. (A)	No. (B,C,D,E)	Name	Function	Note
1	D-2	DTC	Data channel control/ External hook input	*1
2	D-5	ME	External microphone ground	
3	D-3	IGN	Ignition sense input	
4	D-1	DEO	Receiver detector output	
5	D-6	MI	External microphone input	
6	B-2	E	Ground	
7	B-3	SB	Switched B+, DC 13.2V output. Maximum 1A	
8	D-7	PTT	External PTT input	*1
9	D-4	DI	Data modulation input	
10	B-1	HOR	Horn alert/call output	
11	D-8	SQ	Squelch detect output Busy : H	*1
12	C-1	SP	Speaker audio output.	
13	E-1	AM	Speaker mute input, active high	
14	E-2	MM	MIC mute input, active high	
15	E-3	EMG	Foot switch input, active low	*2

*1 : MDT mode

*2 : Emergency mode

INSTALLATION

2. Accessory Terminal (TX-RX Unit)

2-1. External Connector Accessory Terminal Method

No.	Name	I/O	Description	Note	
CN1	1	8C	DC 8V output		
	2	5S	DC 5V output		
	3	AUX5	O		
	4	AUX6	O		
	5	NC	-	Non-connection	
	6	AUX3	O	SQ : Squelch detect output	*1
	7	AUX1	I	PTT : External PTT input	*1
	8	AUX4	O		
	9	AUX2	I	DTC : Data channel control/ External hook input	
			I	CHDATA : Channel control serial data input	
	10	ALT	I	Alert tone input	
	11	AFO	O	Receiver audio signal output	
	12	AFI	I	Receiver audio signal input	
	13	MII	I	Transmit audio signal input	
	14	MIO	O	Transmit audio signal output	
15	GND	-	Ground		
CN3	1	HOR	Horn alert/call output		
	2	E	-	Ground	
	3	SB	O	Switched B+, DC 13.2V output, Maximum 1A	
CN4	1	DEO	Receiver detector output Level : 0.5Vrms (Standard modulation)		
	2	DTC	I	Data channel control/ External hook input	
	3	IGN	I	Ignition sense input	
	4	DI	I	Data modulation input	
	5	ME	-	External microphone ground	
	6	MI	I	External microphone input	
	7	PTT	I	External PTT input, active low	
	8	SQ	O	Squelch detect output	
CN5	1	AM	I	Speaker mute input, active high	
	2	MM	I	MIC mute input, active high	
	3	EMG	I	EMG : Foot switch input, active low	*2
CN7	1	PA/LI	O	Relay for PA function KAP-1 control	
			O	PA/LI ON : High, PA/LI OFF : Low	
	2	SPO	O	Audio signal output to KAP-1	
	3	SPI	I	Audio signal input from KAP-1	
CN8	1	SP	O	Audio signal output to internal/external speaker	
	2	E	-	Ground	

*1 : MDT mode

*2 : Emergency mode

3. Ignition Sense Cable (KCT-18 : Option)

The KCT-18 is an optional cable for enabling the ignition function. The ignition function lets you turn the power to the transceiver on and off with the car ignition key.

If you use the Horn Alert function or the Manual Relay function, you can turn the function off while driving with the ignition key.

3-1. Connecting the KCT-18 to the Transceiver

1. Install the KCT-19 in the transceiver. (See the KCT-19 section.)
2. Insert the KCT-18 lead terminal (2) into pin 3 of the square plug (1) supplied with the KCT-19, then insert the square plug into the KCT-19 connector (3).

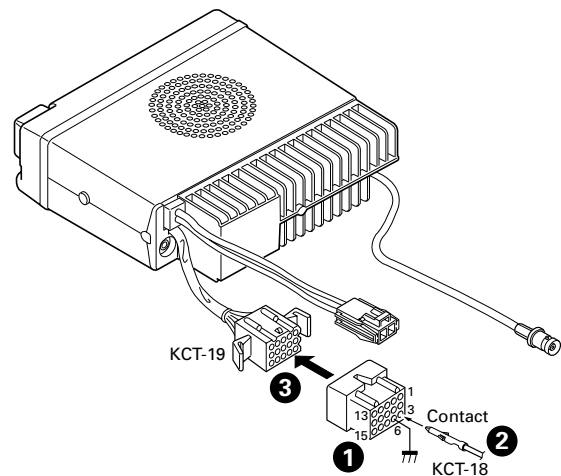

Fig. 3

3-2. Modifying the Transceiver

Modify the transceiver as follows to turn the power or the Horn Alert or Manual Relay function on and off with the ignition key.

1. Remove the lower half of the transceiver case.
2. Set jumper resistors (0Ω) R134 and R135 of the TX-RX unit (A/2) as shown in Table 1.

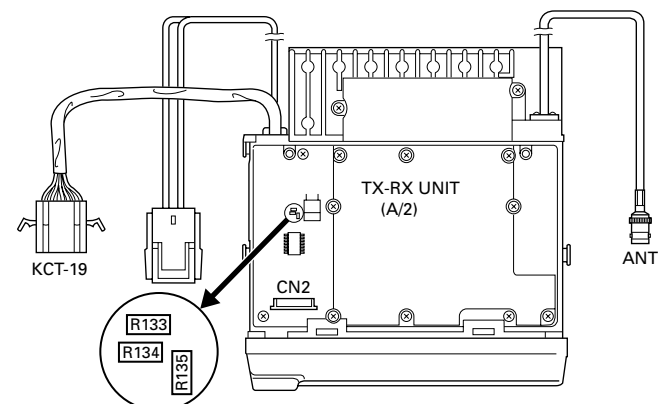

Fig. 4

INSTALLATION

Operation when KCT-18 is connected	R134	R135	
	Enable	Enable	← KCT-18 cannot be connected
Power on/off and Horn Alert or AUX-A on/off	Disable	Enable	
Horn Alert or AUX-A on/off	Enable	Disable	
	Disable	Disable	← Power cannot be turned on

Table 1 R134 and R135 setup chart

4. PA/HA Unit (KAP-1 : Option)

4-1. Installing the KAP-1 in the Transceiver

The Horn Alert (max. 2A drive) and Public Address functions are enabled by inserting the KAP-1 W1 (3P; white/black/red) into CN3 on the TX-RX unit, inserting W2 (3P; green) into CN7 on the TX-RX unit, and connecting the KCT-19 (option) to CN2 and CN3 of the KAP-1.

• Installation procedure

1. Open the upper case of the transceiver.
2. Insert the two cables (❶) with connectors from the KAP-1 switch unit into the connectors on the transceiver.
3. Secure the switch unit board to the chassis with a screw (❸). The notch (❷) in the board must be placed at the front left side.
4. Attach the cushion on the top of the KAP-1 switch unit.

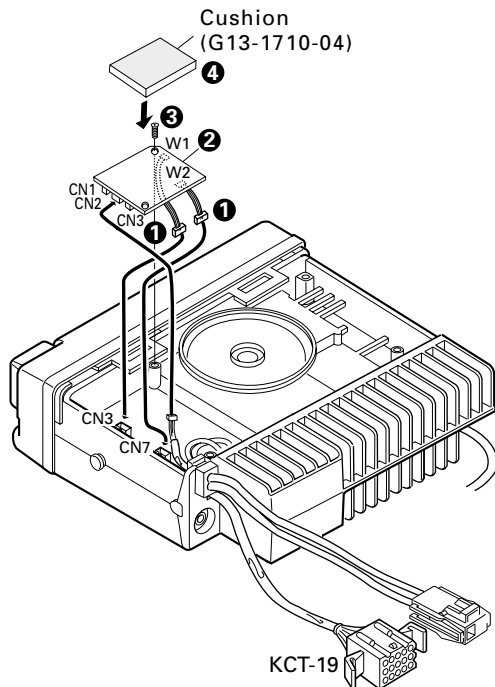

Fig. 5

4-2. Modifying the Transceiver

• Horn alert

The signal from pin 4 of IC9 on the TX-RX unit turns Q5 and Q1 on and off and drives KAP-1 HA relay K2 to drive the horn with a maximum of 2A.

The default output is HR1. The relay open output can be obtained between HR1 and HR2 by removing R1 in the KAP-1.

	R1	Output form
HR1 (Default)	Enable	
HR2	Disable	

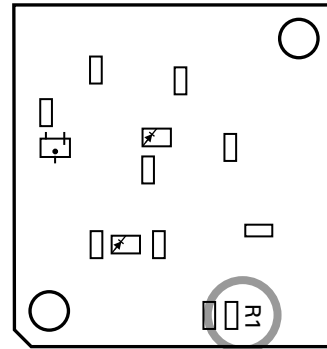

Fig. 6 KAP-1 foil side view

• Public address

The signal from pin 13 of IC9 on the TX-RX unit drives PA relay K1 in the KAP-1 and switches the audio power amplifier output between the external PA system (through KCT-19) and internal and external speakers.

To use the PA function, R153 on the TX-RX unit must be removed.

	R153
Use the PA function	Disable
Do not use the PA function	Enable

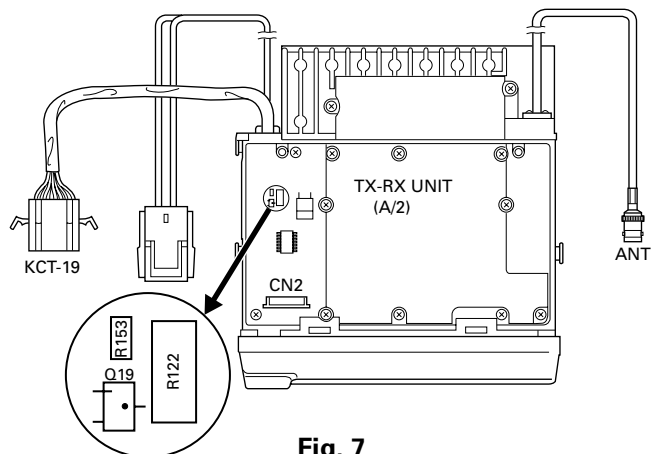

Fig. 7

INSTALLATION

4-3. Others

If the PA and HR2 are not necessary and the speaker output is output to an external unit through the KCT-19, connect the KCT-19 C connector to CN8 on the TX-RX unit.

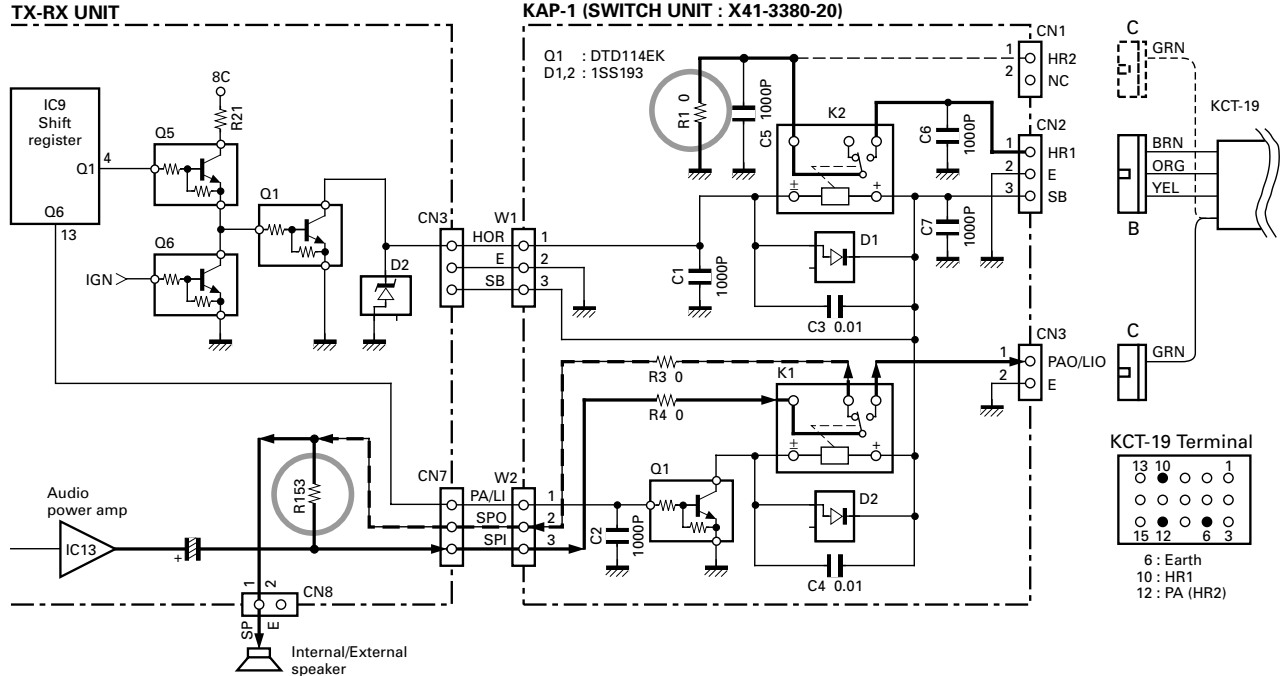

Fig. 8

5. Emergency Mode

5-1. Transceiver Modification Procedure

• Install the foot switch

Install the foot switch through the KCT-19 and KCT-18. When the switch is treaded on, the radio enters the emergency mode.

• Change the power switch circuit

TX-RX unit (B/2) : Control section
 \$R705 : Attach (R92-1252-05, 0Ω)

TX-RX unit (A/2) : RF section
 R142 : Remove (RK73GB1J473J, 47kΩ)

Once the transceiver is modified, it cannot be turned on and off with the power switch. The power switch turns the LCD backlight and display on and off. (The power is switched on and off by IGNITION SENSE.)

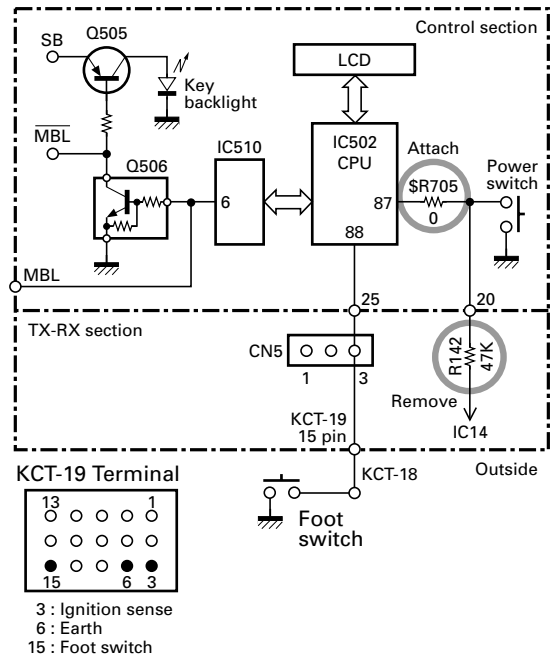

Fig. 9

INSTALLATION

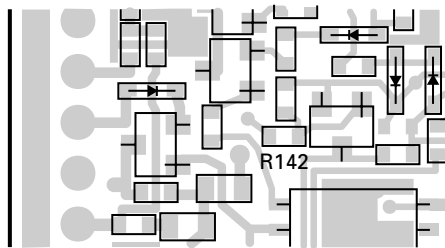
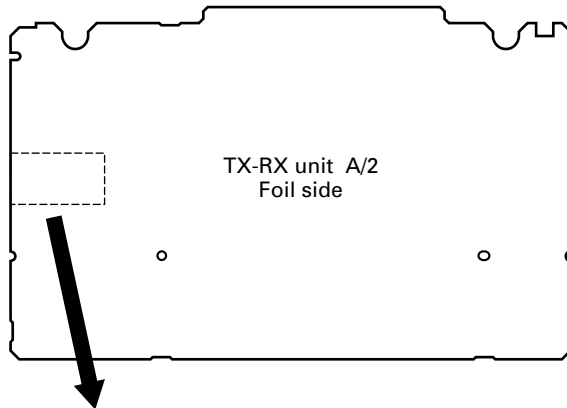
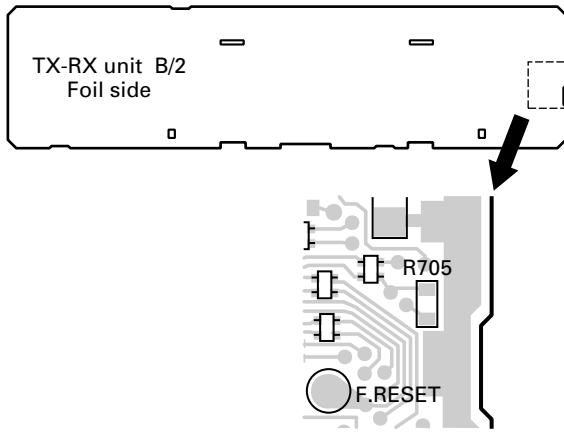

Fig. 10

6. Fitting the Control Panel Upside Down

The TK-760G/762G control panel can be fitted upside down, so the transceiver can be mounted with its internal speaker (in the upper half of the case) facing down in your car.

1. Remove the control panel and the TX-RX unit (B/2) control section. (Fig. 11)

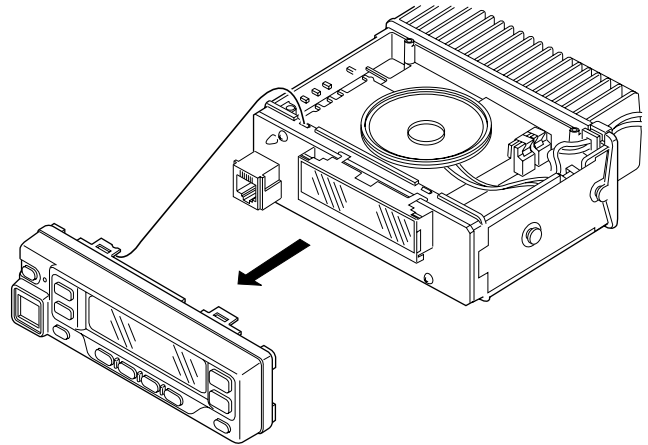

Fig. 11

2. Fold the flat cable (1) in the opposite direction (2).
3. Rotate the control section (3) 180 degrees (4).
4. Insert the flat cable into the control section connector, CN501 (5).
5. Mount the control section on the transceiver (6).

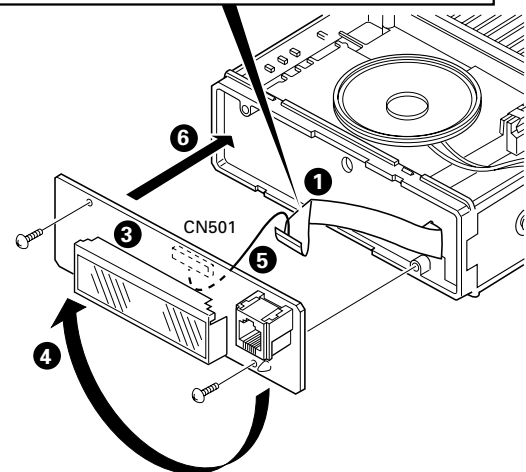
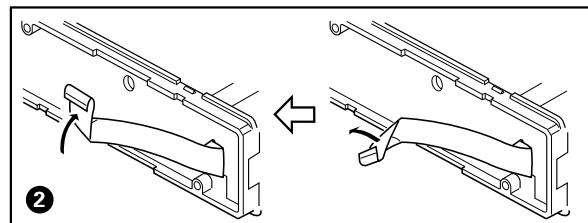

Fig. 12

INSTALLATION

- Rotate the control panel 180 degrees and mount it on the transceiver. Refit the two halves of the case to complete installation. (Fig. 13)

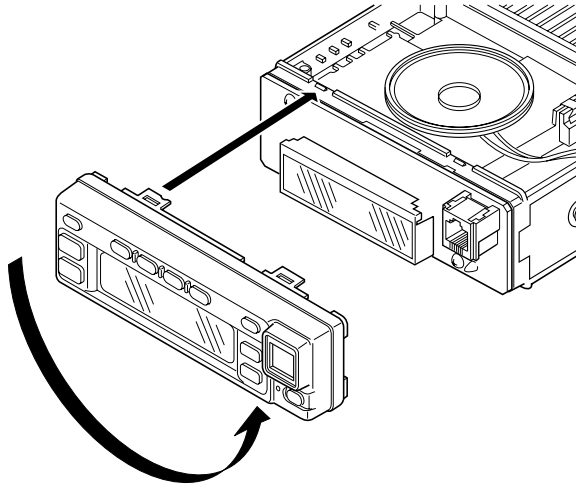

Fig. 13

7. External Speaker

7-1. KES-3 : Option

The KES-3 is an external speaker for the 3.5-mm-diameter speaker jack.

• Connection procedure

- Connect the KES-3 to the 3.5-mm-diameter speaker jack on the rear of the transceiver.

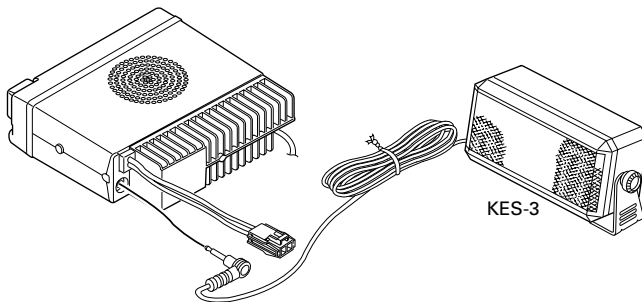

Fig. 14

7-2. KES-4 : Option

The KES-4 is an external speaker used with the accessory connection cable.

• Connection procedure

- Install the KCT-19 in the transceiver. (See the KCT-19 section.)
- Insert the crimp terminal into the square plug supplied with the KCT-19.
- Connect CN8 of the transceiver to connector C of the KCT-19 instead of to the internal speaker connector.

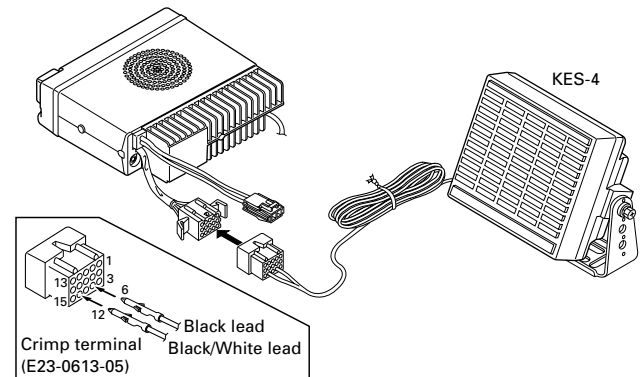

Fig. 15

CIRCUIT DESCRIPTION

Frequency Configuration

The receiver utilizes double conversion. The first IF is 49.95MHz and the second IF is 450kHz. The first local oscillator signal is supplied from the PLL circuit.

The PLL circuit in the transmitter generates the necessary frequencies. Figure 1 shows the frequencies.

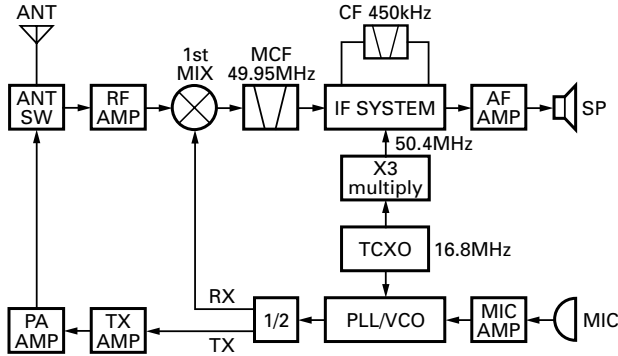

Fig. 1 Frequency configuration

Receiver System

The receiver is double conversion superheterodyne. The frequency configuration is shown in Figure 1.

■ Front-end RF Amplifier

An incoming signal from the antenna is applied to an RF amplifier (Q27) after passing through a transmit/receive switch circuit (D33 and D34 are off) and a band pass filter (L18). After the signal is amplified (Q27), the signal is filtered through a band pass filter (L11, L13 and L15) to eliminate unwanted signals before it is passed to the first mixer. Band pass filters (L18, L11, L13 and L15) have varactor diodes (D30, D31, D18, D23 and D28).

The voltage of these diodes are controlled by to track the CPU (IC502) center frequency of the band pass filter. (See Fig. 2)

■ First Mixer

The signal from the RF amplifier is heterodyned with the first local oscillator signal from the PLL frequency synthesizer circuit at the first mixer (Q15) to create a 49.95MHz first intermediate frequency (1st IF) signal. The first IF signal is then fed through one pair of monolithic crystal filters (MCF : XF1) to further remove spurious signals.

■ IF Amplifier

The first IF signal is amplified by Q13, and the enters IC5 (FM processing IC). The signal is heterodyned again with a second local oscillator signal within IC5 to create a 450kHz second IF signal. The second IF signal is then fed through a 450kHz ceramic filter (CF2) to further eliminate unwanted signals before it is amplified and FM detected in IC5.

Item	Rating
Nominal center frequency	49.95MHz
Pass bandwidth	±5.0kHz or more at 3dB
35dB stop bandwidth	±20.0kHz or less
Ripple	1.0dB or less
Insertion loss	5.0dB or less
Guaranteed attenuation	80dB or more at fo±1MHz
	Spurious : 40dB or more within fo±1MHz
Terminal impedance	350Ω±5% / 5.5pF±0.5pF

Table 1 Crystal filter (L71-0551-25) : XF1

Item	Rating
Nominal center frequency	450kHz
6dB bandwidth	±4.5kHz or more
50dB bandwidth	±10.0kHz or less
Ripple	2.0dB or less
Insertion loss	6.0dB or less
Guaranteed attenuation	55.0dB or more within fo±100kHz
Terminal impedance	2.0kΩ

Table 2 Ceramic filter (L71-0959-05) : CF2 (NE)

Item	Rating
Nominal center frequency	450kHz
6dB bandwidth	±6.0kHz or more
50dB bandwidth	±12.5kHz or less
Ripple	3.0dB or less
Insertion loss	6.0dB or less
Guaranteed attenuation	35.0dB or more within fo±100kHz
Terminal impedance	2.0kΩ

Table 3 Ceramic filter (L72-0973-05) : CF2 (E)

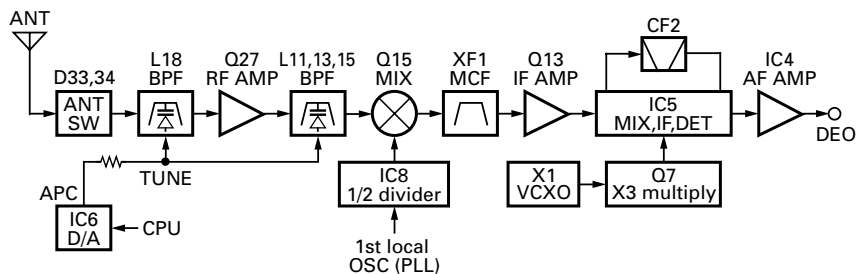

Fig. 2 Receiver system

CIRCUIT DESCRIPTION

■ AF Signal System

The detection signal (DEO) from the TX-RX unit goes to the audio processor (IC508) of the control unit. The signal passes through a filter in the audio processor to adjust the gain, and is output to IC507. IC507 sums the AF signal and the DTMF signal, BEEP signal and returns the resulting signal to the TX-RX unit. The signal (AFO) sent to the TX-RX unit is input to the D/A converter (IC6). The AFO output level is adjusted by the D/A converter. The signal output from the D/A converter is input to the audio power amplifier (IC13). The AF signal from IC13 switches between the internal speaker and speaker jack (J1) output.

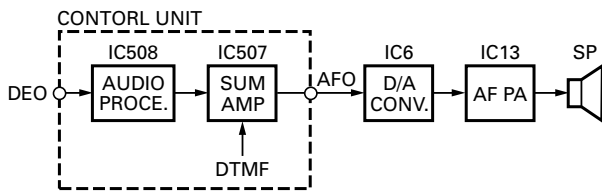

Fig. 3 AF signal system

■ Squelch Circuit

The detection output from the FM IF IC (IC5) passes through a band-pass filter and a noise amplifier (Q10) in the control unit to detect noise. A voltage is applied to the CPU (IC502). The CPU controls squelch according to the voltage (ASQ) level. The signal from the RSSI pin of IC5 is monitored. The electric field strength of the receive signal can be known before the ASQ voltage is input to the CPU, and the scan stop speed is improved.

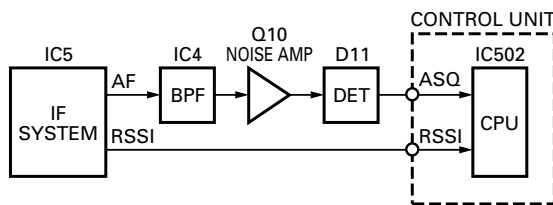

Fig. 4 Squelch circuit

■ PLL Frequency Synthesizer

The PLL circuit generates the first local oscillator signal for reception and the RF signal for transmission.

■ PLL

The frequency step of the PLL circuit is 5 or 6.25kHz. A 16.8MHz reference oscillator signal is divided at IC3 by a fixed counter to produce the 5 or 6.25kHz reference frequency. The voltage controlled oscillator (VCO) output signal is buffer amplified by Q106 (Sub-unit), then divided in IC3 by a dual-module programmable counter. The divided signal is compared in phase with the 5 or 6.25kHz reference signal in the phase comparator in IC3. The output signal from the phase comparator is filtered through a low-pass filter and passed to the VCO to control the oscillator frequency. (See Fig. 5)

■ VCO

The TK-760G/762G has VCO in a Sub-unit (A1) housed in a solid shielded case and connected to the TX-RX unit through CN101.

The operating frequency is generated by Q103 in transmit mode and Q101 in receive mode. The oscillator frequency is controlled by applying the VCO control voltage, obtained from the phase comparator, to the varactor diodes (D102 and D104 in transmit mode and D101 and D103 in receive mode). The RX (ST) pin is set low in receive mode causing Q102 to turn Q103 off, and turn Q101 on. The RX (ST) pin is set low in transmit mode. The outputs from Q101 and Q103 are amplified by Q106 and sent to the buffer amplifiers.

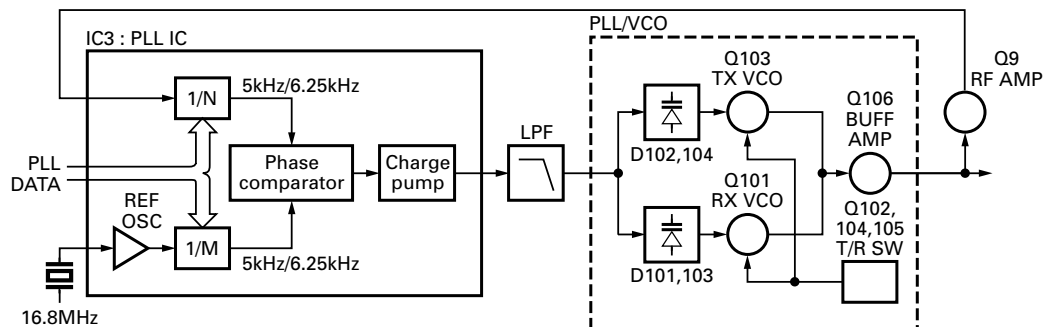

Fig. 5 PLL circuit

CIRCUIT DESCRIPTION

■ Unlock Circuit

During reception, the 8RC signal goes high, the 8TC signal goes low, and Q16 turns on. Q18 turns on and a voltage is applied to the collector (8R). During transmission, the 8RC signal goes low, the 8TC signal goes high and Q29 turns on. Q28 turns on and a voltage is applied to 8T.

The CPU in the control unit monitors the PLL (IC3) LD signal directly. When the PLL is unlocked during transmission, the PLL LD signal goes low. The CPU detects this signal and makes the 8TC signal low. When the 8TC signal goes low, no voltage is applied to 8T, and no signal is transmitted.

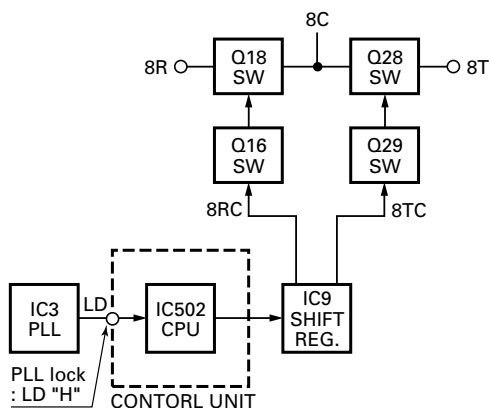

Fig. 6 Unlock circuit

Transmitter System

■ Outline

The transmitter circuit produces and amplifies the desired frequency directly. It FM-modulates the carrier signal by means of a varicap diode

■ Power Amplifier Circuit

The transmit output signal from the VCO is amplified to a specified level of the power module (IC400) by the drive block (Q22 and Q25). The amplified signal passes through the transmission/reception selection diode (D16) and goes to a low-pass filter. The low-pass filter removes unwanted high-frequency harmonic components, and the resulting signal is goes the antenna terminal.

■ APC Circuit

The automatic transmission power control (APC) circuit detects part of a power module output with a diode (D35, D36) and applies a voltage to IC15. IC15 compares the APC control voltage (PC) generated by the D/A converter (IC6) and DC amplifier (IC7) with the detection output voltage to control Q31 and Q32, generates DB voltage from B voltage, and stabilizes transmission output.

The APC circuit is configured to protect over current of the power module due to fluctuations of the load at the antenna end and to stabilize transmission output at voltage and temperature variations.

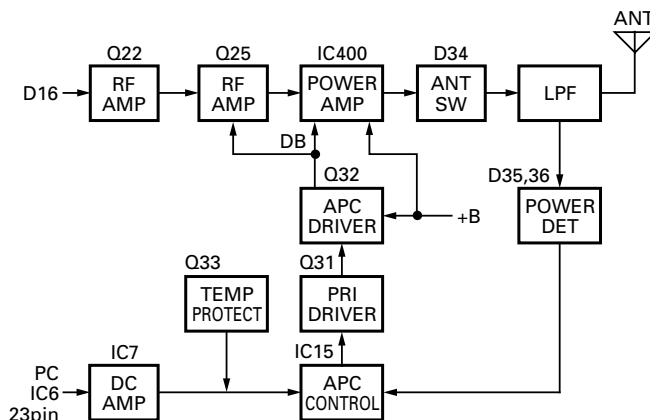

Fig. 8 APC circuit

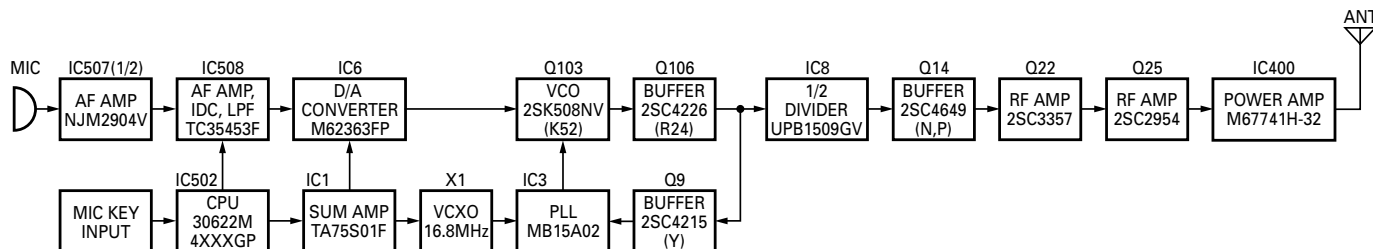

Fig. 7 Transmitter system

CIRCUIT DESCRIPTION

Control Circuit

The CPU carries out the following tasks:

- 1) Controls the shift register (IC9, IC510) AF MUTE, WIDE/NARROW, T/R KEY outputs.
- 2) Adjusts the AF signal level of the audio processor (IC508) and turns the filter select compounder on or off.
- 3) Controls the DTMF decoder (IC511).
- 4) Controls the LCD assembly display data.
- 5) Controls the PLL (IC3).
- 6) Controls the D/A converter (IC6) and adjusts the volume, modulation and transmission power.

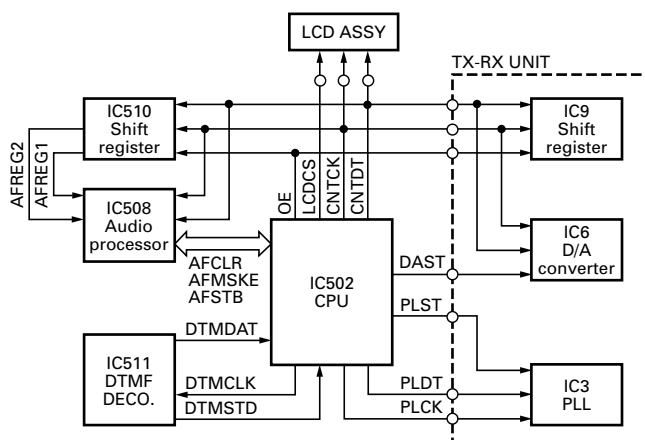

Fig. 9 Control circuit

Memory Circuit

The transceiver has a 2M-bit (256k x 8) flash ROM (IC501) and an 8k-bit EEPROM (IC505). The flash ROM contains firmware programs, data and user data which is programmed with the FPU. The EEPROM contains adjustment data. The CPU (IC502) controls the flash ROM through an external address bus and an external data bus. The CPU controls the EEPROM through two serial data lines.

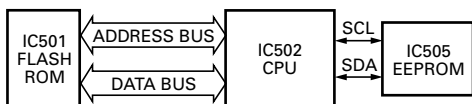

Fig. 10 Memory circuit

Display Circuit

The CPU (IC502) controls the shift register (IC510) and display LEDs. When the LED1 line goes high when the transceiver is busy, Q508 turns on and the green LED on D521 lights. In transmit mode, the LED0 line goes high, Q504 turns on and the red light lights. Backlighting LEDs for the key operation unit (D509~D514) and LCD are provided.

When the MBL line goes high, Q506 turns on, then Q505 turns on, and the key illumination LED lights. A voltage is applied to the MBL line to turn on the LCD backlight.

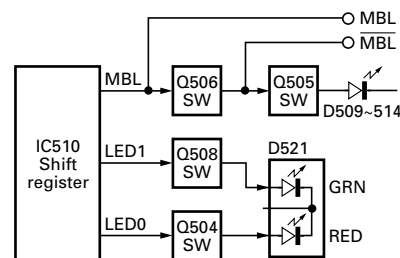

Fig. 11 Display circuit

Key Matrix Circuit

The TK-760G/762G front panel has function keys. Each of them is connected to a cross point of a matrix of the KIN0 to KOUT2 ports of the microprocessor. The KOUT0 to KOUT2 ports are always high, while the KIN0 to KIN2 ports are always low.

The microprocessor monitors the status of the KIN0 to KOUT2 ports. If the state of one of the ports changes, the microprocessor assumes that the key at the matrix point corresponding to that port has been pressed.

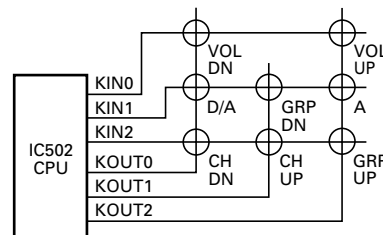

Fig. 12 Key matrix circuit

Encode

The QT and DQT signals are output from TO of the CPU (IC502) and summed with the external pin DI line by the summing amplifier (IC2) and the resulting signal goes to the D/A converter (IC6) of the TX-RX unit. The DTMF and 2-TONE signals are output from DTMF of the CPU and goes to the audio processor (IC508). The signal is summed with a MIC signal by the audio processor (IC508), and the resulting signal passes through an analog switch (IC509) and goes to the TX-RX unit (MO).

The D/A converter (IC6) adjusts the MO level and the balance between the MO and TO levels. Part of a TO signal is summed with MO and the resulting signal goes to the MD pin of the VCO. This signal is applied to a varicap diode in the VCO for direct FM modulation.

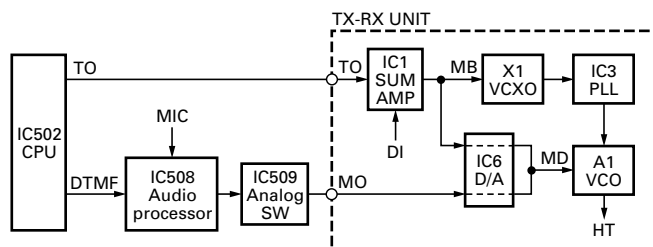

Fig. 13 Encode

CIRCUIT DESCRIPTION

■ Decode

• QT/DQT/DTMF

The signal (DEO) detected by the TX-RX unit passes through two low-pass filters of IC513, goes to TOI of the CPU (IC502) to decode QT, DQT. The DTMF signal is decoded by a dedicated IC (IC511) and the resulting signal is sent to the CPU (IC502) as serial data.

• 2-tone, 5-tone

The detected signal passes through audio processor (IC508) RX OUT. Then it is filtered through IC514 2-stage low-pass filtered to enter CPU (IC502) to decode 2-tone and 5-tone signalling.

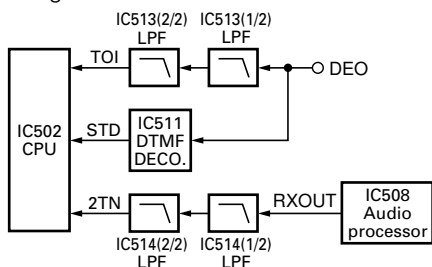

Fig. 14 Decode

■ D/A Converter

The D/A converter (IC6) is used to adjust TONE and MO modulation, AF volume, TV voltage, FC reference voltage, and PC POWER CONTROL voltage level.

Adjustment values are sent from the CPU as serial data. The D/A converter has a resolution of 256 and the following relationship is valid:

$$D/A \text{ output} = (V_{in} - V_{DAref}) / 256 \times n + V_{DAref}$$

V_{in} : Analog input

V_{DAref} : D/A reference voltage

n : Serial data value from the microprocessor (CPU)

■ Horn Control

The horn switch, consisting of Q1, Q5, and Q6, controls the horn relay. It is supplied by the dealer to provide the external horn alert function.

Q6 disables horn alert, turning on when its base is high, to inhibit the function. Normally, the output from IC9 is low, and Q5 is off; the base of Q1 is about 0V and Q1 is off. When horn alert is enabled, the output from IC9 goes high and Q5 turns on. The base current flows through R21 to Q1 to turn Q1 on. Q1 can sink a maximum of 100mA. If the optional KAP-1 is used, it can drive up to 2A.

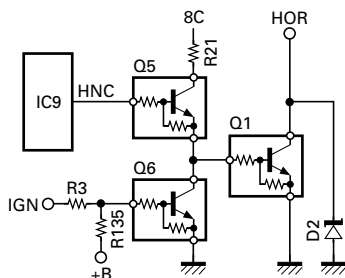

Fig. 15 Horn control circuit

■ PA Switch

If the optional KAP-1 is used (see the separate section for details), the PA (Public Address) function becomes available. In this case, the signal flow changes as follows;

• PA off

For TX, the switch which is between pins 10 and 11 of IC509 closes. The audio signal from the microphone passes through IC509 and IC6 and modulates the VCO.

For RX, the switch which is between pins 3 and 4 of IC509 closes. The detected signal passes through IC509, IC508, IC507, IC6 and IC13 and is then output to the speaker.

• PA on

Since the switch which is between pins 10 and 11 of IC509 is open, the switch which is between pins 3 and 4 of IC509 is open, and the switch which is between pins 1 and 2 of IC509 is closed, the audio signal from the microphone passes through IC508, IC507 and IC6, and then goes to IC13. The signal is output to the external PA system through the PA relay in KAP-1.

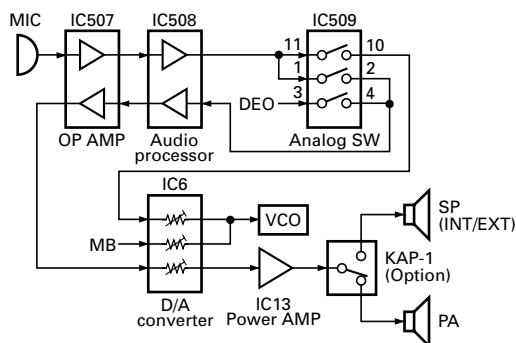

Fig. 16 PA switch

Power Supply Circuit

When the POWER switch on the control unit is pressed, the PSW signal goes low. This signal is inverted by Q26 and sent to a flip-flop IC (IC14). This IC outputs a control signal when the PSW goes low. When the power turns on, pin 1 of IC14 outputs a low signal and Q20 turns on. The base of Q19 goes high, Q19 turns on, SB SW (Q23) turns on and power (SB) is supplied to the set.

This circuit has an overvoltage protection circuit. If a DC voltage of 20 V or higher is applied to the power cable, D21 turns on and a voltage is applied to the base of Q21. This voltage turns Q21 on and turns Q19 and SBSW off.

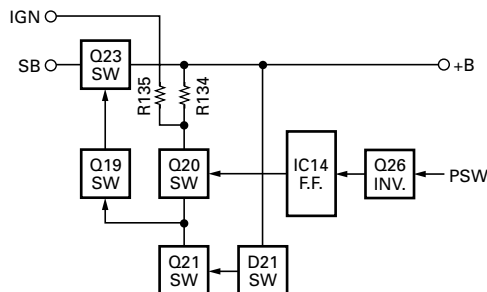

Fig. 17 Power supply circuit

SEMICONDUCTOR DATA

Microprocessor : 30622M4102GP (TX-RX Unit IC502)

■ Terminal function

Pin No.	Name	I/O	Function	Pin No.	Name	I/O	Function
1	EMGT	O	External MIC control. Mobile MIC : H	39	HOLD	I	Not used.
2	DTMF	O	DTMF/2TONE/BEEP/5TONE output.	40,41	NC	-	NC.
3	2TN	I	2TONE and 5TONE decode pulse input.	42	RD	O	READ signal.
4	DTMSTD	I	DTMF decode detect. Detect : H	43	NC	-	NC.
5	SIM	I	Destination select.	44	WR	O	WRITE signal.
6	BYTE	I	+5V (5C).	45	LCDCS	O	LCD chip enable output.
7	CNVSS	I	GND.	46	CNTDAT	O	Common data output. (LCD, SHIFT REG, VOL, Audio processor)
8	AFSTB	O	Base band IC strobe/reset output.	47	CNTCLK	O	Common clock output. (EEPROM, LCD, SHIFT REG, VOL, Audio processor)
9	AFFCLK	O	Base band IC frame detect reset/ system reset output.	48	CSO	-	Chip select signal.
10	RESET	I	Reset.	49	A19	-	Not used.
11	XOUT	O	Clock output.	50~59	A18~A9	-	Flash memory address bus.
12	VSS	-	GND.	60	ACC	-	+5V.
13	XIN	I	Clock input.	61	A8	-	Flash memory address bus.
14	VCC	-	+5V.	62	VSS	-	GND.
15	NC	I	Pull up.	63~70	A7~A0	-	Flash memory address bus.
16	MICDAT	I/O	MIC data input/output.	71~73	KIN0~KIN2	I	Key scan input.
17	AUX3	I/O	Option board port 3.	74	MON	I	[MON] key input. On : L
18	NC	-	NC.	75	SCN	I	[SCN] key input. On : L
19	OE	I	Output enable control sift register.	76	PLLUL	I	PLL unlock detect input. Unlock : L
20	NC	-	NC.	77	PLLSTB	O	PLL strobe output. Latch : H
21	EEPDAT	I/O	EEPROM data input/output.	78	MUTE	I	RX audio mute. Mute : H
22	TO	O	QT/DQT modulation output.	79~86	D7~D0	-	Flash memory data bus.
23	AUX1	I	Option board port 1.	87	PWR (EMG)	I	[PWR] key input (key interrupt). On : L
24	SFTSTB1	O	Shift register strobe output.	88	EMG	I	Emergency input (key interrupt). On : L
25	DACSTB	O	D/A converter enable output.	89	RFDAT	O	PLL data output.
26	PTT	I	PTT. PTT on : L	90	RFCLK	O	PLL clock output.
27	NC	-	NC.	91	NC	-	NC.
28	NC	-	NC.	92	RSSQL	I	Receive signal strength indicator input.
29	AUX4	O	Option board port 4.	93	ANLSQL	I	Analog squelch level input.
30	AUX2	I/O	Option board port 2.	94	AVSS	-	GND.
31	PA	O	MIC audio line sw control. PA : H	95	TOI	I	QT/DQT signal input.
32	KOUT2	O	Key scan output 2.	96	VREF	-	Reference voltage input.
33	TXD	O	Serial data. PTT on : L	97	AVCC	-	+5V.
34	HOOK	I	HOOK/RXD. On hook : L	98	DTMPD	O	DTMF IC power control. Power down : H
35	KOUT1	O	Key scan output 1.	99	DTMCLK	O	DTMF IC decode clock output.
36	KOUT0	O	Key scan output 0.	100	DTMDAT	I	DTMF IC decode data input.
37	RDY	I	Pull up.				
38	NC	-	NC.				

DESCRIPTION OF COMPONENTS

Display Unit (X54-3270-10) : TK-760G

Ref. No.	Use/Function	Operation/Condition
D801	Reverse current prevention	
D802~805	Light emission	
D808	Current stability	
IC801	LCD driver	
Q801	DC switch (LED)	

Display Unit (X54-3280-10) : TK-762G

Ref. No.	Use/Function	Operation/Condition
D801	Light emission	
D802	Reverse current prevention	
D803,804	Light emission	
IC801	LCD driver	
Q801~809	DC switch (LED)	

TX-RX Unit (X57-595X-XX)

2-71 : TK-760G(N) 2-72 : TK-762G(N)

2-73 : TK-762G 2-74 : TK-760G

Ref. No.	Use/Function	Operation/Condition
D1	Surge absorption	
D2	Voltage reference	
D3~5	Surge absorption	
D9	DC switch	
D11	Noise amp detect	
D14	Surge absorption	
D15	OR gate	SP mute, AM
D16	RF switch (TX/RX)	Heterodyne
D17	Temperature compensation	Drive
D18	RF BPF tuning	
D19	Surge absorption	
D20	Reverse current prevention	
D21	Voltage reference	
D22	Temperature compensation	Drive
D23	RF BPF tuning	
D24	Voltage reference	
D25	Surge absorption	
D27	Reverse current prevention	

Ref. No.	Use/Function	Operation/Condition
D28	RF BPF tuning	
D29	Reverse current prevention	
D30,31	RF BPF tuning	
D33,34	ANT switch	
D35,36	APC voltage detect	
D39	Voltage reference	Power protection
D40	Charge	DEO
D41	Voltage drop	Charge pump
D501	Reverse current prevention	KOUT 0
D502	Reverse current prevention	KOUT 1
D503	Reverse current prevention	KOUT 2
D504	Reverse current prevention	KOUT 0
D505	Reverse current prevention	KOUT 1
D506	Voltage discharger	When powering down
D507	Reverse current prevention	KOUT 2
D508	Limiter	MIC
D509~514	Key backlight	Active while MBL is H
D521	Busy/TX LED	Lights green while busy, red while TX
D523	OR gate	MIC mute, MM, MM2
D524	Surge absorption	HOOK/RXD
D525	Surge absorption	PTT/TXD
D526	Current protection	
D527	Surge absorption	CM
D528	Surge absorption	MBL
D529	Limiter	QT/DQT decode limiter
IC1	Sum amplifier	DI, TO mixer
IC2	DC amplifier	FC, TCXO control
IC3	PLL synthesizer	Reference 16.8MHz, PLL lock : LD H
IC4	Amplifier	DEO
IC5	FM demodulation	Quadrature detector, 2nd mixer, OSC, IF amplifier, RSSI
IC6	D/A converter	
IC7	DC amplifier	PC/TV control
IC8	Prescaler	1/2 prescaler
IC9	Shift/Store register	HNC, 8RC, 8TC, SPMUTE, RX, PA/LI, AUX5, AUX6

DESCRIPTION OF COMPONENTS

Ref. No.	Use/Function	Operation/Condition
IC10	5V AVR	5C (TX/RX)
IC11	9V AVR	9C
IC12	8V AVR	8C
IC13	AF amplifier	
IC14	Power supply logic circuit control	
IC15	DC amplifier	APC control
IC400	Power module	
IC501	Flash ROM	
IC502	CPU	
IC503	Reset IC	Low voltage output when powering up
IC505	EEPROM	
IC507	Amplifier	MIC, AFO
IC508	Audio processor	Compander, MIC amplifier, ALC, AF filter, IDC
IC509	Analog switch	MO, DEO, EMG, MI switch
IC510	Shift/Store register	W/N, MM2, MBL, LED0, LED1, AFREG1, AFREG2, BSHIFT
IC511	DTMF decode	
IC512	5V AVR	5C (control)
IC513	Amplifier	QT/DQT decode
IC514	Amplifier	2-Tone and 5-tone decode
Q1	DC switch	HOR
Q2	DC switch	5S
Q5	DC switch	HNC
Q6	DC switch	IGN
Q7	Buffer amplifier	16.8MHz x 3
Q8	Lipple filter	8CL
Q9	Buffer amplifier	PLL fin
Q10	Noise amplifier	Squelch
Q11	Charge pump	øP
Q12	Charge pump	øR
Q13	IF amplifier	49.95MHz
Q14	Buffer amplifier	Hetetodyne
Q15	Mixer	
Q16	DC switch	8R cont, active while RX
Q17	AF mute	Active while AF mute
Q18	DC switch	8R, active while RX
Q19,20	DC switch	SB switch, active when powering up
Q21	DC switch	Active while PS voltage is more than 20V
Q22	RF amplifier	Predrive

Ref. No.	Use/Function	Operation/Condition
Q23	DC switch	SB switch, active when powering up
Q24	AF mute	Active while power switch is off
Q25	RF amplifier	Drive
Q26	Inverter	Active while power switch is low
Q27	L.N.A.	
Q28	DC switch	8T, active while TX
Q29	DC switch	8T cont, active while TX
Q31	APC controller	
Q32	APC controller	DB
Q33	APC controller	Power protection
Q36	DC switch	Power protection
Q37	AF mute switch	Inactive on mute
Q38	DC switch	5S
Q39	DC switch	Output enable
Q501	Clock switch shift	Clock shift is on while BSHIFT is H
Q502	AF mute	Active while MUTE is H
Q503	Inverter	Active while PA2 is H, active while public address
Q504	LED switch (Red)	Active while LED0 is H, active while TX
Q505,506	Key backlight switch	Active while MBL is H
Q508	LED switch (Green)	Active while LED1 is H, active while RX
Q509	MIC mute	Active while MM is H and MM2 is H

PLL/VCO (X58-4670-10)

Ref. No.	Use/Function	Operation/Condition
D101	RX VCO	
D102	TX VCO	
D103	RX VCO	
D104	TX VCO	
D105	Modulation	
Q101	Oscillator	RX
Q102	Inverter	Active while ST is H
Q103	Oscillator	TX
Q104	TX/RX switch (TX)	Active while ST is H
Q105	TX/RX switch (RX)	Active while Q102 is off
Q106	Buffer amplifier	

PARTS LIST

CAPACITORS

CC 45 TH 1H 220 J
 1 2 3 4 5 6

- 1 = Type ... ceramic, electrolytic, etc.
- 2 = Shape ... round, square, ect.
- 3 = Temp. coefficient
- 4 = Voltage rating
- 5 = Value
- 6 = Tolerance

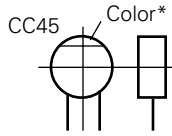

• Capacitor value

- 010 = 1pF
- 100 = 10pF
- 101 = 100pF
- 102 = 1000pF = 0.001μF
- 103 = 0.01μF

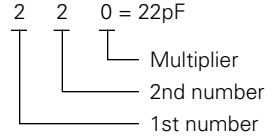

• Temperature coefficient

1st Word	C	L	P	R	S	T	U
Color*	Black	Red	Orange	Yellow	Green	Blue	Violet
ppm/°C	0	-80	-150	-220	-330	-470	-750

2nd Word	G	H	J	K	L
ppm/°C	±30	±60	±120	±250	±500

Example : CC45TH = -470 ± 60ppm/°C

• Tolerance (More than 10pF)

Code	C	D	G	J	K	M	X	Z	P	No code
(%)	±0.25	±0.5	±2	±5	±10	±20	+40 -20	+80 -20	+100 -0	More than 10μF -10 ~ +50 Less than 4.7μF -10 ~ +75

(Less than 10pF)

Code	B	C	D	F	G
(pF)	±0.1	±0.25	±0.5	±1	±2

• Voltage rating

2nd word \ 1st word	A	B	C	D	E	F	G	H	J	K	V
0	1.0	1.25	1.6	2.0	2.5	3.15	4.0	5.0	6.3	8.0	-
1	10	12.5	16	20	25	31.5	40	50	63	80	35
2	100	125	160	200	250	315	400	500	630	800	-
3	1000	1250	1600	2000	2500	3150	4000	5000	6300	8000	-

• Chip capacitors

(EX) C C 7 3 F S L 1 H 0 0 0 J
 1 2 3 4 5 6 7

(Chip) (CH, RH, UJ, SL)

(EX) C K 7 3 F F 1 H 0 0 0 Z
 1 2 3 4 5 6 7

(Chip) (B, F)

Refer to the table above.

- 1 = Type
- 2 = Shape
- 3 = Dimension
- 4 = Temp. coefficient
- 5 = Voltage rating
- 6 = Value
- 7 = Tolerance

Dimension (Chip capacitors)

Dimension code	L	W	T
Empty	5.6 ± 0.5	5.0 ± 0.5	Less than 2.0
A	4.5 ± 0.5	3.2 ± 0.4	Less than 2.0
B	4.5 ± 0.5	2.0 ± 0.3	Less than 2.0
C	4.5 ± 0.5	1.25 ± 0.2	Less than 1.25
D	3.2 ± 0.4	2.5 ± 0.3	Less than 1.5
E	3.2 ± 0.2	1.6 ± 0.2	Less than 1.25
F	2.0 ± 0.3	1.25 ± 0.2	Less than 1.25
G	1.6 ± 0.2	0.8 ± 0.2	Less than 1.0
H	1.0 ± 0.05	0.5 ± 0.05	0.5 ± 0.05

RESISTORS

• Chip resistor (Carbon)

(EX) R D 7 3 E B 2 B 0 0 0 J
 1 2 3 4 5 6 7

(Chip) (B, F)

• Carbon resistor (Normal type)

(EX) R D 1 4 B B 2 C 0 0 0 J
 1 2 3 4 5 6 7

- 1 = Type ... ceramic, electrolytic, etc.
- 2 = Shape ... round, square, ect.
- 3 = Dimension
- 4 = Temp. coefficient
- 5 = Voltage rating
- 6 = Value
- 7 = Tolerance

Dimension

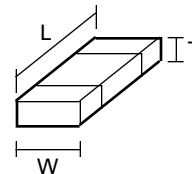

Dimension (Chip resistor)

Dimension code	L	W	T
E	3.2 ± 0.2	1.6 ± 0.2	1.0
F	2.0 ± 0.3	1.25 ± 0.2	1.0
G	1.6 ± 0.2	0.8 ± 0.2	0.5 ± 0.1
H	1.0 ± 0.05	0.5 ± 0.05	0.35 ± 0.05

Rating wattage

Code	Wattage	Code	Wattage	Code	Wattage
1J	1/16W	2C	1/6W	3A	1W
2A	1/10W	2E	1/4W	3D	2W
2B	1/8W	2H	1/2W		

TK-760G/(N)/762G/(N)

PARTS LIST

*New Parts. ⚠ indicates safety critical components.

Parts without **Parts No.** are not supplied.

Les articles non mentionnés dans le **Parts No.** ne sont pas fournis.

Teile ohne **Parts No.** werden nicht geliefert.

L : Scandinavia

K : USA

P : Canada

Y : PX (Far East, Hawaii)

T : England

E : Europe

Y : AAFES (Europe)

X : Australia

M : Other Areas

TK-760G/(N)/762G/(N), DISPLAY UNIT (X54-3270-10) : TK-760G/(N)

DISPLAY UNIT (X54-3280-10) : TK-762G/(N)

Ref. No.	Address	New parts	Parts No.	Description	Destination
TK-760G/(N)/762G/(N)					
1	1B,1E		A01-2165-13	CABINET UPPER	
2	2A,2D		A01-2166-13	CABINET LOWER	
3	2A		A62-0642-03	PANEL ASSY	760
3	2D		A62-0731-03	PANEL ASSY	762
5	1G		B09-0235-05	CAP	
6	2B		B11-1226-03	ILLUMINATION GUIDE	760
6	2E		B11-1230-03	ILLUMINATION GUIDE	762
7	2A		B38-0824-05	LCD	760
7	2E		B38-0825-05	LCD	762
8	2G		B62-1439-10	INSTRUCTION MANUAL	
9	1C,1F		B72-1667-04	MODEL NAME PLATE	NE
9	1C		B72-1779-14	MODEL NAME PLATE	760NE
9	1F	*	B72-1780-24	MODEL NAME PLATE	762E
9	1F		B72-1781-14	MODEL NAME PLATE	762NE
9	1C		B72-1903-04	MODEL NAME PLATE	760E
11	2B		E29-1179-04	INTER CONNECTOR	760
11	2Z		E29-1183-04	INTER CONNECTOR	762
13	1G		E30-3339-05	DC CORD ACC	
14	1C,1F		E30-3340-05	DC CORD RADIO	
-			E30-3404-05	EXTENSION CABLE	
12	1C,1F		E30-3405-05	ANTENNA CABLE	
16	1C,1F		E37-0790-25	LEAD WIRE WITH CONNECTOR (SP)	
17	2B,2E		E37-0815-05	FLAT CABLE	
19	1G		F51-0016-05	FUSE (6*30) 10A	
21	1C,1F		G02-0791-04	FLAT SPRING AF,APC	
-			G02-0862-14	EARTH SPRING	
22	1B,1E		G10-1221-04	FIBROUS SHEET SIDE	
23	1B,1E		G10-1222-14	FIBROUS SHEET UP,DOWN	
24	1A,1D		G10-1223-14	FIBROUS SHEET SHIELD	
25	1C,1F		G13-1468-04	CUSHION DC CORD	
26	1B,1E		G13-1759-04	CUSHION SP	
27	2C,2F		G53-0796-04	PACKING PHONE JACK	
28	2E		G53-0889-04	PACKING DISPLAY UNIT	762
30	3G		H10-6618-12	POLYSTYRENE FOAMED FIXTURE (F)	
31	2H		H10-6619-12	POLYSTYRENE FOAMED FIXTURE (R)	
32	1G		H12-1391-03	INNER PACKING CASE	
33	1H,2H		H25-0720-04	PROTECTION BAG (200X350)	
34	3H		H52-1519-02	ITEM CARTON CASE	
36	2G		J19-1584-05	HOLDER ACC	
37	2A,2D		J21-8382-03	HARDWARE FIXTURE	
38	1G		J29-0627-23	BRACKET	
40	2A		K29-5343-02	KEY TOP	760
40	1D		K29-5344-02	KEY TOP	762
A	2A,2D		N33-2606-45	OVAL HEAD MACHINE SCREW	
B	2C,2F		N67-3008-46	PAN HEAD SEMS SCREW W	
C	2B,2E		N87-2606-46	BRAZIER HEAD TAPTITE SCREW	
D	2B,2E		N87-2612-46	BRAZIER HEAD TAPTITE SCREW	
42	2G		N99-0395-05	SCREW SET	
44	1B,1E		T07-0368-05	SPEAKER	

Ref. No.	Address	New parts	Parts No.	Description	Destination
DISPLAY UNIT (X54-3270-10) : TK-760G/(N)					
D802-805		*	B30-2220-05	LED (2P/YELLOW)	
C801-803			CC73GCH1H101J	CHIP C 100PF J	
C804			CK73GF1A105Z	CHIP C 1.0UF Z	
C805			CK73GB1H102K	CHIP C 1000PF K	
C806,807			CK73GB1H471K	CHIP C 470PF K	
CN801			E40-6020-05	PIN ASSY	
L801			L92-0138-05	FERRITE CHIP	
R801-803			RK73GB1J103J	CHIP R 10K J 1/16W	
R804			RK73GB1J473J	CHIP R 47K J 1/16W	
R805			RK73GB1J474J	CHIP R 470K J 1/16W	
R806			R92-1252-05	CHIP R 0 OHM	
R808			RK73GB1J392J	CHIP R 3.9K J 1/16W	
R809			RK73FB2A270J	CHIP R 27 J 1/10W	
D801			MA2S111	DIODE	
D808			HSB123	DIODE	
IC801			LC75823W	IC (LCD DRIVER)	
Q801			2SB1132(Q,R)	TRANSISTOR	
DISPLAY UNIT (X54-3280-10) : TK-762G/(N)					
D801			B30-2204-05	LED (RED/YELLOW)	
D803			B30-2220-05	LED (2P/YELLOW)	
D804			B30-2204-05	LED (RED/YELLOW)	
C801			CK73GB1H471K	CHIP C 470PF K	
C802-804			CC73GCH1H101J	CHIP C 100PF J	
C805			CK73GF1A105Z	CHIP C 1.0UF Z	
C806			CK73GB1H471K	CHIP C 470PF K	
C807			CK73GB1H102K	CHIP C 1000PF K	
C808			CK73GB1H471K	CHIP C 470PF K	
C812			CK73GB1H471K	CHIP C 470PF K	
CN801			E40-6020-05	PIN ASSY	
L801			L92-0138-05	FERRITE CHIP	
R801,802			RK73GB1J103J	CHIP R 10K J 1/16W	
R803			RK73FB2A123J	CHIP R 12K J 1/10W	
R804			RK73GB1J103J	CHIP R 10K J 1/16W	
R805			RK73FB2A332J	CHIP R 3.3K J 1/10W	
R806			RK73GB1J474J	CHIP R 470K J 1/16W	
R807			R92-1252-05	CHIP R 0 OHM	
R808			RK73GB1J393J	CHIP R 39K J 1/16W	
R809			RK73FB2A123J	CHIP R 12K J 1/10W	
R810			RK73FB2A332J	CHIP R 3.3K J 1/10W	
R812			RK73FB2A561J	CHIP R 560 J 1/10W	
R813-816			RK73GB1J473J	CHIP R 47K J 1/16W	
D802			MA2S111	DIODE	
IC801			LC75833W	IC (LCD DRIVER)	
Q801-803			DTA114EKA	DIGITAL TRANSISTOR	
Q804			KRA225S	DIGITAL TRANSISTOR	
Q805			DTA114EKA	DIGITAL TRANSISTOR	
Q806-809			2SK1824	FET	

PARTS LIST

TX-RX UNIT (X57-595X-XX)

Ref. No.	Address	New parts	Parts No.	Description	Desti-nation	Ref. No.	Address	New parts	Parts No.	Description	Desti-nation
TX-RX UNIT (X57-595X-XX)											
2-71 : TK-760G(N) 2-72 : TK-762G(N) 2-73 : TK-762G 2-74 : TK-760G											
D509-514			B30-2050-05	LED		C97			C92-0546-05	CHIP-TAN	68UF 6.3WV
D521			B30-2151-05	LED (RED/GREEN)		C98			CK73GB1H103K	CHIP C	0.010UF K
C1-11			CK73GB1H102K	CHIP C	1000PF K	C99			C92-0004-05	CHIP-TAN	1.0UF 16WV
C13-19			CK73GB1H102K	CHIP C	1000PF K	C100			CK73GB1H102K	CHIP C	1000PF K
C20			C92-0507-05	CHIP-TAN	4.7UF 6.3WV	C101			CC73GCH1H040C	CHIP C	4.0PF C
C21			CK73GB1H102K	CHIP C	1000PF K	C102,103			CK73GB1H102K	CHIP C	1000PF K
C22			CK73GB1C104K	CHIP C	0.10UF K	C104			C92-0002-05	CHIP-TAN	0.22UF 35WV
C23,24			C92-0507-05	CHIP-TAN	4.7UF 6.3WV	C105			CK73GB1H102K	CHIP C	1000PF K
C26			CK73GB1H102K	CHIP C	1000PF K	C106			CC73GCH1H180J	CHIP C	18PF J
C29			C92-0507-05	CHIP-TAN	4.7UF 6.3WV	C107			CK73GB1H102K	CHIP C	1000PF K
C30			CC73GCH1H050C	CHIP C	5.0PF C	C110			CC73GCH1H180J	CHIP C	18PF J
C31			CK73GB1H102K	CHIP C	1000PF K	C111			CC73GCH1H040C	CHIP C	4.0PF C
C32			C92-0662-05	CHIP-TAN	15UF 6.3WV	C112			CK73GB1H102K	CHIP C	1000PF K
C33			CC73GCH1H220J	CHIP C	22PF J	C113			C92-0507-05	CHIP-TAN	4.7UF 6.3WV
C35			CK73GB1C104K	CHIP C	0.10UF K	C114			C92-0697-05	CHIP-TAN	3.3UF 16WV
C36			CK73GB1H102K	CHIP C	1000PF K	C115			CK73GB1H102K	CHIP C	1000PF K
C37			CK73FB1C334K	CHIP C	0.33UF K	C116			CK73GB1H103K	CHIP C	0.010UF K
C40,41			CK73GB1H103K	CHIP C	0.010UF K	C117			CK73GB1H102K	CHIP C	1000PF K
C43			C92-0507-05	CHIP-TAN	4.7UF 6.3WV	C118			CC73GCH1H100D	CHIP C	10PF D
C44			CK73GB1H331K	CHIP C	330PF K	C119			CK73GB1H103K	CHIP C	0.010UF K
C45			CK73GB1H102K	CHIP C	1000PF K	C120			CC73GCH1H220J	CHIP C	22PF J
C46			CK73GB1H103K	CHIP C	0.010UF K	C121			CK73GB1H102K	CHIP C	1000PF K
C47			C92-0561-05	CHIP-ELE	22UF 16WV	C122,123			CK73GB1C104K	CHIP C	0.10UF K
C49			CK73GB1H102K	CHIP C	1000PF K	C124			CC73GCH1H101J	CHIP C	100PF J
C50			CC73GCH1H220J	CHIP C	22PF J	C125			C92-0004-05	CHIP-TAN	1.0UF 16WV
C51			CK73GB1C104K	CHIP C	0.10UF K	C126			CC73GCH1H120J	CHIP C	12PF J
C52			CC73GCH1H680J	CHIP C	68PF J	C127			CK73GB1H103K	CHIP C	0.010UF K
C53			CK73GB1C104K	CHIP C	0.10UF K	C128			C92-0543-05	CHIP-TAN	3.3UF 10WV
C54			CK73GB1H103K	CHIP C	0.010UF K	C129			CK73FF1C105Z	CHIP C	1.0UF Z
C56			CC73GCH1H220J	CHIP C	22PF J	C130			CK73GB1H103K	CHIP C	0.010UF K
C58			CK73GB1E223K	CHIP C	0.022UF K	C131-133			CK73GB1H102K	CHIP C	1000PF K
C60,61			CK73GB1H102K	CHIP C	1000PF K	C134			CK73FB1E104K	CHIP C	0.10UF K
C62			CC73GCH1H101J	CHIP C	100PF J	C135			CC73GCH1H070B	CHIP C	7.0PF B
C63			CK73GB1C104K	CHIP C	0.10UF K	C136			CC73GCH1H080D	CHIP C	8.0PF D
C64			CK73GB1H103K	CHIP C	0.010UF K	C136			CK73GB1C104K	CHIP C	0.10UF K
C66,67			CK73GB1H102K	CHIP C	1000PF K	C137			CC73GCH1H101J	CHIP C	100PF J
C69			CK73GB1E223K	CHIP C	0.022UF K	C138			CK73FB1E104K	CHIP C	0.10UF K
C70			C92-0507-05	CHIP-TAN	4.7UF 6.3WV	C139			CK73GB1H102K	CHIP C	1000PF K
C72			C92-0507-05	CHIP-TAN	4.7UF 6.3WV	C141			C92-0719-05	ELECTRO	47UF 25WV
C74,75			CK73GB1H102K	CHIP C	1000PF K	C142-144			CK73GB1H102K	CHIP C	1000PF K
C77			C90-2046-05	ELECTRO	22UF 10WV	C146-149			CK73GB1H102K	CHIP C	1000PF K
C78			CK73GB1H102K	CHIP C	1000PF K	C150			CK73FF1C105Z	CHIP C	1.0UF Z
C79,80			CK73GB1H221K	CHIP C	220PF K	C151			CK73GB1H102K	CHIP C	1000PF K
C81			CK73GB1H102K	CHIP C	1000PF K	C152			CC73GCH1H040C	CHIP C	4.0PF C
C82			C92-0507-05	CHIP-TAN	4.7UF 6.3WV	C153			CC73GCH1H030C	CHIP C	3.0PF C
C83			CC73GCH1H270J	CHIP C	27PF J	C154			CK73GB1H102K	CHIP C	1000PF K
C84			C92-0507-05	CHIP-TAN	4.7UF 6.3WV	C155			CC73GCH1H080D	CHIP C	8.0PF D
C86			C92-0662-05	CHIP-TAN	15UF 6.3WV	C156,157			CK73GB1H102K	CHIP C	1000PF K
C87			CC73GCH1H330J	CHIP C	33PF J	C158			CC73GCH1H390J	CHIP C	39PF J
C88			CK73GB1H103K	CHIP C	0.010UF K	C159			CC73GCH1H180J	CHIP C	18PF J
C91			CC73GCH1H050C	CHIP C	5.0PF C	C160,161			C92-0719-05	ELECTRO	47UF 25WV
C92			CK73GB1H102K	CHIP C	1000PF K	C162			CK73GB1H102K	CHIP C	1000PF K
C93			C92-0555-05	CHIP-TAN	0.047UF 35WV	C163			CC73GCH1H020B	CHIP C	2.0PF B
C94			CK73GB1H102K	CHIP C	1000PF K	C164			CK73GB1H102K	CHIP C	1000PF K
C95			CC73GCH1H020B	CHIP C	2.0PF B	C165			C92-0719-05	ELECTRO	47UF 25WV
C96			CK73GB1H102K	CHIP C	1000PF K	C166			CE04EW1E471M	ELECTRO	470UF 25WV
						C167			CC73GCH1H100D	CHIP C	10PF D
						C168-170			CK73GB1H102K	CHIP C	1000PF K
						C171			CC73GCH1H020B	CHIP C	2.0PF B
						C172			CE04EW1E471M	ELECTRO	470UF 25WV

E
NE

TK-760G/(N)/762G/(N)

PARTS LIST

TX-RX UNIT (X57-595X-XX)

Ref. No.	Address	New parts	Parts No.	Description	Destination	Ref. No.	Address	New parts	Parts No.	Description	Destination
C173			CK73GB1C104K	CHIP C 0.10UF K		C520			CK73GB1C104K	CHIP C 0.10UF K	
C174			CK73GB1H102K	CHIP C 1000PF K		C521			CK73GB1H102K	CHIP C 1000PF K	
C175			CC73GCH1H070D	CHIP C 7.0PF D		C522			C92-0507-05	CHIP-TAN 4.7UF 6.3WV	
C177			CK73GB1H102K	CHIP C 1000PF K		C523			CC73GCH1H221J	CHIP C 220PF J	
C179			CK73GB1H102K	CHIP C 1000PF K		C524			CK73GB1H103K	CHIP C 0.010UF K	
C180			CK73GB1H103K	CHIP C 0.010UF K		C525			CK73GB1E123K	CHIP C 0.012UF K	
C181			CC73FCH1H120J	CHIP C 12PF J		C526			CK73GB1C683K	CHIP C 0.068UF K	
C183			CK73GB1H102K	CHIP C 1000PF K		C527			CK73GB1H222K	CHIP C 2200PF K	
C184			CK73FB1E104K	CHIP C 0.10UF K		C528			CK73GB1H103K	CHIP C 0.010UF K	
C185			CK73GB1C104K	CHIP C 0.10UF K		C529			CK73GB1H272K	CHIP C 2700PF K	
C186,187			CK73GB1H102K	CHIP C 1000PF K		C530			CK73GB1H152K	CHIP C 1500PF K	
C189,190			CK73GB1H102K	CHIP C 1000PF K		C531			CK73GB1H272K	CHIP C 2700PF K	
C192			CK73GB1H102K	CHIP C 1000PF K		C532,533			CK73GB1C104K	CHIP C 0.10UF K	
C194			CK73GB1C104K	CHIP C 0.10UF K		C534,535			CK73GB1H103K	CHIP C 0.010UF K	
C195			C92-0719-05	ELECTRO 47UF 25WV		C536,537			CK73GB1C104K	CHIP C 0.10UF K	
C196			CK73GB1H102K	CHIP C 1000PF K		C538			C92-0566-05	CHIP-TAN 10UF 6.3WV	
C198			CK73GB1H102K	CHIP C 1000PF K		C539			CK73GB1H103K	CHIP C 0.010UF K	
C200			CK73GB1H102K	CHIP C 1000PF K		C540,541			CK73GB1C104K	CHIP C 0.10UF K	
C201			CK73GB1C104K	CHIP C 0.10UF K		C542			CC73GCH1H331J	CHIP C 330PF J	
C203			CK73GB1H102K	CHIP C 1000PF K		C543			CK73GB1H102K	CHIP C 1000PF K	
C204			C92-0004-05	CHIP-TAN 1.0UF 16WV		C544-546			CK73GB1H562K	CHIP C 5600PF K	
C205			C93-0560-05	CHIP C 10PF D		C547			CC73GCH1H030C	CHIP C 3.0PF C	
C207			CK73GB1H103K	CHIP C 0.010UF K		C548-550			CK73GB1H272K	CHIP C 2700PF K	
C208			CC73FCH1H040C	CHIP C 4.0PF C		C551			CC73GCH1H151J	CHIP C 150PF J	
C209			C93-0564-05	CHIP C 22PF J		C552			CC73GCH1H030C	CHIP C 3.0PF C	
C210			CK73GB1H103K	CHIP C 0.010UF K		C553			CK73GB1H102K	CHIP C 1000PF K	
C211			C93-0564-05	CHIP C 22PF J		C554			CK73GB1H122K	CHIP C 1200PF K	
C212			CK73GB1H102K	CHIP C 1000PF K		C555			C92-0566-05	CHIP-TAN 10UF 6.3WV	
C213			C93-0563-05	CHIP C 18PF J		C556			CK73GB1C333K	CHIP C 0.033UF K	
C214			C93-0603-05	CHIP C 1000PF K		C557			CK73GB1C104K	CHIP C 0.10UF K	
C215			C93-0561-05	CHIP C 12PF J		C558			CC73GCH1H101J	CHIP C 100PF J	
C216			CC73GCH1H0R5B	CHIP C 0.5PF B		C559			CK73GB1H102K	CHIP C 1000PF K	
C217			CC73GCH1H010B	CHIP C 1.0PF B		C560-563			CK73GB1C104K	CHIP C 0.10UF K	
C218			CK73GB1C104K	CHIP C 0.10UF K		C564			C92-0507-05	CHIP-TAN 4.7UF 6.3WV	
C219			C93-0565-05	CHIP C 27PF J		C565,566			CK73GB1H472K	CHIP C 4700PF K	
C220			CK73GB1H102K	CHIP C 1000PF K		C567			CC73GCH1H101J	CHIP C 100PF J	
C221			C93-0563-05	CHIP C 18PF J		C568			C92-0507-05	CHIP-TAN 4.7UF 6.3WV	
C222			CC73GCH1H0R5B	CHIP C 0.5PF B		C569			CK73GB1E223K	CHIP C 0.022UF K	
C223			CC73GCH1H010B	CHIP C 1.0PF B		C570			CK73FF1C105Z	CHIP C 1.0UF Z	
C224			CK73GB1H102K	CHIP C 1000PF K		C571,572			CK73GB1H102K	CHIP C 1000PF K	
C241			C93-0554-05	CHIP C 4.0PF C		C573			CK73FB1H563K	CHIP C 0.056UF K	
C248			C92-0585-05	CHIP-TAN 4.7UF 16WV		C574			CC73GCH1H470J	CHIP C 47PF J	
C259			CK73GB1C104K	CHIP C 0.10UF K		C575			CK73GB1H102K	CHIP C 1000PF K	
C270			CK73GB1C104K	CHIP C 0.10UF K		C576			CK73GB1C104K	CHIP C 0.10UF K	
C271			CK73GB1H472K	CHIP C 4700PF K		C577,578			CK73GB1H103K	CHIP C 0.010UF K	
C274			CK73GB1C104K	CHIP C 0.10UF K		C579			CC73GCH1H101J	CHIP C 100PF J	
C501			CK73GB1H102K	CHIP C 1000PF K		C580			CK73GB1C104K	CHIP C 0.10UF K	
C502			CK73GB1C104K	CHIP C 0.10UF K		C581			CK73GB1H102K	CHIP C 1000PF K	
C503			CK73GB1H471K	CHIP C 470PF K		C582			CK73GB1C473K	CHIP C 0.047UF K	
C504			CK73GB1H103K	CHIP C 0.010UF K		C583			C92-0566-05	CHIP-TAN 10UF 6.3WV	
C505			CK73GB1C104K	CHIP C 0.10UF K		C584			CK73GB1H103K	CHIP C 0.010UF K	
C506,507			CK73GB1H103K	CHIP C 0.010UF K		C585			CC73GCH1H101J	CHIP C 100PF J	
C508			CK73GB1H472K	CHIP C 4700PF K		C587			CK73GB1H103K	CHIP C 0.010UF K	
C509			C92-0507-05	CHIP-TAN 4.7UF 6.3WV		C589			C92-0606-05	CHIP-TAN 4.7UF 10WV	
C514			CC73GCH1H680J	CHIP C 68PF J		C590			CK73GB1H102K	CHIP C 1000PF K	
C515			CK73GB1H103K	CHIP C 0.010UF K		C594			CK73GB1H102K	CHIP C 1000PF K	
C516			CC73GCH1H270J	CHIP C 27PF J		C596			CK73GB1H102K	CHIP C 1000PF K	
C517			CK73GB1C683K	CHIP C 0.068UF K		C597			CC73GCH1H101J	CHIP C 100PF J	
C518			CC73GCH1H270J	CHIP C 27PF J		C598			CK73GB1H102K	CHIP C 1000PF K	
C519			CK73GB1H102K	CHIP C 1000PF K		C599			CC73GCH1H101J	CHIP C 100PF J	

PARTS LIST

TX-RX UNIT (X57-595X-XX)

Ref. No.	Address	New parts	Parts No.	Description	Desti-nation	Ref. No.	Address	New parts	Parts No.	Description	Desti-nation
C600			CK73GB1H102K	CHIP C 1000PF K		L26			L40-4775-77	SMALL FIXED INDUCTOR (47NH)	
C601,602			CC73GCH1H101J	CHIP C 100PF J		L27			L40-2281-86	SMALL FIXED INDUCTOR (0.22UH)	
C603			CK73GB1H102K	CHIP C 1000PF K		L33			L92-0179-05	FERRITE CHIP	
C604-606			CC73GCH1H101J	CHIP C 100PF J		L501			L92-0138-05	FERRITE CHIP	
C608-610			CC73GCH1H101J	CHIP C 100PF J		L503,504			L92-0138-05	FERRITE CHIP	
C611,612			CK73GB1H471K	CHIP C 470PF K		L507			L92-0140-05	FERRITE CHIP	
C613			CC73GCH1H101J	CHIP C 100PF J		L510			L92-0140-05	FERRITE CHIP	
C615			CK73GB1H471K	CHIP C 470PF K		X1			L77-1826-05	TCXO (16.8MHZ)	
C616			CC73GCH1H101J	CHIP C 100PF J		X501			L77-1708-05	CRYSTAL RESONATOR (3.579545MHZ)	
C618			CK73GB1H102K	CHIP C 1000PF K		X502			L78-0462-05	RESONATOR (9.8304MHZ)	
C620			CK73GB1H471K	CHIP C 470PF K		XF1	*		L71-0551-25	MCF (49.95MHZ)	
C621			CK73GB1H102K	CHIP C 1000PF K		CP501-505			R90-0741-05	MULTIPLE RESISTOR	
C623			CK73GB1H102K	CHIP C 1000PF K		CP508-514			R90-0741-05	MULTIPLE RESISTOR	
C626			CK73GB1C104K	CHIP C 0.10UF K		CP516-524			R90-0741-05	MULTIPLE RESISTOR	
C628			CK73GB1C104K	CHIP C 0.10UF K		CP526,527			R90-0741-05	MULTIPLE RESISTOR	
C629			CC73GCH1H470J	CHIP C 47PF J		CP529-536			R90-0741-05	MULTIPLE RESISTOR	
C630			C92-0507-05	CHIP-TAN 4.7UF 6.3WV		CP538			R90-0741-05	MULTIPLE RESISTOR	
C631			CK73GB1H103K	CHIP C 0.010UF K		CP539			R90-0724-05	MULTI-COMP 1K X4	
C632			CK73FF1C10SZ	CHIP C 1.0UF Z		R1			R92-1252-05	CHIP R 0 OHM	
C633			CK73GB1C104K	CHIP C 0.10UF K		R2			RK73GB1J102J	CHIP R 1.0K J 1/16W	
C640			C92-0507-05	CHIP-TAN 4.7UF 6.3WV		R3			R92-1252-05	CHIP R 0 OHM	
C707			CK73GB1H471K	CHIP C 470PF K		R4			RK73GB1J333J	CHIP R 33K J 1/16W	
C720			C92-0566-05	CHIP-TAN 10UF 6.3WV		R6			R92-1252-05	CHIP R 0 OHM	
CN1			E40-6047-05	PIN ASSY		R7,8			RK73GB1J102J	CHIP R 1.0K J 1/16W	
CN2			E40-6021-05	FLAT CABLE CONNECTOR		R9,10			R92-1252-05	CHIP R 0 OHM	
CN3			E40-3247-05	PIN ASSY		R11			RK73GB1J102J	CHIP R 1.0K J 1/16W	
CN4			E40-5737-05	PIN ASSY		R12			RK73GB1J104J	CHIP R 100K J 1/16W	
CN5			E40-5738-05	PIN ASSY		R13			RK73GB1J473J	CHIP R 47K J 1/16W	
CN7			E40-3247-05	PIN ASSY		R14			RK73GB1J474J	CHIP R 470K J 1/16W	
CN8			E40-3246-05	PIN ASSY		R15			RK73GB1J104J	CHIP R 100K J 1/16W	
CN501			E40-6021-05	FLAT CABLE CONNECTOR		R16			RK73GB1J220J	CHIP R 22 J 1/16W	
J1			E11-0442-05	3.5D PHONE JACK (3P)		R17			RK73GB1J154J	CHIP R 150K J 1/16W	
J501			E08-0877-05	MODULAR JACK		R18			RK73GB1J104J	CHIP R 100K J 1/16W	
F1			F53-0108-05	FUSE		R20			RK73GB1J224J	CHIP R 220K J 1/16W	
-			J31-0543-05	COLLAR		R21			RK73GB1J102J	CHIP R 1.0K J 1/16W	
CF2			L72-0959-05	CERAMIC FILTER	NE	R22			RK73GB1J474J	CHIP R 470K J 1/16W	
CF2			L72-0973-05	CERAMIC FILTER	E	R24			RK73GB1J183J	CHIP R 18K J 1/16W	
L1			L40-1005-34	SMALL FIXED INDUCTOR (10UH)		R25,26			R92-1252-05	CHIP R 0 OHM	
L2-4			L40-3381-86	SMALL FIXED INDUCTOR (0.33UH)		R28,29			R92-1252-05	CHIP R 0 OHM	
L5			L34-4530-05	COIL		R31			RK73GB1J152J	CHIP R 1.5K J 1/16W	
L6			L40-1581-86	SMALL FIXED INDUCTOR (0.15UH)		R33			R92-1252-05	CHIP R 0 OHM	
L7			L40-6885-34	SMALL FIXED INDUCTOR (680NH)		R34			RK73GB1J104J	CHIP R 100K J 1/16W	
L8			L40-8285-85	SMALL FIXED INDUCTOR (0.82UH)		R35			RK73GB1J224J	CHIP R 220K J 1/16W	
L9			L40-1085-77	SMALL FIXED INDUCTOR (100NH)		R36			RK73GB1J223J	CHIP R 22K J 1/16W	
L10			L40-8275-77	SMALL FIXED INDUCTOR (82NH)		R37			RK73GB1J220J	CHIP R 22 J 1/16W	
L11			L34-4472-05	COIL		R40			RK73GB1J103J	CHIP R 10K J 1/16W	
L12			L40-3375-34	SMALL FIXED INDUCTOR (33NH)		R41			RK73GB1J224J	CHIP R 220K J 1/16W	
L13			L34-4473-05	COIL		R42			RK73GB1J223J	CHIP R 22K J 1/16W	
L14			L40-6875-34	SMALL FIXED INDUCTOR (68NH)		R43			RK73GB1J683J	CHIP R 68K J 1/16W	
L15			L34-4473-05	COIL		R44			RK73GB1J153J	CHIP R 15K J 1/16W	
L17			L92-0179-05	FERRITE CHIP		R45			R92-1252-05	CHIP R 0 OHM	
L18			L34-4472-05	COIL		R47			RK73GB1J101J	CHIP R 100 J 1/16W	
L20			L34-4481-05	AIR-CORE COIL		R48			RK73GB1J184J	CHIP R 180K J 1/16W	
L21			L34-4478-05	AIR-CORE COIL		R49			RK73GB1J152J	CHIP R 1.5K J 1/16W	
L22			L34-4480-05	AIR-CORE COIL		R50			RK73GB1J473J	CHIP R 47K J 1/16W	
L23			L34-0742-05	AIR-CORE COIL		R51-53			RK73GB1J102J	CHIP R 1.0K J 1/16W	
L24			L34-4481-05	AIR-CORE COIL		R54			R92-1252-05	CHIP R 0 OHM	
L25			L34-4478-05	AIR-CORE COIL		R55			RK73GB1J104J	CHIP R 100K J 1/16W	
						R56			RK73GB1J101J	CHIP R 100 J 1/16W	

PARTS LIST

TX-RX UNIT (X57-595X-XX)

Ref. No.	Address	New parts	Parts No.	Description	Destination	Ref. No.	Address	New parts	Parts No.	Description	Destination
R57			RK73GB1J471J	CHIP R 470 J 1/16W		R124			RK73GB1J103J	CHIP R 10K J 1/16W	
R58			RK73GB1J332J	CHIP R 3.3K J 1/16W		R125			RK73GB1J333J	CHIP R 33K J 1/16W	
R59			RK73GB1J472J	CHIP R 4.7K J 1/16W		R126			RK73GB1J471J	CHIP R 470 J 1/16W	
R60			RK73GB1J334J	CHIP R 330K J 1/16W		R127			RK73GB1J222J	CHIP R 2.2K J 1/16W	
R61			RK73GB1J102J	CHIP R 1.0K J 1/16W		R128			RK73GB1J220J	CHIP R 22 J 1/16W	
R62			RK73GB1J224J	CHIP R 220K J 1/16W		R129			RK73GB1J152J	CHIP R 1.5K J 1/16W	
R63			RK73GB1J474J	CHIP R 470K J 1/16W		R130			RK73GB1J103J	CHIP R 10K J 1/16W	
R64			RK73GB1J223J	CHIP R 22K J 1/16W		R131			RK73GB1J681J	CHIP R 680 J 1/16W	
R65			RK73GB1J183J	CHIP R 18K J 1/16W		R132			RK73FB2A470J	CHIP R 47 J 1/10W	
R66			RK73GB1J101J	CHIP R 100 J 1/16W		R133-136			R92-1252-05	CHIP R 0 OHM	
R67			RK73GB1J472J	CHIP R 4.7K J 1/16W		R137			RK73FB2A100J	CHIP R 10 J 1/10W	
R68			RK73GB1J182J	CHIP R 1.8K J 1/16W		R138			RK73GB1J102J	CHIP R 1.0K J 1/16W	
R69			R92-1252-05	CHIP R 0 OHM		R139			RK73GB1J103J	CHIP R 10K J 1/16W	
R70			RK73GB1J562J	CHIP R 5.6K J 1/16W		R140			RK73FB2A2R2J	CHIP R 2.2 J 1/10W	
R71			RK73GB1J103J	CHIP R 10K J 1/16W		R141			RK73GB1J103J	CHIP R 10K J 1/16W	
R72			R92-1252-05	CHIP R 0 OHM		R142			RK73GB1J473J	CHIP R 47K J 1/16W	
R73			RK73GB1J223J	CHIP R 22K J 1/16W		R144			R92-0685-05	CHIP R 22 J 1/2W	
R75			RK73GB1J471J	CHIP R 470 J 1/16W		R145,146			RK73GB1J473J	CHIP R 47K J 1/16W	
R76			RK73GB1J223J	CHIP R 22K J 1/16W		R147			RK73GB1J102J	CHIP R 1.0K J 1/16W	
R77			RK73GB1J154J	CHIP R 150K J 1/16W		R148			RK73GB1J104J	CHIP R 100K J 1/16W	
R78			RK73GB1J104J	CHIP R 100K J 1/16W		R149			RK73GB1J470J	CHIP R 47 J 1/16W	
R79			RK73GB1J681J	CHIP R 680 J 1/16W		R150			RK73GB1J104J	CHIP R 100K J 1/16W	
R80			RK73GB1J471J	CHIP R 470 J 1/16W		R151			RK73FB2A331J	CHIP R 330 J 1/10W	
R81			RK73GB1J101J	CHIP R 100 J 1/16W		R152			R92-1252-05	CHIP R 0 OHM	
R82			RK73GB1J152J	CHIP R 1.5K J 1/16W		R153			R92-0670-05	CHIP R 0 OHM	
R83			RK73GB1J684J	CHIP R 680K J 1/16W		R154			RK73GB1J152J	CHIP R 1.5K J 1/16W	
R85			RK73GB1J272J	CHIP R 2.7K J 1/16W		R155			RK73FB2A150J	CHIP R 15 J 1/10W	
R86			RK73GB1J122J	CHIP R 1.2K J 1/16W		R157			RK73GB1J471J	CHIP R 470 J 1/16W	
R87			RK73GB1J102J	CHIP R 1.0K J 1/16W		R159			RK73GB1J473J	CHIP R 47K J 1/16W	
R88			RK73GB1J271J	CHIP R 270 J 1/16W		R160			RK73FB2A331J	CHIP R 330 J 1/10W	
R89			RK73GB1J102J	CHIP R 1.0K J 1/16W		R161			RK73GB1J334J	CHIP R 330K J 1/16W	
R90,91			RK73GB1J104J	CHIP R 100K J 1/16W		R162			RK73GB1J183J	CHIP R 18K J 1/16W	
R92			R92-1252-05	CHIP R 0 OHM		R163			R92-0670-05	CHIP R 0 OHM	
R93			RK73GB1J152J	CHIP R 1.5K J 1/16W		R164			R92-1213-05	CHIP R 100 J 1/2W	
R94			R92-1252-05	CHIP R 0 OHM		R166			RK73GB1J181J	CHIP R 180 J 1/16W	
R95			RK73GB1J103J	CHIP R 10K J 1/16W		R167			RK73GB1J330J	CHIP R 33 J 1/16W	
R97			RK73GB1J473J	CHIP R 47K J 1/16W		R168,169			RK73GB1J103J	CHIP R 10K J 1/16W	
R98			RK73GB1J223J	CHIP R 22K J 1/16W		R170			RK73FB2A222J	CHIP R 2.2K J 1/10W	
R99			RK73GB1J271J	CHIP R 270 J 1/16W		R171			RK73GB1J153J	CHIP R 15K J 1/16W	
R100,101			RK73GB1J101J	CHIP R 100 J 1/16W		R172			RK73GB1J334J	CHIP R 330K J 1/16W	
R103			RK73GB1J472J	CHIP R 4.7K J 1/16W		R173			RK73GB1J332J	CHIP R 3.3K J 1/16W	
R105			RK73GB1J470J	CHIP R 47 J 1/16W		R174			RK73GB1J103J	CHIP R 10K J 1/16W	
R106			RK73GB1J222J	CHIP R 2.2K J 1/16W		R175			RK73GB1J682J	CHIP R 6.8K J 1/16W	
R107			RK73GB1J473J	CHIP R 47K J 1/16W		R176			RK73GB1J104J	CHIP R 100K J 1/16W	
R108			RK73GB1J271J	CHIP R 270 J 1/16W		R177			R92-1261-05	CHIP R 150 J 1/2W	
R109			RK73GB1J102J	CHIP R 1.0K J 1/16W		R178			RK73GB1J103J	CHIP R 10K J 1/16W	
R110			RK73GB1J101J	CHIP R 100 J 1/16W		R179-181			RK73GB1J223J	CHIP R 22K J 1/16W	
R111			RK73GB1J180J	CHIP R 18 J 1/16W		R182			RK73GB1J102J	CHIP R 1.0K J 1/16W	
R112			RK73GB1J333J	CHIP R 33K J 1/16W		R183			R92-0670-05	CHIP R 0 OHM	
R113			RK73GB1J271J	CHIP R 270 J 1/16W		R184			R92-1252-05	CHIP R 0 OHM	
R114			RK73GB1J472J	CHIP R 4.7K J 1/16W		R185			RK73GB1J473J	CHIP R 47K J 1/16W	
R115			RK73GB1J103J	CHIP R 10K J 1/16W		R186			R92-1252-05	CHIP R 0 OHM	
R116			RK73GB1J473J	CHIP R 47K J 1/16W		R188			RK73GB1J102J	CHIP R 1.0K J 1/16W	
R117			RK73GB1J222J	CHIP R 2.2K J 1/16W		R189			RK73GB1J101J	CHIP R 100 J 1/16W	
R118			RK73GB1J102J	CHIP R 1.0K J 1/16W		R190			RK73GB1J473J	CHIP R 47K J 1/16W	
R119			RK73GB1J103J	CHIP R 10K J 1/16W		R192			RK73GB1J103J	CHIP R 10K J 1/16W	
R120			R92-1252-05	CHIP R 0 OHM		R193			RK73GB1J102J	CHIP R 1.0K J 1/16W	
R121			RK73GB1J100J	CHIP R 10 J 1/16W		R196			RK73GB1J332J	CHIP R 3.3K J 1/16W	
R122			R92-1215-05	CHIP R 470 J 1/2W		R197			R92-1252-05	CHIP R 0 OHM	
R123			RK73GB1J472J	CHIP R 4.7K J 1/16W		R201,202			R92-1252-05	CHIP R 0 OHM	

PARTS LIST

TX-RX UNIT (X57-595X-XX)

Ref. No.	Address	New parts	Parts No.	Description	Desti-nation	Ref. No.	Address	New parts	Parts No.	Description	Desti-nation
R203			RK73GB1J392J	CHIP R 3.9K J 1/16W	E	R566			RK73GB1J563J	CHIP R 56K J 1/16W	
R208			R92-0670-05	CHIP R 0 OHM		R567			RK73GB1J334J	CHIP R 330K J 1/16W	
R210			R92-1252-05	CHIP R 0 OHM		R568			RK73GB1J473J	CHIP R 47K J 1/16W	
R219			R92-1252-05	CHIP R 0 OHM		R569			RK73GB1J102J	CHIP R 1.0K J 1/16W	
R220			RK73GB1J680J	CHIP R 68 J 1/16W	NE	R570			RK73GB1J155J	CHIP R 1.5M J 1/16W	
R220			RK73GB1J820J	CHIP R 82 J 1/16W	E	R571			RN73GH1J682D	CHIP R 6.8K D 1/16W	
R221			R92-1252-05	CHIP R 0 OHM		R572			RK73GB1J473J	CHIP R 47K J 1/16W	
R501			RK73GB1J473J	CHIP R 47K J 1/16W		R573			RK73GB1J474J	CHIP R 470K J 1/16W	
R502			RK73GB1J472J	CHIP R 4.7K J 1/16W		R574			RN73GH1J683D	CHIP R 68K D 1/16W	
R503			RK73GB1J102J	CHIP R 1.0K J 1/16W		R575			RK73GB1J101J	CHIP R 100 J 1/16W	
R504-507			RK73GB1J473J	CHIP R 47K J 1/16W		R576			RK73GB1J224J	CHIP R 220K J 1/16W	
R508			RK73GB1J102J	CHIP R 1.0K J 1/16W		R577			RK73GB1J103J	CHIP R 10K J 1/16W	
R509,510			R92-1252-05	CHIP R 0 OHM		R578			RN73GH1J682D	CHIP R 6.8K D 1/16W	
R511			RK73GB1J473J	CHIP R 47K J 1/16W		R579			RK73GB1J223J	CHIP R 22K J 1/16W	
R512			RK73GB1J104J	CHIP R 100K J 1/16W		R580			R92-1252-05	CHIP R 0 OHM	
R513			RK73GB1J223J	CHIP R 22K J 1/16W		R581			RK73GB1J394J	CHIP R 390K J 1/16W	
R514			RK73GB1J473J	CHIP R 47K J 1/16W		R582			RK73GB1J273J	CHIP R 27K J 1/16W	
R515,516			RK73GB1J223J	CHIP R 22K J 1/16W		R583			RK73GB1J470J	CHIP R 47 J 1/16W	
R517			RK73GB1J473J	CHIP R 47K J 1/16W		R584			RK73GB1J220J	CHIP R 22 J 1/16W	
R518			RK73GB1J472J	CHIP R 4.7K J 1/16W		R585			R92-1252-05	CHIP R 0 OHM	
R519			RK73GB1J103J	CHIP R 10K J 1/16W		R586			RK73GB1J473J	CHIP R 47K J 1/16W	
R520-523			RK73GB1J102J	CHIP R 1.0K J 1/16W		R587			R92-1252-05	CHIP R 0 OHM	
R526			RK73GB1J154J	CHIP R 150K J 1/16W		R588			RK73GB1J103J	CHIP R 10K J 1/16W	
R527			R92-1252-05	CHIP R 0 OHM		R590			RK73GB1J333J	CHIP R 33K J 1/16W	
R528			RK73GB1J472J	CHIP R 4.7K J 1/16W		R591			R92-1252-05	CHIP R 0 OHM	
R529			RK73GB1J154J	CHIP R 150K J 1/16W		R592			RK73GB1J103J	CHIP R 10K J 1/16W	
R530			RK73GB1J473J	CHIP R 47K J 1/16W		R593			RK73GB1J181J	CHIP R 180 J 1/16W	
R531			RK73GB1J394J	CHIP R 390K J 1/16W		R594			RK73GB1J392J	CHIP R 3.9K J 1/16W	
R532			RK73GB1J103J	CHIP R 10K J 1/16W		R595			RK73GB1J181J	CHIP R 180 J 1/16W	
R533			RK73GB1J104J	CHIP R 100K J 1/16W		R598			RK73GB1J473J	CHIP R 47K J 1/16W	
R534			RK73GB1J823J	CHIP R 82K J 1/16W		R599			RK73GB1J102J	CHIP R 1.0K J 1/16W	
R535			RK73GB1J332J	CHIP R 3.3K J 1/16W		R600			R92-1252-05	CHIP R 0 OHM	
R536			RK73GB1J153J	CHIP R 15K J 1/16W		R602			RK73GB1J473J	CHIP R 47K J 1/16W	
R537			RK73GB1J105J	CHIP R 1.0M J 1/16W		R603			RK73GB1J101J	CHIP R 100 J 1/16W	
R538			RK73GB1J103J	CHIP R 10K J 1/16W		R604			RK73GB1J472J	CHIP R 4.7K J 1/16W	
R539			R92-1252-05	CHIP R 0 OHM		R605			RK73GB1J332J	CHIP R 3.3K J 1/16W	
R540			RK73GB1J223J	CHIP R 22K J 1/16W		R606			RK73GB1J102J	CHIP R 1.0K J 1/16W	
R541			RK73GB1J184J	CHIP R 180K J 1/16W		R607			RK73GB1J101J	CHIP R 100 J 1/16W	
R542			RK73GB1J102J	CHIP R 1.0K J 1/16W		R608			RK73GB1J122J	CHIP R 1.2K J 1/16W	
R543			RK73GB1J184J	CHIP R 180K J 1/16W		R610,611			RK73GB1J473J	CHIP R 47K J 1/16W	
R544			RK73GB1J103J	CHIP R 10K J 1/16W		R612			R92-1201-05	CHIP R 220 J 1/2W	
R545			RK73GB1J472J	CHIP R 4.7K J 1/16W		R613			RK73GB1J103J	CHIP R 10K J 1/16W	
R546			RN73GH1J913D	CHIP R 91K D 1/16W		R615			R92-1252-05	CHIP R 0 OHM	
R547			RK73GB1J103J	CHIP R 10K J 1/16W		R616			RK73GB1J474J	CHIP R 470K J 1/16W	
R548			RN73GH1J333D	CHIP R 33K D 1/16W		R617			RK73GB1J472J	CHIP R 4.7K J 1/16W	
R549			RN73GH1J913D	CHIP R 91K D 1/16W		R618			RK73GB1J683J	CHIP R 68K J 1/16W	
R550			RN73GH1J683D	CHIP R 68K D 1/16W		R619			RK73GB1J104J	CHIP R 100K J 1/16W	
R551,552			RK73GB1J223J	CHIP R 22K J 1/16W		R620,621			RK73GB1J103J	CHIP R 10K J 1/16W	
R553			RK73GB1J105J	CHIP R 1.0M J 1/16W		R622			RK73GB1J473J	CHIP R 47K J 1/16W	
R554			RN73GH1J913D	CHIP R 91K D 1/16W		R630			RK73GB1J102J	CHIP R 1.0K J 1/16W	
R555,556			RK73GB1J104J	CHIP R 100K J 1/16W		R701			RK73GB1J473J	CHIP R 47K J 1/16W	
R557			RN73GH1J274D	CHIP R 270K D 1/16W		R704			RK73GB1J223J	CHIP R 22K J 1/16W	
R558			R92-1252-05	CHIP R 0 OHM		R720			R92-1252-05	CHIP R 0 OHM	
R559			RK73GB1J103J	CHIP R 10K J 1/16W		R722			R92-1252-05	CHIP R 0 OHM	
R560			RK73GB1J154J	CHIP R 150K J 1/16W		D1			HSB123	DIODE	
R561			RK73GB1J333J	CHIP R 33K J 1/16W		D2			02DZ20(Y,Z)	ZENER DIODE	
R562			R92-1252-05	CHIP R 0 OHM		D3-5			HSB123	DIODE	
R563			RK73GB1J473J	CHIP R 47K J 1/16W		D9			1SS355	DIODE	
R564			RK73GB1J223J	CHIP R 22K J 1/16W		D11			MA742	DIODE	
R565			R92-1252-05	CHIP R 0 OHM							

TK-760G/(N)/762G/(N)

PARTS LIST

TX-RX UNIT (X57-595X-XX)

PLL/VCO (X58-4670-10)

Ref. No.	Address	New parts	Parts No.	Description	Destination	Ref. No.	Address	New parts	Parts No.	Description	Destination	
D14			1SS355	DIODE		Q7			2SC4649(N,P)	TRANSISTOR		
D15			DAN202K	DIODE		Q8			2SC2412K	TRANSISTOR		
D16			DAN235K	DIODE		Q9			2SC4215(Y)	TRANSISTOR		
D17			1SS355	DIODE		Q10			2SC2412K	TRANSISTOR		
D18			HVC350B	VARIABLE CAPACITANCE DIODE		Q11			2SA1832(GR)	TRANSISTOR		
D19,20			1SS355	DIODE		Q12			2SC4738(GR)	TRANSISTOR		
D21			02DZ18(X,Y)	ZENER DIODE		Q13,14			2SC4649(N,P)	TRANSISTOR		
D22			HSB123	DIODE		Q15			SGM2014AM	FET		
D23			HVC350B	VARIABLE CAPACITANCE DIODE		Q16			DTC114EKA	DIGITAL TRANSISTOR		
D24			02DZ15(X,Y)	ZENER DIODE		Q17			DTC363EU	DIGITAL TRANSISTOR		
D25			22ZR-10D	SURGE ABSORBER		Q18			2SA1745(6,7)	TRANSISTOR		
D27			1SS355	DIODE		Q19			DTC114EKA	DIGITAL TRANSISTOR		
D28			HVC350B	VARIABLE CAPACITANCE DIODE		Q20			DTA114EKA	DIGITAL TRANSISTOR		
D29			DSM3MA1	DIODE		Q21			DTC114EKA	DIGITAL TRANSISTOR		
D30,31			HVC350B	VARIABLE CAPACITANCE DIODE		Q22			2SC3357	TRANSISTOR		
D33		*	XB15A709	DIODE		Q23			2SA1641(S,T)	TRANSISTOR		
D34			MA4PH633	DIODE		Q24			DTA114EKA	DIGITAL TRANSISTOR		
D35,36			MA742	DIODE		Q25			2SC2954	TRANSISTOR		
D39			UDZ4.7(B)	ZENER DIODE		Q26			DTA114EKA	DIGITAL TRANSISTOR		
D40			MA742	DIODE		Q27			SGM2014AM	FET		
D41			HZU5ALL	DIODE		Q28			2SB1132(Q,R)	TRANSISTOR		
D501-504			MA2S111	DIODE	762	Q29			DTC114EKA	DIGITAL TRANSISTOR		
D505			MA2S111	DIODE		Q31			2SC2412K	TRANSISTOR		
D506,507			MA2S111	DIODE		Q32			2SB1565(E,F)	TRANSISTOR		
D508			MA742	DIODE		Q33			DTC114EKA	DIGITAL TRANSISTOR		
D523			DAN202U	DIODE		Q36			2SC2412K	TRANSISTOR		
D524,525			HSB123	DIODE		Q37,38			2SK1824	FET		
D526			1812L075PR	VARISTOR		Q501			2SC4619	TRANSISTOR		
D527,528			HSB123	DIODE		Q502,503			DTC114EE	DIGITAL TRANSISTOR		
D529			MA742	DIODE		Q504			2SC4617(S)	TRANSISTOR		
IC1,2			TA75S01F	IC (OP AMP)		Q505			2SB1132(Q,R)	TRANSISTOR		
IC3			MB15A02	IC (PLL IC)		Q506			DTC114EE	DIGITAL TRANSISTOR		
IC4			NJM4558M	IC (OP AMP X2)		Q508			2SC4617(S)	TRANSISTOR		
IC5			TA31136FN	IC (FM IF DETECTOR)		Q509			DTC363EU	DIGITAL TRANSISTOR		
IC6			M62363FP	IC (8BIT D/A CONVETER)		TH1			157-153-65001	THERMISTOR		
IC7			NJM2904M	IC (OP AMP X2)		PLL/VCO (X58-4670-10)						
IC8			UPB1509GV	IC		C102			CK73GB1H471K	CHIP C	470PF	K
IC9			BU4094BCF	IC (8-STAGE SHIFT/STORE REGISTER)		C104,105			CC73GCH1H150J	CHIP C	15PF	J
IC10			NJM78L05UA	IC (VOLTAGE REGULATOR/ +5V)		C107			CC73GCH1H080D	CHIP C	8.0PF	D
IC11			AN8009M	IC (REGULATOR)		C110			CC73GCH1H040B	CHIP C	4.0PF	B
IC12			TA7808S	IC (REGULATOR)		C111			CC73GCH1H050B	CHIP C	5.0PF	B
IC13			LA4422	IC (AF POWER AMP/ 5.8W)		C112,113			CC73GCH1H020B	CHIP C	2.0PF	B
IC14			TC4013BF(N)	IC (MEMORY)		C114,115			CC73GCH1H060D	CHIP C	6.0PF	D
IC15			TA75S01F	IC (OP AMP)		C116			CC73GCH1H120J	CHIP C	12PF	J
IC400	2C,2F		M67741H-32	IC (POWER MODULE)		C117			CK73GB1H471K	CHIP C	470PF	K
IC501			AT29C020-90TI	IC (ROM)		C118			CC73GCH1H050B	CHIP C	5.0PF	B
IC502			30622M4102GP	CPU		C119,120			CK73GB1H471K	CHIP C	470PF	K
IC503			RH5VL42C	IC (REGULATOR)		C121			CC73GCH1H090D	CHIP C	9.0PF	D
IC505			AT2408N10SI2.5	IC (8KBIT SERIAL EEPROM)		C122			CC73GCH1H0R5B	CHIP C	0.5PF	B
IC507			NJM2904V	IC (APC)		C123			CK73GB1H471K	CHIP C	470PF	K
IC508			TC35453F	IC (AUDIO PROCESSOR)		C124			CC73GCH1H0R5B	CHIP C	0.5PF	B
IC509			BU4066BCFV	IC (ANALOG SWITCH X4)		C125			CK73GB1H102K	CHIP C	1000PF	K
IC510			BU4094BCFV	IC (8BIT SHIFT/STORE REGISTER)		C126			CK73GB1H471K	CHIP C	470PF	K
IC511			LC73872M	IC (DTMF RECEIVER)		C127			CC73GCH1H100D	CHIP C	10PF	D
IC512			NJM78L05UA	IC (VOLTAGE REGULATOR)		TC106			C05-0384-05	CERAMIC TRIMMER CAP (10PF)		
IC513			TA75W558FU	IC (OP AMP X2)		TC109			C05-0384-05	CERAMIC TRIMMER CAP (10PF)		
IC514			TC75W51FU	IC (OP AMP X2)		CN101			E40-6019-05	PIN ASSY		
Q1			DTD114EK	DIGITAL TRANSISTOR								
Q2			KRA225S	DIGITAL TRANSISTOR								
Q5,6			DTC114EKA	DIGITAL TRANSISTOR								

PARTS LIST

PLL/VCO (X58-4670-10)

Ref. No.	Address	New parts	Parts No.	Description	Destination	Ref. No.	Address	New parts	Parts No.	Description	Destination
-			F10-2279-04	SHIELDING CASE							
L101-104			L40-1595-34	SMALL FIXED INDUCTOR (1.5UH)							
L105			L40-3975-34	SMALL FIXED INDUCTOR (39NH)							
L106			L40-2775-34	SMALL FIXED INDUCTOR (27NH)							
L107,108			L40-1098-76	SMALL FIXED INDUCTOR (1UH)							
L109,110			L40-1595-34	SMALL FIXED INDUCTOR (1.5UH)							
L111			L34-4547-05	AIR-CORE COIL							
L116			L34-4549-05	AIR-CORE COIL							
R101,102			RK73GB1J101J	CHIP R 100 J 1/16W							
R103			RK73GB1J102J	CHIP R 1.0K J 1/16W							
R104			RK73GB1J470J	CHIP R 47 J 1/16W							
R105			RK73GB1J154J	CHIP R 150K J 1/16W							
R106			RK73GB1J470J	CHIP R 47 J 1/16W							
R107-110			RK73GB1J103J	CHIP R 10K J 1/16W							
R111			RK73GB1J331J	CHIP R 330 J 1/16W							
R112,113			RK73GB1J181J	CHIP R 180 J 1/16W							
R114			RK73GB1J470J	CHIP R 47 J 1/16W							
R115			RK73GB1J103J	CHIP R 10K J 1/16W							
R116			RK73GB1J392J	CHIP R 3.9K J 1/16W							
R117			RK73GB1J101J	CHIP R 100 J 1/16W							
D101-104			1SV283	VARIABLE CAPACITANCE DIODE							
D105			HVU363A	DIODE							
Q101			2SK508NV(K52)	FET							
Q102			DTC114EUA	DIGITAL TRANSISTOR							
Q103			2SK508NV(K52)	FET							
Q104,105			2SC4081	TRANSISTOR							
Q106			2SC4226(R24)	TRANSISTOR							

TK-760G/(N)/762G/(N)

EXPLODED VIEW (TK-760G)

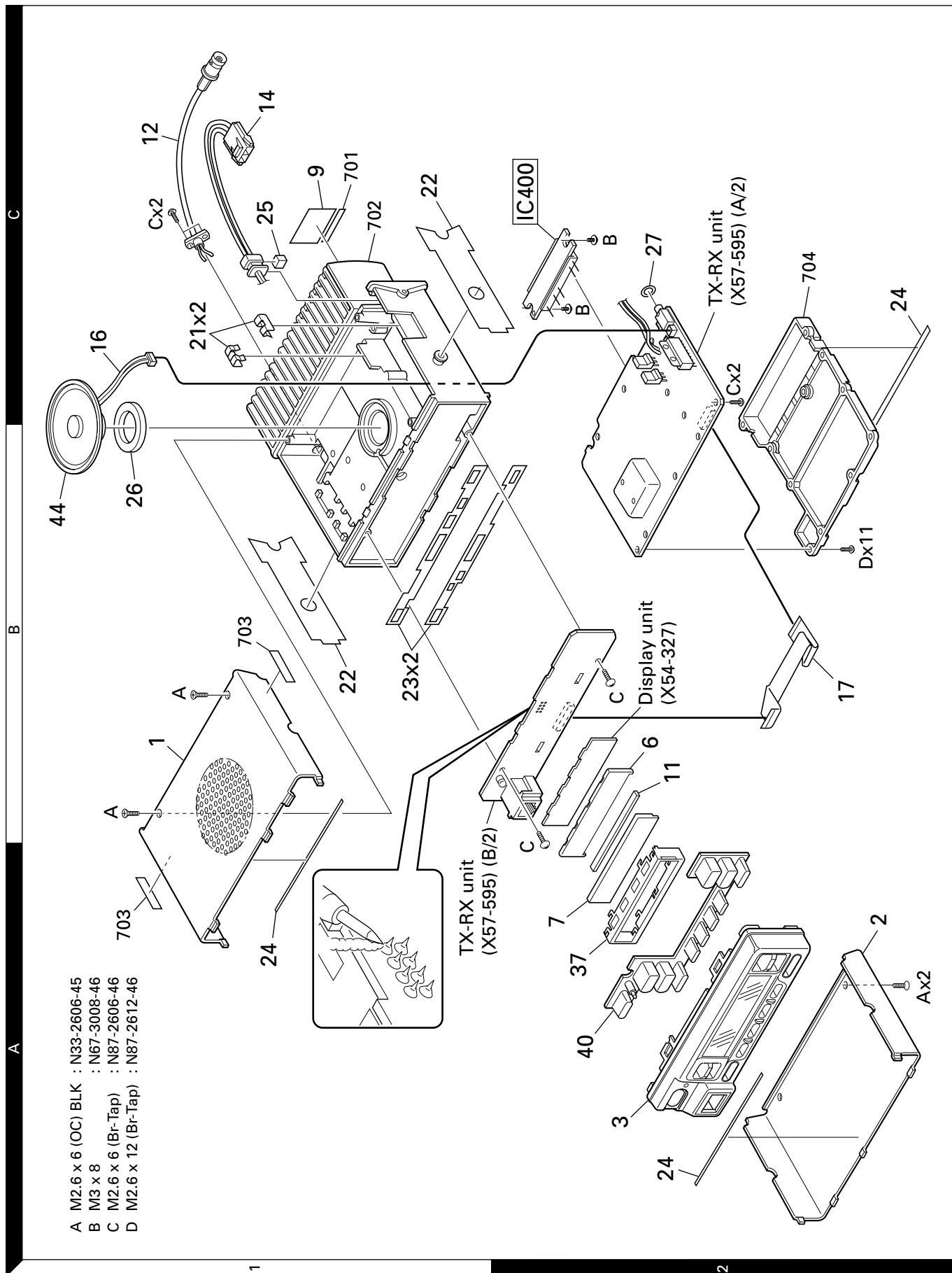

- A M2.6 x 6 (OC) BLK : N33-2606-45
- B M3 x 8 : N67-3008-46
- C M2.6 x 6 (Br-Tap) : N87-2606-46
- D M2.6 x 12 (Br-Tap) : N87-2612-46

EXPLODED VIEW (TK-762G)

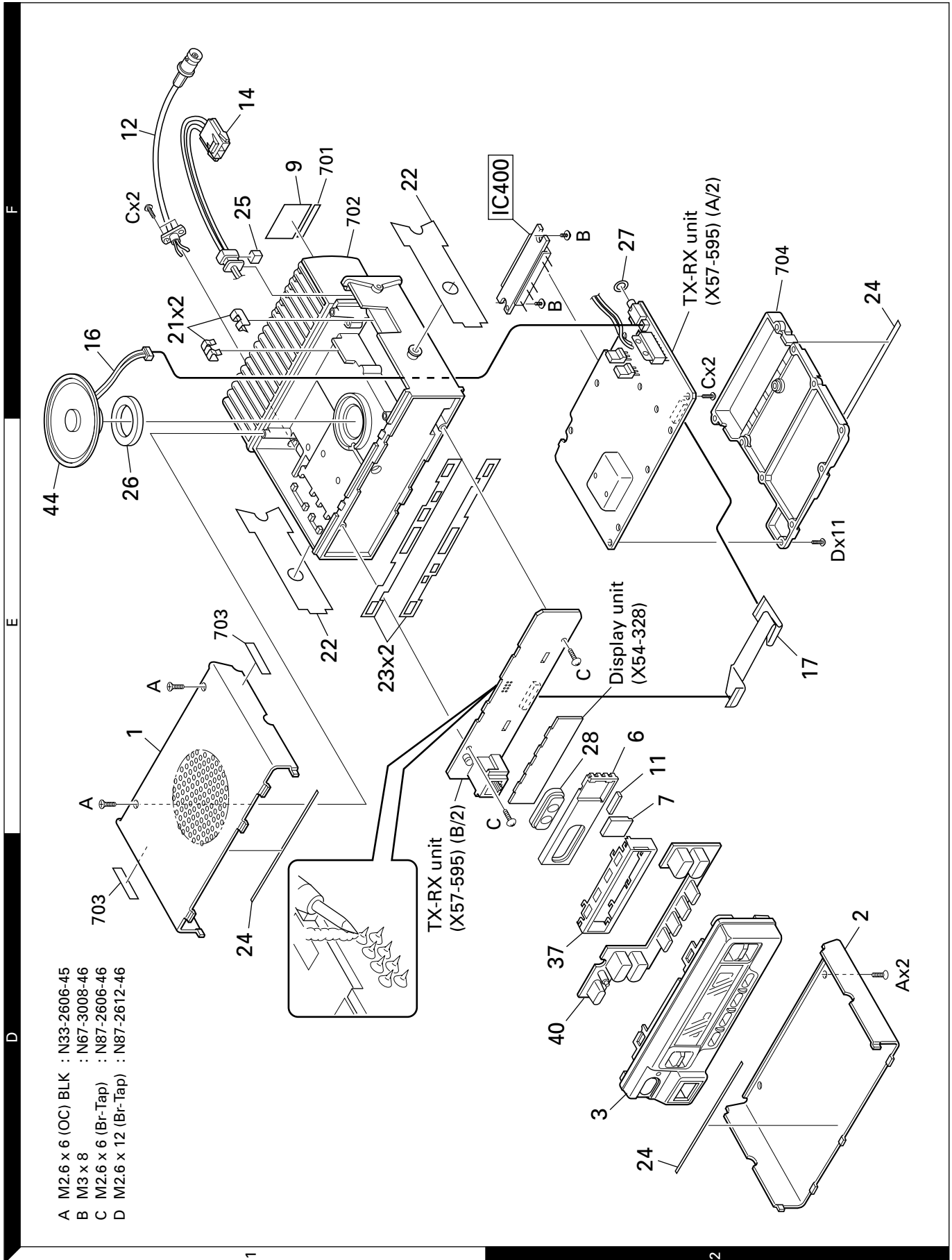

PACKING

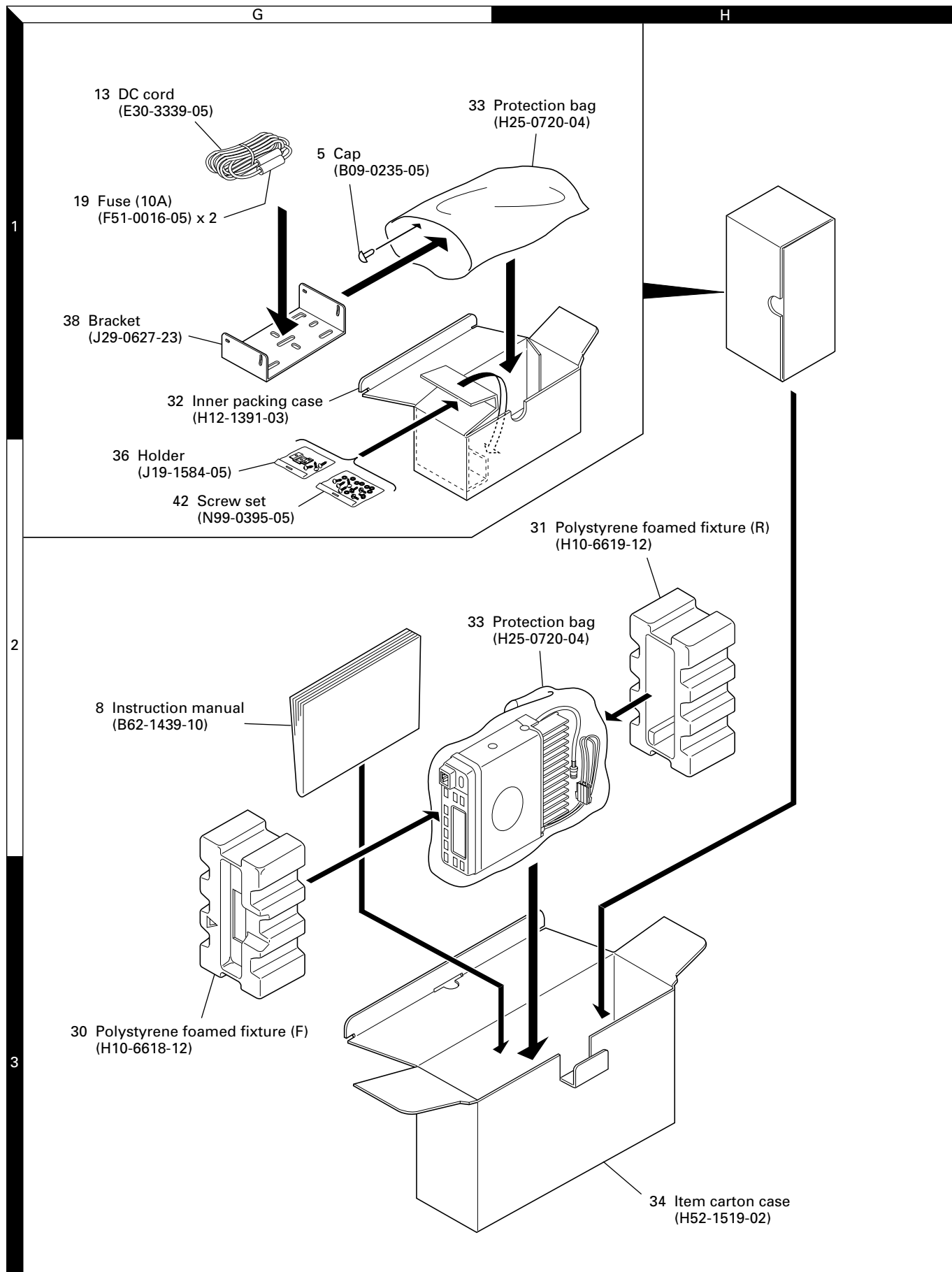

ADJUSTMENT

■ Tuning Mode

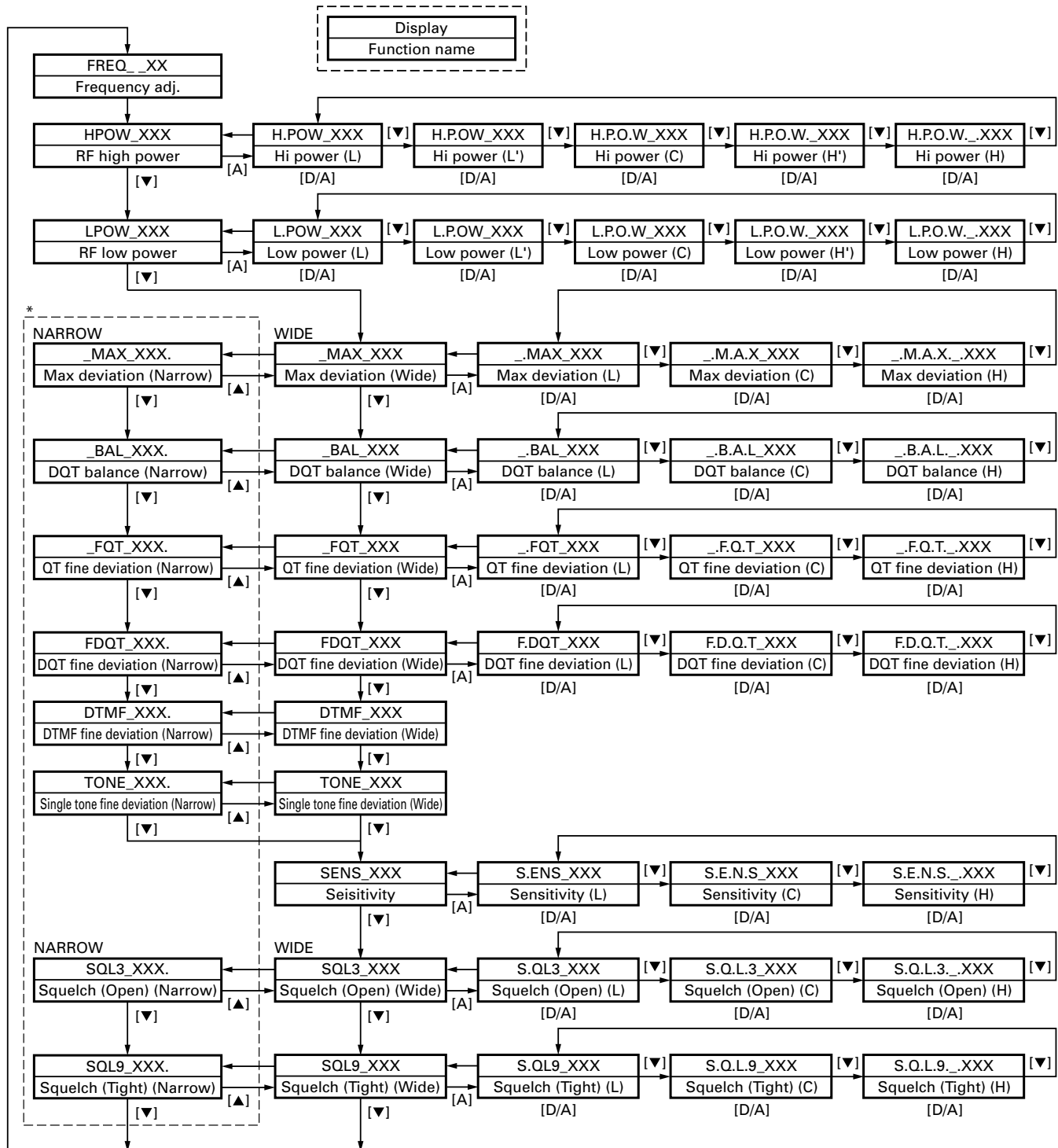

* E type is Wide 4k, NE type not used.

ADJUSTMENT

Test Equipment Required for Alignment

Test Equipment	Major Specifications	
1. Standard Signal Generator (SSG)	Frequency Range Modulation Output	136 to 174MHz Frequency modulation and external modulation -127dBm/0.1μV to greater than -7dBm/100mV
2. Power Meter	Input Impedance Operation Frequency Measurement Capability	50Ω 136 to 174MHz or more Vicinity of 100W
3. Deviation Meter	Frequency Range	136 to 174MHz
4. Digital Volt Meter (DVM)	Measuring Range Accuracy	1 to 20V DC High input impedance for minimum circuit loading
5. Oscilloscope		DC through 30MHz
6. High Sensitivity Frequency Counter	Frequency Range Frequency Stability	10Hz to 1000MHz 0.2ppm or less
7. Ammeter		20A
8. AF Volt Meter (AF VTVM)	Frequency Range Voltage Range	50Hz to 10kHz 1mV to 10V
9. Audio Generator (AG)	Frequency Range Output	20Hz to 20kHz or more 0 to 1V
10. Distortion Meter	Capability Input Level	3% or less at 1kHz 50mV to 10Vrms
11. 4Ω Dummy Load		Approx. 4Ω, 10W or more
12. Regulated Power Supply		13.2V, approx. 20A (adjustable from 9 to 20V) Useful if ammeter requipped

Tuning cable (E30-3383-05)

Adapter cable (E30-3383-05) is required for injecting an audio if PC tuning is used. See "PC Mode" section for the connection.

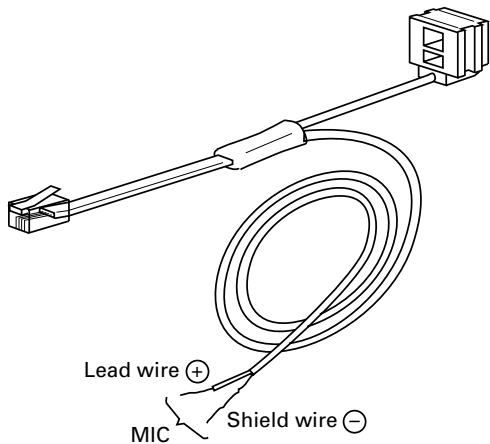

Test cable for microphone input (E30-3360-08)

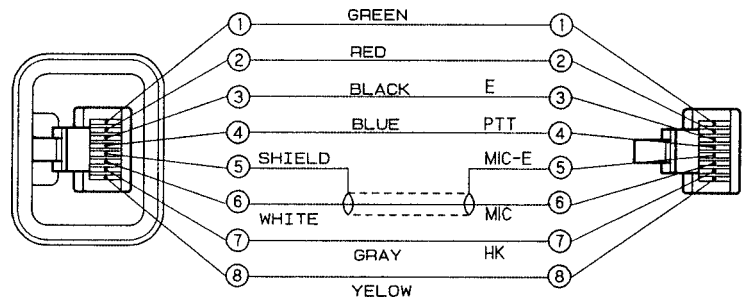

MIC connector (Front view)

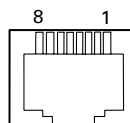

- 1 : BLC
- 2 : PSB
- 3 : E
- 4 : PTT
- 5 : ME
- 6 : MIC
- 7 : HOOK
- 8 : CM

TK-760G/(N)/762G/(N)

ADJUSTMENT

Adjustment Location

■ Switch (TK-760G)

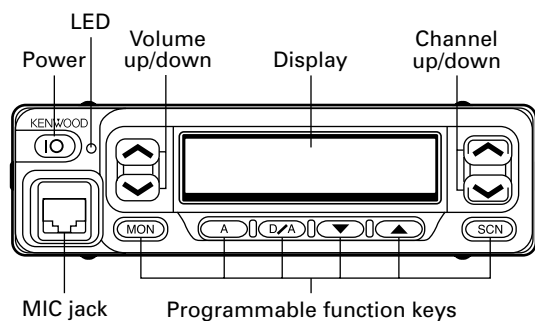

■ Note

• Flash memory

The firmware program (User mode, Test mode, Tuning mode, etc.) and the data programmed by the FPU (KPG-67D) for the flash memory, is stored in memory. When parts are changed, program the data again.

• EEPROM

The tuning data (Deviation, Squelch, etc.) for the EEPROM, is stored in memory. When parts are changed, readjust the transceiver.

■ Adjustment Point

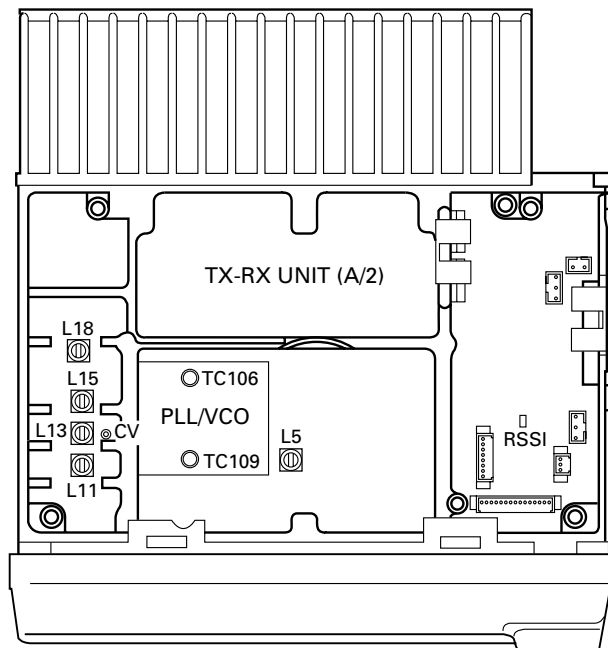

■ Repair Jig

• Chassis

Use jig (Part No. : A10-4010-02) for repairing the TK-760G/762G. The jig facilitates the voltage check when the voltage on the component side TX-RX unit is checked during repairs.

• Extension cable

Part No. : E30-3404-05

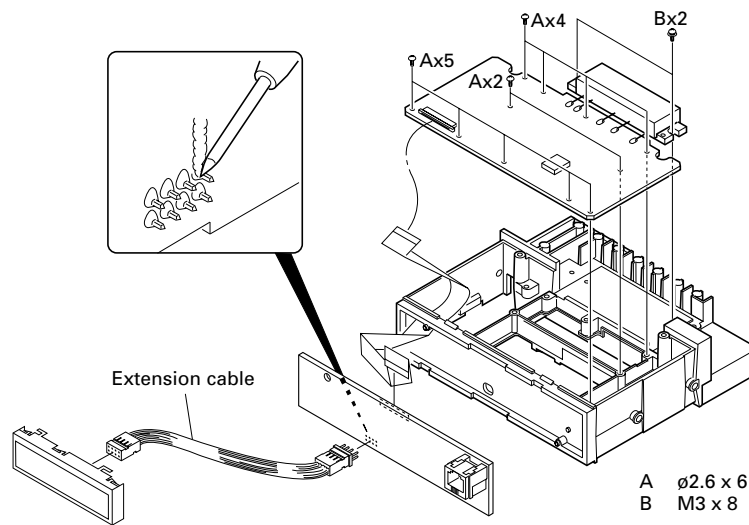

ADJUSTMENT

Common Section

Item	Condition	Measurement			Adjustment			Specifications/Remarks
		Test-equipment	Unit	Terminal	Unit	Parts	Method	
1. PLL lock voltage RX	1) Set test mode CH : CH3 - Sig1	DVM Power meter F. conter	TX-RX (A/2)	CV	PLL	TC106	7.5V	±0.1V
	TX					2) PTT : ON (Transmit)	TC109	
	RX	3) CH : CH2 - Sig1 AUX : ON (Talk-around mode)				Check	1.0V or more	
	TX	4) PTT : ON (Transmit)					0.5V or more	

Note

- To adjust TK-762G, use KPG-67D FPU, otherwise you cannot tune this transceiver from the front panel.
- TK-760G NE and TK-762G NE are "Narrow" band models. TK-760G E and TK-762G E are "Wide (Wide 5k) & Semi wide (Wide 4k)" band models. Refer to the relative adjustment value in the table.

Receiver Section

Item	Condition	Measurement			Adjustment			Specifications/Remarks
		Test-equipment	Unit	Terminal	Unit	Parts	Method	
1. Discriminator	1) Set test mode CH : CH1 - Sig1 SSG output : -53dBm/501 μ V SSG MOD : 3kHz E 1.5kHz NE AF : 1.4V/4 Ω	S G AF VTVM Oscilloscope	Rear panel	ANT ACC (EXT.SP)	TX-RX (A/2)	L5	AF output maximum.	
2. Sensitivity	1) Set test mode Select "SENS" in tuning mode. "S.E.N.S" Adjust [120] SSG freq' : 160.050MHz SSG output : -115dBm/0.4 μ V SSG MOD : 3kHz E 1.5kHz NE AF output : 0.45V/4 Ω	S G AF VTVM Distortion meter Oscilloscope AG DVM	Rear panel	ANT ACC (EXT.SP) RSSI	TX-RX (A/2)	L11 L13 L15 L18	RSSI voltage maximum.	
	2) "S.ENS" Adjust [***] SSG freq' : 146.050MHz				Front panel	CH 		
	3) "S.E.N.S._" Adjust [***] SSG freq' : 173.950MHz							

ADJUSTMENT

Item	Condition	Measurement			Adjustment			Specifications/Remarks
		Test-equipment	Unit	Terminal	Unit	Parts	Method	
3. Squelch 3 • Wide/ Narrow	1) Set test mode Select "SQL3" in tuning mode. "S.QL3" Adjust [***] SSG freq' : 146.050MHz SSG output : -125dBm/0.13μV SSG MOD : 3kHz (Wide) 1.5kHz (Narrow)	SSG AF VTVM Distortion meter Oscilloscope AG	Rear panel	ANT ACC (EXT.SP)	Front panel	CH 	Adjust to the squelch threshold point.	
	2) "S.Q.L.3" Adjust [***] SSG freq' : 160.050MHz							
	3) "S.Q.L.3._." Adjust [***] SSG freq' : 173.950MHz							
	• Semi wide							
4. Squelch 9 • Wide/ Narrow	1) Set test mode Select "SQL9" in tuning mode. "S.QL9" Adjust [***] SSG freq' : 146.050MHz SSG output : -115dBm/0.4μV SSG MOD : 3kHz (Wide) 1.5kHz (Narrow)							
	2) "S.Q.L.9" Adjust [***] SSG freq' : 160.050MHz							
	3) "S.Q.L.9._." Adjust [***] SSG freq' : 173.950MHz							
	• Semi wide							
5. Squelch check	1) Set test mode CH : CH1 - Sig1~CH3 - Sig1 SSG output : -117dBm/0.31μV					Check	Squelch must be opened. (Wide/Semi wide/Narrow)	
	2) SSG output : OFF						Squelch must be closed. (Wide/Semi wide/Narrow)	

ADJUSTMENT

Item	Condition	Measurement			Adjustment			Specifications/Remarks
		Test-equipment	Unit	Terminal	Unit	Parts	Method	
6. QT check	1) Set test mode CH : CH1 - Sig4 SSG MOD INT : 3kHz (Wide), 1.5kHz (Narrow) EXT : 151.4Hz SSG system MOD DEV : ±3.75kHz (Wide), ±1.85kHz (Narrow) SSG output : 10dB SINAD level	SSG AF VTVM Distortion meter Oscilloscope AG	Rear panel	ANT ACC (EXT.SP)				
	2) CH : CH1 - Sig3 CH1 - Sig5 CH1 - Sig6						Check	Spelch must be opened.



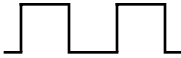

Transmitter Section

Item	Condition	Measurement			Adjustment			Specifications/Remarks
		Test-equipment	Unit	Terminal	Unit	Parts	Method	
1. Frequency	1) Set test mode Select "FREQ" in tuning mode. PTT : ON Adjust [_**]	Power meter F. counter	Rear panel	ANT	Front panel	CH 	Check	160.100MHz±50Hz
2. Power output	1) Maximum power Set test mode Select "HPOW" in tuning mode. "H.POW" Adjust [256] PTT : ON						Check	More than 26.0W
3. High power	1) Set test mode Select "HPOW" in tuning mode. "H.POW" PTT : ON Adjust [***]						25.0W	±1.0W
	2) "H.P.O.W" PTT : ON Adjust [***]							
	3) "H.P.O.W" PTT : ON Adjust [***]							
	4) "H.P.O.W." PTT : ON Adjust [***]							
	5) "H.P.O.W._." PTT : ON Adjust [***]							
4. Low power	1) Set test mode Select "LPOW" in tuning mode. "L.POW" PTT : ON Adjust [***]	Power meter					6.0W	±0.5W
	2) "L.P.O.W" PTT : ON Adjust [***]							

ADJUSTMENT

Item	Condition	Measurement			Adjustment			Specifications/Remarks
		Test-equipment	Unit	Terminal	Unit	Parts	Method	
	3) "L.P.O.W" PTT : ON Adjust [***] 4) "L.P.O.W." PTT : ON Adjust [***] 5) "L.P.O.W._." PTT : ON Adjust [***]	Power meter	Rear panel	ANT	Front panel	CH \sim	6.0W	$\pm 0.5W$
5. Power check	1) Set test mode CH : CH1 - Sig1 CH2 - Sig1 CH3 - Sig1 PTT : ON	Power meter Ammeter	Rear panel	ANT DC IN			Check	25W \pm 1W, 8A or less
6. Modulation balanced • Wide/ Narrow	1) Set test mode MIC input : OFF Select "BAL" in tuning mode. "_.BAL" Deviation meter filter LPF : 3kHz, HPF : OFF De-emphasis : OFF PTT : ON Adjust [***] 2) "_.B.A.L" PTT : ON Adjust [***] 3) "_.B.A.L._." PTT : ON Adjust [***]	Power meter Deviation meter Oscilloscope AF VTVM AG	Rear panel Front panel	ANT MIC	Front panel	CH \sim	Make the de-modulation waveform neat.	(Wide/Semi wide/Narrow) 
• Semi wide	4) "_.BAL***." PTT : ON Adjust [***]							
7. Maximum deviation • Wide/ Narrow	1) Set test mode Connect AG to the MIC terminal. Select "MAX" in tuning mode. "_.MAX" AG : 1kHz/50mV Deviation meter filter LPF : 15kHz, HPF : OFF De-emphasis : OFF PTT : ON Adjust [***] 2) "_.M.A.X" PTT : ON Adjust [***] 3) "_.M.A.X._." PTT : ON Adjust [***]						3.95kHz (Wide) 1.95kHz (Narrow) (According to the larger +, -)	$\pm 50Hz$
• Semi wide	4) "_.MAX***." PTT : ON Adjust [***]						3.3kHz (According to the larger +, -)	

ADJUSTMENT

Item	Condition	Measurement			Adjustment			Specifications/Remarks
		Test-equipment	Unit	Terminal	Unit	Parts	Method	
8. MIC sensitivity check	1) Set test mode CH : CH1 - Sig1 AG : 1kHz/5mV PTT : ON	Power meter Deviation meter Oscilloscope	Rear panel	ANT			Check	$\pm 2.4\text{kHz} \sim \pm 3.4\text{kHz}$ (Wide) $\pm 1.2\text{kHz} \sim \pm 1.7\text{kHz}$ (Narrow)
9. QT deviation • Wide/ Narrow	1) Set test mode Select "FQT" in tuning mode. "_FQT" Deviation meter filter LPF : 3kHz, HPF : OFF PTT : ON Adjust [***]	AF VTVM AG	Front panel	MIC	Front panel	CH 	0.75kHz (Wide) 0.35kHz (Narrow)	$\pm 50\text{Hz}$
	2) "_F.Q.T." PTT : ON Adjust [***]							
	3) "_F.Q.T._." PTT : ON Adjust [***]							
	• Semi wide 4) "_FQT***." PTT : ON Adjust [***]						0.60kHz	
10. DQT deviation • Wide/ Narrow	1) Set test mode Select "FDQT" in tuning mode. "F.DQT" Deviation meter filter LPF : 3kHz, HPF : OFF PTT : ON Adjust [***]				Front panel	CH 	0.75kHz (Wide) 0.35kHz (Narrow)	$\pm 50\text{Hz}$
	2) "F.D.Q.T." PTT : ON Adjust [***]							
	3) "F.D.Q.T._." PTT : ON Adjust [***]							
	• Semi wide 4) "FDQT***." PTT : ON Adjust [***]						0.60kHz	
11. DTMF deviation • Wide/ Narrow	1) Set test mode Select "DTMF" in tuning mode. Deviation meter filter LPF : 15kHz, HPF : OFF PTT : ON Adjust [***]				Front panel	CH 	3.0kHz (Wide) 1.5kHz (Narrow)	$\pm 0.1\text{kHz}$ (Wide) $\pm 0.05\text{kHz}$ (Narrow)
	• Semi wide 2) "DTMF***." PTT : ON Adjust [***]						2.4kHz	$\pm 0.1\text{kHz}$
12. TONE deviation • Wide/ Narrow	1) Set test mode Select "TONE" in tuning mode. Deviation meter filter LPF : 15kHz, HPF : OFF PTT : ON Adjust [***]				Front panel	CH 	3.0kHz (Wide) 1.5kHz (Narrow)	$\pm 0.1\text{kHz}$ (Wide) $\pm 0.05\text{kHz}$ (Narrow)
	• Semi wide 2) "TONE***." PTT : ON Adjust [***]						2.4kHz	$\pm 0.05\text{kHz}$

TK-760G(N)/762G/(N) PC BOARD VIEWS

DISPLAY UNIT (X54-3270-10) : TK-760G
Component side view

DISPLAY UNIT (X54-3270-10) : TK-760G
Foil side view

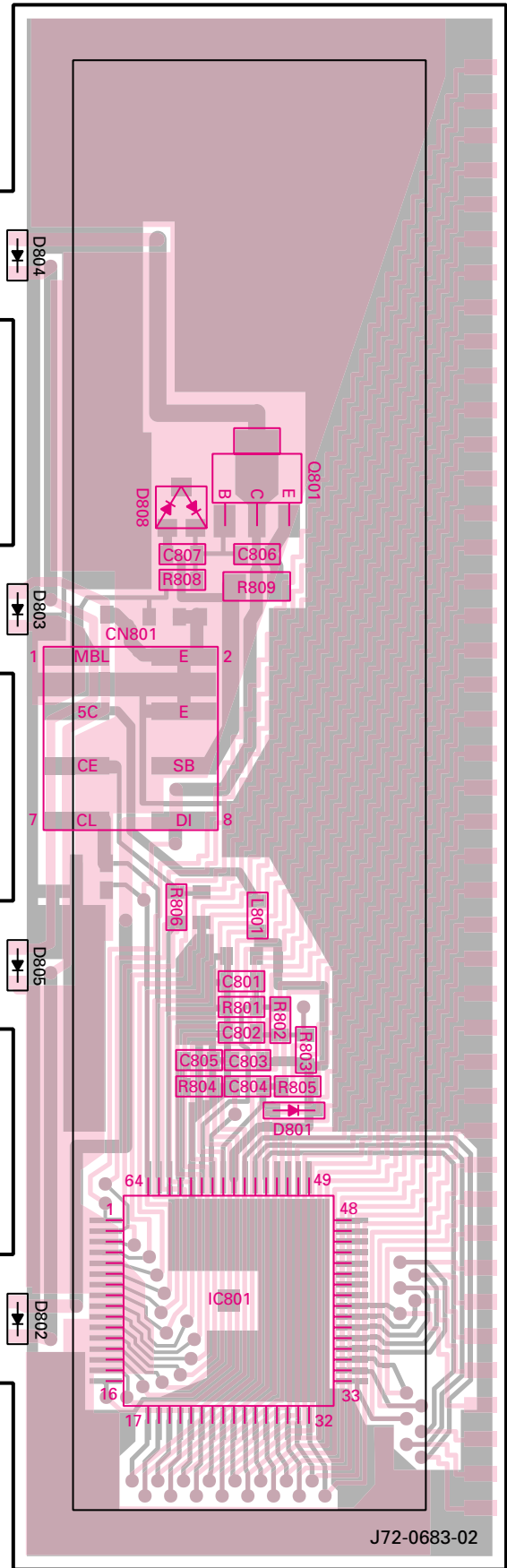
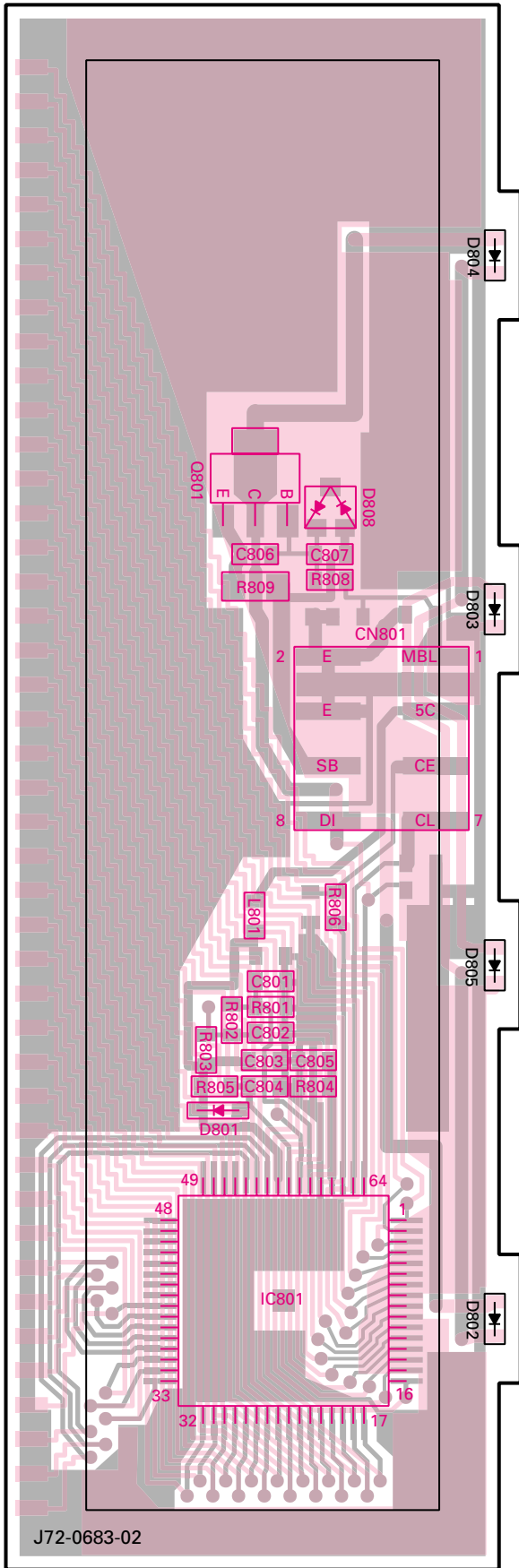

Component side Foil side

DISPLAY UNIT (X54-3280-10) : TK-762G
Component side view

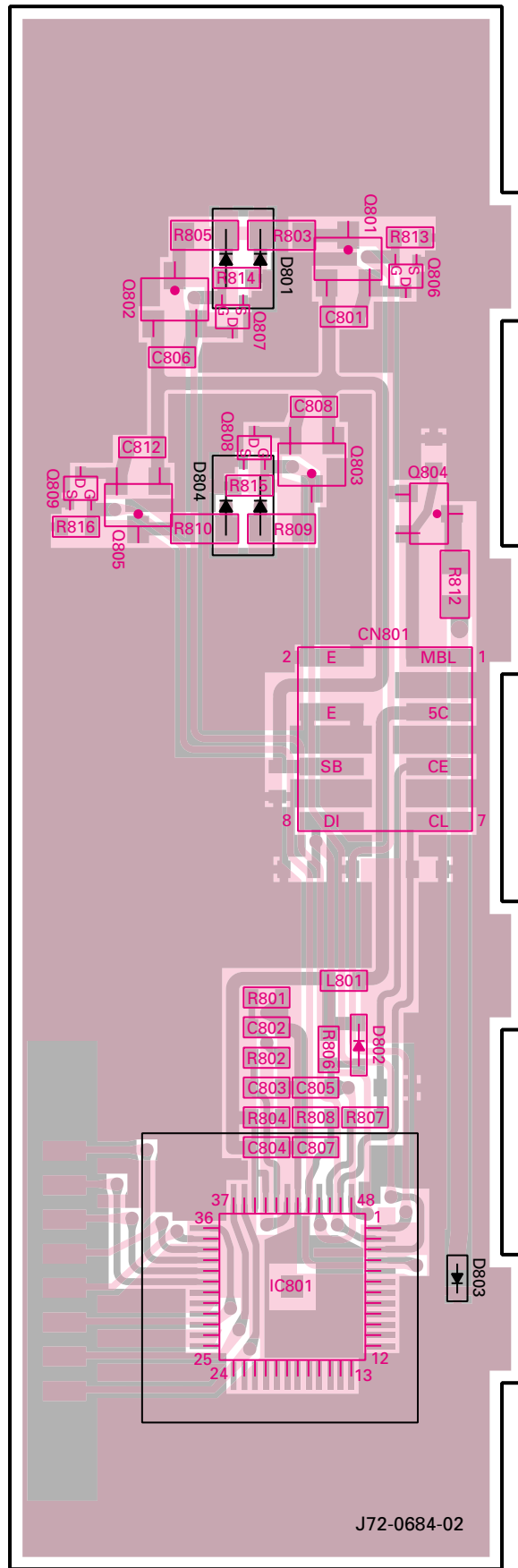

DISPLAY UNIT (X54-3280-10) : TK-762G
Foil side view

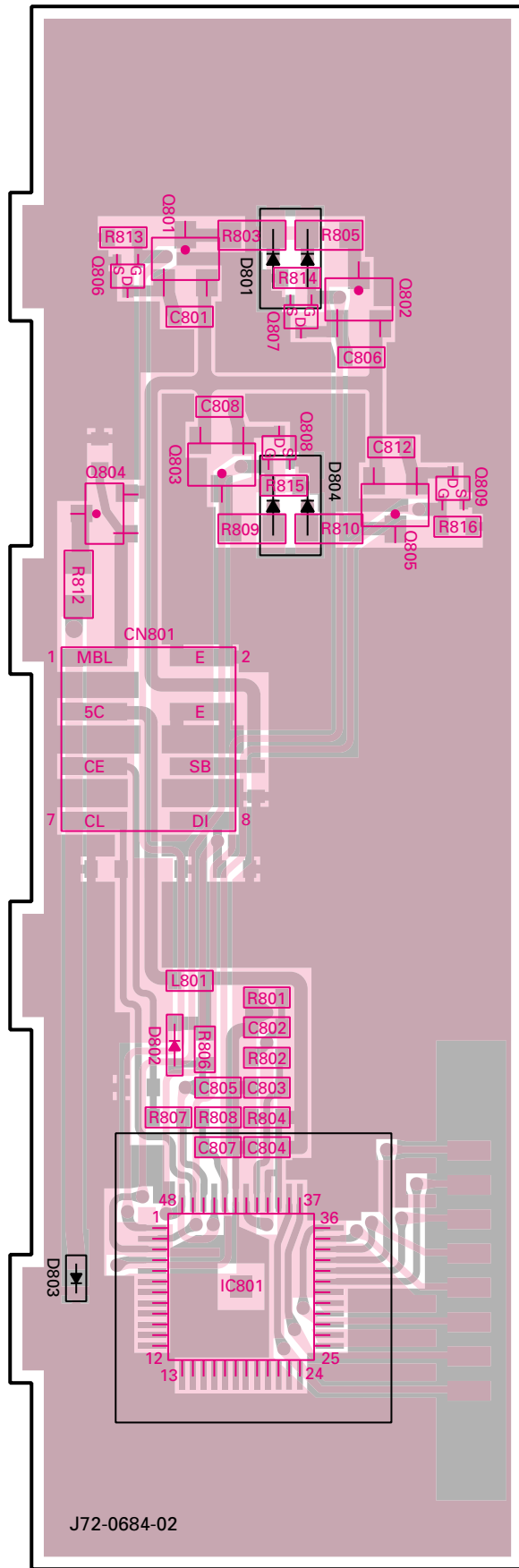

Component side Foil side

PC BOARD VIEWS TK-760/G(N)/762G/(N)

PLL/VCO (X58-4670-10) Component side view

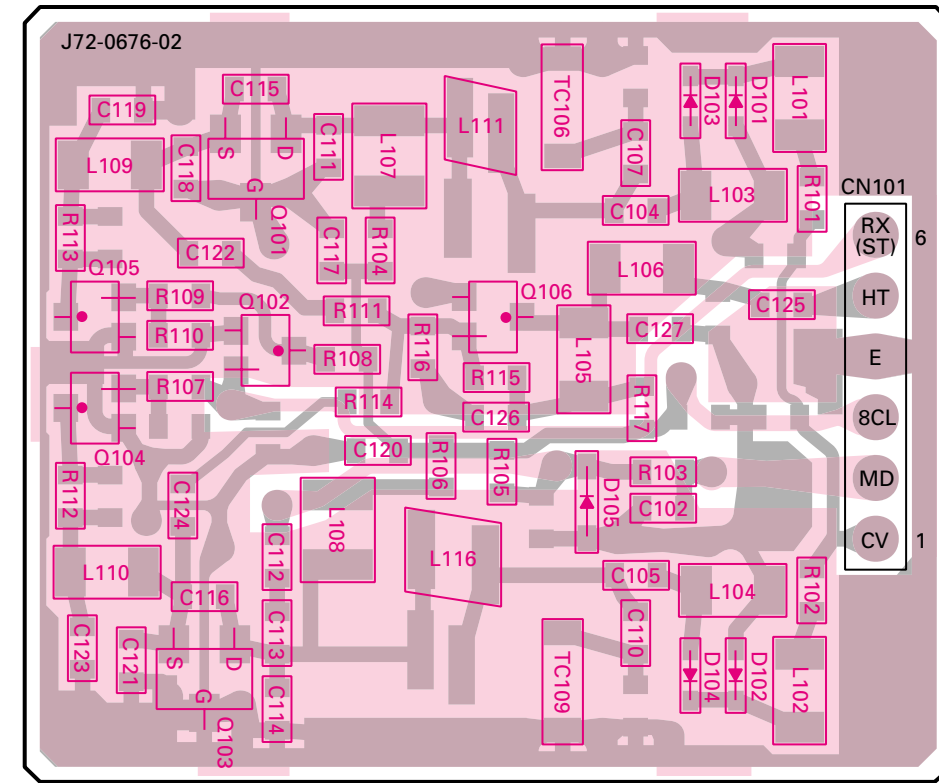

PLL/VCO (X58-4670-10) Foil side view

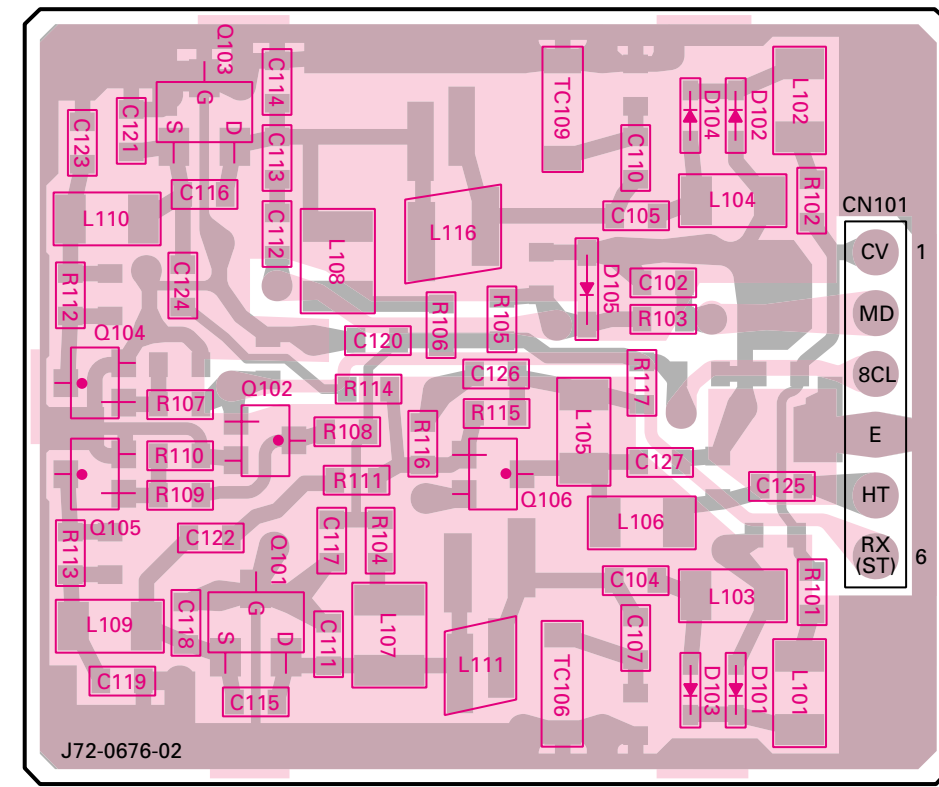

Component side
Foil side

Ref. No.	Address	Ref. No.	Address	Ref. No.	Address	Ref. No.	Address	Ref. No.	Address	Ref. No.	Address	Ref. No.	Address
IC1	11E	Q5	11B	Q18	13N	Q27	9Q	D4	13C	D20	8D	D31	8Q
IC2	9J	Q6	11B	Q19	7C	Q28	7I	D5	13D	D21	7C	D35	7Q
IC8	9N	Q7	11K	Q20	8C	Q29	7G	D11	12G	D22	7J	D36	6R
IC9	9G	Q10	13G	Q21	7C	Q31	6H	D14	10H	D23	10Q	D39	8L
IC10	8E	Q13	13K	Q22	7L	Q33	7N	D15	10B	D24	8D		
IC14	9D	Q14	10N	Q23	7E	Q36	9K	D16	11N	D27	8D		
IC15	7O	Q15	13O	Q24	8B	D1	13D	D17	7L	D28	10Q		
IC400	2K	Q16	13M	Q25	6J	D2	12B	D18	12Q	D29	5D		
Q1	11B	Q17	9B	Q26	8C	D3	13C	D19	8B	D30	8Q		

TX-RX UNIT (X57-595X-XX) (A/2) Foil side view
 2-71 : TK-760G(N) 2-72 : TK-762G(N) 2-73 : TK-762G 2-74 : TK-760G

PC BOARD VIEW TK-760G/(N)/762G/(N)

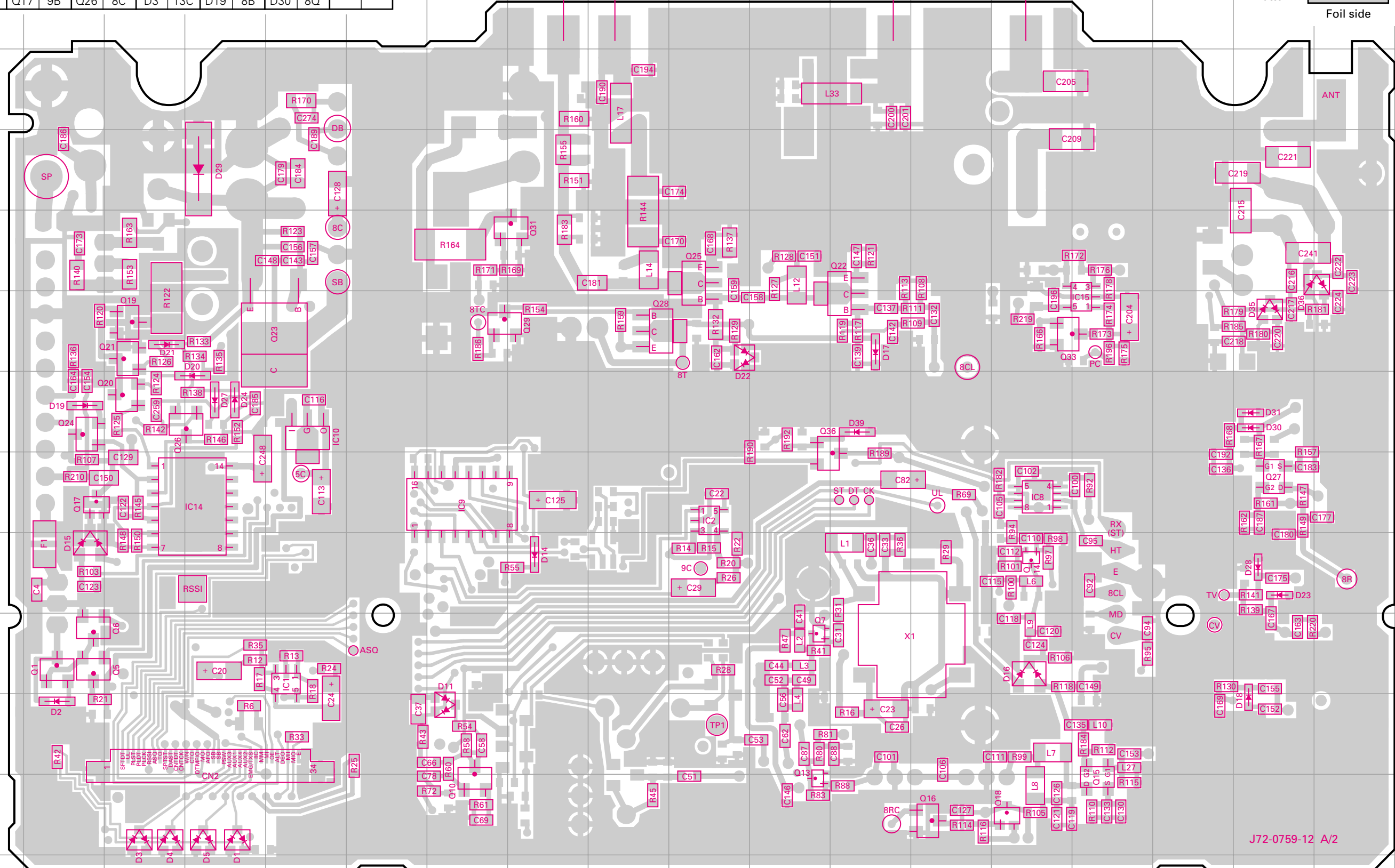
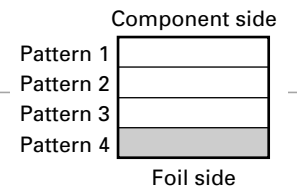
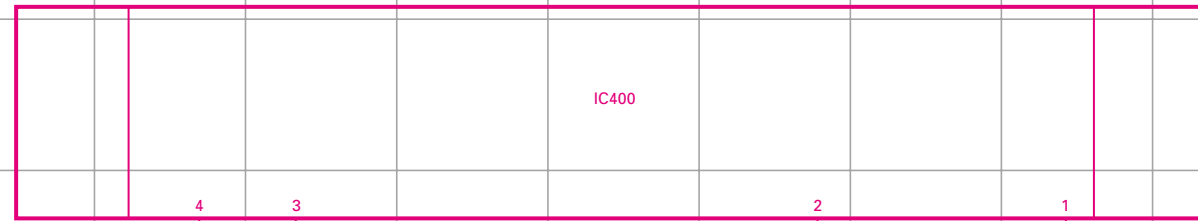

J72-0759-12 A/2

TK-760G/(N)/762G/(N) PC BOARD VIEW

TX-RX UNIT (X57-595X-XX) (A/2) Component side view + Foil side

2-71 : TK-760G(N) 2-72 : TK-762G(N) 2-73 : TK-762G 2-74 : TK-760G

Ref. No.	Address	Ref. No.	Address	Ref. No.	Address	Ref. No.	Address	Ref. No.	Address	Ref. No.	Address	Ref. No.	Address	Ref. No.	Address
IC1	11O	IC12	6O	Q9	10F	Q20	8Q	Q32	4O	D11	12M	D24	8P	D39	8H
IC2	9J	IC13	8R	Q10	13M	Q21	7Q	Q33	7F	D14	10L	D25	5O	D40	11M
IC3	10H	IC14	9P	Q11	11G	Q22	7H	Q36	9I	D15	10R	D27	8P	D41	11G
IC4	12M	IC15	7E	Q12	11G	Q23	7O	Q37	11L	D16	11F	D28	10C		
IC5	12I	IC400	2I	Q13	13I	Q24	8R	Q38	12R	D17	7H	D29	5P		
IC6	10M	Q1	11R	Q14	10F	Q25	6J	D1	13P	D18	12C	D30	8C		
IC7	9L	Q2	12R	Q15	13E	Q26	8Q	D2	12R	D19	8R	D31	8C		
IC8	9F	Q5	11R	Q16	13G	Q27	9C	D3	13Q	D20	8P	D33	6C		
IC9	9M	Q6	11R	Q17	9R	Q28	7K	D4	13Q	D21	7Q	D34	5E		
IC10	8O	Q7	11I	Q18	13F	Q29	7M	D5	13P	D22	7J	D35	7C		
IC11	10J	Q8	7G	Q19	7Q	Q31	6L	D9	9G	D23	10C	D36	6B		

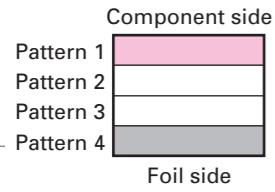

● Connect 1 and 4

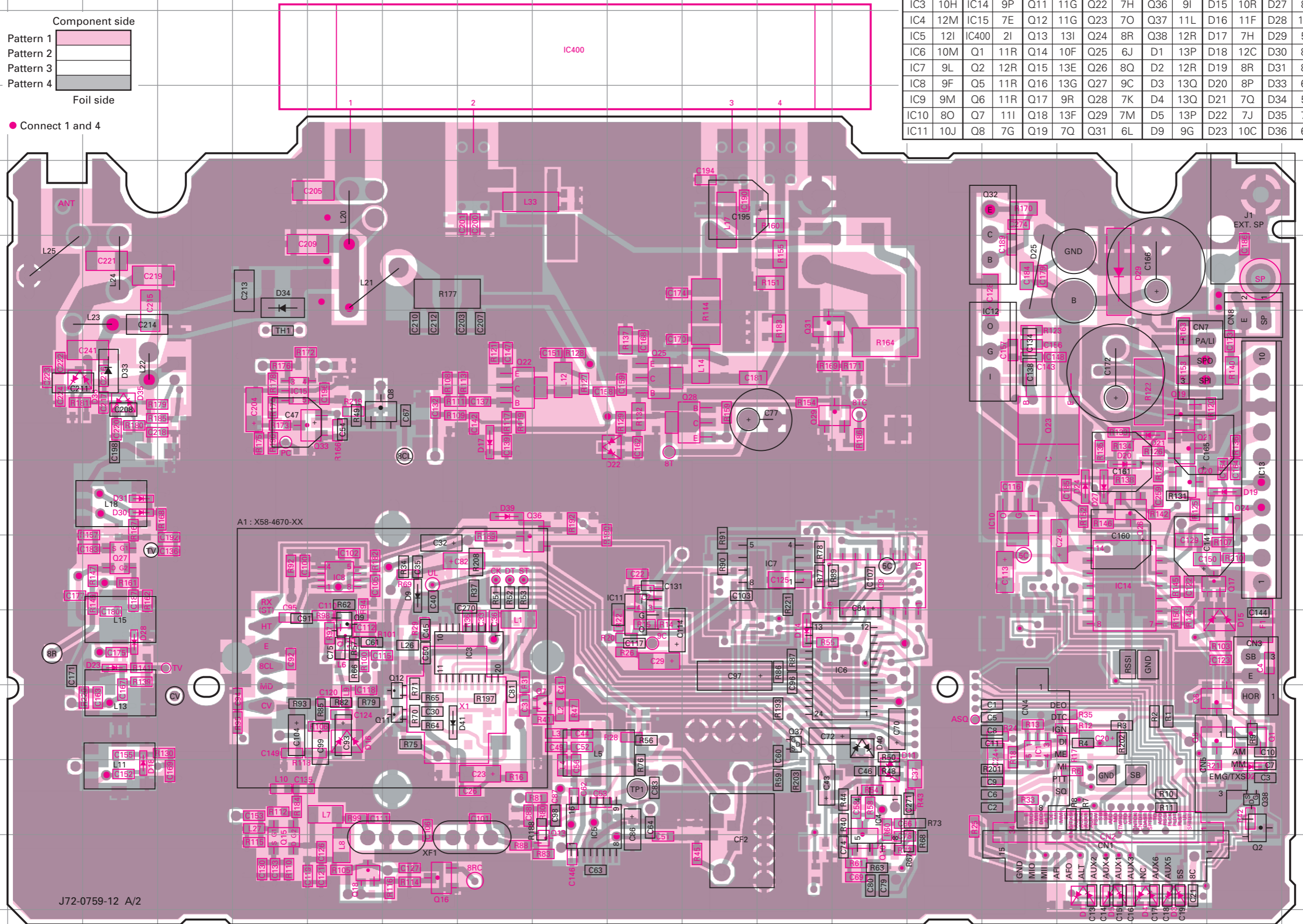

J72-0759-12 A/2

TX-RX UNIT (X57-595X-XX) (B/2) Component side view
 2-71 : TK-760G(N) 2-72 : TK-762G(N) 2-73 : TK-762G 2-74 : TK-760G

PC BOARD VIEWS TK-760G/(N)/762G/(N)

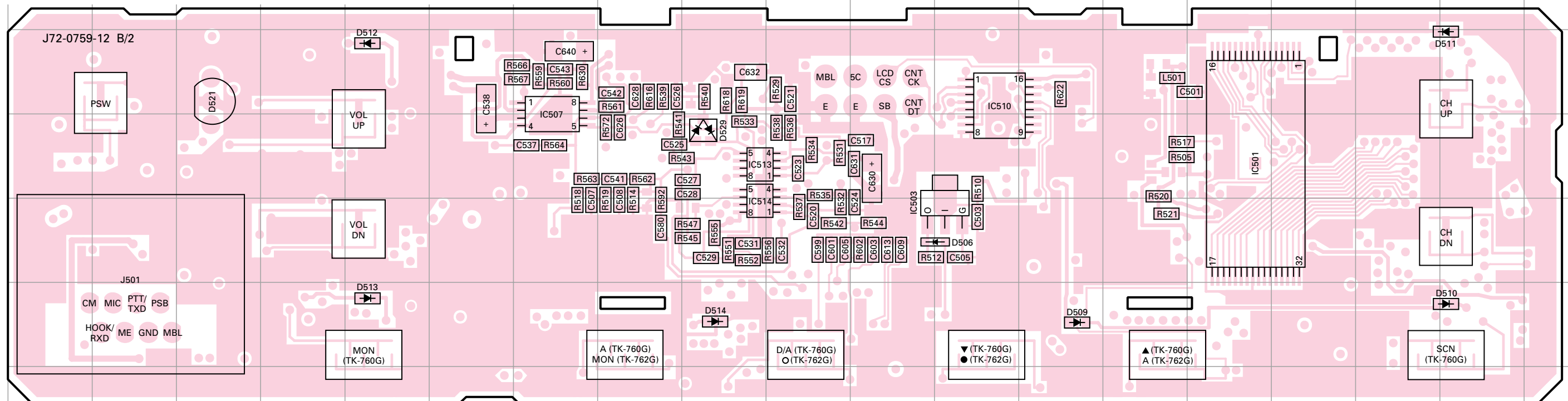

Ref. No.	Address	Ref. No.	Address	Ref. No.	Address	Ref. No.	Address	Ref. No.	Address
IC501	3O	IC510	2L	D506	4L	D511	2R	D514	5I
IC503	4L	IC513	3I	D509	5M	D512	2E	D521	2C
IC507	2G	IC514	4I	D510	5R	D513	5E	D529	3I

Component side

Pattern 1
 Pattern 2
 Pattern 3
 Pattern 4

Foil side

TX-RX UNIT (X57-595X-XX) (B/2) Foil side view
 2-71 : TK-760G(N) 2-72 : TK-762G(N) 2-73 : TK-762G 2-74 : TK-760G

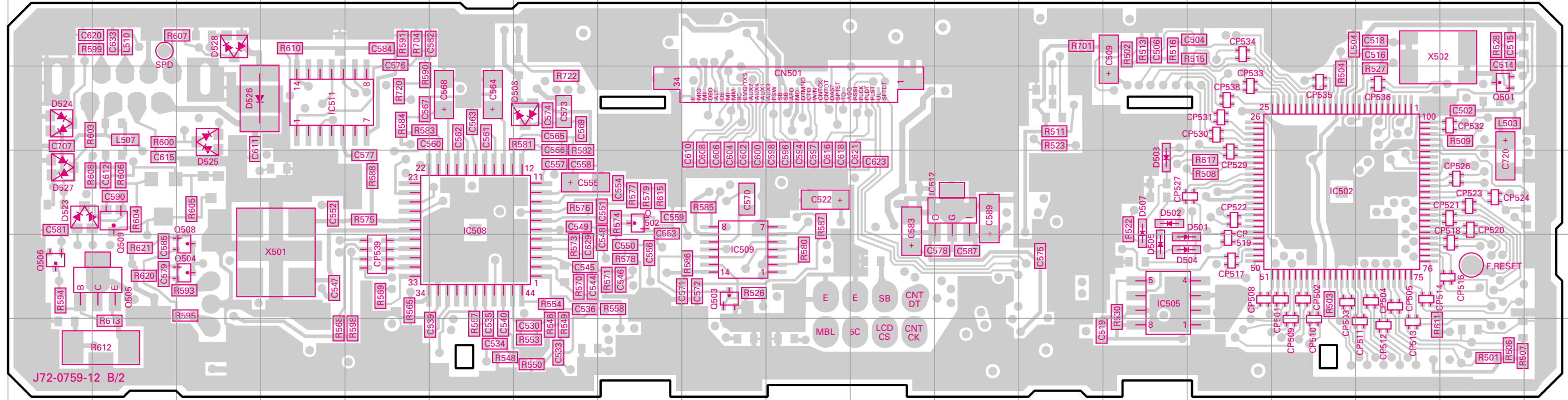

Ref. No.	Address	Ref. No.	Address	Ref. No.	Address	Ref. No.	Address	Ref. No.	Address	Ref. No.	Address	Ref. No.	Address	Ref. No.	Address
IC502	10P	IC509	11I	Q501	9R	Q504	11C	Q508	11C	D502	10N	D505	11N	D523	10A
IC505	11N	IC511	9D	Q502	10H	Q505	11B	Q509	10B	D503	10N	D507	10N	D524	9A
IC508	10F	IC512	10L	Q503	11I	Q506	11A	D501	11N	D504	11N	D508	9G	D525	9C

Component side

Pattern 1
 Pattern 2
 Pattern 3
 Pattern 4

Foil side

TK-760G/(N)/762G/(N) PC BOARD VIEW

TX-RX UNIT (X57-595X-XX) (B/2) Component side view + Foil side

2-71 : TK-760G(N) 2-72 : TK-762G(N) 2-73 : TK-762G 2-74 : TK-760G

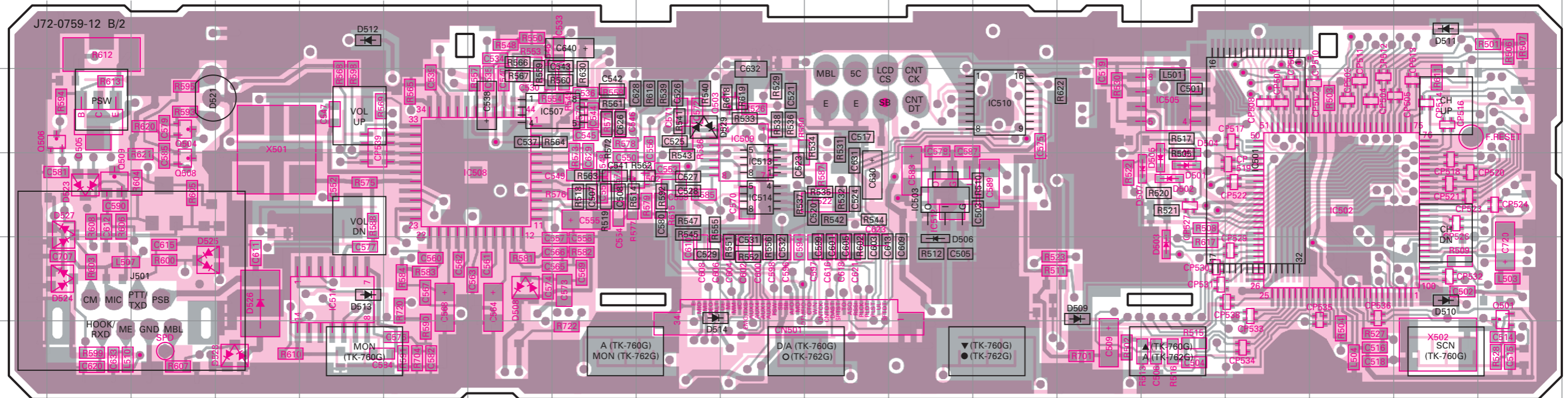

Ref. No.	Address	Ref. No.	Address	Ref. No.	Address	Ref. No.	Address	Ref. No.	Address	Ref. No.	Address
IC501	4P	IC510	3M	Q503	3J	D502	4O	D509	5N	D523	4B
IC502	4Q	IC511	5E	Q504	3C	D503	5O	D510	5R	D524	5B
IC503	4L	IC512	4L	Q505	3B	D504	4O	D511	2R	D525	5C
IC505	3O	IC513	4J	Q506	3B	D505	4O	D512	2E	D526	5D
IC507	3H	IC514	4J	Q508	4C	D506	5L	D513	5E	D527	4B
IC508	4G	Q501	5S	Q509	4B	D507	4O	D514	5I	D528	6D
IC509	3J	Q502	4I	D501	4O	D508	5G	D521	3C	D529	3I

Component side

Pattern 1

Pattern 2

Pattern 3

Pattern 4

Foil side

● Connect 1 and 4

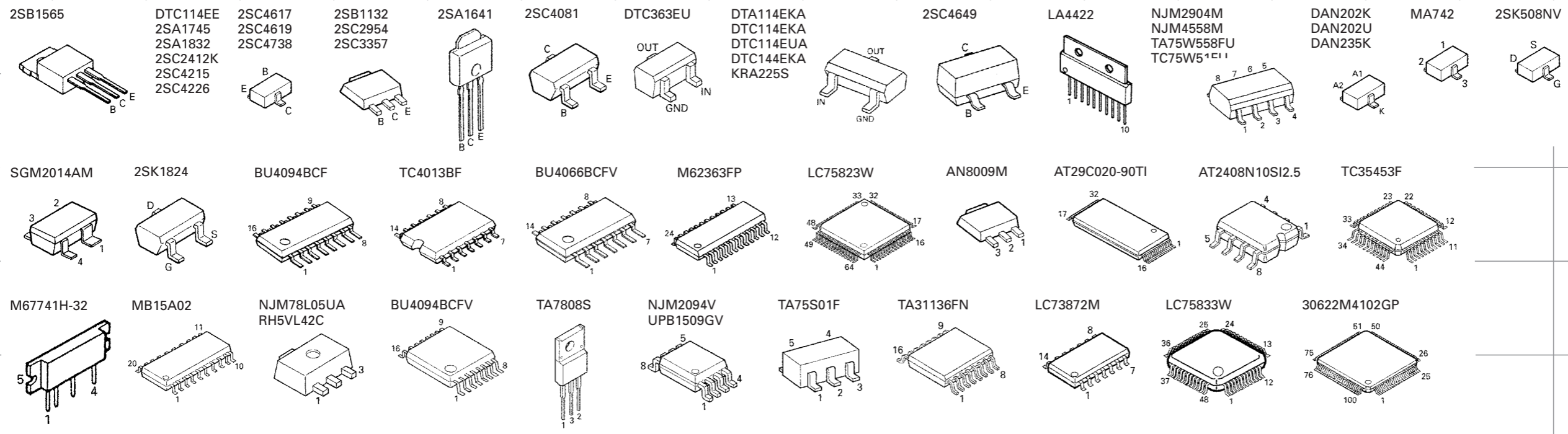

Note : Components marked with a dot (·) are parts of pattern 1.

SCHEMATIC DIAGRAM TK-760G/(N)

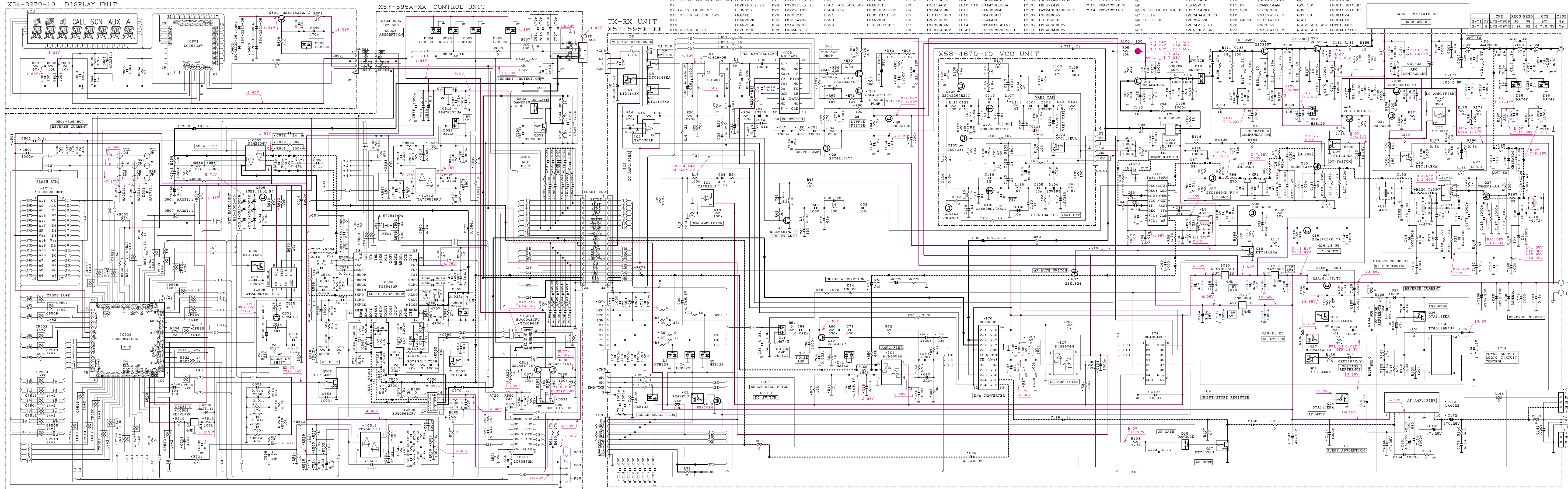

TK-762G/(N) SCHEMATIC DIAGRAM

Note : Components marked with a dot (·) are parts of pattern 1.

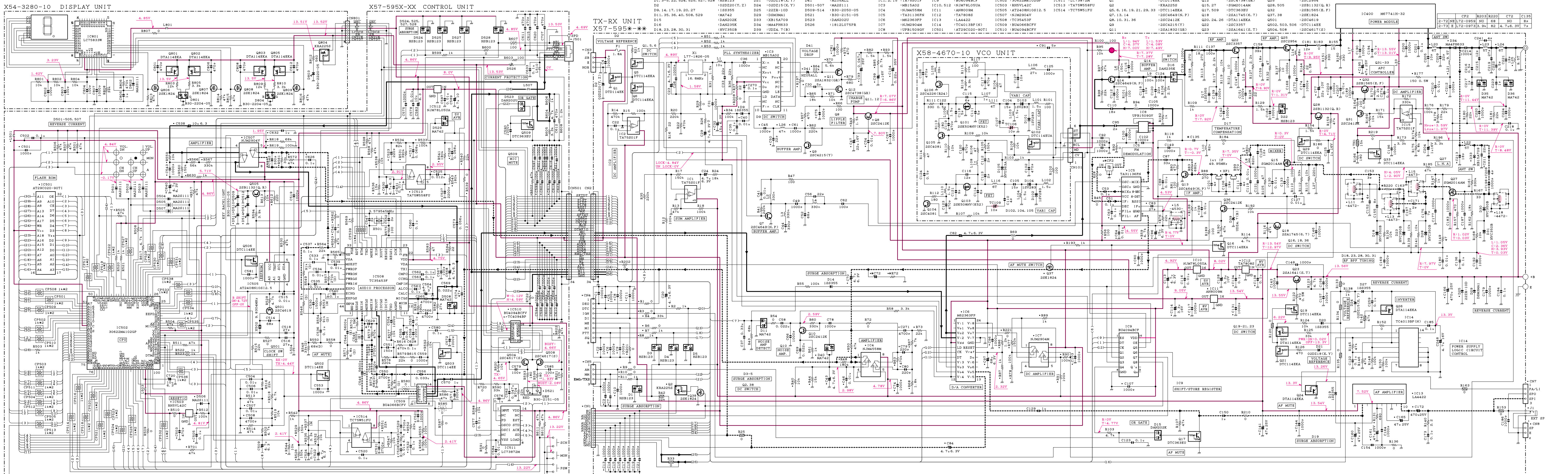

BLOCK DIAGRAM

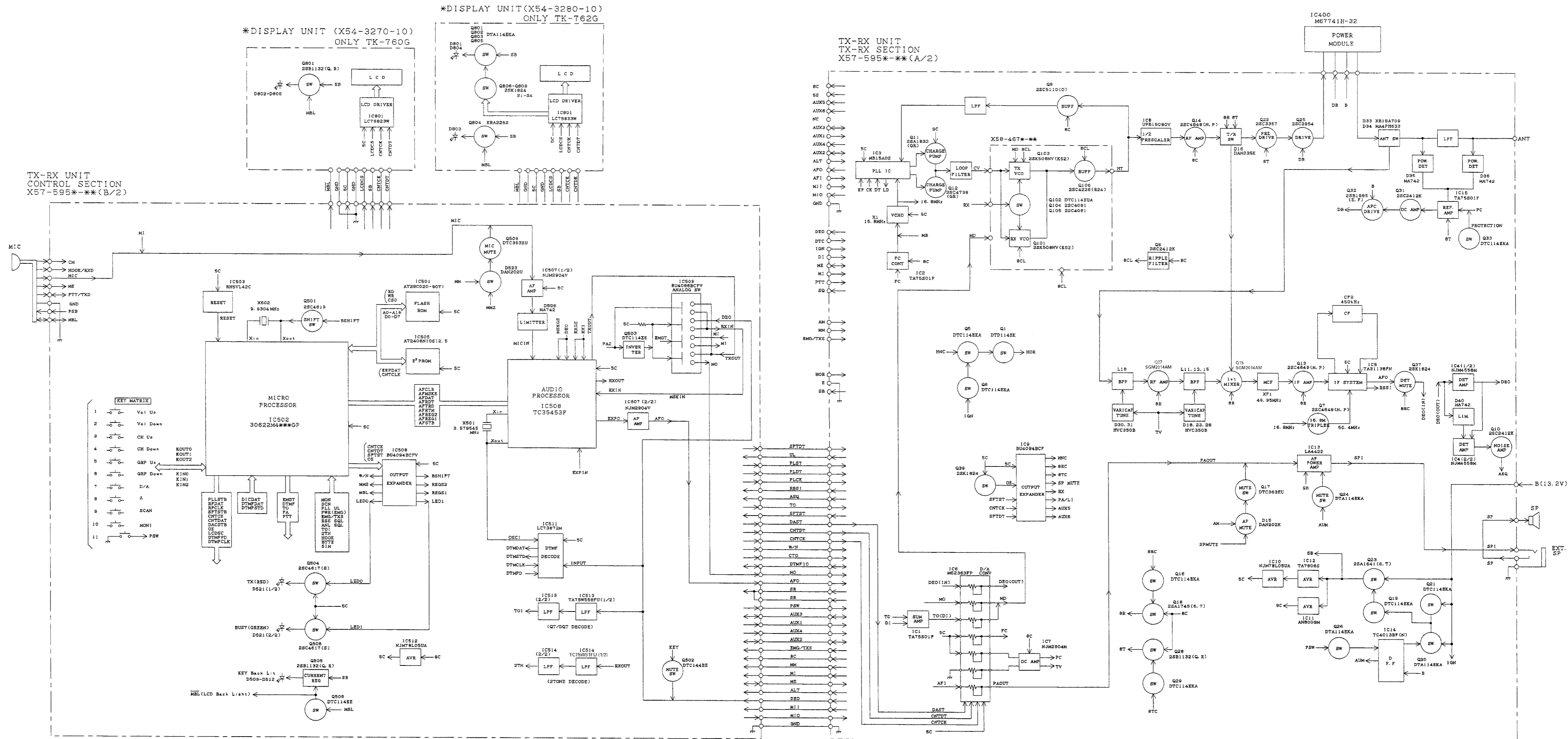

TK-760G/(N)/762G/(N) TK-760G/(N)/762G/(N)

LEVEL DIAGRAM

Receiver Section

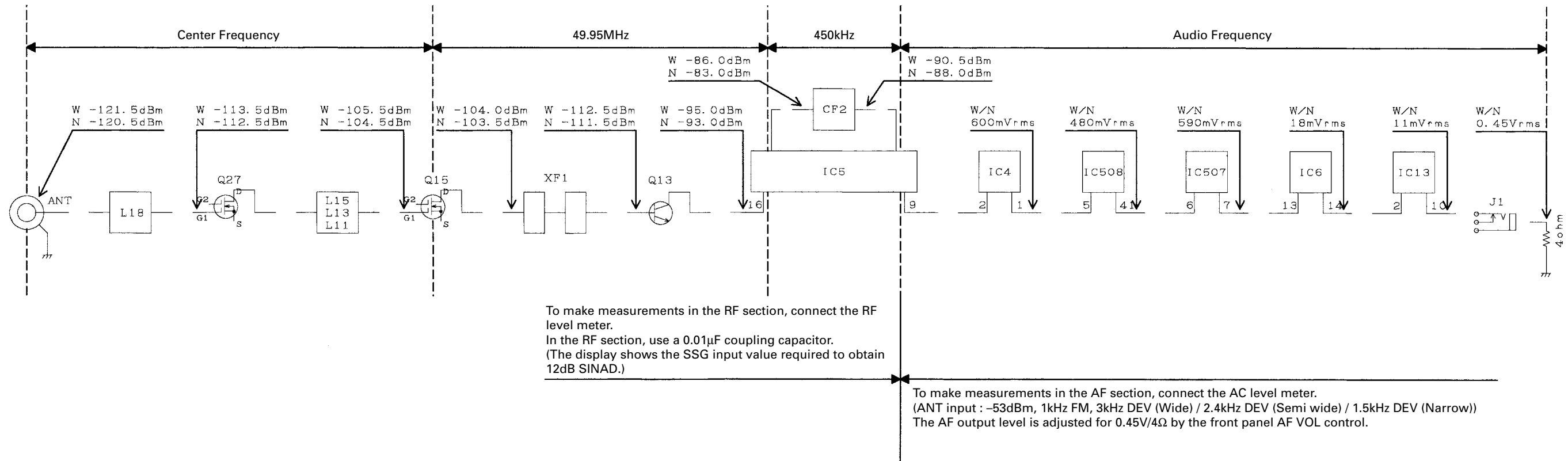

Transmitter Section

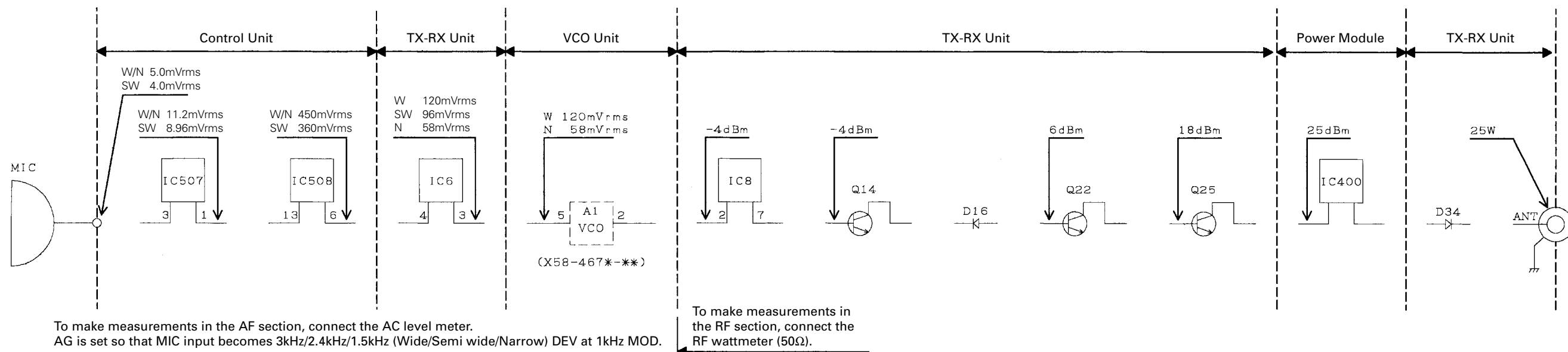

TERMINAL FUNCTION

CN1 (TX-RX Unit)

Pin No.	Name	Function
1	8C	DC 8V output.
2	5S	DC 5V output.
3	AUX5	
4	AUX6	
5	NC	Non-connection
6	AUX3	SQ : Squelch detect output. *1
7	AUX1	PTT : External PTT input. *1
8	AUX4	
9	AUX2	DTC : Data channel control/External hook input. CHDATA : Channel control serial data input.
10	ALT	Alert tone input.
11	AFO	Receiver audio signal output.
12	AFI	Receiver audio signal input.
13	MII	Transmit audio signal input.
14	MIO	Transmit audio signal output.
15	GND	Ground

CN2 (TX-RX Unit) ↔ CN501 (Control Unit)

Pin No.	Name	Function
1	SFTDT	Serial data for IC9 (Shift register).
2	UL	Lock detect.
3	PLST	Strobe signal for IC3 (PLL IC).
4	PLDT	Serial data for IC3 (PLL IC).
5	PLCK	Clock pulse for IC3 (PLL IC).
6	RSSI	Receive signal strength indicator.
7	ASQ	Analog squelch.
8	TO	Transmit sub-tone signal output.
9	SFTST	Strobe signal for IC9 (Shift register).
10	DAST	Strobe signal for IC6 (Shift register).
11	CNTDT	Control serial data for IC6.
12	CNTCK	Control clock pulse for IC6.
13	W/N	Not used.
14	CTO	Received sub-tone signal.
15	DTMFIO	DTMF signal.
16	MO	Modulation signal.
17	AFO	Receiver audio signal.
18	SB	Switched B.
19	SB	Switched B.
20	PSW	Power switch.
21	AUX3	Optional unit control signal.
22	AUX1	Optional unit control signal.
23	AUX4	Optional unit control signal.
24	AUX2	Optional unit control signal.
25	EMG	Foot switch input signal.
26	8C	DC 8V.
27	MM	MIC mute.
28	MI	External MIC input signal.
29	OE	Output enable for IC9.
30	ALT	Alert tone signal.
31	DEO	Receiver detector output.
32	MII	Transmit audio signal input.
33	MIO	Transmit audio signal output.
34	GND	Ground.

*1 : MDT mode

*2 : Emergency mode

CN3 (TX-RX Unit)

Pin No.	Name	Function
1	HOR	Horn alert/call output.
2	E	Ground.
3	SB	Switched B+, DC 13.2V output, Maximum 1A.

CN4 (TX-RX Unit)

Pin No.	Name	Function
1	DEO	Receiver detector output. Level : 0.5Vrms (Atandard modulation)
2	DTC	Data channel control/External hook input.
3	IGN	Ignition sense input.
4	DI	Data modulation input.
5	ME	External microphone ground.
6	MI	EXternal microphone input.
7	PTT	External PTT input, active low.
8	SQ	Squelch detect output.

CN5 (TX-RX Unit)

Pin No.	Name	Function
1	AM	Speaker mute input, active high.
2	MM	MIC mute input, active high
3	EMG	EMG : Foot switch input, active low. *2

CN7 (TX-RX Unit)

Pin No.	Name	Function
1	PA/LI	Relay for PA function KAP-1 control. "H" : PA/LI on, "L" : PA/LI off
2	SPO	Audio signal output to KAP-1
3	SPI	Audio signal inpt from KAP-1

CN8 (TX-RX Unit)

Pin No.	Name	Function
1	SP	Audio signal output to internal/external speaker.
2	E	Ground

J501 (Control Unit)

Pin No.	Name	Function
1	MBL	MIC backlight control.
2	PSB	13.2V.
3	GND	Ground.
4	PTT/TXD	PTT.
5	ME	MIC ground.
6	MIC	MIC signal input.
7	HOOK/RXD	Hook detection
8	CM	MIC data detection.

CN101 (PLL/VCO) ↔ TX-RX Unit

Pin No.	Name	Function
1	CV	Control voltage input.
2	MD	Modulation input.
3	8CL	8V input.
4	E	Ground.
5	HT	Signal output.
6	RX (ST)	Switched transmit input. H : Transmit

SPECIFICATIONS**GENERAL**

Frequency Range	146 to 174MHz		
Number of Channels	TK-762G : Maximum 8 channels	TK-760G : Maximum 128 channels	
Number of Groups	TK-760G : Maximum 128 groups		
Channel Spacing			
TK-760G/TK-762G	Wide : 25kHz	Semi wide : 20kHz	
TK-760G(N)/762G(N)	Narrow : 12.5kHz		
PLL Channel Stepping	5kHz, 6.25kHz		
Modulation	± 5 kHz at 25kHz	± 4 kHz at 20kHz	± 2.5 kHz at 12.5kHz
Operating Voltage	13.2V DC $\pm 15\%$		
Current Drain	Less than 0.4A on standby		
	Less than 1.0A on receive		
	Less than 8.0A on transmit		
Operating Temperature Range	-30°C to $+60^{\circ}\text{C}$		
Dimensions & Weight	140 W x 40 H x 145 D mm , 940g		
Channel Frequency Spread	28MHz		

RECEIVER (Measurements made per ETS standard)

Sensitivity (12dB SINAD) (EIA)	Wide : 0.25 μV	Semi wide : 0.25 μV	Narrow : 0.32 μV
Adjacent Channel Selectivity	Wide : 70dB	Semi wide : 70dB	Narrow : 60dB
Intermodulation	65dB		
Spurious Responce Rejection	70dB		
Audio Power Output	4.0W at 4 Ω , with less than 10% distortion		
Frequency Stability	± 2.5 ppm		

TRANSMITTER (Measurements made per ETS standard)

RF Power Output	5 to 25W		
Spurious Response	70dB		
FM Noise (EIA)	Wide : 50dB	Semi wide : 50dB	Narrow : 45dB
Modulation Distortion	Less than 3% at 1kHz		
Frequency Stability	± 2.5 ppm		

TK-760G/(N)/762G/(N)

KENWOOD CORPORATION

2967-3, Ishikawa-machi, Hachioji-shi, Tokyo 192-8525, Japan

KENWOOD U.S.A. CORPORATION

P.O. BOX 22745, 2201 East Dominguez Street, Long Beach, CA 90801-5745, U.S.A.

KENWOOD ELECTRONICS CANADA INC.

6070 Kestrel Road, Mississauga, Ontario, Canada L5T 1S8

KENWOOD ELECTRONICS DEUTSCHLAND GMBH

Rembrücker Str. 15, 63150 Heusenstamm, Germany

KENWOOD ELECTRONICS BELGIUM N.V.

Leuvensesteenweg 248 J, 1800 Vilvoorde, Belgium

KENWOOD ELECTRONICS FRANCE S.A.

13, Boulevard Ney, 75018 Paris, France

KENWOOD ELECTRONICS U.K. LIMITED

KENWOOD House, Dwight Road, Watford, Herts., WD18 9EB United Kingdom

KENWOOD ELECTRONICS EUROPE B.V.

Amsterdamseseweg 37, 1422 AC Uithoorn, The Netherlands

KENWOOD ELECTRONICS ITALIA S.p.A.

Via G. Sirtori, 7/9 20129 Milano, Italy

KENWOOD IBERICA S.A.

Bolivia, 239-08020 Barcelona, Spain

KENWOOD ELECTRONICS AUSTRALIA PTY. LTD.

(A.C.N. 001 499 074)

16 Giffnock Avenue, Centrecourt Estate, North Ryde, N.S.W. 2113 Australia

KENWOOD ELECTRONICS (HONG KONG) LTD.

Unit 3712-3724, Level 37, Tower one Metroplaza, 223 Hing Fong Road, Kwai Fong, N.T., Hong Kong

KENWOOD ELECTRONICS TECHNOLOGIES(S) PTE LTD.

Sales Marketing Division

1 Ang Mo Kio Street 63, Singapore 569110

