

VHF FM Transceiver
VX-410/-420 series
Service Manual

©2004 VERTEX STANDARD CO., LTD. EC050N90A

VERTEX STANDARD CO., LTD.
4-8-8 Nakameguro, Meguro-Ku, Tokyo 153-8644, Japan

VERTEX STANDARD
US Headquarters
10900 Walker Street, Cypress, CA 90630, U.S.A.

YAESU EUROPE B.V.
P.O. Box 75525, 1118 ZN Schiphol, The Netherlands

YAESU UK LTD.
Unit 12, Sun Valley Business Park, Winnall Close
Winchester, Hampshire, SO23 0LB, U.K.

VERTEX STANDARD HK LTD.
Unit 5, 20/F., Seaview Centre, 139-141 Hoi Bun Road,
Kwun Tong, Kowloon, Hong Kong

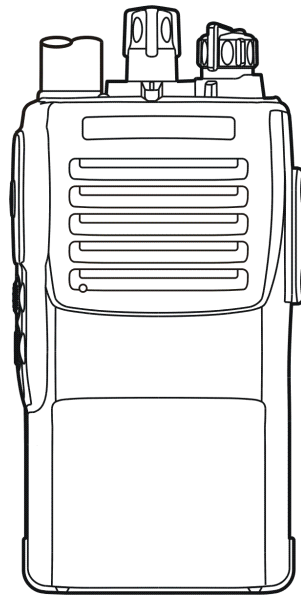

VX-410 series

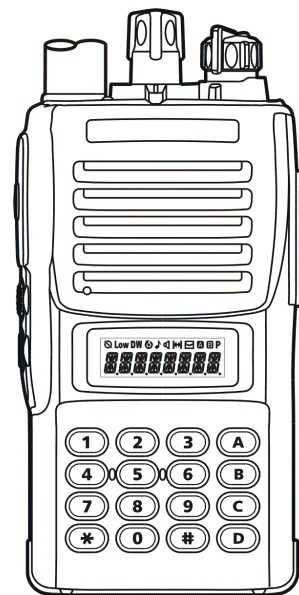

VX-420 series

Introduction

This manual provides technical information necessary for servicing the VX-410/-420 series FM Transceiver.

Servicing this equipment requires expertise in handling surface-mount chip components. Attempts by non-qualified persons to service this equipment may result in permanent damage not covered by the warranty, and may be illegal in some countries.

Two PCB layout diagrams are provided for each double-sided circuit board in the transceiver. Each side of is referred to by the type of the majority of components installed on that side (“leaded” or “chip-only”). In most cases one side has only chip components, and the other has either a mixture of both chip and leaded components (trimmers, coils, electrolytic capacitors, ICs, etc.), or leaded components only.

While we believe the technical information in this manual to be correct, VERTEX STANDARD assumes no liability for damage that may occur as a result of typographical or other errors that may be present. Your cooperation in pointing out any inconsistencies in the technical information would be appreciated.

Contents

Operating Manual Reprint	2
Cloning	7
Specifications	8
Exploded View & Miscellaneous Parts	9
Block Diagram	11
Circuit Description	13
Alignment	15

Board Unit (Schematics, Layouts & Parts)	
MAIN Unit	19
DUMMY Unit	34
Optional Units (Schematics, Layouts & Parts)	
FVP-25 Encryption / DTMF Pager Unit	35
VTP-50 VX-Trunk Unit	37
DVS-5 Voice Storage Unit	39

Operating Manual Reprint

Controls & Connectors

LED Indicator

Glows Green	Monitor on (or Side 1, 2 switch is activated : VX-410 series only)
Blinking Green	Busy Channel (or SQL off)
Glows Red	Transmitting
Blinking Red	Battery Voltage is low
Yellow	Receiving a Selective Call

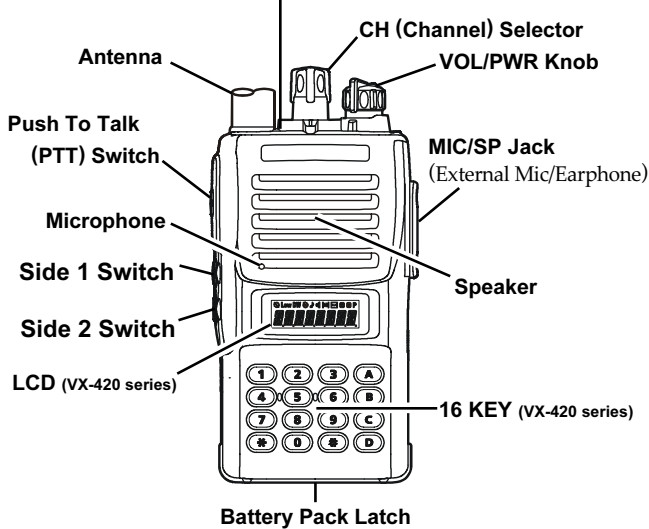

Display Icons & Indicators (VX-420 Only)

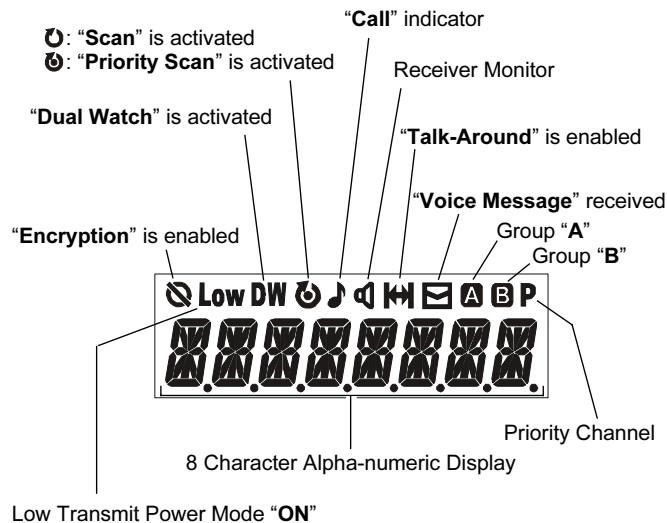

Before You Begin

Battery Pack Installation and Removal

- ❑ To install the battery, hold the transceiver with your left hand, so your palm is over the speaker and your thumb is on the top of the belt clip. Insert the battery pack into the battery compartment on the back of the radio while tilting the Belt Clip outward, then close the Battery Pack Latch until it locks in place with a "Click."

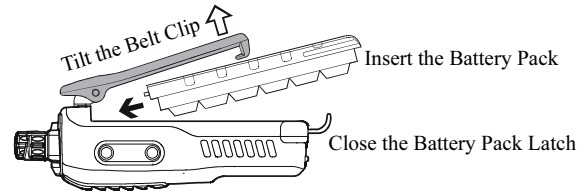

- ❑ To remove the battery, turn the radio off and remove any protective cases. Open the Battery Pack latch on the bottom of the radio, then slide the battery downward and out from the radio while holding the Belt Clip.

Caution!

Do not attempt to open any of the rechargeable Ni-Cd packs, as they could explode if accidentally short-circuited.

Low Battery Indication

- ❑ As the battery discharges during use, the voltage gradually becomes lower. When the battery voltage becomes to low, substitute a freshly charged battery and recharge the depleted pack. The **TX/BUSY** indicator on the top of the radio will blink **red** when the battery voltage is low.
- ❑ Avoid recharging Ni-Cd batteries often with little use between charges, as this can degrade the charge capacity. We recommend that you carry an extra, fully-charged pack with you so the operational battery may be used until depletion (this "deep cycling" technique promotes better long-term battery capacity).

Operation

Preliminary Steps

- Install a charged battery pack onto the transceiver, as described previously.
- Screw the supplied antenna onto the Antenna jack. Never attempt to operate this transceiver without an antenna connected.
- If you have a Speaker/Microphone, we recommend that it not be connected until you are familiar with the basic operation of the **VX-410/-420**.

Operation Quick Start

- Turn the top panel's **VOL/PWR** knob clockwise to turn on the radio on.

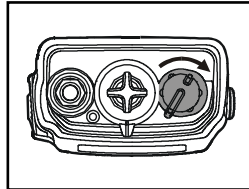

- Turn the top panel's **CH** selector knob to choose the desired operating channel.

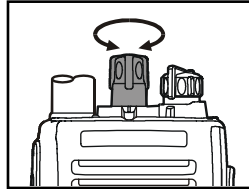

- Rotate the **VOL/PWR** knob to set the volume level. If no signal is present, press and hold in the **Soft** key assigned to "**MONITOR**" for more than 1 seconds; background noise will now be heard, and you may use this to set the **VOL/PWR** knob for the desired audio level.

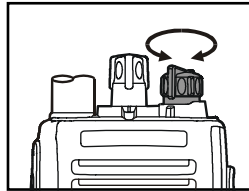

- Press and hold in the **Soft** key assigned to "**MONITOR**" for more than 1 seconds (or press the **MONITOR** key twice) to quiet the noise and resume normal (quiet) monitoring.

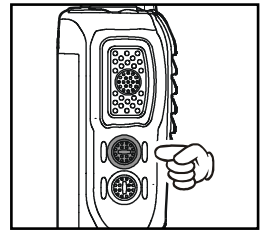

- To transmit, monitor the channel and make sure it is clear. **THIS IS AN FCC REQUIREMENT!**

- To transmit, press and hold in the **PTT** switch. Speak into the microphone area of the front panel grille (lower left-hand corner) in a normal voice level. To return to the Receive mode, release the **PTT** switch.

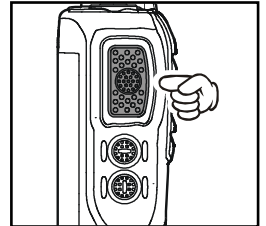

- If a Speaker/Microphone is available, remove the plastic cap and its two mounting screws from the right side of the transceiver, then insert the plug from the Speaker/Microphone into the **MIC/SP** jack; secure the plug using the screws supplied with the Speaker/Microphone. Hold the speaker grille up next to your ear while receiving. To transmit, press the **PTT** switch on the Speaker/Microphone, just as you would on the main transceiver's body.

Note: Save the original plastic cap and its mounting screws. They should be re-installed when not using the Speaker/Microphone.

Accessories & Options

FNB-64	7.2 V 700 mAh Ni-Cd Battery
FNB-V57	7.2 V 1100 mAh Ni-Cd Battery
FNB-V57IS	Intrinsically-Safe 7.2 V 1100 mAh Ni-Cd Battery
FNB-V67LI	7.4 V 1600 mAh Lithium-Ion Battery
FBA-25	Alkaline Battery Case
NC-77C	220-240 VAC Overnight Desktop Charger
NC-77U	230 VAC Overnight Desktop Charger
VAC-800	Desktop Rapid Charger (for FNB-64/-V57/-V57IS)
VAC-810	Desktop Rapid Charger (for FNB-V67LI)
VAC-6800	6-unit Multi Charger
MH-45_{B4B}	Speaker/Microphone
MH-37_{A4B}	Earpiece Microphone
VC-25	VOX Headset
VCM-1	Mobile Mounting Bracket (for VAC-800/-810)
CT-42	PC Programming Cable
CT-27	Radio to Radio Programming Cable
CE64	Programming Software
VTP-50	VX-Trunk Unit
FVP-25	Encryption/DTMF pager Unit
FVP-35	Encryption Unit (Rolling code voice scrambler)
DVS-5	Voice Storage Unit
MDC1200	Digital ANI encoder Unit

Operating Manual Reprint

Key Function

The **VX-420 series** provides programmable [A], [B], [C], and [D] function keys, and both the **VX-410 series** and **VX-420 series** provide programmable **Side 1** and **2** switches. These “**Soft**” keys functions can be customized (set to other functions), via programming by your **VERTEX STANDARD** dealer, to meet your communications/network requirements. Some features may require the purchase and installation of optional internal accessories. The possible **Soft** key programming features are illustrated below, and their functions are explained in the next chapter. For further details, contact your **VERTEX STANDARD** dealer.

For future reference, check the box next to each function that has been assigned to the **Soft** key on your particular radio, and keep it handy.

Function	Soft Key (Press / Press and Hold)					
	[A]	[B]	[C]	[D]	Side 1	Side 2
Monitor	/	/	/	/	/	/
Squelch Off	/	/	/	/	/	/
Low Power	/	/	/	/	/	/
Lock*	/	/	/	/	/	/
Lamp*	/	/	/	/	/	/
Channel Up*	/	/	/	/	/	/
Channel Down*	/	/	/	/	/	/
Scan	/	/	/	/	/	/
Follow-Me Scan	/	/	/	/	/	/
Dual Watch	/	/	/	/	/	/
Talkaround	/	/	/	/	/	/
Add/Del*	/	/	/	/	/	/
Reset	/	/	/	/	/	/
Speed Dial	/	/	/	/	/	/
Tx Save Off	/	/	/	/	/	/
Call 1	/	/	/	/	/	/
Call 2	/	/	/	/	/	/
Call 3	/	/	/	/	/	/
Code Select*	/	/	/	/	/	/
Code Up*	/	/	/	/	/	/
Code Down*	/	/	/	/	/	/
Emergency	-/	-/	-/	-/	-/	-/
Group	/	/	/	/	/	/
ACC 1	/	/	/	/	/	/
ACC 2	/	/	/	/	/	/
Play	/	/	/	/	/	/
Record	/	/	/	/	/	/
Encryption	/	/	/	/	/	/

* VX-420 series only

Description of Operating Functions

Monitor

Press (or Press and hold) the assigned **Soft** key momentarily to disable the Tone squelch.

Squelch Off

Press (or Press and hold) the assigned **Soft** key to disable the Noise and Tone squelch. Again press (or Press and hold) the assigned **Soft** key to resume normal (quiet) Noise and Tone squelch action.

Low Power

Press (or Press and hold) the assigned **Soft** key to set the radio’s transmitter to the “Low Power” mode, thus extending battery life. Press (or Press and hold) the assigned **Soft** key again to return to “High Power” operation when in difficult terrain.

When the radio’s transmitter is set to “Low Power” mode, the “**Low**” icon will be indicated on the display.

Lock

Press (or Press and hold) the assigned **Soft** key to lock the **Soft** keys (except *Lock* key); thus, the [A], [B], [C], and [D] keys can be disabled to prevent radio settings from being disturbed.

Lamp

Press (or Press and hold) the assigned **Soft** key to illuminate the LCD for five seconds.

Channel Up

Press (or Press and hold) the assigned **Soft** key to switch to a higher operating channel number.

Channel Down

Press (or Press and hold) the assigned **Soft** key to switch to a lower operating channel number.

Scan

The Scanning feature is used to monitor multiple channels programmed into the transceiver. While scanning, the radio will check each channel for the presence of a signal, and will stop on a channel if a signal is present.

To activate scanning:

Press (or Press and hold) the assigned **Soft** key.

The scanner will search the channels, looking for active ones; it will pause each time it finds a channel on which someone is speaking.

To stop scanning:

Press (or Press and hold) the assigned **Soft** key.

Operation will revert to the channel to which the **CH** knob is set.

Description of Operating Functions

Follow-Me Scan

“Follow-Me” Scan feature checks a *User-assigned* Priority Channel regularly as you scan the other channels. Thus, if only Channels 1, 3, and 5 (of the 8 available channels) are designated for “Scanning,” the user may nonetheless assign Channel as the “User-assigned” Priority Channel via the “Follow-Me” feature.

Press the assigned **Soft** key to activate “Follow-Me” scanning, then turn the **CH** selector knob to the channel which you want to designate as the “User-Assigned Priority Channel”. When the scanner stops on an “active” channel, the User-assigned Priority Channel will automatically be checked every few seconds.

Dual Watch

The Dual Watch feature is similar to the Scan feature, except that only two channels are monitored: the current operating channel, and the “Priority” channel.

To activate Dual Watch:

Press (or Press and hold) the assigned **Soft** key.

The scanner will search the two channels; it will pause each time it finds a channel on which someone is speaking.

To stop Dual Watch:

Press (or Press and hold) the assigned **Soft** key.

Operation will revert to the channel to which the **CH** knob is set.

Talk Around

Press (or Press and hold) the assigned **Soft** key to activate the Talk Around feature when you are operating on duplex channel systems (separate receive and transmit frequencies, utilizing a “repeater” station). The Talk Around feature allows you to bypass the repeater station and talk directly to a station that is nearby. This feature has no effect when you are operating on “Simplex” channels, where the receive and transmit frequencies are already the same.

When the “TA” function is activated, the “” icon will be indicated on the display.

Note that your dealer may have made provision for “Talk Around” channels by programming “repeater” and “Talk Around” frequencies on two adjacent channels. If so, the key may be used for one of the other Pre-Programmed Functions.

Add/Del

The Add/Del feature allows the user to arrange a custom Scan.

Press (or Press and hold) the assigned **Soft** key to delete/restore the current channel to/from your scanning list.

When you delete a current channel, “-SKIP-” will appear on the LCD for one second after pressing the **Soft** key. When you restore a current channel, “-STOP-” will appear on the LCD for one second after pressing the **Soft** key.

Speed Dial

Your Dealer may have pre-programmed Auto-Dial telephone number memories into your radio.

To dial a number, just press (or Press and hold) the Dealer-assigned **Soft** key for Speed Dialing. The DTMF tones sent during the dialing sequence will be heard in the speaker.

TX Save Off

Press (or Press and hold) the assigned **Soft** key to disable the Transmit Battery Saver, if you are operating in a location where high power is almost always needed.

The Transmit Battery Saver helps extend battery life by reducing transmit power when a very strong signal from an apparently nearby station is being received. Under some circumstances, though, your hand-held radio may not be heard well at the other end of the communication path, and high power may be necessary at all times.

Call 1, 2, 3/Reset

When the 2-tone or 5-Tone selective calling unit is installed, press (or Press and hold) the assigned **Soft** key to silence the receiver and reset for another call, when a communication is finished.

Code Select

Press (or Press and hold) the assigned **Soft** key to enable the changing the 5-Tone Paging code which is recalled by the “**Call 1**” key.

Code Up, Down

Press (or Press and hold) the assigned **Soft** key to switch to a higher (or lower) paging code number for the 5-Tone Paging System.

Operating Manual Reprint

Description of Operating Functions

Emergency

The VX-410/-420 series includes an “Emergency” feature, which may be useful, if you have someone monitoring on the same frequency as your transceiver’s channel. For further details contact your **VERTEX STANDARD** dealer.

Group

Press (or Press and hold) the assigned **Soft** key to select a “**A**” or “**B**” group of channels.

Once the desired Group is reached, rotate the **CH** knob to select the desired channel within the selected Group.

ACC 1, 2

When the optional unit is installed, these functions are various uses.

For further details, contact your **VERTEX STANDARD** dealer.

REC/PLAY (Voice Storage: Option)

This function, which requires the optional Voice Storage Unit, Allows you to record and play back incoming receiver audio.

Recording:

Press (or Press and hold) the assigned **Soft** key to toggle the recording feature “on” and “off.” If the incoming signal is being heard through the speaker when the recording feature is set to “on,” the received audio will be recorded. The last 2 minutes of incoming audio will be stored on a first-in, first-out basis.

Playback:

Press (or Press and hold) the assigned **Soft** key to start playback. During playback, pressing then “#” key lets you jump forward 8 seconds, while pressing the “*” key lets you go back 8 seconds. To stop playback before the stored message is complete, press (or Press and hold) the assigned **Soft** key.

Encryption

When the Voice Scrambler feature is enabled, pressing the assigned **Soft** key of the “Encryption” toggles the Scrambler “on” and “off.”

ARTS (Auto Rande Transpond System : VX-420 only)

This system is designed to inform you when you and another **ARTS**-equipped station are within communication range.

During **ARTS** operation, your radio automatically transmits for about 1 second every 55 seconds in an attempt to shake hands with the other station.

If you have out of range for more than two minutes, your radio senses that no signal has been received, a ringing beeper will sound, and “IN RANGE” will appear on the LCD. If you subsequently move back into range, as soon as the other station transmits, your beeper will sound and “OUT RANGE” will appear on the LCD.

DTMF Paging System (VX-420 only)

This system allows paging and selective calling, using DTMF tone sequences.

When your radio is paged by a station bearing a tone sequence which matches yours, your radio’s squelch will open and the alert will sound. The three-digit code of the station which paged you will be displayed on your radio’s LCD.

Cloning

The **VX-410/-420** series includes a convenient “Cloning” feature, which allows the programming data from one transceiver to be transferred to another **VX-410/-420** series. Here is the procedure for Cloning one radio's data to another.

1. Turn both transceivers off.
2. Remove the plastic cap and its two mounting screws from the **MIC/SP** jack on the right side of the transceiver. Do this for both transceivers.
3. Connect the optional **CT-27** cloning cable between the **MIC/SP** jacks of the two transceivers.
4. Press and hold in the **PTT** and **Soft** key assigned to “**MONITOR**” while turning the transceiver on. Do this for both transceivers (the order of the switch-on does not matter). “**CLONE**” will appear on the displays (for the **VX-420** series) of both transceivers when Clone mode is successfully activated in this step; in the case of the **VX-410** series, no change will be observed at this point.
5. On the Destination transceiver, press the **Soft** key assigned to “**MONITOR**”. “**LOADING**” will appear on the LCD (for **VX-420** series; for **VX-410** series, the **TX/BUSY** indicator on the top of the radio will glow Green).
6. Press the **PTT** switch on the source transceiver; “**SENDING**” will appear on the Source transceiver (for **VX-420** series; for **VX-410** series, the **TX/BUSY** indicator on the top of the radio will glow Red), and the data will be transferred.
7. If there is a problem during the cloning process, “**ERROR**” will appear on the LCD (for **VX-420** series; for **VX-410** series, the **TX/BUSY** indicator on the top of the radio will blink Red); check your cable connections and battery voltage, and try again.
8. If the data transfer is successful, the display will return to “**CLONE**” (for **VX-420** series; for **VX-410** series, the **TX/BUSY** indicator on the top of the radio will turn off). Turn both transceivers off and disconnect the **CT-27** cable. You can then turn the transceivers back on, and begin normal operation.
9. Replace the plastic cap and its two mounting screws.

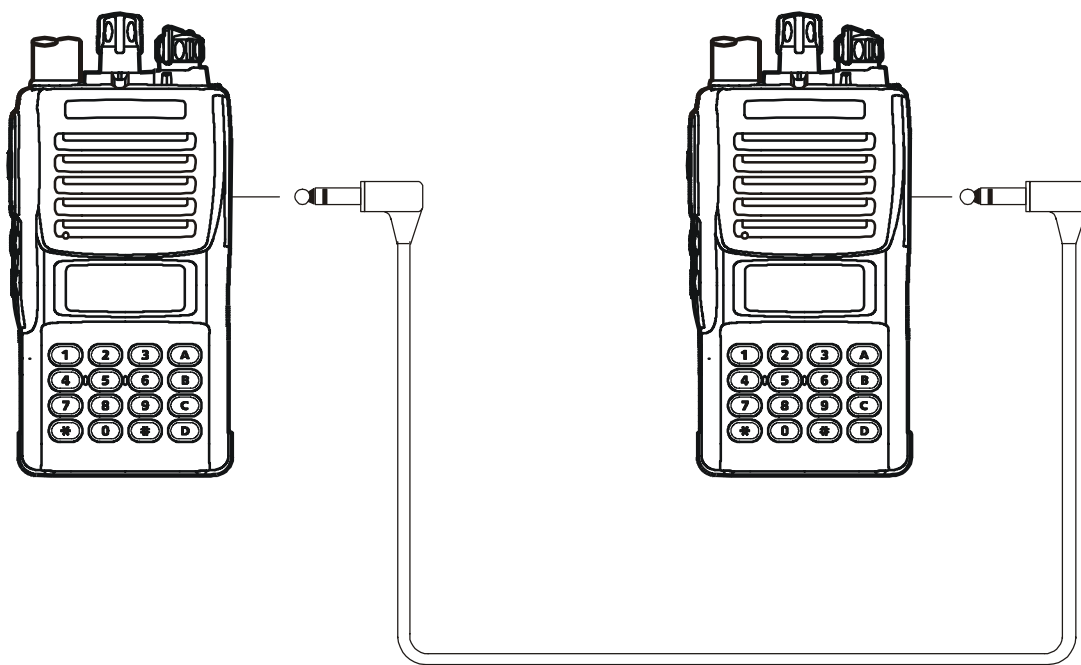

Optional Cloning Cable **CT-27**

Specifications

GENERAL Specifications

Frequency Range:	146 - 174 MHz
Number of Channels:	32 channels
Channel Spacing:	2.5 / 6.25 kHz
PLL Steps	5 / 6.25 kHz
Power Supply voltage:	7.5 VDC \pm 10%
Operating Temperature Range:	-22°F to +140°F (-30°C to +60°C)
Frequency Stability:	\pm 2.5 ppm
Dimensions (WHD):	2.3" (W) x 4.3" (H) x 1.2" (D) (58 x 108 x 29 mm)
Weight (approx.):	0.78 lb. (350 g) w/FNB-V57, Antenna and Belt clip

RECEIVER Specifications (Measurements made per EIA standard TIA/EIA-603)

Sensitivity

EIA 12 dB SINAD : 0.25 μ V

Adjacent channel selectivity:	70 dB (25 kHz) / 60 dB (12.5 kHz)
Intermodulation:	70 dB (25 kHz) / 65 dB (12.5 kHz)
Spurious and Image Rejection:	70 dB
Hum & Noise	45 dB
Audio output:	500 mW @4 Ohms, 10% THD

TRANSMITTER Specifications (Measurements made per EIA standard TIA/EIA-603)

Power output:	5.0 / 1.0 W
Modulation:	16K0F3E, 11K0F3E
Conducted Spurious Emissions:	70 dB Below Carrier
FM Hum & Noise:	45 dB (25 kHz) / 40 dB (12.5 kHz)
Audio distortion (@ 1 kHz):	< 5 %

Measurements per EIA standards unless noted above. Specifications subject to change without notice or obligation.

Exploded View & Miscellaneous Parts

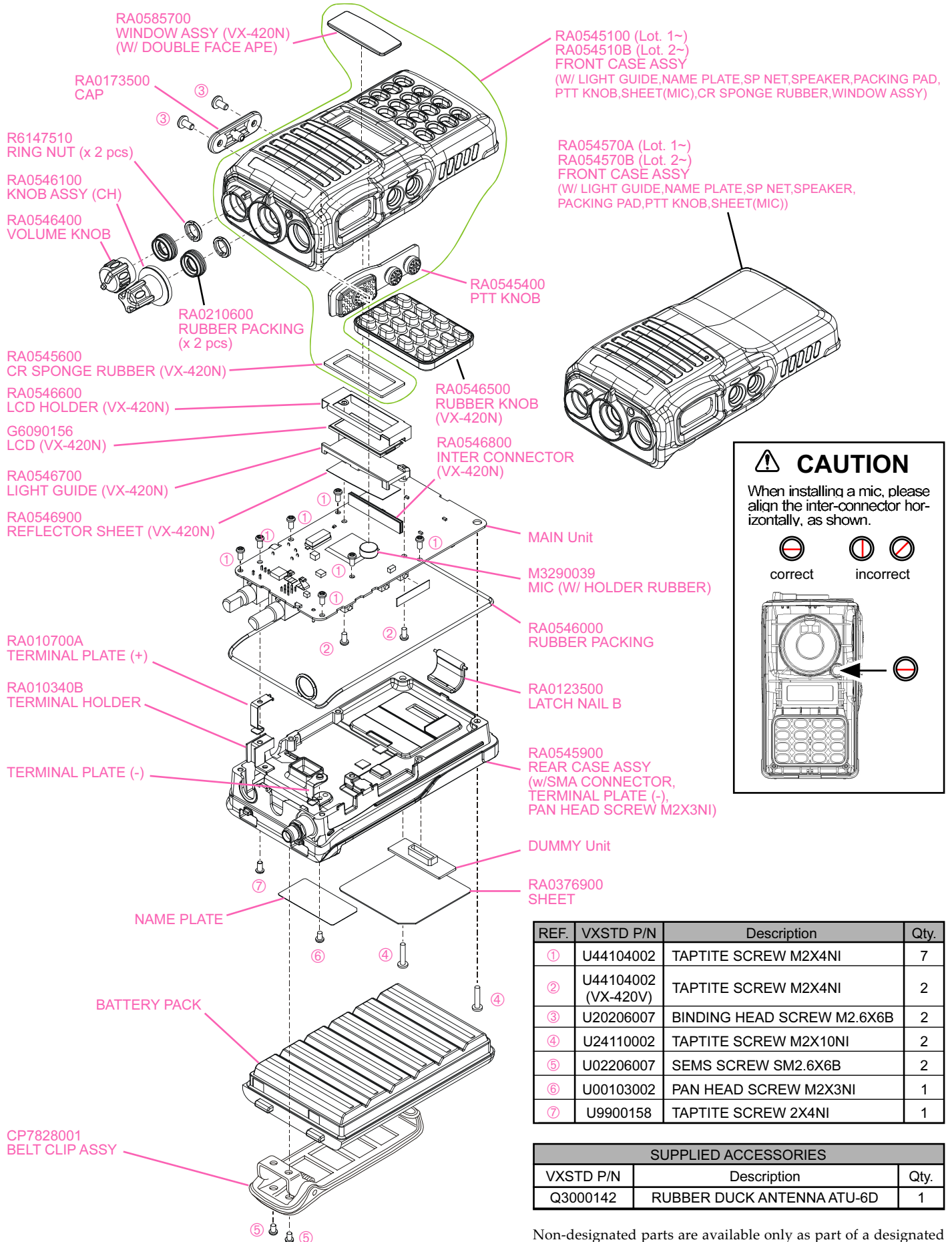

CAUTION

When installing a mic, please align the inter-connector horizontally, as shown.

correct incorrect

REF.	VXSTD P/N	Description	Qty.
①	U44104002	TAPTITE SCREW M2X4NI	7
②	U44104002 (VX-420V)	TAPTITE SCREW M2X4NI	2
③	U20206007	BINDING HEAD SCREW M2.6X6B	2
④	U24110002	TAPTITE SCREW M2X10NI	2
⑤	U02206007	SEMS SCREW SM2.6X6B	2
⑥	U00103002	PAN HEAD SCREW M2X3NI	1
⑦	U9900158	TAPTITE SCREW 2X4NI	1

SUPPLIED ACCESSORIES		
VXSTD P/N	Description	Qty.
Q3000142	RUBBER DUCK ANTENNA ATU-6D	1

Non-designated parts are available only as part of a designated assembly.

Note:

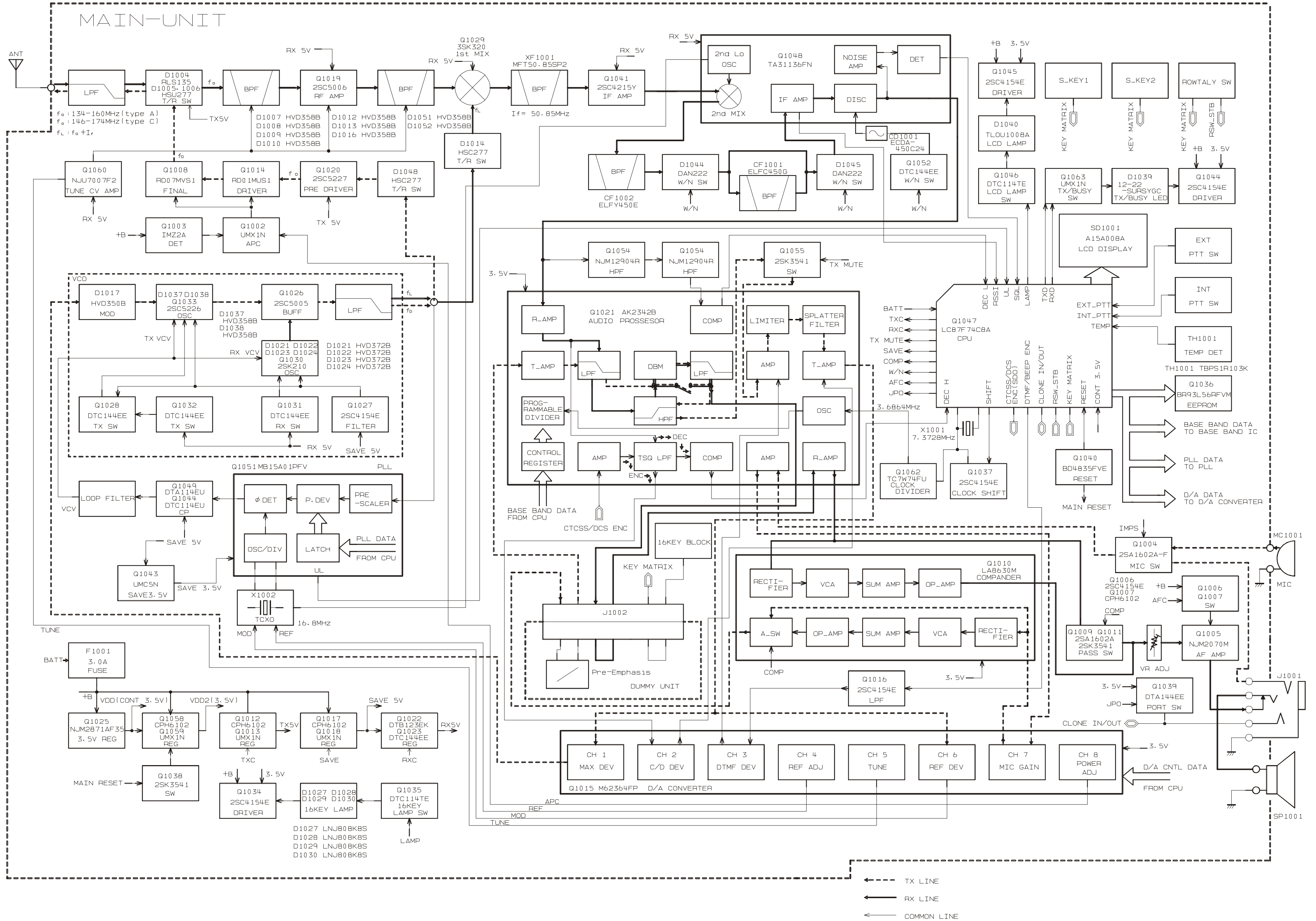

Note:

Receive Signal Path

Incoming RF from the antenna jack is delivered to the RF Unit and passes through a low-pass filter consisting of coils L1002, and L1003, capacitors C1001, C1002, C1021, C1024, C1025, C1026, and C1027, and antenna switching diode D1004 (**RLS135**).

Signals within the frequency range of the transceiver enter a varactor-tuned band-pass filter consisting of coils L1012 and L1015, capacitors C1058, C1059, C1085, C1118, and C1119, and diodes D1007, D1008, D1009, and D1010 (all **HVD350B**), then are amplified by Q1019 (**2SC5006**) and enter a varactor-tuned band-pass filter consisting of coils L1020, and L1025, capacitors C1053, C1054, C1056, C1180, and C1181, and diodes D1012, D1013, and D1016 (all **HVD350B**), before application to the first mixer, Q1029 (**3SK320**).

Buffered output from the VCO is amplified by Q1026 (**2SC5005**) to provide a pure first local signal between 196.85 and 224.85 MHz for injection to the first mixer Q1029. The 50.85 MHz first mixer product then passes through monolithic crystal filter XF1001 (**MFT50.85PT**, 5.5 kHz BW) to strip away unwanted mixer products, and is then amplified by Q1041 (**2SC4215Y**).

The amplified first IF signal is applied to FM IF subsystem IC Q1048 (**TA31136FN**), which contains the second mixer, second local oscillator, limiter amplifier, noise amplifier, and RSSI amplifier.

The second local signal is produced from the PLL reference/second local oscillator of X1002 (TCXO TTS05VS-M1 16.80 MHz). The 16.80 MHz reference signal is tripled by Q1048, capacitor C1251, and coil L1042, and the resulting the 50.4 MHz second local signal is then delivered to the mixer section of Q1048 which produces the 450 kHz second IF when mixed with the first IF signal.

The second IF then passes through the ceramic filter CF1001 (**ELFC450G** on “Narrow” channels) or CF1002 (**ELFY450E** on “Wide” and “Narrow” channels) to strip away all but the desired signal, and is then applied to the limiter amplifier in Q1048, which removes amplitude variations in the 450 kHz IF, before detection of the speech by the ceramic discriminator CD1001 (**ECDA450C24**).

Squelch Control

The squelch circuitry consists of a noise amplifier, band-pass filter, and noise detector within Q1048 (**TA31136FN**).

When no carrier is received, noise at the output of the detector stage in Q1048 is amplified and band-pass filtered by the noise amplifier section of Q1048 and the network between pins 7 and 8, and then is rectified by detection circuit in Q1048.

The resulting DC squelch control voltage is passed to

pin 19 of the microprocessor Q1047 (**LC87F74C8A**). If no carrier is received, this signal causes pin 19 of Q1047 to go high and pin 30 to go high. Pin 35 signals Q1006 (**2SC4154E**) to disable the supply voltage to the audio amplifier Q1005, while pin 30 holds the green (Busy) half of the LED off, when pin 35 is high and pin 30 is high.

Thus, the microprocessor blocks output from the audio amplifier, and silences the receiver, while no signal is being received (and during transmission, as well).

When a carrier appears at the discriminator, noise is removed from the output, causing pin 19 of Q1047 to go low and the microprocessor to activate the “Busy” LED via Q1047.

The microprocessor then checks for CTCSS or CDCSS code squelch information, if enabled. If not transmitting and CTCSS or CDCSS is not activated, or if the received tone or code matches that programmed, audio is allowed to pass through the audio amplifier Q1005 (**NJM2070M**) to the loudspeaker by the enabling of the supply voltage to it via Q1048.

Transmit Signal Path

Speech input from the microphone MC1001 passes through the audio amplifier Q1021 (**AK2342B**) to Q1015 (**M62364FP**) which adjusts the microphone gain. The adjusted audio is applied to the compander Q1010 (**LA8630M**) which compresses the speech signal according to a control command from the microprocessor Q1047 (**LC87F74C8A**).

The compressed speech signal passes through the dummy unit and pre-emphasis circuit to Q1021, which contains the low-pass filter, Voice Scrambler selector, and high-pass filter.

The output from Q1021 is applied to the AF mute gate Q1055 (**2SK3541**), then returns to Q1021, which contains the limiter amplifier, splatter filter and audio amplifier.

The filtered audio signal is applied to Q1015 (**M62364FP**) which is adjusts the audio level, then is applied to varactor diode D1017 (**HVD350B**), which frequency modulates the VCO Q1033 (**2SK508**). A portion of the audio signal from Q1015 is applied to TCXO X1002 (**TTS05VS**).

The processed audio may then be mixed with a CTCSS tone generated by Q1047 (**LC87F74C8A**) for frequency modulation of the PLL carrier (up to ± 5 kHz from the unmodulated carrier) at the transmitting frequency.

If a CDCSS code is enabled for transmission, the code is generated by microprocessor Q1047 and delivered to X1002 (**TCXO TTS05VS**) for CDCSS modulating.

The modulated signal from the VCO Q1033 (**2SC5226**) is buffered by Q1026 (**2SC5005**). The low-level transmit signal then passes through the T/R switching diode D1048 (**HSC277TRF**) to the driver amplifier

Circuit Description

Q1014 (**2SK2596BXTL**), and then the amplified transmit signal is applied to the final amplifier Q1008 (**RD07MVS1**), which delivers up to 5 watts of output power.

The transmit signal then passes through the antenna switch D1004 (**RLS135**) and is low-pass filtered, to suppress harmonic spurious radiation before delivery to the antenna.

Automatic Transmit Power Control

Current from the final amplifier is sampled by R1015, R1038 and R1040, and is rectified by Q1003 (**IMZ2A**). The resulting DC is fed back through Q1002 (**UMX1**) to the drive amplifier Q1014 and final amplifier Q1008, for control of the power output.

The microprocessor selects “High” or “Low” power levels.

Transmit Inhibit

When the transmit PLL is unlocked, pin 7 of PLL IC Q1005 (**MB15A01PFV**) goes to a logic “Low.” The resulting DC unlock control voltage is passed to pin 10 of the microprocessor Q1047. While the transmit PLL is unlocked, pin 31 of Q1047 remains high, which then turns off Q1012 (**CPH6102**) and the Automatic Power Controller Q1002 (**UMX1**) to disable the supply voltage to the drive amplifier Q1014, Q1020 and final amplifier Q1008, thereby disabling the transmitter.

Spurious Suppression

Generation of spurious products by the transmitter is minimized by the fundamental carrier frequency being equal to final transmitting frequency, modulated directly in the transmit VCO. Additional harmonic suppression is provided by a low-pass filter consisting of coils L1002, and L1003 plus capacitors C1001, C1002, C1021, C1023, C1024, C1025, C1026, and C1027, resulting in more than 60 dB of harmonic suppression prior to delivery of the RF signal to the antenna.

PLL Frequency Synthesizer

The PLL circuitry on the Main Unit consists of VCO Q1030 (**2SK210GR**), Q1033 (**2SC5226**), VCO buffer Q1026 (**2SC5005**), and PLL subsystem IC Q1051 (**MB15A01PFV1**), which contains a reference divider, serial-to-parallel data latch, programmable divider, phase comparator and charge pump, and TCXO unit X1002 (**TTS05VS**) which yields frequency stability of ± 2.5 ppm @ -22°F to $+140^{\circ}\text{F}$ (-30°C to $+60^{\circ}\text{C}$).

While receiving, VCO Q1030 oscillates between 196.85 and 224.85 MHz according to the transceiver version and the programmed receiving frequency. The VCO output is buffered by Q1026, then applied to the prescaler section of Q1051. There the VCO signal is divided by 64 or 65, according to a control signal from the data latch

section of Q1051, before being sent to the programmable divider section of Q1051.

The data latch section of Q1051 also receives serial dividing data from the microprocessor Q1047, which causes the pre-divided VCO signal to be further divided in the programmable divider section, depending upon the desired receive frequency, so as to produce a 2.5 kHz or 3.125 kHz derivative of the current VCO frequency.

Meanwhile, the reference divider section of Q1051 divides the 16.80 MHz crystal reference from the reference oscillator Q1051, by 6720 (or 5376) to produce the 2.5 kHz (or 3.125 kHz) loop references (respectively).

The 2.5 kHz (or 3.125 kHz) signal from the programmable divider (derived from the VCO) and that derived from the reference oscillator are applied to the phase detector section of Q1051, which produces a pulsed output with pulse duration depending on the phase difference between the input signals.

This pulse train is filtered to DC and returned to varactors D1021, D1022, D1023, and D1024 (all **HVD372B**). Changes in the level of the DC voltage are applied to the varactors, affecting the reference in the tank circuit of the VCO according to the phase difference between the signals derived from the VCO and the crystal reference oscillator.

The VCO is thus phase-locked to the crystal reference oscillator. The output of the VCO Q1030 (**2SK210GR**), after buffering by Q1026, is applied to the first mixer as described previously.

For transmission, the VCO Q1033 (**2SC5226**) oscillates between 146.00 and 174.00 MHz according to the model version and programmed transmit frequency. The remainder of the PLL circuitry is shared with the receiver. However, the dividing data from the microprocessor is such that the VCO frequency is at the actual transmit frequency (rather than offset for IFs, as in the receiving case). Also, the VCO is modulated by the speech audio applied to D1017 (**HVC350B**), as described previously.

Receive and transmit buses select which VCO is made active, using Q1028, Q1031, Q1032 (all **DTC144EE**).

Miscellaneous Circuits

Push-To-Talk Transmit Activation

The PTT switch on the microphone is connected to pin 22 of microprocessor Q1047, so that when the PTT switch is closed, pin 27 of Q1047 goes high. This signal disables the receiver by disabling the 5 V supply bus at Q1022 (**DTB123EK**) to the front-end, FM IF subsystem IC Q1048 and the receiver VCO circuitry.

At the same time, Q1013 (**UMX1N**) and Q1012 (**CPH6102**) activate the transmit 5V supply line to enable the transmitter.

Introduction

The **VX-410/-420** series has been aligned at the factory for the specified performance across the entire frequency range specified. Realignment should therefore not be necessary except in the event of a component failure. All component replacement and service should be performed only by an authorized Vertex Standard representative, or the warranty policy may be voided.

The following procedures cover the sometimes critical and tedious adjustments that are not normally required once the transceiver has left the factory. However, if damage occurs and some parts are replaced, realignment may be required. If a sudden problem occurs during normal operation, it is likely due to component failure; realignment should not be done until after the faulty component has been replaced.

We recommend that servicing be performed only by authorized Vertex Standard service technicians who are experienced with the circuitry and fully equipped for repair and alignment. Therefore, if a fault is suspected, contact the dealer from whom the transceiver was purchased for instructions regarding repair. Authorized Vertex Standard service technicians realign all circuits and make complete performance checks to ensure compliance with factory specifications after replacing any faulty components. Those who do undertake any of the following alignments are cautioned to proceed at their own risk. Problems caused by unauthorized attempts at realignment are not covered by the warranty policy. Also, Vertex Standard must reserve the right to change circuits and alignment procedures in the interest of improved performance, without notifying owners. Under no circumstances should any alignment be attempted unless the normal function and operation of the transceiver are clearly understood, the cause of the malfunction has been clearly pinpointed and any faulty components replaced, and the need for realignment determined to be absolutely necessary. The following test equipment (and thorough familiarity with its correct use) is necessary for complete realignment. Correction of problems caused by misalignment resulting from use of improper test equipment is not covered under the warranty policy. While most steps do not require all of the equipment listed, the interactions of some adjustments may require that more complex adjustments be performed afterwards. Do not attempt to perform only a single step unless it is clearly isolated electrically from all other steps. Have all test equipment ready before beginning, and follow all of the steps in a section in the order presented.

Required Test Equipment

- Avionics Radio Tester with calibrated output level at 1 GHz
- In-line Wattmeter with 5% accuracy at 500 MHz
- 50-ohm, 10-W RF Dummy Load
- Regulated DC Power Supply (standard 7.5V DC, 2A)
- Frequency Counter: ± 0.2 ppm accuracy at 500 MHz
- AF Signal Generator
- AC Voltmeter
- DC Voltmeter
- VHF Sampling Coupler
- Microsoft® Windows®95 or later operating system
- Vertex Standard CT-42 Connection Cable and CE64 Alignment program

Alignment Preparation & Precautions

A 50-ohm RF Dummy load and in-line wattmeter must be connected to the main antenna jack in all procedures that call for transmission, except where specified otherwise. Correct alignment is not possible with an antenna.

After completing one step, read the following step to determine whether the same test equipment will be required. If not, remove the test equipment (except dummy load and wattmeter, if connected) before proceeding.

Correct alignment requires that the ambient temperature be the same as that of the transceiver and test equipment, and that this temperature be held constant between 68°~ 86°F (20° and 30°C). When the transceiver is brought into the shop from hot or cold air, it should be allowed time to come to room temperature before alignment.

Whenever possible, alignments should be made with oscillator shields and circuit boards firmly affixed in place. Also, the test equipment must be thoroughly warmed up before beginning.

Note: Signal levels in dB referred to in this procedure are based on $0 \text{ dB}\mu = 0.5 \mu\text{V}$ (closed circuit).

Important Note

When connecting the **CT-42** plug into the **MIC/SP** jack of the **VX-410/-420** series, you must remove the plastic cap and its mounting screws prior to programming. Please remember to re-attach the cap and screws when the programming is complete.

Alignment

Set up the test equipment as shown below for transceiver alignment, and apply 7.5V DC power to the transceiver.

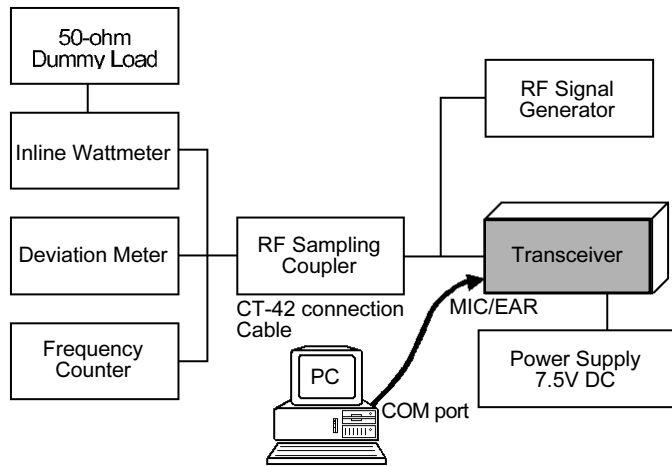

The transceiver must be programmed for use in the intended system before alignment is attempted. The RF parameters are loaded from the file during the alignment process.

In order to facilitate alignment over the complete operating range of the equipment, it is recommended that the channel data in the transceiver be preset as per the chart below.

Channels	Frequency	CTCSS Tone	DCS code
Low Band Edge (Channel 1)	146.000 MHz	–	–
Band Center (Channel 2)	160.000 MHz	151.4 Hz	–
High Band Edge (Channel 3)	174.000 MHz	–	627

The alignment tool outline

Installation of the Alignment tool

The “alignment mode” is a software-based protocol, accessed by an “Alignment Mode” command from the computer while switching the transceiver on. It is operated by the alignment tool automatically. During use of the alignment mode, normal operation is suspended. The alignment tool program provides all needed operation capability.

Alignment Sequence

Although the data displayed on the computer’s screen during alignment is temporary data, it is important you follow the basic alignment sequence precisely, so that the displayed data and the data loaded into the transceiver are identical.

Basic Alignment Sequence

1. Enter the alignment mode
2. Upload data from transceiver
3. Align data
4. Download data to transceiver

PLL VCV (Varactor Control Voltage)

- Connect the DC voltmeter between **TP1045** on the Main Unit and ground.
- Set the transceiver to CH 3 (high band edge), and adjust **L1036** on the Main Unit for $3.7\text{ V} \pm 0.1\text{ V}$ on the DC voltmeter.
- Set the transceiver to CH 1 (low band edge), and confirm the low-end VCV is more than 1.2 V while receiving.
- Set the transceiver to CH 3 (high band edge), and adjust **L1038** on the Main Unit for $3.6\text{ V} \pm 0.1\text{ V}$ while transmitting.
- Set the transceiver to CH 1 (low band edge), and confirm the low-end VCV is more than 1.1 V while transmitting.

Reference Frequency

- Set the transceiver to CH 2 (band center) via the “CH” box on the “Alignment” window previously.
- To adjustment, click the left mouse button on the “RF Frequency” box, then press the [ENTER] key to open the pop-up window.
- Use the [←] or [→] arrow keys so that the frequency counter displays the band center frequency ($\pm 100\text{ Hz}$) for the version being aligned.
- Press the “OK” box to lock in the new data.

Transmitter Output Power

- Set the transceiver to CH 2 (band center).
- To adjustment, click the left mouse button on the “RF Power {High}” or “RF Power {Low}” box, then press the [ENTER] key to open the pop-up window.
- Use the [←] or [→] arrow keys so that the power meter reading is 5.0 W ($\pm 0.1\text{ W}$) (for “RF Power High”) or 1.0 W ($\pm 0.1\text{ W}$) (for “RF Power Low”). Confirm that the current consumption is 2.3 A or lower (for “RF Power High”) or 1.0 A or lower (for “RF Power Low”).
- Press the “OK” box to lock in the new data.

MAX Deviation

- Set the transceiver to CH 2 (band center).
- Inject a 1 kHz tone at -17 dBm to the MIC jack.
- To adjustment, click the left mouse button on the “MAX Deviation” box, then press the [ENTER] key to open the pop-up window.
- Use the [←] or [→] arrow keys so that the deviation meter reading is $\pm 4.3\text{ kHz}$ ($\pm 0.1\text{ kHz}$) (for 25 kHz steps) or $\pm 2.1\text{ kHz}$ ($\pm 0.1\text{ kHz}$) (for 12.5 kHz steps) deviation.
- Press the “OK” box to lock in the new data.

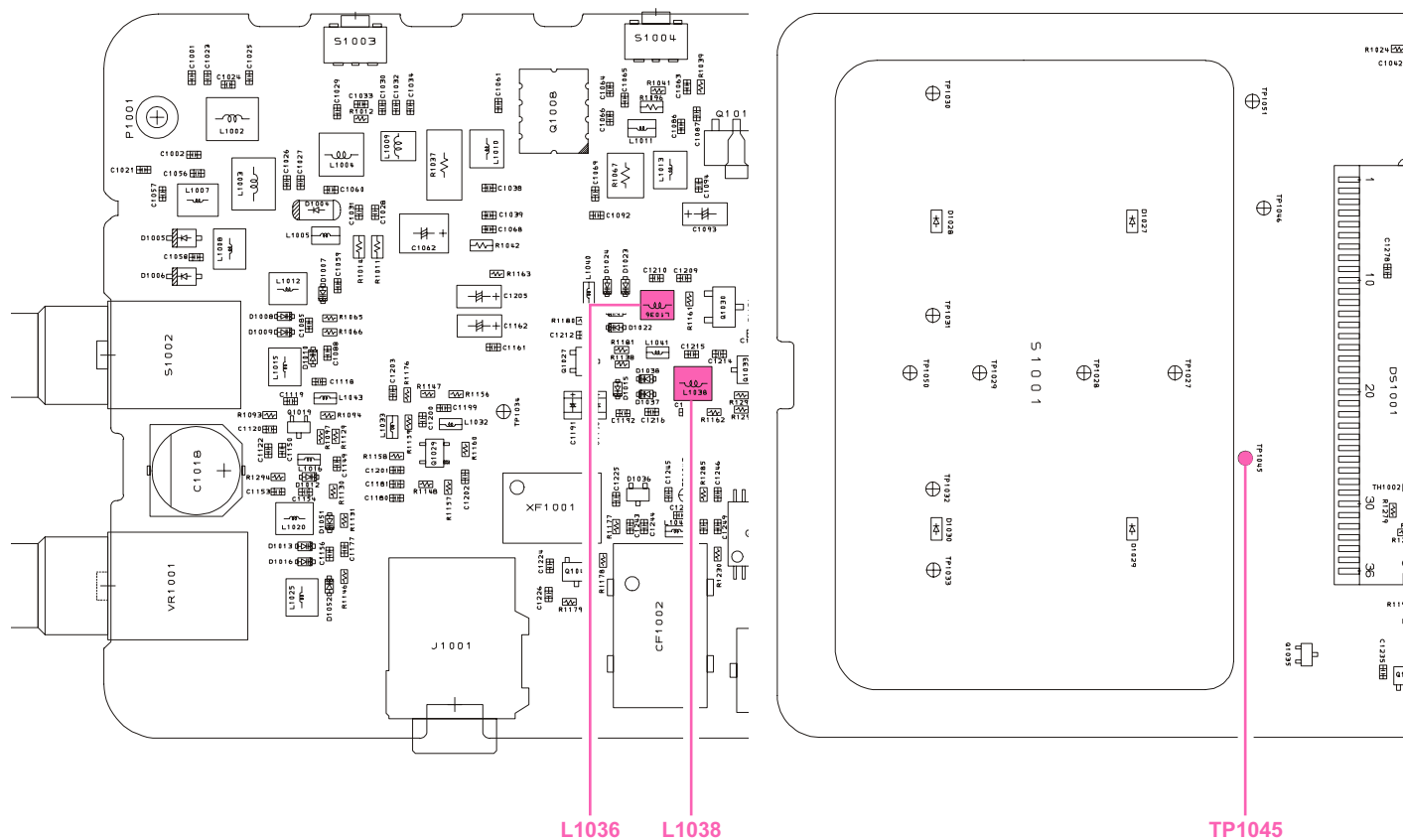

Alignment

CTCSS Deviation

- Set the transceiver to CH 2 (band center).
- To adjustment, click the left mouse button on the “CTCSS Modulation” box, then press the [ENTER] key to open the pop-up window.
- Use the [←] or [→] arrow keys so that the deviation meter reading is ± 0.8 kHz (± 0.1 kHz) (for 25 kHz steps) or ± 0.5 kHz (± 0.1 kHz) (for 12.5 kHz steps) deviation.
- Press the “OK” box to lock in the new data.

MAX Ref Deviation

- Set the transceiver to CH 2 (band center).
- To adjustment, click the left mouse button on the “MAX Ref Deviation” box, then press the [ENTER] key to open the pop-up window.
- Use the [←] or [→] arrow keys so that the deviation meter reading is ± 0.6 kHz (± 0.2 kHz) (for 25 kHz steps) or ± 0.4 kHz (± 0.1 kHz) (for 12.5 kHz steps) deviation.
- Set the transceiver to CH 2 (band center), then key the transmitter, and confirm that the deviation is ± 0.6 kHz \sim ± 0.9 kHz (for 25 kHz steps) or ± 0.35 kHz \sim ± 0.6 kHz (for 12.5 kHz steps).
- Press the “OK” box to lock in the new data.

STD Deviation

- Set the transceiver to CH 2 (band center).
- Inject a 1 kHz tone at -37 dBm to the **MIC** jack.

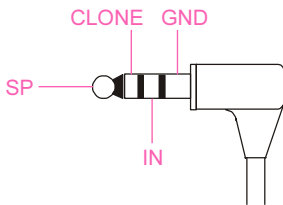

- To adjustment, click the left mouse button on the “MIC Sensitivity” box, then press the [ENTER] key to open the pop-up window.
- Use the [←] or [→] arrow keys so that the deviation meter reading is ± 3.0 kHz (± 0.1 kHz) (for 25 kHz steps) or ± 1.5 kHz (± 0.1 kHz) (for 12.5 kHz steps) deviation.
- Press the “OK” box to lock in the new data.

DTMF Deviation

- Set the transceiver to CH 2 (band center).
- To adjustment, click the left mouse button on the “DTMF Deviation” box, then press the [ENTER] key to open the pop-up window.
- Use the [←] or [→] arrow keys so that the deviation meter reading is ± 3.0 kHz (± 0.1 kHz) (for 25 kHz steps) or ± 1.5 kHz (± 0.1 kHz) (for 12.5 kHz steps) deviation.
- Press the “OK” box to lock in the new data.

DCS Deviation

- Set the transceiver to CH 2 (band center).
- To adjustment, click the left mouse button on the “DCS Modulation” box, then press the [ENTER] key to open the pop-up window.
- Use the [←] or [→] arrow keys so that the deviation meter reading is ± 0.7 kHz (± 0.1 kHz) (for 25 kHz steps) or ± 0.45 kHz (± 0.1 kHz) (for 12.5 kHz steps) deviation.
- Press the “OK” box to lock in the new data.

Sensitivity

- Set the transceiver to CH 3 (high band edge).
- Tune the RF signal generator to the same frequency as the transceiver's, then set the generator output level to 40 dB μ with ± 3.0 kHz deviation @ 1 kHz tone modulation.
- To adjustment, click the left mouse button on the “RX Sensitivity” box, then press the [ENTER] key to open the pop-up window.
- Use the [←] or [→] arrow keys to tune for best sensitivity; ultimately, the radio should be aligned so that the RF signal generator output level is -6 dB μ EMF (0.25 μ V) or less for 12 dB SINAD.
- Press the “OK” box to lock in the new data.

This completes the internal alignment routine. To save all settings and exit, press the “OK” box.

Circuit Diagram

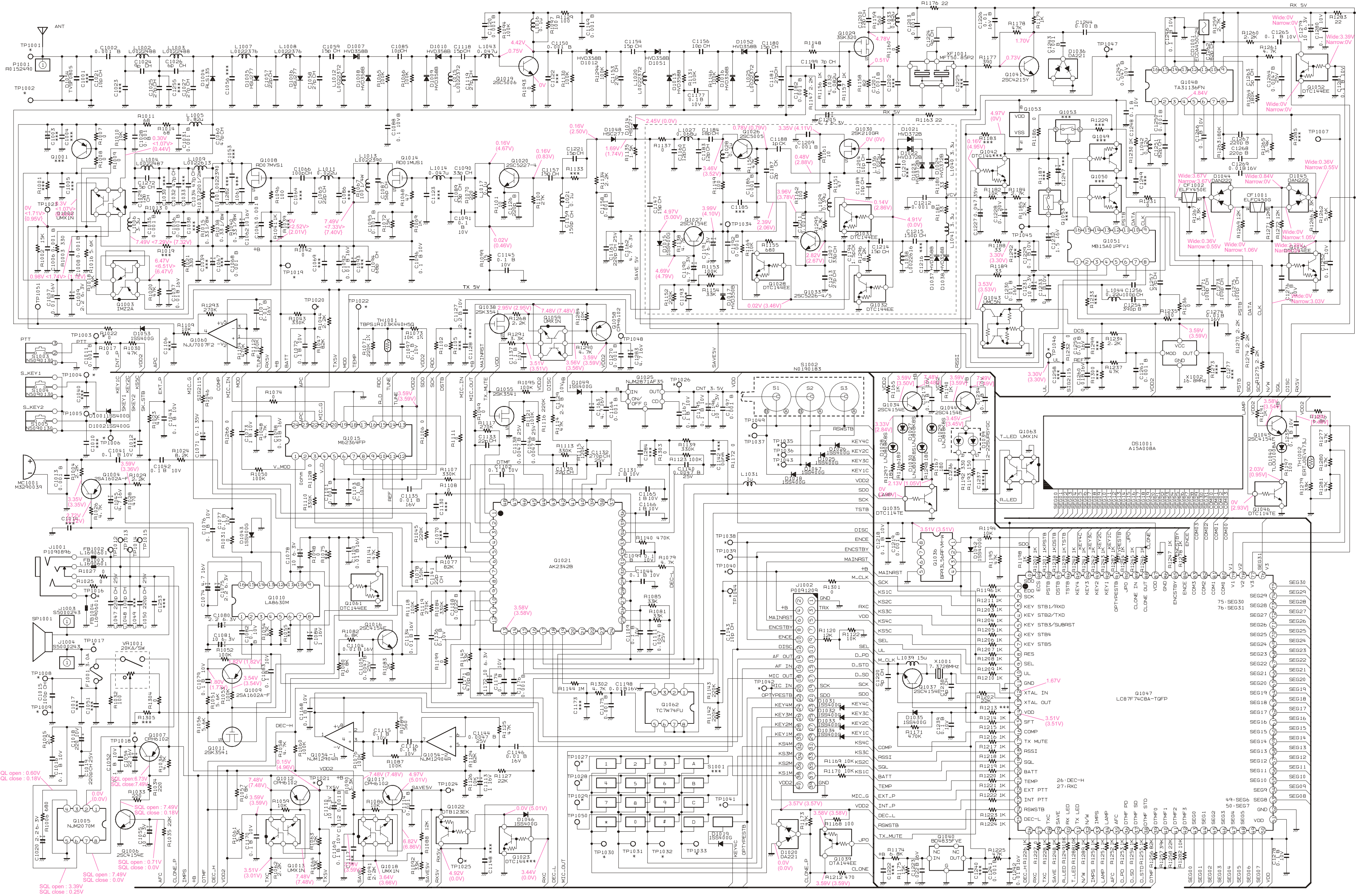

RX : XX
 TX : (XX)
 TX HIGH : <XX>
 TX LOW : [XX]
 LED on : [XX]

Note:

Parts Layout

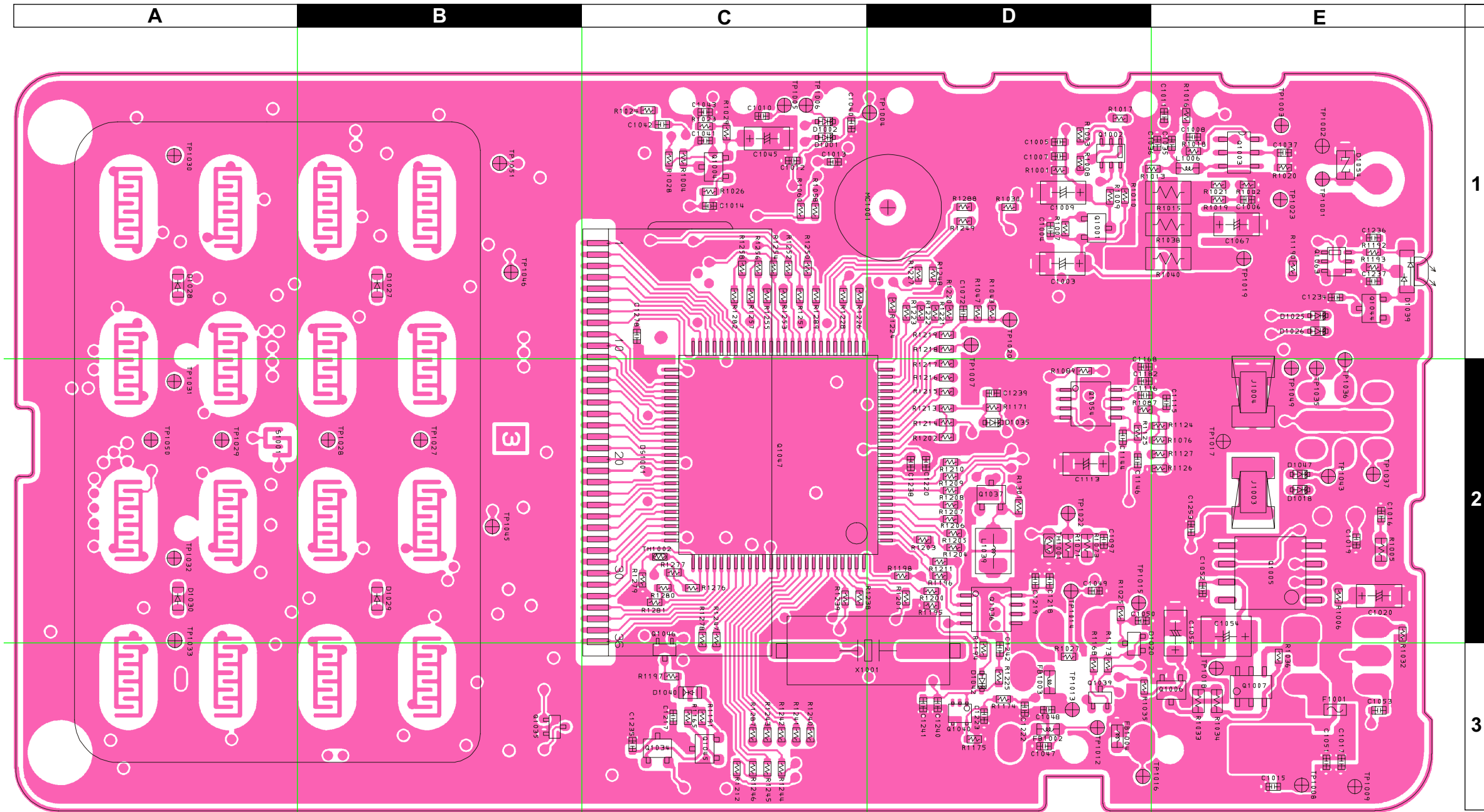

Side A

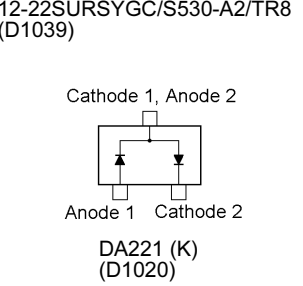
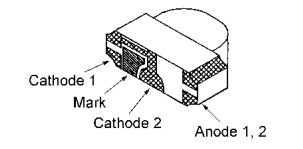
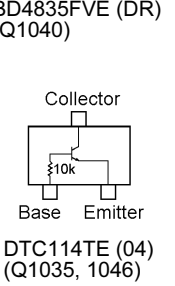
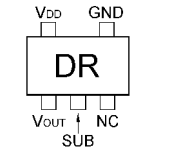
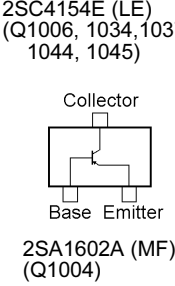
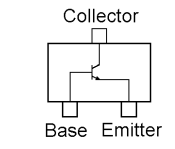
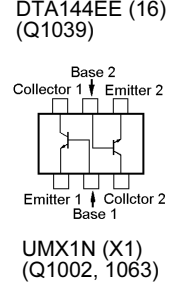
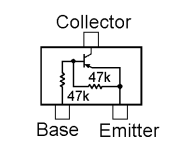
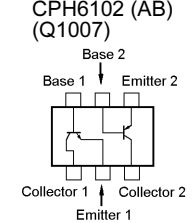
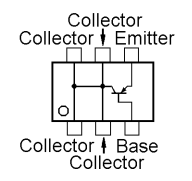
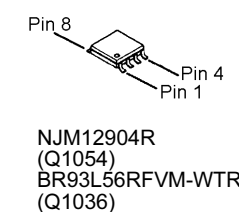
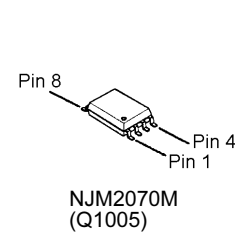
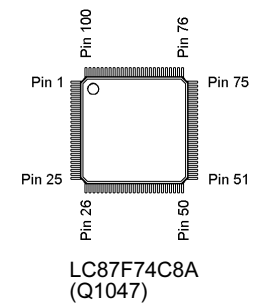

Parts Layout

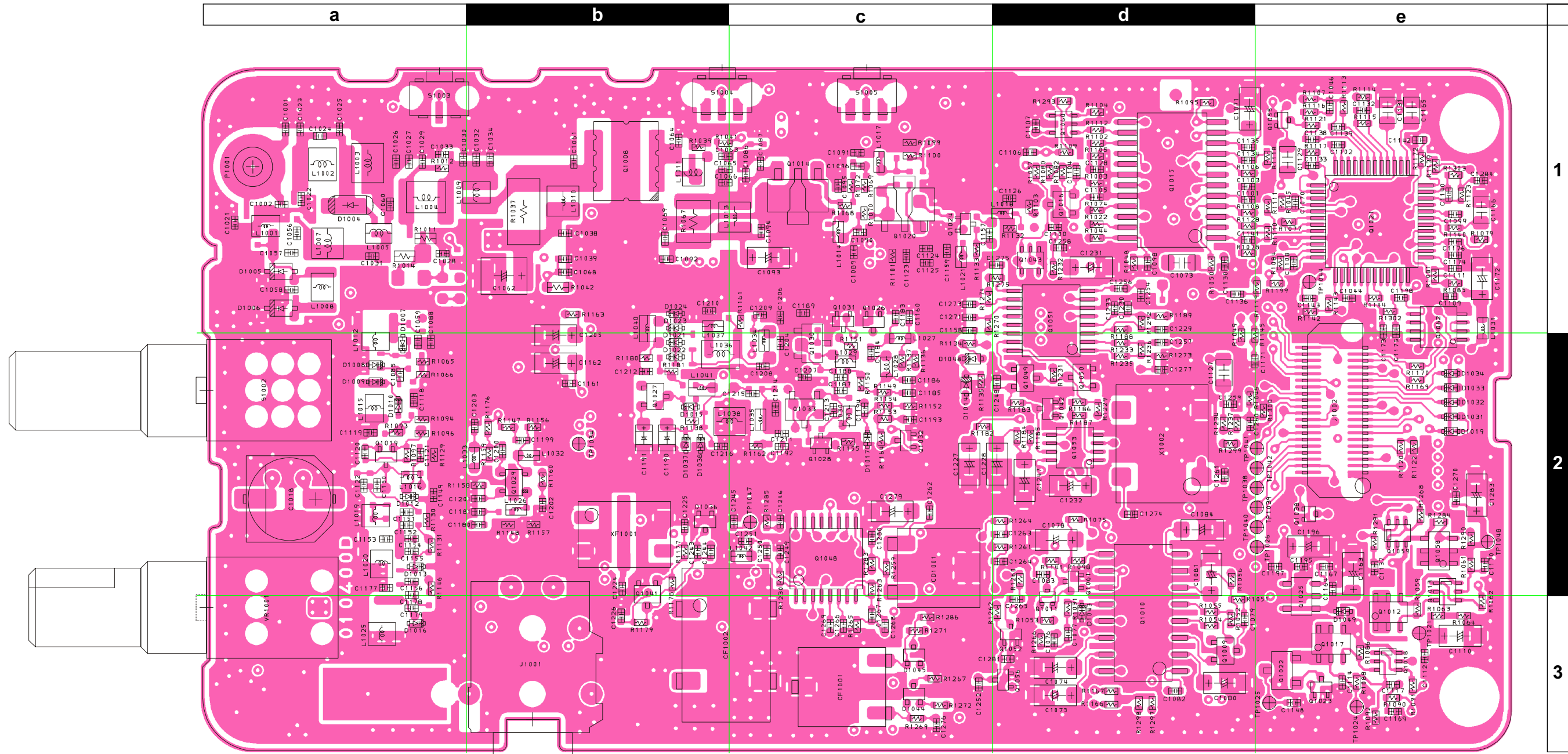

1
2
3

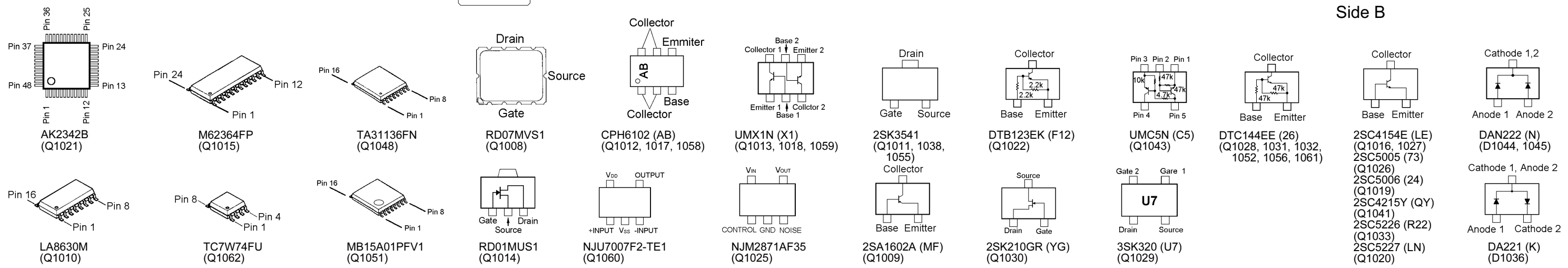

Parts List

REF.	DESCRIPTION	VALUE	V/W	TOL.	MFR'S DESIG	VXSTD P/N	VERS.	LOT.	SIDE	LAY ADR
PCB with Components						CB2541001	LCD ON			
						CB2541002	LCD OFF			
Printed Circuit Board						FR010400D			1-	
C 1002	CHIP CAP.	0.001uF	50V	B	GRM36B102K50PT	K22178809		1-	B	a1
C 1006	CHIP CAP.	0.001uF	50V	B	GRM36B102K50PT	K22178809		1-	A	E1
C 1007	CHIP CAP.	0.01uF	16V	B	GRM36B103K16PT	K22128804		1-	A	D1
C 1008	CHIP CAP.	0.001uF	50V	B	GRM36B102K50PT	K22178809		1-	A	E1
C 1009	CHIP TA.CAP.	2.2uF	6.3V		TESVA0J225M1-8R	K78080009		1-	A	D1
C 1011	CHIP CAP.	0.001uF	50V	B	GRM36B102K50PT	K22178809		1-	A	E1
C 1013	CHIP CAP.	0.001uF	50V	B	GRM36B102K50PT	K22178809		1-	A	C1
C 1015	CHIP CAP.	100pF	50V	CH	GRM36CH101J50PT	K22178236		1-	A	E3
C 1016	CHIP CAP.	0.1uF	10V	B	GRM36B104K10PT	K22108802		1-	A	E2
C 1018	AL.ELECTRO.CAP.	220uF	10V		EEE1AA221XP	K48100007		1-	B	a2
C 1019	CHIP CAP.	220pF	25V	CH	GRM36CH221J25PT	K22148203		1-	A	E2
C 1020	CHIP TA.CAP.	2.2uF	6.3V		TESVA0J225M1-8R	K78080009		1-	A	E2
C 1021	CHIP CAP.	10pF	50V	CH	GRM36CH100D50PT	K22178212		1-	B	a1
C 1024	CHIP CAP.	9pF	50V	CH	GRM36CH090D50PT	K22178211		1-	B	a1
C 1025	CHIP CAP.	27pF	50V	CH	GRM36CH270J50PT	K22178222		1-	B	a1
C 1026	CHIP CAP.	6pF	50V	CH	GRM36CH060D50PT	K22178208		1-	B	a1
C 1027	CHIP CAP.	27pF	50V	CH	GRM36CH270J50PT	K22178222		1-	B	a1
C 1028	CHIP CAP.	0.001uF	50V	B	GRM36B102K50PT	K22178809		1-	B	a1
C 1029	CHIP CAP.	15pF	50V	CH	GRM36CH150J50PT	K22178216		1	B	a1
C 1029	CHIP CAP.	12pF	50V	CH	GRM36CH120J50PT	K22178214		2-	B	a1
C 1031	CHIP CAP.	0.001uF	50V	B	GRM36B102K50PT	K22178809		1-	B	a1
C 1032	CHIP CAP.	47pF	50V	CH	GRM36CH470J50PT	K22178228		1-	B	b1
C 1034	CHIP CAP.	47pF	50V	CH	GRM36CH470J50PT	K22178228		1-	B	b1
C 1035	CHIP CAP.	0.001uF	50V	B	GRM36B102K50PT	K22178809		1-	A	E1
C 1036	CHIP CAP.	0.001uF	50V	B	GRM36B102K50PT	K22178809		1-	A	E1
C 1037	CHIP CAP.	0.01uF	16V	B	GRM36B103K16PT	K22128804		1-	A	E1
C 1041	CHIP CAP.	0.1uF	10V	B	GRM36B104K10PT	K22108802		1-	A	C1
C 1042	CHIP CAP.	0.1uF	10V	B	GRM36B104K10PT	K22108802		1-	A	C1
C 1043	CHIP CAP.	0.1uF	10V	B	GRM36B104K10PT	K22108802		1-	A	C1
C 1044	CHIP CAP.	0.1uF	10V	B	GRM36B104K10PT	K22108802		1-	B	e1
C 1045	CHIP TA.CAP.	4.7uF	16V		TEMSVA1C475M-8R	K78120031		1-	A	C1
C 1046	CHIP CAP.	0.0047uF	25V	B	GRM36B472K25PT	K22148830		1-	B	e1
C 1047	CHIP CAP.	220pF	25V	CH	GRM36CH221J25PT	K22148203		1-	A	D3
C 1048	CHIP CAP.	100pF	50V	CH	GRM36CH101J50PT	K22178236		1-	A	D3
C 1050	CHIP CAP.	220pF	25V	CH	GRM36CH221J25PT	K22148203		1-	A	D2
C 1052	CHIP CAP.	0.1uF	10V	B	GRM36B104K10PT	K22108802		1-	A	E2
C 1054	CHIP TA.CAP.	22uF	16V		TEMSVB21C226M-8R	K78120028		1-	A	E2
C 1055	CHIP TA.CAP.	10uF	6.3V		TEMSVA0J106M-8R	K78080027		1-	A	E2
C 1057	CHIP CAP.	22pF	50V	CH	GRM36CH220J50PT	K22178220		1-	B	a1
C 1058	CHIP CAP.	27pF	50V	CH	GRM36CH270J50PT	K22178222		1-	B	a1
C 1059	CHIP CAP.	15pF	50V	CH	GRM36CH150J50PT	K22178216		1-	B	a1
C 1060	CHIP CAP.	47pF	50V	CH	GRM36CH470J50PT	K22178228		1-	B	a1
C 1062	CHIP TA.CAP.	10uF	16V		TEMSVB21C106M-8R	K78120025		1-	B	b1
C 1063	CHIP CAP.	0.001uF	50V	B	GRM36B102K50PT	K22178809		1-	B	c1
C 1065	CHIP CAP.	22pF	50V	CH	GRM36CH220J50PT	K22178220		1-	B	b1
C 1066	CHIP CAP.	100pF	50V	CH	GRM36CH101J50PT	K22178236		1-	B	b1
C 1068	CHIP CAP.	0.001uF	50V	B	GRM36B102K50PT	K22178809		1-	B	b1
C 1071	CHIP TA.CAP.	0.1uF	35V		TESVA1V104M1-8R	K78160025		1-	B	d1
C 1072	CHIP CAP.	0.1uF	10V	B	GRM36B104K10PT	K22108802		1-	A	D1
C 1073	CHIP CAP.	1uF	10V	B	ECJ2FB1A105K	K22100806		1-	B	d1
C 1074	CHIP TA.CAP.	4.7uF	16V		TEMSVA1C475M-8R	K78120031		1-	B	d3
C 1075	CHIP TA.CAP.	2.2uF	6.3V		TESVA0J225M1-8R	K78080009		1-	B	d3
C 1076	CHIP CAP.	0.1uF	10V	B	GRM36B104K10PT	K22108802		1-	B	d3
C 1077	CHIP CAP.	0.1uF	10V	B	GRM36B104K10PT	K22108802		1-	B	d3
C 1078	CHIP TA.CAP.	10uF	6.3V		TEMSVA0J106M-8R	K78080027		1-	B	d2
C 1079	CHIP CAP.	0.1uF	10V	B	GRM36B104K10PT	K22108802		1-	B	d3
C 1080	CHIP TA.CAP.	2.2uF	6.3V		TESVA0J225M1-8R	K78080009		1-	B	d3
C 1081	CHIP TA.CAP.	10uF	6.3V		TEMSVA0J106M-8R	K78080027		1-	B	d2
C 1082	CHIP CAP.	0.1uF	10V	B	GRM36B104K10PT	K22108802		1-	B	d3
C 1083	CHIP CAP.	0.1uF	10V	B	GRM36B104K10PT	K22108802		1-	B	d2
C 1084	CHIP TA.CAP.	1uF	16V		TESVA1C105M1-8R	K78120009		1-	B	d2
C 1085	CHIP CAP.	10pF	50V	CH	GRM36CH100D50PT	K22178212		1-	B	a2
C 1087	CHIP CAP.	56pF	50V	CH	GRM36CH560J50PT	K22178230		1-	B	c1
C 1088	CHIP CAP.	0.01uF	16V	B	GRM36B103K16PT	K22128804		1-	B	a2

MAIN Unit

REF.	DESCRIPTION	VALUE	V/W	TOL.	MFR'S DESIG	VXSTD P/N	VERS.	LOT.	SIDE	LAY ADR
C 1089	CHIP CAP.	33pF	50V	CH	GRM36CH330J50PT	K22178224		1-	B	c1
C 1090	CHIP CAP.	33pF	50V	CH	GRM36CH330J50PT	K22178224		1-	B	c1
C 1091	CHIP CAP.	0.1uF	10V	B	GRM36B104K10PT	K22108802		1-	B	c1
C 1092	CHIP CAP.	0.01uF	16V	B	GRM36B103K16PT	K22128804		1-	B	b1
C 1094	CHIP CAP.	68pF	50V	CH	GRM36CH680J50PT	K22178232		1-	B	c1
C 1095	CHIP CAP.	0.001uF	50V	B	GRM36B102K50PT	K22178809		1-	B	c1
C 1096	CHIP CAP.	0.1uF	10V	B	GRM36B104K10PT	K22108802		1-	B	c1
C 1097	CHIP CAP.	0.1uF	10V	B	GRM36B104K10PT	K22108802		1-	A	D2
C 1098	CHIP CAP.	0.01uF	16V	B	GRM36B103K16PT	K22128804		1-	B	d1
C 1099	CHIP CAP.	0.1uF	10V	B	GRM36B104K10PT	K22108802		1-	B	e1
C 1100	CHIP CAP.	0.01uF	16V	B	GRM36B103K16PT	K22128804		1-	B	d1
C 1101	CHIP CAP.	0.001uF	50V	B	GRM36B102K50PT	K22178809		1-	B	d1
C 1102	CHIP CAP.	0.1uF	10V	B	GRM36B104K10PT	K22108802		1-	B	e1
C 1103	CHIP CAP.	0.1uF	10V	B	GRM36B104K10PT	K22108802		1-	B	d1
C 1104	CHIP CAP.	0.01uF	16V	B	GRM36B103K16PT	K22128804		1-	B	d1
C 1105	CHIP CAP.	0.0047uF	25V	B	GRM36B472K25PT	K22148830		1-	B	d1
C 1107	CHIP CAP.	0.01uF	16V	B	GRM36B103K16PT	K22128804		1-	B	d1
C 1108	CHIP CAP.	0.0022uF	50V	B	GRM36B222K50PT	K22178813		1-	B	e1
C 1109	CHIP CAP.	0.1uF	10V	B	GRM36B104K10PT	K22108802		1-	B	e1
C 1110	CHIP TA.CAP.	10uF	6.3V		TEMSVA0J106M-8R	K78080027		1-	B	e3
C 1111	CHIP CAP.	0.0047uF	25V	B	GRM36B472K25PT	K22148830		1-	B	e1
C 1112	CHIP CAP.	0.001uF	50V	B	GRM36B102K50PT	K22178809		1-	B	e3
C 1113	CHIP TA.CAP.	1uF	16V		TEMSVA21C105M-8R	K78120024		1-	A	D2
C 1114	CHIP CAP.	0.001uF	50V	B	GRM36B102K50PT	K22178809		1-	B	e3
C 1115	CHIP CAP.	0.1uF	10V	B	GRM36B104K10PT	K22108802		1-	A	E2
C 1116	CHIP CAP.	0.1uF	10V	B	GRM36B104K10PT	K22108802		1-	A	D2
C 1118	CHIP CAP.	15pF	50V	CH	GRM36CH150J50PT	K22178216		1-	B	a2
C 1119	CHIP CAP.	27pF	50V	CH	GRM36CH270J50PT	K22178222		1-	B	a2
C 1120	CHIP CAP.	0.001uF	50V	B	GRM36B102K50PT	K22178809		1-	B	a2
C 1126	CHIP CAP.	220pF	50V	B	GRM36B221K50PT	K22178801		1-	B	c1
C 1127	CHIP CAP.	2.2uF	10V	B	ECJ2FB1A225K	K22100807		1-	B	d2
C 1129	CHIP CAP.	2.2uF	10V	B	ECJ2FB1A225K	K22100807		1-	B	e1
C 1131	CHIP CAP.	1uF	10V	B	ECJ2FB1A105K	K22100806		1-	B	e1
C 1132	CHIP CAP.	150pF	50V	CH	GRM36CH151J50PT	K22178240		1	B	e1
C 1132	CHIP CAP.	270pF	25V	CH	GRM36CH271J25PT	K22148248		2-	B	e1
C 1133	CHIP CAP.	47pF	50V	CH	GRM36CH470J50PT	K22178228		1	B	e1
C 1133	CHIP CAP.	22pF	50V	CH	GRM36CH220J50PT	K22178220		2-	B	e1
C 1134	CHIP CAP.	0.01uF	16V	B	GRM36B103K16PT	K22128804		1-	B	d1
C 1135	CHIP CAP.	0.01uF	16V	B	GRM36B103K16PT	K22128804		1-	B	d1
C 1136	CHIP CAP.	0.1uF	10V	B	GRM36B104K10PT	K22108802		1-	B	d1
C 1137	CHIP CAP.	0.1uF	10V	B	GRM36B104K10PT	K22108802		1-	B	e2
C 1138	CHIP CAP.	0.0047uF	25V	B	GRM36B472K25PT	K22148830		1-	B	e1
C 1139	CHIP CAP.	22pF	50V	CH	GRM36CH220J50PT	K22178220		1-	B	e1
C 1140	CHIP CAP.	0.0047uF	25V	B	GRM36B472K25PT	K22148830		1-	B	e1
C 1141	CHIP CAP.	47pF	50V	CH	GRM36CH470J50PT	K22178228		1	B	d1
C 1141	CHIP CAP.	22pF	50V	CH	GRM36CH220J50PT	K22178220		2-	B	d1
C 1143	CHIP CAP.	10pF	50V	CH	GRM36CH100D50PT	K22178212		1-	B	e1
C 1144	CHIP CAP.	0.0047uF	25V	B	GRM36B472K25PT	K22148830		1-	A	D2
C 1145	CHIP CAP.	0.1uF	10V	B	GRM36B104K10PT	K22108802		1-	B	c1
C 1146	CHIP CAP.	0.01uF	16V	B	GRM36B103K16PT	K22128804		1-	A	D2
C 1147	CHIP CAP.	15pF	50V	CH	GRM36CH150J50PT	K22178216		1-	B	c2
C 1149	CHIP CAP.	0.001uF	50V	B	GRM36B102K50PT	K22178809		1-	B	a2
C 1150	CHIP CAP.	0.001uF	50V	B	GRM36B102K50PT	K22178809		1-	B	a2
C 1153	CHIP CAP.	27pF	50V	CH	GRM36CH270J50PT	K22178222		1-	B	a2
C 1154	CHIP CAP.	15pF	50V	CH	GRM36CH150J50PT	K22178216		1-	B	a2
C 1156	CHIP CAP.	10pF	50V	CH	GRM36CH100D50PT	K22178212		1-	B	a2
C 1157	CHIP CAP.	15pF	50V	CH	GRM36CH150J50PT	K22178216		1-	B	c1
C 1158	CHIP CAP.	0.001uF	50V	B	GRM36B102K50PT	K22178809		1-	B	c1
C 1159	CHIP CAP.	150pF	50V	CH	GRM36CH151J50PT	K22178240		1-	B	c1
C 1160	CHIP CAP.	12pF	50V	CH	GRM36CH120J50PT	K22178214		1-	B	c1
C 1161	CHIP CAP.	220pF	25V	CH	GRM36CH221J25PT	K22148203		1-	B	b2
C 1162	CHIP TA.CAP.	4.7uF	6.3V		TEMSVA0J475M-8R	K78080017		1-	B	b2
C 1163	CHIP TA.CAP.	4.7uF	16V		TEMSVA1C475M-8R	K78120031		1-	B	e2
C 1164	CHIP CAP.	0.001uF	50V	B	GRM36B102K50PT	K22178809		1-	B	e2
C 1165	CHIP CAP.	1uF	10V	B	ECJ2FB1A105K	K22100806		1-	B	e1
C 1166	CHIP CAP.	1uF	10V	B	ECJ2FB1A105K	K22100806		1-	B	e1
C 1167	CHIP CAP.	0.1uF	10V	B	GRM36B104K10PT	K22108802		1-	B	e2

REF.	DESCRIPTION	VALUE	V/W	TOL.	MFR'S DESIG	VXSTD P/N	VERS.	LOT.	SIDE	LAY ADR
C 1168	CHIP CAP.	0.1uF	10V	B	GRM36B104K10PT	K22108802		1-	A	D2
C 1169	CHIP CAP.	0.1uF	10V	B	GRM36B104K10PT	K22108802		1-	B	e3
C 1170	CHIP CAP.	0.1uF	10V	B	GRM36B104K10PT	K22108802		1-	B	e2
C 1171	CHIP CAP.	470pF	50V	B	GRM36B471K50PT	K22178805		1-	B	d2
C 1172	CHIP TA.CAP.	10uF	6.3V		TEMSVA0J106M-8R	K78080027		1-	B	e1
C 1174	CHIP CAP.	0.1uF	10V	B	GRM36B104K10PT	K22108802		1-	B	e1
C 1175	CHIP CAP.	0.001uF	50V	B	GRM36B102K50PT	K22178809		1-	B	e1
C 1176	CHIP CAP.	0.001uF	50V	B	GRM36B102K50PT	K22178809		1-	B	e1
C 1177	CHIP CAP.	0.001uF	50V	B	GRM36B102K50PT	K22178809		1-	B	a2
C 1180	CHIP CAP.	15pF	50V	CH	GRM36CH150J50PT	K22178216		1-	B	b2
C 1181	CHIP CAP.	27pF	50V	CH	GRM36CH270J50PT	K22178222		1-	B	b2
C 1182	CHIP CAP.	0.001uF	50V	B	GRM36B102K50PT	K22178809		1-	A	D2
C 1183	CHIP CAP.	12pF	50V	CH	GRM36CH120J50PT	K22178214		1-	B	c1
C 1184	CHIP CAP.	18pF	50V	CH	GRM36CH180J50PT	K22178218		1-	B	c2
C 1186	CHIP CAP.	0.001uF	50V	B	GRM36B102K50PT	K22178809		1-	B	c2
C 1187	CHIP CAP.	2pF	50V	CK	GRM36CK020B50PT	K22178289		1-	B	c2
C 1188	CHIP CAP.	1pF	50V	CK	GRM36CK010B50PT	K22178287		1-	B	c2
C 1189	CHIP CAP.	10pF	50V	CH	GRM36CH100B50PT	K22178297		1-	B	c1
C 1190	CHIP TA.CAP.	4.7uF	6.3V		TESVSP0J475M-8R	K78080053		1-	B	b2
C 1191	CHIP TA.CAP.	4.7uF	6.3V		TESVSP0J475M-8R	K78080053		1-	B	b2
C 1192	CHIP CAP.	0.001uF	50V	B	GRM36B102K50PT	K22178809		1-	B	b2
C 1194	CHIP CAP.	1.5pF	50V	CK	GRM36CK1R5B50PT	K22178288		1-	B	c2
C 1195	CHIP CAP.	0.1uF	10V	B	GRM36B104K10PT	K22108802		1-	B	e2
C 1196	CHIP TA.CAP.	10uF	6.3V		TEMSVA0J106M-8R	K78080027		1-	B	e2
C 1197	CHIP CAP.	0.001uF	50V	B	GRM36B102K50PT	K22178809		1-	B	e2
C 1198	CHIP CAP.	0.01uF	16V	B	GRM36B103K16PT	K22128804		1-	B	e1
C 1199	CHIP CAP.	7pF	50V	CH	GRM36CH070D50PT	K22178209		1-	B	b2
C 1200	CHIP CAP.	12pF	50V	CH	GRM36CH120J50PT	K22178214		1-	B	b2
C 1201	CHIP CAP.	0.001uF	50V	B	GRM36B102K50PT	K22178809		1-	B	b2
C 1203	CHIP CAP.	0.001uF	50V	B	GRM36B102K50PT	K22178809		1-	B	b2
C 1204	CHIP CAP.	10pF	50V	CH	GRM36CH100B50PT	K22178297		1-	B	c2
C 1205	CHIP TA.CAP.	4.7uF	6.3V		TEMSVA0J475M-8R	K78080017		1-	B	b2
C 1207	CHIP CAP.	33pF	50V	CH	GRM36CH330J50PT	K22178224		1-	B	c2
C 1209	CHIP CAP.	0.001uF	50V	B	GRM36B102K50PT	K22178809		1-	B	c1
C 1211	CHIP CAP.	0.001uF	50V	B	GRM36B102K50PT	K22178809		1-	B	c2
C 1212	CHIP CAP.	0.001uF	50V	B	GRM36B102K50PT	K22178809		1-	B	b2
C 1213	CHIP CAP.	27pF	50V	CH	GRM36CH270J50PT	K22178222		1-	B	c2
C 1214	CHIP CAP.	15pF	50V	CH	GRM36CH150J50PT	K22178216		1-	B	c2
C 1215	CHIP CAP.	150pF	50V	CH	GRM36CH151J50PT	K22178240		1-	B	c2
C 1217	CHIP CAP.	0.1uF	10V	B	GRM36B104K10PT	K22108802	W/LCD	1-	A	C3
C 1218	CHIP CAP.	0.1uF	10V	B	GRM36B104K10PT	K22108802		1-	A	D2
C 1219	CHIP CAP.	0.001uF	50V	B	GRM36B102K50PT	K22178809		1-	A	D2
C 1220	CHIP CAP.	9pF	50V	CH	GRM36CH090D50PT	K22178211		1-	A	D2
C 1221	CHIP CAP.	15pF	50V	CH	GRM36CH150J50PT	K22178216		1-	B	c1
C 1223	CHIP CAP.	0.022uF	16V	B	GRM36B223K16PT	K22128806		1-	A	D3
C 1224	CHIP CAP.	9pF	50V	CH	GRM36CH090D50PT	K22178211		1-	B	b2
C 1226	CHIP CAP.	0.01uF	16V	B	GRM36B103K16PT	K22128804		1-	B	b3
C 1227	CHIP TA.CAP.	0.047uF	35V		TESVA1V473M1-8R	K78160023		1-	B	c2
C 1228	CHIP TA.CAP.	0.1uF	20V		TEMSVA21D104M-8R	K78130020		1-	B	d2
C 1229	CHIP CAP.	0.1uF	10V	B	GRM36B104K10PT	K22108802		1-	B	d1
C 1230	CHIP CAP.	0.01uF	16V	B	GRM36B103K16PT	K22128804		1-	B	d1
C 1231	CHIP TA.CAP.	10uF	6.3V		TEMSVA0J106M-8R	K78080027		1-	B	d1
C 1232	CHIP TA.CAP.	1.5uF	16V		TESVA1C155M1-8R	K78120020		1-	B	d2
C 1233	CHIP CAP.	0.1uF	10V	B	GRM36B104K10PT	K22108802		1-	B	d1
C 1234	CHIP CAP.	0.1uF	10V	B	GRM36B104K10PT	K22108802		1-	A	E1
C 1235	CHIP CAP.	0.1uF	10V	B	GRM36B104K10PT	K22108802	W/LCD	1-	A	C3
C 1238	CHIP CAP.	9pF	50V	CH	GRM36CH090D50PT	K22178211		1-	A	D2
C 1239	CHIP CAP.	0.1uF	10V	B	GRM36B104K10PT	K22108802		1-	A	D2
C 1241	CHIP CAP.	0.001uF	50V	B	GRM36B102K50PT	K22178809		1-	A	D3
C 1242	CHIP CAP.	0.01uF	16V	B	GRM36B103K16PT	K22128804		1-	A	D3
C 1243	CHIP CAP.	0.001uF	50V	B	GRM36B102K50PT	K22178809		1-	B	b2
C 1244	CHIP CAP.	0.001uF	50V	B	GRM36B102K50PT	K22178809		1-	B	b2
C 1245	CHIP CAP.	0.047uF	10V	B	GRM36B473K10PT	K22108801		1-	B	c2
C 1246	CHIP CAP.	0.1uF	10V	B	GRM36B104K10PT	K22108802		1-	B	c2
C 1248	CHIP CAP.	0.1uF	10V	B	GRM36B104K10PT	K22108802		1-	B	d2
C 1250	CHIP CAP.	0.001uF	50V	B	GRM36B102K50PT	K22178809		1-	B	c2
C 1251	CHIP CAP.	82pF	50V	CH	GRM36CH820J50PT	K22178234		1-	B	c2

MAIN Unit

REF.	DESCRIPTION	VALUE	V/W	TOL.	MFR'S DESIG	VXSTD P/N	VERS.	LOT.	SIDE	LAY ADR
C 1252	CHIP CAP.	0.1uF	10V	B	GRM36B104K10PT	K22108802		1-	B	c3
C 1254	CHIP CAP.	390pF	50V	B	GRM36B391K50PT	K22178804		1-	B	d1
C 1256	CHIP CAP.	100pF	50V	CH	GRM36CH101J50PT	K22178236		1-	B	d1
C 1257	CHIP CAP.	27pF	50V	CH	GRM36CH270J50PT	K22178222		1-	B	d2
C 1259	CHIP CAP.	0.01uF	16V	B	GRM36B103K16PT	K22128804		1-	B	d2
C 1260	CHIP CAP.	0.01uF	16V	B	GRM36B103K16PT	K22128804		1-	B	d2
C 1261	CHIP CAP.	0.001uF	50V	B	GRM36B102K50PT	K22178809		1-	B	d2
C 1262	CHIP CAP.	82pF	50V	CH	GRM36CH820J50PT	K22178234		1-	B	c2
C 1263	CHIP CAP.	5pF	50V	CH	GRM36CH050C50PT	K22178207		1-	B	d2
C 1264	CHIP CAP.	0.0047uF	25V	B	GRM36B472K25PT	K22148830		1-	B	d2
C 1265	CHIP CAP.	0.1uF	10V	B	GRM36B104K10PT	K22108802		1-	B	d3
C 1266	CHIP CAP.	0.1uF	10V	B	GRM36B104K10PT	K22108802		1-	B	c3
C 1267	CHIP CAP.	220pF	50V	B	GRM36B221K50PT	K22178801		1-	B	c3
C 1268	CHIP CAP.	220pF	50V	B	GRM36B221K50PT	K22178801		1-	B	c3
C 1269	CHIP CAP.	0.01uF	16V	B	GRM36B103K16PT	K22128804		1-	B	c3
C 1270	CHIP CAP.	0.001uF	50V	B	GRM36B102K50PT	K22178809		1-	B	e2
C 1271	CHIP CAP.	100pF	50V	CH	GRM36CH101J50PT	K22178236		1-	B	c1
C 1272	CHIP CAP.	5pF	50V	CH	GRM36CH050C50PT	K22178207		2-		
C 1273	CHIP CAP.	100pF	50V	CH	GRM36CH101J50PT	K22178236		1-	B	c1
C 1274	CHIP CAP.	0.01uF	16V	B	GRM36B103K16PT	K22128804		1-	B	d2
C 1275	CHIP CAP.	100pF	50V	CH	GRM36CH101J50PT	K22178236		1-	B	d1
C 1276	CHIP CAP.	0.1uF	10V	B	GRM36B104K10PT	K22108802		1-	B	c3
C 1278	CHIP CAP.	0.1uF	10V	B	GRM36B104K10PT	K22108802		1-	A	C1
C 1279	CHIP TA.CAP.	10uF	6.3V		TEMSVA0J106M-8R	K78080027		1-	B	c2
C 1280	CHIP CAP.	0.1uF	10V	B	GRM36B104K10PT	K22108802		1-	B	c2
C 1281	CHIP CAP.	0.1uF	10V	B	GRM36B104K10PT	K22108802		1-	B	d3
C 1283	CHIP TA.CAP.	4.7uF	16V		TEMSVA1C475M-8R	K78120031		1-	B	e2
CD1001	CERAMIC DISC				ECDA450C24	H7901460		1-	B	c2
CF1001	CERAMIC FILTER				ELFC450G	H3900538		1-	B	c3
CF1002	CERAMIC FILTER				ELFY450E	H3900549		1-	B	b3
D 1001	DIODE				1SS400G T2R	G2070934		1-	A	C1
D 1002	DIODE				1SS400G T2R	G2070934		1-	A	C1
D 1004	DIODE				RLS135 TE-11	G2070128		1-	B	a1
D 1005	DIODE				HSU277TRF	G2070118		1-	B	a1
D 1006	DIODE				HSU277TRF	G2070118		1-	B	a1
D 1007	DIODE				HVD358B	G2070950		1-	B	a2
D 1008	DIODE				HVD358B	G2070950		1-	B	a2
D 1009	DIODE				HVD358B	G2070950		1-	B	a2
D 1010	DIODE				HVD358B	G2070950		1-	B	a2
D 1012	DIODE				HVD358B	G2070950		1-	B	a2
D 1013	DIODE				HVD358B	G2070950		1-	B	a2
D 1014	DIODE				HSC277TRF	G2070584		1-	B	c2
D 1015	DIODE				1SS400G T2R	G2070934		1-	B	b2
D 1016	DIODE				HVD358B	G2070950		1-	B	a2
D 1017	DIODE				HVD350B	G2070946		1-	B	c2
D 1018	DIODE				1SS400G T2R	G2070934		1-	A	E2
D 1019	DIODE				1SS400G T2R	G2070934		1-	B	e2
D 1020	DIODE				DA221 TL	G2070178		1-	A	D3
D 1021	DIODE				HVD372B KRF	G2070966		1-	B	b2
D 1022	DIODE				HVD372B KRF	G2070966		1-	B	b2
D 1023	DIODE				HVD372B KRF	G2070966		1-	B	b1
D 1024	DIODE				HVD372B KRF	G2070966		1-	B	b1
D 1025	DIODE				1SS400G T2R	G2070934		1-	A	E1
D 1026	DIODE				1SS400G T2R	G2070934		1-	A	E1
D 1027	LED				LNJ808K8SRA	G2070790	W/LCD	1-	A	B1
D 1028	LED				LNJ808K8SRA	G2070790	W/LCD	1-	A	A1
D 1029	LED				LNJ808K8SRA	G2070790	W/LCD	1-	A	B2
D 1030	LED				LNJ808K8SRA	G2070790	W/LCD	1-	A	A2
D 1031	DIODE				1SS400G T2R	G2070934		1-	B	e2
D 1032	DIODE				1SS400G T2R	G2070934		1-	B	e2
D 1033	DIODE				1SS400G T2R	G2070934		1-	B	e2
D 1034	DIODE				1SS400G T2R	G2070934		1-	B	e2
D 1035	DIODE				1SS400G T2R	G2070934		1-	A	D2
D 1036	DIODE				DA221 TL	G2070178		1-	B	b2
D 1037	DIODE				HVD358B	G2070950		1-	B	b2
D 1038	DIODE				HVD358B	G2070950		1-	B	b2
D 1039	LED				12-22SURSYGC/S530-A2/TR8	G2070810		1-	A	E1

REF.	DESCRIPTION	VALUE	V/W	TOL.	MFR'S DESIG	VXSTD P/N	VERS.	LOT.	SIDE	LAY ADR
D 1040	LED				TLOU1008A(TAPE)	G2070958	W/LCD	1-	A	C3
D 1042	DIODE				1SS400G T2R	G2070934		1-	A	D3
D 1043	DIODE				1SS400G T2R	G2070934		1-	B	d3
D 1044	DIODE				DAN222 TL	G2070174		1-	B	c3
D 1045	DIODE				DAN222 TL	G2070174		1-	B	c3
D 1046	DIODE				1SS400G T2R	G2070934		1-		
D 1047	DIODE				1SS400G T2R	G2070934		1-	A	E2
D 1048	DIODE				HSC277TRF	G2070584		1-	B	c2
D 1049	DIODE				1SS400G T2R	G2070934		1-	B	e3
D 1051	DIODE				HVD358B	G2070950		1-	B	a2
D 1052	DIODE				HVD358B	G2070950		1-	B	a3
D 1053	DIODE				1SS400G T2R	G2070934		1-	B	d1
D 1054	SURGE ABSORBER				TVSF0805	Q9000807		1-	A	E1
DS1001	LCD				A15A008A	G6090156	W/LCD	1-	A	C2
F 1001	CHIP FUSE	3A			0434 003. 3.0A	Q0000107		1-	A	E3
FB1002	CHIP COI				BLM11P600SPT	L1690601		1-	A	D3
FB1003	CHIP COI				BLM11P600SPT	L1690601		1-	A	D3
FB1004	CHIP COI				BLM11P600SPT	L1690601		1-	A	D3
J 1001	CONNECTOR				HSJ1594-010055	P1090896		1-	B	b3
J 1002	CONNECTOR				AXK6S40535P	P0091209		1-	B	e2
J 1003	CONTACT				OG-503040	S5000243		1-	A	E2
J 1004	CONTACT				OG-503040	S5000243		1-	A	E2
L 1002	COIL				E2 0.5-2.0-6T-R	L0022488		1-	B	a1
L 1003	COIL				E2 0.5-2.0-6T-R	L0022488		1-	B	a1
L 1004	COIL				E2 0.5-2.0-5T-R	L0022487		1-	B	a1
L 1005	M.RFC	0.82uH			LK2125 R82K-T	L1690318		1-	B	a1
L 1006	M.RFC	3.3uH			LK1608 3R3K-T	L1690686		1-	A	E1
L 1007	COIL				E2 0.3-1.7-8T-L	L0022376		1-	B	a1
L 1008	COIL				E2 0.3-1.7-8T-L	L0022376		1-	B	a1
L 1009	COIL				E2 0.5-1.4-2.5T-L	L0022613		1-	B	b1
L 1010	COIL				E2 0.35-1.6-7T-L	L0022390		1-	B	b1
L 1011	M.RFC	0.022uH			HK2125 22NK-T	L1690381		1-	B	b1
L 1012	COIL				E2 0.3-1.7-7T-R	L0022372		1-	B	a1
L 1013	COIL				E2 0.35-1.6-7T-L	L0022390		1-	B	c1
L 1014	M.RFC	0.047uH			HK1608 47NJ-T	L1690524		1-	B	c1
L 1015	COIL				E2 0.3-1.7-7T-R	L0022372		1-	B	a2
L 1016	M.RFC	0.1uH			HK1608 R10J-T	L1690528		1-	B	a2
L 1017	M.RFC	0.056uH			HK1608 56NJ-T	L1690525		1	B	c1
L 1017	M.RFC	0.1uH			HK1608 R10J-T	L1690528		2-	B	c1
L 1020	COIL				E2 0.3-1.7-7T-R	L0022372		1-	B	a2
L 1021	M.RFC	0.1uH			HK1608 R10J-T	L1690528		1-	B	d1
L 1025	COIL				E2 0.3-1.7-7T-R	L0022372		1-	B	a3
L 1027	M.RFC	0.068uH			HK1608 68NJ-T	L1690526		1-	B	c2
L 1028	M.RFC	0.1uH			HK1608 R10J-T	L1690528		1-	B	c2
L 1029	M.RFC	0.39uH		5%	C1608CA-R39J	L1691219		1-	B	c2
L 1031	M.RFC	1uH			LK1608 1R0K-T	L1690687		1-	B	e1
L 1032	M.RFC	0.082uH			HK1608 82NJ-T	L1690527		1-	B	b2
L 1033	M.RFC	0.82uH			LK1608 R82K-T	L1690417		1-	B	b2
L 1036	COIL	0.025uH			AS030521-25NK	L0022585		1-	B	b2
L 1038	COIL				E2 0.35-1.6-5.5T-L	L0022616		1-	B	c2
L 1039	CHIP COIL	15uH			LQH32MN150K23L	L1690089		1-	A	D2
L 1040	M.RFC	3.3uH			LK1608 3R3K-T	L1690686		1-	B	b1
L 1041	M.RFC	3.3uH			LK1608 3R3K-T	L1690686		1-	B	b2
L 1042	M.RFC	0.12uH			HK1608 R12J-T	L1690937		1-	B	c2
L 1043	M.RFC	0.047uH			HK1608 47NJ-T	L1690524		1-	B	a2
L 1044	M.RFC	0.22uH			HK1608 R22J-T	L1690940		1-	B	d1
MC1001	MICROPHONE ELEMENT				SKB-2244S-C1033G04	M3290039		1-	A	D1
P 1001	SPRING CONNECTOR					R0152490		1-	B	a1
Q 1002	TRANSISTOR				UMX1N TN	G3070324		1-	A	D1
Q 1003	TRANSISTOR				IMZ2A T108	G3070060		1-	A	E1
Q 1004	TRANSISTOR				2SA1602A-T11-1F	G3116028F		1-	A	C1
Q 1005	IC				NJM2070M(TE2)	G1092944		1-	A	E2
Q 1006	TRANSISTOR				2SC4154-T11-1E	G3341548E		1-	A	E3
Q 1007	TRANSISTOR				CPH6102-TL	G3070223		1-	A	E3
Q 1008	FET				RD07MVS1(TAPE)	G3070320		1-	B	b1
Q 1009	TRANSISTOR				2SA1602A-T11-1F	G3116028F		1-	B	d3
Q 1010	IC				LA8630M-B-TE-R	G1093452		1-	B	d3

MAIN Unit

REF.	DESCRIPTION	VALUE	V/W	TOL.	MFR'S DESIG	VXSTD P/N	VERS.	LOT.	SIDE	LAY ADR
Q 1011	FET				2SK3541 T2L	G3835417		1-	B	d3
Q 1012	TRANSISTOR				CPH6102-TL	G3070223		1-	B	e3
Q 1013	TRANSISTOR				UMX1N TN	G3070324		1-	B	e2
Q 1014	FET				RD01MUS1(TAPE)	G3070321		1-	B	c1
Q 1015	IC				M62364FP 600D	G1093033		1-	B	d1
Q 1016	TRANSISTOR				2SC4154-T11-1E	G3341548E		1-	B	d1
Q 1017	TRANSISTOR				CPH6102-TL	G3070223		1-	B	e3
Q 1018	TRANSISTOR				UMX1N TN	G3070324		1-	B	e3
Q 1019	TRANSISTOR				2SC5006-T1	G3350068		1-	B	a2
Q 1020	TRANSISTOR				2SC5227-4-TB	G3352278D		1-	B	c1
Q 1021	IC				AK2342B	G1093143		1-	B	e1
Q 1022	TRANSISTOR				DTB123EK T146	G3070022		1-	B	e3
Q 1025	IC				NJM2871AF35(TAPE)	G1093899		1-	B	e3
Q 1026	TRANSISTOR				2SC5005-T1	G3350058		1-	B	c1
Q 1027	TRANSISTOR				2SC4154-T11-1E	G3341548E		1-	B	b2
Q 1028	TRANSISTOR				DTC144EE TL	G3070075		1-	B	c2
Q 1029	FET				3SK320(TE85L)	G4803208		1-	B	b2
Q 1030	FET				2SK210GR TE85R	G3802107G		1-	B	c2
Q 1031	TRANSISTOR				DTC144EE TL	G3070075		1-	B	c1
Q 1032	TRANSISTOR				DTC144EE TL	G3070075		1-	B	c2
Q 1033	TRANSISTOR				2SC5226-4/5-TL	G3352268Z		1-	B	c2
Q 1034	TRANSISTOR				2SC4154-T11-1E	G3341548E	W/LCD	1-	A	C3
Q 1035	TRANSISTOR				DTC114TE TL	G3070225	W/LCD	1-	A	B3
Q 1036	IC				BR93L56RFVM-WTR	G1093928		1-	A	D2
Q 1037	TRANSISTOR				2SC4154-T11-1E	G3341548E		1-	A	D2
Q 1038	FET				2SK3541 T2L	G3835417		1-	B	e2
Q 1039	TRANSISTOR				DTA144EE TL	G3070074		1-	A	D3
Q 1040	IC				BD4835FVE-TR	G1093967		1-	A	D3
Q 1041	TRANSISTOR				2SC4215Y TE85R	G3342157Y		1-	B	b2
Q 1043	TRANSISTOR				UMC5N TR	G3070137		1-	B	d1
Q 1044	TRANSISTOR				2SC4154-T11-1E	G3341548E		1-	A	E1
Q 1045	TRANSISTOR				2SC4154-T11-1E	G3341548E	W/LCD	1-	A	C3
Q 1046	TRANSISTOR				DTC114TE TL	G3070225	W/LCD	1-	A	C3
Q 1047	IC				LC87F74C8A-TQFP-E	*		1-	A	C2
Q 1048	IC				TA31136FN(EL)	G1091605		1-	B	c2
Q 1051	IC				MB15A01PFV1-G-BND-EF	G1092545		1-	B	d1
Q 1052	TRANSISTOR				DTC144EE TL	G3070075		1-	B	d3
Q 1054	IC				NJM12904R(TE1)	G1093337		1-	A	D2
Q 1055	FET				2SK3541 T2L	G3835417		1-	B	e1
Q 1056	TRANSISTOR				DTC144EE TL	G3070075		1-	B	d3
Q 1058	TRANSISTOR				CPH6102-TL	G3070223		1-	B	e2
Q 1059	TRANSISTOR				UMX1N TN	G3070324		1-	B	e2
Q 1060	IC				NJU7007F2-TE1	G1093617		1-	B	d1
Q 1061	TRANSISTOR				DTC144EE TL	G3070075		1-	B	d2
Q 1062	IC				TC7W74FU TE12R	G1091788		1-	B	e1
Q 1063	TRANSISTOR				UMX1N TN	G3070324		1-	A	E1
R 1002	CHIP RES.	15k	1/16W	5%	RMC1/16S 153JTH	J24189039		1-	A	E1
R 1003	CHIP RES.	330	1/16W	5%	RMC1/16S 331JTH	J24189019		1-	A	D1
R 1004	CHIP RES.	2.2k	1/16W	5%	RMC1/16S 222JTH	J24189029		1-	A	C1
R 1005	CHIP RES.	2.2	1/16W	5%	RMC1/16 2R2JATP	J24185229		1-	A	E2
R 1006	CHIP RES.	680	1/16W	5%	RMC1/16S 681JTH	J24189023		1-	A	E2
R 1007	CHIP RES.	0	1/16W	5%	RMC1/16S JPTH	J24189070		1-	A	D1
R 1008	CHIP RES.	0	1/16W	5%	RMC1/16S JPTH	J24189070		1-	A	D1
R 1009	CHIP RES.	0	1/16W	5%	RMC1/16S JPTH	J24189070		1-	A	D1
R 1010	CHIP RES.	10k	1/16W	5%	RMC1/16S 103JTH	J24189037		1-	A	D1
R 1011	CHIP RES.	68	1/16W	5%	RMC1/16 680JATP	J24185680		1-	B	a1
R 1013	CHIP RES.	0	1/16W	5%	RMC1/16S JPTH	J24189070		1-	A	D1
R 1014	CHIP RES.	68	1/16W	5%	RMC1/16 680JATP	J24185680		1-	B	a1
R 1015	CHIP RES.	0.33	1/8W	10%	RMC1/8 R33KTP	J24219001		1-	A	E1
R 1016	CHIP RES.	5.6k	1/16W	5%	RMC1/16S 562JTH	J24189034		1-	A	E1
R 1017	CHIP RES.	0	1/16W	5%	RMC1/16S JPTH	J24189070		1-	A	D1
R 1018	CHIP RES.	5.6k	1/16W	5%	RMC1/16S 562JTH	J24189034		1-	A	E1
R 1020	CHIP RES.	47k	1/16W	5%	RMC1/16S 473JTH	J24189045		1-	A	E1
R 1021	CHIP RES.	330	1/16W	5%	RMC1/16S 331JTH	J24189019		1-	A	E1
R 1022	CHIP RES.	0	1/16W	5%	RMC1/16S JPTH	J24189070		1-	B	d1
R 1023	CHIP RES.	47k	1/16W	5%	RMC1/16S 473JTH	J24189045		1-	A	C1
R 1024	CHIP RES.	56k	1/16W	5%	RMC1/16S 563JTH	J24189046		1	A	C1

REF.	DESCRIPTION	VALUE	V/W	TOL.	MFR'S DESIG	VXSTD P/N	VERS.	LOT.	SIDE	LAY ADR
R 1024	CHIP RES.	8.2k	1/16W	5%	RMC1/16S 822JTH	J24189036		2-	A	C1
R 1025	CHIP RES.	0	1/16W	5%	RMC1/16S JPTH	J24189070		1-	A	D2
R 1026	CHIP RES.	4.7k	1/16W	5%	RMC1/16S 472JTH	J24189033		1-	A	C1
R 1027	CHIP RES.	0	1/16W	5%	RMC1/16S JPTH	J24189070		1-	A	D3
R 1028	CHIP RES.	470	1/16W	5%	RMC1/16S 471JTH	J24189021		1-	A	C1
R 1029	CHIP RES.	2.2k	1/16W	5%	RMC1/16S 222JTH	J24189029		1-	A	C1
R 1030	CHIP RES.	47k	1/16W	5%	RMC1/16S 473JTH	J24189045		1-	A	D1
R 1031	CHIP RES.	0	1/16W	5%	RMC1/16S JPTH	J24189070		1-	B	d3
R 1032	CHIP RES.	100	1/16W	5%	RMC1/16S 101JTH	J24189013		1-	A	E2
R 1033	CHIP RES.	220	1/16W	5%	RMC1/16 221JATP	J24185221		1-	A	E3
R 1034	CHIP RES.	220	1/16W	5%	RMC1/16 221JATP	J24185221		1-	A	E3
R 1035	CHIP RES.	22k	1/16W	5%	RMC1/16S 223JTH	J24189041		1-	A	D3
R 1036	CHIP RES.	4.7k	1/16W	5%	RMC1/16S 472JTH	J24189033		1-	A	E3
R 1037	CHIP RES.	220	1/2W	5%	RMC1/2 221JCTP	J24275221		1-	B	b1
R 1038	CHIP RES.	0.33	1/8W	10%	RMC1/8 R33KTP	J24219001		1-	A	E1
R 1040	CHIP RES.	0.33	1/8W	10%	RMC1/8 R33KTP	J24219001		1-	A	E1
R 1041	CHIP RES.	1k	1/16W	5%	RMC1/16S 102JTH	J24189025		1-	B	b1
R 1042	CHIP RES.	0	1/16W	5%	RMC1/16 000JATP	J24185000		1-	B	b1
R 1043	CHIP RES.	330k	1/16W	5%	RMC1/16S 334JTH	J24189055		1-	A	D1
R 1044	CHIP RES.	2.2k	1/16W	5%	RMC1/16S 222JTH	J24189029		1-	B	d1
R 1045	CHIP RES.	1.5M	1/16W	5%	RMC1/16S 155JTH	J24189063		1	B	e1
R 1045	CHIP RES.	220k	1/16W	5%	RMC1/16S 224JTH	J24189053		2-	B	e1
R 1046	CHIP RES.	0	1/16W	5%	RMC1/16S JPTH	J24189070		1-	B	d2
R 1047	CHIP RES.	82k	1/16W	5%	RMC1/16S 823JTH	J24189048		1-	A	D1
R 1048	CHIP RES.	4.7k	1/16W	5%	RMC1/16S 472JTH	J24189033		1-	B	d1
R 1049	CHIP RES.	0	1/16W	5%	RMC1/16S JPTH	J24189070		1-	B	d2
R 1050	CHIP RES.	100k	1/16W	5%	RMC1/16S 104JTH	J24189049		1-	B	d1
R 1051	CHIP RES.	5.6k	1/16W	5%	RMC1/16S 562JTH	J24189034		1-	B	d3
R 1052	CHIP RES.	100k	1/16W	5%	RMC1/16S 104JTH	J24189049		1-	B	d3
R 1053	CHIP RES.	100k	1/16W	5%	RMC1/16S 104JTH	J24189049		1-	B	d3
R 1054	CHIP RES.	47k	1/16W	5%	RMC1/16S 473JTH	J24189045		1-	B	d3
R 1056	CHIP RES.	5.6k	1/16W	5%	RMC1/16S 562JTH	J24189034		1-	B	d2
R 1057	CHIP RES.	6.8k	1/16W	5%	RMC1/16S 682JTH	J24189035		1-	B	d1
R 1058	CHIP RES.	4.7k	1/16W	5%	RMC1/16S 472JTH	J24189033		1-	A	C1
R 1059	CHIP RES.	10k	1/16W	5%	RMC1/16S 103JTH	J24189037		1-	B	e3
R 1060	CHIP RES.	100k	1/16W	5%	RMC1/16S 104JTH	J24189049		1-	A	C1
R 1061	CHIP RES.	3.3k	1/16W	5%	RMC1/16S 332JTH	J24189031		1-	B	e2
R 1062	CHIP RES.	2.2k	1/16W	5%	RMC1/16S 222JTH	J24189029		1-	B	e3
R 1063	CHIP RES.	12k	1/16W	5%	RMC1/16S 123JTH	J24189038		1-	B	e3
R 1064	CHIP RES.	33k	1/16W	5%	RMC1/16S 333JTH	J24189043		1-	B	e3
R 1065	CHIP RES.	100k	1/16W	5%	RMC1/16S 104JTH	J24189049		1-	B	a2
R 1066	CHIP RES.	100k	1/16W	5%	RMC1/16S 104JTH	J24189049		1-	B	a2
R 1067	CHIP RES.	100	1/4W	5%	RMC1/4 101JATP	J24245101		1-	B	b1
R 1068	CHIP RES.	47	1/16W	5%	RMC1/16S 470JTH	J24189009		1-	B	c1
R 1069	CHIP RES.	3.3k	1/16W	5%	RMC1/16S 332JTH	J24189031		1	B	c1
R 1069	CHIP RES.	1k	1/16W	5%	RMC1/16S 102JTH	J24189025		2-	B	c1
R 1070	CHIP RES.	220	1/16W	5%	RMC1/16S 221JTH	J24189017		1-	B	c1
R 1071	CHIP RES.	220k	1/16W	1%	RMC1/16 224FTP	J24183224		1-	A	D2
R 1072	CHIP RES.	12k	1/16W	5%	RMC1/16S 123JTH	J24189038		1	B	c1
R 1072	CHIP RES.	15k	1/16W	5%	RMC1/16S 153JTH	J24189039		2-	B	c1
R 1073	CHIP RES.	10k	1/16W	1%	RMC1/16 103FTP	J24183103		1-	A	D2
R 1074	CHIP RES.	0	1/16W	5%	RMC1/16S JPTH	J24189070		1-	B	d1
R 1076	CHIP RES.	100k	1/16W	5%	RMC1/16S 104JTH	J24189049		1-	A	E2
R 1077	CHIP RES.	82k	1/16W	5%	RMC1/16S 823JTH	J24189048		1-	B	e1
R 1078	CHIP RES.	150k	1/16W	5%	RMC1/16S 154JTH	J24189051		1-	B	d1
R 1079	CHIP RES.	4.7k	1/16W	5%	RMC1/16S 472JTH	J24189033		1-	B	e1
R 1080	CHIP RES.	6.8k	1/16W	5%	RMC1/16S 682JTH	J24189035		1-	B	d1
R 1081	CHIP RES.	33k	1/16W	5%	RMC1/16S 333JTH	J24189043		1-	B	e1
R 1082	CHIP RES.	6.8k	1/16W	5%	RMC1/16S 682JTH	J24189035		1-	B	d1
R 1083	CHIP RES.	1k	1/16W	5%	RMC1/16S 102JTH	J24189025		1-	B	d1
R 1084	CHIP RES.	330k	1/16W	5%	RMC1/16S 334JTH	J24189055		1-	B	e1
R 1085	CHIP RES.	33k	1/16W	5%	RMC1/16S 333JTH	J24189043		1-	B	e1
R 1086	CHIP RES.	10k	1/16W	5%	RMC1/16S 103JTH	J24189037		1-	B	e3
R 1087	CHIP RES.	100k	1/16W	5%	RMC1/16S 104JTH	J24189049		1-	A	D2
R 1088	CHIP RES.	12k	1/16W	5%	RMC1/16S 123JTH	J24189038		1-	B	e3
R 1089	CHIP RES.	560	1/16W	5%	RMC1/16S 561JTH	J24189022		1-	A	D2
R 1090	CHIP RES.	3.3k	1/16W	5%	RMC1/16S 332JTH	J24189031		1-	B	e3

MAIN Unit

REF.	DESCRIPTION	VALUE	V/W	TOL.	MFR'S DESIG	VXSTD P/N	VERS.	LOT.	SIDE	LAY ADR
R 1091	CHIP RES.	2.2k	1/16W	5%	RMC1/16S 222JTH	J24189029		1-	B	e3
R 1092	CHIP RES.	33k	1/16W	5%	RMC1/16S 333JTH	J24189043		1-	B	e3
R 1093	CHIP RES.	0	1/16W	5%	RMC1/16S JPTH	J24189070		1-	B	a2
R 1094	CHIP RES.	100k	1/16W	5%	RMC1/16S 104JTH	J24189049		1-	B	a2
R 1095	CHIP RES.	100k	1/16W	5%	RMC1/16S 104JTH	J24189049		1-	B	d1
R 1096	CHIP RES.	100	1/16W	5%	RMC1/16 101JATP	J24185101		1-	B	b1
R 1097	CHIP RES.	100	1/16W	5%	RMC1/16S 101JTH	J24189013		1-	B	a2
R 1098	CHIP RES.	0	1/16W	5%	RMC1/16S JPTH	J24189070		1-	B	d2
R 1099	CHIP RES.	15	1/16W	5%	RMC1/16S 150JTH	J24189003		1-	B	c1
R 1100	CHIP RES.	27k	1/16W	5%	RMC1/16S 273JTH	J24189042		1-	B	c1
R 1101	CHIP RES.	10	1/16W	5%	RMC1/16S 100JTH	J24189001		1-	B	c1
R 1102	CHIP RES.	0	1/16W	5%	RMC1/16S JPTH	J24189070		1-	B	d1
R 1104	CHIP RES.	470k	1/16W	5%	RMC1/16S 474JTH	J24189057		1-	B	d1
R 1106	CHIP RES.	0	1/16W	5%	RMC1/16S JPTH	J24189070		1-	B	d1
R 1107	CHIP RES.	330k	1/16W	5%	RMC1/16S 334JTH	J24189055		1-	B	e1
R 1108	CHIP RES.	0	1/16W	5%	RMC1/16S JPTH	J24189070		1-	B	d1
R 1109	CHIP RES.	10k	1/16W	5%	RMC1/16S 103JTH	J24189037		1-	B	d1
R 1110	CHIP RES.	330k	1/16W	5%	RMC1/16S 334JTH	J24189055		1-	B	e1
R 1111	CHIP RES.	0	1/16W	5%	RMC1/16S JPTH	J24189070		1-	B	e1
R 1112	CHIP RES.	100k	1/16W	5%	RMC1/16S 104JTH	J24189049		1-	B	d1
R 1113	CHIP RES.	330k	1/16W	5%	RMC1/16S 334JTH	J24189055		1-	B	e1
R 1114	CHIP RES.	47k	1/16W	5%	RMC1/16S 473JTH	J24189045		1-	B	e1
R 1115	CHIP RES.	120k	1/16W	5%	RMC1/16S 124JTH	J24189050		1-	B	e1
R 1116	CHIP RES.	220k	1/16W	5%	RMC1/16S 224JTH	J24189053		1-	B	e1
R 1117	CHIP RES.	270k	1/16W	5%	RMC1/16S 274JTH	J24189054		1-	B	e1
R 1118	CHIP RES.	100k	1/16W	5%	RMC1/16S 104JTH	J24189049		1-	B	e1
R 1119	CHIP RES.	270k	1/16W	5%	RMC1/16S 274JTH	J24189054		1-	B	e1
R 1120	CHIP RES.	12k	1/16W	5%	RMC1/16S 123JTH	J24189038		1-	B	e2
R 1121	CHIP RES.	100k	1/16W	5%	RMC1/16S 104JTH	J24189049		1-	B	e1
R 1122	CHIP RES.	10k	1/16W	5%	RMC1/16S 103JTH	J24189037		1-	B	e2
R 1123	CHIP RES.	100k	1/16W	5%	RMC1/16S 104JTH	J24189049		1-	B	e1
R 1124	CHIP RES.	82k	1/16W	5%	RMC1/16S 823JTH	J24189048		1-	A	E2
R 1125	CHIP RES.	47k	1/16W	5%	RMC1/16S 473JTH	J24189045		1-	A	D2
R 1126	CHIP RES.	10k	1/16W	5%	RMC1/16S 103JTH	J24189037		1-	A	E2
R 1127	CHIP RES.	22k	1/16W	5%	RMC1/16S 223JTH	J24189041		1-	A	E2
R 1128	CHIP RES.	0	1/16W	5%	RMC1/16S JPTH	J24189070		1-	B	d1
R 1129	CHIP RES.	100	1/16W	5%	RMC1/16S 101JTH	J24189013		1-	B	a2
R 1130	CHIP RES.	100k	1/16W	5%	RMC1/16S 104JTH	J24189049		1-	B	a2
R 1131	CHIP RES.	100k	1/16W	5%	RMC1/16S 104JTH	J24189049		1-	B	a2
R 1134	CHIP RES.	2.2k	1/16W	5%	RMC1/16S 222JTH	J24189029		1-	B	c2
R 1135	CHIP RES.	1.5k	1/16W	5%	RMC1/16S 152JTH	J24189027		1-	B	c2
R 1137	CHIP RES.	0	1/16W	5%	RMC1/16S JPTH	J24189070		1-	B	c2
R 1138	CHIP RES.	4.7k	1/16W	5%	RMC1/16S 472JTH	J24189033		1-	B	b2
R 1139	CHIP RES.	330k	1/16W	5%	RMC1/16S 334JTH	J24189055		1-	B	e1
R 1140	CHIP RES.	1.5M	1/16W	5%	RMC1/16S 155JTH	J24189063		1-	B	e1
R 1141	CHIP RES.	47k	1/16W	5%	RMC1/16S 473JTH	J24189045		1-	B	d2
R 1142	CHIP RES.	220k	1/16W	5%	RMC1/16S 224JTH	J24189053		1-	B	e1
R 1143	CHIP RES.	220k	1/16W	5%	RMC1/16S 224JTH	J24189053		1-	B	e1
R 1144	CHIP RES.	1M	1/16W	5%	RMC1/16S 105JTH	J24189061		1-	B	e1
R 1145	CHIP RES.	33k	1/16W	5%	RMC1/16S 333JTH	J24189043		1-	B	e2
R 1146	CHIP RES.	100k	1/16W	5%	RMC1/16S 104JTH	J24189049		1-	B	a3
R 1147	CHIP RES.	2.2k	1/16W	5%	RMC1/16S 222JTH	J24189029		1-	B	b2
R 1148	CHIP RES.	0	1/16W	5%	RMC1/16S JPTH	J24189070		1-	B	b2
R 1149	CHIP RES.	100	1/16W	5%	RMC1/16S 101JTH	J24189013		1-	B	c2
R 1150	CHIP RES.	47k	1/16W	5%	RMC1/16S 473JTH	J24189045		1-	B	c2
R 1151	CHIP RES.	47	1/16W	5%	RMC1/16S 470JTH	J24189009		1-	B	c2
R 1152	CHIP RES.	220k	1/16W	5%	RMC1/16S 224JTH	J24189053		1-	B	c2
R 1153	CHIP RES.	100k	1/16W	5%	RMC1/16S 104JTH	J24189049		1-	B	c2
R 1154	CHIP RES.	33k	1/16W	5%	RMC1/16S 333JTH	J24189043		1-	B	c2
R 1155	CHIP RES.	680	1/16W	5%	RMC1/16S 681JTH	J24189023		1-	B	c2
R 1156	CHIP RES.	1k	1/16W	5%	RMC1/16S 102JTH	J24189025		1-	B	b2
R 1157	CHIP RES.	1k	1/16W	5%	RMC1/16S 102JTH	J24189025		1-	B	b2
R 1158	CHIP RES.	82	1/16W	5%	RMC1/16S 820JTH	J24189012		1-	B	b2
R 1159	CHIP RES.	560	1/16W	5%	RMC1/16S 561JTH	J24189022		1-	B	b2
R 1160	CHIP RES.	0	1/16W	5%	RMC1/16S JPTH	J24189070		1-	B	b2
R 1161	CHIP RES.	10	1/16W	5%	RMC1/16S 100JTH	J24189001		1-	B	c2
R 1162	CHIP RES.	100	1/16W	5%	RMC1/16S 101JTH	J24189013		1-	B	c2

REF.	DESCRIPTION	VALUE	V/W	TOL.	MFR'S DESIG	VXSTD P/N	VERS.	LOT.	SIDE	LAY ADR
R 1163	CHIP RES.	22	1/16W	5%	RMC1/16S 220JTH	J24189005		1-	B	b1
R 1164	CHIP RES.	10k	1/16W	5%	RMC1/16S 103JTH	J24189037		1-	B	c2
R 1165	CHIP RES.	1k	1/16W	5%	RMC1/16S 102JTH	J24189025	W/LCD	1-	A	C3
R 1166	CHIP RES.	180	1/16W	5%	RMC1/16S 181JTH	J24189016	W/LCD	1-	B	d3
R 1167	CHIP RES.	180	1/16W	5%	RMC1/16S 181JTH	J24189016	W/LCD	1-	B	d3
R 1168	CHIP RES.	100	1/16W	5%	RMC1/16S 101JTH	J24189013		1-	A	D3
R 1169	CHIP RES.	10k	1/16W	5%	RMC1/16S 103JTH	J24189037		1-	B	e2
R 1170	CHIP RES.	10k	1/16W	5%	RMC1/16S 103JTH	J24189037		1-	B	e2
R 1171	CHIP RES.	470k	1/16W	5%	RMC1/16S 474JTH	J24189057		1-	A	D2
R 1172	CHIP RES.	0	1/16W	5%	RMC1/16S JPTH	J24189070		1-	B	e1
R 1173	CHIP RES.	47k	1/16W	5%	RMC1/16S 473JTH	J24189045		1-	A	D3
R 1174	CHIP RES.	6.8k	1/16W	5%	RMC1/16S 682JTH	J24189035		1-	A	D3
R 1175	CHIP RES.	15k	1/16W	5%	RMC1/16S 153JTH	J24189039		1-	A	D3
R 1176	CHIP RES.	22	1/16W	5%	RMC1/16S 220JTH	J24189005		1-	B	b2
R 1177	CHIP RES.	390	1/16W	5%	RMC1/16S 391JTH	J24189020		1-	B	b2
R 1178	CHIP RES.	47k	1/16W	5%	RMC1/16S 473JTH	J24189045		1-	B	b2
R 1179	CHIP RES.	1k	1/16W	5%	RMC1/16S 102JTH	J24189025		1-	B	b3
R 1180	CHIP RES.	33	1/16W	5%	RMC1/16S 330JTH	J24189007		1-	B	b2
R 1181	CHIP RES.	33	1/16W	5%	RMC1/16S 330JTH	J24189007		1-	B	b2
R 1182	CHIP RES.	10k	1/16W	5%	RMC1/16S 103JTH	J24189037		1-	B	c2
R 1184	CHIP RES.	2.7k	1/16W	5%	RMC1/16S 272JTH	J24189030		1-	B	d2
R 1185	CHIP RES.	2.7k	1/16W	5%	RMC1/16S 272JTH	J24189030		1-	B	d2
R 1186	CHIP RES.	0	1/16W	5%	RMC1/16S JPTH	J24189070		1-	B	d2
R 1188	CHIP RES.	33	1/16W	5%	RMC1/16S 330JTH	J24189007		1-	B	d1
R 1189	CHIP RES.	33	1/16W	5%	RMC1/16S 330JTH	J24189007		1-	B	d1
R 1190	CHIP RES.	1k	1/16W	5%	RMC1/16S 102JTH	J24189025		1-	A	E1
R 1191	CHIP RES.	1k	1/16W	5%	RMC1/16S 102JTH	J24189025	W/LCD	1-	A	C3
R 1192	CHIP RES.	330	1/16W	5%	RMC1/16S 331JTH	J24189019		1-	A	E1
R 1193	CHIP RES.	150	1/16W	5%	RMC1/16S 151JTH	J24189015		1-	A	E1
R 1194	CHIP RES.	10k	1/16W	5%	RMC1/16S 103JTH	J24189037		1-	A	D3
R 1195	CHIP RES.	47k	1/16W	5%	RMC1/16S 473JTH	J24189045		1-	A	D2
R 1196	CHIP RES.	1k	1/16W	5%	RMC1/16S 102JTH	J24189025		1-	A	D2
R 1197	CHIP RES.	100	1/16W	5%	RMC1/16S 101JTH	J24189013	W/LCD	1-	A	C3
R 1198	CHIP RES.	1k	1/16W	5%	RMC1/16S 102JTH	J24189025		1-	A	D2
R 1199	CHIP RES.	0	1/16W	5%	RMC1/16S JPTH	J24189070		1-	B	e1
R 1200	CHIP RES.	1k	1/16W	5%	RMC1/16S 102JTH	J24189025		1-	A	D2
R 1201	CHIP RES.	1k	1/16W	5%	RMC1/16S 102JTH	J24189025		1-	A	D2
R 1202	CHIP RES.	22k	1/16W	5%	RMC1/16S 223JTH	J24189041		1-	A	D2
R 1203	CHIP RES.	1k	1/16W	5%	RMC1/16S 102JTH	J24189025		1-	A	D2
R 1204	CHIP RES.	1k	1/16W	5%	RMC1/16S 102JTH	J24189025		1-	A	D2
R 1205	CHIP RES.	1k	1/16W	5%	RMC1/16S 102JTH	J24189025		1-	A	D2
R 1206	CHIP RES.	1k	1/16W	5%	RMC1/16S 102JTH	J24189025		1-	A	D2
R 1207	CHIP RES.	1k	1/16W	5%	RMC1/16S 102JTH	J24189025		1-	A	D2
R 1208	CHIP RES.	1k	1/16W	5%	RMC1/16S 102JTH	J24189025		1-	A	D2
R 1209	CHIP RES.	1k	1/16W	5%	RMC1/16S 102JTH	J24189025		1-	A	D2
R 1210	CHIP RES.	1k	1/16W	5%	RMC1/16S 102JTH	J24189025		1-	A	D2
R 1211	CHIP RES.	1k	1/16W	5%	RMC1/16S 102JTH	J24189025		1-	A	D2
R 1212	CHIP RES.	470	1/16W	5%	RMC1/16S 471JTH	J24189021		1-	A	C3
R 1214	CHIP RES.	1k	1/16W	5%	RMC1/16S 102JTH	J24189025		1-	A	D2
R 1215	CHIP RES.	1k	1/16W	5%	RMC1/16S 102JTH	J24189025		1-	A	D2
R 1216	CHIP RES.	1k	1/16W	5%	RMC1/16S 102JTH	J24189025		1-	A	D2
R 1217	CHIP RES.	1k	1/16W	5%	RMC1/16S 102JTH	J24189025		1-	A	D2
R 1218	CHIP RES.	1k	1/16W	5%	RMC1/16S 102JTH	J24189025		1-	A	D1
R 1219	CHIP RES.	1k	1/16W	5%	RMC1/16S 102JTH	J24189025		1-	A	D1
R 1220	CHIP RES.	1k	1/16W	5%	RMC1/16S 102JTH	J24189025		1-	A	D1
R 1221	CHIP RES.	1k	1/16W	5%	RMC1/16S 102JTH	J24189025		1-	A	D1
R 1222	CHIP RES.	1k	1/16W	5%	RMC1/16S 102JTH	J24189025		1-	A	D1
R 1223	CHIP RES.	1k	1/16W	5%	RMC1/16S 102JTH	J24189025		1-	A	D1
R 1224	CHIP RES.	1k	1/16W	5%	RMC1/16S 102JTH	J24189025		1-	A	D1
R 1225	CHIP RES.	47k	1/16W	5%	RMC1/16S 473JTH	J24189045		1-	A	D3
R 1226	CHIP RES.	1k	1/16W	5%	RMC1/16S 102JTH	J24189025		1-	A	C1
R 1227	CHIP RES.	0	1/16W	5%	RMC1/16S JPTH	J24189070		1-	A	D1
R 1228	CHIP RES.	1k	1/16W	5%	RMC1/16S 102JTH	J24189025		1-	A	C1
R 1230	CHIP RES.	1k	1/16W	5%	RMC1/16S 102JTH	J24189025		1-	B	c2
R 1231	CHIP RES.	0	1/16W	5%	RMC1/16S JPTH	J24189070		1-	B	d2
R 1232	CHIP RES.	0	1/16W	5%	RMC1/16S JPTH	J24189070		1-	B	d1
R 1234	CHIP RES.	2.2k	1/16W	5%	RMC1/16S 222JTH	J24189029		1-	B	d2

MAIN Unit

REF.	DESCRIPTION	VALUE	V/W	TOL.	MFR'S DESIG	VXSTD P/N	VERS.	LOT.	SIDE	LAY ADR
R 1235	CHIP RES.	100	1/16W	5%	RMC1/16S 101JTH	J24189013		1-	B	d2
R 1236	CHIP RES.	0	1/16W	5%	RMC1/16S JPTH	J24189070		1-	B	d2
R 1237	CHIP RES.	47k	1/16W	5%	RMC1/16S 473JTH	J24189045		1-	B	d2
R 1238	CHIP RES.	1k	1/16W	5%	RMC1/16S 102JTH	J24189025		1-	A	C2
R 1239	CHIP RES.	1k	1/16W	5%	RMC1/16S 102JTH	J24189025		1-	A	C2
R 1240	CHIP RES.	1k	1/16W	5%	RMC1/16S 102JTH	J24189025		1-	A	C3
R 1241	CHIP RES.	1k	1/16W	5%	RMC1/16S 102JTH	J24189025		1-	A	C3
R 1242	CHIP RES.	1k	1/16W	5%	RMC1/16S 102JTH	J24189025		1-	A	C3
R 1243	CHIP RES.	1k	1/16W	5%	RMC1/16S 102JTH	J24189025		1-	A	C3
R 1244	CHIP RES.	1k	1/16W	5%	RMC1/16S 102JTH	J24189025		1-	A	C3
R 1245	CHIP RES.	1k	1/16W	5%	RMC1/16S 102JTH	J24189025		1-	A	C3
R 1246	CHIP RES.	1k	1/16W	5%	RMC1/16S 102JTH	J24189025		1-	A	C3
R 1247	CHIP RES.	1k	1/16W	5%	RMC1/16S 102JTH	J24189025		1-	A	C2
R 1248	CHIP RES.	1k	1/16W	5%	RMC1/16S 102JTH	J24189025		1-	A	D1
R 1249	CHIP RES.	10k	1/16W	5%	RMC1/16S 103JTH	J24189037		1-	A	D1
R 1250	CHIP RES.	1k	1/16W	5%	RMC1/16S 102JTH	J24189025		1-	A	C1
R 1251	CHIP RES.	1k	1/16W	5%	RMC1/16S 102JTH	J24189025		1-	A	C1
R 1252	CHIP RES.	1k	1/16W	5%	RMC1/16S 102JTH	J24189025		1-	A	C1
R 1253	CHIP RES.	1k	1/16W	5%	RMC1/16S 102JTH	J24189025		1-	A	C1
R 1254	CHIP RES.	1k	1/16W	5%	RMC1/16S 102JTH	J24189025		1-	A	C1
R 1255	CHIP RES.	1k	1/16W	5%	RMC1/16S 102JTH	J24189025		1-	A	C1
R 1256	CHIP RES.	82k	1/16W	5%	RMC1/16S 823JTH	J24189048		1-	A	C1
R 1257	CHIP RES.	39k	1/16W	5%	RMC1/16S 393JTH	J24189044		1-	A	C1
R 1258	CHIP RES.	22k	1/16W	5%	RMC1/16S 223JTH	J24189041		1-	A	C1
R 1259	CHIP RES.	2.7k	1/16W	5%	RMC1/16S 272JTH	J24189030		1-	B	c2
R 1260	CHIP RES.	2.2k	1/16W	5%	RMC1/16S 222JTH	J24189029		1-	B	d2
R 1261	CHIP RES.	4.7k	1/16W	5%	RMC1/16S 472JTH	J24189033		1-	B	d2
R 1262	CHIP RES.	5.6k	1/16W	5%	RMC1/16S 562JTH	J24189034		1-	B	d3
R 1263	CHIP RES.	180k	1/16W	5%	RMC1/16S 184JTH	J24189052		1-	B	c2
R 1264	CHIP RES.	180k	1/16W	5%	RMC1/16S 184JTH	J24189052		1-	B	d2
R 1265	CHIP RES.	3.9k	1/16W	5%	RMC1/16S 392JTH	J24189032		1-	B	c3
R 1266	CHIP RES.	0	1/16W	5%	RMC1/16S JPTH	J24189070		1-	B	d3
R 1267	CHIP RES.	3.3k	1/16W	5%	RMC1/16S 332JTH	J24189031		1-	B	c3
R 1268	CHIP RES.	2.2k	1/16W	5%	RMC1/16S 222JTH	J24189029		1-	B	e2
R 1269	CHIP RES.	12k	1/16W	5%	RMC1/16S 123JTH	J24189038		1-	B	c3
R 1270	CHIP RES.	2.2k	1/16W	5%	RMC1/16S 222JTH	J24189029		1-	B	c1
R 1271	CHIP RES.	12k	1/16W	5%	RMC1/16S 123JTH	J24189038		1-	B	c3
R 1272	CHIP RES.	12k	1/16W	5%	RMC1/16S 123JTH	J24189038		1-	B	c3
R 1274	CHIP RES.	2.2k	1/16W	5%	RMC1/16S 222JTH	J24189029		1-	B	c1
R 1275	CHIP RES.	2.2k	1/16W	5%	RMC1/16S 222JTH	J24189029		1-	B	d1
R 1276	CHIP RES.	6.8k	1/16W	5%	RMC1/16S 682JTH	J24189035		1-	A	C2
R 1277	CHIP RES.	47k	1/16W	5%	RMC1/16S 473JTH	J24189045		1-	A	C2
R 1278	CHIP RES.	1k	1/16W	5%	RMC1/16S 102JTH	J24189025		1-	A	C2
R 1279	CHIP RES.	33k	1/16W	5%	RMC1/16S 333JTH	J24189043		1-	A	C2
R 1280	CHIP RES.	47k	1/16W	5%	RMC1/16S 473JTH	J24189045		1-	A	C2
R 1281	CHIP RES.	47k	1/16W	5%	RMC1/16S 473JTH	J24189045		1-	A	C2
R 1282	CHIP RES.	10k	1/16W	5%	RMC1/16S 103JTH	J24189037		1-	A	C1
R 1283	CHIP RES.	22	1/16W	5%	RMC1/16S 220JTH	J24189005		1-	B	c2
R 1284	CHIP RES.	10k	1/16W	5%	RMC1/16S 103JTH	J24189037		1-	B	e2
R 1286	CHIP RES.	3.3k	1/16W	5%	RMC1/16S 332JTH	J24189031		1-	B	c3
R 1287	CHIP RES.	1k	1/16W	5%	RMC1/16S 102JTH	J24189025		1-	A	C3
R 1288	CHIP RES.	10k	1/16W	5%	RMC1/16S 103JTH	J24189037		1-	A	D1
R 1289	CHIP RES.	1k	1/16W	5%	RMC1/16S 102JTH	J24189025		1-	A	C1
R 1290	CHIP RES.	4.7k	1/16W	5%	RMC1/16S 472JTH	J24189033		1-	B	e2
R 1291	CHIP RES.	3.3k	1/16W	5%	RMC1/16S 332JTH	J24189031		1-	B	e2
R 1293	CHIP RES.	270k	1/16W	5%	RMC1/16S 274JTH	J24189054		1-	B	d1
R 1294	CHIP RES.	100k	1/16W	5%	RMC1/16S 104JTH	J24189049		1-	B	a2
R 1295	CHIP RES.	3.3k	1/16W	5%	RMC1/16S 332JTH	J24189031		1-	B	c2
R 1296	CHIP RES.	8.2k	1/16W	5%	RMC1/16S 822JTH	J24189036		1-	B	c2
R 1297	CHIP RES.	180	1/16W	5%	RMC1/16S 181JTH	J24189016	W/LCD	1-	B	d3
R 1298	CHIP RES.	180	1/16W	5%	RMC1/16S 181JTH	J24189016	W/LCD	1-	B	d3
R 1301	CHIP RES.	0	1/16W	5%	RMC1/16S JPTH	J24189070		1-	A	D2
R 1302	CHIP RES.	4.7k	1/16W	5%	RMC1/16S 472JTH	J24189033		1-	B	e1
R 1303	CHIP RES.	0	1/16W	5%	RMC1/16S JPTH	J24189070		1-	B	e1
R 1304	CHIP RES.	0	1/16W	5%	RMC1/16S JPTH	J24189070		1-		
S 1002	ROTARY SWITCH				TP70TF5161	N0190183		1-	B	a2
S 1003	TACT SWITCH				SKRTLAE010	N5090130		1-	B	a1

MAIN Unit

REF.	DESCRIPTION	VALUE	V/W	TOL.	MFR'S DESIG	VXSTD P/N	VERS.	LOT.	SIDE	LAY ADR
S 1004	TACT SWITCH				SKRTLAE010	N5090130		1-	B	b1
S 1005	TACT SWITCH				SKRTLAE010	N5090130		1-	B	c1
TH1001	THERMISTOR				TBPS1R103K440H5Q	G9090067		1-	A	D2
TH1002	THERMISTOR				ERTJ0EV473J	G9090120		1-	A	C2
VR1001	POT.				TP76N00N 20KA/SW RY-7513	J60800269		1-	B	a3
X 1001	XTAL SX-1319	7.3728MHz			7.3728MHZ	H0103275		1-	A	C3
X 1002	TCXO	16.8MHz			TTS05VS-M1 16.8MHZ	H9500830		1-	B	d2
XF1001	XTAL FILTER				MFT50.85P2 50.85MHZ	H1102364		1-	B	b2
	LCD HOLDER					RA0546600	W/LCD	1-		
	INTER CONNECTOR					RA0546800	W/LCD	1-		
	TERMINAL PLATE R					RA010700A		1-		
	TERMINAL HOLDER					RA010340B		1-		
	LIGHT GUIDE				(LCD)	RA0546700	W/LCD	1-		
	REFLECTOR SHEET					RA0546900	W/LCD	1-		
	SHIELD CASE VCO					RA0208100		1-		

DUMMY Unit

Circuit Diagram

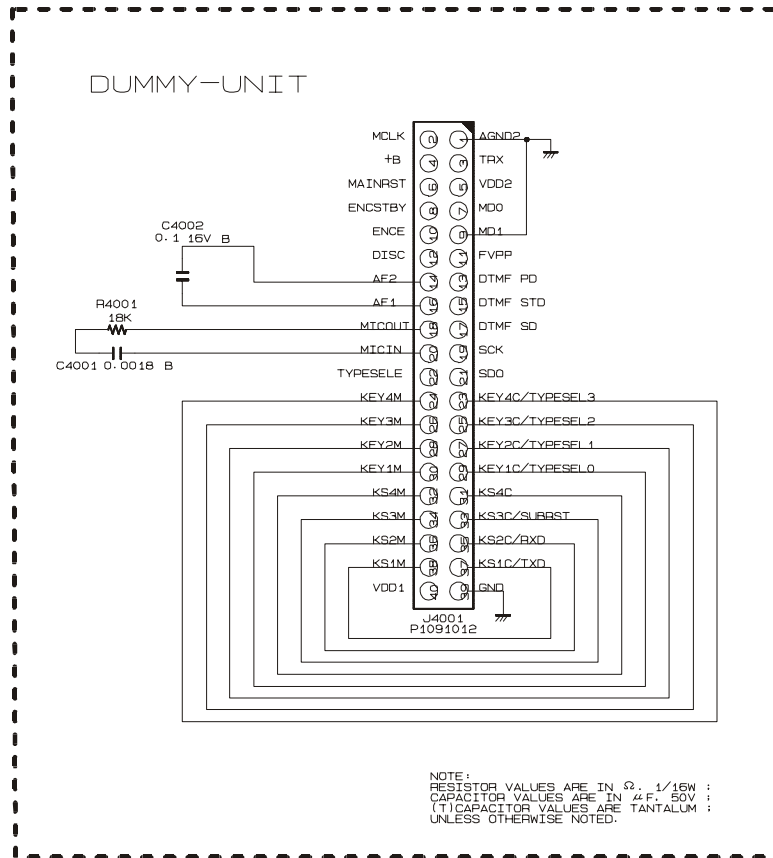

Parts Layout

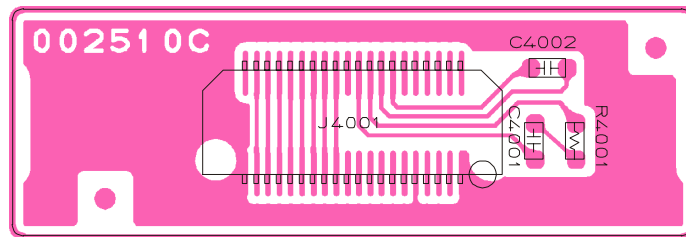

Parts List

REF.	DESCRIPTION	VALUE	V/W	TOL.	MFR'S DESIG	VXSTD P/N	VERS.	LOT.	SIDE	LAY ADR
PCB with Components						CB2731001				
Printed Circuit Board						FR002510C		1-		
C 4001	CHIP CAP.	0.0018uF	50V	B	GRM39B182M50PT	K22174812		1-		
C 4002	CHIP CAP.	0.1uF	16V	B	GRM39B104K16PT	K22124805		1-		
J 4001	CONNECTOR				AXK5S40035P	P1091012		1-		
R 4001	CHIP RES.	18k	1/16W	5%	RMC1/16 183JATP	J24185183		1-		

FVP-25 Encryption / DTMF Pager Unit

Circuit Diagram

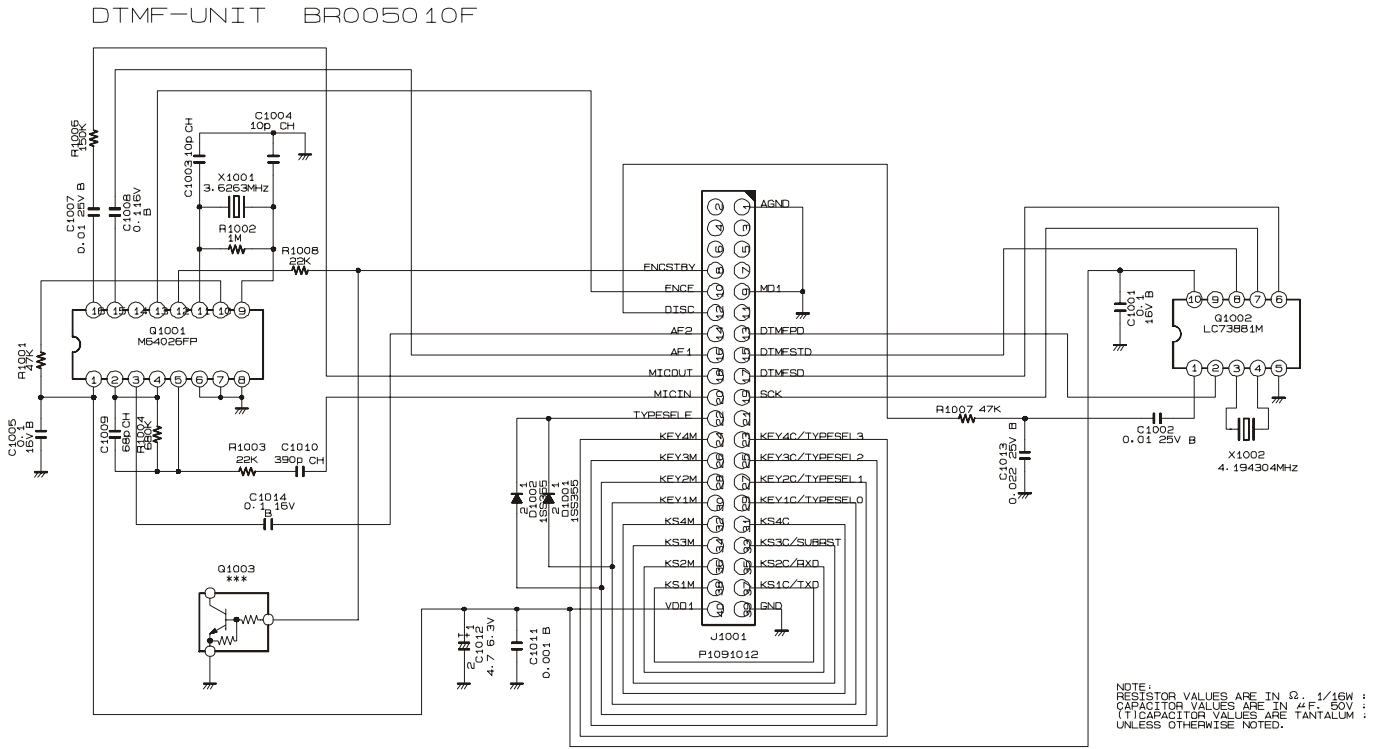

Parts Layout

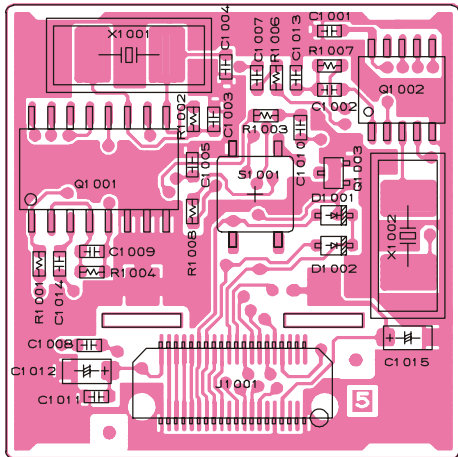

Side A

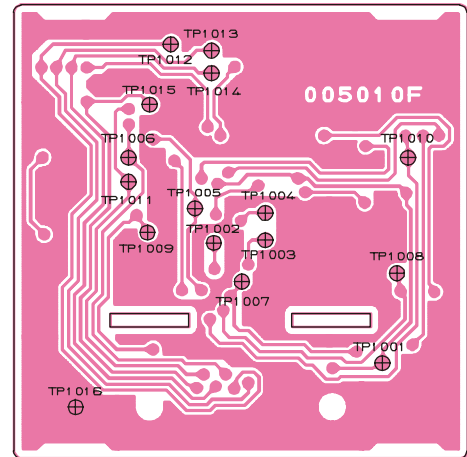

Side B

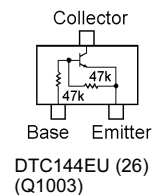
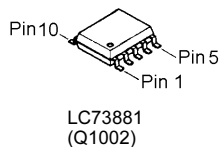
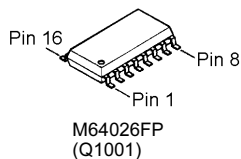

FVP-25 Encryption / DTMF Pager Unit

Parts List

REF.	DESCRIPTION	VALUE	V/W	TOL.	MFR'S DESIG	VXSTD P/N	VERS.	LOT.	SIDE	LAY ADR
*** FVP-25 ***										
Printed Circuit Board						FR005010F		1-		
C 1001	CHIP CAP.	0.1uF	16V	B	GRM39B104K16PT	K22124805		1-	A	B1
C 1002	CHIP CAP.	0.01uF	25V	B	GRM39B103M25PT	K22144802		1-	A	B1
C 1003	CHIP CAP.	10pF	50V	CH	GRM39CH100D50PT	K22174211		1-	A	A1
C 1004	CHIP CAP.	10pF	50V	CH	GRM39CH100D50PT	K22174211		1-	A	A1
C 1005	CHIP CAP.	0.1uF	16V	B	GRM39B104K16PT	K22124805		1-	A	A1
C 1007	CHIP CAP.	0.1uF	16V	B	GRM39B104K16PT	K22124805		1-	A	A1
C 1007	CHIP CAP.	0.01uF	25V	B	GRM39B103M25PT	K22144802		32-	A	A1
C 1008	CHIP CAP.	0.1uF	16V	B	GRM39B104K16PT	K22124805		1-	A	A2
C 1009	CHIP CAP.	68pF	50V	CH	GRM39CH680J50PT	K22174231		1-	A	A1
C 1010	CHIP CAP.	390pF	50V	CH	GRM39CH391J50PT	K22174255		1-	A	A1
C 1011	CHIP CAP.	0.001uF	50V	B	GRM39B102K50PT	K22174821		1-	A	A2
C 1012	CHIP TA.CAP.	4.7uF	6.3V		TEMSVA0J475M-8R	K78080017		1-	A	A2
C 1013	CHIP CAP.	0.022uF	25V	B	GRM39B223K25PT	K22144807		1-	A	A1
C 1014	CHIP CAP.	0.1uF	16V	B	GRM39B104K16PT	K22124805		1-	A	A1
D 1001	DIODE				1SS355 TE-17	G2070470		1-	A	B1
D 1002	DIODE				1SS355 TE-17	G2070470		1-	A	B1
J 1001	CONNECTOR				AXK5S40035P	P1091012		1-	A	A2
Q 1001	IC				M64026FP-650C	G1092754		1-	A	A1
Q 1002	IC				LC73881M-TLM	G1092755		1-	A	B1
Q 1003	TRANSISTOR				DTC144EU T106	G3070041		1-	A	B1
R 1001	CHIP RES.	47k	1/16W	5%	RMC1/16 473JATP	J24185473		1-	A	A1
R 1002	CHIP RES.	1M	1/16W	5%	RMC1/16 105JATP	J24185105		1-	A	A1
R 1003	CHIP RES.	22k	1/16W	5%	RMC1/16 223JATP	J24185223		1-	A	A1
R 1004	CHIP RES.	680k	1/16W	5%	RMC1/16 684JATP	J24185684		1-	A	A1
R 1006	CHIP RES.	150k	1/16W	5%	RMC1/16 154JATP	J24185154		1-	A	A1
R 1007	CHIP RES.	47k	1/16W	5%	RMC1/16 473JATP	J24185473		1-	A	B1
R 1008	CHIP RES.	10k	1/16W	5%	RMC1/16 103JATP	J24185103		1-	A	A1
R 1008	CARBON FILM RES.	22k	1/8W	5%	RD18TJ223 22K	J01215223		14-	A	A1
R 1008	CHIP RES.	22k	1/16W	5%	RMC1/16 223JATP	J24185223		17-	A	A1
X 1001	XTAL SX-1315	3.6263MHz			3.6263MHZ	H0103183		1-	A	A1
X 1002	XTAL SX-1315	4.194304MHz			4.194304MHZ	H0103184		1-	A	B1
	BLIND SHEET					RA0109300		1-		

Circuit Diagram

VX-TRUNK-UNIT BR002540C

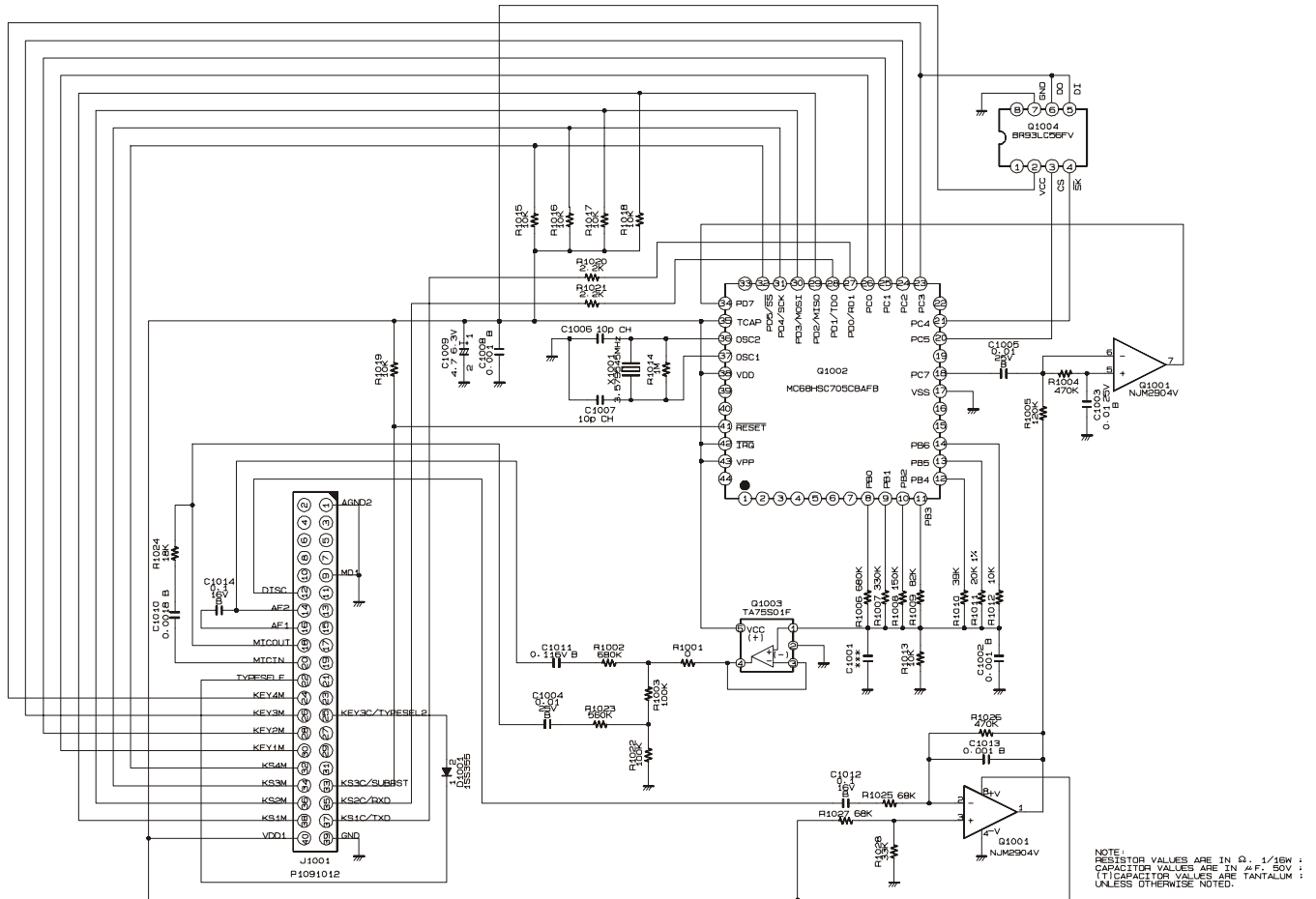

Parts Layout

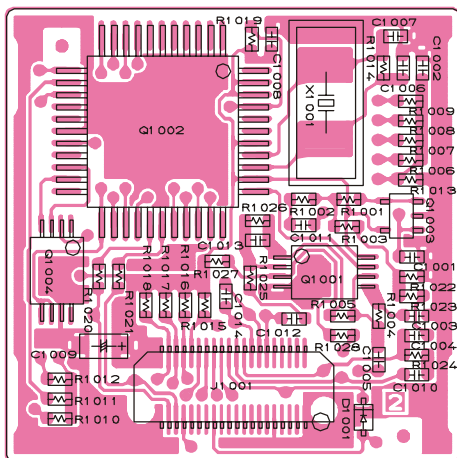

Side A

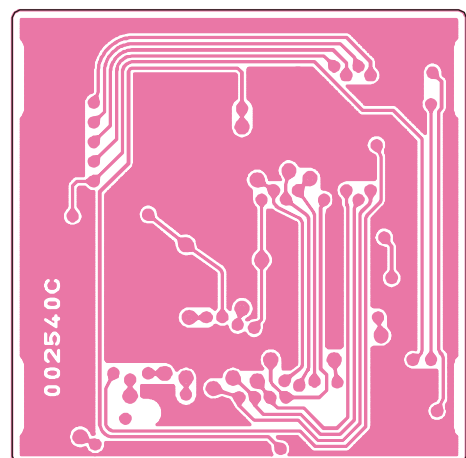

Side B

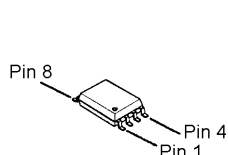

NJM2904V
(Q1001)

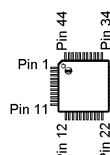

MC68HSC705C8A502
(Q1002)

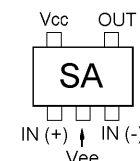

TA75S01F (SA)
(Q1003)

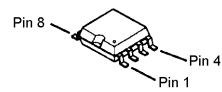

BR93LC56FV
(Q1004)

VTP-50 VX-Trunk Unit

Parts List

REF.	DESCRIPTION	VALUE	V/W	TOL.	MFR'S DESIG	VXSTD P/N	VERS.	LOT.	SIDE	LAY ADR
*** VTP-50 ***										
Printed Circuit Board						FR002540C		1-		
C 1002	CHIP CAP.	0.001uF	50V	B	GRM39B102K50PT	K22174821		1-	A	
C 1003	CHIP CAP.	0.01uF	25V	B	GRM39B103M25PT	K22144802		1-	A	
C 1003	CHIP CAP.	0.01uF	25V	B	GRM39B103K25PT	K22144803		9-	A	
C 1004	CHIP CAP.	0.1uF	16V	B	GRM39B104K16PT	K22124805		1-	A	
C 1004	CHIP CAP.	0.01uF	25V	B	GRM39B103K25PT	K22144803		9-	A	
C 1005	CHIP CAP.	0.01uF	25V	B	GRM39B103M25PT	K22144802		1-	A	
C 1005	CHIP CAP.	0.01uF	25V	B	GRM39B103K25PT	K22144803		9-	A	
C 1006	CHIP CAP.	10pF	50V	CH	GRM39CH100C50PT	K22174248		1-	A	
C 1007	CHIP CAP.	10pF	50V	CH	GRM39CH100C50PT	K22174248		1-	A	
C 1008	CHIP CAP.	0.001uF	50V	B	GRM39B102K50PT	K22174821		1-	A	
C 1009	CHIP TA.CAP.	4.7uF	6.3V		TEMSVA0J475M-8R	K78080017		1-	A	
C 1010	CHIP CAP.	0.0018uF	50V	B	GRM39B182M50PT	K22174812		1-	A	
C 1011	CHIP CAP.	0.1uF	16V	B	GRM39B104K16PT	K22124805		1-	A	
C 1012	CHIP CAP.	0.1uF	16V	B	GRM39B104K16PT	K22124805		1-	A	
C 1013	CHIP CAP.	0.001uF	50V	B	GRM39B102K50PT	K22174821		1-	A	
C 1014	CHIP CAP.	0.1uF	16V	B	GRM39B104K16PT	K22124805		1-	A	
D 1001	DIODE				1SS355 TE-17	G2070470		1-	A	
J 1001	CONNECTOR				AXK5S40035P	P1091012		1-	A	
Q 1001	IC				NJM2904V-TE1	G1091677		1-	A	
Q 1002	IC				MC68HSC705C8A502-6030 130	G1092917		1-	A	
Q 1002	IC				MC68HSC705C8A502-6030 131	G1093326		6-	A	
Q 1003	IC				TA75S01F TE85R	G1091593		1-	A	
Q 1004	IC				BR93LC56FV-E2	G1092787		1-	A	
R 1001	CHIP RES.	0	1/16W	5%	RMC1/16 000JATP	J24185000		1-	A	
R 1002	CHIP RES.	680k	1/16W	5%	RMC1/16 684JATP	J24185684		1-	A	
R 1003	CHIP RES.	100k	1/16W	5%	RMC1/16 104JATP	J24185104		1-	A	
R 1004	CHIP RES.	470k	1/16W	5%	RMC1/16 474JATP	J24185474		1-	A	
R 1005	CHIP RES.	120k	1/16W	5%	RMC1/16 124JATP	J24185124		1-	A	
R 1006	CHIP RES.	680k	1/16W	5%	RMC1/16 684JATP	J24185684		1-	A	
R 1007	CHIP RES.	330k	1/16W	5%	RMC1/16 334JATP	J24185334		1-	A	
R 1008	CHIP RES.	150k	1/16W	5%	RMC1/16 154JATP	J24185154		1-	A	
R 1009	CHIP RES.	82k	1/16W	5%	RMC1/16 823JATP	J24185823		1-	A	
R 1010	CHIP RES.	39k	1/16W	5%	RMC1/16 393JATP	J24185393		1-	A	
R 1011	CHIP RES.	20k	1/16W	1%	RMC1/16 203FTP	J24183203		1-	A	
R 1012	CHIP RES.	10k	1/16W	5%	RMC1/16 103JATP	J24185103		1-	A	
R 1013	CHIP RES.	10k	1/16W	5%	RMC1/16 103JATP	J24185103		1-	A	
R 1014	CHIP RES.	1M	1/16W	5%	RMC1/16 105JATP	J24185105		1-	A	
R 1015	CHIP RES.	10k	1/16W	5%	RMC1/16 103JATP	J24185103		1-	A	
R 1016	CHIP RES.	10k	1/16W	5%	RMC1/16 103JATP	J24185103		1-	A	
R 1017	CHIP RES.	10k	1/16W	5%	RMC1/16 103JATP	J24185103		1-	A	
R 1018	CHIP RES.	10k	1/16W	5%	RMC1/16 103JATP	J24185103		1-	A	
R 1019	CHIP RES.	10k	1/16W	5%	RMC1/16 103JATP	J24185103		1-	A	
R 1020	CHIP RES.	2.2k	1/16W	5%	RMC1/16 222JATP	J24185222		1-	A	
R 1021	CHIP RES.	2.2k	1/16W	5%	RMC1/16 222JATP	J24185222		1-	A	
R 1022	CHIP RES.	100k	1/16W	5%	RMC1/16 104JATP	J24185104		1-	A	
R 1023	CHIP RES.	560k	1/16W	5%	RMC1/16 564JATP	J24185564		1-	A	
R 1024	CHIP RES.	18k	1/16W	5%	RMC1/16 183JATP	J24185183		1-	A	
R 1025	CHIP RES.	68k	1/16W	5%	RMC1/16 683JATP	J24185683		1-	A	
R 1026	CHIP RES.	470k	1/16W	5%	RMC1/16 474JATP	J24185474		1-	A	
R 1027	CHIP RES.	68k	1/16W	5%	RMC1/16 683JATP	J24185683		1-	A	
R 1028	CHIP RES.	33k	1/16W	5%	RMC1/16 333JATP	J24185333		1-	A	
X 1001	XTAL SX-1315	3.579545MHZ			3.579545MHZ	H0103185		1-	A	
	BLIND SHEET					RA0109300		1-		

DVS-5 Voice Storage Unit

Circuit Diagram

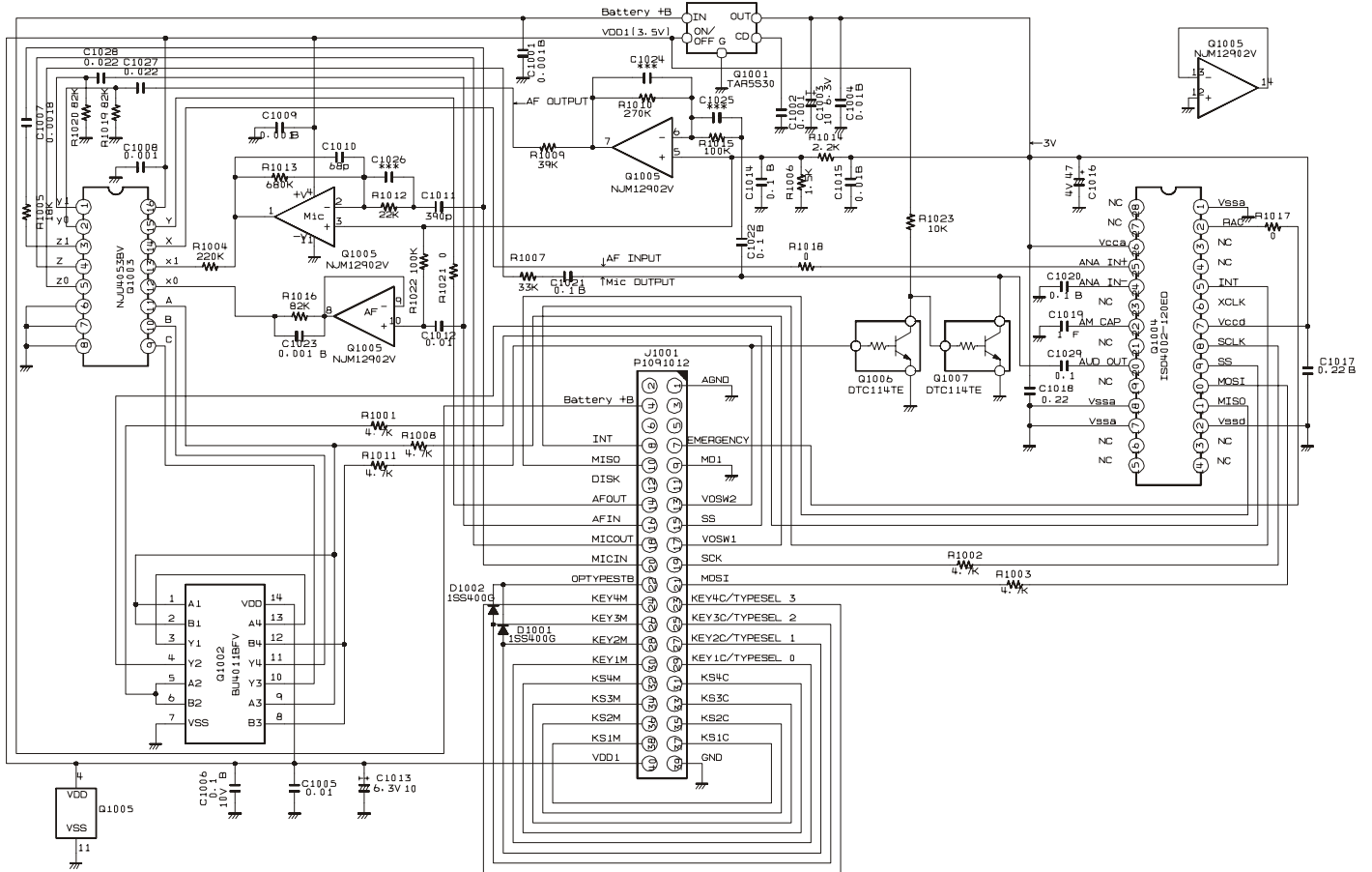

Parts Layout

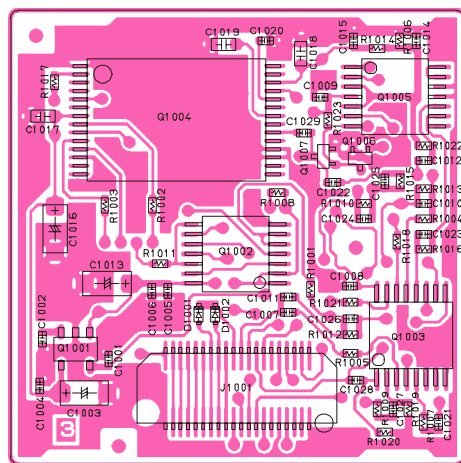

Side A

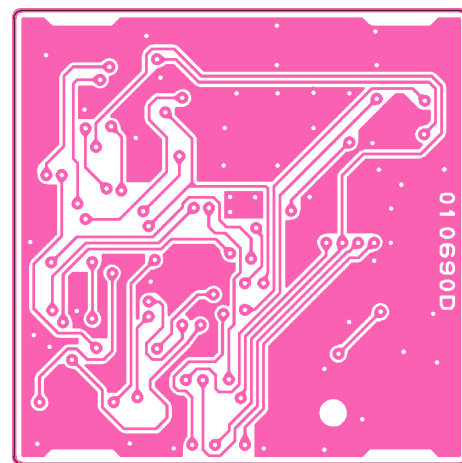

Side B

DVS-5 Voice Storage Unit

Parts List

REF.	DESCRIPTION	VALUE	V/W	TOL.	MFR'S DESIG	VXSTD P/N	VERS.	LOT.	SIDE	LAY ADR
*** DVS-5 ***										
Printed Circuit Board						FR010690D		1-		
C 1001	CHIP CAP.	0.001uF	50V	B	GRM36B102K50PT	K22178809		1-	A	
C 1002	CHIP CAP.	0.001uF	50V	B	GRM36B102K50PT	K22178809		1-	A	
C 1003	CHIP TA.CAP.	10uF	6.3V		TEMSVA0J106M-8R	K78080027		1-	A	
C 1004	CHIP CAP.	0.01uF	16V	B	GRM36B103K16PT	K22128804		1-	A	
C 1005	CHIP CAP.	0.01uF	16V	B	GRM36B103K16PT	K22128804		1-	A	
C 1006	CHIP CAP.	0.1uF	10V	B	GRM36B104K10PT	K22108802		1-	A	
C 1007	CHIP CAP.	0.0018uF	50V	B	GRM36B182K50PT	K22178812		1-	A	
C 1008	CHIP CAP.	0.001uF	50V	B	GRM36B102K50PT	K22178809		1-	A	
C 1009	CHIP CAP.	0.001uF	50V	B	GRM36B102K50PT	K22178809		1-	A	
C 1010	CHIP CAP.	68pF	50V	CH	GRM36CH680J50PT	K22178232		1-	A	
C 1011	CHIP CAP.	390pF	50V	B	GRM36B391K50PT	K22178804		1-	A	
C 1012	CHIP CAP.	0.01uF	16V	B	GRM36B103K16PT	K22128804		1-	A	
C 1013	CHIP TA.CAP.	10uF	6.3V		TEMSVA0J106M-8R	K78080027		1-	A	
C 1014	CHIP CAP.	0.1uF	10V	B	GRM36B104K10PT	K22108802		1-	A	
C 1015	CHIP CAP.	0.01uF	16V	B	GRM36B103K16PT	K22128804		1-	A	
C 1016	CHIP TA.CAP.	47uF	4V		SK7-0G476M-RA	K78060048		1-	A	
C 1017	CHIP CAP.	0.22uF	10V	B	GRM39B224K10PT	K22104801		1-	A	
C 1018	CHIP CAP.	0.22uF	10V	B	GRM39B224K10PT	K22104801		1-	A	
C 1019	CHIP CAP.	1uF	10V	F	GRM39F105Z10PT	K22105001		1-	A	
C 1020	CHIP CAP.	0.1uF	10V	B	GRM36B104K10PT	K22108802		1-	A	
C 1021	CHIP CAP.	0.1uF	10V	B	GRM36B104K10PT	K22108802		1-	A	
C 1022	CHIP CAP.	0.1uF	10V	B	GRM36B104K10PT	K22108802		1-	A	
C 1023	CHIP CAP.	0.001uF	50V	B	GRM36B102K50PT	K22178809		1-	A	
C 1027	CHIP CAP.	0.022uF	16V	B	GRM36B223K16PT	K22128806		1-	A	
C 1028	CHIP CAP.	0.022uF	16V	B	GRM36B223K16PT	K22128806		1-	A	
C 1029	CHIP CAP.	0.1uF	10V	B	GRM36B104K10PT	K22108802		1-	A	
D 1001	DIODE				1SS400G T2R	G2070934		1-	A	
D 1002	DIODE				1SS400G T2R	G2070934		1-	A	
J 1001	CONNECTOR				AXK5S40035P	P1091012		1-	A	
Q 1001	IC				TAR5S30(TE85L)	G1093570		1-	A	
Q 1002	IC				BU4011BFV-E2	G1093551		1-	A	
Q 1003	IC				NJU4053BV-TE1	G1092927		1-	A	
Q 1004	IC				ISD4002-120ED	G1093898		1-	A	
Q 1005	IC				NJM12902V(TE1)	G1093592		1-	A	
Q 1006	TRANSISTOR				DTC114TE TL	G3070225		1-	A	
Q 1007	TRANSISTOR				DTC114TE TL	G3070225		1-	A	
R 1001	CHIP RES.	4.7k	1/16W	5%	RMC1/16S 472JTH	J24189033		1-	A	
R 1002	CHIP RES.	4.7k	1/16W	5%	RMC1/16S 472JTH	J24189033		1-	A	
R 1003	CHIP RES.	4.7k	1/16W	5%	RMC1/16S 472JTH	J24189033		1-	A	
R 1004	CHIP RES.	220k	1/16W	5%	RMC1/16S 224JTH	J24189053		1-	A	
R 1005	CHIP RES.	18k	1/16W	5%	RMC1/16S 183JTH	J24189040		1-	A	
R 1006	CHIP RES.	1.5k	1/16W	5%	RMC1/16S 152JTH	J24189027		1-	A	
R 1007	CHIP RES.	33k	1/16W	5%	RMC1/16S 333JTH	J24189043		1-	A	
R 1008	CHIP RES.	4.7k	1/16W	5%	RMC1/16S 472JTH	J24189033		1-	A	
R 1009	CHIP RES.	39k	1/16W	5%	RMC1/16S 393JTH	J24189044		1-	A	
R 1010	CHIP RES.	270k	1/16W	5%	RMC1/16S 274JTH	J24189054		1-	A	
R 1011	CHIP RES.	4.7k	1/16W	5%	RMC1/16S 472JTH	J24189033		1-	A	
R 1012	CHIP RES.	22k	1/16W	5%	RMC1/16S 223JTH	J24189041		1-	A	
R 1013	CHIP RES.	680k	1/16W	5%	RMC1/16S 684JTH	J24189059		1-	A	
R 1014	CHIP RES.	2.2k	1/16W	5%	RMC1/16S 222JTH	J24189029		1-	A	
R 1015	CHIP RES.	100k	1/16W	5%	RMC1/16S 104JTH	J24189049		1-	A	
R 1016	CHIP RES.	82k	1/16W	5%	RMC1/16S 823JTH	J24189048		1-	A	
R 1017	CHIP RES.	0	1/16W	5%	RMC1/16S JPTH	J24189070		1-	A	
R 1018	CHIP RES.	0	1/16W	5%	RMC1/16S JPTH	J24189070		1-	A	
R 1019	CHIP RES.	82k	1/16W	5%	RMC1/16S 823JTH	J24189048		1-	A	
R 1020	CHIP RES.	82k	1/16W	5%	RMC1/16S 823JTH	J24189048		1-	A	
R 1021	CHIP RES.	0	1/16W	5%	RMC1/16S JPTH	J24189070		1-	A	
R 1022	CHIP RES.	100k	1/16W	5%	RMC1/16S 104JTH	J24189049		1-	A	
R 1023	CHIP RES.	10k	1/16W	5%	RMC1/16S 103JTH	J24189037		1-	A	



Copyright 2004
VERTEX STANDARD CO., LTD.
All rights reserved

No portion of this manual
may be reproduced without
the permission of
VERTEX STANDARD CO., LTD.



E C O 5 0 N 9 0 A