

Courtesy of <http://BlackRadios.terryo.org>

**INSTALLATION, OPERATION, AND
INTERMEDIATE LEVEL MAINTENANCE MANUAL
FOR THE
WJ-8711A DIGITAL HF RECEIVER**

P/ N 181126-001, Revision Z

**Copyright © DRS Signal Solutions, Inc. 1995
All Rights Reserved**

**DRS Technologies
DRS Signal Solutions, Inc.
700 Quince Orchard Road
Gaithersburg, Maryland 20878-1794**

March 2007

PROPRIETARY STATEMENT

This document and subject matter disclosed herein are proprietary items to which DRS Signal Solutions, Inc. retains the exclusive right of dissemination, reproduction, manufacture and sale.

This document is provided to the individual or using organization for their use alone in the direct support of the associated equipment unless permission for further disclosure is expressly granted in writing.

WARRANTY

Seller warrants for a period of one year from the date of shipment, unless a different period has been agreed upon and incorporated into the Contract, that the products delivered or services rendered will conform to the specifications and be free from defects in workmanship and materials. THE FOREGOING WARRANTIES ARE EXCLUSIVE AND IN LIEU OF ALL OTHER WARRANTIES OF MERCHANTABILITY, FITNESS FOR PURPOSE, OR OTHER WARRANTIES OR GUARANTIES OF ANY KIND OR DESCRIPTION, WHETHER STATUTORY, EXPRESS, OR IMPLIED. If the goods delivered or services performed fail to conform to the warranty stated in this clause, Seller will correct the nonconformity at its expense by such repair, adjustment, modification, or replacement of the goods or services as Seller deems expedient. THE FOREGOING REMEDY OF BUYER FOR ANY FAILURE OF THE GOODS OR SERVICES TO MEET ANY WARRANTY IS EXCLUSIVE. BUYER EXPRESSLY AGREES THAT THE LIABILITY OF SELLER UNDER ANY WARRANTY SHALL NOT INCLUDE DAMAGE TO OR LOSS OF PROPERTY OTHER THAN THE GOODS COVERED BY THE CONTRACT; LOSS OF PROFITS OR REVENUE; INCREASED COSTS OF ANY KIND; CLAIMS OF CUSTOMERS OF BUYER; OR ANY INDIRECT, SPECIAL, INCIDENTAL, OR CONSEQUENTIAL DAMAGES. As to goods or components where the customer has funded the repair, Seller will warrant as limited above, the repaired portion of the unit for three months from the date of reshipment. EQUIPMENT OR PARTS DESCRIBED AS BEING MANUFACTURED BY OTHERS ARE SOLD BY SELLER AS IS and Buyer must look to the respective manufacturer for any and all claims with regard to said equipment or parts.

WARNING

This unit contains a RAM Integrated Circuit (A2U5) that includes an on-board lithium source used as back up power for memory retention. Extreme care should be used in storage, handling, and disposal of parts having lithium content. Improper handling may present explosion hazard. If the Digital Assembly is to be disposed, remove the RAM IC. If replacement of the IC is required, carefully insert a blunt, nonmetallic, tool between the bottom face of the IC and the related socket. Pry the IC up at a slight angle and remove with fingers.

- Wear eye protection when handling component with lithium content.
- Do not puncture, compact, incinerate, short circuit, or expose the lithium energy source to temperatures above 176°F (80°C).
- Do not store ICs with lithium content loose in bins. Store original containers.
- Dispose of ICs with lithium content properly. Discharged cells should be handled with care, as they retain significant energy. They should be electrically isolated and packaged for disposal. Dispose in accordance with local regulations for hazardous material disposal. DO NOT INCINERATE OR COMPACT.
- Refer to **Figure 7-23** for location of RAM IC (A2U5) on the Digital Assembly (A2).

THIS PAGE INTENTIONALLY LEFT BLANK



THEN... WRITE DOWN THE INFORMATION ABOUT IT ON THIS FORM. TEAR IT OUT AND FAX IT TO:
1-301-921-9479 OR
E-MAIL US AT
customer.help@drs-ss.com

SOMETHING WRONG WITH THIS PUBLICATION ?

FROM: (PRINT YOUR COMPLETE ADDRESS)

DATE SENT

PUBLICATION PART NO.

REVISION LEVEL

PUBLICATION TITLE

PIN POINT THE PROBLEM

IN THIS SPACE TELL WHAT IS WRONG AND WHAT SHOULD BE DONE ABOUT IT:

PAGE NO.	PARA-GRAPH	FIGURE NO.	TABLE NO.
----------	------------	------------	-----------

TEAR OUT AND FAX: 1-301-921-9479

Courtesy of <http://BlackRadios.terryo.org>

THIS PAGE INTENTIONALLY LEFT BLANK

LIST OF EFFECTIVE PAGES

<u>Page Number</u>	<u>Description</u>	<u>Revision</u>
i	Cover	Z
ii	Proprietary Statement	R
iii	Warnings	R
iv	Intentionally Blank	R
A	Customer Feedback Form	R
B	Intentionally Blank	S
v	List of Effective Pages	Z
vi	List of Effective Pages	Y
vii	Revision Record	Z
viii	Declaration of Conformity	R
ix	Table of Contents	T
x thru xii	Table of Contents	V
xiii thru xv	Table of Contents	T
xvi	Table of Contents	V
xvii	Table of Contents	T
xviii	Table of Contents	R
1-i	Section Cover	R
1-0	Illustration	S
1-1 thru 1-3	Section One	S
1-4	Section One	Y
1-5 thru 1-6	Section One	S
1-7	Section One	U
1-8 thru 1-12	Section One	S
2-i	Section Cover	R
2-0	Illustration	R
2-1 thru 2-4	Section Two	R
2-5 thru 2-8	Section Two	T
2-9 thru 2-11	Section Two	Z
2-12 thru 2-14	Section Two	R
3-i	Section Cover	R
3-ii	Intentionally Blank	R
3-1 thru 3-11	Section Three	R
3-12	Section Three	V
3-13 thru 3-14	Section Three	R
3-15 thru 3-50	Section Three	V
4-i	Section Cover	R
4-ii	Intentionally Blank	R
4-1 thru 4-28	Section Four	R
5-i	Section Cover	R
5-ii	Intentionally Blank	R
5-1	Section Five	R
5-2 thru 5-18	Section Five	R
6-i	Section Cover	S
6-0	Illustration	V
6-1 thru 6-14	Section Six	S

LIST OF EFFECTIVE PAGES (Continued)

<u>Page Number</u>	<u>Description</u>	<u>Revision</u>
7-i	Section Cover	S
7-ii	Intentionally Blank	S
7-1 thru 7-23	Section Seven	S
7-24 thru 7-26	Section Seven	V
7-27 thru 7-30	Section Seven	V
8-i	Section Cover	S
8-ii	Intentionally Blank	S
8-1 thru 8-6	Section Eight	S
8-7	Section Eight	W
8-8 thru 8-72	Section Eight	S
FP-i	Section Cover	R
FP-ii	Intentionally Blank	R
FP-1/ (FP-2 blank)	Fold outs	R
FP-3/ (FP-4 blank)	Fold outs	R
FP-5/ (FP-6 blank)	Fold outs	R
FP-7/ (FP-8 blank)	Fold outs	R
FP-9/ (FP-10 blank)	Fold outs	R
FP-11/ (FP-12 blank)	Fold outs	R
FP-13/ (FP-14 blank)	Fold outs	R
FP-15/ (FP-16 blank)	Fold outs	S
FP-17/ (FP-18 blank)	Fold outs	S
FP-19/ (FP-20 blank)	Fold outs	S
FP-21/ (FP-22 blank)	Fold outs	S
FP-23/ (FP-24 blank)	Fold outs	S
FP-25/ (FP-26 blank)	Fold outs	S
FP-27/ (FP-28 blank)	Fold outs	S
FP-29/ (FP-30 blank)	Fold outs	S
FP-31/ (FP-32 blank)	Fold outs	S
FP-33/ (FP-34 blank)	Fold outs	S
FP-35/ (FP-36 blank)	Fold outs	S
FP-37/ (FP-38 blank)	Fold outs	S
FP-39/ (FP-40 blank)	Fold outs	S
FP-41/ (FP-42 blank)	Fold outs	S
FP-43/ (FP-44 blank)	Fold outs	S
FP-45/ (FP-46 blank)	Fold outs	S

Insert Appendix A Type WJ871Y/REF Reference Generator Option (P/N 181280-001)

Insert Appendix B Type WJ8711/PRE Suboctave Preselector Option (P/N 181281-001)

Insert Appendix C WJ8711A/COR Carrier-Operated Relay Option (P/N 181282-001)

Insert Appendix D Type WJ8710/DS01, WJ8711/DS01, and

WJ8712/DS01 Digital Signal Output Options (P/N 181272-001)

Insert Appendix E WJ8711/488 and WJ8712/488 IEEE488 Interface Options (P/N 181283-001)

Insert Appendix F WJ871Y/8KRF 8 kHz Roofing Filter Option (P/N 181284-001)

Insert Appendix H WJ871Y/485 RS-485 Interface Option (P/N 181273-001)

Insert Appendix I Type WJ871Y/SEU Speech Enhancement Unit (P/N 181274-001)

Insert Appendix JWJ871Y/IFC125 12.5 kHz IF Output Option (P/N 181275-001)

Insert Appendix K Type WJ871Y/FSK Frequency Shift Keying Option (P/N 181401-001)

WJ-8711A DIGITAL HF RECEIVER

REVISION RECORD

Revision	Description	Date
A	Initial issue.	11/93
B	Revised specification related to IF bandwidth shape factors.	12/93
C	Provides additional information in Section I concerning COR, DSO1, 488, 8KRF, and PCSM options. Updates software release history. Adds Appendix C for WJ8711A/COR option and Appendix G for WJ8711/PCSM option.	2/94
D	Adds Appendix H for WJ871Y/485 option. Updates Appendix G for WJ71Y/PCSM option.	2/94
E	Provides application information for the Mute Input terminal (TB1 terminal 12).	6/94
F	Provides information on enhancements to the AGC software and on the Synchronous AM (SAM) Detection Mode. Documents updated Digital Assembly (A2).	4/95
G	Updated manual to reflect 871Y Control Version 04.01.05. Added information about use of CIV Level Converter when using CSMA Interface.	11/95
H	Added information requiring the use of a shielded twisted pair cable with the CSMA interface to ensure electromagnetic compatibility with other devices. Added Declaration of Conformity to IEC EMC standards. Also corrected errata. Bit 6 of the Event Summary Status Register is not used. It cannot be set to flag front panel parameter changes. Improved AGC attack time specification from 15 ms to 5 msec.	04/96
I	Eliminated specifications related to environmental test methods and vibration. Eliminated WJ871Y/PCSM2 Personal Computer Signal Monitor Option from list of available options. Added WJ871Y/PCSW freeware program to the equipment supplied list.	7/96
J	Added WJ part number to the title page. Incorporated a List of Effective Pages. Added page numbers to section cover pages and their back pages. Removed "intentionally left blank" pages and replaces with "Notes" pages that are formatted with headers and page numbers.	9/97
K	Incorporated ECO 039216.	11/98
L	Incorporated ECO 039120.	5/99
M	Incorporated ECO 029595.	5/99
N	Incorporated ECO 039674.	6/99
P	Incorporated ECO 039883.	4/00
Q	Incorporated ECO 042507.	11/02
R	Incorporated ECO 044391.	1/04
S	Incorporated ECO 044690.	4/04
T	Incorporated ECO 045084.	7/04
U	Incorporated ECO 045371.	11/04
V	Incorporated ECO 046285.	09/05
W	Incorporated ECO 046323.	10/05
Y	Incorporated ECO 048449. In Table 1-1 changed Local Oscillator Phase Noise from -110 dBc to -103 dBc.	2/07
Z	Incorporated ECO 048664. Updated paragraph 2.2.5 and Figure 2-4 .	3/07

DECLARATION OF CONFORMITY

According to ISO/IEC Guide 22 and EN 45014

MANUFACTURER'S NAME:



WATKINS-JOHNSON COMPANY
Electronic Equipment Division

MANUFACTURER'S ADDRESS:

700 QUINCE ORCHARD ROAD
GAITHERSBURG, MARYLAND 20878-1794
U.S.A.

DECLARES THAT THE PRODUCT

PRODUCT NAME: Digital HF Receiver

MODEL NUMBER: WJ-8711A

CONFORMS TO THE FOLLOWING SPECIFICATIONS AND/OR DIRECTIVES:

SAFETY: IEC 1010-1: 1990 and EN61010-1: 1993 w/Amendment A2:
7/95

EMC: EN50081-1 (Radiated and Conducted Emissions to EN55022,
Class B)
EN50082-1 (Including IEC 801-2: 1984, IEC 801-3: 1984 and
IEC 801-4: 1988)
EN55020 (Immunity for Receivers)

SUPPLEMENTARY INFORMATION:

Directives Compliance: Low Voltage (Safety) 73/23/EEC
EMC 89/336/EEC

AUTHORIZED SIGNATURE

A handwritten signature in black ink, appearing to read 'Barry N. Wright', written over a horizontal line.

BARRY N. WRIGHT
MANAGER, PRODUCT ASSURANCE
AND REGULATORY COMPLIANCE

LOCATION AND DATE OF DECLARATION:

Gaithersburg, Maryland, USA - November 12th, 1996

WATKINS-JOHNSON COMPANY

TABLE OF CONTENTS

WJ-8711A DIGITAL HF RECEIVER

SECTION 1

GENERAL DESCRIPTION

<u>Paragraph</u>		<u>Page</u>
1.1	Electrical Characteristics	1-1
1.2	Mechanical Characteristics	1-6
1.3	Equipment Supplied.....	1-7
1.4	Equipment Required But Not Supplied	1-7
1.5	Receiver Options.....	1-7
1.5.1	WJ8711Y/ REF Reference Generator Option	1-7
1.5.2	WJ8711/ PRE Suboctave Preselector Option.....	1-7
1.5.3	WJ8711A/ COR Carrier-Operated Relay Option	1-7
1.5.4	WJ8711/ DSO 1 Digital Signal Output Option.....	1-8
1.5.5	WJ871Y/ 488 IEEE-488 Interface Option.....	1-8
1.5.6	WJ871Y/ 8KRF 8 kHz Roofing Filter Option	1-8
1.5.7	WJ8711/ SPK Internal Speaker Option	1-8
1.5.8	WJ8711/ BFP Blank Front Panel Option	1-8
1.5.9	WJ871Y/ 485 485 Interface Option	1-8
1.5.10	WJ871Y/ SEU Speech Enhancement Union	1-9
1.5.11	WJ871Y/ IFC 12.5 kHz IF Output Option	1-9
1.5.12	WJ871Y/ FSK Frequency Shift Keying Option.....	1-9
1.6	WJ8711 Software Version Release History.....	1-9
1.6.1	WJ8711A Internal Control Software Release History	1-9
1.6.2	WJ8711A Front Panel Control Software Release History	1-11
1.6.3	WJ8711A DSP Software Release History	1-12

SECTION 2

INSTALLATION

<u>Paragraph</u>		<u>Page</u>
2.1	Unpacking and Inspection.....	2-1
2.2	Installation.....	2-1
2.2.1	Rack Mounting.....	2-1
2.2.2	Mounting Feed for Table Top Operation	2-3
2.2.3	Power Requirements	2-4
2.2.4	Connector Signals.....	2-4
	RF IN, Antenna Input (A3J1)	2-5
	SMO, Signal Monitor Output (A3J2)	2-5
	EXT REF, External Reference Input (A3J3)	2-6
	IF OUT, Post-Filtered IF Output (A2J1)	2-6
	CSMA, Carrier Sense/ Multiple Access Port (A2J2).....	2-6

TABLE OF CONTENTS (Continued)

SECTION II (Continued)

<u>Paragraph</u>		<u>Page</u>
	A2B, RS-232C Serial Interface Port.....	2-7
	TB1, Audio Terminal Block (TB1).....	2-7
	Line Audio Outputs (TB1 Terminals 1 thru 6).....	2-7
	Speaker Output (TB1 Terminals 7 and 8).....	2-7
	DC-Coupled Audio Output (TB1 Terminal 9).....	2-8
	Remote Signal Strength Indicator Output (TB1 Terminal 10).....	2-8
	Squelch Output (TB1 Terminal 11).....	2-8
	Mute Input (TB1 Terminal 12).....	2-8
	POWER, 90-264 VAC Line Power Input (FL1 J1).....	2-8
	PHONES, Front Panel Headphones Jack (A1 J1).....	2-9
	Ground Stud.....	2-9
2.2.5	Configuring the Receiver for Remote Operations.....	2-9
2.3	Equipment Malfunctions.....	2-12
2.4	Preparation for Reshipment or Storage.....	2-13

SECTION 3

LOCAL OPERATION

<u>Paragraph</u>		<u>Page</u>
3.1	Introduction.....	3-1
3.2	Description of Controls, Indicators, and Displays.....	3-1
3.2.1	The Tuned Frequency Display.....	3-2
3.2.2	The Tune Lock Key and Led.....	3-3
3.2.3	The ← (Left) and → (Right) Arrow Keys.....	3-3
3.2.4	The Tuning Wheel.....	3-4
3.2.5	The ↑ (Up) and ↓ (Down) Arrow Keys.....	3-4
3.2.6	The Numeric Entry Keys (0-9 and Decimal Point).....	3-5
3.2.7	The kHz (Kilo hertz) and MHz (Megahertz) Keys.....	3-7
3.2.8	The CE (Clear Entry) Key.....	3-7
3.2.9	The Step Tune Key.....	3-7
3.2.10	The Auxiliary Parameter Displays.....	3-7
3.2.11	The IF BW Key and Led.....	3-8
3.2.12	The DET Mode Key and Led.....	3-9
3.2.13	The Squelch Key and Led.....	3-9
3.2.14	The AGC Key and Led.....	3-9
3.2.15	The BFO Key and Led.....	3-10
3.2.16	The +/- Zero Key.....	3-10
3.2.17	The Blanker Key and Led.....	3-11

TABLE OF CONTENTS (Continued)

SECTION 3 (Continued)

LOCAL OPERATION

<u>Paragraph</u>		<u>Page</u>
3.2.18	The Special Function Key and Led	3-11
	Selecting the Passband Tuning Mode with the SPECIALFUNCTION Key.....	3-12
	Selecting the BITE Initialization Mode with the SPECIALFUNCTION Key	3-13
	Selecting the Remote Control Selection Mode with the SPECIALFUNCTION Key	3-13
	Selecting the Remote Baud Rate Entry Mode with the SPECIALFUNCTION Key	3-13
	Selecting the CSMA Address Mode with the SPECIALFUNCTION Key.....	3-14
	Selecting the IF Bandwidth Select Mode with the SPECIALFunction Key	3-14
	Displaying the Currently Selected Reference Frequency.....	3-15
	Selecting the AGC Threshold Feature.....	3-15
	Selecting the Variable AGC Decay Time Feature	3-16
3.2.19	The Auxiliary Parameter Edit Knob	3-17
3.2.20	The Memory/ Scan Section Alphanumeric Display.....	3-19
3.2.21	The Dwell Key and Led	3-19
3.2.22	The Step Size Key and Led.....	3-19
3.2.23	The Channel View key and Led.....	3-20
3.2.24	The Channel Execute Key and Led.....	3-21
3.2.25	The Scan Type Key and Leds	3-21
3.2.26	The Scan Setup Key and Led	3-21
3.2.27	The Frequency Lockout Key	3-23
3.2.28	The Channel Store Key	3-24
3.2.29	The Clear Key.....	3-24
3.2.30	The Channel Include Key.....	3-25
3.2.31	The Channel Skip Key.....	3-25
3.2.32	The Scan Key and Led	3-26
3.2.33	The Pause Key and Led	3-26
3.2.34	The Memory/ Scan Parameters Edit Knob	3-27
3.2.35	The Phones Output Volume Control Knob	3-28
3.2.26	The Speaker Key and Leds	3-28
3.2.37	The Speaker Output Volume Control Knob	3-28
3.2.38	The RF Input Key	3-29
3.2.39	The Manual Gain Control Knob	3-29
3.2.40	The Signal Level Meter.....	3-29
3.2.41	The Remote Key and Led	3-30
3.2.42	The Power Switch.....	3-30
3.3	Turning on the Receiver.....	3-30
3.3.1	Performing a Cold Start at Power-Up	3-31
3.4	Introduction into Receiver Operations	3-31
3.5	Operation in the Manual Mode	3-32
3.5.1	Entering the Tuned Frequency.....	3-33

TABLE OF CONTENTS (Continued)

SECTION III (Continued)

LOCAL OPERATION

<u>Paragraph</u>		<u>Page</u>
3.5.2	Selecting a Detection Mode.....	3-34
3.5.3	Selecting an IF Bandwidth.....	3-36
	Including an IF Bandwidth Filter for Selection.....	3-36
3.5.4	Setting the Squelch Level.....	3-37
3.5.5	Attenuating or Amplifying Input Signals Via the RF Input Path Selection	3-37
3.5.6	Selecting the Gain Control Mode	3-38
3.5.7	Aiding CW Detection with the BFO Function	3-38
3.5.8	Passband Tuning in CW Detection Mode	3-39
3.5.9	Blanking Out Noise Interference	3-39
3.5.10	Using the Tunable Notch Filter.....	3-40
3.6	Storing Current Receiver Parameters in Memory	3-40
3.7	Changing Receiver Parameters to Those Stored in a Memory Channel.....	3-42
3.8	Operation in the Scan Mode	3-42
3.8.1	Using the Dwell Timer.....	3-43
3.8.2	Scan Setups.....	3-43
	CHANNELScan Setup.....	3-44
	Frequency-to-Frequency (F1 →F2) Scan Setup.....	3-45
	Frequency-to-Frequency with Lockouts (F1 →F2 w/ Lock) Scan Setup	3-46
3.8.3	Placing the Receiver in Scan Mode	3-46
3.8.4	Pausing and Restarting Scans	3-46
3.9	Running the Built-In-Test Function (BITE)	3-47
3.10	Displaying the Receiver's Current Internal Control Software Version.....	3-49
3.11	Setting Remote Operation Configurations from the Front Panel.....	3-49
3.11.1	Selecting the RS-232 or the CSMA Interface for Remote Operations.....	3-49
3.11.2	Selecting the Baud Rate for Remote Operations	3-50
3.11.3	Selecting the Receiver's Address for CSMA Remote Operations.....	3-50

SECTION IV

RS-232 REMOTE OPERATION

<u>Paragraph</u>		<u>Page</u>
4.1	Introduction	4-1
4.2	Interfacing With the WJ8711A	4-2
4.3	Command Message Formatting	4-3
4.3.1	Terminators for Commands and Queries.....	4-3
4.3.2	Formats of Query Responses.....	4-3
4.3.3	Representations of Numeric Arguments.....	4-4

TABLE OF CONTENTS (Continued)

SECTION IV

RS-232 REMOTE OPERATION (Continued)

<u>Paragraph</u>		<u>Page</u>
4.4	Receiver Device Messages	4-5
4.5	Communication Messages.....	4-16
4.6	Receiver Status Summary	4-20
4.6.1	Status Bytes	4-22
4.6.2	Event Summary Status Register.....	4-22
4.6.3	Receiver Status Register	4-23
4.6.4	Device-Dependent Error Register	4-24
4.7	Message Processing	4-25
4.8	RS-232 Communications Protocol.....	4-26
4.8.1	XON/ XOFF Protocol	4-26
4.8.2	ENQ/ ACK Protocol.....	4-27
4.8.3	Buffer Handling.....	4-27
	Input Buffer.....	4-27
	Output Buffer	4-27

SECTION V

CSMA REMOTE CONTROL

<u>Paragraph</u>		<u>Page</u>
5.1	Introduction	5-1
5.2	Controlling Multiple Receivers Via the CSMA Interface	5-1
5.3	Setting Up the Receiver For Remote CSMA Interface.....	5-2
5.4	Electrical Requirements of the Interface	5-3
5.5	Serial Data Transmissions.....	5-4
5.6	Command Message Formatting	5-4
5.7	Control Codes	5-5
5.8	Details on Command and Response Formats	5-7
5.8.1	Tuned Frequency Command Without Acknowledge [00]	5-7
5.8.2	Tuned Frequency Command With Acknowledge [05].....	5-8
5.8.3	Response To Tuned Frequency Requests [03].....	5-9
5.8.4	Response To Tuned Frequency Range Requests [02].....	5-9
5.8.5	Detection Mode/ IF Bandwidth Command Without Acknowledge [01]	5-10
5.8.6	Detection Mode/ IF Bandwidth Command With Acknowledge [06].....	5-11
5.8.7	Response To Detection Mode/ IF Bandwidth Requests [04]	5-11
5.8.8	Gain Control Mode Command With Acknowledge [31].....	5-12

TABLE OF CONTENTS (Continued)

SECTION V

CSMA REMOTE CONTROL (Continued)

<u>Paragraph</u>		<u>Page</u>
5.8.9	Response To Gain Control Mode Requests [30].....	5-13
5.8.10	Manual Gain Level Command With Acknowledge [33].....	5-13
5.8.11	Response To Manual Gain Level Requests [32].....	5-14
5.8.12	BFO Frequency Command With Acknowledge [35].....	5-14
5.8.13	Response To BFO Frequency Requests [34].....	5-15
5.8.14	RF Input Path Command With Acknowledge [39].....	5-15
5.8.15	Response To RF Input Path Requests [38].....	5-16
5.8.16	Device Control Mode Command With Acknowledge [37].....	5-16
5.8.17	Response To Device Control Mode Requests [36].....	5-17
5.9	Collision Detection.....	5-18

SECTION VI

CIRCUIT DESCRIPTION

<u>Paragraph</u>		<u>Page</u>
6.1	WJ8711A Digital HF Receiver Functional Description.....	6-1
6.2	Circuit Descriptions.....	6-3
6.2.1	RF Assembly, (A3).....	6-3
6.2.2	Digital Assembly, (A2).....	6-8
6.2.3	Front Panel Assembly (A1).....	6-12
6.2.4	Power Supply Assembly, (PS1).....	6-14

SECTION VII

MAINTENANCE

<u>Paragraph</u>		<u>Page</u>
7.1	General.....	7-1
7.2	Preventive Maintenance Procedures.....	7-1
7.2.1	Cleaning and Lubrication.....	7-1
7.2.2	Scheduled Preventive Maintenance Procedures.....	7-1
7.3	Inspection for Damage and Wear.....	7-1
7.4	Test Equipment Required.....	7-2
7.5	Troubleshooting and Fault Isolation.....	7-2
7.6	WJ8711A Digital HF Receiver Performance Tests.....	7-2
7.6.1	Power Consumption.....	7-2
7.6.2	Front Panel Tests.....	7-4
7.6.3	Reference Frequency Timebase Accuracy.....	7-5
7.6.4	Fine Tuning Accuracy.....	7-7

TABLE OF CONTENTS (Continued)

SECTION VII (Continued)

MAINTENANCE

<u>Paragraph</u>		<u>Page</u>
7.6.5	Signal Strength Accuracy	7-8
7.6.6	WJ8711A Sensitivity Performance Test	7-9
7.6.7	Audio Distortion Performance Test.....	7-12
7.6.8	Squelch/ Mute Performance Test.....	7-14
7.6.9	Reconstructed IF Output Performance Test.....	7-15
7.6.10	RF/ IF Signal Path Performance Test.....	7-17
7.7	Corrective Maintenance Procedures	7-18
7.7.1	Removing the Receiver Top Cover.....	7-18
7.7.2	Replacing the Receiver Top Cover.....	7-19
7.7.3	Front Panel Assembly (A1) Removal Procedures.....	7-19
7.7.4	Front Panel Assembly (A1) Replacement Procedures.....	7-20
7.7.5	Front Panel PC Assembly (A1A1) Removal Procedures.....	7-21
7.7.6	Front Panel PC Assembly (A1A1) Replacement Procedures.....	7-21
7.7.7	Digital Control PC Assembly (A2) Removal Procedures.....	7-23
7.7.8	Digital Control PC Assembly (A2) Replacement Procedures.....	7-24
7.7.9	RF Tuner Assembly (A3) Removal Procedures.....	7-25
7.7.10	RF Tuner Assembly (A3) Replacement Procedures.....	7-25
7.7.11	Power Supply Assembly (PS1) Removal Procedures.....	7-26
7.7.12	Power Supply Assembly (PS1) Replacement Procedures.....	7-27
7.7.13	Filter/ Power (FL1J1) Removal Procedures.....	7-28
7.7.14	Filter/ Power (FL1J1) Replacement Procedures.....	7-28
7.7.15	Ram/ Battery (A2U5) Removal/ Replacement Procedures.....	7-29

SECTION VIII

REPLACEMENT PARTS LIST

<u>Paragraph</u>		<u>Page</u>
8.1	Unit Numbering Method	8-1
8.2	Reference Designation Prefix	8-1
8.3	Provisioning Note – Inconsistencies In Part Numbering Conventions.....	8-1
8.4	List of Manufacturers.....	8-2
8.5	Parts List.....	8-2
8.6	WJ8711A Digital HF Receiver, Main Chassis.....	8-7
8.6.1	Type 482108-1 Front Panel PC Assembly, A1A1	8-8
8.6.2A	Type 797214-1 Digital Control PC Assembly, A2	8-12
8.6.2B	Type 904978-1 Digital Control PC Assembly, A2	8-31
8.6.3	Type 797006-1 RF Tuner PC Assembly, A3	8-51

TABLE OF CONTENTS (Continued)

FOLDOUTS

<u>Foldout</u>		<u>Page</u>
FO-1	WJ8711A Critical Dimensions Diagram.....	FP-1
FO-2	Front Panel Controls, Indicators and Display.....	FP-3
FO-3	Example of a Channel Scan Operation (3 Sheets).....	FP-5
FO-4	Example of an F1 → F2 Scan Operation with and without Lockouts (2 Sheets).....	FP-11
FO-5	Type 797006-X RF Tuner Assembly (A3), Schematic Diagram 581274 (3 Sheets)	FP-15
FO-6	Type 797214-1 Digital Control Assembly (A2), Schematic Diagram 581839 (4 Sheets)	FP-21
FO-6A	Type 904978-1 Digital Control Assembly (A2) Schematic Diagram 904981 (4 Sheets).....	FP-29
FO-7	Type 482108-1 Front Panel Circuit Card Assembly (A2A1), Schematic Diagram 581267 (2 Sheets).....	FP-37
FO-8	Type WJ8711A Digital HF Receiver, Main Chassis Schematic 581650 (3 Sheets)	FP-41

LIST OF TABLES

<u>Table</u>		<u>Page</u>
1-1	WJ8711A Digital HF Receiver Specifications	1-2
2-1	List of Connectors.....	2-5
3-1	Tunable Notch Filter Range	3-41
3-2	BIIE Error Codes.....	3-47
4-1	Receiver Device Messages	4-5
4-2	Communication Messages.....	4-16
4-3	Status Byte Register, Bit Evaluation	4-20
4-4	Event Summary Status Register, Bit Evaluation.....	4-23
4-5	Receiver Status Register, Bit Evaluation	4-24
4-6	Device-Dependent Error Register, Bit Evaluation	4-25
4-7	Supported RS-232C Communications Control Commands.....	4-26
5-1	CSMA Control Code	5-6
6-1	RF Data Control	6-7
7-1	Required Test Equipment.....	7-3
7-2	Receiver Sensitivity Performance Test Equipment Connection.....	7-10
7-3	Selected IF Bandwidth Frequency Range	7-16

TABLE OF CONTENTS (Continued)

LIST OF ILLUSTRATIONS

<u>Figure</u>		<u>Page</u>
1-1	WJ8711A HF Receiver	1-0
2-1	Installation of Jonathan Type 110QD-16-2 Slide Mounts.....	2-2
2-2	Installing the Mounting Feet for Table Top Operation	2-3
2-3	WJ8711A Rear Panel.....	2-4
2-4	Locating and Setting Configuration DIP Switches A2S1 and A2S2	2-11
2-5	Examples of Set DIP Switches A2S1 and A2S2.....	2-12
4-1	Receiver Status Data Structure.....	4-21
5-1	Recommended Controller Setup	5-2
5-2	Composition of One Byte of Serial Data	5-4
5-3	Format of Typical Command Message Packet.....	5-4
5-4	Format of ACK and NAK Messages	5-5
5-5	Tuned Frequency Command Format Without Acknowledge.....	5-8
5-6	Tuned Frequency Command Format With Acknowledge	5-8
5-7	Tuned Frequency Request Response Format.....	5-9
5-8	Tuned Frequency Range Request Response Format.....	5-10
5-9	Detection Mode/ IF Bandwidth Command Format Without Acknowledge	5-10
5-10	Detection Mode/ IF Bandwidth Command Format With Acknowledge	5-11
5-11	Detection Mode/ IF Bandwidth Request Response Format.....	5-12
5-12	Gain Control Mode Command Format	5-12
5-13	Gain Control Mode Request Format	5-13
5-14	Manual Gain Level Command Format	5-13
5-15	Manual Gain Level Request Format	5-14
5-16	BFO Frequency Command Format.....	5-14
5-17	BFO Frequency Request Response Format.....	5-15
5-18	RF Input Path Command Format.....	5-16
5-19	RF Input Path Request Response Format.....	5-16
5-20	Device Control Mode Command Format.....	5-17
5-21	Device Control Mode Request Response Format.....	5-17
5-22	Jammer Code	5-18
6-1	Digital HF Receiver Functional Block Diagram	6-0
6-2	RF Assembly Block Diagram	6-4
6-3	Digital Assembly Functional Block Diagram.....	6-9
6-4	Front Panel Assembly Functional Block Diagram	6-13
7-1	Power Consumption Performance Test Equipment Connection.....	7-3
7-2	Front Panel Test Equipment Connections.....	7-4
7-3	Reference Frequency Timebase Accuracy Performance Test Equipment Connection.....	7-6
7-4	Fine Tuning Accuracy Performance Test Equipment Connection	7-7
7-5	Receiver Sensitivity Performance Test Equipment Connection.....	7-9
7-6	Audio Distortion Performance Test Equipment Connection.....	7-12
7-7	Squelch/ Mute Performance Test Equipment Connection.....	7-14

TABLE OF CONTENTS (Continued)

LIST OF ILLUSTRATIONS

<u>Figure</u>		<u>Page</u>
7-8	Reconstructed IF Output Performance Test Equipment Connection	7-15
7-9	RF/ IF Signal Path Performance Test Equipment Connection	7-17
7-10	Removing/ Replacing Receiver Top Cover	7-19
7-11	Front Panel Assembly (A1) Remove and Replace Procedures (Part 1).....	7-20
7-12	Front Panel Assembly (A1) Remove and Replace Procedures (Part 2).....	7-21
7-13	Front Panel PC Assembly (A1A1) Remove and Replace Procedures (Part 1)	7-22
7-14	Front Panel PC Assembly (A1A1) Remove and Replace Procedures (Part 2)	7-22
7-15	Digital Control PC Assembly (A2) Remove and Replace Procedures (Part 1).....	7-24
7-16	Digital Control PC Assembly (A2) Remove and Replace Procedures (Part 2).....	7-24
7-17	RF Tuner Assembly (A3) Remove and Replace Procedures (Part 1)	7-25
7-18	RF Tuner Assembly (A3) Remove and Replace Procedures (Part 2)	7-26
7-19	Power Supply (PS1) Remove and Replace Procedures (Part 1)	7-27
7-20	Power Supply (PS1) Remove and Replace Procedures (Part 2)	7-27
7-21	Filter/ Power (FL1J1) Removal and Replacement Procedures (Part 1)	7-28
7-22	Filter/ Power (FL1J1) Removal and Replacement Procedures (Part 2)	7-29
7-23	RAM/ BATTERY (U5) Removal and Replacement Procedures	7-30
8-1	WJ8711A Main Chassis Component Locations.....	8-6

LIST OF APPENDICES

Appendix A	Type WJ871Y/ REF Reference Generator Option (P/ N 181280-001)
Appendix B	Type WJ8711/ PRE Suboctave Preselector Option (P/ N 181281-001)
Appendix C	WJ8711A/ COR Carrier-Operated Relay Option (P/ N 181282-001)
Appendix D	Type WJ8710/ DS01, WJ8711/ DS01, and WJ8712/ DS01 Digital Signal Output Options (P/ N 181272-001)
Appendix E	WJ8711/ 488 and WJ8712/ 488 IEEE488 Interface Options (P/ N 181283-001)
Appendix F	WJ871Y/ 8KRF 8 kHz Roofing Filter Option (P/ N 181284-001)
Appendix G	Future Use
Appendix H	WJ871Y/ 485 RS-485 Interface Option (P/ N 181273-001)
Appendix I	Type WJ871Y/ SEU Speech Enhancement Unit (P/ N 181274-001)
Appendix J	WJ871Y/ IFC125 12.5 kHz IF Output Option (P/ N 181275-001)
Appendix K	Type WJ871Y/ FSK Frequency Shift Keying Option (P/ N 181401-001)

SECTION 1

GENERAL DESCRIPTION

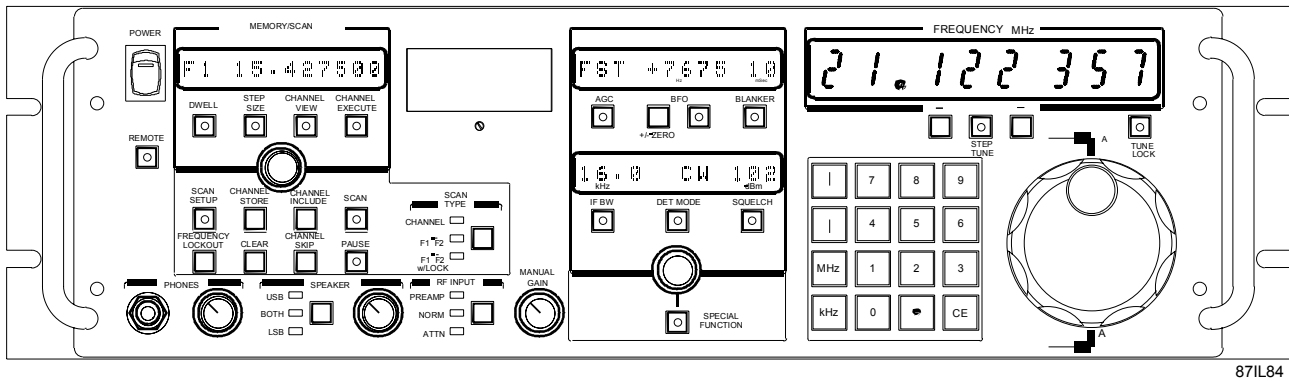

Figure 1-1. WJ-8711A HF Receiver

SECTION 1

GENERAL DESCRIPTION

1.1 ELECTRICAL CHARACTERISTICS

The WJ8711A Digital HF Receiver is a microprocessor-controlled, synthesized receiver capable of continuous 1 Hz tuning resolution over the frequency range of 5 kHz to 30.0 MHz. Available detection modes are AM, FM, CW, ISB, USB, LSB, and Synchronous AM (SAM). Selectable IF bandwidths, including 66 digital IF bandwidth filters and a tunable (non-linear phase) IF notch filter, are standard. Manual or automatic gain control (AGC) modes are selectable. In CW detection mode, beat frequency oscillator (BFO) and passband tuning capabilities are available. The BFO is adjustable over a ± 8000 Hz range. Passband tuning, which is an operator aid that facilitates simultaneous adjustments of tuned frequency and BFO, is adjustable over a ± 2000 Hz range.

The receiver's squelch threshold can be set to any value from 0 to -135 dBm or can be turned off. For use with HF transmitters, audio signals can be muted via the presence of an external control signal input at the receiver's rear panel.

In addition to fixed frequency tuning, the WJ8711A provides a flexible scanning capability. Three scan types are available: channel scan, frequency-to-frequency scan (F1 to F2), and frequency-to-frequency scan with lockouts. In channel scan mode, the receiver steps through a sequence of up to 100 user-programmable memory channels. Receiver parameters stored in each channel include frequency, IF bandwidth, detection mode, BFO, gain control mode, manual gain value, and squelch threshold. Prior to initiating the channel scan, the operator may select a specific range of channels to scan through. Individual channels within the range can be identified for the receiver to skip over during the scan. In both frequency-to-frequency scan modes, the receiver monitors frequencies between programmed start and stop frequencies according to a selected step size between 1 Hz and 25 kHz. For all scan modes, the receiver automatically stops when a signal is acquired that breaks the squelch threshold level. The duration of time the receiver holds on a signal before resuming scan (dwell time) is operator-selectable between 0.5 and 20 seconds. An infinite dwell time can also be selected. A built-in-test (BITE) function is available which can be used to verify equipment performance.

The WJ8711A can be operated locally or remotely. Local operations can be performed using the controls, indicators and displays located on the receiver's front panel (see **Figure 1-1**). The indication of the receiver's tuned frequency is provided on a dedicated 8-digit numeric display. Three separate 12-character alphanumeric displays are provided: one for memory/scan operations and two for general receiver parameter entries. A separate signal strength meter is also provided.

Remotely, the WJ8711A can be controlled either via an RS-232C interface or via a Carrier Sense/ Multiple Access (CSMA) interface bus. Both remote interfaces allow for parameters such as tuned frequency, detection mode, IF bandwidth, gain mode, manual gain, and RF input path to be controlled

remotely. Additionally BITE can be initiated from the RS-232C interface as well as status reporting.

The WJ8711A's internal power supply accepts 90-264 VAC, 47-440 Hz line power as its power source. The unit's internal power supply automatically adjusts to the input power, providing it is within the acceptable limits.

Refer to **Table 1-1** for a complete listing of WJ8711A Digital HF Receiver specifications.

Table 1-1. WJ-8711A Digital HF Receiver Specifications

Frequency Range	5 kHz to 30 MHz (Tunable to 0 Hz, degraded performance below 500 kHz)		
Tuning Resolution	1 Hz		
Internal Reference Stability	Better than 0.7 PPM (0 to 50°C)		
External Reference Frequency	Accepts 1, 2, 5 or 10 MHz (± 1 PPM or better, 200 mV rms into high impedance load). Automatically switches to external reference upon application of signal		
Synthesizer Lock Time	Less than 10 msec typical		
Antenna Input			
Impedance.....	50 ohms, nominal		
VSWR.....	2:1 maximum at receiver's tuned frequency		
Maximum Input Signal	+30 dBm		
Connector.....	BNC female		
Third Order Intercept Point.....	+30 dBm typical, +25 dBm minimum (for signals separated by 50 kHz minimum)		
Second Order Intercept Point.....	+60 dBm typical		
Noise Figure.....	14 dB maximum (11 dB maximum with preamplifier engaged)		
Detection modes	AM, FM, CW, USB, LSB, ISB and SAM (Consult factory for additional demodulation modes)		
Sensitivity (500 kHz - 30 MHz)			
			Without Preamp
Modulation	IF BW	S+N/ N Min	dBm/ μV
AM (50% mod. at 400 Hz)	6.0 kHz	10 dB	-103/ (1.58)
FM (4.8 kHz dev. 400 Hz mod)	8.0 kHz	17 dB (SINAD)	-99/ (2.50)
USB/ LSB/ ISB	3.2 kHz	10 dB	-112/ (0.56)
CW	0.6 kHz	16 dB	-116/ (0.35)
CW Sensitivity, 5 kHz - 500 kHz, without Preamp (0.3 kHz IF Bandwidth)			
50 kHz - 500 kHz.....	-113/ (0.5) dBm/ (μ V) typical for 16 dB S+N/ N		
20 kHz - 50 kHz.....	-105/ (1.27) dBm/ (μ V) typical for 16 dB S+N/ N		
5 kHz - 20 kHz.....	-78/ (28) dBm/ (μ V) typical for 16 dB S+N/ N		

Table 1-1. WJ-8711A Digital HF Receiver Specifications (Continued)

IF Bandwidths:	3 dB <u>Bandwidths</u>	Typical Shape Factor <u>(3/ 60 dB)</u>	3 dB <u>Bandwidths</u>	Typical Shape Factor <u>(3/ 60 dB)</u>
	.056 kHz	1.45:1	1.000 kHz	1.40:1
	.063 kHz	1.40:1	1.100 kHz	1.40:1
	.069 kHz	1.40:1	1.200 kHz	1.35:1
	.075 kHz	1.35:1	1.300 kHz	1.35:1
	.081 kHz	1.35:1	1.400 kHz	1.35:1
	.088 kHz	1.35:1	1.500 kHz	1.35:1
	.094 kHz	1.35:1	1.600 kHz	1.35:1
	.100 kHz	1.30:1	1.800 kHz	1.45:1
	.113 kHz	1.45:1	2.000 kHz	1.40:1
	.125 kHz	1.40:1	2.200 kHz	1.40:1
	.138 kHz	1.40:1	2.400 kHz	1.35:1
	.150 kHz	1.35:1	2.600 kHz	1.35:1
	.163 kHz	1.35:1	2.800 kHz	1.40:1
	.175 kHz	1.35:1	3.000 kHz	1.35:1
	.188 kHz	1.35:1	3.200 kHz	1.30:1
	.200 kHz	1.30:1	3.600 kHz	1.45:1
	.255 kHz	1.45:1	4.000 kHz	1.40:1
	.250 kHz	1.40:1	4.400 kHz	1.40:1
	.275 kHz	1.40:1	4.800 kHz	1.35:1
	.300 kHz	1.35:1	5.200 kHz	1.35:1
	.325 kHz	1.35:1	5.600 kHz	1.35:1
	.350 kHz	1.35:1	6.000 kHz	1.35:1
	.375 kHz	1.35:1	6.400 kHz	1.30:1
	.400 kHz	1.30:1	7.200 kHz	1.45:1
	.450 kHz	1.45:1	8.000 kHz	1.40:1
	.500 kHz	1.40:1	8.800 kHz	1.40:1
	.550 kHz	1.40:1	9.600 kHz	1.35:1
	.600 kHz	1.35:1	10.400 kHz	1.35:1
	.650 kHz	1.35:1	11.200 kHz	1.35:1
	.700 kHz	1.35:1	12.000 kHz	1.35:1
	.750 kHz	1.35:1	12.800 kHz	1.30:1
	.800 kHz	1.30:1	14.400 kHz	1.25:1
	.900 kHz	1.45:1	16.000 kHz	1.20:1

(Consult factory for alternate or additional IF bandwidths)

Table 1-1. WJ-8711A Digital HF Receiver Specifications (Continued)

IF Output	
Center Frequency	455 kHz, nominal
Output Level.....	-20 dBm, nominal
Output Impedance	50 ohms, nominal
Connector Type.....	BNC female
Signal Monitor Output	
Center Frequency	455 kHz, nominal; inverted
Bandwidth.....	30 kHz (-6 dB) minimum
Output Level.....	30 dB above RF Input, nominal
Output Impedance	50 ohms, nominal
Connector Type.....	BNC female
Gain Control Modes.....	Manual, AGC Fast, Medium, and Slow
AGC Range	100 dB minimum
AGC Threshold	Variable. When enabled locally through SPECIAL FUNCTION key and AUXILIARY PARAMETER EDIT knob, operator controls with MANUAL GAIN. Remotely enabled by operator with AGT command and controlled with RFG command.
AGC Attack Time	5 msec typical
AGC Decay Time	Fast: 10-100 msec variable in 10 ms steps Medium: 100-1000 ms variable in 100 ms steps Slow: 1-5 sec variable in 0.5 sec steps
Selectable Front End Gain/ Attenuation	
Preamplifier Gain	10 dB (± 2 dB)
Attenuation	15 dB (± 2 dB)
Beat Frequency Oscillator (BFO)	
Tuning Range	± 8000 Hz
Tuning Resolution	10 Hz
Image Rejection	90 dB minimum
IF Rejection.....	85 dB minimum, greater than 90 dB typical
Internal Spurious Responses.....	<-115 dBm, better than -125 dBm typical
Local Oscillator Phase Noise	-103 dBc @ 1 kHz offset, typical
Reciprocal Mixing	With a desired signal of 25 μ V in the 3.2 kHz IF bandwidth, the desired signal-to-noise ratio is greater than 20 dB, when an undesired signal 70 dB higher in amplitude and 35 kHz removed in frequency is present.
Cross Modulation.....	With a desired signal of 10 μ V an undesired signal 86 dB higher, 30% AM modulated produces less than 10% cross modulation for frequency separation of greater than 50 kHz in the 1 kHz bandwidth.
Blocking	A 1 watt signal produces less than 5% distortion at the Line Audio and IF outputs.

Table 1-1. WJ-8711A Digital HF Receiver Specifications (Continued)

Line Audio Outputs	
Number of Outputs.....	Two center-tapped, balanced outputs. For ISB mode, USB and ISB on separate outputs. For all other modes, audio signal is common to both outputs.
Output Level.....	0 dBm nominal into 600 ohm load
Connector Type.....	Screw Terminals
Speaker Output	
Number of Outputs.....	One output. For ISB mode, USB and ISB can be selected individually or combined. (Internal Speaker optional)
Bandwidth.....	100 Hz to 13 kHz
Output Level.....	Adjustable up to 2 Vrms into 8 ohm load
Total Harmonic Distortion.....	Less than 3%
Connector Type.....	Screw terminals
Headphone Output	
Number of Outputs.....	Two unbalanced outputs. For ISB mode, one output contains USB (left channel), the other contains ISB (right channel). In all other modes, the audio signal is common to both outputs
Output Level.....	Adjustable up to 10 mW into 600 ohm load
Connector Type.....	Standard 1/4" stereo jack
Remote Control.....RS-232C	
RS-232.....	Full duplex, 3-wire serial interface; rear panel 25-pin female D-shell connector
Baud Rates.....	75, 150, 300, 600, 1200, 2400, 4800 and 9600; selectable by internal switches.
Operating Temperature.....	0°C to +50°C
Storage Temperature.....	-40°C to +70°C
Humidity.....	10 Cyclic days (240 Hrs.) Procedure III for Continuous Exposure to 95% RH.
Altitude.....	50,000 ft. non-operating 24,000 ft. operating

Table 1-1. WJ-8711A Digital HF Receiver Specifications (Continued)

Shock (1).....	Bench Handling (Field Service) 8 drops total onto a horizontal hard wooden surface - operating.
MTBF.....	In excess of 14,000 hrs. Estimated in accordance with MILHDBK 217E for Ground Fixed; +40°C environment.
Power Requirements	90 to 264 VAC, 47 to 440 Hz
Power Consumption.....	35 watts typical with options
Dimensions.....	5.25 x 19.0 x 16.0 inches (excluding connectors and controls)
Weight.....	Less than 12 pounds

1.2 MECHANICAL CHARACTERISTICS

The WJ8711A is designed in a full 19-inch rack configuration, occupying 5.25 of vertical rack space and extending 16 inches into the equipment rack. Front panel mounting brackets are provided for installation with the equipment rack. A #10 threaded grounding stud is located on the rear panel for grounding the receiver in the rack. See **paragraph 2.2.1** for rack mounting instructions.

All operation controls and indicators are located on the front panel. All input and output connectors (except for the PHONES jack) are located on the rear panel. Connector types used are BNC, multipin, mini-phones, 1/4-inch stereo headphones jack, and a 13 terminal audio terminal block.

The top and bottom covers and main chassis are constructed of aluminum. The top cover is removable and held in place with 10 screws. Removal of the top cover provides access to all internal circuitry including the following four major assemblies: the Digital Assembly, RF Assembly, Power Supply Assembly, and the Front Panel Assembly.

1.3 EQUIPMENT SUPPLIED

The equipment supplied with the WJ8711A consists of an Intermediate Level Maintenance Manual, a six-foot AC power cord, and four plastic feet. The four plastic feet can be easily installed on the bottom of the unit for table top operation.

1.4 EQUIPMENT REQUIRED BUT NOT SUPPLIED

To obtain full utilization of the receiver, equipment from the following list should be selected:

- HF Antenna, 50 ohm
- Headphones, 600 ohms
- Line audio monitoring equipment
- Signal Monitoring equipment
- Remote Controller, CSMA or RS-232C compatible
- CIV Level Converter (COM Model CT-17) when using the CSMA interface with a RS-232C remote controller.

1.5 RECEIVER OPTIONS

1.5.1 WJ-871Y/ REF REFERENCE GENERATOR OPTION

This factory-installed option improves the WJ8711A internal reference generator stability from better than 0.7 ppm to better than 0.2 ppm over an operating range of 0°C to 50°C. Refer to **Appendix A** for further information on the WJ871Y/ REF option.

1.5.2 WJ-8711/ PRE SUBOCTAVE PRESELECTOR OPTION

This option provides band filtering of the incoming RF spectrum between 0 and 30 MHz for improved second and third order intercept point performance. The WJ8711/ PRE option uses eleven separate filter bands, each covering a segment of the overall range. The appropriate filter is automatically selected as the receiver is tuned. Refer to Appendix B for further information on the WJ8711/ PRE option.

1.5.3 WJ-8711A/ COR CARRIER-OPERATED RELAY OPTION

This option provides a rear panel switching circuit capable of transferring power supplied at the circuit's input connector to external equipment via the output connector only when received signal strengths exceed the defined squelch threshold level. Refer to **Appendix C** for further information on the WJ8711A/ COR option.

1.5.4 WJ-8711/ DSO1 DIGITAL SIGNAL OUTPUT OPTION

This option provides a digital signal output for external digital signal processing. A 15-pin D-subminiature connector is provided on the rear panel of the receiver for digital signal output. Refer to **Appendix D** for further information on the WJ8711/ DSO1 option.

1.5.5 WJ-871Y/ 488 IEEE-488 INTERFACE OPTION

This option provides a communications link between a remote IEEE-488 interface-equipped controller and the receiver's host controller via a rear panel 24-pin GPIB connector. When this option is installed, standard remote operations via the CSMA interface are not available. Refer to **Appendix E** for further information on the WJ871Y/ 488 option.

1.5.6 WJ-871Y/ 8KRF 8 kHz ROOFING FILTER OPTION

This option reduces the receiver's RF bandwidth to 8 kHz, improving the reception of weak signals which are in the presence of large signals at nearby adjacent frequencies. The number of selectable IF bandwidths is reduced to 8 (extending from 58 Hz to 8 kHz) and the receiver's Signal Monitor Output bandwidth is reduced to 8 kHz. Refer to **Appendix F** for further information on the WJ871Y/ 8KRF option.

1.5.7 WJ-8711/ SPK INTERNAL SPEAKER OPTION

The Internal Speaker option provides the receiver the capability to produce audible audio when external speaker sources are not available. An 8-ohm, 4-inch speaker is provided with the option that is mounted to the top cover of the receiver. Audio present at the speaker can be selected with the front panel SPEAKER key and its volume can be controlled by the SPEAKER volume control knob.

1.5.8 WJ-8711/ BFP BLANK FRONT PANEL OPTION

This option replaces the microprocessor front panel with a front panel containing only a power switch, a phone jack, and audio controls. This option is well suited where only remote control of the receiver is desirable.

1.5.9 WJ-871Y/ 485 485 INTERFACE OPTION

This option provides multidrop interface capability to the receiver via a rear panel connector. Refer to **Appendix H** for further information on the WJ871Y/ 485 option.

1.5.10 WJ-871Y/ SEU SPEECH ENHANCEMENT UNIT

The WJ871Y/ SEU Speech Enhancement Unit option uses adaptive filtering techniques to provide enhancement of audio signals that are received from signals in the HF frequency band. The option utilizes these filter techniques to accomplish wideband noise reduction and automatic notch filtering of the audio signals. See **Appendix I**.

1.5.11 WJ-871Y/ IFC125 12.5 kHz IF OUTPUT OPTION

The WJ871Y/ IFC125 12.5 kHz IF Output Option provides a post-filtered IF output on the rear panel of the WJ8711A at A2J1. The output center frequency is 12.5 kHz with a bandwidth equal to the operator-selected IF Bandwidth. Refer to **Appendix J** for further details.

1.5.12 WJ-871Y/ FSK FREQUENCY SHIFT KEYING OPTION

The WJ871Y/ FSK Frequency Shift Keying Option adds the FSK demodulation mode to the standard detection modes available with the WJ8711A. Refer to **Appendix K** for further details.

1.6 WJ-8711A SOFTWARE VERSION RELEASE HISTORY

To ensure efficient receiver operations, the WJ8711A uses three microprocessors, each running its own software code. The front panel microprocessor (A1A1U1) runs the front panel control code, while the digital microprocessor (A2U1) runs the internal control code, and the digital signal processor (A2U37) runs the digital signal processing (DSP) code.

1.6.1 WJ-8711A INTERNAL CONTROL SOFTWARE RELEASE HISTORY

The WJ8711A internal control software is contained in EPROM A2U12. The original internal control software, version 1.00, was released May 23, 1991.

Version 1.10 was never released.

Version 1.20, released December 20, 1991, added the following RS-232C remote commands and queries: AGC, AGC?, BFO, BFO?, BWS, BWS?, CDE?, CTL, CTL?, DET, DET?, FRQ, FRQ?, IDE?, REF?, RFG, RFG?, RFP, RFP?, SGV?, SQL, SQL?, *CIS, *ESE, *ESE?, *ESR?, *RST, *SRE, *SRE?, *STB?, and *TST?. This release also allowed service request handling on the RS-232C interface. This release improved BITE by testing the following receiver areas: the front panel, the DSP circuitry, the RF signal path, and the audio signal path. This release set the default AGC value to FAST AGC, and the IFBW default value to 6 kHz. This release also temporarily mutes the receiver audio when changing the RF input path. When changing detection modes from a non-SSB (AM, FM, CW) detection mode to a SSB detection mode (LSB, USB, ISB), this release

stores the non-SSB IFBW value and selects the 3.2 kHz IFBW. When the detection mode is changed back to a non-SSB detection mode, the previously stored non-SSB IFBW returns. This release disallowed the preamplifier RF input path when tuned below 500 kHz. This release added the selected RF input path to the variables stored in a memory channel. This release added the capability of clearing receiver memory by pressing the clear entry button during power up. This release also displays the actual gain value when in the manual gain mode.

Version 1.21, released February 25, 1992, improved BITE and changed the default BFO value from 0 kHz to +1 kHz.

Version 1.30, released May 27, 1992, added the following RS-232C remote commands and queries: ADV, BIK, BIK?, CHA, CHA?, CHB, CHB?, CHI, CHS, CIM, ENA, EXE, FRA, FRA?, FRB, FRB?, IDN?, INC, INC?, ICK, *IRN?, MUT?, *OPC, *OPC?, OPR, OPR?, PBT, PBT?, RCI?, RIK?, SCF, SCF?, SCS?, SDW, SDW?, SIM?, SPK, STO, SUS, and UIK.

Version 1.40, released June 25, 1992, supported the WJ8711/PRE preselector option, allowed interrupts during BITE, and shortened the lockout stored message to one second. Upon power-up this software version queries the WJ8711A internally with *IDN?. The front panel responds by displaying the unit and current software version (WJ8711,0,vx.xx).

Version 1.41, released July 23, 1992, added the receiver status register to the WJ8711A status structure. This additional register allows the receiver to generate service requests (SRQ) for reporting signal found and end-of-scan. This release also added the following RS-232C remote commands: *RSE, *RSE?, and *RSR?.

Version 3.00.00, released November 12, 1993, added various DSP enhancements to the receiver including the extended IF bandwidths and the tunable notch filter. This release also added the following remote commands: BWC, BWC?, BWN, BWN?, NFM, NFM?, NFR, NFR?, *OPT?, VIA, and VIA?.

Version 3.00.01, released November 19, 1993, improves execution of single-sideband detection modes.

Version 3.01.00 (WJ88711A/488 and WJ8711A/PCSM only), released January 31, 1994, adds IEEE488 interface remote control and PCSM digital signal processing initialization software. This release also improves CSMA implementation, when available.

Version 4.01.00, released August 3, 1994, made the following changes. All IF bandwidths are included on cold start, each detection mode has been associated with an IF bandwidth. The default condition for this association is OFF. An option was added that, when set to ON, causes the manual gain stored in a Memory Channel to be retrieved and stored into the Receiver Manual Gain. The default for this option is ON, *OPT? returns Bit 4 of Byte 2

set. A Speech Enhancement Option was added. The default for this option is OFF. *OPT? returns Bit 1 of Byte 2 set. In order to use the SEU option, the PCSM option must be set ON. The receiver now tunes to zero Hz in ISB, and supports IF bandwidths up to 4 kHz. The receiver now correctly mutes audio when changing detection modes or IF bandwidths. Multidrop RS-485 and RS-422 interfaces are supported. The default value for Tuned Carrier operations is now ON. The default value for Fast AGC decay time is now 40 milliseconds versus 20 milliseconds.

Version 4.00.00, released, August 3, 1994 added variable AGC decay times, medium AGC setting, AGC threshold function and synchronous AM detection mode. This release also added the following remote commands: AGD, AGD?, AGT, AGT?, and STS?.

Version 4.01.02, released December 22, 1994 turns off the Speech Enhancement Unit during BITE or while using the ISB Detection Mode. It also fixed RS-485 so no remote commands were missed.

Version 4.01.03, corrected a lock-up problem that occurred when two *TST? queries were sent in close succession. Also the BFO is now retuned with each change of the detection mode, correcting a tuning problem associated with using passband tuning, changing to another detection mode, and returning to CW. Also now the notch filter works correctly in USB or ISB detection modes with 3.6 or 4.0 kHz IF bandwidths.

Version 4.01.04 involved no functional changes.

Version 4.01.05 corrected deficiencies in the CSMA interface. Released on November 13, 1995, this version is to be used with RS-232 and CSMA only.

1.6.2 WJ-8711A FRONT PANEL CONTROL SOFTWARE RELEASE HISTORY

The WJ8711A front panel control software is contained in EPROM A1A1U3. The original version 1.00 was released May 29, 1991.

Version 1.10 was never released.

Version 1.20, released December 18, 1991, improved the operation of the manual gain knob.

Version 1.21, released July 30, 1992, causes the frequency display LEDs to blink if, at power up, the front panel software is unable to communicate with the internal control software.

1.6.3 WJ-8711A DSP SOFTWARE RELEASE HISTORY

The WJ-8711A DSP software is stored in EPROM A2U56. The original version 1.00, released May 29, 1991.

Version 1.10 was never released.

Version 1.20, released December 17, 1991, increased the EPROM address space from 8000H-FFFFH to 4000H-FFFFH. This release runs properly on the type 797214-1 Digital Board and may not run properly on earlier digital boards.

Version 3.00.01, released November 12, 1993, is required for operation with Internal Control Software Version 3.00.00.

Version 4.00.00, released December 10, 1993, is functionally equivalent to DSP version 3.00.01.

Version 5.00.00, released May 24, 1995, adds the FSK demodulation mode.

SECTION 2

INSTALLATION

THIS PAGE INTENTIONALLY LEFT BLANK

SECTION 2

INSTALLATION

2.1 UNPACKING AND INSPECTION

The WJ8711A and its accessories ships in a cardboard shipping container, designed specifically for its dimensions and weight. After unpacking the equipment, retain the shipping container and packing material until the equipment has been thoroughly inspected and it is ensured that reshipment is not necessary. Perform the following initial inspection:

1. Carefully inspect the outside of the shipping container for discoloring, stains, charring, or other signs of exposure to excessive heat, moisture, or liquid chemicals. Check for any signs of excessive shock or careless handling.
2. Remove all equipment and accessories from the shipping container. If any items are missing, contact the factory or your DRS Signal Solutions, Inc. representative.
3. Remove and retain the white 5x6 inch PRODUCT DISCREPANCY REPORT card. This card should be used if reshipment of the equipment is required. It also contains important warranty adjustment information.
4. Carefully inspect the equipment for dents, scratches, damaged or loose pushbuttons or knobs, or any other signs of physical abuse or careless handling during shipment.

If damage is found, forward an immediate request to the delivering carrier to perform an inspection and prepare a concealed-damage report. Do not destroy any packing material until it has been examined by an agent of the carrier. Concurrently, report the nature and extent of damage to DRS Signal Solutions, Inc., giving equipment serial numbers, so that necessary action can be taken. Under U.S. shipping regulations, claims for damage must be collected by the consignee; do not return the equipment to DRS Signal Solutions, Inc. until a claim for damages has been established.

2.2 INSTALLATION

2.2.1 RACK MOUNTING

The WJ8711A Digital HF Receiver is designed so it can be mounted in a standard 19-inch equipment rack. The unit is 5.25 inches high and extends approximately 16 inches into the equipment rack (**Foldout FO-1**). The use of Jonathan Type 110QD-16-2 chassis slides are recommended for racking mounting the WJ8711A.

The Type 110QD-16-2 chassis slides accommodate the WJ8711A's 17-inch wide chassis into a standard 19-inch wide equipment rack. Supporting loads up to 120 pounds, these slides mount easily into

bracketed equipment racks using machined bar nuts. **Figure 2-1** illustrates installation of the chassis slides to an equipment rack, with special attention given to bracket hole spacing.



CAUTION

Do not use screws longer than 5/16 inch in slide mounting holes of the WJ-8711A. Damage may result to the unit.

Each of the Type 110QD-16-2 chassis slides are comprised of two functional pieces: a chassis section for mounting to the unit and a cabinet section for mounting to the equipment rack. Three 10-32 X 5/16 pan head screws are used to install each chassis section to a side panel of the unit. After both chassis sections have been securely tightened to the unit, cabinet sections are to be installed within the equipment rack. The WJ8711A occupies 5.25 inches of vertical rack space (eight bracket holes). Four of the holes are used to secure the cabinet section of the slide to the equipment rack. Two outer holes are used to secure the unit's front panel to the equipment rack. Slide locks permit quick disconnect of the chassis section of the slides from the cabinet sections for equipment removal. A #10 threaded grounding stud is located on the rear panel for grounding the receiver in the equipment rack. See **paragraph 2.2.4.10**.

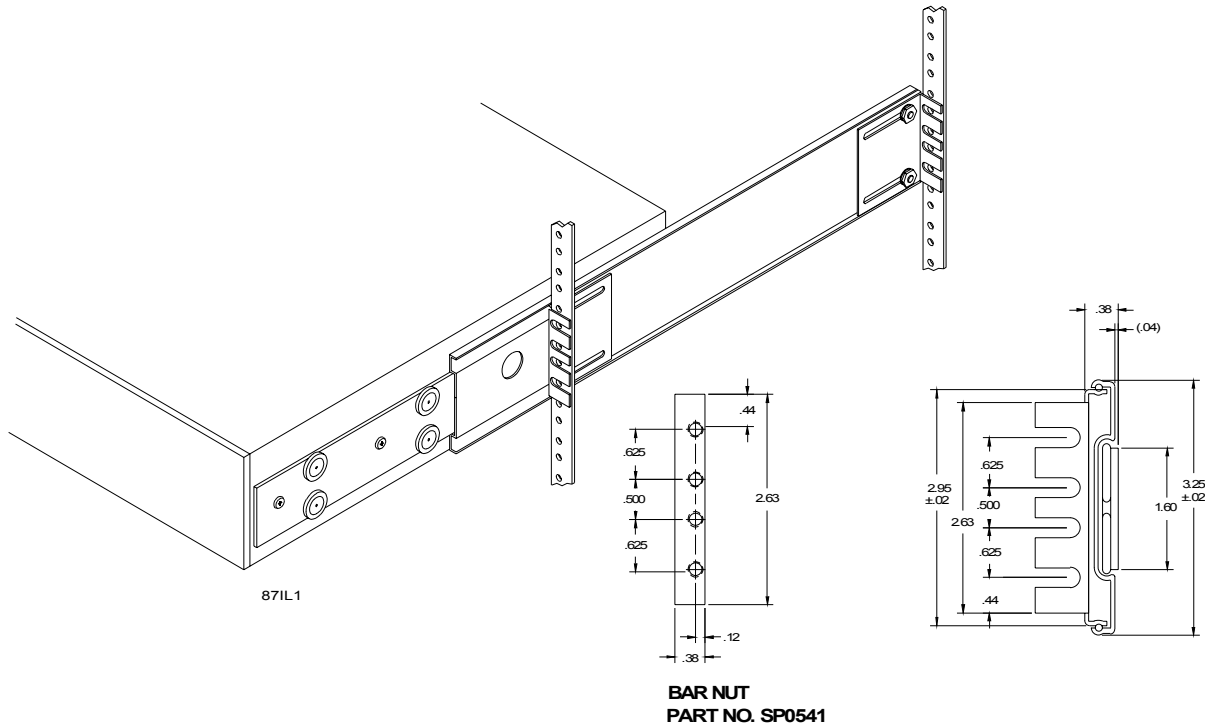

Figure 2-1. Installation of Jonathan Type 110QD-16-2 Slide Mounts

2.2.2 MOUNTING FEET FOR TABLE TOP OPERATION

The WJ8711A can be operated on a bench, table top, or any other clean, dry, secure surface. Provided in the receiver's accessory kit are four plastic mounting feet. These feet should be installed for table top operation.

Four holes are provided on the bottom panel of the receiver for installation of the mounting feet (see **Figure 2-2**). These holes are located approximately 1 inch from the outside corners of the bottom panel. To mount the feet, first make sure their rivet posts are extended. Align each foot with a mounting hole and press in on their rivet posts until they "click" in place.

To remove the feet, first remove the top cover. Place the receiver on its side and locate the extended feet posts inside the receiver's chassis. Push on the rivet posts of the feet to release them from the chassis. Reinstall the top cover.

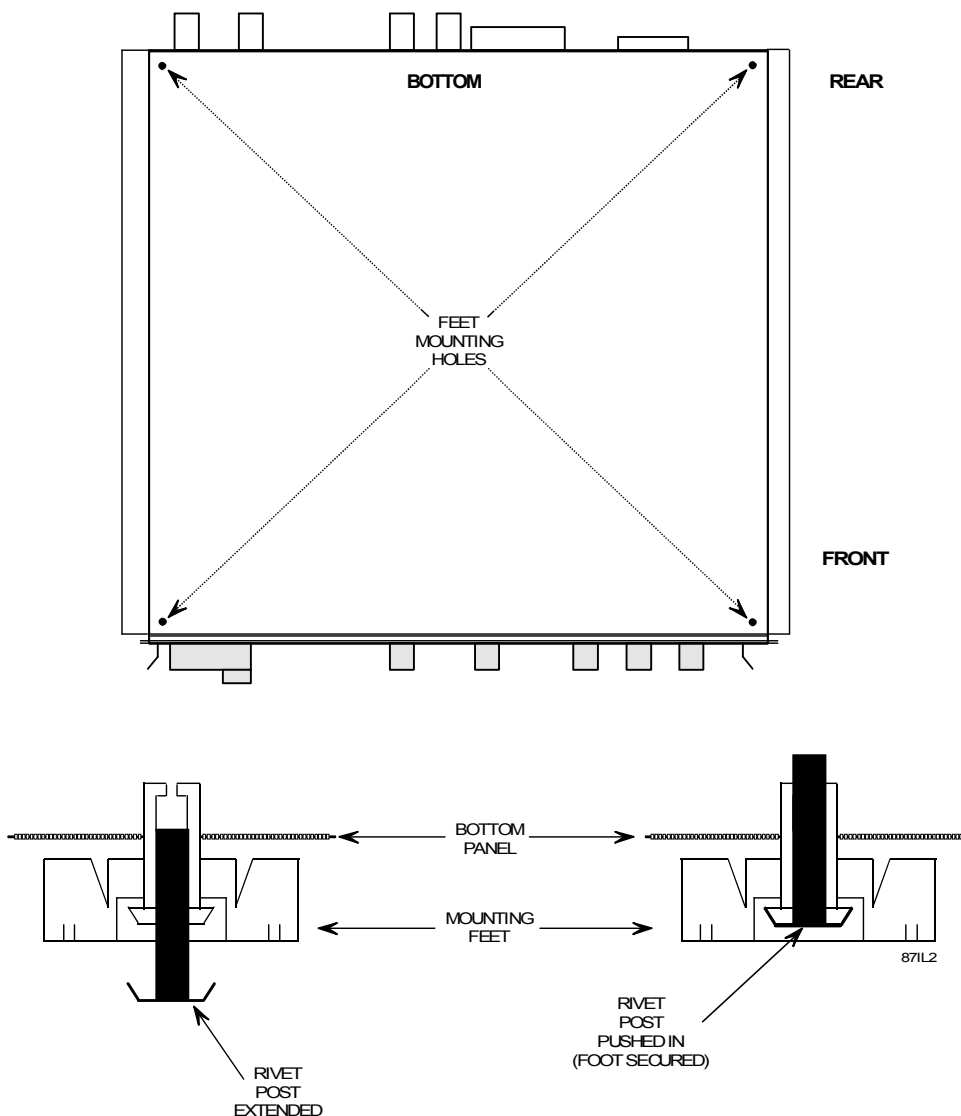

Figure 2-2. Installing the Mounting Feet for Table Top Operation

2.2.3 POWER REQUIREMENTS

The WJ8711A requires an input voltage of 90-264 VAC at 47 to 440 Hz for operation. The receiver's internal power supply circuitry automatically adjusts to the power input applied (providing it is within the specified range). Therefore, no manual switching of power source voltage selection is required. The six-foot line power cord supplied with the receiver connects to the three-prong POWER connector (FL1J1) located on the rear panel. The WJ8711A requires approximately 50 watts for operation.

A 1 amp, slo-blo fuse (FL1F1) is provided and located in a fuse case on the rear panel of the receiver (see **Figure 2-3**). This type fuse is to be used for operation anywhere in the VAC range.

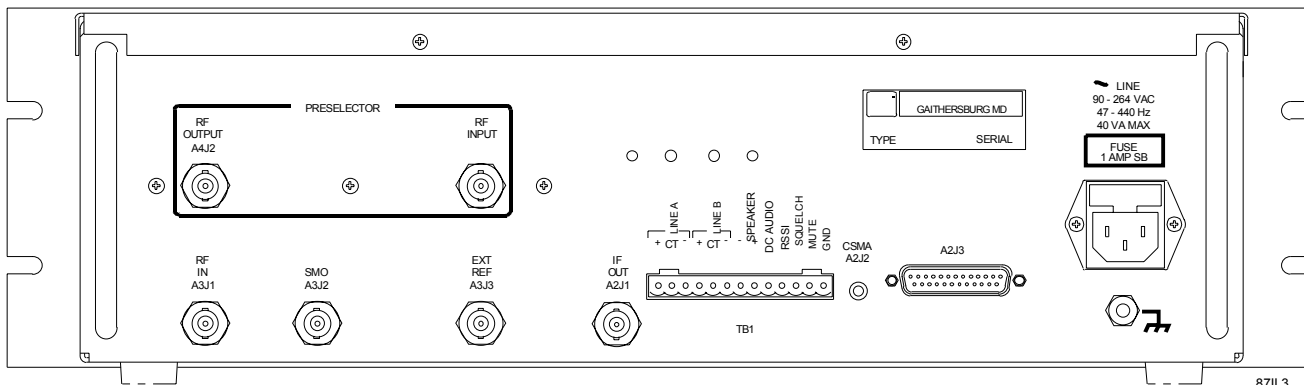

Figure 2-3. WJ8711A Rear Panel

To replace the fuse, first turn off the receiver and disconnect the power cord from the rear panel. Grasp the fuse case and pull straight out of its compartment in FL1. Remove the fuse from the fuse case and replace with a 250 V, 1 amp, slo-blo fuse. Reinstall the fuse case in its compartment and press firmly until it "clicks" in place. Reconnect the power cord.

2.2.4 CONNECTOR SIGNALS

All external connectors of the WJ8711A are located on the rear panel, with the exception of the PHONES jack which is located on the front panel. **Table 2-1** lists these connectors and provides a brief description and the reference designation for each. **Figure 2-3** shows the location of the rear panel connectors. The following paragraphs provide details of the signals resident at the connectors.

Table 2-1. List of Connectors

Connector	Reference Designation	Function
RF IN	A3J1	BNC female. RF input from an antenna (or from A4J2 Preselector Output, when configured with WJ8711/ PRE option).
SMO	A3J2	BNC female. Signal monitor output.
EXT REF	A3J3	BNC female. 1, 2, 5, or 10 MHz reference input.
IF OUT	A2J1	BNC female. Post-filtered IF output.
CSMA	A2J2	Mini-phone. Carrier Sense/ Multiple Access (CSMA) remote interface port (Not used in WJ8711-1).
A2J3	A2J3	D-Type, 25-pin. RS-232C remote serial interface port.
TB1	TB1	Thirteen-terminal audio terminal block. Provides connection for two variable line audio outputs, DC-coupled audio output, speaker output, remote signal strength indication output, squelch output, and mute input.
POWER	FL1J1	Three-prong male receptacle, mates with line power cord. 90-264 VAC 47-440 Hz power input.
PHONES	A1J1	1/4-inch stereo headphones jack. Headphones audio.
PRESELECTOR RF INPUT	A4J1	BNC female. RF input to WJ8711/ PRE option (see Appendix B for detail on WJ8711/ PRE option).
PRESELECTOR RF OUTPUT	A4J2	BNC female. Preselected RF output from WJ8711/ PRE option (see Appendix B for detail on WJ8711/ PRE option).

RF IN, ANTENNA INPUT (A3J1)

This BNC female connector accepts the 5 kHz-30.0 MHz RF input from the antenna or the WJ8711/ PRE Preselector option (if installed). Input impedance is nominally 50 ohms.

SMO, SIGNAL MONITOR OUTPUT (A3J2)

The signal monitor output is a BNC female connector, which provides a sample of the 2nd intermediate frequency, centered at 455 kHz with a

minimum bandwidth of 30 kHz at -6 dB points and an inverted spectrum. The nominal output impedance is 50 ohms with approximately 25 dB of gain from the antenna input. The signal is at the final stage of the analog signal processing prior to digitization and has a tuning resolution of 1 kHz. The SMO output is typically centered and only moves when the user tunes the receiver to a frequency that crosses at 499 to 500 Hz. A signal monitor or other ancillary equipment may use this output. Use IF OUT, which has a 1 Hz resolution, for direct tracking of receivers tuning resolution. See below table for example:

Signal of Interest	Receiver Tuned To	SMO Output A3J2 (Center Frequency)
20 MHz	19.999500 MHz to 20.000499 MHz	455 kHz
20 MHz	19.999499 MHz	Shift Left to 454 kHz
20 MHz	20.000500 MHz	Shift Right to 456 kHz

*EXT REF, EXTERNAL REFERENCE
INPUT (A3J3)*

This female BNC connector allows an external 1 MHz, 2 MHz, 5 MHz, or 10 MHz reference input, having a minimum level of 200 mV rms into a high impedance load, to be used as the time base for the receiver. The WJ8711 automatically switches to external reference operation upon sensing the external reference input signal (providing it is within the specified limits).

*IF OUT, POST-FILTERED IF
OUTPUT (A2J1)*

This BNC female connector provides the post-filtered IF output. The output is centered at 455 kHz with a bandwidth equal to the operator-selected IF bandwidth. The minimum output level is -21 dBm (20 mV) into a 50 ohm load.

*CSMA, CARRIER SENSE/ MULTIPLE
ACCESS PORT (A2J2)*

This mini-phone connector is used as the interface port for Carrier Sense/ Multiple Access (CSMA) remote operations. The connector's center conductor carries the remote data while the sleeve is ground. To ensure electromagnetic compatibility (EMC) with other devices in accordance with IEC EMC standards, use a shielded twisted pair cable when interfacing with the WJ8711A through the CSMA port. See **Section 5** of this manual for details on the CSMA remote interface and operations.

**A2J3, RS-232C SERIAL
INTERFACE PORT**

This D-type, 25-pin connector is used as the interface port for RS-232C remote operations. The RS-232C interface operates as a full duplex interface at a selectable baud rate of 75 to 9600 bps. Pin 2 of this connector is the transmit data line (TXD), pin 3 is the receive data line (RXD) and pin 7 is ground. See **Section 4** of this manual for details on the RS-232C remote interface and operations.

**TB1, AUDIO TERMINAL
BLOCK (TB1)**

This terminal block contains 13 terminals for connection of various inputs and outputs of the receiver such as line audio outputs, speaker outputs, DC-coupled audio output, remote signal strength indicator output, squelch output, and mute input. These input and outputs at the terminals of A2TB1 are further described in the following paragraphs.

**LINE AUDIO OUTPUTS
(TB1 TERMINALS 1 THRU 6)**

Terminals 1 thru 6 of TB1 provide two, center-tapped balanced line audio outputs. One of the line audio outputs (LINE A) is provided on the combination of terminals 1, 2, and 3. Terminal 1 is the positive output (LINE A (+)), terminal 3 is the negative output (LINE A (-)) and terminal 2 is the ungrounded center tap output (LINE A (CT)).

The other line audio output (LINE B) is provided on the combination of terminals 4, 5, and 6. Terminal 4 is the positive output (LINE B (+)), terminal 6 is the negative output (LINE B (-)), and terminal 5 is the ungrounded center tap output (LINE B (CT)).

When the independent sideband (ISB) detection mode is selected, the LINE A output provides upper sideband (USB) audio while the LINE B output provides lower sideband (LSB) audio. In all other detection modes, the LINE A and LINE B outputs provide identical signal content.

The output signal level for input signals above the AGC threshold is 0 dBm nominal (± 3 dB). Output impedance for both line audio outputs is 600 ohms (± 30 ohms). The bandwidth for both line audio outputs is 0.1 to 13.0 kHz, ± 3 dB. Continuous short circuit protection is provided for both outputs.

**SPEAKER OUTPUT (TB1 TERMINALS
7 AND 8)**

Terminals 7 and 8 of TB1 provide an audio output, sufficient to drive an external 8 ohm speaker. Terminal 7 is common (SPEAKER COM), and

terminal eight is positive (SPEAKER (+)). The bandwidth of the output audio is 0.1 to 13.0 kHz at ± 2 dB. Output level is 2 Vrms minimum with less than 3% total harmonic distortion. A speaker output gain control knob is located on the front panel. A clockwise rotation of this knob results in an increase in output signal level.

Lower sideband (LSB) or upper sideband (USB) audio can be selected individually or combined, via the front panel SPEAKER switch while in the ISB detection mode, and made available at the speaker output.

DC-COUPLED AUDIO OUTPUT (TB1 TERMINAL 9)

Terminal 9 of TB1 provides a DC-coupled version of the audio provided at the speaker output (see **paragraph 2.2.4.7.2**).

REMOTE SIGNAL STRENGTH INDICATOR OUTPUT (TB1 TERMINAL 10)

Terminal 10 of TB1 provides an analog output representing the strength of the current detected signal which can be used to drive an external signal strength indicator. The output is a dc voltage which is a linear representation of the strength of the received signal. The output is 0 Vdc for a signal strength of -120 dBm and +5 Vdc for a signal strength of +10 dBm into a high impedance load. This signal is the same used to drive the front panel signal strength meter.

SQUELCH OUTPUT (TB1 TERMINAL 11)

Terminal 11 of TB1 provides a low impedance to ground (capable of sinking 150 mA) when the receiver's signal squelch circuitry is activated (i.e., the detected signal is above the set squelch level). This output is provided for system integration of the WJ8711A. This output appears as a +5 Vdc source through a 100 k Ω impedance when signal squelch is not active.

MUTE INPUT (TB1 TERMINAL 12)

Terminal 12 of TB1 is provided to accept a logic level mute input from an external source. When the input at this terminal is grounded (or driven to a CMOS logic low) all audio outputs of the receiver are disabled.

POWER, 90-264 VAC LINE POWER INPUT (FL1J1)

This three-prong male receptacle mates with the six-foot line power cord that is supplied with the receiver to supply the line voltage for the unit's operation. Acceptable input power is 90-264 VAC at 47 to 440 Hz. The WJ8711A requires approximately 50 watts for operation.

**PHONES, FRONT PANEL
HEADPHONES JACK (A1J1)**

The PHONES connector located on the front panel is a 1/4-inch stereo headphones jack. Each channel of this output provides a minimum of 10 mW at less than 5% total harmonic distortion into a 600 ohm load, when the input signal is above the AGC threshold. Located beside the PHONES jack on the front panel is a volume control knob. A clockwise rotation of this knob results in an increase in headphones output signal level. When the independent sideband (ISB) detection mode is selected, the right channel provides lower sideband (LSB) audio while the left channel provides upper sideband (USB) audio. In all other detection modes, both channels provide identical signal content.

GROUND STUD

A #10 threaded grounding stud is located on the rear panel for grounding the receiver in an equipment frame. See **Figure 2-3** for the location of this grounding stud.

2.2.5 CONFIGURING THE RECEIVER FOR REMOTE OPERATIONS

The WJ8711A contains two DIP switches that can be used to configure the receiver for remote operation. These switches are mounted on the Digital PC Assembly (A2) and are accessed by removing the receiver's top cover (see **Figure 2-4**). The switches are designated A2S1 and A2S2. Each switch contains eight rocker-type switches. The rocker switches are on when they are in the down position and are off when in the up position.

Switches 1 thru 3 of A2S1 are used to set the baud rate for remote operations. Selectable baud rates are 75, 150, 300, 600, 1200, 2400, 4800, and 9600 bps. See **Figure 2-4** for the proper positions of switches 1, 2, and 3 of A2S1 to select the desired baud rate.

Switch 4 of A2S1 is used to enable either the RS-232C or the CSMA/RS-485 interface for remote operations, and to set the baud rate for the selected interface. Setting switch 4 of A2S1 to off (up) enables the RS-232C interface. Conversely, setting switch 4 to on (down) enables the CSMA interface or the RS-485 interface depending on the unit configuration.

Switch 5 of A2S1 is used to select the CSMA frame address. Setting switch 5 of A2S1 to off (up) sets the unit to frame address 24. Conversely, setting switch 5 to on (down) sets the unit to frame address 25.

Switches 6 thru 8 of A2S1 are not used. These switches should always be in the off (up) position.

Switches 1 thru 6 of A2S2 are used to set the receiver's address on the CSMA bus during CSMA remote operations. Valid addresses are from 01 to 63 (address 00 is reserved). See **Figure 2-4** for the proper positions of switches 1 thru 6 of A2S2 to select the desired CSMA bus address.

Switch position 7 of A2S2 determines which message terminator will be transmitted during remote operation. When position 7 is off (up), the message terminator CR/IF (carriage return followed by line feed) is transmitted. When position 7 is on (down), the message terminator CR (carriage return only) is transmitted.

Switch 8 of A2S2 is used to set the tuned frequency command and response formats on the CSMA interface to four bytes or five bytes. It is recommended that the WJ8711A be set for four bytes. Setting this switch to the on (down) position selects the five-byte format and setting it to the off (up) position selects the four-byte format.

When determining the switch settings to achieve a specific binary value, a switch in the off (up) position corresponds to a binary 0 while a switch in the on (down) position corresponds to a binary 1.

Figure 2-5 gives an example of switches A2S1 and A2S2 set to positions to provide particular configurations. In the example, switch A2S1 is set to select CSMA remote operation with a baud rate of 2400 bps. Switch A2S2 is set to provide a CSMA address of 26 and a four-byte tuned frequency format.

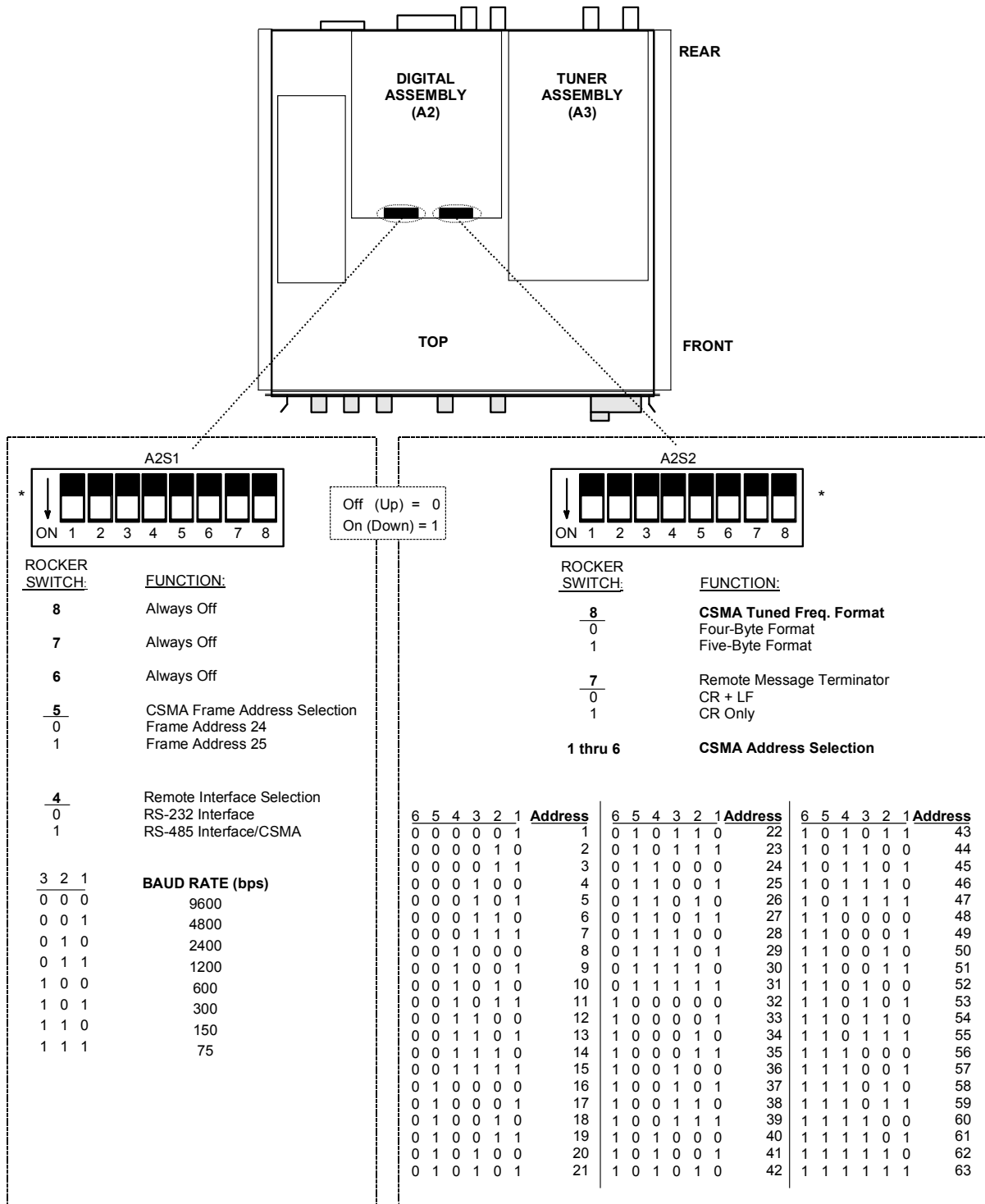

* All positions on both switches are shown in the On (down) position. White indicates slide position.

06-0065

Figure 2-4. Locating and Setting Configuration DIP Switches A2S1 and A2S2

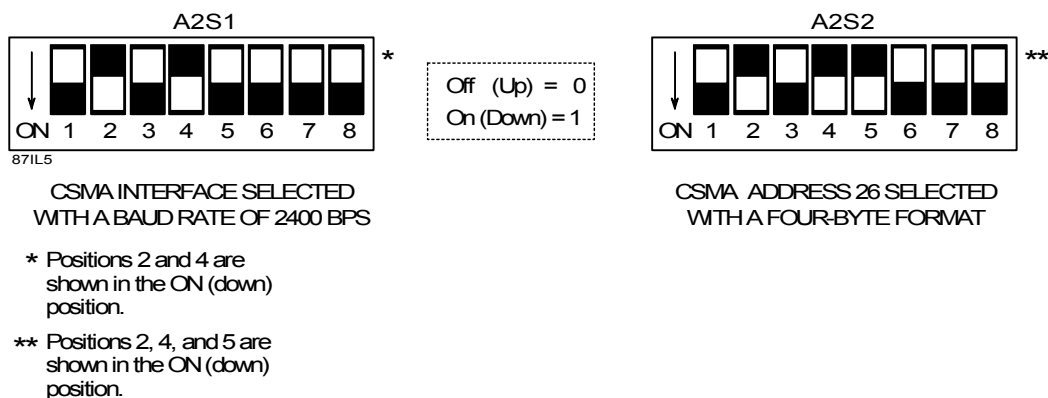

Figure 2-5. Examples of Set DIP Switches A2S1 and A2S2

2.3 EQUIPMENT MALFUNCTIONS

This unit was thoroughly inspected and factory adjusted for optimum performance prior to shipment. If an apparent malfunction is encountered after installation, verify that the correct input signals are present at the proper connectors. Prior to taking any corrective maintenance action or breaking any seals, contact your local sales representative, or the Customer Service Department to prevent the possibility of voiding the terms of the warranty. Contact DRS Signal Solutions, Inc. via mail, telephone, wire, or cable at:

DRS Signal Solutions, Inc.
Customer Service Department
700 Quince Orchard Road
Gaithersburg, Maryland 20878-1794

Toll Free 1-800-954-3577
TELEFAX: 301-948-5666

If reshipment is necessary, follow the instructions in the following paragraph (Preparation for Reshipment or Storage). Do not return the equipment until a Return for Maintenance Authorization (RMA) number has been obtained from the DRS Signal Solutions, Inc. Customer Service Department. See Item 10 in the General Terms and Conditions of Sale document for more information on equipment returns.

2.4 PREPARATION FOR RESHIPMENT OR STORAGE

If the equipment must be prepared for reshipment, the packaging method should follow the pattern established in the original shipment. Use the best packaging materials available to protect the equipment during reshipment or storage. When possible, use the original packing containers and cushioning material. If the original packing materials are not available, use the following procedure:

1. Wrap the equipment in sturdy paper or plastic.
2. Place the wrapped equipment in strong shipping containers and place a layer of shock-absorbing material (3/4-inch minimum thickness) around all sides of the equipment to provide a firm cushion and to prevent movement inside the container.
3. If shipping the equipment for service, fill out all information on the 5x6-inch PRODUCT DISCREPANCY REPORT card that was provided with the original shipment. Also ensure that the Return for Maintenance Authorization (RMA) number is recorded on the card. (See **paragraph 2.7** for details on obtaining this number.) If this card is not available, attach a tag to the equipment containing the following information:
 - a. Return for Maintenance Authorization (RMA) number.
 - b. The Type/ Model number of the equipment.
 - c. Serial number.
 - d. Date received.
 - e. Date placed in service.
 - f. Date of failure.
 - g. Warranty adjustment requested, yes or no.
 - h. A brief description of the discrepant conditions.
 - i. Customer name and return address.
 - j. Original Purchase Order/ Contract number.

4. Thoroughly seal the shipping container and mark **FRAGILE**.

When storing the equipment for extended periods, follow the above packing instructions to prevent damage to the equipment. The safe limits for storage environment are as follows:

Temperature: -40 to +70°C

Humidity: less than 95%

5. Ship to:

DRS Signal Solutions, Inc.
700 Quince Orchard Road
Gaithersburg, MD 20878-1794
U.S.A.

SECTION 3

LOCAL OPERATIONS

THIS PAGE INTENTIONALLY LEFT BLANK

SECTION 3

OPERATIONS

3.1 INTRODUCTION

This section provides information related to the local operation of the WJ8711A Digital HF Receiver using its front panel controls, indicators, and displays. **Paragraph 3.2** provides details on the general use of each control, indicator, and display located on the front panel. The remaining paragraphs provide details on individual functions as listed below:

<u>Function</u>	<u>Paragraph</u>
• Turning on the Receiver	3.3
• Operation in the Manual Mode	3.5
• Storing Current Receiver Parameters in Memory	3.6
• Changing Receiver Parameters to Those Stored in a Memory Channel	3.7
• Operation in the Scan Mode	3.8
• Running the Built-In-Test Function (BITE)	3.9
• Setting Remote Operation Configurations from the Front Panel	3.10

Before attempting to operate the receiver, it is recommended that the operator become familiar with the capabilities of the front panel controls, indicators, and displays by reading the descriptions provided in **paragraph 3.2**.

3.2 DESCRIPTION OF CONTROLS, INDICATORS, AND DISPLAYS

The front panel of the receiver contains all of the controls, indicators, and displays that are used for local operation. **Foldout FO-2** shows their locations on the front panel.

Front panel controls consist of keys, volume control knobs, parameter adjust knobs, and a tuning wheel. Indicators consist of light emitting diodes (LED's) that are located in the center of some keys and LED's that are adjacent to keys. The front panel also provides a -120 to +10 dBm signal level meter. Displays consists of three 12-character, alphanumeric displays and one 8-character numeric display.

As shown in **Foldout FO-2**, three sections of the front panel have shaded backgrounds. These shaded areas are provided as an aid to the operator by grouping sets of keys within particular functional areas of receiver operations. For example, the shaded area on the far left of the front panel indicates that all keys and the display within that area are associated with Memory and Scan operations and is referred to as the Memory/ Scan Section. The shaded area in the center of the front panel contains keys and displays that are associated with the auxiliary parameters of the receiver such as detection mode, IF bandwidth, squelch, etc. This area is referred to as the Auxiliary Parameter Section. The third area highlights the 16-key keypad.

The following paragraphs provide more details on the general use of each control, indicator, and display.

3.2.1 THE TUNED FREQUENCY DISPLAY

The tuned frequency display is an 8-character numeric display, located at the top right-hand corner of the front panel. The label **FREQUENCY MHz** is located just above it. This display shows the receiver's current tuned frequency from 00.000000 to 30.000000 MHz. In some tuned frequency edit modes, a cursor is present in one digit of the display. The cursor takes the form of a digit that is constantly changing in intensity (i.e. the digit appears to be flashing). The cursor is used in decade tuning, meaning that the digit highlighted by the cursor can be adjusted from 0 to 9 using the tuning wheel or up/ down arrow keys. An example of the tuned frequency display is shown below.

FREQUENCY MHz

2 1 . 1 2 2 3 5 7

As seen in the example above, the display contains (from left to right) two digits, a decimal point, and six more digits. The far left digit is the 10-MHz position and the far right digit is the 1-Hz position. A number always appears in each position in the display with the exception of the 10-MHz position. The 10-MHz position is blank when the tuned frequency is 9.999999 MHz or less and the cursor is not currently on that digit. When the tuned frequency is 0.999999 MHz or less, a zero (0) is displayed in the position to the left of the decimal point (1-MHz position).

3.2.2 THE TUNE LOCK KEY AND LED

The function of the TUNE LOCK key is to allow the operator to "lock out" any possibility of changing the displayed tuned frequency, either intentionally or inadvertently by turning the tuning wheel or pressing the up (↑) or down (↓) arrow keys. When the tune lock function is enabled, the LED in the TUNE LOCK key is lit, the cursor disappears from the tuned frequency display, and the up/down arrow keys and tuning wheel are disabled and have no effect when used.

NOTE: The tuned frequency can still be adjusted with the numeric entry keys (*paragraph 3.2.6*) when the tune lock function is enabled.

3.2.3 THE ← (LEFT) AND → (RIGHT) ARROW KEYS

The ← (left) and → (right) arrow keys are located just below the tuned frequency display. The keys have no LED's and are used to move the cursor position in the tuned frequency display. The following are general guidelines to remember when using these keys.

- Pressing either ← or → while the TUNE LOCK LED is lit causes it to extinguish and the tune lock function to be disabled. The cursor in the tuned frequency display appears in the position to which it was previously set.
- Pressing either ← or → while the STEP TUNE LED is lit causes it to extinguish and the Step Tune mode to be exited. The cursor in the tuned frequency display appears in the position to which it was previously set.
- The ← and → keys are not functional while the receiver is actively scanning (i.e. the SCAN key LED is lit and the PAUSE key LED is not lit) or if a numeric entry is in progress and not terminated.
- The ← and → keys move the highlighted digit of the tuned frequency display left and right, respectively, with the following restrictions:
 - 1) the → key has no effect when the highlighted digit is in the 1-Hz position (far right) of the tuned frequency display,
 - 2) the ← key has no effect when the highlighted digit is in the 10-MHz position (far left) of the tuned frequency display, and
 - 3) if no digit is present in the 10-MHz position (the tuned frequency is 9.999999 MHz or less) moving the cursor to this position with the ← key causes a zero (0) to be displayed there.

3.2.4 THE TUNING WHEEL

The tuning wheel is a 2-1/2 inch diameter knob located in the lower right-hand corner of the front panel. The only function of the tuning wheel is to change the receiver's tuned frequency. The following are general guidelines to remember when using the tuning wheel.

- Rotating the tuning wheel clockwise increases and rotating it counterclockwise decreases the receiver's tuned frequency in increments corresponding to the cursor highlighted digit in the tuned frequency display.
- When the Step Tune mode is enabled (STEP TUNE key LED is lit), rotating the tuning wheel clockwise increases and rotating it counterclockwise decrease the receiver's tuned frequency in units equal to the current setting of the Memory/ Scan step size (see **paragraph 3.2.22**).
- The tuning wheel is not functional while the TUNE LOCK key LED is lit, while the receiver is actively scanning or if a numeric entry is in progress and not terminated.
- The receiver's tuned frequency cannot be incremented or decremented beyond the tuning range of the receiver (0.000000 to 30.000000). The display also does not "wrap around" to the other limit (i.e., it will not go from 0.000000 to 30.000000 when decrementing and will not go from 30.000000 to 0.000000 when incrementing).

3.2.5 THE ↑ (UP) AND ↓ (DOWN) ARROW KEYS

The ↑ (up) and ↓ (down) arrow keys are part of the 16-key keypad located below the tuned frequency display. The function of these keys is to change the receiver's tuned frequency. The following are general guidelines to remember when using these keys.

- Each press of the ↑ or ↓ keys increase or decrease, respectively, the receiver's tuned frequency in increments corresponding to the cursor highlighted digit in the tuned frequency display.
- When the Step Tune mode is enabled (STEP TUNE key LED is lit), pressing the ↑ key increases and pressing the ↓ key decreases the receiver's tuned frequency in units equal to the current setting of the Memory/ Scan step size (see **paragraph 3.2.22**).
- The ↑ and ↓ keys are not functional while the TUNE LOCK key LED is lit, while the receiver is actively scanning or if a numeric entry is in progress and not terminated.

- The receiver's tuned frequency cannot be increased or decreased beyond the tuning range of the receiver (0.000000 to 30.000000). The display also does not "wrap around" to the other limit (i.e. it will not go from 0.000000 to 30.000000 when decrementing and will not go from 30.000000 to 0.000000 when incrementing).

3.2.6 THE NUMERIC ENTRY KEYS (0-9 AND DECIMAL POINT)

The numeric entry keys are provided to allow the operator to enter numbers for various receiver parameters instead of using edit knobs or the tuning wheel. A numeric entry can be performed as long as the receiver is not actively scanning. The following are receiver parameters that can be entered with the numeric entry keys:

- Receiver Tuned Frequency (***paragraph 3.5.1***),
- Beat Frequency Oscillator Frequency (***paragraph 3.5.7***),
- Noise Blanker Frequency (***paragraph 3.5.9***),
- Squelch Level (***paragraph 3.5.4***),
- Scan Dwell Time (***paragraph 3.8.1***),
- Scan Lockout Frequency (***paragraph 3.8.2.3***),
- Scan Setups (***paragraph 3.8.2***),
- Step Size (***paragraphs 3.5.1, 3.8.2***), and
- Memory Channel View, Channel Store, Channel Skip, Channel Include (***paragraphs 3.6, 3.7, 3.8***).

Refer to the appropriate paragraphs listed above for the exact use and limitations when using these keys for numeric entries. In all cases however, when a numeric key is pressed the respective number appears in the right-most digit of the frequency display. Pressing another numeric key causes that number to be displayed and causes the previous number to shift one character to the left. Once the entire numeric entry is displayed, a terminator key is pressed to enter the new parameter into the receiver.

The following keys are valid terminator keys for numeric entries:

MHz key
kHz key
SQ UELCH key
BFO key
BLANKER key
IF BW key
SPECIALFUNCTION key
DW ELLkey
STEP SIZE key
CHANNELVIEW key
SCAN SETUP key
FREQUENCY LOCKOUT key
CHANNELSTORE key
CHANNELINCLUDE key
CHANNELSKIP key
CHANNELEXECUTE key

If any other key is pressed while an unterminated numeric entry is in progress, the Memory/ Scan display on the front panel is overwritten and appears as follows:

MEMORY/SCAN

INVALID TERM

indicating that the wrong terminator key was pressed for the numeric information that was displayed. If a numerical entry is out of the parameter range associated with the terminator key, the Memory/ Scan display is overwritten and appears as follows:

MEMORY/SCAN

OUT OF RANGE

indicating that the entry is out of range. All of the above messages will be displayed for three seconds. After that time the displays will return to display the information that was present before the invalid entry was made.

3.2.7 THE KHZ (KILOHERTZ) AND MHZ (MEGAHERTZ) KEYS

The kHz and MHz keys can be used as terminators for numeric entries of the receiver tuned frequency. For example, to enter a tuned frequency of 0.050000 MHz (or 50 kHz), press the 5 key, then the 0 key, and then terminate the entry by pressing the kHz key. The same concept applies to the use of the MHz key.

3.2.8 THE CE (CLEAR ENTRY) KEY

The CE key can be used to clear an unwanted, in progress, numeric entry. This key is functional only when a numeric entry has already been started and a valid terminator key has not yet been pressed. Pressing the CE key causes the entire numeric entry to be erased.

3.2.9 THE STEP TUNE KEY

The STEP TUNE key is used to place the front panel in the Step Tune mode. When in the Step Tune mode, the tuned frequency can be adjusted in steps that correspond to the step size previously set with the STEP SIZE key and indicated in the Memory/ Scan display. (See **paragraph 3.2.22** for details on setting the step size with the STEP SIZE key.)

When the Step Tune mode is entered, the LED in the STEP TUNE key is lit. If the TUNE LOCK key LED is lit when the Step Tune mode is entered, it is turned off. If the tuned frequency display has a highlighted digit (indicating decade tuning) when the Step Tune Mode is entered, the highlighting of that digit is discontinued. Also, when the Step Tune mode is entered, the STEP SIZE key LED in the Memory/ Scan section is lit. The Memory/ Scan display is overwritten and appears as follows:

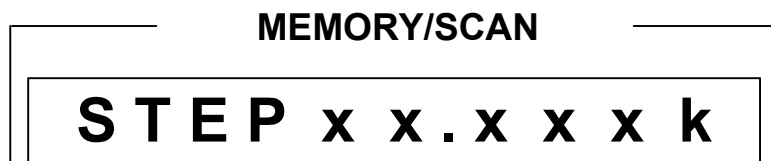

where xx.xxx is the step size parameter value currently in effect. The most significant digit of this display is highlighted, when the Step Tune mode is entered, indicating that it can be adjusted. Therefore, entering the Step Tune mode automatically selects the step size parameter entry mode.

3.2.10 THE AUXILIARY PARAMETER DISPLAYS

The Auxiliary Parameter section of the front panel contains two, 12-character alphanumeric displays. The upper display normally shows, from left to right, the gain control mode, the beat frequency oscillator (BFO) frequency, and the noise blanking interval. The lower display normally shows, from left to right, the IF bandwidth, the detection mode, and the squelch level.

3.2.11 THE IF BW KEY AND LED

The IF BW key is located below the lower display in the Auxiliary Parameter section. This key serves two functions: IF bandwidth select and IF bandwidth enter. IF bandwidth select identifies, from the 66 available IF bandwidth filters, those to be included as available filter choices. The IF bandwidth enter function enters the desired IF bandwidth for the receiver.

The IF bandwidth select mode is enabled by pressing the SPECIAL FUNCTION key until the upper display appears as follows:

IF BW SELECT

The currently selected IF bandwidth filter is displayed in the lower Auxiliary Parameter display along with the work "include" or "skip". When "include" is displayed, that bandwidth is available for selection by the receiver when in the IF bandwidth entry mode. When "skip" is displayed, the bandwidth is not available for selection by the receiver when in the IF bandwidth entry mode. While in the IF bandwidth select mode, each press of the IF BW key toggles the status of the displayed IF bandwidth filter between "include" and "skip". Any or all of the 66 available IF bandwidth filters (see **Table 1-1**) can be included or skipped as desired. The status of each IF bandwidth filter can be viewed in the lower Auxiliary Parameter edit knob. To exit the IF bandwidth select mode, press any other Auxiliary Parameter key, extinguishing the IF BW key and SPECIAL FUNCTION key LEDs.

The IF bandwidth entry mode is enabled by pressing the IF BW key, illuminating the IF BW key LED. The currently selected IF bandwidth is displayed on the lower Auxiliary Parameter display. Each press of the IF BW key steps through the choices of available IF bandwidth filters. Only those IF bandwidth filters that were included for selection using the IF bandwidth select function are available. The IF bandwidth can also be adjusted with the Auxiliary Parameter edit knob when in the IF bandwidth entry mode. The IF bandwidth entry mode can be exited by pressing any other Auxiliary Parameter key, extinguishing the IF BW key LED.

3.2.12 THE DET MODE KEY AND LED

The DET MODE key is located below the lower display in the Auxiliary Parameter section. This key is used to enter the receiver's detection mode. The detection mode entry mode is enabled when the DET MODE key LED is lit. The current selected detection mode is displayed on the lower Auxiliary Parameter display. Each press of the DET MODE key steps through the choices of detection modes: AM, SAM, FM, CW, LSB, USB, and ISB. If the current displayed detection mode is ISB, pressing the key again causes the AM detection mode to be displayed. The detection mode can also be adjusted with the Auxiliary Parameter edit knob when in the detection mode entry mode. The detection mode entry mode can be exited by pressing any other Auxiliary Parameter key, extinguishing the DET MODE key LED.

3.2.13 THE SQUELCH KEY AND LED

The SQUELCH key is located below the lower display in the Auxiliary Parameter section. This key is used to allow the entry of the receiver's squelch level or to turn it off. The squelch parameter entry mode is enabled when the SQUELCH key LED is lit. The squelch parameter can be any value from 0 to -135 dBm or off. The squelch value is displayed in the lower Auxiliary Parameter display. (Note: The negative sign (-) is not displayed.) If the squelch parameter is a numeric value when the squelch parameter entry mode is enabled, the 10-dBm digit is highlighted indicating the entry resolution. Pressing the SQUELCH key again causes the 1-dBm digit to be highlighted. Pressing the key one more time causes "--" to be displayed meaning the squelch is off. Pressing the key while "--" is displayed causes the last entered numeric squelch parameter to be displayed, with the 10-dBm digit highlighted. The squelch value can be adjusted with the numeric entry keys or the Auxiliary Parameter edit knob (refer to **paragraph 3.2.19**). The squelch parameter entry mode can be exited by pressing any other Auxiliary Parameter key, extinguishing the SQUELCH LED.

3.2.14 THE AGC KEY AND LED

The AGC key is located below the upper display in the Auxiliary Parameter section. This key is used to set the gain control mode of the receiver. When the gain control entry mode is active, the LED in the key is lit. The upper Auxiliary Parameter display shows the current gain control setting. Each press of the AGC key steps through the possible choices of FST (AGC fast), MED (AGC medium), SLO (AGC slow), or manual gain. When manual gain is selected, the numeric gain value of 000 to 127 dB can be adjusted with the MANUAL GAIN knob (refer to **paragraph 3.2.39**). If the displayed mode is manual gain, pressing the key again causes FST to be displayed. The gain control mode can also be adjusted with the Auxiliary Parameter edit knob when in the gain control entry mode. The gain control entry mode can be exited by pressing any other Auxiliary Parameter key, extinguishing the AGC LED.

3.2.15 THE BFO KEY AND LED

When the CW detection mode is selected, a beat frequency oscillator (BFO) frequency can be entered. The BFO key is used to allow the entry of the BFO frequency. This key is located below the upper display in the Auxiliary Parameter section. When the BFO entry mode is enabled, the BFO key LED is lit. The current BFO frequency is displayed in the upper Auxiliary Parameter display. The BFO entry can be any frequency from +8000 to -8000 Hz. When the BFO entry mode is entered, the 1-kHz digit of the frequency is highlighted indicating the resolution. Each successive press of the BFO key causes the cursor to shift one digit to the right. If the cursor is present in the 10-Hz position when the key is pressed, the cursor wraps around to the 1-kHz digit. The BFO frequency can be entered with the Auxiliary Parameter edit knob or the numeric entry keys. When numeric entry keys are used, pressing the BFO key terminates the numeric entry. The BFO entry mode can be exited by pressing any other Auxiliary Parameter key, extinguishing the BFO key LED.

3.2.16 THE +/- ZERO KEY

The +/- ZERO key is located below the upper display in the Auxiliary Parameter section. This key provides three functions to alter the BFO setting when the CW detection mode is selected. These functions are listed below.

- When pressed while the displayed BFO value is positive, it changes the BFO value to negative (-).
- When pressed while the displayed BFO value is negative, it changes the BFO value to zero (0000).
- When pressed while the displayed BFO value is zero (0000), it changes the BFO value to the absolute value of the last setting (either positive or negative).

The +/- ZERO key is also used to enable the Tunable Notch Filter when the selected detection mode is other than CW (i.e., AM or FM). This key provides three functions to alter the Tunable Notch Filter. These functions are listed below:

- When pressed while the Tunable Notch Filter is in the OFF mode, it changes the mode to allow the tunable notch to be positioned greater than (>) the tunable carrier frequency.
- When pressed again, the Tunable Notch Filter can be positioned below (<) the tuned carrier frequency.
- When pressed again the Tunable Notch Filter is disabled and OFF is displayed.

3.2.17 THE BLANKER KEY AND LED

The BLANKER key is located below the upper display of the Auxiliary Parameter section. This key is used to enable the entry of the noise blanker parameter for the receiver. The noise blanker parameter can be any value from 1 to 10 or can be set to off. The following are guidelines to remember when using the BLANKER key.

- The noise blanker entry mode is enabled when the BLANKER key LED is lit. The current noise blanker parameter is displayed in the far right area of the upper display in the Auxiliary Parameter section.
- When the noise blanker entry mode is enabled and the noise blanker parameter is a numeric value (not off), the 1's digit is highlighted to indicate resolution.
- Pressing the BLANKER key while a numeric noise blanker value is displayed causes " -" to be displayed, meaning the noise blanker is off.
- Pressing the BLANKER key while " -" is displayed causes the last recent numeric noise blanker value to be displayed.
- The BLANKER key is used as the numeric entry terminator when using the numeric entry keys to enter the noise blanker value.
- The higher the noise blanker value, the more the noise blanking is applied.

The noise blanker entry mode can be exited by pressing any other Auxiliary Parameter key.

3.2.18 THE SPECIAL FUNCTION KEY AND LED

The SPECIAL FUNCTION key is located below the edit knob in the Auxiliary Parameter section. This key provides several functions as listed below:

- Selects the Passband Tuning mode (if in CW detection mode),
- Selects the BITE Initialization mode,
- Selects the Remote Control Selection mode,
- Selects the Remote Baud Rate Entry mode,
- Selects the Remote CSMA Address Entry mode,
- Selects the IF bandwidth select mode,

- Terminates numeric entries in the Passband Tuning mode and the CSMA Address Entry mode.
- Displays the currently selected type of reference frequency (internal or external) and reference frequency (1, 2, 5, or 10 MHz) if external.
- Selects the AGC Threshold feature to enable/disable using the AUXILIARY PARAMETER EDIT knob.
- Sets the user selectable AGC decay rates for the AGC Fast, AGC Medium, and AGC Slow modes.

When any of the above functions are enabled, the SPECIAL FUNCTION key LED is lit. The following paragraphs provide more details on how to select the above functions with the SPECIALFUNCTION key.

**SELECTING THE PASSBAND TUNING
MODE WITH THE SPECIAL
FUNCTION KEY**

The Passband Tuning mode can be enabled by pressing the SPECIAL FUNCTION key while the CW detection mode is selected and one of the following conditions exist:

- The SPECIALFUNCTION key LED is not lit, or
- The SPECIALFUNCTION key LED is lit and the final Special Function menu item is displayed in the upper Auxiliary Parameter display.

When the Passband Tuning mode is enabled, the upper display appears as follows:

P B T U N s n n n n
Hz

where "s" indicates the sign (+ or -) and "nnnn" represents the current Passband Tuning value in Hz. The 100-Hz digit is highlighted to indicate the resolution. The range of the Passband Tuning value is -2000 to +2000 Hz and can be adjusted with the Auxiliary Parameter edit knob. Pressing the SPECIAL FUNCTION key again highlights the 10-Hz digit, allowing the value to be adjusted in 10-Hz steps. The Passband Tuning value can also be entered with the numeric entry keys. When the numeric entry keys are used, pressing the SPECIAL FUNCTION key terminates the numeric entry. **Paragraph 3.5.8** provides further details on the operation of the Passband Tuning mode.

**SELECTING THE BITE INITIALIZATION
MODE WITH THE SPECIAL
FUNCTION KEY**

The BITE (built-in-test) initialization mode can be enabled by pressing the SPECIAL FUNCTION key until the upper Auxiliary Parameter display appears as shown below.

B I T E P E N D I N G
Hz

If the Auxiliary Parameter edit knob is turned in either direction while the above message is displayed, all front panel LEDs are lit indicating that the receiver's built-in-test has been started. Refer to **paragraph 3.9** for more details on the BITE function.

**SELECTING THE REMOTE CONTROL
SELECTION MODE WITH THE
SPECIAL FUNCTION KEY**

The Remote Control Selection mode can be enabled by pressing the SPECIAL FUNCTION key until the upper Auxiliary Parameter display appears as follows:

R E M O T E x x x x x
Hz

Here, "xxxxx" is the current selected remote control mode, either "RS232" or "CSMA". The Auxiliary Parameter edit knob can be used to change the selection. The selection is recognized by the receiver only after power is cycled off and back on. Refer to **paragraph 3.10.1** for more details on selecting the remote control mode.

**SELECTING THE REMOTE BAUD RATE
ENTRY MODE WITH THE SPECIAL
FUNCTION KEY**

The Remote Baud Rate Entry mode can be enabled by pressing the SPECIAL FUNCTION key until the upper Auxiliary Parameter display appears as follows:

B A U D n n n n
Hz

Here, "nnnn" is the current selected baud rate. The Auxiliary Parameter edit knob can be used to select the baud rate. The selection is recognized by the receiver only after power is cycled off and back on.

If CSMA remote control is selected, pressing the SPECIAL FUNCTION key again while the above message is displayed causes the CSMA Address Entry Mode to be selected (*paragraph 3.2.18.5*).

**SELECTING THE CSMA ADDRESS
MODE WITH THE SPECIAL
FUNCTION KEY**

The CSMA Address Entry mode can be enabled by first selecting the CSMA remote control mode (see *paragraph 3.2.18.3*) and then pressing the SPECIAL FUNCTION key until the upper Auxiliary Parameter display appears as follows:

A D D R E S S n n
Hz

Here, "nn" is the current setting of the CSMA address. The address can be entered with the Auxiliary Parameter edit knob (or numeric entry terminated with the SPECIAL FUNCTION key). Range of the address is 1 to 63 (0 is reserved). The selection is recognized by the receiver only after power is cycled off and back on.

**SELECTING THE IF BANDWIDTH
SELECT MODE WITH THE
SPECIAL FUNCTION KEY**

The IF Bandwidth Select mode is selected by pressing the SPECIAL FUNCTION key until the upper Auxiliary Parameter display appears as shown below.

I F B W S E L E C T
Hz

While in the IF Bandwidth Select mode, the IF BW key is used to "include" or "skip" IF bandwidth filters in the IF bandwidth list (see *paragraph 3.5.3.1*).

*DISPLAYING THE CURRENTLY
SELECTED REFERENCE FREQUENCY*

The currently selected reference frequency can be displayed by pressing the SPECIAL FUNCTION key until the upper Auxiliary Parameter display appears as shown below.

REF x x x n n
 Hz

Here, "xxx" is the currently selected type of reference frequency, either INT (internal) or EXT (external). When EXT is displayed, the "nn" is either 1, 2, 5, or 10. This number indicates the frequency, in MHz, of the currently applied external reference. When INT is displayed, the "nn" is blank (the internal reference frequency is always 10 MHz).

*SELECTING THE AGC
THRESHOLD FEATURE*

The AGC Threshold feature is selected by pressing the SPECIALFUNCTION key until the Auxiliary Parameter display appears as below:

AGC THLD ON

or

AGC THLD OFF

Turning the AUXILIARY PARAMETER EDIT knob clockwise enables the feature and turning the knob counterclockwise disables it.

The Variable AGC Threshold feature provides an adjustable AGC threshold which allows the operator to force the receiver to stay in Manual Gain Control mode until a signal exceeding a preset AGC threshold level is detected. Once this strong signal is detected, the receiver forces itself into AGC to help prevent overload and distortion.

The Variable AGC Threshold is most useful in single sideband (SSB) detection mode or in the presence of severely fading signals. With the AGC disabled and the SSB signal inactive, RF noise is amplified to full

scale of the audio channel. When AGC is enabled, all signals below the specified threshold are unaffected by AGC and are not brought up to full scale.

The operation of this feature can be verified by tuning to a SSB signal and slowly reducing the AGC threshold. While the strong SSB signal should sound the same, the noise between the SSB activity drops out since the receiver does not apply AGC.

***SELECTING THE VARIABLE AGC
DECAY TIME FEATURE***

The Variable AGC fast-decay time feature is selected by pressing the SPECIAL FUNCTION key until the Auxiliary Parameter display appears as below:

FST DCY xxx

The fast-decay time is displayed from 10 to 100 milliseconds in 10-millisecond increments. The default setting is 040 milliseconds. Turning the AUXILIARY PARAMETER EDIT knob in a clockwise direction increases the decay time. The counter clockwise direction decreases the decay time.

Pressing the SPECIAL FUNCTION key again accepts the fast decay entry and presents the medium decay field in the Auxiliary Parameter display as shown below. The valid range of medium decay time is from 100 to 1000 milliseconds in 100-millisecond increments. The default setting is 0200 milliseconds. Turning the AUXILIARY PARAMETER EDIT knob in a clockwise direction increases the decay time. The counter clockwise direction decreases the decay time.

MED DCY xxxx

Pressing the SPECIAL FUNCTION key again accepts the medium decay entry and presents the slow decay field in the Auxiliary Parameter display as shown below. The valid range of slow decay time is from 1 to 5 seconds in 0.5-second increments. The default setting is 2.0 seconds. Turning the AUXILIARY PARAMETER EDIT knob in a clockwise direction increases the decay time. The counter clockwise direction decreases the decay time.

SLO DCY X.X

3.2.19 THE AUXILIARY PARAMETER EDIT KNOB

The Auxiliary Parameter Edit knob is located just above the SPECIAL FUNCTION key in the Auxiliary Parameter section of the front panel. This knob can be used to alter various auxiliary parameters of the receiver when certain conditions are met. The following are the functions provided by the Auxiliary Parameter edit knob.

Gain Control: Scrolls up (clockwise) and down (counterclockwise) through gain control modes when the AGC key IED is lit (**paragraph 3.2.14**). The available gain control modes are FST (AGC fast), MED (AGC MED), SLO (AGC slow), and manual (numeric value), in that order.

BFO Frequency: Increases (clockwise) and decreases (counterclockwise) the BFO frequency value in steps corresponding to the highlighted digit of the BFO display when the BFO key IED is lit (**paragraph 3.2.15**). The range of the BFO value is -8000 to +8000 Hz. Attempts to tune beyond these limits are ignored. The BFO value does not go directly from +8000 to -8000 Hz with a clockwise rotation of the edit knob (i.e. no wrap-around).

Noise Blanker: Increases (clockwise) and decreases (counterclockwise) the Noise Blanker value when the BLANKER key IED is lit (**paragraph 3.2.17**). The range of the noise blanker value is 1 to 10 or " - " (off). Attempts to tune beyond these limits are ignored. Turning the edit knob counterclockwise while 01 is displayed causes " - " to be displayed. The noise blanker value does not go directly from 10 to " - " with a clockwise rotation of the edit knob (i.e. no wrap-around).

IF Bandwidth:	Scrolls up (clockwise) or scrolls down (counterclockwise) through the available IF bandwidths when the IF BW key IED is lit (paragraph 3.2.11). The IF bandwidth selection does not go directly from the maximum to minimum bandwidth when the edit knob is turned clockwise, nor does it go directly from the minimum to maximum bandwidth when turned counterclockwise (i.e. no wrap-around).
Detection Mode:	Scrolls up (clockwise) or scrolls down (counterclockwise) through the available detection modes when the DET MODE key IED is lit (paragraph 3.2.12). The selectable detection modes are AM, SAM, FM, CW, LSB, USB, and ISB, in that order. The IF detection mode selection does not go directly from ISB to AM when the edit knob is turned clockwise, nor does it go directly from AM to ISB when turned counterclockwise (i.e. no wrap-around).
Squelch Level:	Increases (clockwise) and decreases (counterclockwise) the squelch value in steps corresponding to the highlighted digit of the squelch parameter display when the SQUELCH key IED is lit (paragraph 3.2.13). The range of the squelch parameter is 0 to -135 dBm or "---" (off). Turning the edit knob counterclockwise while 135 is displayed causes "---" to be displayed. Turning the edit knob counterclockwise while "---" is displayed has no effect. Turning the edit knob clockwise while "---" is displayed causes 135 to be displayed with the 10-dBm digit ("3") highlighted. Turning the knob clockwise while the maximum squelch parameter is displayed (000) does not directly step the parameter to the minimum value (-135 dBm) or "---".
Passband Tuning:	Increases (clockwise) or decreases (counterclockwise) the passband tuning parameter in 100-Hz steps when the SPECIAL FUNCTION key IED is lit, the Passband Tuning mode is enabled, and the 100-Hz digit is highlighted in the passband tuning display (paragraph 3.2.18.1). Increases (clockwise) or decreases (counterclockwise) the passband tuning parameter in 10-Hz steps when the 10-Hz digit is highlighted in the passband tuning display.

Tunable Notch Filter: Increases (clockwise) or decreases (counterclockwise) the position of the tunable notch filter. The range is ± 9999 Hz in 1 Hz steps. This setting represents the position of the notch filter with respect to the tuned carrier frequency.

AGC Threshold Feature: Toggles the AGC Threshold feature on (clockwise) or off (counterclockwise) when the SPECIAL FUNCTION key LED is lit. The threshold gain level is controlled by the MANUALGAIN knob.

AGC Decay Setting: Sets the AGC decay time for the three AGC modes when the SPECIAL FUNCTION key LED is lit and one of the three AGC modes is present in the AUXILIARY display.

3.2.20 THE MEMORY/ SCAN SECTION ALPHANUMERIC DISPLAY

The Memory/ Scan section of the front panel contains a 12-character alphanumeric display. This display provides information pertinent to the current setting of the Memory/ Scan section controls.

3.2.21 THE DWELL KEY AND LED

The DWELL key is located below the alphanumeric display in the Memory/ Scan section of the front panel. This key is used to enable the entry of dwell times for Scan operations. Pressing this key causes its LED to light and the dwell entry mode to be entered and displayed on the Memory/ Scan display.

When the dwell entry mode is enabled, the current dwell value is shown on the display. The displayed dwell time can be any value from 0.5 to 20.0 seconds or can be infinite. If the current dwell value is numeric, the far left numeric digit is highlighted indicating resolution. Pressing the DWELL key again causes the cursor to shift one digit to the right. Pressing the DWELL key while the far right digit is highlighted causes "DWL INFINITE" to be displayed. If the key is pressed while "DWL INFINITE" is displayed, the last numeric dwell entry is redisplayed with the far left digit highlighted. The Memory/ Scan edit knob can be used to adjust the highlighted value. The DWELL key is also used as a terminator key when using numeric entry keys to enter the dwell time. Refer to **paragraph 3.8.1** for details on dwell time operation.

3.2.22 THE STEP SIZE KEY AND LED

The STEP SIZE key is located below the alphanumeric display in the Memory/ Scan section of the front panel. This key is used to enter the step size parameter entry mode. The step size parameter serves two functions: it defines the tuned frequency increment value when the STEP TUNE key

IED is lit (*paragraph 3.2.9*) and it defines the step size used in a frequency-to-frequency scan setup. The step size can also be adjusted by entering the scan setup menu with the SCAN SETUP key (*paragraph 3.2.26*).

When the STEP SIZE key is pressed, its IED becomes lit and the alphanumeric display shows the current step size with the most significant (far left) digit highlighted indicating resolution. Below is an example of the alphanumeric display in the step size entry mode:

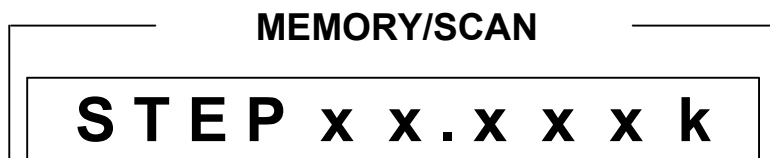

where xx.xxx is the current step size value in kHz. Pressing the key again causes the highlighted position to shift one digit to the right. Pressing the key while the least significant (far right) digit is highlighted causes the most significant digit to be highlighted. The STEP SIZE key can also be used as a terminator when using the numeric keys for entering the step size. This key is not functional while the receiver is actively scanning (i.e., the SCAN key IED is lit and the PAUSE key IED is not lit).

3.2.23 THE CHANNEL VIEW KEY AND LED

The CHANNELVIEW key is located below the alphanumeric display in the Memory/ Scan section of the front panel. This key is used to view the frequencies stored in the receiver's memory channels. The first press of the key causes the last viewed channel to be displayed in the Memory/ Scan section alphanumeric display. The memory channel number is displayed prefixed with an "s" for skipped channels or an "i" for included channels. (Refer to *paragraph 3.2.31* for details on using the CHANNELSKIP key and to *paragraph 3.2.30* for details on using the CHANNELINCLUDE key.) The frequency stored in the current channel is also displayed in MHz, with 10-Hz resolution. The following is an example of the standard channel view display.

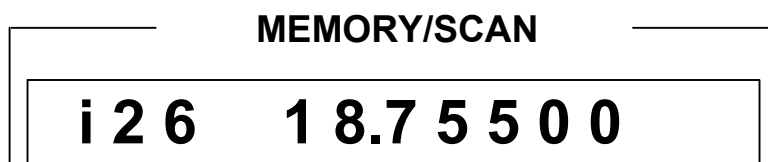

If the receiver is actively performing a Channel Scan, pressing the CHANNEL VIEW key causes "SCANNING XX" to be displayed where "XX" is the current channel to which the receiver is tuned ("XX" continuously changes as the receiver moves from channel to channel). If the receiver is dwelling or if the PAUSE key is pressed, the display reverts back to the

standard channel view format showing the channel number and the corresponding stored frequency.

When the standard channel view format is displayed and an unterminated numeric entry is not in progress, pressing the CHANNEL VIEW key causes the next higher channel number and its frequency to be displayed. Valid channel numbers are from 00 to 99. Pressing the CHANNEL VIEW key while channel 99 is displayed causes channel 00 to be displayed. This key can also be used as a terminator after entering a channel number with the numeric entry keys.

3.2.24 THE CHANNEL EXECUTE KEY AND LED

The CHANNEL EXECUTE key is located below the alphanumeric display in the Memory/ Scan section of the front panel. This key can be used to set the receiver to the parameter values stored in the displayed memory channel. If a memory channel is not visible in the alphanumeric display when the CHANNEL EXECUTE key is pressed, the Channel View mode is automatically entered, lighting the CHANNEL VIEW key LED. The receiver parameters stored in the displayed memory channel (including frequency, IF bandwidth, detection and gain modes, manual gain value, BFO setting, and squelch level) are immediately executed by the receiver. Because Channel View mode is active when the CHANNEL EXECUTE key is lit, the Memory/ Scan edit knob or the CHANNEL VIEW key can be used to sequence through the stored memory channels, with the receiver executing each channel as it is displayed. Once entered, the Channel Execute mode can be exited by either pressing CHANNEL EXECUTE key again, by entering the Scan mode, or by altering a receiver parameter such that an exact match no longer exists between the displayed memory channel parameters and the receiver settings.

3.2.25 THE SCAN TYPE KEY AND LEDS

The SCAN TYPE key is located in the Memory/ Scan section of the front panel below the signal strength meter. Directly to the left of the key are three LED's. The LED that is lit indicates the selected scan type: CHANNEL for channel scan, F1 → F2 for start frequency to stop frequency scan, and F1 → F2 w/ LOCK for start frequency to stop frequency scan with lockout frequencies bypassed. Each press of the key changes the scan type. The scan type currently selected, indicated by the lit LED, can be set up with the SCAN SETUP key (**paragraph 3.2.26**).

3.2.26 THE SCAN SETUP KEY AND LED

The SCAN SETUP key is located below the alphanumeric display in the Memory/ Scan section of the front panel. This key is used to set up a scan operation for the receiver. When the key is pressed, its LED lights indicating the scan setup mode is enabled, and the Memory/ Scan section's alphanumeric display shows the first line of the scan setup menu. The scan

setup menu displayed is dependent on the current scan type selected with the SCAN TYPE key, and indicated by the lit scan type IED. Each press of the SCAN SETUP key causes the next line of the scan type setup menu to be displayed. Pressing the SCAN SETUP key in succession while the CHANNEL scan type IED is lit causes the alphanumeric display to scroll through the following menu items:

START CHA XX (where XX is the current start channel)
 STOP CHA XX (where XX is the current stop channel)
 DWELLXX.X s (where XX.X is the current dwell time in seconds)
 or
 DWLINFINITE (when the dwell time is set to infinite)

Pressing the SCAN SETUP key in succession while the F1 → F2 scan type IED is lit causes the alphanumeric display to scroll through the following menu items:

F1 XX.XXXXXX (where XX.XXXXXX is the current start frequency in MHz)
 F2 XX.XXXXXX (where XX.XXXXXX is the current stop frequency in MHz)
 STEP XX.XXXk (where XX.XXX is the current step size frequency in kHz)
 DWELLXX.X s (where XX.X is the current dwell time in seconds)
 or
 DWLINFINITE (when the dwell time is set to infinite)

Pressing the SCAN SETUP key in succession while the F1 → F2 w/ LOCK scan type IED is lit causes the alphanumeric display to scroll through the following menu items:

F1 XX.XXXXXX (where XX.XXXXXX is the current start frequency in MHz)
 F2 XX.XXXXXX (where XX.XXXXXX is the current stop frequency in MHz)
 STEP XX.XXXk (where XX.XXX is the current step size frequency in kHz)
 DWELLXX.X s (where XX.X is the current dwell time)
 or
 DWLINFINITE (when the dwell time is set to infinite)

Lk XX.XXXXXX (where XX.XXXXXX is the lowest lockout frequency in MHz)

(each key press scrolls through the entered lockout frequencies in frequency-numeric order between F1 and F2)

Lk XX.XXXXXX (where XX.XXXXXX is the highest lockout frequency in MHz)

After completely scrolling through the scan setup menu, pressing the SCAN SETUP key again exits the scan setup mode. This key can also be used as numeric entry terminator when using the numeric entry keys to enter scan setup parameters. Using the key as a terminator causes the new value to appear in the Memory/ Scan alphanumeric display for a period of three seconds, after which time the display automatically increments to the next menu item.

3.2.27 THE FREQUENCY LOCKOUT KEY

The FREQUENCY LOCKOUT key is located directly below the SCAN SETUP key in the Memory/ Scan section of the front panel. The key is used to store the current receiver tuned frequency and selected IF bandwidth in one of the lockout memory locations of the receiver. Up to 100 lockout frequencies can be entered. When the FREQUENCY LOCKOUT key is pressed, the Memory/ Scan alphanumeric display appears as shown below for one second.

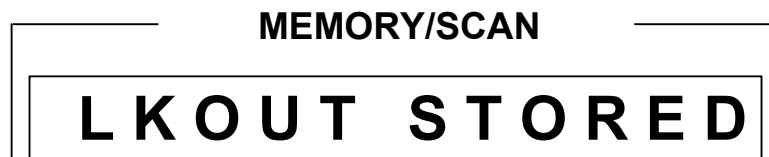

After one second the display returns to its previous state. If an attempt is made to enter a new lockout frequency when 100 lockout frequencies are already entered, the following message is temporarily displayed indicating the lockout memory is full. :



Lockout frequencies cannot be entered with the FREQUENCY LOCKOUT key while the receiver is actively scanning. An attempt to enter a lockout frequency while the receiver is actively scanning causes the following message to be displayed for three seconds:



which indicates the scan must be paused before the lockout frequency can be entered.

3.2.28 THE CHANNEL STORE KEY

The CHANNEL STORE key is located below the edit knob in the Memory/ Scan section of the front panel. This key is used to enter receiver parameters into one of the memory channels. If not currently in the channel view mode, the first press of the key causes the channel view mode to be entered (see **paragraph 3.2.23**) and the channel that was last stored or viewed to be shown on the Memory/ Scan section alphanumeric display. Once the channel view mode is enabled, pressing the CHANNEL STORE key causes the receiver parameters to be stored in the displayed memory channel, overwriting the previous data for that memory channel. The stored parameters are tuned frequency, gain mode, manual gain level, IF bandwidth, detection mode, BFO setting, and squelch level.

3.2.29 THE CLEAR KEY

NOTE: The CLEAR key can be used to clear all lockout and channel memory. Read the following paragraphs carefully to avoid accidental deletion of stored scan parameters.

The CLEAR key is located directly below the CHANNEL STORE key in the Memory/ Scan section of the front panel. This key serves several functions as listed below.

- Pressing this key while a lockout frequency is displayed in the scan setup mode (**paragraphs 3.2.26 and 3.2.27**), causes the displayed frequency to be cleared from the lockout memory.
- Pressing this key while a lockout frequency is not displayed causes the current Memory/ Scan section entry mode to be exited and the alphanumeric display to be cleared.

- Pressing this key twice while a lockout frequency is not displayed causes the following message to be displayed on the alphanumeric display.

MEMORY/SCAN

N E X T = C L R M E M

- Pressing the CIEAR key while the above message is displayed clears the contents of all lockout and memory channels and causes "MEM CIEARED" to be displayed.
- Pressing the CIEAR key three times in succession (while a lockout frequency is not displayed) clears the contents of all lockout and memory channels.

3.2.30 THE CHANNEL INCLUDE KEY

The CHANNEL INCIUDE key is located below the edit knob in the Memory/ Scan section of the front panel. Pressing this key forces the receiver into the channel view mode if not already entered. Pressing this key while in the channel view mode places the displayed channel in the "include" status. This means that when the receiver is scanning in the channel scan mode, the channel will be visited as long as it is within the start and stop channels. A channel set to the "include" status is indicated by an "i" located to the left of the channel number in the alphanumeric display. After setting a channel to the "include" status with the CHANNEL INCIUDE key, the new prefix appears in the display for three seconds. The display then automatically increments to the next higher channel number.

To place a channel in include status, enter the channel number with the numeric entry keys, and terminate the entry with the CHANNEL INCIUDE key. Groups of successive channels can be set to the "include" status by entering the lowest channel number of the group, a decimal point, and the highest channel number of the group, and terminating with the CHANNEL INCIUDE key. This action causes the display to show the highest channel number of the group prefixed with an "i" for three seconds, then automatically increments to the next higher channel number.

3.2.31 THE CHANNEL SKIP KEY

The CHANNELSKIP key is located directly below the CHANNEL INCIUDE key in the Memory/ Scan section of the front panel. Pressing this key forces the receiver into the channel view mode if not already entered. Pressing this key while in the channel view mode places the displayed channel in the "skip" status. This means that when the receiver is scanning in the channel scan mode, the channel will not be visited regardless if it is within the start

and stop channels. A channel set to the "skip" status is indicated by an "s" to the left of the channel number in the alphanumeric display. After setting a channel to "skip" status with the CHANNEL SKIP key, the new prefix appears in the display for three seconds. The display then automatically increments to the next higher channel number.

The channel number for skip status can be entered with the numeric entry keys, terminated with the CHANNEL SKIP key. Groups of successive channels can be set to the "skip" status by entering the lowest channel number of the group, a decimal point, and the highest channel number of the group, and terminating with the CHANNEL SKIP key. This action causes the display to show the highest channel number of the group prefixed with an "s" for three seconds, then automatically increments to the next higher channel number.

3.2.32 THE SCAN KEY AND LED

The SCAN key is located to the right of the CHANNEL INCLUDE key in the Memory/ Scan section of the front panel. This key is used to place the receiver in and out of the scan mode. When this key is pressed, its IED becomes lit and the receiver automatically begins scanning. The type of scan operation that is started is indicated by the lighting of the SCAN TYPE IEDs (refer to **paragraph 3.2.25**). The parameters of the scan operation are dependent on the scan setup entered with the SCAN SETUP key (refer to **paragraph 3.2.26**). Pressing the SCAN key while its IED is lit causes the scan operation to be halted, the scan mode to be exited, and the IED to extinguish.

3.2.33 THE PAUSE KEY AND LED

The PAUSE key is located directly below the SCAN key in the Memory/ Scan section of the front panel. This key is used to pause (stop) an active scan operation and is only functional while the SCAN key IED is lit. When the scan operation is paused, the PAUSE key IED is lit. The main advantage of this function is to allow the operator to immediately monitor a signal that is acquired during the scan operation, without waiting for the scan to cycle through to its stop parameter. The scan can be continued by pressing the PAUSE key again. The scan resumes at the next point in the scan and the PAUSE key IED extinguishes.

<p>NOTE: Pressing the PAUSE key while its IED is lit resumes the scan operation regardless of whether or not the dwell timer has stopped. As a result, the operator can restart a scan from an unwanted acquired signal, by pressing the PAUSE key twice (once to pause the scan and again to resume the scan).</p>
--

3.2.34 THE MEMORY/ SCAN PARAMETERS EDIT KNOB

The Memory/ Scan parameters edit knob is located below the STEP SIZE and CHANNEL VIEW keys in the Memory/ Scan section of the front panel. This knob can be used to alter various Memory/ Scan parameters of the receiver when certain restrictions are met. The following are the functions provided by the Memory/ Scan parameter edit knob.

Dwell Timer: Increments (clockwise) or decrements (counterclockwise) the dwell timer parameter in steps corresponding to the highlighted digit of the dwell timer display when the DWELL key LED is lit (**paragraph 3.2.21**). The range of the dwell timer value is 0.5 to 20.0 seconds or can be set to INFINITE. The dwell time parameter does not go directly from DWLINFINITE to 0.5 seconds with a clockwise rotation of the edit knob (i.e., no wrap-around).

Step Size: Increments (clockwise) or decrements (counterclockwise) the step size parameter in steps corresponding to the highlighted digit of the step size display when the STEP SIZE key LED is lit (**paragraph 3.2.22**). The range of the step size parameter is 0.001 to 25.0 kHz. The step size parameter does not go directly from 25.0 to 0.001 with a clockwise rotation of the edit knob (i.e., no wrap-around).

Channel Number: Increments (clockwise) or decrements (counterclockwise) the channel number in the channel view mode when the CHANNEL VIEW key LED is lit (**paragraph 3.2.23**). The range of channel numbers is 00 to 99. Rotating the edit knob clockwise while channel number 99 is displayed causes channel number 00 to be displayed and rotating counterclockwise while 00 is displayed causes 99 to be displayed (i.e., wrap-around).

Scan Setup: Rotating the edit knob clockwise or counterclockwise scrolls up or down through the scan setup menu, respectively, when the SCAN SETUP key LED is lit (**paragraph 3.2.26**).

3.2.35 THE PHONES OUTPUT VOLUME CONTROL KNOB

The PHONES output volume control knob is located to the right of the PHONES jack on the bottom left-hand corner of the front panel. This knob is used to increase or decrease the volume level of the audio output on both channels of the PHONES jack. A clockwise rotation increases the volume of a nominal audio signal up to approximately 10 milliwatts and a counterclockwise rotation decreases the volume to approximately 0 milliwatt. This control is also operational while the receiver is in remote mode.

3.2.36 THE SPEAKER KEY AND LEDS

The SPEAKER key is located to the right of the PHONES output volume control knob. This key is used to select the audio to be applied to the speaker outputs on pins 7 and 8 of audio terminal block TB1, located on the rear panel, when the ISB (independent sideband) detection mode is selected. Each press of the key toggles through the available selections of USB (upper sideband), BOTH, and LSB (lower sideband), lighting the appropriate LED to the left of the key.

When USB is selected, only upper sideband audio is provided at the speaker output. When BOTH is selected, upper sideband and lower sideband audio are provided at the speaker output. When LSB is selected, only lower sideband audio is provided at the speaker output. This key has no effect on the speaker output when any detection mode other than ISB is selected.

The SPEAKER key also controls the audio available at the optional internal speaker when installed.

3.2.37 THE SPEAKER OUTPUT VOLUME CONTROL KNOB

The SPEAKER output volume control knob is located to the right of the SPEAKER key on the front panel. This knob is used to increase or decrease the volume level of the audio signal present at the speaker output on pins 7 and 8 of terminal strip TB1 located on the rear panel. A clockwise rotation increases the volume of a nominal audio signal, up to approximately 1 watt. A counterclockwise rotation decreases the volume, down to approximately 0 milliwatts. This control is operational while the receiver is in remote mode. It also is used to control the volume at the optional internal speaker when installed.

3.2.38 THE RF INPUT KEY

The RF INPUT key is located to the right of the SPEAKER volume control knob on the front panel. This key is used to select the path of the input RF signal, prior to being applied to any IF conversions. Each press of the key toggles through the available selections of PREAMP (preamplifier), ATTN (attenuator), or NORM (normal: neither amplified or attenuated).

Preamplifier is selected when the PREAMP IED is lit. In this selection, the input RF signal is amplified approximately 10 dB. The attenuator is selected when the ATTN IED is lit. In this selection, the RF signal is attenuated approximately 15 dB. When the NORM IED is lit, the input signal is routed in its normal path to the other circuits of the receiver.

The PREAMP selection is disabled when the receiver is tuned at or below 500 kHz. If PREAMP is selected while tuned above 500 kHz and then the receiver is tuned below 500 kHz, the preamplifier path is automatically deselected (PREAMP IED goes out) and the normal input path is automatically selected (NORM IED becomes lit). If the receiver is then tuned back above 500 kHz, the normal path is deselected (NORM IED goes out) and the preamplifier path is reselected (PREAMP IED becomes lit).

3.2.39 THE MANUAL GAIN CONTROL KNOB

The MANUAL GAIN control knob is located to the right of the RF INPUT key on the front panel. This control knob is used to adjust the manual gain of the receiver when the manual gain control is selected with the AGC key and the numerical gain value is displayed in the upper display of the Auxiliary Parameter section (refer to **paragraph 3.2.14**).

The manual gain range is from 0 to 127 dB. When this knob is set at its full counterclockwise position, minimum gain is applied to the input signal as 000 is displayed. Rotating the knob clockwise increases the gain. A full clockwise position of this knob displays 127 as the gain value and applies approximately maximum gain to the input signal.

3.2.40 THE SIGNAL LEVEL METER

The signal level meter is located between the Memory/ Scan section and the Auxiliary Parameter section on the front panel. This meter provides an indication of the power level of the signal at the current tuned frequency. The range of the meter is from -120 to +10 dBm. It should be noted that the indication on the meter is a measurement of the input signal level before attenuation or amplification is applied via the RF INPUT key.

3.2.41 THE REMOTE KEY AND LED

The REMOTE key is located below the POWER switch on the top left-hand corner of the front panel. This key is used to place the receiver in and out of Remote mode of operation. The LED in the key is lit when the receiver is in remote mode. While in the Remote mode, all front panel controls are disabled except for the REMOTE key, the PHONES and SPEAKER volume control knobs, and the POWER switch. Pressing the key while the LED is lit places the receiver in Local mode and extinguishes the LED (if remote with local lockout has not been selected over the remote bus).

3.2.42 THE POWER SWITCH

The POWER switch is a rocker-type switch located on the top left-hand corner of the front panel. This switch is used to turn the receiver on and off. When the bottom-half of the switch is pushed in, the receiver is off. Pushing in on the top-half of the switch turns the unit on and starts the power-up and initialization routine (refer to **paragraph 3.3**).

3.3 TURNING ON THE RECEIVER

The receiver is turned on when the top-half of the POWER switch is pushed in. From the off state, turning the receiver on causes it to go into its power-up and initialization routine. During initialization, the receiver lights all front panel lights with the exception of the Memory/Scan display. This display, shown below, provides the unit (WJ8711A) and the software version (Vx.xx). The Memory/Scan display performs this in receivers with internal control software versions 1.40 and later only.

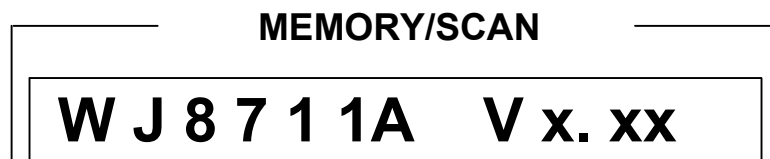

After approximately one second, initialization is complete, and the receiver automatically returns to the last selected mode, displaying the last set parameters.

The WJ8711A is equipped with battery backed-up memory. When the receiver is turned off, all current receiver parameters (including channel set-ups) are saved in memory. When the receiver is powered up, the receiver parameters that were set and displayed, prior to the receiver being turned off, are reset in the receiver and redisplayed on the displays as applicable.

3.3.1 PERFORMING A COLD START AT POWER-UP

<p>NOTE: When a cold start is performed at power-up, all setups in memory are cleared. All scan setups, memory channel contents, and receiver parameters are reset to their default conditions.</p>
--

The receiver can be cycled through a cold start at power-up. A cold start provides a means of clearing the receiver of all previous settings saved in memory and possible front panel errors. This is performed by pressing and holding the CE (clear entry) key while turning on the receiver, then releasing the CE key. At cold start power-up the MEMORY SCAN display shows "COID START" for approximately two seconds while clearing memory then goes through its normal initialization routine. When the power-up routine is completed, the auxiliary parameter displays and the tuned frequency window displays their default settings.

3.4 INTRODUCTION INTO RECEIVER OPERATIONS

To take advantage of the capabilities of the WJ8711A, it is important to gain an understanding of the general concept of its operation. Two basic modes of operation are available with the receiver: the Manual mode (SCAN key IED off) and the Scan mode (SCAN key IED on).

In the Manual mode, the receiver can be tuned to different individual frequencies by the operator, in search of signals of interest. This is the basic mode of operation. Details on the functions of the receiver in the Manual mode can be found in **paragraph 3.5**.

The Scan mode is an automatic mode of operation, where the receiver can be programmed to automatically search a band of frequencies from one frequency to another, or to step through programmed memory channels. Each memory channel contains receiver parameters such as tuned frequency, detection mode, IF bandwidth, etc. As the receiver steps to each memory channel, the receiver parameters are automatically updated with those that are stored in the memory channel until the receiver steps to the next channel. **Paragraph 3.8** provides details on Scan operations.

3.5 OPERATION IN THE MANUAL MODE

The Manual mode is used for "manually" tuning the receiver to one frequency and monitoring it for signal activity. To properly operate the receiver in the Manual mode, the following functions and parameter adjustments should be performed.

- Enter the tuned frequency.
- Select the detection mode.
- Select an IF bandwidth.
- Adjust the headphones and/or speaker volume control(s) to a comfortable level.

After the above parameters are set, the following additional actions can be taken to enhance the receiver setup to provide optimum reception of signals of interest.

- Set the squelch level.
- Select the RF input path.
- Set the gain mode to automatic (AGC) or manual (and adjust manual gain level).
- In CW detection mode, use the beat frequency oscillator (BFO) or passband tuning functions to aid in tuning to CW signals.
- In any detection mode, use the noise blanker function to blank out impulsive interference caused by sources such as automobile ignition or over the horizon radar.
- In AM, FM, ISB, USB, or LSB mode, use the Tunable Notch Filter to aid in the reduction of unwanted signals outside the passband.

The following paragraphs provide details on entering the above parameters and using the receiver enhancement features to setup the receiver in the Manual mode for optimum performance.

3.5.1 ENTERING THE TUNED FREQUENCY

In the Manual mode, the receiver monitors the frequency indicated in the **FREQUENCY** display. This frequency can be any value from 0.000000 to 30.000000 MHz, at a resolution of 1 Hz. This means that any frequency between this range can be entered. The tuned frequency can be entered and adjusted in several ways: by the tuning wheel, the ↑ (up) and ↓ (down) keys, a numeric entry, or in the step tune mode. The following paragraphs provide more information on using these methods to enter or adjust the tuned frequency.

Numeric Entry: The numeric entry keys provide for a quick means of entering a tuned frequency. When a numeric entry key is pressed, the tuned frequency display is erased and the value of the key pressed is displayed in the right most digit position. Depending on the frequency being entered, all or just the most significant digits need to be entered. For example, entering a frequency of 10 MHz only requires the following key presses:

Press 1 (the display is erased except for 1)

Press 0 (the 1 shifts left and 0 is displayed)

Press MHz (the numeric entry is terminated and the display indicates 10.000000).

The same procedure can be used for entering frequencies in the kilohertz range by terminating the numeric entry with the kHz key. When terminating the entry this way, the decimal point is automatically displayed and a 0 is displayed in the 1-MHz position.

All numeric entries for tuned frequencies must be terminated with either the kHz or MHz key. The receiver does not tune to the entered frequency until it is terminated.

Tuning Wheel: The tuning wheel can be used to dynamically adjust the tuned frequency while monitoring the audio for signals. In this tuning method, the receiver is tuning to the frequency displayed, even while the wheel is being rotated.

The tuning wheel adjusts the tuned frequency in a resolution depending on the position of the highlighted digit in the **FREQUENCY** display. For example, if the 1 kHz digit is highlighted, turning the wheel causes the

value in that position to change. When tuning up in frequency (turning the wheel clockwise), going past 9 causes the highlighted digit to display 0 and the digit to its left to increment by one (for example 0.009000 to 0.010000). When tuning down, the highlighted digit goes as far as 0 and the remaining digits remain unaffected (further counterclockwise rotation of the wheel is ignored). The position of the highlighted digit can be changed with the ← (left) and → (right) keys.

↑ and ↓

The ↑ (up) and ↓ (down) keys can be used when very small adjustments to the tuned frequency need to be made. These keys operate under the same principles as the tuning wheel, whereas they change only the highlighted value and the receiver dynamically tunes to the displayed frequency. Each press of the key causes the value to change by one.

Step Tune

The tuned frequency can also be adjusted in steps by using the tuning wheel or ↑(up) and ↓ (down) keys in the step tune mode. The step tune mode is enabled when the STEP TUNE key LED is lit. When enabled, the current step size is displayed in the Memory/ Scan display and the cursor in the FREQUENCY display disappears.

The step size can be adjusted with the Memory/ Scan edit knob. It can be any value from 0.001 kHz to 25.0 kHz. When using the ↑ and ↓ keys or the tuning wheel in the step tune mode, the tuned frequency changes in value according to the displayed step size.

3.5.2 SELECTING A DETECTION MODE

Five detection modes are available for signal demodulation: AM (amplitude modulation), SAM (synchronous amplitude modulation), FM (frequency modulation), CW (continuous wave), LSB (lower sideband), USB (upper sideband), and ISB (independent sideband). Operation with these detection modes is further described below.

- **AM Detection Mode.** In this mode, the audio present at the front panel PHONES jack and the LINE A, LINE B, SPEAKER, and DC AUDIO terminals of TB1 on the rear panel is provided by the unit's AM detector.
- **SAM Detection Mode.** Synchronous AM provides a detection mode that causes the receiver to lock on the carrier frequency in both frequency and phase. This mode improves the signal-to-noise ratio of the audio output. In addition, this mode provides greater immunity to

signal loss due to fading. The operation of the receiver in the Synchronous AM Mode can be enhanced by employing the Variable AGC Threshold feature. During instances of severe fading on AM signals, the synchronous AM demodulator attempts to synchronize itself to the distorted fading signal. Loss of signal lock may occur in some cases. By using the Variable AGC Threshold feature, the operator can reduce the gain applied to the faded signal so that it will be too weak to force the synchronous AM demodulator out of lock.

- **FM Detection Mode.** In this mode, the audio present at the front panel PHONES jack and the LINE A, LINE B, SPEAKER, and DC AUDIO terminals of TB1 on the rear panel is provided by the unit's FM detector.
- **CW Detection Mode.** In this mode, the audio present at the front panel PHONES jack and the LINE A, LINE B, SPEAKER, and DC AUDIO terminals of TB1 on the rear panel is provided by the unit's CW product detector. In this mode, BFO and passband tuning operations can be used.
- **LSB Detection Mode.** In this detection mode, only IF bandwidths from 900 Hz to 3.2 kHz are selectable. Upper sideband audio is provided at the front panel PHONES jack and the LINE A, LINE B, SPEAKER, and DC AUDIO terminals of TB1 on the rear panel. The BFO frequency cannot be altered or displayed in this mode.
- **USB Detection Mode.** Except for the sideband selected, this mode is functionally identical to the LSB detection mode.
- **ISB Detection Mode.** In this detection mode, only IF bandwidths from 1.8 kHz to 3.2 kHz are selectable. Both upper and lower sidebands are separately and simultaneously demodulated. ISB audio is provided on the left channel of the PHONES jack while USB audio is provided on the right channel. USB audio is provided on the LINE A terminal of TB1 while ISB audio is provided on the LINE B terminals. The audio available at the SPEAKER terminals of TB1 is dependent on the setting of the front panel SPEAKER switch. When BOTH is selected, ISB and USB audio is combined and provided at the output. When ISB or USB are selected only the respective audio is provided at the output.

The detection mode is selected with the DET MODE key located in the Auxiliary Parameter section of the front panel. The currently selected detection mode is displayed in the lower auxiliary parameter display, directly above the DET MODE key.

To select a different detection mode, press the DET MODE key so that its IED becomes lit. Then use either the Auxiliary Parameter edit knob or continue pressing the DET MODE key until the desired detection mode is displayed.

3.5.3 SELECTING AN IF BANDWIDTH

Sixty-six (66) intermediate frequency (IF) bandwidths are available for selection (see **Table 1-1** for a list of available IF bandwidths). The IF bandwidth is selected with the IF BW key located in the Auxiliary Parameter section of the front panel. The currently selected IF bandwidth is displayed in the lower auxiliary parameter display, directly above the IF BW key.

To select a different IF bandwidth, press the IF BW key so that its IED becomes lit. Then use either the auxiliary parameter edit knob or continue pressing the IF BW key until the desired IF bandwidth is displayed. Only those bandwidths that are set to "include" using the IF Bandwidth Select mode (see **paragraph 3.5.3.1**) will be available for selection.

NOTE: In the USB or LSB detection modes, only IF bandwidths from 900 Hz to 3.2 kHz are selectable. In the ISB detection mode, only IF bandwidths from 1.8 kHz to 3.2 kHz are selectable.

INCLUDING AN IF BANDWIDTH FILTER FOR SELECTION

Any of the 66 available IF bandwidth filters can be included for selection by the receiver. The IF Bandwidth Select mode is used to "include" or "skip" the desired IF bandwidth in the list of available filters.

The IF Bandwidth Select mode is enabled by pressing the SPECIAL FUNCTION key until the upper Auxiliary Parameter display appears as follows.

IF BW SELECT

The currently selected IF bandwidth is displayed in the lower Auxiliary Parameter display along with the word "include" or "skip". When "include" is displayed, the identified bandwidth will be included in the available IF bandwidth list used for making IF bandwidth selections as described in **paragraph 3.5.3**. If "skip" is displayed, the identified bandwidth will not be available for selection.

Once in the IF Bandwidth Select mode, each of the 66 IF bandwidth filters can be set to "include" or "skip" as desired. To set a filter for "include", first select the desired IF bandwidth by rotating the Auxiliary Parameter edit knob until that bandwidth is displayed in the lower Auxiliary Parameter display. Each press of the IF BW key toggles the status of the selected filter from "include" to "skip".

3.5.4 SETTING THE SQUELCH LEVEL

The squelch can be adjusted to a level, depending on the strength of the signals being received. If a signal is received that is not quite strong enough for proper demodulation (i.e., its audio is unclear), the squelch level can be adjusted to block it from being applied to the audio outputs. The squelch should be set to a level where it does not block clear signals but does block noisy unwanted signals. Several adjustments may have to be made to find the optimum level. Only signals that have a power level above the set squelch level will be provided at the audio outputs.

The current squelch level is displayed in the lower auxiliary parameter display, directly above the SQUELCH key. The range of the squelch level is 0 to -135 dBm or can be set to off ("- -"). The squelch level can be adjusted by first pressing the SQUELCH key to light its LED and to enter the squelch entry mode. The value can be altered by the Auxiliary Parameter edit knob or by pressing the SQUELCH key to toggle between off and a numeric value. The numeric entry keys can be used to enter a numeric value in units of dBm, terminated with the SQUELCH key.

Terminal 12 (MUTE) of TB1 on the rear panel is provided for the input of external squelch control in system setups. When an external mute is asserted (mute line pulled low), the receiver's squelch is activated and the squelch value in the display is overwritten with "MUT". When the external mute is disasserted (mute line pulled high or not driven), the display returns to the last squelch value that was selected.

3.5.5 ATTENUATING OR AMPLIFYING INPUT SIGNALS VIA THE RF INPUT PATH SELECTION

Depending on the receiver's tactical location, signals may be, in general, too powerful or not powerful enough for ideal reception. In these situations the input signals can be attenuated or amplified by selecting the appropriate RF input path for the input signals. The RF INPUT key is used to make the selection, which can be PREAMP, NORM, or ATTN. The selection is indicated by the lit LED.

When PREAMP is selected, all input signals are amplified by 10 dB. When ATTN is selected, all input signals are attenuated by 15 dB. When NORM is selected, the input signals are unaffected at this point.

3.5.6 SELECTING THE GAIN CONTROL MODE

Three modes of AGC are available: fast, medium, and slow. The fast AGC mode provides a 15-millisecond (ms) attack time and a variable (in 10-ms increments) decay time from 10 ms to 100 ms. The medium AGC mode provides a 15-ms attack time and a variable (in 100-ms increments) decay time from 100 to 1000 ms. The slow AGC mode provides a 15-ms attack time and a variable (in 500-ms increments) decay time from 1 second to 5 seconds. Attack time and decay time are defined as the respective lengths of time that it takes for the audio outputs to return to a nominal level after a moderate instantaneous increase or decrease in the input signal level.

The selected gain mode is displayed in the upper Auxiliary Parameter display, directly above the AGC key. The selections are FST (for fast AGC), MED (for medium AGC), SLO (for slow AGC), and MAN (for manual gain control). To select the gain control mode, press the AGC key, lighting its LED. Use the Auxiliary Parameter edit knob or continue pressing the AGC key until the desired mode is displayed.

In the manual gain mode (MAN), the operator can manually adjust the gain of the receiver with the MANUALGAIN knob.

3.5.7 AIDING CW DETECTION WITH THE BFO FUNCTION

The BFO (beat frequency oscillator) function is available, while in the CW detection mode, to aid in the detection of CW tones. A BFO frequency can be applied to the received CW signal to alter its audio pitch.

The BFO frequency ranges from -8000 Hz to +8000 Hz with 10-Hz resolution. For example, if the tone of the received CW signal is at 5,000 Hz, entering a BFO frequency of -1000 Hz would change the CW tone heard at the audio outputs to 4,000 Hz. Conversely, entering a BFO frequency of +1000 Hz would change the CW tone to 6,000 Hz.

The current BFO frequency is displayed in the upper Auxiliary Parameter display, directly above the BFO keys. To change the BFO frequency, first press the BFO key to light the LED and enable the BFO parameter entry mode. The parameter can then be adjusted with the Auxiliary Parameter edit knob or can be overwritten with a new value by using the numeric entry keys.

The +/- ZERO key is used to change the sign of the frequency to positive or negative, or can be used to automatically set the BFO to zero. Continue pressing this key until the positive (+) or negative (-) sign is displayed or until 0000 is displayed as desired.

3.5.8 PASSBAND TUNING IN CW DETECTION MODE

The passband tuning function is available only while the receiver is in the CW detection mode. This function has the effect of shifting the IF bandwidth without changing the frequency of the audio output signals so that unwanted CW signals can be placed outside of the IF bandwidth while keeping the wanted CW signals inside the bandwidth. This is especially useful in FSK demodulation applications for monitoring mark and space frequencies while other CW signals close in frequency are present.

The passband tuning parameter can be any value from -2000 to +2000 Hz in 10-Hz steps. When the passband tuning function is used, the tuned frequency and BFO frequencies are adjusted in accordance to the entered passband tuning parameter. The BFO frequency counteracts the effect of the tuned frequency, which allows the output audio tones to remain at the previously adjusted frequencies. For example, entering a passband tuning parameter of +1000 shifts the tuned frequency up by 1000 Hz which also shifts the IF bandwidth. Any signals received within the IF bandwidth are applied with a BFO offset frequency of -1000 Hz which brings the demodulated tone back down to its original audio frequency.

The passband tuning mode is entered by pressing the SPECIALFUNCTION key until the upper Auxiliary Parameter display appears as follows:

P B T U N s n n n n
 Hz mSec

where "s" is the positive (+) or negative (-) sign and "nnnn" is the offset frequency. The Auxiliary Parameter edit knob can be used to adjust the parameter.

NOTE: The passband tuning parameter is reset to zero (0000) when the CW detection mode is deselected or whenever the tuned frequency is changed while the passband tuning parameter is not currently displayed.

3.5.9 BLANKING OUT NOISE IN INTERFERENCE

The WJ8711A is equipped with a noise blanker function. This function can be used to "blank" impulsive interference at the tuned frequency. Common interferences such as "popping" from ground radar waves can be blanked for a period of time, keeping them from being demodulated and heard at the audio outputs. The noise blanker can be any value from 1 to 10 or can be set to off. The higher the noise blanker value, the more noise blanking is applied. The noise blanker can be adjusted while listening to the received audio, and setting the noise blanker to a value that is just long enough to blank the noise but no longer.

The current noise blanker setting is displayed in the upper Auxiliary Parameter display, directly above the BLANKER key. To adjust the setting, first press the BLANKER key to light its LED and enable the noise blanker entry mode. The value can be adjusted with the Auxiliary Parameter edit knob or can be overwritten with a numeric entry, terminated by pressing the BLANKER key.

3.5.10 USING THE TUNABLE NOTCH FILTER

The Tunable Notch filter function is available, while in the AM, FM, USB, LSB, ISB, SAM, and FSK detection modes, to aid in the reduction of unwanted signals outside the passband. The relative position of the tunable Notch Filter can be adjusted to ± 9999 Hz from the tuned carrier frequency, however, each available IF bandwidth filter has its own limits. **Table 3-1** lists the possible IF bandwidths available and their respective tunable notch filter range.

The current notch filter setting is displayed in the upper Auxiliary Parameter display.

The +/- ZERO key is used to set the relative direction above or below the carrier frequency the tunable notch filter tunes. Selections of above (>) or below (<) the tuned carrier frequency, and OFF are toggled with each press of the +/- ZERO key. Once the desired direction (>) or (<) is selected, the position of the notch filter can be adjusted with the Auxiliary Parameter edit knob, or by using the numeric entry keys.

3.6 STORING CURRENT RECEIVER PARAMETERS IN MEMORY

The receiver parameters that are currently displayed can be stored in a memory channel of the receiver for later recall and use. The current tuned frequency and all auxiliary parameters are stored. To store the current receiver parameters, first select the Channel View mode by pressing the CHANNEL VIEW key and lighting its LED. Use the Memory/ Scan edit knob, or perform a numeric entry terminated with the CHANNELVIEW key, to display a vacant memory channel or a memory channel that has old data that can be overwritten. Unstored memory channels have a default frequency value of 20.00000 MHz.

NOTE: Storing receiver parameters in a memory channel overwrites its previous contents. Ensure, before storing data, that the memory channel does not contain wanted data.

Table 3-1. Tunable Notch Filter Range

IF Bandwidth (kHz)	Maximum Relative Setting from the Tuned Carrier Frequency
.056, .063, .069 .075, .081, .088 .094, .100	±97 Hz
.113, .125, .138, .150, .163, .175, .188, .200	±195 Hz
.225, .250, .275 .300, .325, .350, .375, .400	±390 Hz
.450, .500, .550, .600, .650, .700, .750, .800	±781 Hz
.900, 1.000, 1.100, 1.200, 1.300, 1.400, 1.500, 1.600	±1562 Hz
1.800, 2.000, 2.200, 2.400, 2.600, 2.800, 3.000, 3.200	±3125 Hz
3.600, 4.000, 4.400, 4.800, 5.200, 5.600, 6.000, 6.400	±6250 Hz
7.200, 8.000, 8.800, 9.600, 10.400, 11.200, 12.000, 12.800, 14.400, 16.000	±12500 Hz

NOTE: The WJ8711A software will allow tunable notch filter settings of ±9999 Hz in all IF bandwidths. However, settings outside the specified maximum limit for each bandwidth will automatically disable the tunable notch filter

Once the desired memory channel is displayed, press the **STORE** key. This causes the new stored frequency to be displayed for three seconds in the Memory/ Scan display and the channel number to be prefixed with an "i" (example "i45 15.42700"). After three seconds, the channel number automatically increments to the next memory channel.

3.7 CHANGING RECEIVER PARAMETERS TO THOSE STORED IN A MEMORY CHANNEL

The receiver parameters can be automatically updated with receiver parameters that are stored in one of the memory channels. To perform this function, press the **CHANNEL VIEW** key to enter the Channel View mode. Use the Memory/ Scan edit knob, or perform a numeric entry terminated with the **CHANNEL VIEW** key, to display the memory channel that contains the desired parameters. Once the memory channel is displayed, press the **CHANNEL EXECUTE** key. This lights the key's LED and updates the receiver with the parameters of the memory channel.

While the **CHANNEL EXECUTE** key LED is lit, the memory channel number can be changed because the Channel View mode is still enabled. (Pressing the **CHANNEL EXECUTE** key automatically enables the Channel View mode if not already enabled.) Changing the memory channel number while channel execute is enabled causes the receiver parameters to be automatically updated as each new channel is selected and displayed. Channel execute can be exited by pressing the **CHANNEL EXECUTE** key again, extinguishing its LED.

3.8 OPERATION IN THE SCAN MODE

The Scan mode is an automatic mode of operation, where the receiver can be preprogrammed to search a band of frequencies or step through individual frequencies for signal activity. Three types of scan operations are available in the Scan mode: channel scanning, frequency-to-frequency scanning, and frequency-to-frequency scanning with lockout frequencies inserted.

In the channel scan mode, the receiver is programmed to scan from a start channel to a stop channel. The channels are memory channels that contain receiver parameters, stored with the **STORE** key (**paragraph 3.6**). In this mode the receiver steps from channel to channel beginning with the start channel and ending with the stop channel. As the receiver steps to each channel it automatically changes its parameters to those stored in the channel. If a signal is not received in the current channel, it moves to the next channel. When the stop channel is reached, the receiver steps to the start channel and continues scanning.

In the frequency-to-frequency scan mode, the receiver is programmed to scan all frequencies between and including a start frequency and a stop frequency. If a signal is found, the scan mode stops and displays the current frequency. The amount of time the scan mode stops on a received signal is dependent on the dwell timer entry (**paragraph 3.8.1**). When the stop frequency is reached the receiver steps to the start frequency and continues scanning.

The frequency-to-frequency scan mode with lockout frequencies inserted operates identically to the frequency-to-frequency scan mode. However, in this mode the operator can enter frequencies that are to be passed over during the scan sequence and not searched for signal activity. These frequencies are referred to as lockout frequencies.

The following paragraphs provide details on the use of the dwell timer, entering scan setups, starting scans, and stopping scans.

3.8.1 USING THE DWELL TIMER

The dwell timer provides the operator with a means of controlling the time the receiver remains tuned on a signal received in the Scan mode before moving to the next frequency or channel. The dwell timer is activated when a signal that has a power level above the set squelch level is received.

The dwell timer can be set to any value from 0.5 to 20.0 seconds or can be set to infinite. When the timer expires, the scan operation automatically resumes whether or not the signal is still above squelch. When the timer is set to infinite, the receiver continues to dwell on the signal until either it drops below the squelch level for a period of eight seconds or until the operator manually restarts the scan.

If the signal drops below the squelch level for a period of eight seconds while the timer is activated, the scan automatically resumes regardless if the timer has not yet expired.

The dwell timer value can be entered in the scan setup menu (**paragraph 3.8.2**) or can be adjusted during an active scan with the DWELL key. When using the DWELL key to adjust the value, the dwell timer value is automatically adjusted in the setup menu for the current active scan.

3.8.2 SCAN SETUPS

Prior to initiating the Scan mode, a scan setup must be entered. To enter a scan setup, first press the SCAN SETUP key to enable the scan setup entry mode. This mode is enabled when the LED in the SCAN SETUP key is lit. A line item of the current scan type setup menu is displayed in the Memory/Scan display. The scan type setup menu that is displayed is dependent on the lighting of the SCAN TYPE LEDs.

Three scan type setups menus are available: channel (CHANNEL SCAN TYPE LED lit), frequency-to-frequency (F1 → F2 SCAN TYPE LED lit), and frequency-to-frequency with lockout frequencies inserted (F1 → F2 w/ LOCK SCAN TYPE LED lit). The following paragraphs provide details on these scan setups.

CHANNEL SCAN SETUP

Channel scan setups can be entered when the SCAN SETUP key LED is lit and the CHANNEL SCAN TYPE LED is lit. In this setup menu, three items can be entered: the start channel, the stop channel, and the dwell time.

Start Channel: The start channel entry signifies the lowest channel number of the setup. To enter the start channel, first use the edit knob or press the SCAN SETUP key until "START CHA xx" is displayed. The xx is replaced with the current start channel number. Use the numeric entry keys to enter the new start channel and terminate with the SCAN SETUP key.

Stop Channel: The stop channel entry signifies the highest channel number of the setup. To enter the stop channel, first use the edit knob or press the SCAN SETUP key until "STOP CHA xx" is displayed. The xx is replaced with the current stop channel number. Use the numeric entry keys to enter the new stop channel and terminate with the SCAN SETUP key.

Dwell Time: The dwell timer value (*paragraph 3.8.1*) can be set in the channel scan setup menu. To enter the dwell timer value, first use the edit knob or press the SCAN SETUP key until the dwell timer menu item is displayed. The menu item may appear as "DW L IN FINITE" or "DW ELL xx.x s" where xx.x is the current dwell timer value in seconds. Use the numeric entry keys to enter the dwell timer value and terminate with the SCAN SETUP key. The dwell timer cannot be set to DW L IN FINITE in the scan setup menu; use the DW ELL key.

Each channel in the scan setup should be designated with an "include" or "skip" status. If all channels within the scan setup are to be scanned they should be in the "include" status. The "include" status for a channel is indicated by the channel number being prefixed with "i". If the channel within the scan setup is not to be scanned, it should be set to the "skip" status. The "skip" status for a channel is indicated by the channel number being prefixed with an "s". Use the channel view mode to review the status of each channel within the scan setup. Use the CHANNEL SKIP key or the CHANNEL INCLUDE key to select the desired status when the channel is displayed.

Foldout FO-3 provides an example of setting up and executing a channel scan operation.

FREQUENCY-TO-FREQUENCY

(F1 → F2) SCAN SETUP

Frequency-to-Frequency scan setups can be entered when the SCAN SETUP key LED is lit and the F1 → F2 SCAN TYPE LED is lit. In this setup menu, four items can be entered: the start frequency, the stop frequency, the step size, and the dwell time.

Start Frequency: The start frequency entry signifies the first frequency of the scan sequence. To enter the start frequency, first use the edit knob or press the SCAN SETUP key until "F1 xx.xxxxxx" is displayed. The xx.xxxxxx is replaced with the current start frequency in MHz. Use the numeric entry keys to enter the new start frequency and terminate with the SCAN SETUP key.

Stop Frequency: The stop frequency entry signifies the last frequency of the scan sequence. To enter the stop frequency, first use the edit knob or press the SCAN SETUP key until "F2 xx.xxxxxx" is displayed. The xx.xxxxxx is replaced with the current stop frequency in MHz. Use the numeric entry keys to enter the new stop frequency and terminate with the SCAN SETUP key.

Step Size: The step size entry determines the frequency steps in the scan. The step size can be any value from 0.001 to 25.0 kHz. To enter the step size, first use the edit knob or press the SCAN SETUP key until "STEP xx.xxxx" is displayed. The xx.xxxx is replaced with the current step size in kHz. Use the numeric entry keys to enter the new step size and terminate with the SCAN SETUP key.

Dwell Time: The dwell timer value (*paragraph 3.8.1*) can be set in the frequency-to-frequency scan setup menu. To enter the dwell timer value, first use the edit knob or press the SCAN SETUP key until the dwell timer menu item is displayed. The menu item may appear as "DWL INFINITE" or "DWELLxx.x s" where xx.x is the current dwell timer value in seconds. Use the numeric entry keys to enter the dwell timer value and terminate with the SCAN SETUP key. The dwell timer cannot be set to INFINITE in the scan setup menu; use the DWELL key.

Foldout FO-4 provides an example of setting up and executing an F1 → F2 scan operation.

**FREQUENCY-TO-FREQUENCY WITH
LOCKOUTS (F1 → F2
W/ LOCK) SCAN SETUP**

Frequency-to-frequency with lockouts scan setups can be entered when the SCAN SETUP key LED is lit and the F1 → F2 w/ LOCK SCAN TYPE LED is lit. This setup menu is the same as the frequency-to-frequency setup menu (*paragraph 3.8.2.2*) except a list containing up to 100 lockout frequencies is available. When scanning in this mode, all frequencies entered in the list are passed over.

A lockout frequency can be added to the list during a paused scan by setting the tuned frequency display to the desired frequency, then press the FREQUENCY LOCKOUT key. The scan setup display does not have to be entered to store a new lockout frequency. After the lockout frequency is stored, the message "LOCKOUT STORED" is displayed for a period of three seconds, after which time the Memory/ Scan display returns to the previous display. If no lockout channels are available (i.e., 100 lockouts are already entered), the message "MEMORY FULL" is temporarily displayed.

A lockout frequency can also be deleted from the list. To delete a lockout, scroll through the scan setup display until the lockout frequency is displayed, then press the CLEAR key.

Foldout FO-4 provides an example of setting up and executing an F1 → F2 scan operation including steps for entering and clearing lockout frequencies.

3.8.3 PLACING THE RECEIVER IN SCAN MODE

Once a scan setup has been entered, the receiver can be placed into the scan mode. To start a scan, first select the type of scan with the SCAN TYPE key, then press the SCAN key. The scan is started when the SCAN key LED is lit.

<p>NOTE: When the channel scan is started, both Auxiliary Parameter displays are blanked until a signal is acquired.</p>

3.8.4 PAUSING AND RESTARTING SCANS

An active scan operation can be paused by pressing the PAUSE key. When the scan is paused, the PAUSE key LED is lit and the displays indicate the current tuned frequency and auxiliary parameters of the receiver. The scan can be restarted by pressing the PAUSE key again, extinguishing its LED. When a paused scan operation is restarted, the scan operation resumes at the next step in the scan sequence after which it was paused. For example, when a channel scan operation is paused, the

channel to which the receiver is currently tuned is displayed. When the scan is restarted the scan resumes at the next channel in the scan sequence.

When paused, the receiver acts as if it is in the Manual mode. Receiver parameters can be adjusted to look more closely at a received signal. When a scan is restarted, tuned frequency adjustments are ignored and the scan resumes according to the programmed scan setup. However, changes and adjustments to auxiliary parameters are maintained.

Also, when paused, scan setup parameters can be changed. Lockout frequencies can be added with the **FREQ UEN CY IO CKO UT** key or can be deleted in the scan setup menu. The step size can be changed with the **STEP SIZE** key or in the scan setup menu.

3.9 RUNNING THE BUILT-IN-TEST FUNCTION (BITE)

The built-in-test function (BITE) provides the operator the capability of testing the internal circuitry of the receiver. A passed BITE test provides confidence that the receiver is performing normally.

To start BITE, first press the **SPECIAL FUNCTION** key until the message "BITE PENDING" is shown in the upper Auxiliary Parameter display. Then turn the Auxiliary Parameter edit knob in either direction; all LEDs are lit while BITE is being run.

The BITE result takes the form of a decimal number, equivalent to a 16-bit binary number. Sixteen tests are performed during the BITE routine. A failed test sets its corresponding bit in a 16-bit register table. The tests and their corresponding bits of the register table are listed in **Table 3-2**.

Table 3-2. BITE Error Codes

Bit	Decimal Value	Error Indication
0 (ISB)	1	Transmit Error - the control to DSP transmit pipeline is not empty.
1	2	Host Download Unsuccessful - the host microprocessor could not download the operating program.
2	4	EPROM Download Unsuccessful - the download to EPROM could not be completed.
3	8	Host Command Not Acknowledged - the DSP processor could not acknowledge the start-up command from the host microprocessor.

Table 3-2. BITE Error Codes (Continued)

Bit	Decimal Value	Error Indication
4	16	No Response Back From the Host Processor - the DSP processor did not receive a response back from the host microprocessor.
5	32	DSP Memory Check Not Completed - the check of the DSP processor's internal memory could not be completed.
6	64	DSP EPROM Failure - the DSP processor's internal EPROM could not be accessed.
7	128	DSP SRAM Failure - the DSP processor's internal static RAM could not be accessed.
8	256	RF Test Failed - the RF front end is not functioning properly.
9	512	Host A/D Failure - the host microprocessor's internal analog-to-digital converter is not functioning properly.
10	1024	Non-SSB Audio Failure - the AM, FM, CW demodulated audio path not functioning properly.
11	2048	USB Audio Failure - the upper sideband (USB) demodulated audio path not functioning properly.
12	4096	USB Audio in LSB Path Failure - the lower sideband (LSB) audio path not functioning properly with upper sideband (USB) audio.
13	8192	LSB Audio Failure - the lower sideband (LSB) demodulated audio path not functioning properly.
14	16384	LSB Audio in USB Audio Path Failure - the upper sideband (USB) audio path not functioning properly with lower sideband (LSB) audio.
15 (MSB)	32768	DSP A/D Failure - the DSP processor's analog-to-digital converter is not functioning properly.

The combination of set bits will determine the BITE result number. If all tests passed, the BITE result displayed will be "BITE PASS". If BITE PASS is not displayed, and error has occurred. For example, if bits 0 and 3 were set because their corresponding tests failed, the BITE result displayed will be "BITE 009" (binary equivalent 00000000 00001001). If an error is encountered, the operator may attempt to turn the receiver's power off then back on from a cold start to rerun the BITE function. If an error persists, a hardware failure has been encountered.

3.10 DISPLAYING THE RECEIVER'S CURRENT INTERNAL CONTROL SOFTWARE VERSION

To display the receiver's current internal control software version turn the POWER switch off and then on. The receiver goes through its initialization routine and displays the unit's current internal control software version in the Memory/Scan display. The internal control software version is displayed for approximately one second. The Vx.xx indicates the current software version.

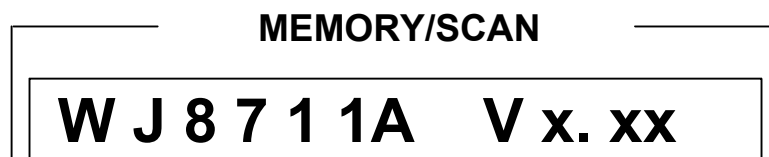

This function is only available in units with internal control software version 1.40 and later.

3.11 SETTING REMOTE OPERATION CONFIGURATIONS FROM THE FRONT PANEL

From the front panel the local operator can select several remote operation configurations: RS-232 or CSMA remote operation selection, baud rate selection, and receiver address selection for CSMA remote operation. The following paragraphs provide details on performing these configurations.

NOTE: The receiver only recognizes remote configuration changes when power is cycled off and back on. After making any remote configuration changes, turn the receiver off then back on to set the new configuration in the receiver.

3.11.1 SELECTING THE RS-232 OR THE CSMA INTERFACE FOR REMOTE OPERATIONS

The interface to be used for receiver remote operation can be selected from the front panel by pressing the SPECIAL FUNCTION key until the message "REMOTE xxxxx" is displayed in the upper Auxiliary Parameter display. The xxxxx is replaced with the current selection, either "RS232" or "CSMA". Use the Auxiliary Parameter edit knob to display the desired remote interface. This selection overrides the selection made with DIP switch A2S1 (see **paragraph 2.2.5**). Refer to **Section 4** of this manual for details on RS-232 remote operations or to **Section 5** for details on CSMA remote operations.

3.11.2 SELECTING THE BAUD RATE FOR REMOTE OPERATIONS

The baud rate for RS-232 and CSMA remote operations can be selected from the front panel by pressing the SPECIAL FUNCTION key until the message "BAUD xxxx" is displayed in the upper Auxiliary Parameter display. The available baud rates are 75, 150, 300, 600, 1200, 2400, 4800, and 9600 bps. Use the Auxiliary Parameter edit knob to display the desired baud rate. The baud rate selected applies to both RS-232 and CSMA remote operations (separate baud rate selections are not available). This selection overrides the selection made with DIP switch A2S1 (see **paragraph 2.2.5**).

3.11.3 SELECTING THE RECEIVER'S ADDRESS FOR CSMA REMOTE OPERATIONS

The address of the receiver for CSMA remote operations can be selected at the front panel by pressing the SPECIAL FUNCTION key until the message "ADDRESS xx" is displayed in the upper Auxiliary Parameter display. The "xx" is replaced with the current address selection. The CSMA address selection is available only while CSMA is selected for remote operations (refer to **paragraph 3.11.1**).

The CSMA address for the receiver can be any number from 1 to 63 (0 is reserved). Use the Auxiliary Parameter edit knob to select and display the desired address number. This selection overrides the selection made with DIP switch A2S2 (see **paragraph 2.2.5**).

SECTION 4

RS-232 REMOTE OPERATION

THIS PAGE INTENTIONALLY LEFT BLANK

SECTION 4

RS-232 REMOTE OPERATION

4.1 INTRODUCTION

The WJ8711A Digital HF Receiver has the built-in capability of being controlled remotely by a computer or other controller device that is equipped with an RS-232 serial interface and capable of transmitting and receiving ASCII-standard encoded characters. Physically, the controller device needs only a transmit line (TXD), a receive line (RXD), and a ground line to communicate with the receiver.

The WJ8711A can be set for RS-232 remote control by selecting "RS232" in the remote control entry mode with the front panel SPECIAL FUNCTION key. The baud rate can also be selected in an entry mode entered with this key. Refer to **paragraph 3.10** for details on using the SPECIAL FUNCTION key to configure the receiver for remote operation. Switch 4 of DIP switch A2S1 can be set to the off (up) position to activate the RS-232 remote control. A baud rate hardware default can also be selected. Refer to **paragraph 2.2.5** for details on configuring DIP switch A2S1.

Various receiver parameters can be controlled and/ or monitored over the RS-232 interface. These parameters are:

- tuned frequency,
- BFO frequency,
- detection mode,
- squelch level,
- speaker type,
- IF bandwidth,
- gain mode,
- built-in-test (BITE) execution,
- error status (both current and latched),
- selection of local control, remote control, or remote control with local lockout,
- selection of F1-to-F2 scan start and stop frequencies,
- selection of channel scan start and stop channels,
- passband tuning offset frequency,
- recall stored parameters from
- tunable notch filter adjustment
- external reference,
- signal strength,
- squelch status,
- mute status,
- receiver identity,
- manual gain,
- signal dwell time,
- blanking,
- selection of channel scanning, F1-to-F2 scanning, or F1-to-F2 scanning with local lockouts,
- selection of F1-to-F2 scan increment,
- selection of frequency lockouts,
- store front panel parameters to selected memory channel, and
- current WJ8711A operating parameters,
- current internal control software version

This section of the manual contains all the information necessary to enable an operator to control and monitor the above receiver parameters from an RS-232 controller. Details on how to properly format and transmit remote messages and how to read responses from the receiver are provided.

Before attempting to operate the receiver remotely, it is recommended that the operator become familiar with the operation and capabilities of the receiver by viewing the information provided in **Section III** of this manual. It is also recommended that the operator become familiar with the operation of the controller by viewing its literature.

4.2 INTERFACING WITH THE WJ-8711A

The RS-232 interface of the WJ-8711A is physically implemented on the RS-232 connector (A2B), located on the rear panel. This interface has a full duplex operation, meaning that it can transmit and receive data simultaneously. The interface is set up as a "three-wire" RS-232 configuration, implemented on the transmit data line (TXD), the receive data line (RXD), and ground. These three wires are provided at the rear panel RS-232 connector on pins 2, 3, and 7, respectively.

This interface supports software handshaking only, including XON/XOFF (receiver protocol) and ACK/NAK (transmitter protocol). Hardware handshake signals such as RTS (request to send), CTS (clear to send), DTR (data terminal ready), or DSR (data set ready) are not supported.

RS-232 serial interfaces use a method of transmitting data one bit at a time over the TXD and RXD lines. For example, an eight-bit character takes eight sequential transmissions to complete the character. In RS-232 serial transmissions, data is sent in frames (or packets). Each bit within the frame is determined by a voltage level. The voltage levels used by this interface are -8 Vdc (nominal) for a logic "1" and +8 Vdc (nominal) for a logic "0". In the inactive or quiet state, the transmit line is held at a logic 1.

The baud rate (rate of data flow in bits per second) for the WJ-8711A is selectable (75, 150, 300, 600, 1200, 2400, 4800, or 9600 bps). Refer to **paragraph 3.10** for details on selecting the baud rate with the SPECIALFUNCTION key. Switches 1, 2, and 3 of DIP switch A2S1 can be set to appropriate positions to select the hardware default baud rate. Refer to **paragraph 2.2.5** in **Section II** of this manual for details on configuring DIP switch A2S1.

The WJ-8711A is set up with a fixed data word frame format consisting of ten bits, and comprised of the following:

- one start bit,
- an eight-bit character, and
- one stop bit.

It is important in serial data transmissions that the receiving device knows when data is being transferred and when data being transferred is about to stop. This information is conveyed by the above start and stop bits. The start bit synchronizes the receiving device so it reads the data properly. The stop bit notifies the receiving device that the data frame has ended. The WJ8711A's fixed data word frame format does not contain a parity bit.

4.3 COMMAND MESSAGE FORMATTING

Command messages for the WJ8711A are exclusively ASCII-encoded data, consisting of command headers and arguments. Command headers consist of three character mnemonics. All queries consist of a command header, followed by a question mark (?). All command arguments are in the "forgiving" numerical representation form (refer to **paragraph 4.3.3**).

Command messages are divided into two categories: receiver device messages and communication messages. Refer to **paragraphs 4.4** and **4.5** respectively.

Multiple commands may be sent to the receiver at once by transmitting them as a string. All commands in the string must be separated by a semicolon (;) (i.e., DET 1;BW S 4).

4.3.1 TERMINATORS FOR COMMANDS AND QUERIES

Terminators are used to signal the end of a command or string. When a properly formatted message is ready to be sent, a LF (line feed) character should be entered. The LF character instructs the receiver to process the preceding message(s).

The WJ8711A also transmits a terminator when responding to queries. After the query response is transmitted the receiver issues a CR,LF (carriage return, line feed characters), indicating end of response.

4.3.2 FORMATS OF QUERY RESPONSES

The WJ8711A transmits responses to queries in a fixed-field format. Query responses begin with the three-letter mnemonic of the query in upper-case characters, followed by a numeric argument. In all query responses, the mnemonic and argument are separated by a space. Numeric arguments are represented by the least number of digits possible, while still representing the entire range of the value. If a negative value is allowed for the argument, a positive or negative sign is always given. Responses due to multiple queries are linked together in a query string, with each query and its argument separated with a semicolon from other queries in the string. The WJ8711A terminates all responses to single queries or query strings with the CR (carriage return) and LF (line feed) characters.

4.3.3 REPRESENTATION OF NUMERIC ARGUMENTS

Arguments for commands and queries in this manual are represented by an nrX (where X is either f, 1, or 2). The nrf representation is used for command numeric arguments. The nr1 and nr2 are used for the representation of query response arguments.

Numeric arguments that are used with commands are accepted in a forgiving numeric representation (nrf). This implies that the WJ8711A is a forgiving listener. Specific details on numeric representation are given below.

- nrf - The nrf (forgiving numeric representation) data element for commands is composed of the sequential fields listed below. All fields (1-5) are optional with one restriction: at least one digit must be present with the active data element of the argument.

<u>Field</u>	<u>Data</u>
1	Plus (+) or minus (-) sign.
2	Any number of digits, up to eight.
3	A decimal point (.).
4	Any number of digits, up to eight.
5	An upper-case "E" or lower-case "e" followed by an optional sign and at least one digit but no more than two digits.

If the WJ8711A receives an nrf of a precision greater than it can handle, it rounds the number rather than truncating it. When rounding, the unit ignores the sign of the number and rounds up on values greater than or equal to one half. It rounds down on values less than one half.

- nr1 - The nr1 is a numeric query response data format for integers, composed of an optional sign field, followed by any number of digits. The decimal point is implicitly defined to always follow the last digit and is therefore, not present in the response data element.
- nr2 - The nr2 numeric response data format is composed of an optional sign field, followed by any number of digits, a decimal point, and any number of digits. At least one digit is always present on both sides of the decimal point.

4.4 RECEIVER DEVICE MESSAGES

Receiver Device Messages are commands that affect the operational parameters of the receiver. These commands are listed in **Table 4-1**.

Table 4-1. Receiver Device Messages

Command	Response	Description
ADV		Advance to next scan frequency. Operates when WJ8711A is in dwell mode during scan.
AGC nrf		Select gain control mode. Range: 0 - 3 Where: 0 - Manual 1 - Slow AGC 2 - Fast AGC 3 - Medium AGC
AGC?	AGC nr1	Request active gain control mode. Reset: AGC 2 Default: AGC 2 Example: AGC 0
AGD nrf nrf		Set decay time for gain control modes. Where: 1 - Slow AGC 2 - Fast AGC 3 - Medium AGC If Slow AGC, time range is 1000 to 5000 (rounds up to next lower 500 millisecond step) If Fast AGC, time range is 10 to 100 (round to next lower 10 millisecond step) If Medium AGC, time range is 100 to 1000 (round to next lower 100 millisecond step)
AGD? nrf	AGD nr1, nr1	Recall the decay time associated with the specified AGC mode. Range: 1 - 3 AGD 1, 2000 AGD 2, 20 AGD 3, 200 Example: AGD 1, 2500 AGD 2, 20 AGD 3, 250
AGT nrf		Select AGC threshold mode (Refer to paragraph 4.4.3.1.). Range: 0 - 1 Where: 0 - Off 1 - On
AGT?	AGT nr1	Request active gain control mode. Reset: AGT 0 Default: AGT 0 Example: AGT 1

Table 4-1. Receiver Device Messages (Continued)

Command	Response	Description
BFO nrf		Set frequency in Hz (10 Hz steps). Range: -8000 to +8000 Where: +0000 = BFO Off
BFO?	BFO nr1	Request current BFO frequency. Reset: BFO +0000 Default: BFO +1000 Example: BFO -7990
BIK nrf		Select blanking setting. Range: 0 to 10
BIK?	BIK nr1	Request active blanking setting. Example: BIK 5 Default: BIK 0
BW C nrf		Select an IF bandwidth size in Hz. Range: 0 to 16000 Note: If the value entered is not a standard IF bandwidth (see Table 1-1), the standard IF bandwidth that is greater in value and closest to the requested IF bandwidth will be selected.
BW C?	BW C nr1	Request the current IF bandwidth in Hz. Reset: 06000 Default: 06000 Example: 03200

Table 4-1. Receiver Device Messages (Continued)

Command	Response	Description																																																																		
BW N nrf		<p>Select one of the 66 available IF bandwidth filters. W here nrf represents the filter number. The narrowest bandwidth (.056 kHz) being number 1 and the widest bandwidth (16.0 kHz) being number 66.</p> <p>Range: 001 to 066</p> <p>W here:</p> <table> <tr><td>001 = .056 kHz</td><td>034 = 1.00 kHz</td></tr> <tr><td>002 = .063 kHz</td><td>035 = 1.10 kHz</td></tr> <tr><td>003 = .069 kHz</td><td>036 = 1.20 kHz</td></tr> <tr><td>004 = .075 kHz</td><td>037 = 1.30 kHz</td></tr> <tr><td>005 = .081 kHz</td><td>038 = 1.40 kHz</td></tr> <tr><td>006 = .088 kHz</td><td>039 = 1.50 kHz</td></tr> <tr><td>007 = .094 kHz</td><td>040 = 1.60 kHz</td></tr> <tr><td>008 = .100 kHz</td><td>041 = 1.80 kHz</td></tr> <tr><td>009 = .113 kHz</td><td>042 = 2.00 kHz</td></tr> <tr><td>010 = .125 kHz</td><td>043 = 2.20 kHz</td></tr> <tr><td>011 = .138 kHz</td><td>044 = 2.40 kHz</td></tr> <tr><td>012 = .150 kHz</td><td>045 = 2.60 kHz</td></tr> <tr><td>013 = .163 kHz</td><td>046 = 2.80 kHz</td></tr> <tr><td>014 = .175 kHz</td><td>047 = 3.00 kHz</td></tr> <tr><td>015 = .188 kHz</td><td>048 = 3.20 kHz</td></tr> <tr><td>016 = .200 kHz</td><td>049 = 3.60 kHz</td></tr> <tr><td>017 = .225 kHz</td><td>050 = 4.00 kHz</td></tr> <tr><td>018 = .250 kHz</td><td>051 = 4.40 kHz</td></tr> <tr><td>019 = .275 kHz</td><td>052 = 4.80 kHz</td></tr> <tr><td>020 = .300 kHz</td><td>053 = 5.20 kHz</td></tr> <tr><td>021 = .325 kHz</td><td>054 = 5.60 kHz</td></tr> <tr><td>022 = .350 kHz</td><td>055 = 6.00 kHz</td></tr> <tr><td>023 = .375 kHz</td><td>056 = 6.40 kHz</td></tr> <tr><td>024 = .400 kHz</td><td>057 = 7.20 kHz</td></tr> <tr><td>025 = .450 kHz</td><td>058 = 8.00 kHz</td></tr> <tr><td>026 = .500 kHz</td><td>059 = 8.80 kHz</td></tr> <tr><td>027 = .550 kHz</td><td>060 = 9.60 kHz</td></tr> <tr><td>028 = .600 kHz</td><td>061 = 10.4 kHz</td></tr> <tr><td>029 = .650 kHz</td><td>062 = 11.2 kHz</td></tr> <tr><td>030 = .700 kHz</td><td>063 = 12.0 kHz</td></tr> <tr><td>031 = .750 kHz</td><td>064 = 12.8 kHz</td></tr> <tr><td>032 = .800 kHz</td><td>065 = 14.4 kHz</td></tr> <tr><td>033 = .900 kHz</td><td>066 = 16.0 kHz</td></tr> </table>	001 = .056 kHz	034 = 1.00 kHz	002 = .063 kHz	035 = 1.10 kHz	003 = .069 kHz	036 = 1.20 kHz	004 = .075 kHz	037 = 1.30 kHz	005 = .081 kHz	038 = 1.40 kHz	006 = .088 kHz	039 = 1.50 kHz	007 = .094 kHz	040 = 1.60 kHz	008 = .100 kHz	041 = 1.80 kHz	009 = .113 kHz	042 = 2.00 kHz	010 = .125 kHz	043 = 2.20 kHz	011 = .138 kHz	044 = 2.40 kHz	012 = .150 kHz	045 = 2.60 kHz	013 = .163 kHz	046 = 2.80 kHz	014 = .175 kHz	047 = 3.00 kHz	015 = .188 kHz	048 = 3.20 kHz	016 = .200 kHz	049 = 3.60 kHz	017 = .225 kHz	050 = 4.00 kHz	018 = .250 kHz	051 = 4.40 kHz	019 = .275 kHz	052 = 4.80 kHz	020 = .300 kHz	053 = 5.20 kHz	021 = .325 kHz	054 = 5.60 kHz	022 = .350 kHz	055 = 6.00 kHz	023 = .375 kHz	056 = 6.40 kHz	024 = .400 kHz	057 = 7.20 kHz	025 = .450 kHz	058 = 8.00 kHz	026 = .500 kHz	059 = 8.80 kHz	027 = .550 kHz	060 = 9.60 kHz	028 = .600 kHz	061 = 10.4 kHz	029 = .650 kHz	062 = 11.2 kHz	030 = .700 kHz	063 = 12.0 kHz	031 = .750 kHz	064 = 12.8 kHz	032 = .800 kHz	065 = 14.4 kHz	033 = .900 kHz	066 = 16.0 kHz
001 = .056 kHz	034 = 1.00 kHz																																																																			
002 = .063 kHz	035 = 1.10 kHz																																																																			
003 = .069 kHz	036 = 1.20 kHz																																																																			
004 = .075 kHz	037 = 1.30 kHz																																																																			
005 = .081 kHz	038 = 1.40 kHz																																																																			
006 = .088 kHz	039 = 1.50 kHz																																																																			
007 = .094 kHz	040 = 1.60 kHz																																																																			
008 = .100 kHz	041 = 1.80 kHz																																																																			
009 = .113 kHz	042 = 2.00 kHz																																																																			
010 = .125 kHz	043 = 2.20 kHz																																																																			
011 = .138 kHz	044 = 2.40 kHz																																																																			
012 = .150 kHz	045 = 2.60 kHz																																																																			
013 = .163 kHz	046 = 2.80 kHz																																																																			
014 = .175 kHz	047 = 3.00 kHz																																																																			
015 = .188 kHz	048 = 3.20 kHz																																																																			
016 = .200 kHz	049 = 3.60 kHz																																																																			
017 = .225 kHz	050 = 4.00 kHz																																																																			
018 = .250 kHz	051 = 4.40 kHz																																																																			
019 = .275 kHz	052 = 4.80 kHz																																																																			
020 = .300 kHz	053 = 5.20 kHz																																																																			
021 = .325 kHz	054 = 5.60 kHz																																																																			
022 = .350 kHz	055 = 6.00 kHz																																																																			
023 = .375 kHz	056 = 6.40 kHz																																																																			
024 = .400 kHz	057 = 7.20 kHz																																																																			
025 = .450 kHz	058 = 8.00 kHz																																																																			
026 = .500 kHz	059 = 8.80 kHz																																																																			
027 = .550 kHz	060 = 9.60 kHz																																																																			
028 = .600 kHz	061 = 10.4 kHz																																																																			
029 = .650 kHz	062 = 11.2 kHz																																																																			
030 = .700 kHz	063 = 12.0 kHz																																																																			
031 = .750 kHz	064 = 12.8 kHz																																																																			
032 = .800 kHz	065 = 14.4 kHz																																																																			
033 = .900 kHz	066 = 16.0 kHz																																																																			
BW N?	BW N nrl	<p>Request active IF bandwidth number.</p> <p>Reset: BW N 055</p> <p>Default: BW N 055</p> <p>Example: BW N 028</p>																																																																		

Table 4-1. Receiver Device Messages (Continued)

Command	Response	Description
BW S nrf	BW S nr1	Select an IF bandwidth. Range: 1-5 Where: 1 - 0.30 kHz 2 - 1.00 kHz 3 - 3.20 kHz 4 - 6.00 kHz 5 - 16.0 kHz
BW S?	BW S nr1	Request the active IF bandwidth slot. Reset: BW S 4 Default: BW S 4 Example: BW S 1
CHA nrf		Select start channel for channel scan. Range: 00 to 98
CHA?	CHA nr1	Request currently selected channel for channel scan. Example: CHA 25 Default: CHA 0
CHB nrf		Select stop channel for channel scan. Range: 01 to 99
CHB?	CHB nr1	Request currently selected stop channel for channel scan. Example: CHB 26 Default: CHB 99
CHI nrf		Include channel when in channel scan. Range: 0 to 99
CHS nrf		Skip channel when in channel scan. Range: 0 to 99
CIM		Clear all memories.
CTLnrf		Set the device control mode. Range: 0 - 2 Where: 0 - Local 1 - Remote 2 - Remote w/ Local Lockout
CTL?	CTLnr1	Request the device control mode. Default: CTL0 Example: CTL1

Table 4-1. Receiver Device Messages (Continued)

Command	Response	Description
DET nrf		Set the detection mode. Range: 1 - 7 Where: 1 - AM 2 - FM 3 - CW 4 - USB 5 - LSB 6 - ISB 7 - SAM
DET?	DET nr1	Request the active detection mode. Reset: DET 1 Default: DET 1 Example: DET 4
ENA		Continue suspended scan command.
EXE nrf		Recall and execute specified memory channel. Range: 0 to 99
FRA nrf		Select start frequency for Frequency-to-Frequency (F1-to-F2) scan in MHz.
FRA?	FRA nr2	Range: 0.000000 to 29.999999 Request current Frequency-to-Frequency (F1-to-F2) scan start frequency in MHz. Example: FRA 23.123456 Default: FRA 00.000000
FRB nrf		Select stop frequency for Frequency-to-Frequency (F1-to-F2) scan in MHz. Range: 0.000001 to 30.000000
FRB?	FRB nr2	Request current Frequency-to-Frequency (F1-to-F2) scan stop frequency in MHz. Example: FRB 27.123456 Default: FRB 30.000000

Table 4-1. Receiver Device Messages (Continued)

Command	Response	Description									
FRQ nrf		Set the tuned frequency in MHz (1-Hz steps). Range: 00.000000 to 30.000000									
FRQ?	FRQ nr1	Request the tuned frequency. Reset: FRQ 20.000000 Default: FRQ 20.000000 Example: FRQ 12.345678									
INC nrf		Select Frequency-to-Frequency (F1-to-F2) scan increment in kHz. Range: 0.001 to 25.000									
INC?	INC nr2	Request current Frequency-to-Frequency (F1-to-F2) scan increment in kHz. Example: INC 20.000 Default: INC 25.000									
ICK nrf nrf		Enter a lockout to be used in the (F1-to-F2) scan w/ Lock mode. The lockout is specified as a center frequency only. The lockout width is \pm half of the current IF bandwidth selection. Once stored, the lockout width remains the same, regardless of future IF bandwidth changes. The channel number assigned with this command remains constant as channels are added or deleted. This lockout data overwrites any data previously stored in the selected lockout channel.									
		<table border="0"> <thead> <tr> <th><u>Field</u></th> <th><u>Parameter</u></th> <th><u>Range</u></th> </tr> </thead> <tbody> <tr> <td>1</td> <td>Channel number</td> <td>0 to 99</td> </tr> <tr> <td>2</td> <td>Lockout center frequency</td> <td>0.000000 to 30.000000</td> </tr> </tbody> </table>	<u>Field</u>	<u>Parameter</u>	<u>Range</u>	1	Channel number	0 to 99	2	Lockout center frequency	0.000000 to 30.000000
<u>Field</u>	<u>Parameter</u>	<u>Range</u>									
1	Channel number	0 to 99									
2	Lockout center frequency	0.000000 to 30.000000									
MUT?	MUT nr1	Request the current mute status. Range: 0,1 Where: 0 = Audio not muted 1 = Audio muted									

Table 4-1. Receiver Device Messages (Continued)

Command	Response	Description
NFM nrf		Set the tunable notch filter mode. Range: 0,1 Where: 0 = OFF 1 = Relative (ON)
NFM?	NFM nrl	Request the current tunable notch filter mode. Range: 0 to 3 Where: 0 = OFF 1 = Relative (ON) 2 = Not Used 3 = Disabled Note: A disabled response occurs when the notch filter relative setting is outside the specified limits of the selected bandwidth. Refer to paragraph 3.5.10 .
NFR nrf		Set the tunable notch filter setting. Refer to paragraph 3.5.10 for a list of the maximum relative settings for each bandwidth. Range: -9999 to +9999 Hz
NFR?	NFR nrl	Request the current tunable notch filter setting. Reset: 0000 Default: 0000 Example: -6200

Table 4-1. Receiver Device Messages (Continued)

Command	Response	Description																																	
O PR nrf		Select operation mode. Range: 0, 1 Where: 0 = Manual 1 = scan (type of scan is dependent on current scan type (SCF) selection.)																																	
O PR?	O PR nr1	Request current operation mode. Example: O PR 1 Default: O PR 0 Reset: O PR 0 Default: O PR 0																																	
PBT nrf		Selected passband tuning offset frequency. Only effective in CW detection mode. Range: -2000 to +2000 Hz (10 Hz steps)																																	
PBT?	PBT nr1	Request current passband tuning offset frequency in Hz. Example: PBT 1250 Reset: PBT 0 Default: PBT 0																																	
RCL? nrf	RCLnr1,nr1, nr2,nr1,nr1,nr1, nr1,nr1	Recall selected memory channel parameters. Range: 0 to 99																																	
	<table border="1"> <thead> <tr> <th>Field</th> <th>Parameter</th> <th>Range</th> </tr> </thead> <tbody> <tr> <td>1</td> <td>Memory channel number</td> <td>0 to 99</td> </tr> <tr> <td>2</td> <td>Skip/ include channel</td> <td>0 = skip, 1 = include</td> </tr> <tr> <td>3</td> <td>Tuned frequency (FQR)</td> <td>0.000000 to 30.000000 MHz</td> </tr> <tr> <td>4</td> <td>AGC mode (AGC)</td> <td>0 to 3</td> </tr> <tr> <td>5</td> <td>Detection mode (DET)</td> <td>1 to 7</td> </tr> <tr> <td>6</td> <td>Bandwidth number (BWN)</td> <td>001 to 066 (see BWN command)</td> </tr> <tr> <td>7</td> <td>Squelch threshold (SQL)</td> <td>0 to 135 -dBm, 136 = no squelch</td> </tr> <tr> <td>8</td> <td>RF input (RFP)</td> <td>1 to 3</td> </tr> <tr> <td>9</td> <td>BFO Frequency (BFO)</td> <td>-8000 to +8000 Hz</td> </tr> <tr> <td>10</td> <td>Remote Manual Gain Level (RFG)</td> <td>000 - 127</td> </tr> </tbody> </table>	Field	Parameter	Range	1	Memory channel number	0 to 99	2	Skip/ include channel	0 = skip, 1 = include	3	Tuned frequency (FQR)	0.000000 to 30.000000 MHz	4	AGC mode (AGC)	0 to 3	5	Detection mode (DET)	1 to 7	6	Bandwidth number (BWN)	001 to 066 (see BWN command)	7	Squelch threshold (SQL)	0 to 135 -dBm, 136 = no squelch	8	RF input (RFP)	1 to 3	9	BFO Frequency (BFO)	-8000 to +8000 Hz	10	Remote Manual Gain Level (RFG)	000 - 127	
Field	Parameter	Range																																	
1	Memory channel number	0 to 99																																	
2	Skip/ include channel	0 = skip, 1 = include																																	
3	Tuned frequency (FQR)	0.000000 to 30.000000 MHz																																	
4	AGC mode (AGC)	0 to 3																																	
5	Detection mode (DET)	1 to 7																																	
6	Bandwidth number (BWN)	001 to 066 (see BWN command)																																	
7	Squelch threshold (SQL)	0 to 135 -dBm, 136 = no squelch																																	
8	RF input (RFP)	1 to 3																																	
9	BFO Frequency (BFO)	-8000 to +8000 Hz																																	
10	Remote Manual Gain Level (RFG)	000 - 127																																	

Table 4-1. Receiver Device Messages (Continued)

Command	Response	Description
REF?	REF nr1	Request the status of the external reference. Range: 0 - 4 Where: 0 - Internal 1 - 10 MHz External 2 - 5 MHz External 3 - 2 MHz External 4 - 1 MHz External Example: REF 3
RFG nrf		Set the remote manual gain level. Range: 000 -127
RFG?	RFG nr1	Request the remote manual gain level. Reset: RFG 000 Default: RFG 000 Example: RFG 123
RFP nrf		Select the RF input path. Range: 1 - 3 Where: 1 - Normal 2 - Attenuated 3 - Preamplified
RFP?	RFP nr1	Request the selected RF input path. Reset: RFP 1 Default: RFP 1 Example: RFP 2
RLK? nrf	RLK nr1 ,nr2	Recall the selected lockout channel center frequency. When the lockout memory channel is vacant a frequency of 31.000000 MHz is returned. Range: 0 to 99 Example: 12, 27.123456
SCF nrf		Select desired scan type. Range: 1 to 3 Where: 1 = Channel scan 2 = F1 to F2 3 = F1 to F2 w/ Lock
SCF?	SCF nr1	Request the currently selected scan type. Example: SCF 1 Default: SCF 2

Table 4-1. Receiver Device Messages (Continued)

Command	Response	Description
SCS?	SCS nr1	Request the current receiver scan status. Range: 0 to 3 Where: 0 = No scan 1 = Scan 2 = Scan dwell 3 = Scan paused
SDW nrf		Select the scan dwell time. Range: 0.5 to 20 seconds, 0 = infinite
SDW ?	SDW nr1	Request currently selected scan dwell time. Example: SDW 2 Default: SDW 0.5
SGV?	SGV nr1,nr1	Request the signal strength value (in dBm) and squelch status value. Range: +20 to -135,0-1 Where: nr1,0 - squelch on nr1,1 - squelch off Reset: No Change Example: SGV -123,0
SIM?	SIM nr1	Request number of unused lockout channels available. Range: 0 to 100 Example: SIM 75 Reset: SIM 100
SPK nrf		Select speaker type. Range: 1 to 3 Where: 1 = USB 2 = Both 3 = LSB
SPK?	SPK nr1	Request currently selected speaker type. Example: SPK 2 Default: SPK 2

Table 4-1. Receiver Device Messages (Continued)

Command	Response	Description
SQ Lnr1		Set squelch level in negative dBm. Range: 0 to 135, 136 = squelch off
SQ I?	SQ Lnr1	Request the squelch level setting in -dBm (136 = squelch off). Example: SQ L90 Reset: SQ L136
STO nrf	O PR nr1	Store front panel parameters to selected memory channel. Range: 0 to 99
STS?		Request current receiver parameters. Example: FRQ 12.34567,AGC 2,RFG 123,BFO -1234, BLK 10,BW S 5,DET 1,SQ 123,SPK 1, RFP 2,PBT 1250
<u>Field</u>	<u>Parameter</u>	<u>Range</u>
1	Tuned Frequency (FRQ)	00.000000 to 30.000000 MHz
2	Detection Mode (DET)	1 to 6
3	Bandwidth Number (BW N)	001 to 066 (see BW N command)
4	AGC Mode (AGC)	0 to 3
5	Remote Manual Gain Level (RFG)	000 - 127
6	BFO Frequency in kHz (BFO)	-8000 to +8000 Hz
7	Blanking Setting (BLK)	0 to 10
8	Squelch Threshold (SQ L)	0 to 135 -dBm 136 = no squelch
9	Speaker Type (SPK)	1 to 3
10	RF Input Path (RFP)	1 to 3
11	Passband Tuning Offset (PBT)	-2000 to +2000 Hz
12	Notch Filter Mode (NFM)	0 to 3
13	Notch Filter Setting (NFR)	-9999 to +9999 Hz
SUS		Suspend scan command. Suspends scan in the same manner as the front panel "pause" key pauses scan. Scan may be continued using the ENA command.
UIK nrf		Unlock selected lockout memory channel. Range: 0 to 99

4.5 COMMUNICATION MESSAGES

Communication messages are always valid. These are commands which establish communications between the WJ8711A and the controller. All WJ8711A communication messages are listed in **Table 4-2**. Common communication messages are prefixed with an asterisk.

Table 4-2. Communication Messages

Command	Response	Description
CDE?	CDE nr1	Request the current Device-Dependent Error Register value. Example: CDE 00255 Range: 00000 - 65535 See Table 4-6 for bit-mapped detail.
* CIS		Clears all communication status registers.
* ESE nrf		Set the Event Summary Enable Register. See discussion of the Event Summary Registers for bit-mapped details. Range: 0 - 255
* ESE?	* ESE nr1	Request the Event Summary Enable Register value. Reset: No change Default: * ESE 000 Example: * ESE 128
* ESR?	* ESR nr1	Request the Event Summary Status Register value. See Table 4-4 for bitmapped details. Example: * ESR 016 Range: 0 - 255 Bit 0 - OPC Operation Complete Bit 1 - Not Used Bit 2 - QYE Query Error Bit 3 - DDE Device-Dependent Error Bit 4 - EXE Execution Error Bit 5 - CME Command Error Bit 6 - Not Used Bit 7 - PON Power On
* IDN?	* IDN (see example)	Request receiver identity. The fields provide information in the following order: model number, space reserved for future expansion, and software version number. Example: * IDN WJ8711,0,1.40
IDE?	IDE nr1	Request the latched Device-Dependent Error Register value. Example: IDE 00255 Range: 00000 - 65535 See Table 4-6 for bit-mapped detail.

Table 4-2. Communication Messages (Continued)

Command	Response	Description																														
*IRN?	*IRN nr2,nr1, nr1,nr1,nr1,nr1, nr1,nr1,	Request current WJ8711A operating parameters. The data returned for this query is field dependent.																														
		<table border="1"> <thead> <tr> <th>Field</th> <th>Parameter</th> <th>Range</th> </tr> </thead> <tbody> <tr> <td>1</td> <td>Tuned Frequency (FRQ)</td> <td>00.000000 to 30.000000 MHz</td> </tr> <tr> <td>2</td> <td>AGC Mode (AGC)</td> <td>0 to 2</td> </tr> <tr> <td>3</td> <td>Detection Mode (DET)</td> <td>1 to 6</td> </tr> <tr> <td>4</td> <td>Bandwidth number (BWN)</td> <td>001 to 066 (see BWN command)</td> </tr> <tr> <td>5</td> <td>Squelch threshold (SQL)</td> <td>0 to 135 -dBm, 136 = no squelch</td> </tr> <tr> <td>6</td> <td>RF input (RFP)</td> <td>1 to 3</td> </tr> <tr> <td>7</td> <td>BFO frequency (BFO)</td> <td>-8000 to +8000 Hz (in 10 Hz steps)</td> </tr> <tr> <td>8</td> <td>Blanking (BLK)</td> <td>0 to 10</td> </tr> <tr> <td>9</td> <td>Speaker (SPK)</td> <td>1 to 3</td> </tr> </tbody> </table>	Field	Parameter	Range	1	Tuned Frequency (FRQ)	00.000000 to 30.000000 MHz	2	AGC Mode (AGC)	0 to 2	3	Detection Mode (DET)	1 to 6	4	Bandwidth number (BWN)	001 to 066 (see BWN command)	5	Squelch threshold (SQL)	0 to 135 -dBm, 136 = no squelch	6	RF input (RFP)	1 to 3	7	BFO frequency (BFO)	-8000 to +8000 Hz (in 10 Hz steps)	8	Blanking (BLK)	0 to 10	9	Speaker (SPK)	1 to 3
Field	Parameter	Range																														
1	Tuned Frequency (FRQ)	00.000000 to 30.000000 MHz																														
2	AGC Mode (AGC)	0 to 2																														
3	Detection Mode (DET)	1 to 6																														
4	Bandwidth number (BWN)	001 to 066 (see BWN command)																														
5	Squelch threshold (SQL)	0 to 135 -dBm, 136 = no squelch																														
6	RF input (RFP)	1 to 3																														
7	BFO frequency (BFO)	-8000 to +8000 Hz (in 10 Hz steps)																														
8	Blanking (BLK)	0 to 10																														
9	Speaker (SPK)	1 to 3																														
*OPC		Operation complete switch. When this command is sent with a data string, the OPC bit in the Event Summary Status Register will be set upon completion of the operation(s) in the input buffer. An SRQ may be generated with corresponding bit enabled.																														
*OPC?	*OPC 1	An *OPC 1 string will be loaded into the output buffer (returned at the completion of the operation in the input buffer).																														
*OPT?	*OPT nr1,nr1	Request the options currently installed in the receiver. The returned response is a bit-mapped value of two 8 bit bytes. Range: 0 -255, 0 -255 Example: *OPT016 1st nr1 bit-mapped response: Bit 0 - Preselector Option Bit 1 - Extended Bandwidths Bit 2 - Tuned Carrier Bit 3 - Variable Line Audio Bit 4 - Tunable Notch Filter Bit 5 - AGC/ Detection Mode Matching Bit 6 - Zero Digit tuning Bit 7 - Synchronous AM 2nd nr1 bit-mapped response: Bit 0 - AGC Enhancements Bit 1 - Speech Enhancement Bit 2 to Reserved for future expansion Bit 7																														

Table 4-2. Communication Messages (Continued)

Command	Response	Description
*RSE nrf		<p>This command allows writing to a register that enables interrupts to be passed from the RSR register to the *STB register via its RSB bit.</p> <p>BIT FUNCTION</p> <p>0 Enable PRS, signal exceeded COR event to set the RSB bit.</p> <p>1-3 Not Used</p> <p>4 Enable ESN, end of single scan event to set the RSB bit.</p> <p>5-7 Not used.</p>
*RSE?	*RSE nr1	<p>Request the contents of the Receiver Status Enable Register.</p> <p>Reset: no change Default: *RSE 000 Example: *RSE 016</p>
*RSR?	*RSR nr1	<p>Read the Receiver Status Register. The information included in this register is latched. It is cleared by the *CLS command or a read of the register. The information in the register discloses the reason for the RSB bit to be set in the Status Byte Register.</p> <p>BIT FUNCTION</p> <p>0 PRS, signal exceeded COR threshold. This is an edge triggered event on the action of a signal going from below COR threshold to above COR threshold.</p> <p>1-3 Not used.</p> <p>4 ESN, end of single scan. This bit indicates the end of scan has been encountered. This bit is only set while in a scan mode. (F1 → F2, F1 → F2 w/ Lock, Channel)</p> <p>5-7 Not used</p>
*RST		For all device parameters to their reset condition.

Table 4-2. Communication Messages (Continued)

Command	Response	Description
*SRE nrf		Set the Service Request Enable Register. See discussion of the Status Byte Registers for bit-mapped details. Range: 0 - 255
*SRE?	*SRE nr1	Request the Service Request Enable Register value. Reset: No Change Default: *SRE 000 Example: *SRE 032
*STB?	*STB nr1	Request the Status Byte Register value. See Table 4-3 for bit-mapped details. Range: 0 - 255 Example: *STB 064 Bit 0 - RSB Bit 1 - Not Used Bit 2 - Not Used Bit 3 - Not Used Bit 4 - Not Used Bit 5 - ESB Event Summary Bit Bit 6 - RQ S Request Service Bit 7 - Not Used
*TST?	*TST nr1	Execute built-in-test (BIIE) and report outcome. The response is a bit-mapped value of 16 bits, representing the success or failure of each test. Any failed test will set the associated bit as listed below. Range: 0 - 65535 Example: *TST 00000 Bit Failure 0 Control to DSP transmit pipeline not empty. 1 Control to DSP download unsuccessful. 2 DSP EPROM download unsuccessful. 3 Control command not acknowledged. 4 No DSP response to control request. 5 DSP memory check did not complete. 6 DSP EPROM failure. 7 DSP SRAM failure. 8 RF test failed. 9 Control A/D failure. 10 Non-SSB audio failure. 11 USB audio failure. 12 USB audio in ISB path failure. 13 ISB audio failure. 14 ISB audio in USB path failure. 15 DSP A/D failure.

4.6 RECEIVER STATUS SUMMARY

Figure 4-1 illustrates the architecture of the receiver's status registers. It is composed of six eight-bit registers and one 16-bit register, whose logic gating allows the programmer great flexibility in remote operations. The eight bit registers can be split into three pairs. Each pair consists of a status register and an enable register.

One pair is composed of the Event Summary Status Register (whose functions are summarized in **paragraph 4.6.2**) and the Event Summary Status Enable Register. Each bit in the Event Summary Status Register is logically ANDed to a bit in the Event Summary Status Enable Register. The ANDed combination of these two registers are logically ORed to set the Event Summary Status Bit (ESB) of the Status Byte Register. The Device-Dependent Error Bit (DDE) of the Event Summary Status Register is the ORed combination of the 16-bit Device-Dependent Error Register (see **paragraph 4.6.4**).

The second pair is composed of the Status Byte Register and the Service Request Enable Register. The receiver uses only three bits of the Status Byte Register as described in **Table 4-3**. The ANDed combination of bits 0 and 5 of the Status Byte Register and the Service Request Enable Register are logically ORed to determine the setting of bit six (RQS) of the Status Byte Register. If the RQS bit is set high, a service request is asserted.

Table 4-3. Status Byte Register, Bit Evaluation

Bit Number	Mnemonic	Description
0	RSB	Receiver Status Bit - This bit, when set, indicates that an event has caused a bit or bits in the Receiver Status Register to be set (see paragraph 4.6.3). This bit is cleared by *CIS or by reading the contents of the Receiver Status Register using the RSR? query.
1-4	Not Used	
5	ESB	Event Summary Bit - This bit, when set, indicates that the Event Summary Status Register has set SRQ. By reading the Event Summary Status Register via the *ESR? mnemonic, the host controller may identify what status event has caused the SRQ. This bit is cleared by sending, *CIS or reading the contents of the Event Status Register.
6	RQS	Request Service Bit - This bit, when set, indicates that the unit has asserted SRQ.
7	Not Used	

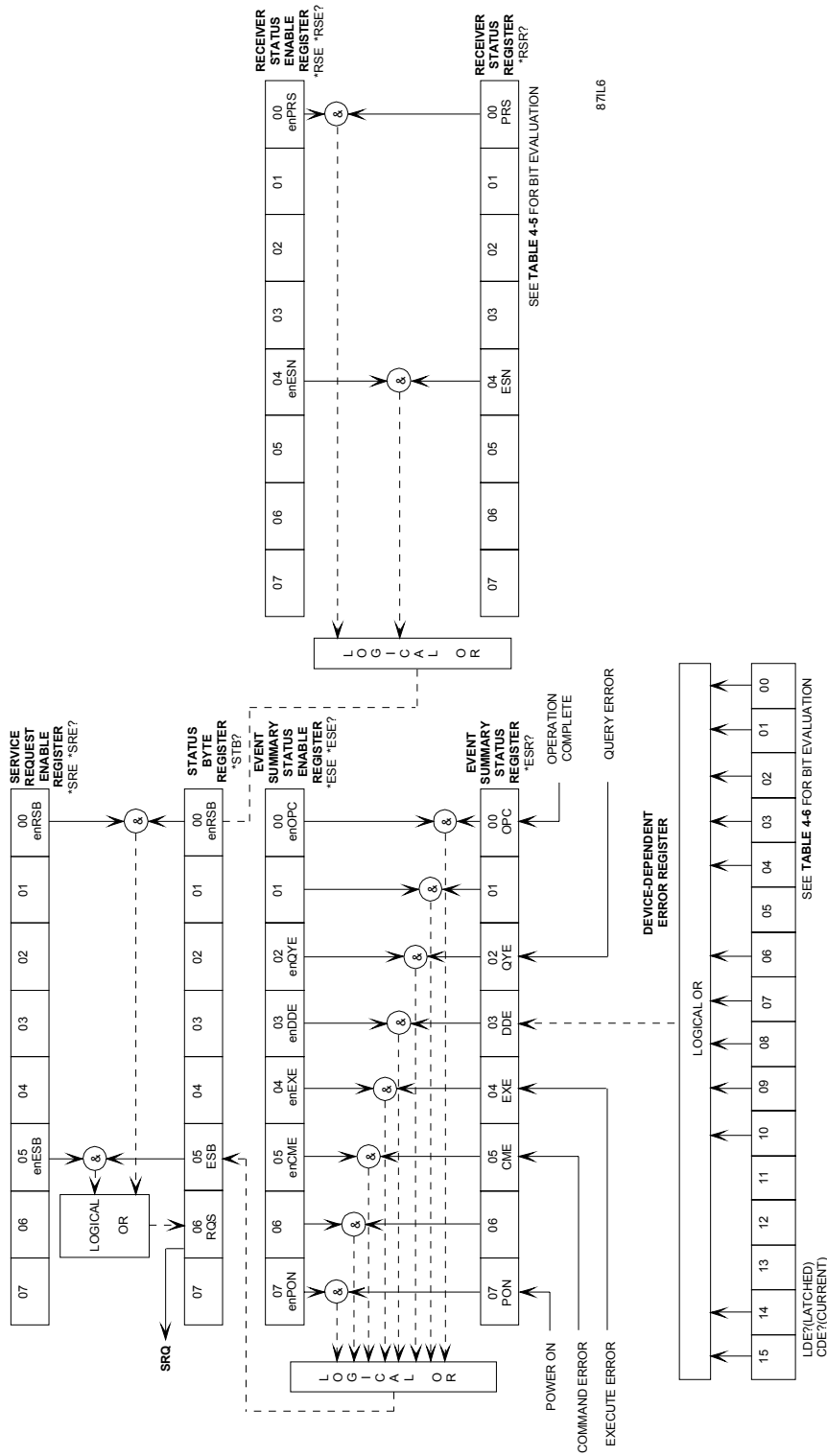

Figure 4-1. Receiver Status Data Structure

4.6.1 STATUS BYTES

The following information discusses the operation of the SRQ interrupt and the "*STB?" query. The operation of these is very similar. The SRQ interrupt allows the controller to establish which event has caused the receiver to set the SRQ. The "*STB?" query response includes similar information as detailed below.

SRQ - This is a one byte control character (ESC) indicating a service request. When SRQ is generated, it is immediately followed by the output of the Status Byte Register if enabled. This clears the SRQ and the Status Byte Register. The evaluation of each bit in this status byte is in **Table 4-3**.

***STB? Query** - The Status Byte Register can also be read using the *STB? query. Sending *STB? does not clear the SRQ status line or the Status Byte Register.

The Service Request Enable Register allows status bits to generate service requests. Setting a status bit will set service request if and only if the corresponding enable bit is set. Service Request Enable Register bit six is ignored and reported as zero. This bit would correspond to the RQS bit of the Status Byte Register which triggers service request.

4.6.2 EVENT SUMMARY STATUS REGISTER

The following discussion covers the Event Summary Status Register and the *ESR? query. See **Table 4-4** for the Event Summary Status Register bit numbers, mnemonics and descriptions.

The Event Summary Status Register is read destructively by the *ESR? query, which clears the register. The *CIS command also clears the register. The power on sequence automatically sets the Power On bit and initially resets the remaining bits.

The Event Summary Status Enable Register allows the event flags of the Event Summary Status Register to be reflected in the Event Summary Bit (ESB) of the Status Byte. The setting of an event status flag sets ESB high only if the corresponding bit in the Event Summary Status Enable Register is set high. The Event Summary Status Enable Register is written to with the *ESE command. The data following the mnemonic is the decimal equivalent of a binary number representing the register bits. The *ESE? query loads the output buffer with a decimal number, which can be converted to binary to determine the setting of the Event Summary Status Enable Register.

Table 4-4. Event Summary Status Register, Bit Evaluation

Bit Number	Mnemonic	Description
0	OPC	Operation Complete - This bit is set on completion of operation that has been designated by the *OPC command.
2	QYE	Query Error - Set on an attempt to read data from the output buffer with no data stored or pending, or the output buffer is dumped for any cause except device clear, such as an overflow.
3	DDE	Device-Dependent Error - Set when a hardware error occurs within the receiver.
4	EXE	Execution Error - Set when an out of range data element follows a known message header or when a valid message count not be executed due to some device condition.
5	CME	Command Error - Set when an unrecognized message header has been received.
7	PON	Power On - Set during the power-up sequence. Also set when a Device or Select Device Clear is received.

4.6.3 RECEIVER STATUS REGISTER

The Receiver Status Register allows for interrupts to be generated when particular operational events occur. The information in this register discloses the reason for the RSB bit to be set in the Status Byte Register. The *RSR? query reads the latched contents of this register and clears it. It is also cleared by *CIS. See **Table 4-5** for the bit evaluation of the Receiver Status Register.

Table 4-5. Receiver Status Register, Bit Evaluation

Bit	Decimal Value	Function
0	1	PRS, signal exceeded COR threshold. This is an edge triggered event on the action of a signal going from below COR threshold to above COR threshold.
1	2	Not used
2	4	Not used
3	8	Not used
4	16	ESN, end of scan. This bit indicates the end of scan has been encountered. This bit is only set while in a scan mode (F1→F2, F1→F2 w/ Lock, or Channel).
5	32	Not used
6	64	Not used
7	128	Not used

4.6.4 DEVICE-DEPENDENT ERROR REGISTER

The contents of the Device-Dependent Error Register can be read to determine what event has caused the DDE bit in the Event Status Register to be set. The CDE? and IDE? queries are used as further discussed below.

The IDE? query request the latched error status. The response is a bit-mapped 16-bit word indicating the error conditions that have occurred since the last read of the register. Reading the contents of the register also clears it. See **Table 4-6** for a bit evaluation of the Device-Dependent Error Register.

The CDE? query request the current device error. The response to this query is also a bit-mapped 16-bit word as detailed in **Table 4-6**. Reading this register has no effect on it.

Table 4-6. Device-Dependent Error Register, Bit Evaluation

Bit	Decimal Value	Mnemonic	Description
0	1	DSP ERR 1	Control to DSP transmit pipeline not empty.
1	2	DSP ERR 2	Control to DSP download unsuccessful.
2	4	DSP ERR 3	DSP EPROM download unsuccessful.
3	8	DSP ERR 4	Control command not acknowledged by DSP.
4	16	DSP ERR 5	No DSP response to Control request.
5	32	Not Used	
6	64	PS ERR 1	-12 Volt Supply Low.
7	128	PS ERR 2	+12 Volt Supply Low.
8	256	BATT ERR	Battery Voltage Low.
9	512	LO ERR	Local Oscillator Unlocked.
10	1024	REF ERR	Unknown External Reference.
11	2048	RAM FAIL	Control Processor RAM Failure.
12	4096	CHKSUM	EPROM Checksum Error.
13	8192	PRESELOVRID	Preselector Overload (when the WJ8711/ PRE option is installed).
14	16384	Not used	
15	32768	Not used	

4.7 MESSAGE PROCESSING

When the WJ8711A receives a remote message, it stores it in an input buffer circuit until it receives a valid message terminator (IF). When the terminator is received, the message is parsed and executed.

The format of the received message is checked for validity as the message is parsed and executed. If the message fails to meet the restrictions of the command message format, it is ignored.

4.8 RS-232 COMMUNICATIONS PROTOCOL

The communications protocol for the WJ8711A implements both ENQ/ACK (ENQUIRE/ACKNOWLEDGE) and XON/XOFF (ctl Q/ctl S) software handshakes. The ENQ/ACK format, typically referred to as "transmitter protocol", allows the operator to send an "ENQ" character to the WJ8711A when an acknowledge is required. The receiver then responds with the ACK/NAK (ACKNOWLEDGE/NOT ACKNOWLEDGE) character indicating the validity of the data received in the input buffer and the fact the unit has completed all current data through to the last received terminator. The XON/XOFF format supports both transmit and receive communications. This format, typically referred to as "receiver protocol", allows transmission based on the availability of buffer space (refer to **paragraph 4.8.3**).

Table 4-7 lists the supported communications control commands for RS-232 remote operation. The following paragraphs provide more details on the ENQ/ACK and XON/XOFF protocol, and buffer control.

Table 4-7. Supported RS-232C Communications Control Commands

HEX	ASCII	Receive	Transmit	Function
11	DC	x	x	XON, allow data transmission
13	DC3	x	x	XOFF, disallow data transmission
05	ENQ	x		Enquire, request acknowledge
06	ACK		x	Acknowledged, data received
15	NAK		x	Not acknowledged, data communications error
0A	IF	x	x	Line feed, start processing input buffer
0D	CR	x	x	Carriage return, no action

4.8.1 XON/XOFF PROTOCOL

The XON/XOFF communications protocol is always active in the WJ8711A. In the event the buffer has room for less than 16 additional characters the unit will output an XOFF character. When the unit empties its input buffer, it issues an XON character. The user must stop sending data within 15 characters after receiving the XOFF character. On each character that is received while the buffer is full, the unit issues an XOFF character. The user may start sending data to the unit after receiving the XON character.

The WJ8711A responds to the XON and XOFF commands while outputting data to the user. If the unit receives an XOFF while sending, it stops transmitting within two characters. The unit will not transmit any further data until an XON is received. The WJ8711A assumes the XON condition at power-up.

4.8.2 ENQ/ ACK PROTOCOL

When the ENQ character is sent to the WJ8711A, it responds to a valid message with an ACK, or to an invalid message with a NAK. An invalid message is indicated on a data communications error such as framing, noise, or overrun. The transmission of a NAK indicates that one or more of the bytes received after the last ENQ has a communications error. The ACK/ NAK response is only sent after the unit has completed processing any previous messages in the input buffer and has output any response necessary. See **Table 4-7**.

WJ8711A internally maintains a communications error flag. The flag is cleared on power-up or the transmission of a NAK. The flag is set when a byte is received with a data communications error. Upon receiving an ENQ character, the unit responds with an ACK/ NAK based on the condition of the communications flag, after any pending input and output operations are complete.

4.8.3 BUFFER HANDLING

INPUT BUFFER

The input buffer is handled in circular fashion allowing simultaneous inputting and processing of data. The input buffer accepts up to 1024 bytes before overflowing. As data in the buffer is being processed, additional inputs can be accepted by the unit. Upon receiving a terminator character, the WJ8711A processes any previous messages in the buffer. When the buffer has less than 16 unused bytes, XOFF is generated. XON is generated when the buffer has less than 16 bytes remaining to be processed.

The input buffer processing starts on the receipt of a terminator (LF). If the communications error flag is set, the buffer contents from the end of the last processed message thru the message terminator is discarded. In the event the buffer is overrun, its contents are discarded. Messages such as XON, XOFF, and ENQ have immediate actions. These commands are processed on receipt and are not buffered. All other incoming data is buffered and processed in the order in which it was received.

OUTPUT BUFFER

The output buffer is handled in circular fashion allowing simultaneous additions and outputting. The transmission of XON/ XOFF has priority over data in the output buffer that is awaiting transmission. The ACK/ NAK transmission are buffered operations so they stay in time synchronization with query operations. The output buffer holds up to 1024 bytes of data.

NOTES

SECTION 5

CSMA REMOTE CONTROL

THIS PAGE INTENTIONALLY LEFT BLANK

SECTION 5

CSMA REMOTE CONTROL

5.1 INTRODUCTION

This section provides information for controlling the WJ8711A Digital HF Receiver via a CSMA/CD interface. The Carrier Sense Multiple Access with Collision Detection interface (hereafter referred to as a CSMA interface) is a media access method that allows up to 63 devices to be addressed on a common bus interface. To transmit, a controller waits for a quiet period on the medium (that is, no other device is transmitting) and then sends a message in byte-serial form. The controller waits for responses to queries or for Acknowledge (ACK) or Not Acknowledge (NAK) messages before proceeding with the next command or query. Message collisions can occur on a CSMA interface and are more likely when the system hardware limitations are pushed beyond recommendations. The CSMA interface detects these collisions and tries to overcome resulting communications loss. See paragraph 5.9 for a full description of the behavior of the interface during collision detection.

5.2 CONTROLLING MULTIPLE RECEIVERS VIA THE CSMA INTERFACE

System hardware configuration will dictate the limitations regarding the number of units physically capable of being controlled. For best results, DRS Signal Solutions, Inc. recommends the following:

Limit the number of bus controllers to one;

Send one command line at a time;

Wait for a response to a query or an Acknowledgment (ACK) or non-Acknowledgment (NAK) of a command before proceeding with the next step;

Do not string commands and queries together on a single command line;

Avoid commands that do not task the receiver to return an ACK/NAK or other response;

Limit the number of devices on the bus;

DRS Signal Solutions, Inc. recommends the use of a ICOM CT-17 CIV Level Converter to control multiple receivers via their CSMA interfaces when the controller is a PC equipped with an RS-232 serial interface. Refer to **Figure 5-1**. DRS Signal Solutions, Inc. has successfully driven up to six receivers by adding audio adapter jacks to extend the four outputs provided by the ICOM CT-17.

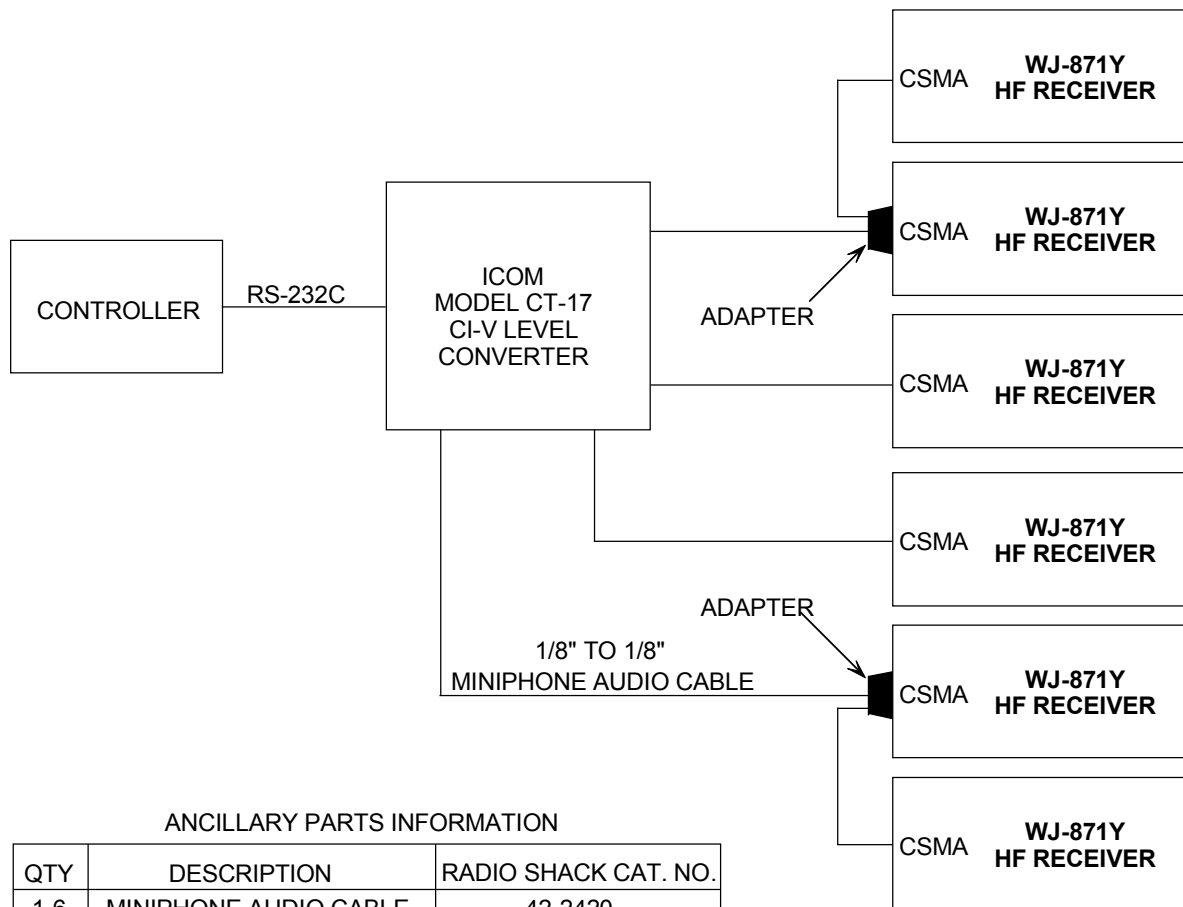

ANCILLARY PARTS INFORMATION

QTY	DESCRIPTION	RADIO SHACK CAT. NO.
1-6	MINIPHONE AUDIO CABLE (1/8" TO 1/8")	42-2420
0-2	DUAL MINIPHONE ADAPTER	274-310

95-1188

Figure 5-1. Recommended Controller Setup

5.3 SETTING UP THE RECEIVER FOR REMOTE CSMA INTERFACE

The WJ8711A can be set for CSMA remote control by selecting "CSMA" in the remote control entry mode with the SPECIAL FUNCTION key. The baud rate and CSMA address can also be set in entry modes selected with this key. Refer to **paragraph 3.11** details on configuring the receiver for remote operation. Switch 4 of DIP switch A2S1 can be set to the on (down) position to activate the CSMA remote control. Baud rate hardware default can also be selected. The CSMA address hardware default can be selected with switch A2S2. The tuned frequency format can be set to four bytes or five bytes with A2S2. It is recommended that the WJ8711A be set to four bytes. Refer to **paragraph 2.2.5** for details on configuring DIP switches A2S1 and A2S2.

The following receiver parameters are controllable via the CSMA interface:

- local control, remote control, or remote control with local lockout,
- tuned frequency,
- BFO frequency,
- detection mode,
- IF bandwidth,
- gain mode,
- manual gain, and
- RF input path.

This section of the manual contains information necessary to enable an operator to control and monitor the above receiver parameters from an external controller on the CSMA interface. Details on how to properly format and transmit remote messages and how to read responses from the receiver are provided.

Before attempting to operate the receiver remotely, it is recommended that the operator become familiar with the operation and capabilities of the receiver by viewing the information provided in **Section III** of this manual. It is also recommended that the operator become familiar with the operation of the controller by viewing its literature.

5.4 ELECTRICAL REQUIREMENTS OF THE INTERFACE

The CSMA interface is implemented on a mini-phones jack (A2J) located on the rear panel, labeled CSMA. The sleeve of this connector is connected to chassis to ground. The center conductor carries the bidirectional serial data. For proper communications on the interface, a logic HIGH input should be +2 volts minimum. A logic LOW input should be +0.7 volts maximum. These logic levels are compatible with standard TTL and 5 volt CMOS logic drivers. With appropriate level shifting circuitry, any computer equipped with an RS-232C interface port can be used to control the WJ8711A via its CSMA interface. To reduce the adverse effects of reflections on the line, resistive terminations are recommended on each end of the interface cable. The DC bias introduced by the terminations must exceed +2.5 volts. A single resistor at each end of the cable, connected between a clean +3 to +5 volt supply and the data line, is usually adequate. Be sure that all devices connected to the CSMA interface have sufficient drive capability to transmit data onto the line. The WJ8711A CSMA port can sink up to 100 mA at a logic low output voltage of +0.7 volts.

5.5 SERIAL DATA TRANSMISSIONS

Data in serial transmissions is read from the transition of the change in state (i.e., high to low, or low to high). Data transmitters and data receivers connected on the interface exchange serial information using the NonReturn to Zero (NRZ) format. This means, in baseband transmissions, if a logic "1" is continuously sent, the signal does not return to logic "0" until a logic "0" is sent. The composition of one byte of data is shown in **Figure 5-2** with an example of the NRZ format.

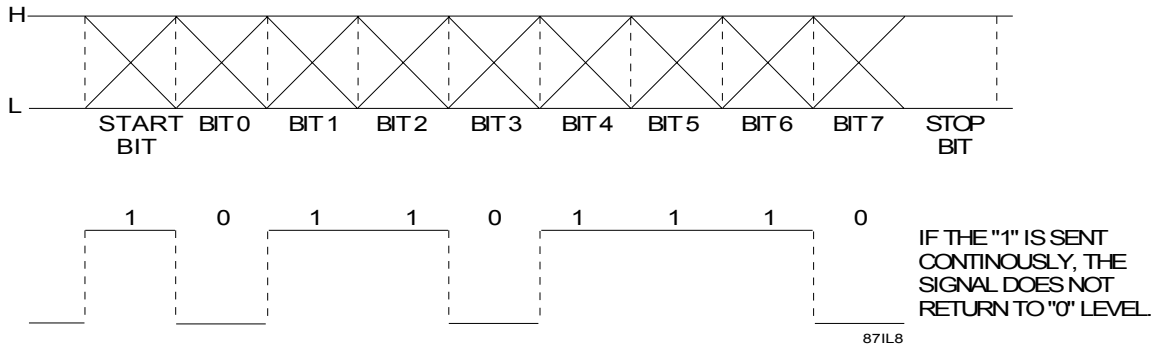

Figure 5-2. Composition of One byte of Serial Data

5.6 COMMAND MESSAGE FORMATTING

The typical message format of a command packet used with this interface is provided in **Figure 5-3**. Each block in the packet contains one byte of data. As shown in the figure the packet consists of two preamble bytes, a receiving station address byte, a transmitting station address byte, a control code byte, a varying number of data bytes, and an end of message byte. All information contained in bytes is expressed in hexadecimal except for the data bytes which may vary in number and are expressed in packed binary coded decimal (BCD).

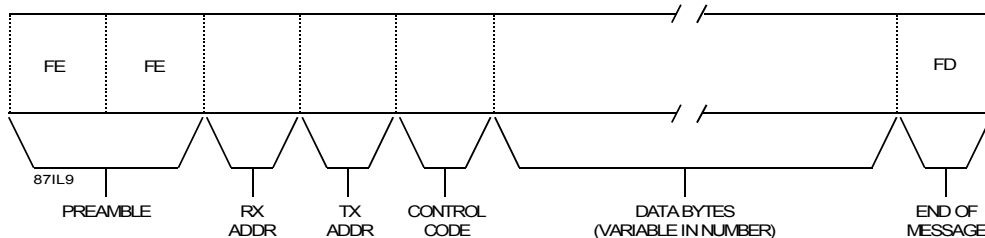

Figure 5-3. Format of Typical Command Message Packet

The preamble [FE|FE] identifies the start of a message. The receiver address (RX ADDR) identifies the address of the unit that is to receive the data. The WJ8711A's address setting should be entered at this location. The transmitting station address identifies the address of the controller sending the data. The control code represents the WJ8711A function that is to be controlled. This code should always be sent in hexadecimal format. The variable length data field contains data that accompanies the control code to set certain values of the function. This data field can contain any number of bytes required to send the data. Data in these bytes should always be sent in binary coded decimal format. The end of message byte [FD] identifies the end of the message being transmitted.

5.7 CONTROL CODES

Table 5-1 lists the control codes used for controlling the receiver functions. The control codes listed are shown in hexadecimal format. A description is provided for each control code. Data accompanying control codes is shown in decimal format unless otherwise noted.

Certain control codes require that an acknowledgment be sent to the host controller indicating that their format was valid and accepted. For all control codes that require an acknowledgment, hexadecimal FB (ACK) is returned to the controller when the control code is recognized and the accompanying data is within the specified range. Hexadecimal FA (NAK) is returned to the controller if either the control code sent is unsupported or if the accompanying data sent with a supported control code is out of range. Note that unless otherwise indicated the control code requires an acknowledge. **Figure 5-4** shows the format of ACK and NAK responses.

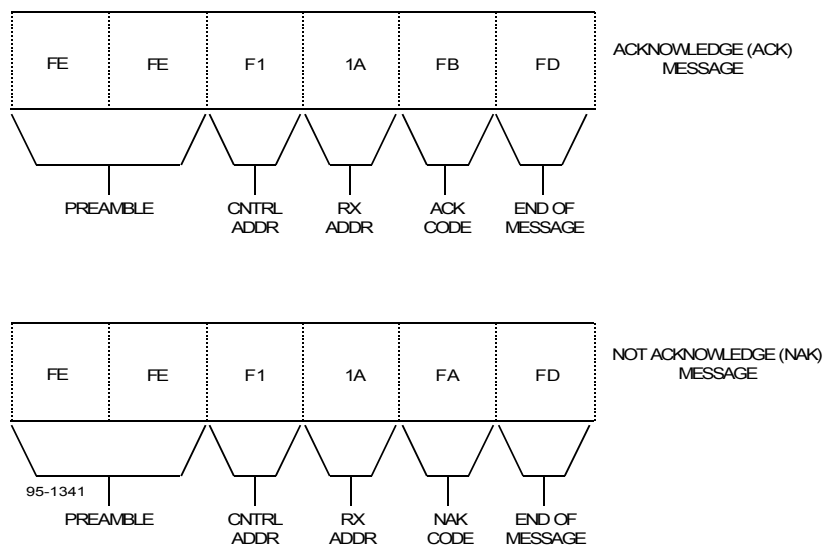

Figure 5-4. Format of ACK and NAK Messages

Table 5-1. CSMA Control Code

Control Code (Hexadecimal)	Description (Decimal)
00	Set the tuned frequency in Hz without acknowledge. Range: 00000000 - 30000000
01	Set the detection mode (first data byte) and IF bandwidth (second data byte) without acknowledge. Where: 00 - ISB 01 - USB 02 - AM 03 - CW 05 - FM 06 - ISB 07 - SAM And: 01 - 0.30 kHz 02 - 1.00 kHz 03 - 3.20 kHz 04 - 6.00 kHz 05 - 16.0 kHz
02	Request the tuned frequency range.
03	Request the tuned frequency.
04	Request the selected detection mode and IF bandwidth.
05	Set the tuned frequency in Hz with acknowledge. Range: 00000000 - 30000000
06	Set the detection mode (first data byte) and IF bandwidth (second data byte) with acknowledge. Where: 00 - ISB 01 - USB 02 - AM 03 - CW 05 - FM 06 - ISB 07 - SAM And: 01 - 0.30 kHz 02 - 1.00 kHz 03 - 3.20 kHz 04 - 6.00 kHz 05 - 16.0 kHz Note: The ISB, ISB, or USB detection modes will force the unit into the 3.20 kHz IF BW.

Table 5-1. CSMA Control Code (Continued)

Control Code (Hexadecimal)	Description (Decimal)
30	Request active gain control mode.
31	Select gain control mode with acknowledge. Where: 00 - Manual 01 - Slow AGC 02 - Fast AGC 03 - Medium AGC
32	Request the remote manual gain level.
33	Set the remote manual gain level with acknowledge. Range: 0000 - 0127
34	Request current BFO frequency.
35	Set BFO frequency in Hz (in 10 Hz steps) with acknowledge. The third data byte contains the sign in hexadecimal (0E for negative and 0A for positive). Range: -8000 to +7999 Where: +0000 = BFO Off
36	Request the device control mode.
37	Set the device control mode with acknowledge. Range: 00 - 02 Where: 00 - Local 01 - Remote 02 - Remote w/ Local Lockout
38	Request the selected RF input path.
39	Select the RF input path with acknowledge. Range: 01 - 03 Where: 01 - Normal 02 - Attenuated 03 - Preamplified

5.8 DETAILS ON COMMAND AND RESPONSE FORMATS

The following paragraphs provide examples of command and response formats for each control code listed in **Table 5-1**. In the examples, the receiver's address is assumed to be hexadecimal 1A (decimal 26) and the controller's address is assumed to be hexadecimal F1 (decimal 241). It is also assumed that the tuned frequency format is set to four bytes with A2S2 (**paragraph 2.2.5**).

5.8.1 TUNED FREQUENCY COMMAND WITHOUT ACKNOWLEDGE [00]

Figure 5-5 shows an example of the typical format for setting the receiver's tuned frequency using control code [00]. This control code provides the same result as the [05] code described in **paragraph 5.8.2** except it does not require an acknowledgment. For this reason it is not the preferred method to tune a WJ8711A.

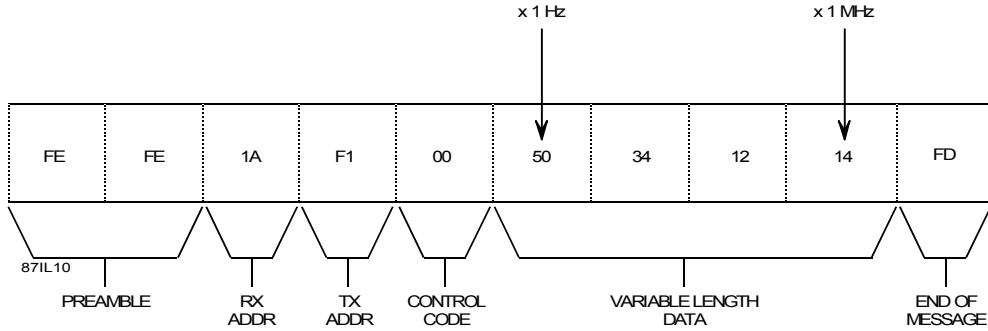

Figure 5-5. Tuned Frequency Command Format without Acknowledge

The frequency can be set to any value from 0 to 30.0 MHz at a resolution of 1 Hz. The frequency entered in the example is 14.123450 MHz. The first byte of the frequency data contains Hz data. The last (fourth) byte contains MHz data. If less than four bytes accompany the frequency control code, only those lower resolution value are changed and the higher resolution values (bytes not sent) remain the same.

5.8.2 TUNED FREQUENCY COMMAND WITH ACKNOWLEDGE [05]

Figure 5-6 shows an example of the typical format for setting the receiver's tuned frequency using control code [05]. This control code provides the same result as the [00] code described in **paragraph 5.8.1** except it requires an acknowledgment to the controller. For this reason it is the preferred method to tune a WJ8711A.

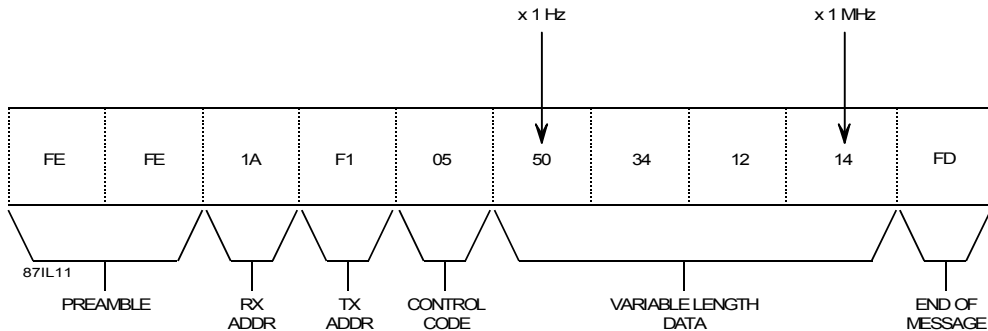

Figure 5-6. Tuned Frequency Command Format with Acknowledge

The frequency can be set to any value from 0 to 30.0 MHz at a resolution of 1 Hz. The frequency entered in the example is 14.123450 MHz. The first byte of the frequency data contains Hz data. The last (fourth) byte contains MHz data. If less than four bytes accompany the frequency control code, only those lower resolution value are changed and the higher resolution values (bytes not sent) remain the same.

5.8.3 RESPONSE TO TUNED FREQUENCY REQUESTS [03]

Figure 5-7 shows an example of the typical response format when requesting the tuned frequency with control code [03].

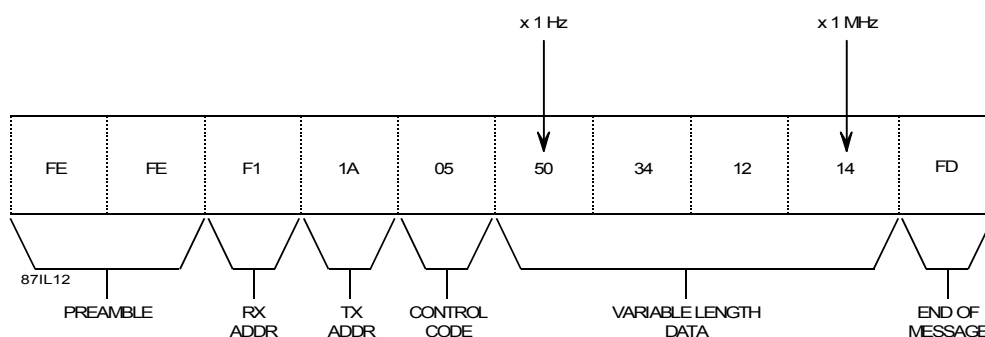

Figure 5-7. Tuned Frequency Request Response Format

The response in the example is 14.123450 MHz. The first byte of the frequency data contains Hz data. The last (fourth) byte contains MHz data. The response always contains all four bytes of the frequency data.

5.8.4 RESPONSE TO TUNED FREQUENCY RANGE REQUESTS [02]

Figure 5-8 shows an example of the typical response format when requesting the tuned frequency range of the receiver with control code [02].

In the response the upper frequency limit and the lower frequency limit are separated with 2D hex. The first byte of the frequency data in each limit of the response contains Hz data. The last (fourth) byte contains MHz data. The upper frequency limit response always contains data representing 30.000000 MHz [00|00|00|30]. The lower frequency limit response always contains data representing 0 Hz [00|00|00|00].

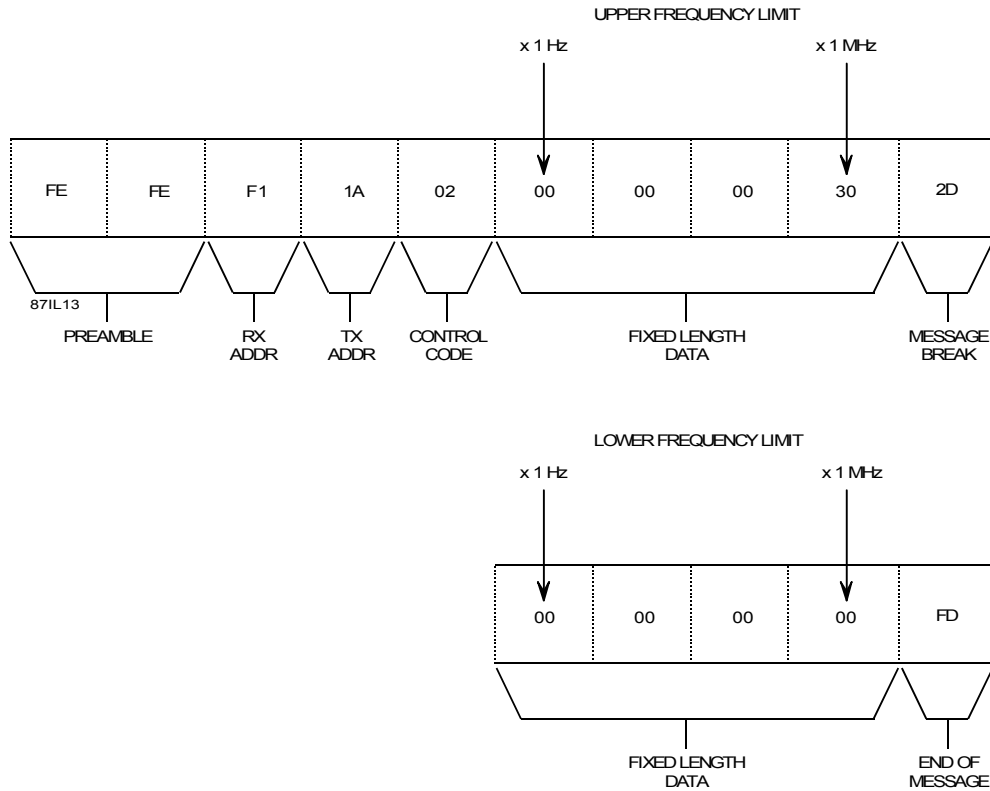

Figure 5-8. Tuned Frequency Range Request Response Format

5.8.5 DETECTION MODE/ IF BANDWIDTH COMMAND WITHOUT ACKNOWLEDGE [01]

Figure 5-9 shows an example of the typical format for selecting the receiver's detection mode and IF bandwidth using control code [01]. This control code provides the same result as the [06] command described in **paragraph 5.8.6** except it does not require an acknowledgment. For this reason it is not the preferred method to change IF bandwidth or detection mode.

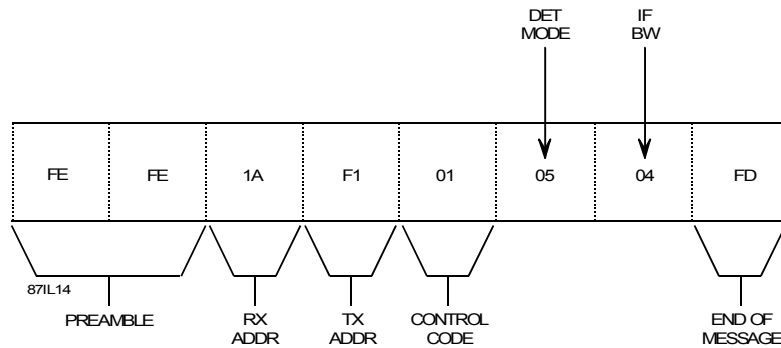

Figure 5-9. Detection Mode/ IF Bandwidth Command Format Without Acknowledge

The first byte after the control code contains the detection mode code. The second byte contains the IF bandwidth code. See control code [01] in **Table 5-1** for the detection mode and IF bandwidth choices and their codes. In the example, the FM detection mode is selected with an IF bandwidth of 6.00 kHz. The IF bandwidth byte is ignored when the detection mode byte contains codes for LSB, USB, or ISB detection modes ([00], [01], or [06]). When these detection modes are selected, the IF bandwidth is automatically set to 3.2 kHz [03].

5.8.6 DETECTION MODE/ IF BANDWIDTH COMMAND WITH ACKNOWLEDGE [06]

Figure 5-10 shows an example of the typical format for selecting the receiver's detection mode and IF bandwidth using control code [06]. This control code provides the same result as the [01] command described in **paragraph 5.8.5** except it requires an acknowledgment to the controller. For this reason it is the preferred method to change the IF bandwidth or detection mode.

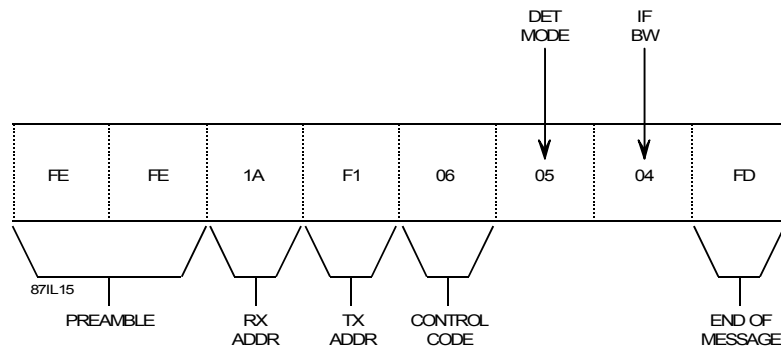

Figure 5-10. Detection Mode/ IF Bandwidth Command Format With Acknowledge

The first byte after the control code contains the detection mode code. The second byte contains the IF bandwidth code. See control code [06] in **Table 5-1** for the detection mode and IF bandwidth choices and their codes. In the example, the FM detection mode is selected with an IF bandwidth of 6.00 kHz. The IF bandwidth byte is ignored when the detection mode byte contains codes for LSB, USB, or ISB detection modes ([00], [01], or [06]). When these detection modes are selected, the IF bandwidth is automatically set to 3.2 kHz [03].

5.8.7 RESPONSE TO DETECTION MODE/ IF BANDWIDTH REQUESTS [04]

Figure 5-11 shows an example of the typical response format when requesting the receiver's detection mode and IF bandwidth with control code [04].

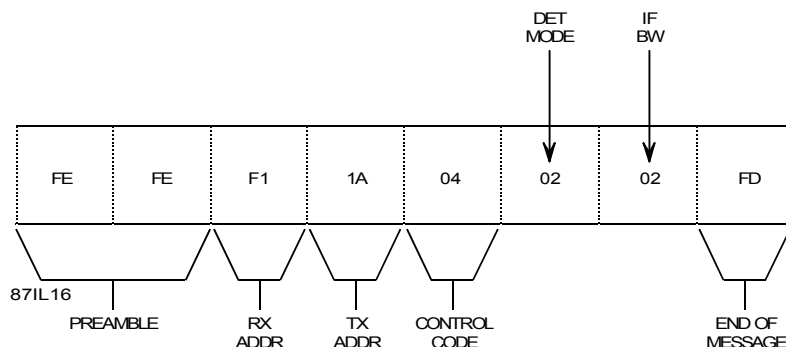

Figure 5-11. Detection Mode/ IF Bandwidth Request Response Format

The first byte in the response contains the detection mode code and the second byte contains the IF bandwidth code. The response in the example is the AM detection mode with an IF bandwidth of 1.00 kHz. See control code [01] or [06] in **Table 5-1** for the possible responses for both bytes.

5.8.8 GAIN CONTROL MODE COMMAND WITH ACKNOWLEDGE [31]

Figure 5-12 shows an example of the typical format for selecting the receiver's gain control mode using control code [31]. This control code requires an acknowledgment to the controller.

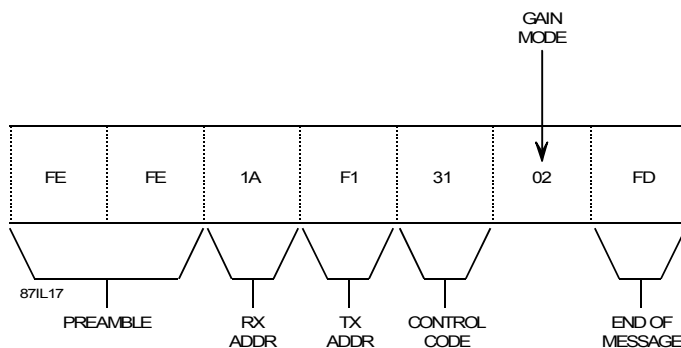

Figure 5-12. Gain Control Mode Command Format

One byte is sent with the control code. In the example, the fast AGC control mode is selected [02]. The selection can also be either slow AGC [01] or manual gain control [00].

5.8.9 RESPONSE TO GAIN CONTROL MODE REQUESTS [30]

Figure 5-13 shows an example of the typical response format when requesting the receiver's active gain control mode with control code [30].

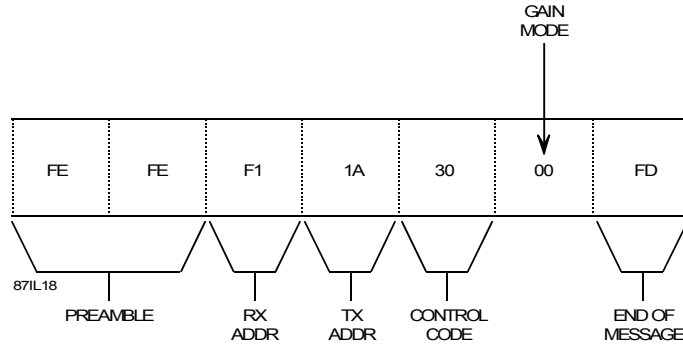

Figure 5-13. Gain Control Mode Request Format

The byte in the response after the control code contains the gain control code. The response in this byte is [00] for manual gain, [01] for slow AGC, or [02] for fast AGC. In the example, manual gain control is the response.

5.8.10 MANUAL GAIN LEVEL COMMAND WITH ACKNOWLEDGE [33]

Figure 5-14 shows an example of the typical format for selecting the receiver's manual gain level using control code [33]. This control code requires an acknowledgment to the controller.

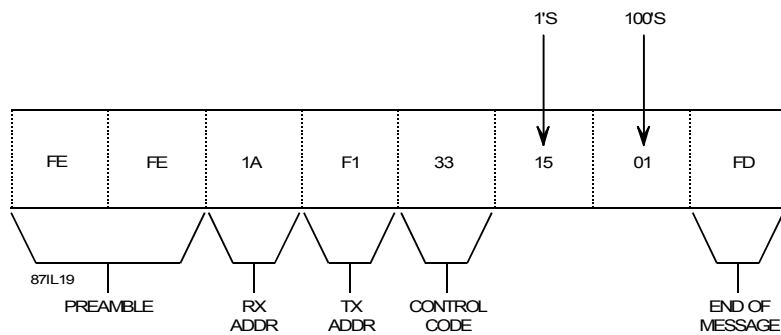

Figure 5-14. Manual Gain Level Command Format

Two bytes are sent with the control code, with the combination of both representing the value. The range is 0000 to 0127 (for 0 to 127 dB). In the example, a manual gain level of 115 dB is selected [15 | 01].

5.8.11 RESPONSE TO MANUAL GAIN LEVEL REQUESTS [32]

Figure 5-15 shows an example of the typical response format when requesting the receiver's manual gain level with control code [32].

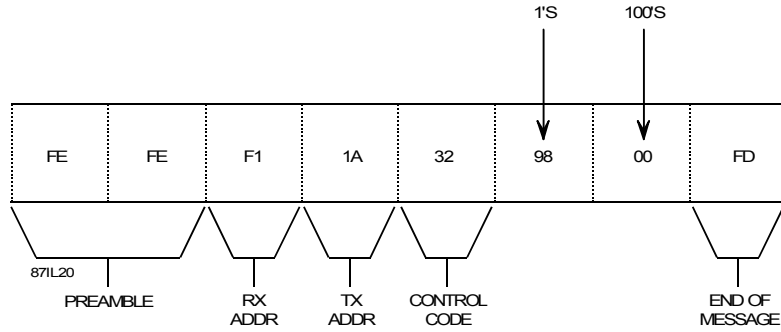

Figure 5-15. Manual Gain Level Request Format

Two bytes in the response following the control code contain the current manual gain level. The combination of the two bytes represent the value in binary coded decimal. The value can be from 0000 to 0127 (or 0 to 127 dB). In the example, the manual gain level response is 98 [98 | 00].

5.8.12 BFO FREQUENCY COMMAND WITH ACKNOWLEDGE [35]

Figure 5-16 shows an example of the typical format for sending the receiver's BFO frequency using control code [35]. This control code requires an acknowledgment to the controller.

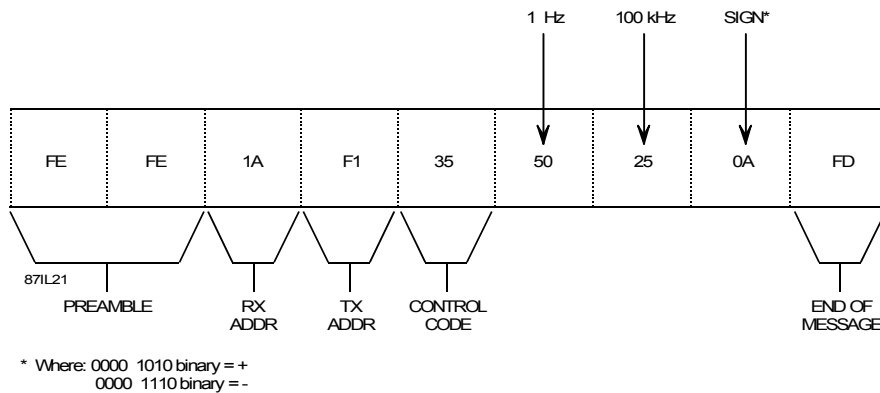

Figure 5-16. BFO Frequency Command Format

The frequency can be set to any value from +7999 to -8000 kHz at a resolution of 10 Hz. Sending +0000 sets the BFO to off. The frequency entered in the example is +2.550 kHz. The first byte of the frequency data contains Hz data. The second byte contains 100-Hz data. The third byte contains the sign, positive (+) or negative (-). For negative BFO frequencies, a hexadecimal value of [0E] should be sent in the third byte. For positive BFO frequencies, a hexadecimal value of [0A] should be sent in the third byte.

5.8.13 RESPONSE TO BFO FREQUENCY REQUESTS [34]

Figure 5-17 shows an example of the typical response format when requesting the BFO frequency with control code [34].

The response in the example is -855 Hz. The first byte of the frequency data contains Hz data. The second byte contains 100-Hz data. The third byte contains the sign, positive (+) or negative (-). A value of [0E] is returned in the third byte of the response when the frequency is a negative value. A value of [0A] is returned when the BFO frequency is positive.

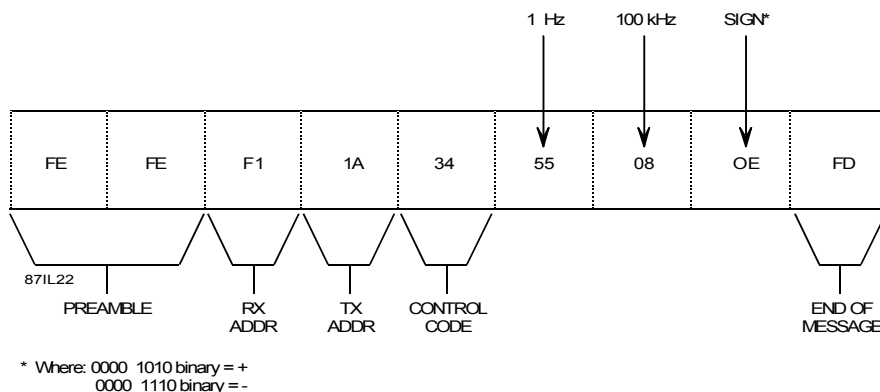

Figure 5-17. BFO Frequency Request Response Format

5.8.14 RF INPUT PATH COMMAND WITH ACKNOWLEDGE [39]

Figure 5-18 shows an example of the typical format for selecting the receiver's RF input path using control code [39]. This control code requires an acknowledgment to the controller.

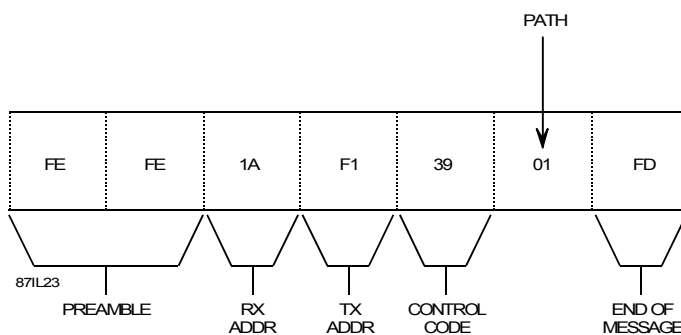

Figure 5-18. RF Input Path Command Format

One byte is sent with the control code. In the example, the normal RF input path is selected [01]. The selection can also be either attenuated [02] or preamplified [03]. The preamplifier is only allowed at tuned frequencies of 0.5 MHz and above.

5.8.15 RESPONSE TO RF INPUT PATH REQUESTS [38]

Figure 5-19 shows an example of the typical response format when requesting the receiver's current RF input path selection with control code [38].

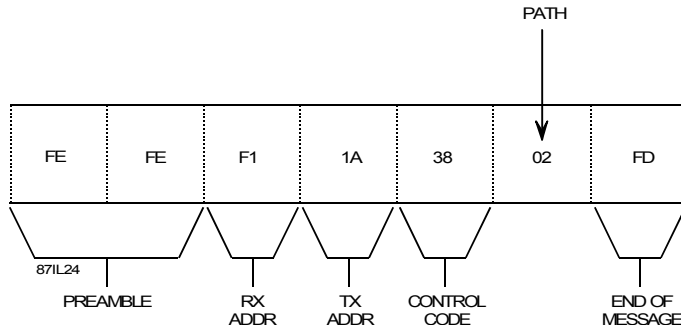

Figure 5-19. RF Input Path Request Response Format

The byte in the response after the control code contains the RF input path code. The response in this byte is [01] for normal, [02] for attenuated, or [03] for preamplified. In the example, the attenuated RF input path is selected.

5.8.16 DEVICE CONTROL MODE COMMAND WITH ACKNOWLEDGE [37]

Figure 5-20 shows an example of the typical format for selecting the receiver's control mode using control code [37]. This control code requires an acknowledgment to the controller.

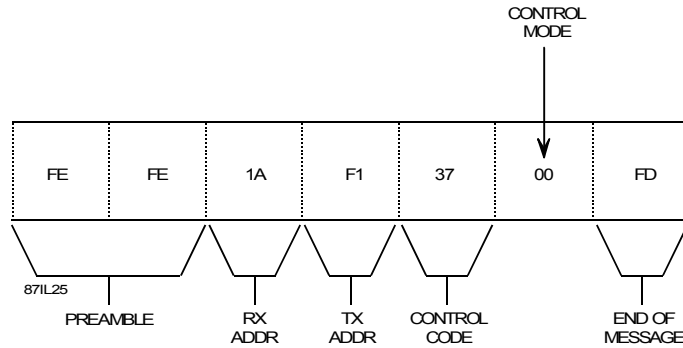

Figure 5-20. Device Control Mode Command Format

One byte is sent with the control code. In the example, the Local control mode is selected [00]. The selection can also be either Remote mode [01] or Remote with Local Lockout [02]. Sending [02] disables the WJ8711A's front panel REMOTE key (i.e., a local operator cannot place the receiver out of Remote mode).

5.8.17 RESPONSE TO DEVICE CONTROL MODE REQUESTS [36]

Figure 5-21 shows an example of the typical response format when requesting the receiver's current control mode with control code [36].

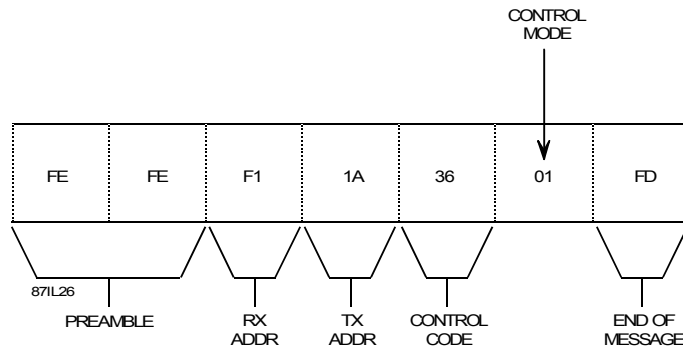

Figure 5-21. Device Control Mode Request Response Format

The byte in the response after the control code contains the device control mode code. The response in this byte is [00] for Local, [01] for Remote, or [02] for Remote with Local Lockout. In the example, the Remote control mode is selected.

5.9 COLLISION DETECTION

Many different data transmitting devices can be connected on the CSMA interface along with the WJ8711A. Therefore, there is always the possibility that two or more units may want to talk at the same time, causing “data collisions” on the interface.

The WJ8711A is designed so that it monitors all the messages that it transmits and then compares the monitored data to the transmitted data. If the transmitted data does not match the monitored data, it is assumed that a collision has occurred. The WJ8711A immediately sends the jammer codes shown in **Figure 5-22**. The WJ8711A waits for a period of time, checks for an idle interface, and then sends the original response. If another collision occurs, the process is repeated with an increased wait until the message goes through or until the fifth repetition. After five tries (each with an increased wait), the WJ8711A discards the message. Only when the controller transmits a new message does the process start again. If any device detects the jammer codes, the data that it receives is disregarded.

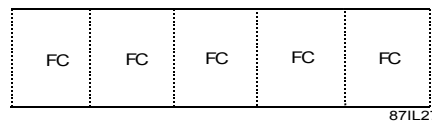

Figure 5-22. Jammer Code

SECTION 6

CIRCUIT DESCRIPTION

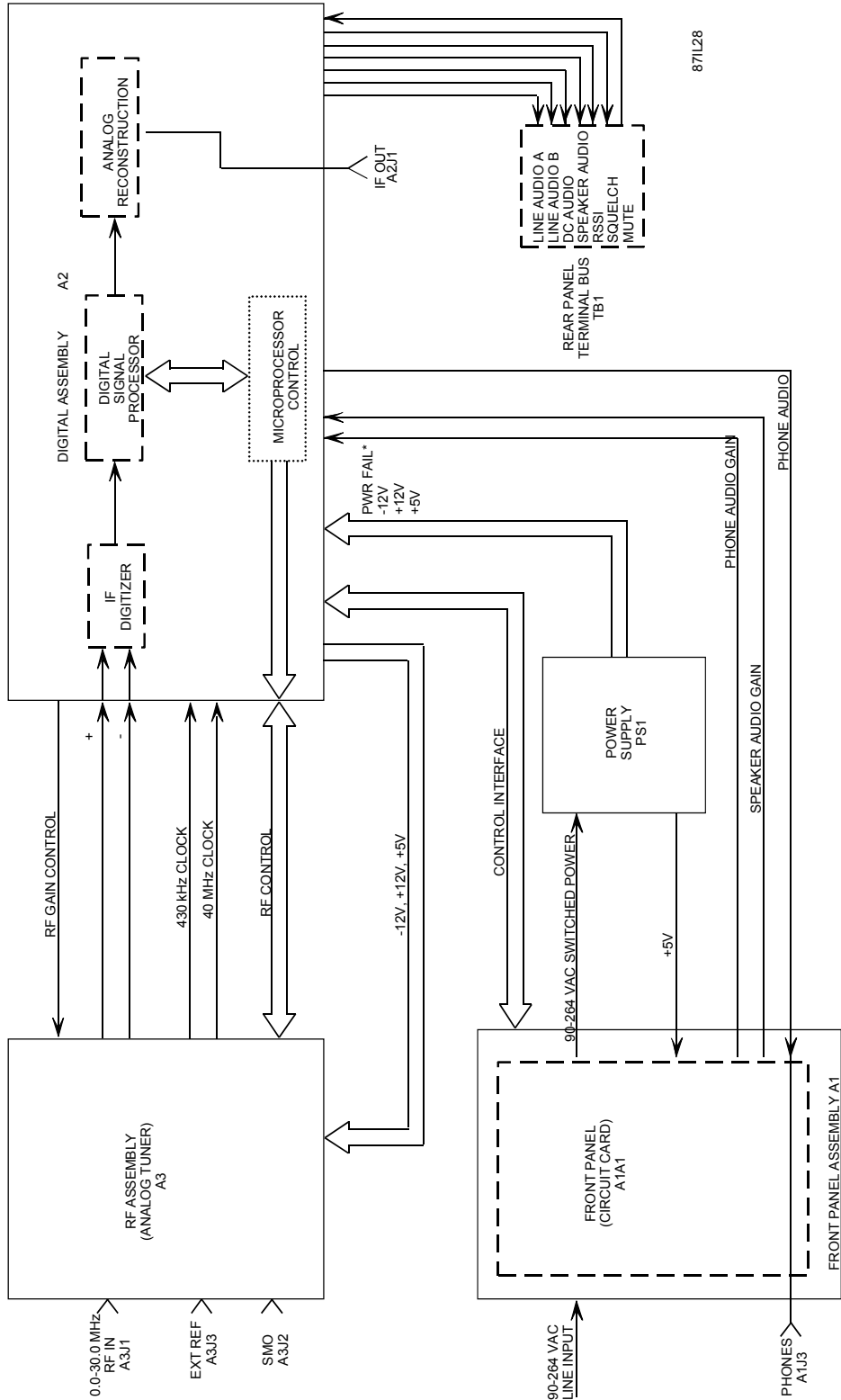

Figure 6-1. Digital HF Receiver Functional Block Diagram

SECTION 6

CIRCUIT DESCRIPTION

6.1 WJ-8711A DIGITAL HF RECEIVER FUNCTIONAL DESCRIPTION

The WJ-8711A Digital HF Receiver is a Digital Signal Processing (DSP) based receiver, consisting of an analog tuner, an IF digitizer, digital signal processing and analog reconstruction circuitry, and front panel control logic. These operating components are contained on three printed circuit assemblies, consisting of the RF Assembly (A3), the Digital Assembly (A2), and the Front Panel Assembly (A1). These three assemblies and the Power Supply (PS1) comprise the complete DSP based HF Receiver, as illustrated in **Figure 6-1**. Refer to the functional block diagram in **Figure 6-1** for the following description.

The RF Assembly (A3) functions as the analog tuner for the receiver. It performs coarse signal tuning and provides two wide band IF output signals. Three conversion stages contained in this assembly provide tuning throughout the 0 to 30.0000 MHz spectrum, with a coarse tuning resolution of 1 kHz. The RF input from the antenna enters the assembly at the rear panel RF IN connector (A3J1) and, after passing through two and three conversion stages, the tuned signal is translated into two IF outputs, respectively. The first output which is after the second conversion stage is a 455 kHz IF output, having a nominal 30 kHz bandwidth and 1-kHz resolution. It is routed directly to the rear panel Signal Monitor Output connector (SMO, A3J2). This is a 50-ohm wide band output suitable for connection of an external signal monitor. The second output which is after the third conversion stage is a 25 kHz IF output, also having a nominal 30 kHz bandwidth, that is routed to the Digital Assembly (A2) for digitizing and further processing. In addition to the 25 kHz IF signal, the RF Assembly provides two clock signals to the Digital Assembly. The 40 MHz and 430 kHz signals, derived from the receiver's local oscillators, are used for signal processing synchronization and analog reconstruction.

Timing and synchronization of the local oscillators in the RF Assembly are maintained by a precision 10 MHz reference oscillator contained on the assembly. In the standard receiver, the internal reference oscillator provides a reference stability of better than 0.7 ppm, which may be optionally upgraded to 0.2 ppm with the WJ-871Y/REF option installed. The RF Assembly reference may also be locked to an external frequency standard by connecting the external 1, 2, 5, or 10 MHz signal at the rear panel EXT REF connector (A3J3). The connection of the external reference is automatically sensed and locks the reference oscillator to the external source.

The Digital Assembly (A2) functions as the IF Digitizer, Digital Signal Processor, and Analog Reconstruction circuit for the receiver. It also contains the microcontroller circuitry that maintains control over all receiver

operations. The Digital Assembly accepts the 25 kHz IF signal from the RF Assembly, digitizes the signal, and using Digital Signal Processing (DSP) techniques, performs the majority of the signal processing operations required to produce the final outputs. The DSP circuitry on this assembly converts the digitized IF signal from a continuous time domain signal into discrete time samples that can be stored in random access memory and processed digitally to perform a wide range of operations, normally associated with analog circuitry, such as:

- Receiver Fine Tuning to a 1 Hz resolution,
- IF Bandpass Filtering,
- Determination of Input Signal Strength,
- Receiver Gain Control,
- Signal Detection and Demodulation,
- Noise Blanking.

Upon completion of the signal processing, a serial data stream representing the receiver's bandpass filtered IF signal, and the demodulated audio extracted from the tuned signal are routed to the Analog Reconstruction circuitry. The Analog Reconstruction circuitry converts the digital data back to its analog form, separates the audio and IF signals, provides post filtering, and, after completion of the analog reconstruction, provides the final audio and post filtered IF outputs. The reconstructed IF signal is converted up to 455 kHz and is provided at the rear panel IF OUT connector (A2J1) for external use. This 50-ohm output provides the 455 kHz IF at a level of approximately -20 dBm (AGC active), with its bandwidth determined by the operator selected IF bandwidth.

The reconstructed audio is separated into left and right channels and is then directed to the various receiver audio outputs. The phone audio is routed to the front panel PHONES jack (A1B) via the Front Panel circuit card assembly (A1A1). The audio signal is also provided to the rear panel terminal bus (TB1). The LINE A and LINE B audio outputs are 600 ohm balanced audio outputs, and the SPEAKER output is an unbalanced 8 ohm output. The final audio output is the DC AUDIO, which is a DC coupled, unbalanced, 1 kohm output.

The Digital Assembly also contains a microcontroller that provides an interface between an external controlling device and the receiver circuitry. A serial control interface is provided at the rear panel to permit receiver control by an RS-232 compatible computer via A2B.

Operating power is supplied to all of the assemblies in the WJ8711A Receiver by the Power Supply (PS1). This assembly accepts the incoming line voltage and converts it to the DC voltages required for proper receiver operation. It accepts an AC input ranging between 90 and 264 VAC and provides the -12 V, +12 V, GND, and +5 V outputs to the operational assemblies.

6.2 CIRCUIT DESCRIPTIONS

6.2.1 RF ASSEMBLY, (A3)

The RF Assembly (A3) functions as the RF tuner for the WJ8711A Digital HF Receiver. It receives a 0 to 30.0000 MHz input spectrum from the RF signal source and provides RF tuning to extract the signal of interest from the input spectrum. The signal of interest is converted to 455 kHz and 25 kHz IF signals that are provided as outputs for further processing. Refer to the RF Assembly Block Diagram in **Figure 6-2** as a reference for the following module description. For a more detailed illustration of the RF Assembly circuitry, refer to the Type 797006 RF Assembly schematic diagram, **Foldout FO-5**.

The RF Assembly consists of an RF Input circuit, three Mixing stages for signal conversion, a highly stable reference generator, and three local oscillators. These module sections interconnect as illustrated in **Figure 6-2** to produce the required outputs.

The reference generator uses a phase-locked-loop synthesizer to control a temperature compensated, voltage controlled crystal oscillator, producing a highly stable 10 MHz reference signal that is used as the time base for the receiver. In the standard receiver, using the Type 797006-1 or 797006-3 RF Assembly, the stability of the reference is .7 ppm. Where greater stability is required, the optional Type 797006-2 and 797006-4 assemblies provide 0.2 PPM stability. Additionally, the reference generator may be locked to an external reference by connecting an external 1, 2, 5, or 10 MHz reference signal, at a level of 200 mV rms, at the rear panel EXT REF connector (A3B). When an external input at one of the specified frequencies is present at this input, its presence is automatically sensed, and the internal 10 MHz reference generator phase-locks to the external signal. The phase-locked internal 10 MHz reference is then provided as the time base for the 1st, 2nd, and 3rd local oscillators.

The 1st IO circuit is a translation oscillator, comprised of the 1st IO VCO, a coarse tuning phase-locked-loop synthesizer, and a fine tuning phase-locked-loop synthesizer. The combined circuitry produces the variable 1st IO output, used to provide signal tuning. The output ranges from 40.455 MHz to 70.455 MHz for tuned frequencies ranging from 0.0000 to 30.0000 MHz, respectively. This output is provided to the first mixer (U28) to produce a 40.455 MHz 1st IF.

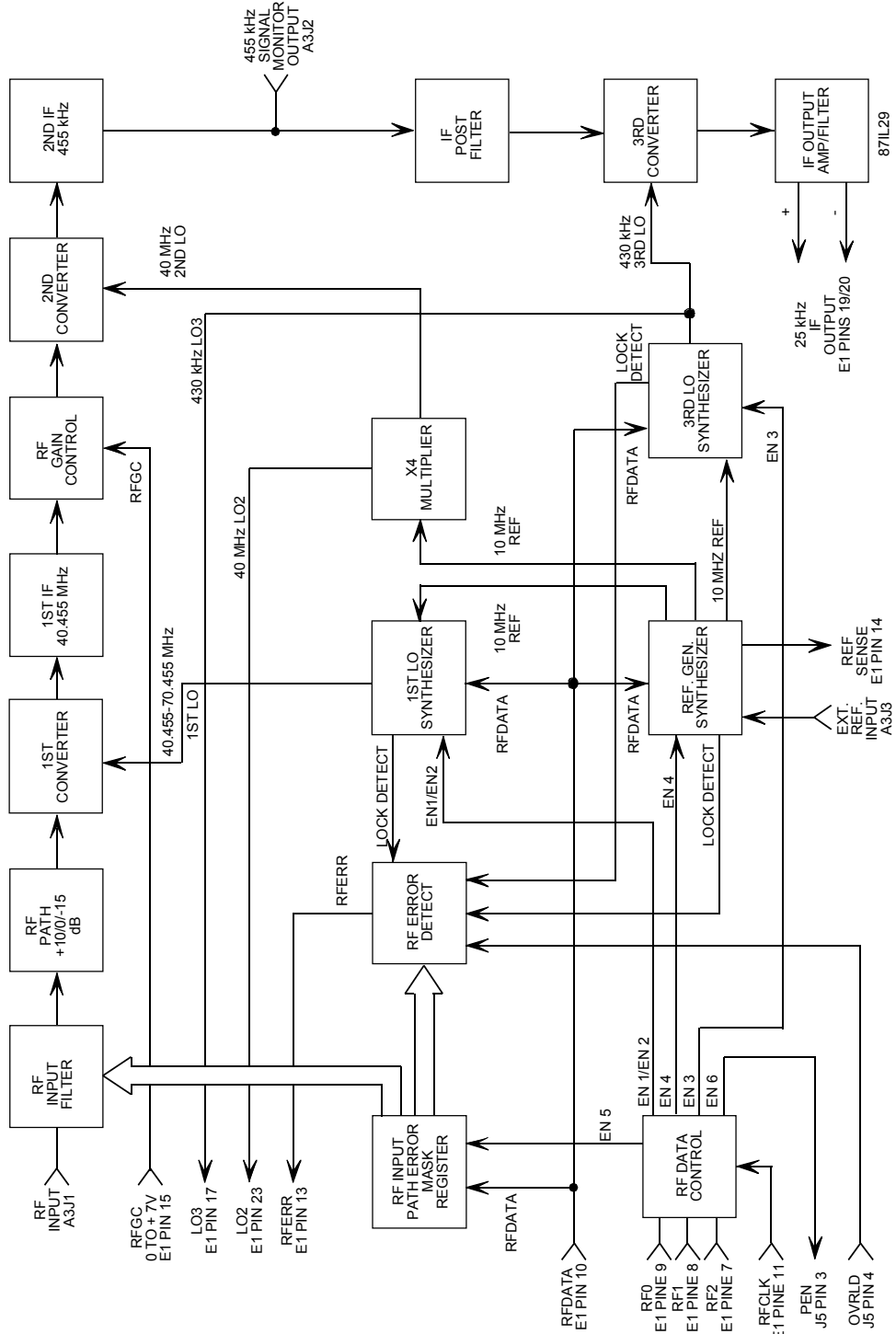

Figure 6-2. RF Assembly Block Diagram

The 2nd IO circuit produces a fixed 40 MHz output. It is produced by multiplying the 10 MHz reference signal by a factor of four. The 40 MHz output is then provided to the 2nd mixing stage (U30) to produce 455 kHz 2nd IF. The 40 MHz 2nd IO is also provided to the Digital Assembly for use as the time-base for the control microprocessor and analog to digital conversion circuitry. This signal is output via pin 23 of connector A3E1 (IO2).

The 3rd IO circuit uses a phase-locked-loop synthesizer, locked to the 10 MHz reference, to produce the fixed 430 kHz 3rd IO signal. This 430 kHz signal is provided to the 3rd mixing stage (U31) to produce the 25 kHz 3rd IF. The 430 kHz 3rd IO signal is also directed via pin 17 of A3E1 to the Digital Assembly. It is used in the Digital Assembly for analog reconstruction of the IF signal for output to the rear panel IF OUT (A2J1).

The RF/IF signal path accepts the 0 to 30.0000 MHz input spectrum, provides input filtering, and using multiple conversion stages, produces the 455 kHz and 25 kHz IF outputs. The signal enters the assembly via the 50 ohm RF IN rear panel connector (A3J1). The signal passes through a lowpass input roofing filter, having a nominal 32 MHz cutoff frequency. This permits the 0.5000 to 30.0000 MHz HF spectrum to pass while attenuating signals above the receiver tuning range. The input filtering provides improved IF and image frequency rejection. Beyond the 32 MHz cutoff frequency, the filter response drops sharply, providing approximately 80 dB of ultimate attenuation. The filtered RF input is then directed through a selectable front-end gain/attenuation control circuit, providing three operator selectable front end settings. It permits the operator to route the signal directly to the 1st conversion stage, or, depending on signal conditions, introduce front-end gain or attenuation. In the NORMAL mode, the signal is passed directly through this circuit with no effect on signal amplitude. Under weak signal conditions, the +10 dB gain path provides 10 dB of signal amplification. The third signal path is for extremely strong signal conditions. The -15 dB selection passes the signal through a 15 dB resistive pad to reduce the signal entering the receiver front end. This attenuation pad is capable of dissipating up to 1 watt to provide protection at the receiver input.

The 1st stage of conversion consists of a high intercept mixer that mixes the RF spectrum with the 1st IO signal, ranging from 40.455 MHz (0.0000 MHz Tuned Frequency) to 70.455 MHz (30.0000 MHz Tuned Frequency). The mixer output is amplified and bandpass filtered to select the 40.455 MHz difference frequency. The 1st IF filter provides a 30 kHz bandpass, centered at 40.455 kHz.

After IF filtering and amplification, the 40.455 kHz IF signal is directed to the second conversion stage, via a voltage controlled attenuator. This circuit provides control over the amplitude of the signal to the proper output level, preventing overloading of the analog to digital converter stage in the Digital Assembly. The RF GAIN input at pin 15 of connector E1 is provided by the control processor in the Digital Assembly (A2). It is the result of the DSP microprocessor sampling the value of the signal level after digitization. This voltage ranges from 0 to +7 V, providing approximately 60 dB of gain control. This voltage is strictly dependent on the signal level and is independent of the receiver's AGC or manual gain setting.

The 2nd conversion stage mixes the signal with the fixed 40 MHz 2nd IO signal, producing the 455 kHz 2nd IF. After filtering to remove the undesired mixing products, the IF signal is split into two paths. The first path directs the 455 kHz IF out to the rear panel Signal Monitor Output (SMO) connector (A3E). This provides a 50 ohm output at a level of approximately 30 dB greater than the RF Input at the RF IN connector (A3I). The Signal Monitor Output bandwidth is approximately 30 kHz wide.

The second signal path for the 2nd IF signal is through the third stage of conversion. The signal is mixed with the 430 kHz 3rd IO signal, producing the 25 kHz 3rd IF signal. After filtering, the 25 kHz IF is output, via pins 19 and 20 of connector E1, to the Digital Assembly for digitization and further processing. It is a differential output, having a level approximately 53 dB greater than the RF input. The bandwidth is approximately 25 kHz.

All control over the operation of the RF Assembly is performed by the Digital Assembly via pins 7 through 15 of connector A3E1. Connector E1 pin 15 provides a 0 to +7 V level, controlling the gain of the RF signal path. It is the result of sampling of the IF signal level after digitization. The remaining pins are used for monitoring the RF Assembly operation and sending control data for tuning and setting RF front end Gain/ Attenuation selection.

The PRE/ OPT (pin 12), RF ERR (pin 13), and REF SENSE (pin 14) are all outputs from the RF assembly to the Digital Assembly. They provide the control microprocessor with the operating status. The PRE/ OPT line (pin 12) indicates when the WJ8711A/ PRE optional Preselector is installed in the receiver. When the optional preselector assembly is present, it sets this line to logic "1", indicating to the control microprocessor that it must send preselector control data whenever the receiver is tuned. If the option is not installed, the PRE/ OPT line is held at logic "0".

The REF SENSE line (pin 14) provides an indication when an external reference is connected at the rear panel EXT REF connector (A3B). When an external reference is connected, it causes this line to assume a logic "0" condition. The control microprocessor then tunes the reference phase-locked-loop synthesizer to each of the allowable reference input frequencies, until the reference synthesizer locks on external input. If no external reference is present, the REF SENSE line remains at logic "1" and the internal reference provides the receiver time-base.

The RF ERR line (pin 13) provides the control microprocessor with an indication of the operating status of the phase-locked-loop synthesizers in the RF assembly. When the optional preselector is installed in the receiver, this line also monitors the overload protection circuitry in the preselector and activates this line during signal overload conditions. The synthesizer lock lines of the Reference, 1st IO and 3rd IO synthesizers are ORed together, along with the preselector overload line. Any synthesizer unlock or signal overload condition causes this line to assume a logic "0" condition. Once flagged by the RF ERR line, the microprocessor individually masks each of the RF ERR controlling inputs to determine the error source and reports the appropriate error condition.

Control of the RF assembly is provided via the RF0, RF1, RF2, RF DATA, and RF CIK lines (pins 7 through 11). The RF DATA line (pin 10) carries serial data from the control microprocessor to the various controlled circuits in the RF and optional Preselector Assemblies. The data is sent as a series of 8-bit data words synchronized with the data clock present on the RF CIK line (pin 11). The RF DATA line is shared by six controlled circuits each of which acts on the data only when instructed by the microprocessor via the RF0, RF1, and RF 2 control lines. These lines determine the destination of the data. **Table 6-1** lists the states of the data control lines and the associated data.

Table 6-1. RF Data Control

RF2	RF1	RF0	Strobe	Data Type
0	0	0	EN 1	1st IO Fine Loop Tuning Data.
0	0	1	EN 2	1st IO Coarse Loop Tuning Data.
0	1	0	EN 3	3rd IO Tuning Data.
0	1	1	EN 4	Reference Oscillator Tuning Data.
1	0	0	EN 5	BIIE/ NORM/ PREAMP/ ATIEN Data.
1	0	1	EN 6	Optional Preselector Band Select Data.

6.2.2 TYPE 797214 DIGITAL ASSEMBLY, (A2)

The Digital Assembly (A2) consists of three major operating sections: the Control and Interface section; the Digital Signal Processing section; and the Reconstructed Analog Section. These sections perform the IF digitization, Digital Signal Processing, Analog Reconstruction, and Receiver Control functions associated with the operation of the WJ8711A Digital HF Receiver. The assembly also provides an interface with an external computer, or other external controlling devices, and performs the control and monitoring functions that direct the receiver operation. Refer to the Digital Assembly Block Diagram in **Figure 6-3** as a reference for the following assembly description. For a more detailed illustration of the Digital Assembly circuitry, refer to the Digital Assembly Schematic Diagram, **Foldout FO-6** or **FO-6A**.

Under the direction of the Control and Interface section, the Digital Signal Processing section takes the analog IF signal supplied by the RF Assembly, digitizes it, and processes the digitized signal data to extract the signal intelligence. Other than the signal tuning performed by the RF Assembly, the Digital Signal Processing section performs all of the receiver functions that ultimately produce the final outputs. The 25 kHz IF input enters the Digital Assembly at pins 19 and 20 of **J4**. This differential input has a 25 kHz bandwidth, and ranges in level from approximately .1 to .7 V peak-to-peak at each of the input pins. The signal is directed into the IF Digitizer where the analog signal is converted into digital data that can be read by the Digital Signal Processor. A 12.8 MHz clock, provided by synchronized clock distribution circuitry in the Control and Interface section provides the timing for the analog-to-digital conversion. It causes the signal to be sampled at a 100 kHz rate, producing a series of data frames, each representing one sample of the analog input. Each frame is made up of 32 data bits, 16 of which contain the digitized IF sample. The samples are provided to the DSP circuitry where the continuous time domain signal samples are converted into discrete time samples for continuous processing. Using this data, the Digital Signal Processor, digitally performs fine tuning to a 1 Hz resolution, IF bandwidth filtering, signal strength calculations, signal demodulation, noise blanking, and receiver gain control.

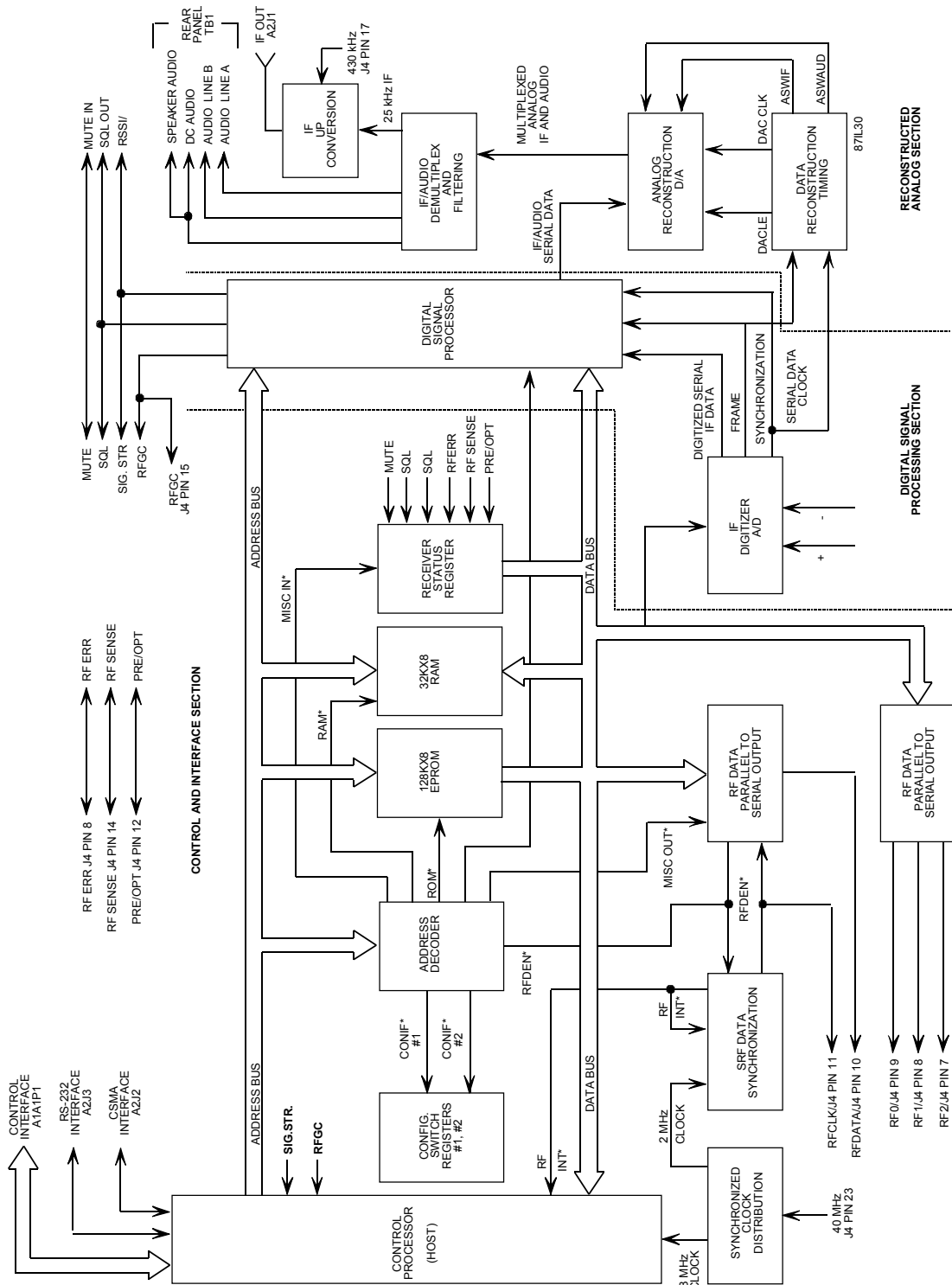

Figure 6-3. Digital Assembly Functional Block Diagram

The outputs from the Digital Signal Processing section consists of serial data containing a digital representation of the receiver's IF (limited to the selected IF bandwidth), and detected audio, multiplexed into a single data stream. This data is routed to the Reconstructed Analog section where the signals are separated, converted back to analog signals, and output to the rear panel of the receiver. It also provides analog and digital outputs to the Control and Interface section, and to the rear panel terminal bus (TB1) for monitoring. The Squelch output line at the rear panel provides a logic level that indicates to external equipment if a tuned signal exceeds the programmed Squelch level. It is set to logic "0", whenever a tuned signal exceeds the programmed level. The signal strength output is provided at the rear panel terminal bus as the RSSI output line. It is an analog voltage ranging from 0 to +5V, representing the strength of the received signal. These outputs are also provided to the Control and Interface section for monitoring. Additionally the Digital Signal Processing section provides an RF gain control output to the RF assembly (A3). This output is a result of the DSP sampling the signal level at the input to the IF Digitizer. It controls the gain of the RF section to prevent the signal from over driving the input of the IF Digitizer. The voltage ranges from approximately +7.0 V with no signal present to 0 V with strong signals present.

The Reconstructed Analog section receives the Digitized IF and audio data from the Digital Signal Processing section and converts the signals back to analog form for output. In addition to the serial data, the Digital Signal Processing section provides frame synchronization and serial data clock signals for timing of the data transfer. These timing signals permit the Reconstructed Analog section to demultiplex the signals into separate IF and audio signals. The reconstructed IF signal, converted back to a 25 kHz analog IF, is mixed with a 430 kHz local oscillator signal from the RF Assembly (A3), provided via pin 17 of J4. This mixing process up-converts the IF signal to 455 kHz. The signal is then provided to rear panel connector A2J1. This 50 ohm output provides a 455 kHz IF output, limited in bandwidth to the selected IF bandwidth. The level is approximately -20 dBm when loaded into 50 ohms.

The reconstructed audio is filtered and routed to the rear panel terminal bus as the Line A and Line B audio outputs. These are 600 ohm balanced outputs for use with external audio monitoring devices. A DC Audio output is also provided at the rear panel terminal bus. It is an unbalanced, DC coupled audio output. The final audio output is provided to the front panel PHONES jack, via the Power Distribution Assembly (A1).

The Control and Interface Section directs the operation of the RF Assembly (A3) and it directs the operation of the functions performed by the Digital Signal Processing Section, contained on this assembly.

The heart of the Control and Interface Section is the 68HC11 microcontroller. It continuously monitors the receiver functions and provides control data to direct its operation. On receiver power up, the control processor enters into a power up routine that checks the two banks of configuration switches to properly configure the external control interfaces for communication with external controlling devices, and it performs a built-in-test (BITE) operation to verify proper operation of key receiver parameters. Once the configuration and testing have been completed, the microcontroller then directs control data to the RF Assembly and the Digital Signal Processing section to set the receiver parameters for operation. The communication with the Digital Signal Processing section is via the microcontroller's address and data buses. It consists of data that determines the parameters that the Digital Signal Processor uses in processing of the tuned signal.

The transfer of control data to the RF section is performed through a ribbon cable connected at \mathcal{J}_4 . This data (RF DATA) is transferred serially as a sequence of 8-bit data words, via \mathcal{J}_4 pin 10, and provides the data to five control registers in the RF Assembly that phase locks the receiver time base; tunes the RF Assembly to the desired frequency; and selects the NORMAL, PREAMPLIFIED, or ATTENUATED RF Input Path. Three control lines (RF0, RF1, and RF2) are set as each data word is transferred, determining the destination of the data after it reaches the RF Assembly. These control lines form a three-bit address via pins 9, 8, and 7 of \mathcal{J}_4 , respectively, which are decoded by the RF Assembly to properly direct the data transfer (refer to Table 6-1). The RF DATA, and the RF0, RF1, and RF2 Control lines are synchronized with the RF clock (RFCLK), \mathcal{J}_4 pin 11. This is a sequence of 8 bit clock bursts that provide timing for the data transfer.

Three status lines, provided via connector \mathcal{J}_4 , are monitored by the Control Section to determine the operating status of the RF assembly. They are routed to a receiver status input register, and are checked periodically to verify proper operation and to determine if any control action is to be taken. The RFERR status line provides a logic level to notify the Control section if an error condition occurs. With an external reference connected to the receiver rear panel, and, with all of the phase-locked-loop synthesizers in the RF Assembly locked and operating normally, the RFERR line provides a constant logic "1". If any of the synthesizers fail, the unlocked synthesizer causes a logic "0". If no external reference is connected to the receiver rear panel, the internal reference is active, and logic "0" pulses occur at intervals of approximately 8 msec. Also, if the receiver is equipped with the RF Preselector option, a signal overload will result in a logic "0" on the RFERR line.

The Control and Interface section timing is synchronized with the receiver's time base by a 40 MHz signal, provided by the RF Assembly via \mathcal{J}_4 pin 23. This signal enters the synchronized clock distribution circuitry of the Control and Interface section, where it is used to generate an 8 MHz clock for the microcontroller, a 2 MHz clock to provide timing for transferring control

data to the RF Assembly, and the 12.8 MHz clock for timing of the analog-to-digital conversion in the IF digitizer.

Three methods of control of the receiver operation are supported by the Control and Interface section. The RS-232 interface provides a communications link from the microcontroller to a 25 pin RS-232 connector at the receiver rear panel (A2B). This is a three wire configuration that permits talk and listen capabilities, using RS-232 levels. The CSMA interface provides limited receiver control capabilities. The second form of receiver control is via the Control Interface output (A2J). This interface is routed to the Front Panel Assembly circuit card via a 24 conductor ribbon cable attached to A1A1E7.

6.2.3 FRONT PANEL ASSEMBLY (A1)

The Front Panel Assembly (A1) consists of a power switch assembly (S1) with a power on indicator (DS1), a stereo phones jack (J1), and a Front Panel circuit card assembly (A1). The front panel circuit card assembly contains; a microcontroller, three encoders, numerous switches and indicators and their associated decoding and driving circuits, and both gain controls for the PHONES and SPEAKER audio outputs. This assembly provides the man/ machine interface to the WJ8711A Digital HF Receiver. Refer to the Front Panel Assembly Functional Block Diagram in **Figure 6-4** as a reference for the following assembly description. For a more detailed illustration of the Front Panel Assembly circuitry, refer to the Front Panel Schematic Diagram, **Foldout FO-7**.

The Control Processor (A1A1U1) on the Front Panel circuit card is connected directly to the Control Processor on the Digital Assembly (A2) via a tri-state octal buffer and a CMOS Hex buffer (A1A1U18). These two microcontrollers operate in a Master/ Slave configuration, where the Master controller is on the Digital Assembly (A2). A full-duplex serial data path is provided by the MOSI (Master-Out-Slave-In) and MISO (Master-In-Slave-Out) lines, on connector E7 pins 6 and 7 respectively.

Any operations performed on the front panel such as changing the setting of one of the three encoders, adjusting the manual gain potentiometer, or changing the position of any of the front panel switches, causes the control processor to assert the Front Panel Interrupt (FPINT*) signal at E7 pin 9. The master control processor on the Digital Assembly (A2) responds by reading the registers of processor (A1A1U1) and asserting the Front Panel Acknowledge (FPACK*) signal at E7 pin 8.

Whenever the receiver is performing an operation under the control of the Digital Assembly's control processor such as sweeping or scanning, the frequency data is fed to the front panel slave processor via the MOSI data line and appears on the FREQUENCY MHz display in real time.

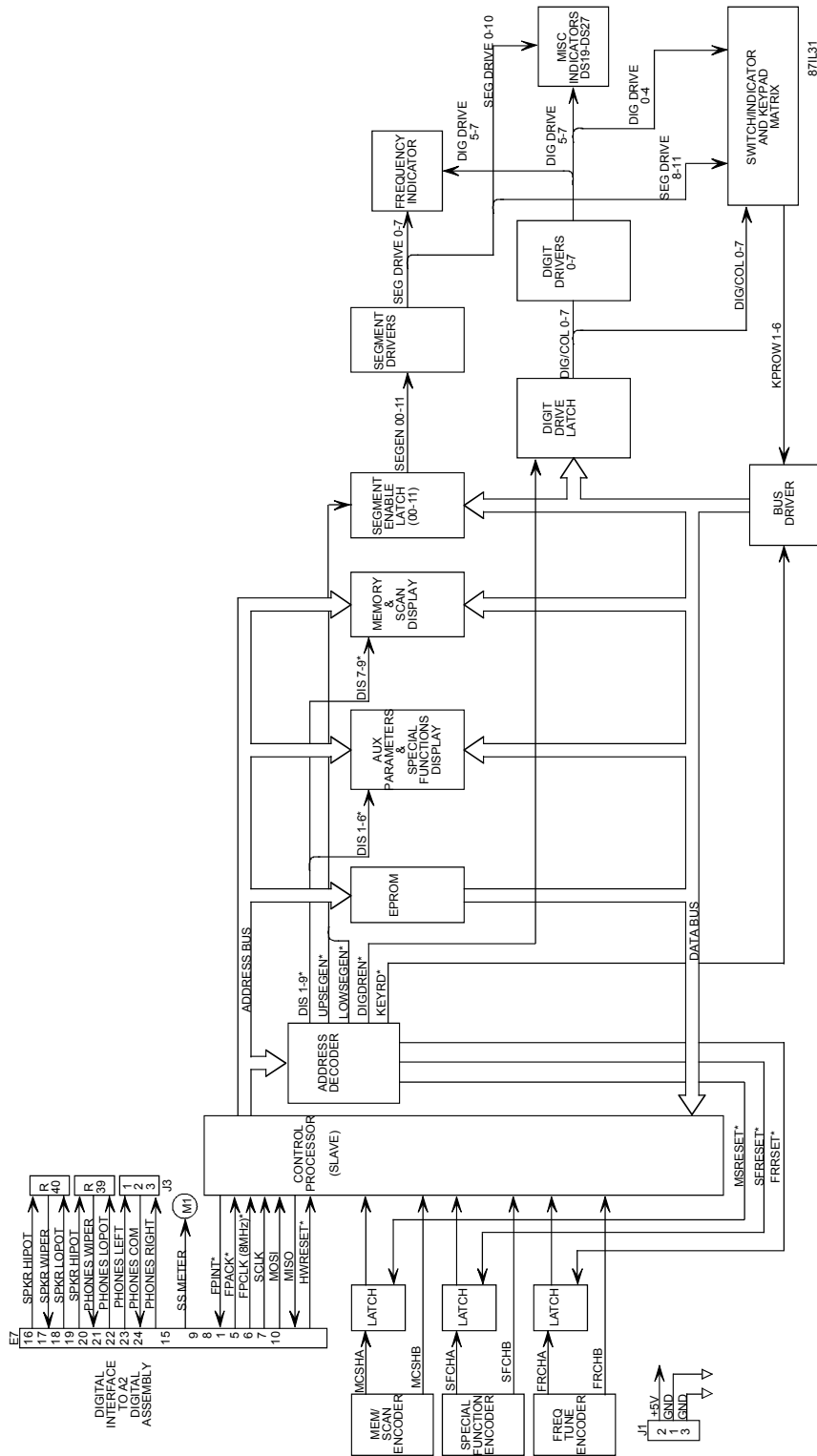

Figure 6-4. Front Panel Assembly Functional Block Diagram

6.2.4 POWER SUPPLY ASSEMBLY, (PS1)

The Power Supply, illustrated in the WJ8711A Digital HF Receiver Main Chassis schematic diagram, ***Foldout FO-8***, provides the voltages required for the proper operation of the WJ8711A Receiver.

The Power Supply is capable of providing reliable outputs over a wide range of input line voltages and frequencies. It operates from 90 to 264 VAC, at line frequencies ranging from 47 to 440 Hz. The voltage outputs under load are as follows:

	Voltage	Current (Max.)	Tolerance	Ripple (Max.)
	+5 V	3.0 A	±2%	50 mV P-P
	+12V	1.5 A	±4%	50 mV P-P
	-12V	0.5 A	±4%	50 mV P-P

SECTION 7

MAINTENANCE

THIS PAGE INTENTIONALLY LEFT BLANK

SECTION 7

MAINTENANCE

7.1 GENERAL

The WJ8711A Digital HF Receiver has been designed to operate for extended periods of time with a minimum of routine maintenance. Cleaning, inspection and performance tests should be performed at regular intervals, consistent with the facility's normal scheduling and after repairs have been made.

7.2 PREVENTIVE MAINTENANCE PROCEDURES

Preventive maintenance procedures for the receiver consist of both cleaning and scheduled preventive maintenance procedures.

7.2.1 CLEANING AND LUBRICATION

The receiver should be kept free of dust, moisture, grease and other foreign matter to ensure trouble-free operation. Use low pressure air, if available, to remove accumulated dust from the interior of the receiver. A clean, dry cloth or soft bristled brush may also be used for this purpose. No lubrication is required.

7.2.2 SCHEDULED PREVENTIVE MAINTENANCE PROCEDURES

Component A2U5 is a plug-in chip that furnishes battery power (V Batt) for the Digital Control PC Assembly (A2). U5 should be changed every eight years, or more frequently if local preventive maintenance procedures dictate. Refer to **paragraph 7.17.15** for RAM/ Battery (A2U5) removal and replacement procedures.

7.3 INSPECTION FOR DAMAGE AND WEAR

Many existing or potential troubles can be detected by making a thorough visual inspection of the unit. For this reason, as a first step in troubleshooting, a complete visual inspection should be made whenever the unit is inoperative. Inspect mechanical parts such as pin connectors and interconnecting cables for looseness, wear and other signs of deterioration. The circuit card assemblies should be checked to assure that they are properly secured to the chassis and making good electrical contact. Electronic components that show signs of deterioration, such as overheating, should be inspected and a thorough investigation of the associated circuitry should be made to verify proper operation. Often, damage due to heat is a result of other, less apparent problems in the circuit.

7.4 TEST EQUIPMENT REQUIRED

Procedures for testing the WJ8711A Receiver have been developed for performance using a minimum of common test equipment. The test equipment listed in **Table 7-1**, or equivalents, are required to perform the troubleshooting procedures and performance tests described in this section.

7.5 TROUBLESHOOTING AND FAULT ISOLATION

The test procedures that are provided in this section verify proper receiver operation and assist in fault isolation to a malfunctioning assembly. They have been developed to set known laboratory conditions that eliminate external conditions as a possible cause of the malfunction. Use performance tests in **paragraph 7.6**, and the circuit descriptions in **Section 6** to assist in fault isolation. The loss of stored parameters between receiver power-ups may be the result of the failure of the RAM/ Battery chip (A2U5). Refer to **paragraph 7.7.15** for RAM/ Battery (A2U5) removal and replacement procedures.

7.6 WJ8711A DIGITAL HF RECEIVER PERFORMANCE TESTS

The performance tests that follow are designed to verify proper operation of the WJ8711A Receiver, and each of its operational modules. In performance of the tests, the receiver may be controlled by the front panel controls or by an external controlling computer, connected to the rear panel RS-232 connector. Each procedure provides sufficient set up information to accommodate either control method.

7.6.1 POWER CONSUMPTION

1. Connect the WJ8711A Receiver and test equipment as illustrated in **Figure 7-1**.
2. Set the Clark-Hess Volt-Amp-Wattmeter function to the power mode, with the 500 ma current range selected. Set the voltage range as required for the line voltage being tested.
3. Adjust the Variable Frequency Power Source to the line frequency and voltage at which the receiver is to be operated.

Table 7-1. Required Test Equipment

Equipment	Recommended Type	Requirement
Variable Frequency Power Source	Elgar 501A	Voltage Range - 90 to 264 VAC Frequency Range - 47 to 440 Hz
Volt-Amp-Power Meter	Clark-Hess 255	Power Measurement
Signal Generator (Qty 2)	Marconi 2031	Frequency Range to 30 MHz Internal Modulation Capability
Frequency Counter	Fluke 1953A	Frequency Range to 100 MHz
RF Millivoltmeter	Boonton 92B	dB Scale Referenced to 600 Ohm Load
RF Probe	Boonton 91-12F	
"T" Adapter	Boonton 91-14A	
50 Ohm Termination	Boonton 91-15A	
AC Voltmeter	HP400EL	dB Scale Referenced to 600 Ohm Load
Distortion Analyzer	HP-334A	Harmonic Distortion Measurement
Digital Voltmeter	Fluke 8001A	AC/ DC Voltage Measurement
Oscilloscope	Tektronix 2236	100 MHz Frequency Response
Control Computer	IBM PC Compatible	RS-232 Compatible
Headphones	TELEX PH-6	600 ohm, stereo (2-channel with 1/4" tip-ring jack)

NOTE: Power requirements for the WJ8711A Receiver may range from 90 to 264 VAC, with a line frequency ranging from 47 to 440 Hz.

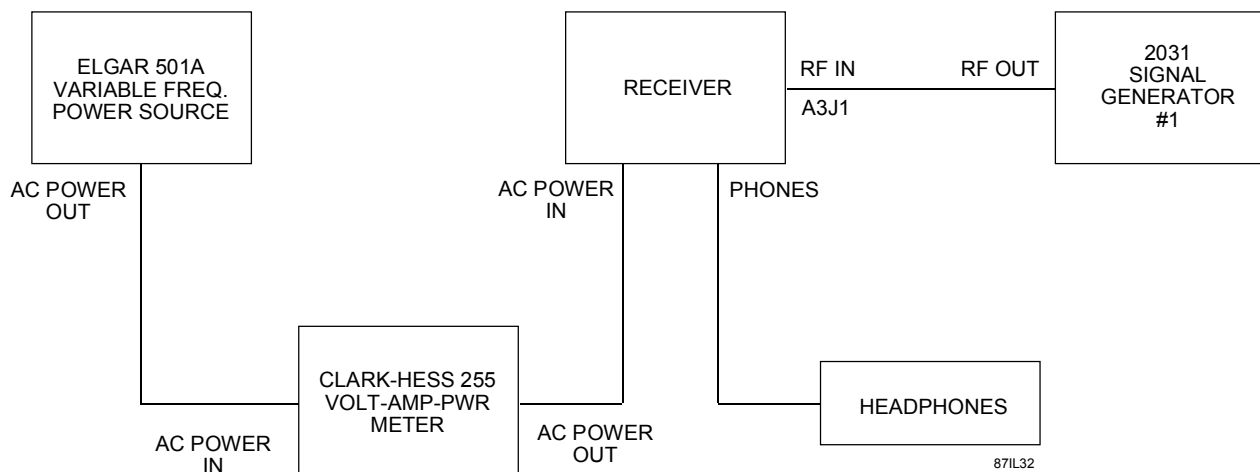

Figure 7-1. Power Consumption Performance Test Equipment Connection

4. Set the Signal Generator to produce a 1.0000 MHz output at a level of -90 dBm. Set the generator modulation for 400 Hz AM, 50% modulation.
5. Apply power to the receiver and set the receiver parameters as follows:

Tuned Frequency:	1.000000 MHz	FRQ 1 <Return>
Detection Mode:	AM	DET 1 <Return>
IF Bandwidth:	6.0 kHz	BW S 4 <Return>
Gain Control:	AGC Fast	AGC 2 <Return>
Squelch:	Off	SQ L136 <Return>
6. Adjust the PHONES LEVEL control for a clear 400 Hz audio tone in the headphones.
7. Verify that the power consumption level displayed on the Volt-Amp-W attmeter does not exceed 40 Watts.
8. Slowly increase and decrease the Variable Frequency Power Source by 10% of the initially set value while observing the power consumption level on the Volt-Amp-W attmeter. Verify that the power consumption throughout the $\pm 10\%$ range remains at 40 Watts or less and a clear audio tone remains present in the headphones.
9. Slowly decrease the Variable Frequency Power Source output voltage until the audio tone cuts off, indicating that the receiver has shut down. Verify that the line voltage at shut down is 90 VAC or less.

7.6.2 FRONT PANEL TESTS

1. Connect the WJ8711A Receiver and test equipment as illustrated in **Figure 7-2**.

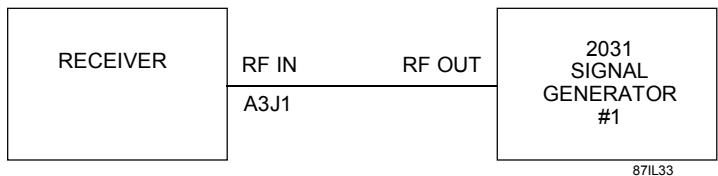

Figure 7-2. Front Panel Test Equipment Connections

2. Set up the signal generator as follows:

Frequency	1.000 MHz
Output Amplitude	-10 dBm
Modulation	None (CW)
3. Turn the WJ8711A Receiver off.

4. While observing the front panel, turn the receiver on. Upon power up, verify that all LEDs and seven segment displays will light and are of uniform brilliance. Also verify that the LED in the POWER switch is lit.
5. While viewing and FREQUENCY MHz display, rotate the Receiver tuning wheel clockwise (CW) and counterclockwise (CCW). Verify that the display indicates that CW tuning increments the display and CCW tuning decrements the display.
6. Depress the TUNE LOCK button. Verify that the LED in the button lights, and that the tuning wheel is disabled.
7. Depress the TUNE LOCK button again. Verify that the LED is extinguished and the tuning wheel is functional.
8. With the fast automatic gain control mode (FAST AGC) selected, tune the receiver to 1.000 MHz (the detection mode and IF bandwidth are not important). Verify the SIGNAL LEVEL meter reads between 0 and -20 dBm.
9. Referring the **Figure 3-1**, operate all of the pushbuttons and controls listed below. Verify that all of the controls function correctly. For keys that have associated function LEDs, ensure that the LED correctly indicates the status of the key.

Tuning Step Buttons

Numeric Keypad

AGC Button

BFO Buttons

BLANKER Button

IF BW Button

DETECTION MODE Button

SQUELCH Button

SPECIALFUNCTION Button (and all special functions)

Auxiliary Parameters Edit Knob

RF INPUT Button

SPEAKER Button

MEMORY/ SCAN Buttons

Memory/ Scan Parameters Edit Knob

7.6.3 REFERENCE FREQUENCY TIMEBASE ACCURACY

1. Connect the WJ8711A Receiver and test equipment as illustrated in **Figure 7-3**. Apply power to the receiver and test equipment and allow a warm-up period of at least 30 minutes before proceeding with the timebase testing.

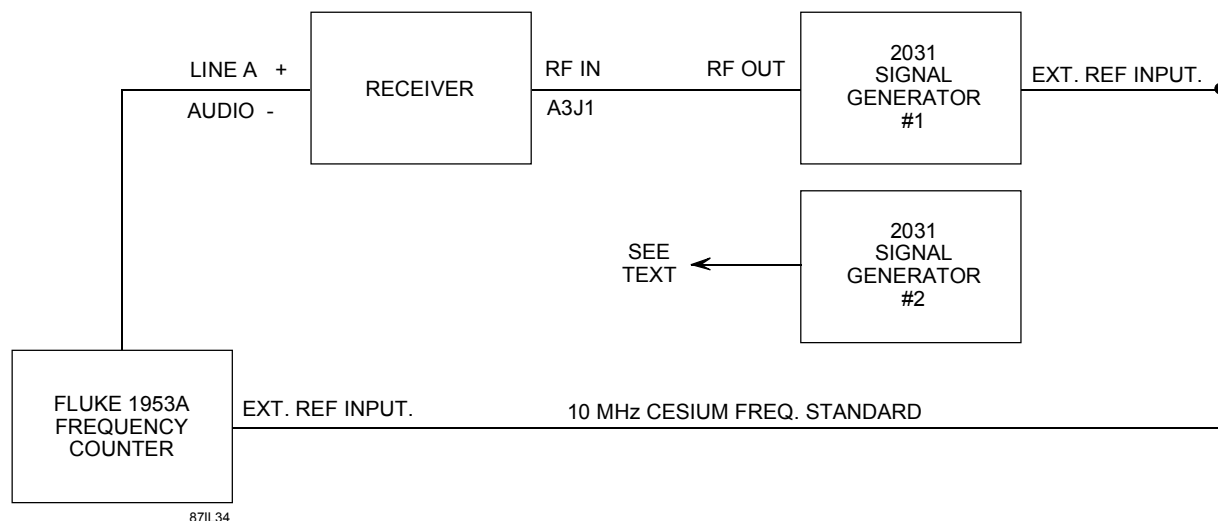

Figure 7-3. Reference Frequency Timebase Accuracy Performance Test Equipment Connection

2. Set Signal Generator #1 to produce a 30.0000 MHz CW signal at an output level of -80 dBm.
3. Set the WJ8711A Receiver as follows:

Tuned Frequency:	30.000000 MHz	FRQ 30 <Return>
Detection Mode:	CW	DET 3 <Return>
BFO Offset:	+1.00 kHz	BFO 1000 <Return>
IF Bandwidth:	6.0 kHz	BW S 4 <Return>
Gain Control:	AGC Slow	AGC 1 <Return>
Squelch:	Off	SQ L136 <Return>
4. Set the Frequency Counter for 0.1 Hz resolution.
5. Note the frequency displayed on the Frequency Counter to determine the accuracy of the receiver timebase. The displayed frequency should fall in the range between 980.0 and 1020.0 Hz.
6. Set Signal Generator #2 to produce a 10.0000 MHz CW signal at an output level of 0 dBm. Connect the Signal Generator output to the EXT. REF. connector at the receiver rear panel (A3J).
7. Note the frequency displayed on the frequency counter. This frequency should be approximately 1000 Hz, depending on the accuracy of the frequency setting in **step 2**.

- While observing the frequency counter display, slowly increase and decrease the frequency of generator #2. Verify that the frequency displayed on the frequency counter changes with changes in the generator frequency, indicating that the receiver timebase is locked to the external reference.

NOTE: The magnitude of change on the frequency counter does not match the generator changes due to frequency scaling within the receiver.

7.6.4 FINE TUNING ACCURACY

- Connect the WJ8711A Receiver and test equipment as illustrated in **Figure 7-4**.



Figure 7-4. Fine Tuning Accuracy Performance Test Equipment Connection

- Set the signal generator to produce a 10.000000 MHz CW signal at an output level of -40 dBm.
- Set the WJ8711A Receiver as follows:

Tuned Frequency:	10.000000 MHz	FRQ 10 <Return>
Detection Mode:	CW	DET 3 <Return>
BFO Offset:	+1.00 kHz	BFO 1000 <Return>
IF Bandwidth:	16.0 kHz	BW S 5 <Return>
Gain Control:	AGC Slow	AGC 1 <Return>
Squelch:	Off	SQ L136 <Return>
- Set the frequency counter for 1.0 Hz resolution.
- Note the frequency displayed on the frequency counter as a reference for the tuning accuracy tests. The displayed frequency is the difference between the receiver and the signal generator frequencies, plus the 1000 Hz BFO offset.

6. While observing the frequency counter display, slowly increase the receiver tuned frequency in 1 Hz, 10 Hz, 100 Hz, and 1 kHz steps. Verify that the magnitude of change on the frequency counter display tracks with the receiver tuned frequency changes, maintaining a frequency that is 1 kHz greater than the difference between the signal generator and receiver frequencies.

NOTE: Maintain tuned frequencies between 10.000000 and 10.008000 MHz to avoid exceeding the 16.0 kHz IF bandwidth limitations.

7.6.5 SIGNAL STRENGTH ACCURACY

1. Connect the HP-8640B Signal Generator to the RF Input of the WJ8711A Receiver (A3J1).
2. Set the signal generator to produce a 15.0000 MHz CW signal at an output level of -100 dBm.
3. Connect the digital voltmeter between the RSSI pin and ground on the rear panel terminal bus (TB1). Set the digital voltmeter function to DC Voltage, 10 V range.
4. Set the WJ8711A Receiver as follows:

Tuned Frequency:	15.000000 MHz	FRQ 15 <Return>
Detection Mode:	CW	DET 3 <Return>
BFO Offset:	+0.00 kHz	BFO 0 <Return>
IF Bandwidth:	6.0 kHz	BW S 4 <Return>
Gain Control:	AGC Slow	AGC 1 <Return>
Squelch:	Off	SQ L136 <Return>

5. Slowly increase the signal generator output level to 0 dBm, in 10 dB increments. At each increment, note the DC voltage displayed on the digital voltmeter and verify the receiver signal level using the "SGV?" query. On the Front Panel, observe the signal level on the signal strength meter.
6. Verify that the receiver signal strength indication remains within ± 10 dB of the signal generator output level. The DC voltage present at the RSSI output should range from approximately +1.0 V (-100 dBm) to +4.6 V (0 dBm). For each 10 dB increase of input level, the RSSI level should increase by approximately +.35 V.

7.6.6 WJ-8711A SENSITIVITY PERFORMANCE TEST

1. Connect the WJ8711A Receiver and test equipment as illustrated in **Figure 7-5**.

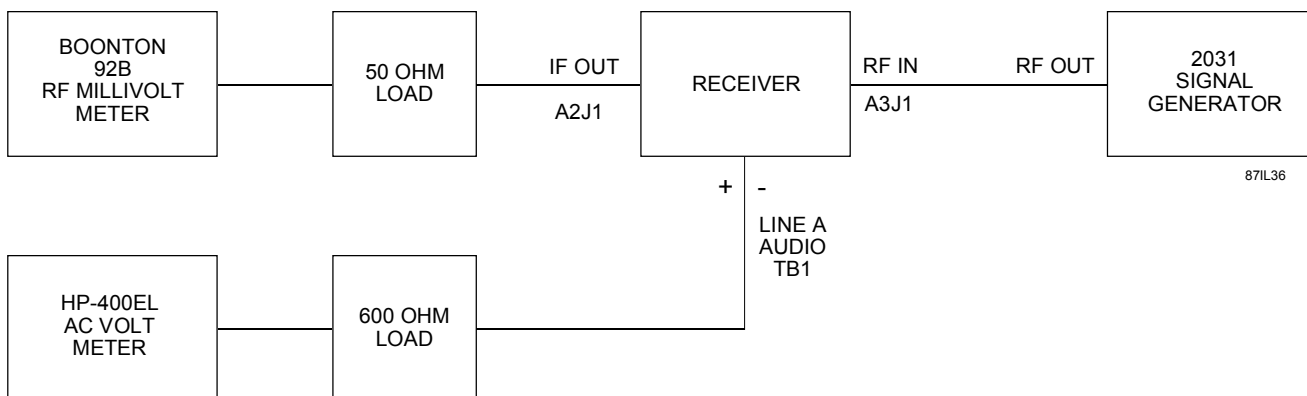

Figure 7-5. Receiver Sensitivity Performance Test Equipment Connection

2. Set the WJ8711A Receiver as follows:

Tuned Frequency:	0.500000 MHz	FRQ 5 <Return>
Detection Mode:	CW	DET 3 <Return>
BFO Offset:	+1000 Hz	BFO 1000 <Return>
IF Bandwidth:	See Table 7-2	
Gain Control:	Manual	AGC 0 <Return>
Gain Setting:	Mid-Range 060	RFG 60 <Return>
RF Input Path:	Preamplified	RFP 3 <Return>
Squelch:	Off	SQ L136 <Return>

3. Set the receiver tuned frequency to 0.500000 MHz [FRQ .5 <Return>] and set the signal generator to produce a .5000 MHz CW output at a level of -116 dBm.
4. Set the receiver IF bandwidth and the corresponding signal generator output level to each of the settings listed in **Table 7-2**. For each of the listed settings, perform the test described in **steps 5** through **8**.
5. Set the receiver RF Gain as required to produce a -20 dBm indication on the RF millivoltmeter.
6. Note the Line A audio level indicated on the AC voltmeter as the reference level for the following CW sensitivity performance test. The typical AC voltmeter indication is 0 ±3 dBm.

Table 7-2. Receiver Sensitivity Performance Test Equipment Connection

IF BW (kHz)	Command	Sig. Gen Output Level (dBm)	AM Modulation	FM Mod. Frg/ Dev.
0.30	BW S 1 <Return>	-116	100 Hz / 50%	100 Hz / 90 Hz
1.00	BW S 2 <Return>	-111	400 Hz / 50%	400 Hz / 300 Hz
3.20	BW S 3 <Return>	-106	400 Hz / 50%	400 Hz / 960 Hz
6.00	BW S 4 <Return>	-103	400 Hz / 50%	400 Hz / 1800 Hz
16.0	BW S 5 <Return>	-99	400 Hz / 50%	400 Hz / 4800 Hz

7. While observing the AC voltmeter indication, turn off the signal generator RF Output.
8. Note the AC voltmeter level with the RF signal removed. Calculate the signal-to-noise ratio by subtracting this level from the reference level noted in **step 6**. The difference between these two levels should be a minimum of 16 dB.
9. Tune the receiver and signal generator to 5.0000 MHz, 15.0000 MHz, and 29.9000 MHz. At each frequency, repeat the test described in **steps 4** through **8**.
10. Set the receiver for a .50000 MHz tuned frequency [FRQ .5 <Return>], AGC Fast [AGC 2 <Return>], and select the AM Detection Mode [DET 1 <Return>]. Set the signal generator to produce a .5000 MHz AM modulated signal.
11. Set the receiver IF bandwidth, the corresponding signal generator RF output level, and the AM modulation as listed in **Table 7-2**. For each of the listed settings, perform the test described in **steps 12** through **15**.
12. Note the Line A audio level indicated on the AC voltmeter as the reference level for the following AM sensitivity performance test. The typical AC voltmeter indication is +6 ±3 dBm.
13. While observing the AC voltmeter indication, turn the signal generator AM modulation off.
14. Note the AC voltmeter level with the AM modulation removed. Calculate the signal-to-noise ratio by subtracting this level from the reference level noted in **step 12**. The difference between these two levels should be a minimum of 10 dB.
15. Tune the receiver and signal generator to 5.0000 MHz, 15.0000 MHz, and 29.9000 MHz. At each frequency, repeat the test described in **steps 11** through **14**.

16. Set the receiver for a .50000 MHz tuned frequency [FRQ .5 <Return>], AGC Fast [AGC 2 <Return>], and select the FM Detection Mode [DET 2 <Return>]. Set the signal generator to produce a .5000 MHz FM modulated signal.
17. Set the receiver IF bandwidth, the corresponding signal generator RF output level, and the FM modulation as listed in **Table 7-2**. For each of the listed settings, perform the test described in **steps 18** through **21**.
18. Note the Line A audio level indicated on the AC voltmeter as the reference level for the following FM sensitivity performance test. The typical AC voltmeter indication is $+0 \pm 3$ dBm.
19. While observing the AC voltmeter indication, turn the signal generator FM modulation off.
20. Note the AC voltmeter level with the FM modulation removed. Calculate the signal-to-noise ratio by subtracting this level from the reference level noted in **step 18**. The difference between these two levels should be a minimum of 17 dB.
21. Tune the receiver and signal generator to 5.0000 MHz, 15.0000 MHz, and 29.9000 MHz. At each frequency, repeat the test described in **steps 17** through **20**.
22. Set the receiver for a .50000 MHz tuned frequency [FRQ .5 <Return>], Manual Gain [AGC 0 <Return>], select the ISB Detection Mode [DET 6 <Return>] and select the 3.2 kHz IF bandwidth [BWS 3 <Return>]. Set the signal generator to produce a .5010 MHz CW output signal, at a level of -113 dBm.
23. Set the receiver RF Gain as required to produce a -20 dBm indication on the RF millivoltmeter.
24. Note the Line A audio level indicated on the AC voltmeter as the reference level for the following SSB sensitivity performance test. The typical AC voltmeter indication is $+0 \pm 3$ dBm.
25. While observing the AC voltmeter indication, turn off the signal generator RF Output.
26. Note the AC voltmeter level with the RF signal removed. Calculate the signal-to-noise ratio by subtracting this level from the reference level noted in **step 24**. The difference between these two levels should be a minimum of 16 dB.

27. Temporarily remove the AC voltmeter and 600-ohm load from the Line A output of TB1 and connect them across the + and - terminals of the Line B output. Tune the signal generator to 1.0000 kHz below the receiver tuned frequency and repeat **steps 23** through **26** to verify the lower sideband of the ISB outputs.
28. Reconnect the AC voltmeter and 600-ohm load across the Line A output terminals.
29. Tune the receiver and signal generator to 5.0000 MHz, 15.0000 MHz, and 29.9000 MHz. In each case, set the signal generator frequency for 1.000 kHz above the receiver tuned frequency. At each frequency, repeat the test described in **steps 23** through **27**.

7.6.7 AUDIO DISTORTION PERFORMANCE TEST

1. Connect the WJ8711A Receiver and test equipment as illustrated in **Figure 7-6**.

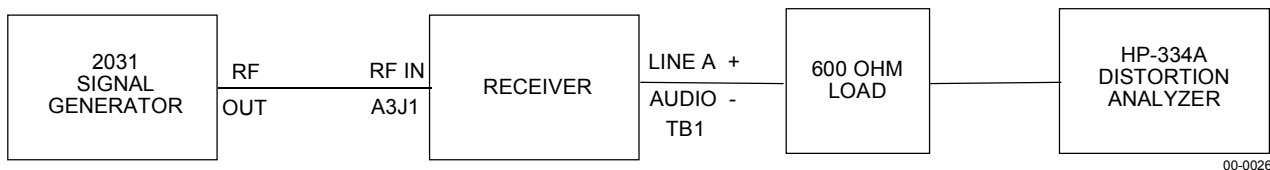

Figure 7-6. Audio Distortion Performance Test Equipment Connection

2. Set the signal generator to produce a 15.0000 MHz AM modulated signal at an output level of -50 dBm. Set the AM modulation to 400 Hz, at 30%.
3. Preset the distortion analyzer as follows:

Mode:	Manual
Frequency Range:	X10
Function:	Voltmeter
Meter Range:	1 Volt

4. Set the WJ8711A Receiver as follows:

Tuned Frequency:	15.000000 MHz	FRQ 15 <Return>
Detection Mode:	AM	DET 1 <Return>
IF Bandwidth:	6.0 kHz	BW S 4 <Return>
Gain Mode:	AGC Slow	AGC 1 <Return>
Gain Setting:	Mid-Range 060	RFG 60 <Return>
RF Input Path	Normal	RFP 1 <Return>
Squelch:	Off	SQ L136 <Return>

5. Verify that the detected audio level is 0 ± 3 dBm, as indicated on the analyzer voltmeter.

NOTE: Due to a +10 dB offset on the distortion analyzer voltmeter, the +10 dB scale is used for a 0 dBm reading.

6. Reset the distortion analyzer meter range to the 3 volt scale and increase the signal generator modulation level to 50%.
7. Set the distortion analyzer function control and meter range to the SET LEVEL positions. Adjust the distortion analyzer sensitivity control for a 100% indication on the meter (an indication of "1" on the 0-1 scale).
8. Set the distortion analyzer function control to the Distortion position. Slowly adjust the distortion analyzer Frequency control for a minimum indication on the meter. Reset the meter range as required for the best meter resolution. Verify that the total harmonic distortion measured does not exceed 5%.
9. Set the receiver detection mode to ISB [DET 6 <Return>] and the IF bandwidth to 3.2 kHz [BW S 3 <Return>].
10. Reset the distortion analyzer as follows:

Mode:	Manual
Frequency Range:	X100
Function:	Voltmeter
Meter Range:	3 Volt

11. Reset the signal generator to produce a 15.0010 MHz CW signal at a -50 dBm output level (modulation off, frequency 1.0 kHz greater than the receiver tuned frequency).
12. Verify that the detected audio level indicated on the distortion analyzer voltmeter is 0 ± 3 dBm.
13. Set the distortion analyzer function control and meter range to the SET LEVEL positions. Adjust the distortion analyzer sensitivity control for a 100% indication on the meter.
14. Set the distortion analyzer function control to the Distortion position. Slowly adjust the distortion analyzer Frequency control for a minimum indication on the meter. Reset the meter range as required for the best meter resolution. Verify that the total harmonic distortion measured does not exceed 5%.

7.6.8 SQUELCH/ MUTE PERFORMANCE TEST

1. Connect the WJ8711A Receiver and test equipment as illustrated in **Figure 7-7**.

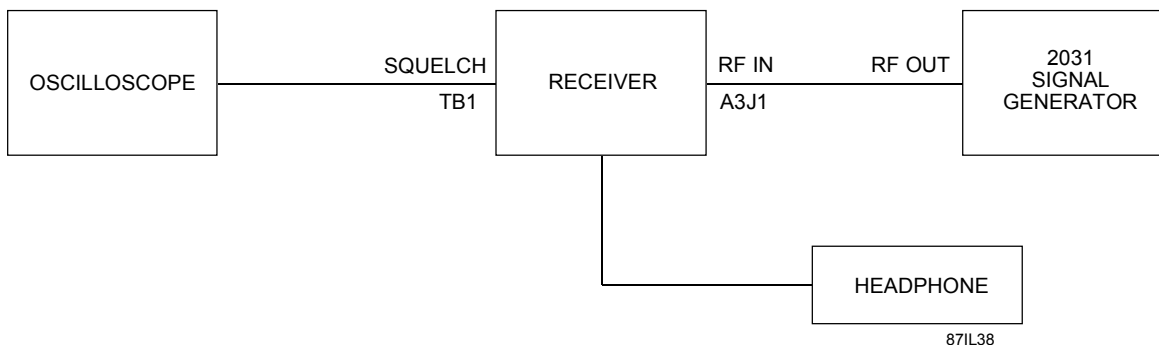

Figure 7-7. Squelch/ Mute Performance Test Equipment Connection

2. Set the WJ8711A Receiver as follows:

Tuned Frequency:	15.000000 MHz	FRQ 15 <Return>
Detection Mode:	AM	DET 1 <Return>
IF Bandwidth:	6.0 kHz	BW S 4 <Return>
Gain Mode:	AGC Fast	AGC 2 <Return>
RF Input Path	Normal	RFP 1 <Return>
Squelch:	-120	SQ L120 <Return>

3. Set the signal generator to produce a 15.0000 MHz CW output at a level of -130 dBm.
4. Observe that a steady logic "1" level (+5V) is present at the Squelch terminal of the rear panel terminal bus (TB1), as indicated on the oscilloscope.
5. While observing the oscilloscope trace, slowly increase the signal generator output level until the trace indicates a logic "0" (0V) level. Note the signal generator output level at which the squelch output switches. Verify that the signal generator output level is within ± 10 dB of the receiver squelch setting.
6. Increase the receiver squelch threshold in 10 dB increments, up to 0 dBm. At each increment, increase the signal generator output level until the oscilloscope displays a logic "0" level, indicating that the squelch has turned off. Note the signal generator output level at each switchpoint. Verify that at each level tested, the signal generator output level is within ± 10 dB of the receiver squelch setting.

7. Set the squelch to -100 dBm [SQL100 <Return>] and set the signal generator to produce a 15.0000 MHz AM modulated output, at a level of -40 dBm. Set the modulation to 400 Hz, 50%.
8. Observe that a clear 400 Hz tone is present in the headphones, and the oscilloscope indicates a logic "0" at the squelch output terminal.
9. While monitoring the headphone audio and the oscilloscope display, connect a short jumper between the MUTE terminal of TB1 and ground. Observe that the audio cuts off and after a slight delay, the squelch line switches to Logic "1".
10. Remove the jumper and verify that the audio, and the squelch logic level return to the state observed in **step 8**.

7.6.9 RECONSTRUCTED IF OUTPUT PERFORMANCE TEST

1. Connect the WJ8711A Receiver and test equipment as illustrated in **Figure 7-8**.

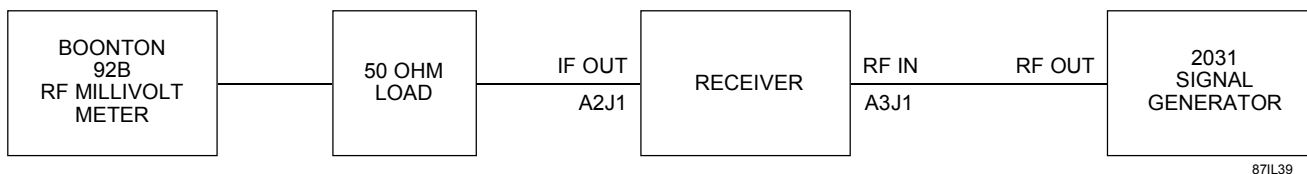

Figure 7-8. Reconstructed IF Output Performance Test Equipment Connection

2. Set the signal generator to produce a 15.0000 MHz CW output at a level of -100 dBm.
3. Set the RF millivoltmeter to the -20 dBm range.
4. Set the WJ8711A Receiver as follows:

Tuned Frequency:	15.000000 MHz	FRQ 15 <Return>
Detection Mode:	AM	DET 1 <Return>
IF Bandwidth:	16.0 kHz	BW S 5 <Return>
Gain Control:	AGC Slow	AGC 1 <Return>
RF Input Path	Normal	RFP 1 <Return>
Squelch:	Off	SQL136 <Return>
5. Note the IF Output signal level, as indicated on the RF millivoltmeter. Verify that the output level is -20 ±3 dBm (-23 to -17 dBm).
6. While observing the signal level on the RF millivoltmeter, increase the signal generator output level, in 10 dB increments, to an output level of 0 dBm. Verify that throughout the 100 dB change in the RF input signal level, the IF output level -20 ±3 dBm is maintained.

7. Decrease the signal generator output level to -115 dBm.
8. Set the receiver to the Manual Gain mode [AGC 0 <Return>] and set the manual gain to maximum [RFG 127 <Return>].
9. Adjust the signal generator output level to produce a -20 dBm reference level, as displayed on the RF millivoltmeter (Typical signal generator output level of -112 dBm).
10. Set the receiver manual gain to minimum [RFG 0 <Return>].
11. Increase the signal generator output level to +12 dBm and note the signal level indicated on the RF millivoltmeter. Verify that the RF millivoltmeter indication is less than the -20 dBm reference set in **step 9**, indicating greater than 100 dB of manual gain control.
12. Adjust the signal generator output level to -55 dBm.
13. Set the receiver manual gain to approximately mid-range [RFG 60 <Return>].
14. Increase the signal generator output level until a -20 dBm signal level reference is indicated on the RF millivoltmeter. Typically a signal generator output level of approximately -50 dBm is required.
15. While observing the RF millivoltmeter, slowly increase the signal generator frequency until the RF millivoltmeter indication decreases by 3 dB from the reference set in **step 14**. Note the signal generator frequency at this point.
16. Slowly decrease the signal generator frequency past the 15.0000 MHz tuned frequency and continue until the RF millivoltmeter again displays a 3 dB decrease from the reference level set in **step 14**. Note the signal generator frequency at this point.
16. Determine the 3 dB bandwidth of the reconstructed IF output by subtracting the value obtained in **step 16** from the value obtained in **step 15**. The calculated bandwidth should be within $\pm 10\%$ of the selected IF bandwidth, as indicated in **Table 7-3**.
17. Set the WJ8711A Receiver to each of the IF bandwidths listed in **Table 7-3**, and repeat **steps 14** through **17** for each selection.

Table 7-3. Selected IF Bandwidth Frequency Range

IF BW (kHz)	Control Command	BW Min. (kHz)	BW Max. (kHz)
0.30	BW S 1 <Return>	0.270	0.330
1.00	BW S 2 <Return>	0.900	1.100
3.20	BW S 3 >Return>	2.880	3.502
6.00	BW S 4 <Return>	5.400	6.600
16.0	BW S 5 <Return>	14.400	17.600

7.6.10 RF/ IF SIGNAL PATH PERFORMANCE TEST

1. Connect the WJ8711A Receiver and test equipment as illustrated in **Figure 7-9**.

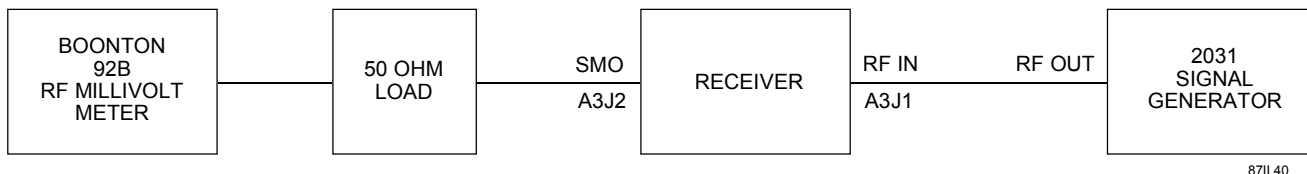

Figure 7-9. RF/ IF Signal Path Performance Test Equipment Connection

2. Set the signal generator to produce a 10.000000 MHz CW output at a level of -70 dBm.
3. Set the RF millivoltmeter to the -30 dBm range.
4. Set the WJ8711A Receiver as follows:

Tuned Frequency:	10.000000 MHz	FRQ 10 <Return>
Detection Mode:	AM	DET 1 <Return>
IF Bandwidth:	16.0 kHz	BW S 5 <Return>
Gain Control:	Manual Gain	AGC 0 <Return>
Gain Setting	Mid Range 060	RFG 60 <Return>
RF Input Path	Normal	RFP 1 <Return>
Squelch:	Off	SQ L136 <Return>
5. Adjust the signal generator output level as required to produce a -30 dBm reference level, as indicated on the RF millivoltmeter.
6. Determine the RF Assembly gain by comparing the signal generator output level with the SMO signal level indicated on the RF millivoltmeter. Typically, the signal gain ranges between 25 and 35 dB.
7. While observing the signal level on the RF millivoltmeter, slowly increase the signal generator frequency until a decrease of 3 dB, from the reference set in **step 5**, is observed. Note the signal generator output frequency at this point.
8. Slowly decrease the signal generator frequency past the 10.0000 MHz tuned frequency and continue until the RF millivoltmeter again displays a 3 dB decrease in signal level from the reference set in **step 5**. Note the signal generator output frequency at this point.

9. Determine the 3 dB bandwidth of the RF signal path by subtracting the frequency value obtained in **step 8** from the value obtained in **step 7**. The calculated bandwidth should be at least 0.0300 MHz (30.0 kHz).
10. Return the signal generator output frequency to 10.000000 MHz and adjust the output level as required to obtain a -30 dBm reference level on the RF millivoltmeter.
11. Set the RF Input path of the receiver to the ATTENUATED selection. [RFP 2 <Return>]
12. Note the signal level indicated on the RF millivoltmeter. The signal level should decrease by 15 ± 3 dB from the reference level set in **step 10**.
13. Set the RF millivoltmeter to the -20 dBm range and set the receiver RF Input path to the PREAMPLIFIED selection. [RFP 3 <Return>]
14. Note the signal level indicated on the RF millivoltmeter. The signal level should increase by 10 ± 3 dB from the reference set in setup 10.

7.7 CORRECTIVE MAINTENANCE PROCEDURES

Procedures for removal and replacement of faulty subassemblies and selected components are documented in the following paragraphs. Contact your supervisor DRS Signal Solutions, Inc. prior to breaking any factory applied inspection seals on the unit to avoid the possibility of voiding the warranty. The normal repair procedure while the unit is under warranty is to return the entire unit to the factory for warranty repair.

7.7.1 REMOVING THE RECEIVER TOP COVER

Refer to **Figure 7-10**. The following procedures are used to remove the top cover from the receiver.

1. Place the receiver in its normal upright position and remove two screws (1) from the top of the receiver, two screws (3) from the rear panel of the receiver, three screws (2) from the left side of the receiver, and three screws (4) from the right side of the receiver that secure the top cover (5) to the receiver (6).
2. Lift the top cover (5) from the receiver (6).

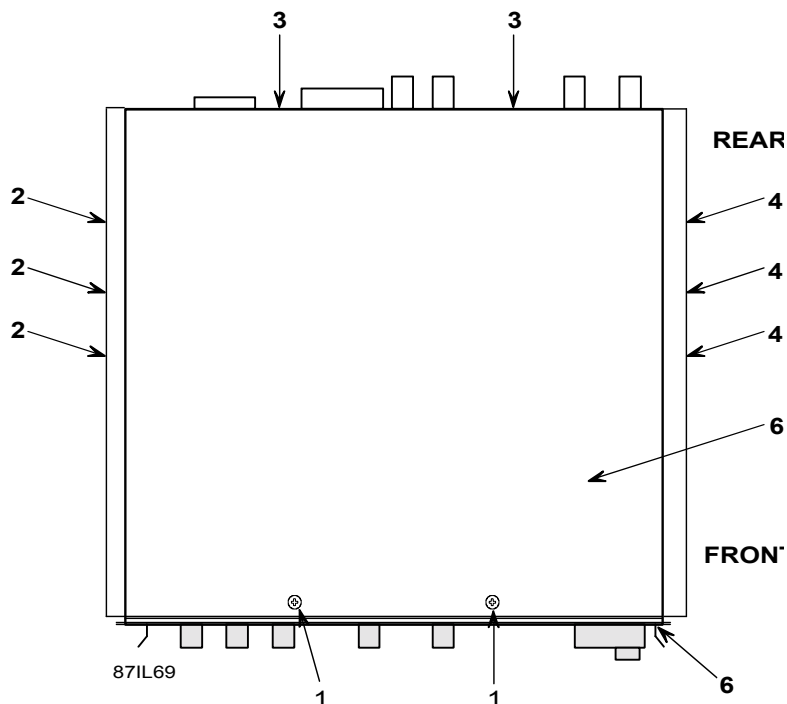

Figure 7-10. Removing/ Replacing Receiver Top Cover

7.7.2 REPLACING THE RECEIVER TOP COVER

Refer to **Figure 7-10**. The following procedures are used to replace the top cover on the receiver.

1. Place the top cover (5) on the top of the receiver(6).
2. Replace the two screws (1) in the top of the receiver, two screws (3) in the rear panel of the receiver, three screws (2) in the left side of the receiver, and three screws (4) in the right side of the receiver to secure the top cover (5) to the receiver (6).

7.7.3 FRONT PANEL ASSEMBLY (A1) REMOVAL PROCEDURES

Refer to **Figure 7-11** and **Figure 7-12**.

1. Remove plug A1A1P1 (2) from A2J7 on the Digital Control PC Assembly (1).
2. Remove plug PS1P1 (4) from A1A1J1 on the Front Panel PC Assembly (3).
3. Remove in-line plug S1P1 (5) from PS1J1. (Note: Tag or mark plug for identification purposes during replace procedures.)

4. Remove in-line plug W 1P1 (6) from S1J1. (Note: Tag or mark plug for identification purposes during replace procedures.)
5. Remove four screws (7) from the receiver front panel (8).

7.7.4 FRONT PANEL ASSEMBLY (A1) REPLACEMENT PROCEDURES

Refer to **Figure 7-11** and **Figure 7-12**.

1. Attach the Front Panel Assembly (8) to the receiver chassis using four screws (7).
2. Connect plug A1A1P1 (2) to connector A2J7 on the Digital Control PC Assembly (2).
3. Connect plug PS1P1 (4) to A1A1J1 on the Front Panel PC Assembly (3).
4. Connect in-line plug S1P1 (5) to PS1J1.
5. Connect in-line plug W 1P1 (6) to S1J1.

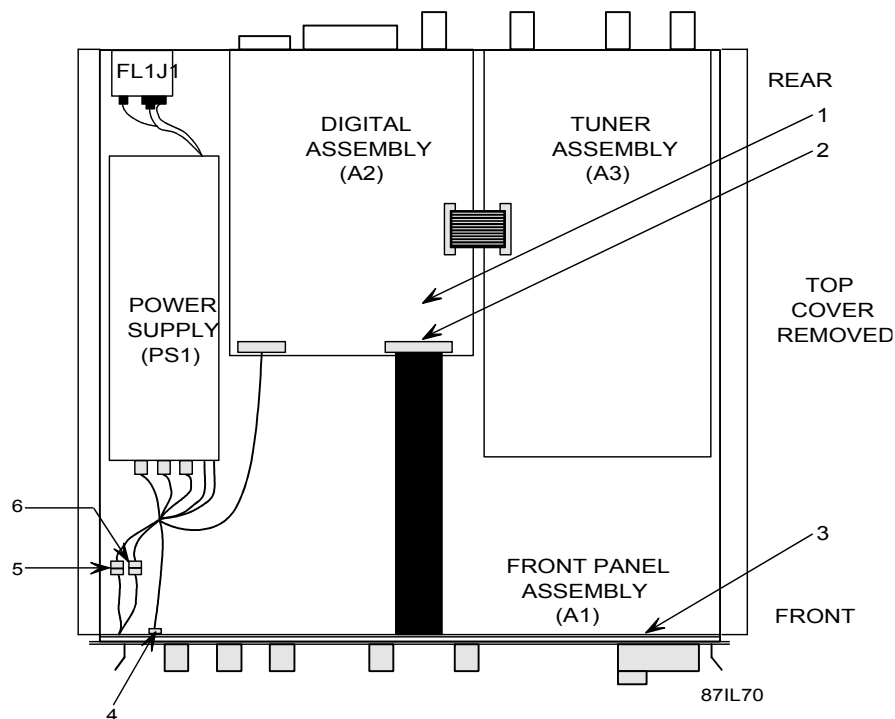

Figure 7-11. Front Panel Assembly (A1) Remove and Replace Procedures (Part 1)

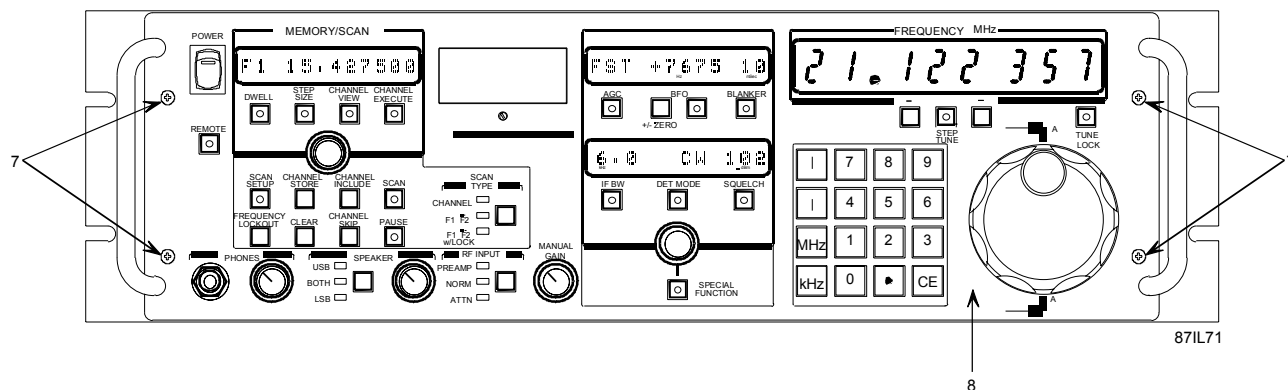

Figure 12. Front Panel Assembly (A1) Remove and Replace Procedures (Part 2)

7.7.5 FRONT PANEL PC ASSEMBLY (A1A1) REMOVAL PROCEDURES

Refer to **Figure 7-13** and **Figure 7-14**.

1. Remove five small front panel knobs (3) from the Front Panel Assembly (2) by pulling each knob forward from the shaft.
2. Remove the large tuning wheel knob (1) from the Front Panel Assembly (2) by pulling the knob forward from the shaft. After removing the large tuning wheel knob, remove the nut and washer from the shaft.
3. Turn the Front Panel Assembly over and remove the eight screws (4) that secure the Front Panel PC Assembly (5) to the rear of the Front Panel Assembly (6).

7.7.6 FRONT PANEL PC ASSEMBLY (A1A1) REPLACEMENT PROCEDURES

Refer to **Figure 7-13** and **Figure 7-14**.

1. Attach the Front Panel PC Assembly (5) to the rear of the Front Panel PC Assembly (6) by using the eight screws (4) provided.
2. Turn the Front Panel Assembly over and attach the five small front panel knobs (3) to the front panel Assembly (2) by pushing each knob onto its respect shaft.
3. Place the washer and nut on the shaft of the large tuning wheel knob (1) and tighten the nut securely on the shaft. Attach the large tuning wheel knob (1) to the Front Panel Assembly (2) by pushing it securely onto its shaft.

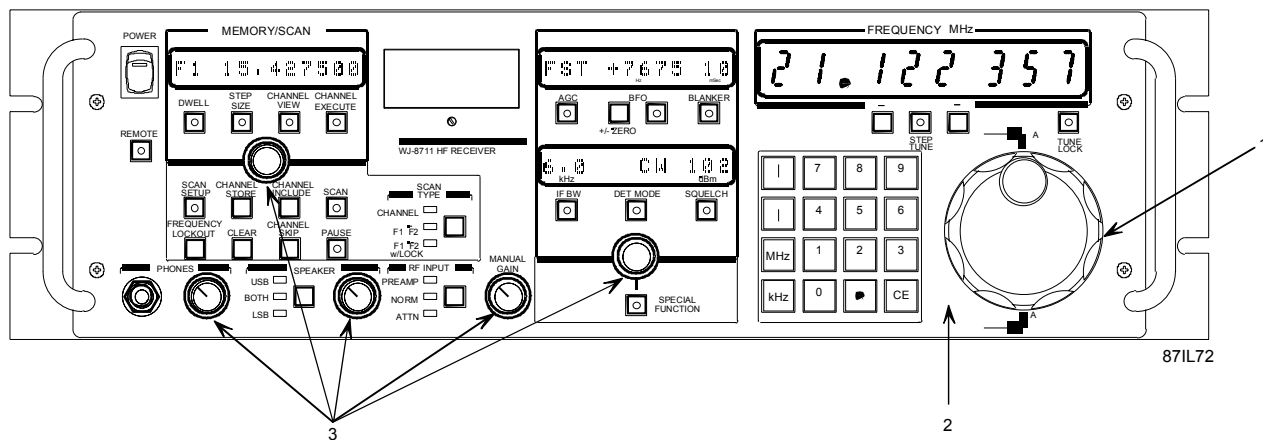

Figure 7-13. Front Panel PC Assembly (A1A1) Remove and Replace Procedures (Part 1)

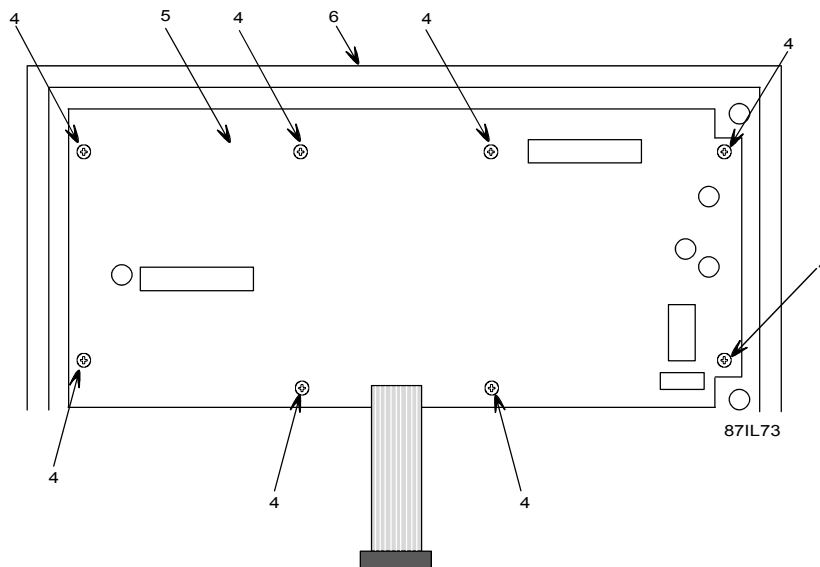



Figure 7-14. Front Panel PC Assembly (A1A1) Remove and Replace Procedures (Part 2)

7.7.7 DIGITAL CONTROL PC ASSEMBLY (A2) REMOVAL PROCEDURES

	WARNING
<p><i>This unit contains a RAM Integrated Circuit (A2U5) that includes an on-board lithium source used as back up power for memory retention. Extreme care should be used in storage, handling, and disposal of parts having lithium content. Improper handling may present explosion hazard. If the Digital Assembly is to be disposed, remove the RAM IC. If replacement of the IC is required, carefully insert a blunt, nonmetallic, tool between the bottom face of the IC and the related socket. Pry the IC up at a slight angle and remove with fingers.</i></p> <ul style="list-style-type: none">• <i>Wear eye protection when handling component with lithium content.</i>• <i>Do not puncture, compact, incinerate, short circuit, or expose the lithium energy source to temperatures above 176°F (80°C).</i>• <i>Do not store ICs with lithium content loose in bins. Store in original containers.</i>• <i>Dispose of ICs with lithium content properly. Discharged cells should be handled with care, as they retain significant energy. They should be electrically isolated and packaged for disposal. Dispose in accordance with local regulations for hazardous material disposal. DO NOT INCINERATE OR COMPACT.</i>• <i>Refer to Figure 7-23 for location of RAM IC (A2U5) on the Digital Assembly (A2)</i>	

Refer to **Figure 7-15** and **Figure 7-16**.

1. Remove the nut and washer from connector A2J1 (2) on the rear panel of the receiver (1).
2. Remove PS1P2 (6) from \mathfrak{K} on the Digital Control PC Assembly (3).
3. Remove A1A1P1 (4) from $\mathfrak{J7}$ on the Digital Control PC Assembly (3).
4. Remove A3P1 (7) from $\mathfrak{J4}$ on the Digital Control PC Assembly (3).
5. Remove six screws (5) from the Digital Control PC Assembly (3) and lift the Digital PC Control PC Assembly from the receiver.

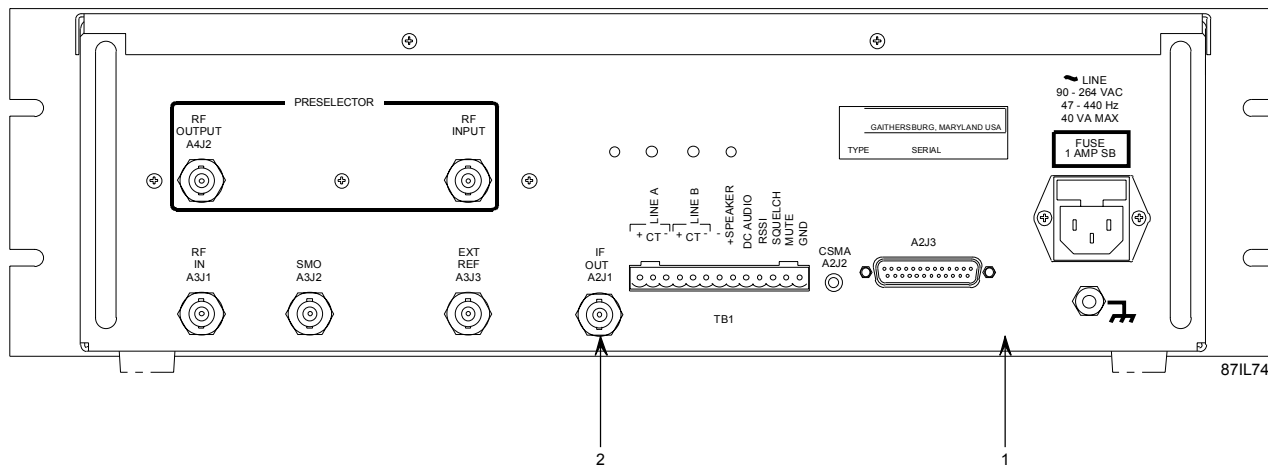

Figure 7-15. Digital Control PC Assembly (A2) Remove and Replace Procedures (Part 1)

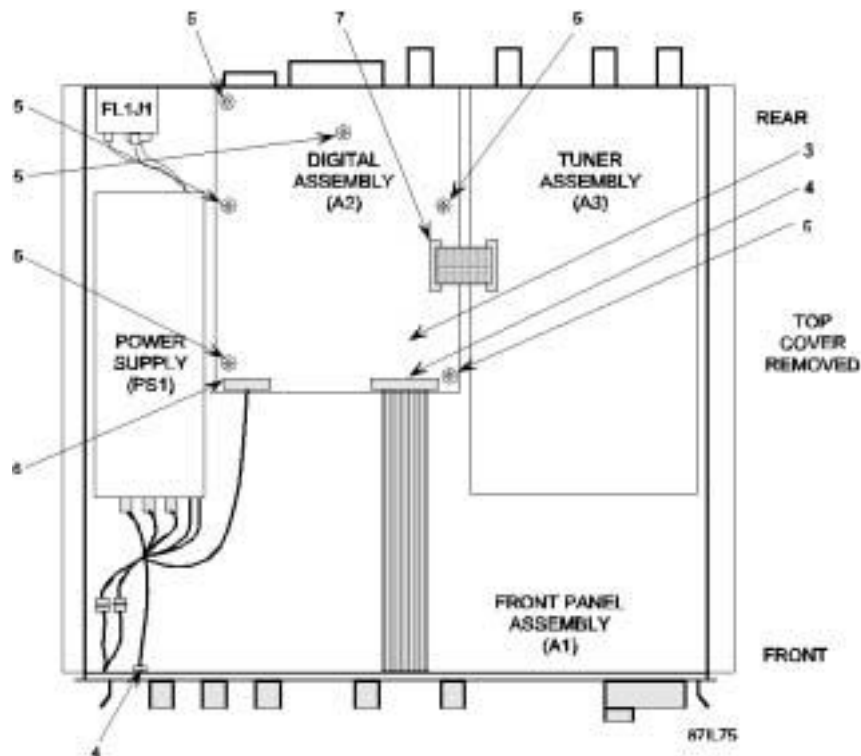

Figure 7-16. Digital Control PC Assembly (A2) Remove and Replace Procedures (Part 2)

7.7.8 DIGITAL CONTROL PC ASSEMBLY (A2) REPLACEMENT PROCEDURES

1. Secure the Digital Control PC Assembly (3) to the receiver by attaching six screws (5) securely.
2. Connect A1A1P1 (4) to J7 on the Digital Control PC Assembly (3).

3. Connect PS1P2 (6) to J5 on the Digital Control PC Assembly (3).
4. Connect A3P1 (7) to J4 on the Digital Control PC Assembly (3).
5. Replace the washer and nut on connector A2J1 (2) on the rear panel of the receiver (1). Tighten the nut securely.

7.7.9 RF TUNER ASSEMBLY (A3) REMOVAL PROCEDURES

Refer to **Figure 7-17** and **Figure 7-18**.

1. Remove the nut and washer from connectors A3J1, A3J2, and A3J3 (2) on the rear panel of the receiver (1).
2. Remove A3P1 (3) from A2J4 on the Digital Control PC Assembly (5).
3. Remove eight screws (4) from the RF Tuner Assembly (5) and lift the RF Tuner Assembly from the receiver.

7.7.10 RF TUNER ASSEMBLY (A3) REPLACEMENT PROCEDURES

Refer to **Figure 7-17** and **Figure 7-18**.

1. Secure the RF Tuner Assembly (5) to the receiver by attaching eight screws (4) securely.
2. Connect A3P1 (3) to A2J4 on the Digital Control PC Assembly (5).
3. Replace the washer and nut on connectors A3J1, A3J2, and A3J3 (2) on the rear panel of the receiver (1).

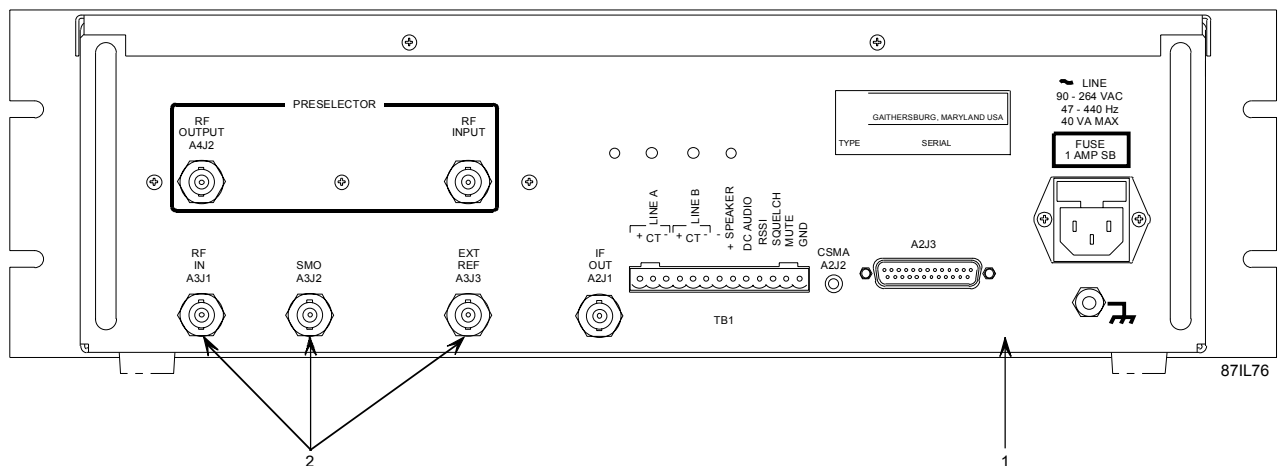

Figure 7-17. RF Tuner Assembly (A3) Remove and Replace Procedures (Part 1)

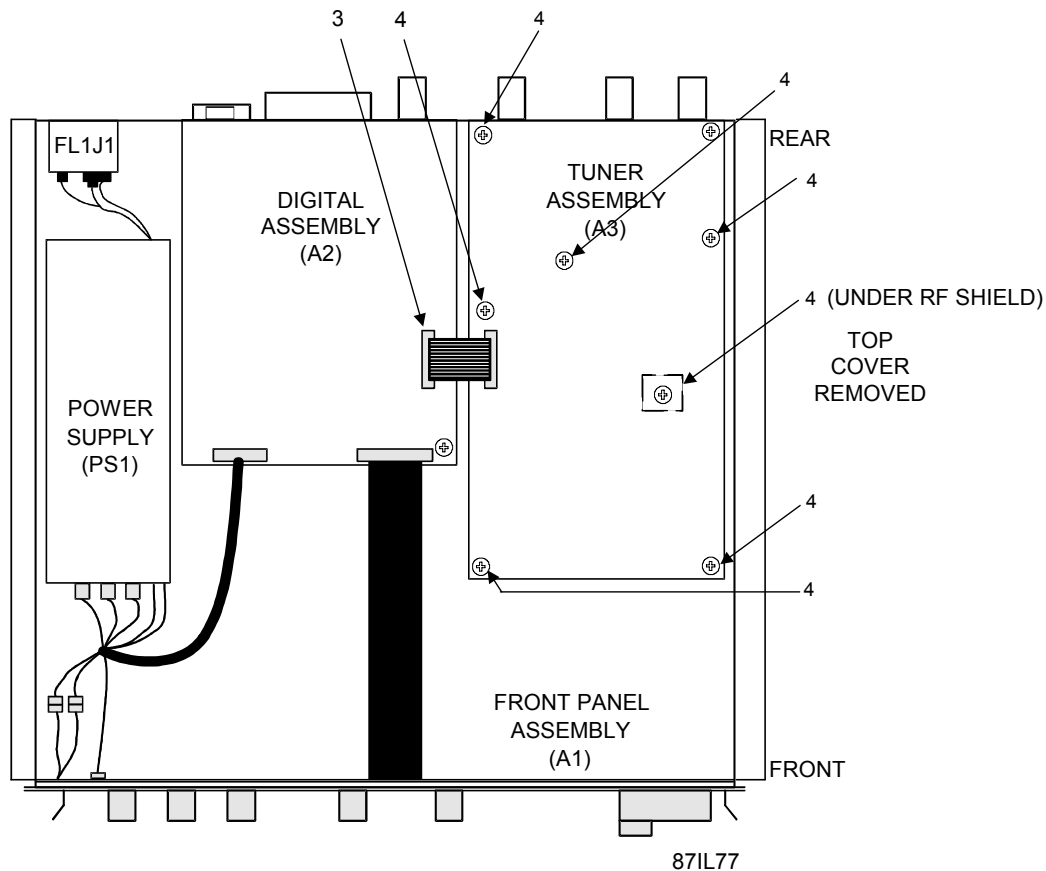

Figure 7-18. RF Tuner Assembly (A3) Remove and Replace Procedures (Part 2)

7.7.11 POWER SUPPLY ASSEMBLY (PS1) REMOVAL PROCEDURES

Refer to **Figure 7-19** and **Figure 7-20**.

1. Remove plug PS1P2 (5) from A2J5 on the Digital Control PC Assembly (1).
2. Remove plug PS1P1 (2) from A1A1J1 on the Front Panel PC Assembly (3).
3. Remove fuse (6) with connecting wire from FL1J1.
4. Remove in-line plug S1P1 (4) from PS1J1.
5. Remove four screws (8) from the left side of the receiver (7) and lift the Power Supply Assembly from the receiver.

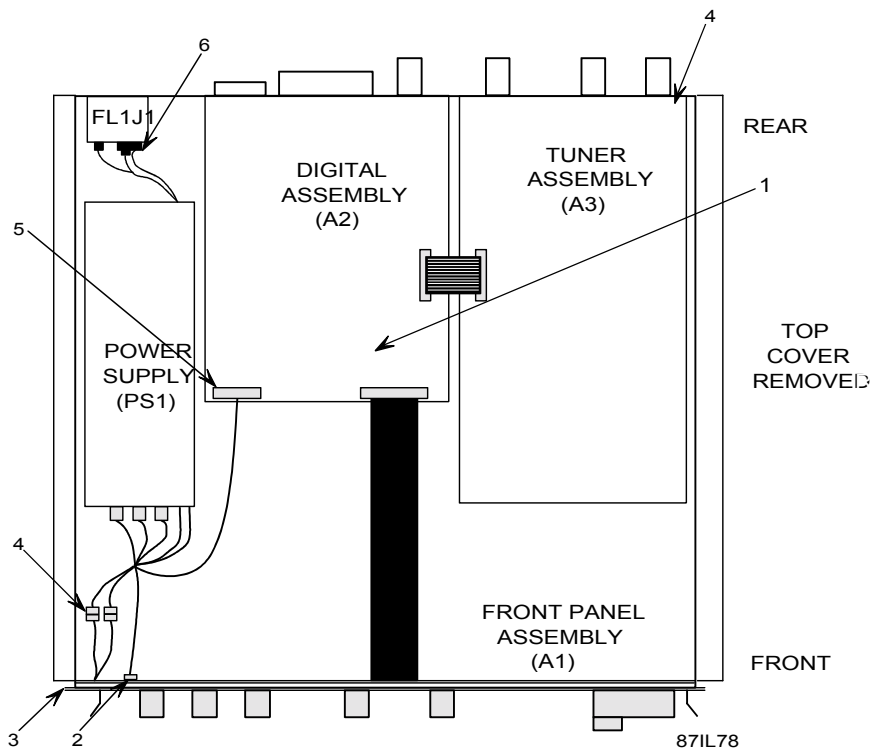

Figure 7-19. Power Supply (PS1) Remove and Replace Procedures (Part 1)

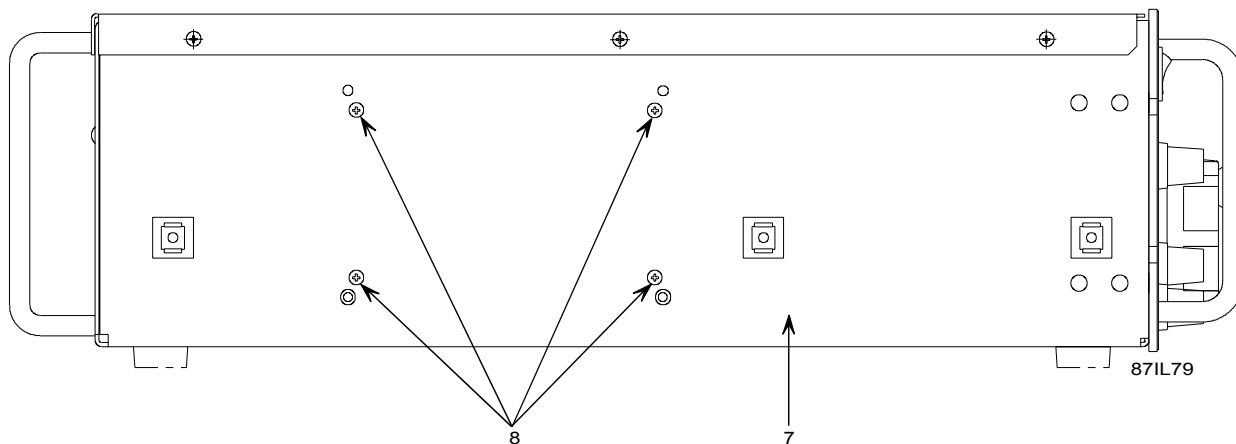

Figure 7-20. Power Supply (PS1) Remove and Replace Procedures (Part 2)

7.7.12 POWER SUPPLY ASSEMBLY (PS1) REPLACEMENT PROCEDURES

Refer to **Figure 7-19** and **Figure 7-20**.

1. Secure the Power Supply Assembly to the receiver by attaching four screws (8) to the left side of the receiver (7) securely.
2. Connect plug PS1P1 to A1A1J1 (2) on the Front Panel Assembly (3).

3. Connect plug PS1P2 to A2J5 (5) on the Digital Control PC Assembly (1).
4. Connect fuse (6) and connecting wire to FL1P1.
5. Connect in-line plug S1P1 to PS1J1 (4).

7.7.13 FILTER/ POWER (FL1J1) REMOVAL PROCEDURES

Refer to **Figure 7-21** and **Figure 7-22**.

1. Remove two wires and one fuse from the Filter/ Power module (1). (Note: Tag or mark each wire for identification purposes during replace procedures.)
2. Remove two screws (2) from the rear of the receiver (3) and lift the Filter/ Power module from the receiver.

7.7.14 FILTER/ POWER (FL1J1) REPLACEMENT PROCEDURES

Refer to **Figure 7-21** and **Figure 7-22**.

1. Secure the Filter/ Power module to the receiver (3) by securely attaching two screws (2).
2. Connect one fuse and two wires to the Filter/ Power module (1).

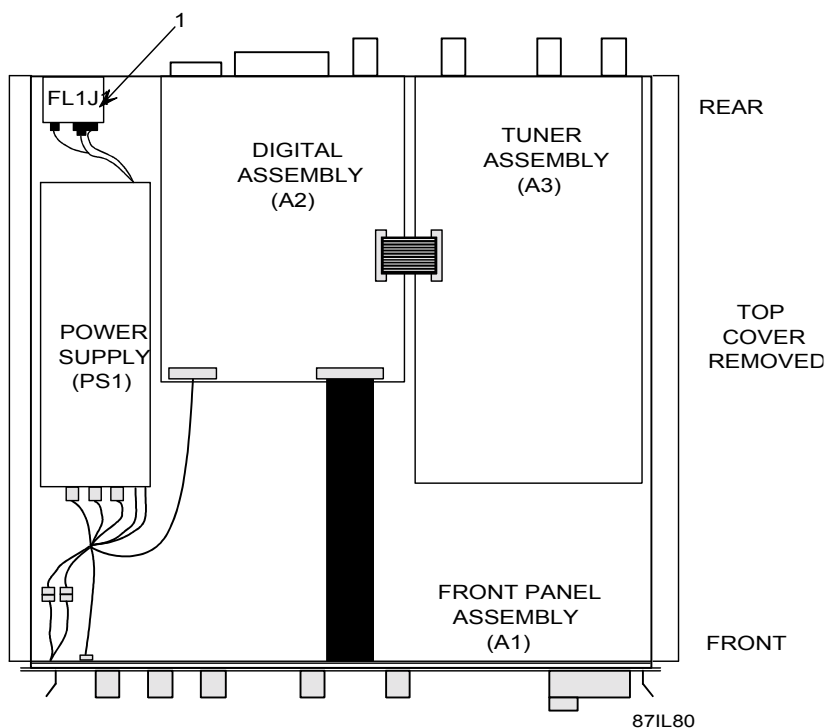

Figure 7-21. Filter/ Power (FL1J1) Removal and Replacement Procedures (Part 1)

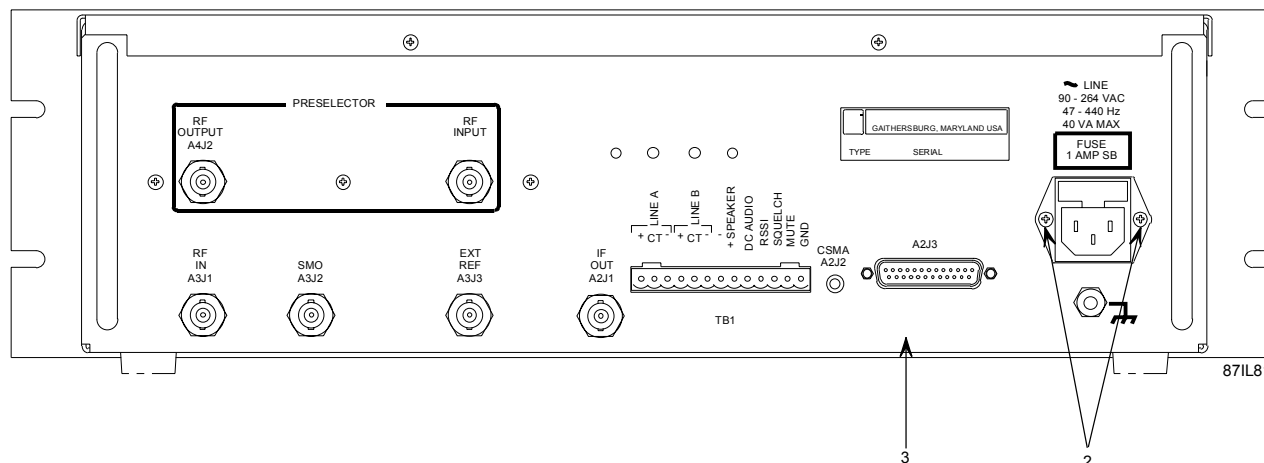

Figure 7-22. Filter/ Power (FL1J1) Removal and Replacement Procedures (Part 2)

7.7.15 RAM/ BATTERY (A2U5) REMOVAL/ REPLACEMENT PROCEDURES



WARNING

This unit contains a RAM Integrated Circuit (A2U5) that includes an on-board lithium source used as back up power for memory retention. Extreme care should be used in storage, handling, and disposal of parts having lithium content. Improper handling may present explosion hazard. If the Digital Assembly is to be disposed, remove the RAM IC. If replacement of the IC is required, carefully insert a blunt, nonmetallic, tool between the bottom face of the IC and the related socket. Pry the IC up at a slight angle and remove with fingers.

- *Wear eye protection when handling component with lithium content.*
- *Wear eye protection when handling component with lithium content.*
- *Do not puncture, compact, incinerate, short circuit, or expose the lithium energy source to temperatures above 176°F (80°C).*
- *Do not store ICs with lithium content loose in bins. Store in original containers.*
- *Dispose of ICs with lithium content properly. Discharged cells should be handled with care, as they retain significant energy. They should be electrically isolated and packaged for disposal. Dispose in accordance with local regulations for hazardous material disposal. DO NOT INCINERATE OR COMPACT.*
- *Refer to Figure 7-23 for location of RAM IC (A2U5) on the Digital Assembly (A2).*

Component A2U5 is a plug-in chip that furnishes battery power (V Batt) for the Digital Control PC Assembly (A2). U5 may require replacement as a result of failure of the battery, failure of the other functions of the chip, or as a result of preventive maintenance activities designed to periodically replace the battery.

Refer to **Figure 7-23** for the approximate location of U5 on the Digital Control PC Assembly. If your receiver contains a Digital Expansion Assembly (Options) Board A2A1, the Digital Expansion Assembly (Options) A2A1 must be removed for access to the A2U5 component.

NOTE: Observe proper Electro Static Discharge (ESD) procedures when removing and replacing A2U5.

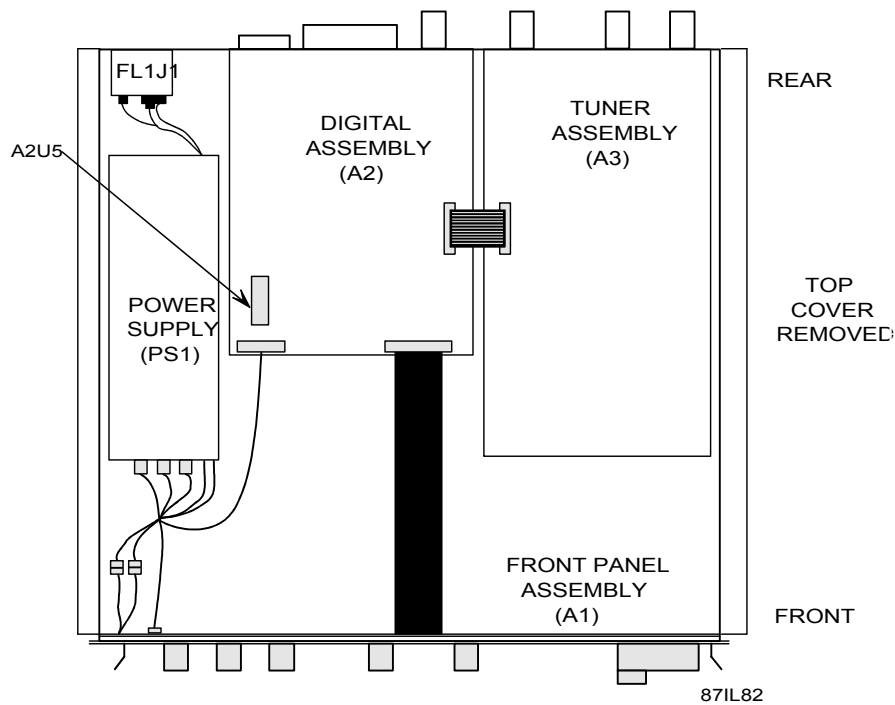

Figure 7-23. RAM/ BATTERY (U5) Removal and Replacement Procedures

SECTION 8

REPLACEMENT PARTS LIST

THIS PAGE INTENTIONALLY LEFT BLANK

SECTION 8

REPLACEMENT PARTS LIST

8.1 UNIT NUMBERING METHOD

The method of numbering used throughout the unit is assigning reference designations (electrical symbol numbers) to identify: assemblies, subassemblies, modules within a subassembly, and discrete components. An example of the unit numbering method used is as follows:

Subassembly Designation A1	R1 Class and No. of Item
Identify from right to left as:	First (1) resistor (R) of first (1) subassembly (A)

On the main chassis schematic, components which are an integral part of the main chassis have no subassembly designations.

8.2 REFERENCE DESIGNATION PREFIX

The use of partial reference designations are used on the equipment and on the manual illustrations. This partial reference designation consists of the component type letter(s) and the identifying component number. The complete reference designation may be obtained by placing the proper prefix before the partial reference designation. Reference designation prefixes are included on the drawings and illustrations in the figure titles (in parenthesis).

8.3 PROVISIONING NOTE - INCONSISTENCIES IN PART NUMBERING CONVENTIONS

The internal computer applications at DRS Signal Solutions, Inc. have undergone upgrades to better serve our customers. With this upgrade came alterations to the numbering scheme for parts reporting to an end item. Due to these alterations, minor inconsistencies may exist between identifying parts numbers found on drawings, piece parts, or other documentation. No form fit and function specifications have been altered due to this change in the numbering scheme.

The inconsistencies take two forms. New part number conventions mandate the use of three-digit suffixes for part numbers used within computer applications. Part numbers having single-digit suffixes have been altered by the addition of leading zeroes. Therefore, a piece part with an identifying number having a suffix of "-2" may be represented in a computer-generated document with a part number having a suffix of "-002". Also the new part numbering convention requires that the base portion of a part number be made up of six digits. Part numbers with base portions with less than six digits are expressed with leading zeroes to meet this requirement. Accordingly, a part number having a base of "34456" may appear as "034456". If you have questions or concerns regarding the configuration identification of piece parts, contact the plant for additional information at 1-800-954-3577.

8.4 LIST OF MANUFACTURERS

<u>Mfr. Code</u>	<u>Name and Address</u>	<u>Mfr. Code</u>	<u>Name and Address</u>
0B0A9	Dallas Semiconductor Corp. 4350 Beltwood Parkway S Dallas, TX 75244	06665	Precision Monolithics, Inc. 1500 Space Park Drive Santa Clara, CA 95050
0G546	Motorola Corp. Schaumburg, IL 60159	1Z447	RCA Corp. Solid State Div. 2872 Woodcock Blvd. Suite 304 Atlanta, GA 30341
0H857	Analog Devices 2105 S. Bascom Ave, Suite 325 Campbell, CA 95008	12697	Clarostat Mfg. Co., Inc. 1 Washington P.O. Box 1507 Dover, NH 03820-1507
0J948	Kemet Electronics Corp. 6345 Balboa Blvd., Suite 335 Encino, CA 91316	14632	DRS Signal Solutions, Inc. 700 Quince Orchard Road Gaithersburg, MD 20878
0VUE0	Raltron Electronics Corp. 2315 N.W. 107th Avenue Miami, FL 33172	14778	Renco Electronics Incorporated 60 Jefryn Blvd., E Deer Park, NY 11729
00779	AMP, Inc. P. O. Box 3608 Harrisburg, PA 17150	15542	Mini-Circuits Laboratories 2625 E. 14th Street Brooklyn, NY 11235
01295	Texas Instruments, Inc. 13500 No. Central Express Way Dallas, TX 75231	17826	Techno Components Corp. 4051 Greystone Drive Ontario, CA 91761
03508	General Electric Company Semi-Conductor Products Dept. W. Genesee Street Auburn, NY 13021	17856	Siliconix Incorporated 2201 Laurelwood Road Santa Clara, CA 95050
03550	Vanguard Electronics Co. 7412 Prince Drive Huntington Beach, CA 92647	18324	Signetics Corporation 4130 So. Market Court Sacramento, CA 94834
04222	AVX Corp. 801 17th Ave S. Myrtle Beach, SC 29578	19112	Wirepro Inc. 90 West Broadway Salem, NJ 08079
04713	Motorola, Inc. 5005 East McDowell Road Phoenix, AZ 85008	20462	Prem Magnetics Incorporated 3521 No. Chapel Hill Road McHenry, IL 60050
05245	CO RCOM, Inc. 1600 Winchester Road Libertyville, IL 60048-1267	22526	Dupont Electronics Department Route 83 New Cumberland, PA 17070

WJ-8711A DIGITAL HF RECEIVER

<u>Mfr.</u>	<u>Name and Address</u>	<u>Mfr.</u>	<u>Name and Address</u>
<u>Code</u>		<u>Code</u>	
24355	Analog Devices Incorporated Route 1, Industrial Park P.O. Box 280 Norwood, MA 02062	52648	Plessey Semiconductors 1641 Kaiser Avenue Irvine, CA 92714
24931	Specialty Connector Co., Inc. 2100 Earlywood Drive P.O. Box 547 Franklin, TN 46131	53337	RDI REED Devices, Inc. Subsidiary of AUGAT Inc. 525 Randy Road Carol Stream, IL 60188
25088	Siemens America Incorporated 186 Wood Avenue So. Iselin, NJ 08830	54473	Panasonic Industrial Company One Panasonic Way P.O. Box 1501 Secaucus, NJ 07094
26742	Methode Electronics Inc. 7447 W. Wilson Avenue Chicago, IL 60658-4548	54483	Aircraft Systems Corporation West Caldwell, NJ
27014	National Semi-Conductor Corp. 2950 San Ysidro Way Santa Clara, CA 95051	54583	TDK Electronics Corporation 12 Harbor Park Drive Port Washington, NJ 11550
27264	Molex Incorporated 2222 Wellington Court Lisle, IL 60532	55322	Samtec Incorporated 810 Progress Boulevard P.O. Box 1147 New Albany, IN 47150
28480	Hewlett-Packard Company 1501 Page Mill Road Palo Alto, CA 94304	56289	Sprague Electric Co. World Hqs. 267 Lowell Road Hudson, NH 03051-4900
30149	Standard Crystal Corporation 9940 E. Baldwin Place El Monte, CA 91731	58982	Precision Connector Designs, Inc. Centennial Park 2 Technology Drive Peabody, MA 01960
31433	Kemet Electronics Corp 2835 Kemet Way Simpsonville, SC 29681	6E390	Powell Electronics, Inc. 2260 Lundy Avenue San Jose, Ca 95131-1816
34371	Harris Corp. Semiconductor Sector 200 Palm Bay Boulevard P.O. Box 883 Melbourne, FL 32902-0883	6Y440	Micron Semiconductor, Inc. 2805 E. Columbia Road Boise, ID 83706-9698
4W716	Specialty Electric Inc. Airport Way Hailey, ID 83333	61271	Fujitsu Microelectronics, Inc. 2985 Kifer Road Santa Clara, CA 95051-0802
51406	Murata Erie North America, Inc. 1148 Franklin Road, S.E. Marietta, GA 30067	61638	Advanced Interconnections Corp. 5 Division Street West Warwick, RI 02818-3842

<u>Mfr.</u> <u>Code</u>	<u>Name and Address</u>	<u>Mfr.</u> <u>Code</u>	<u>Name and Address</u>
62786	Hitachi America, LTD. 1800 Bering Drive San Jose, CA 95122	81640	EATON Corporation Aerospace and Commercial 2250 Whitfield Avenue E. Sarasota, FL 34243-9703
65238	Nova Cap Corp. 25136 Anza Drive Valencia, CA 91355	86797	Rogan Corporation 3455 Woodhead Drive Northbrook, IL 60062-1812
7J069	TDK Corporation of America 4015 W Vincennes Road Indianapolis, IN 46268-3008	9AA37	JST Corporation 1200 Business Center Drive Mt. Prospect, IL 60056
71400	Bussmann Div. Of Cooper Industries, Inc. 114 Old State Road Ellisville, MO 63021	9AA39	TO KO America, Inc. Eastern Regional Office 107 Mill Plain Road Danbury, CT 06811
72982	Erie Speciality Products, Inc. 645 W. 11th Street Erie, PA 16501	95146	Alco Electronics Products, Inc. 1551 Osgood Street North Andover, MA 01845
75915	Littlefuse Tracor, Inc. Subsidiary of Tracor, Inc. 800 E. Northwest Highway Des Plaines, IL 60016-3049	95275	Vitramon, Inc. Box 544 Bridgeport, CT 06601-0544
8J671	Crane Component, Co. 4000 Rane Centre Drive Streetsboro, OH 44240-5076	99800	Delivan Electronics Division 270 Quaker Road East Aurora, NY 14052-2114
8Z573	JS Terminal Corp. of America 1380 Brummel Avenue Elk Grove Village, IL 60007-2109	TBD1	Vendor: Venkel Corp. Vendor ID: ID 6062
80294	Bourns Incorporated 6135 Magnolia Avenue Riverside, CA 92506	TBD2	Vendor: Arrow Electronics Inc. Vendor ID: 3538
81349	Military Specifications Promulgated by Military		

8.5 PARTS LIST

The following parts list contains all the electrical components used in the unit, along with mechanical parts which may be subject to unusual wear or damage. When ordering replacement parts from the factory specify the unit type and the serial number, and the option configuration. Also include the reference designation and description for each item ordered. The list of

manufacturers, provided in **paragraph 8.4**, and the manufacturer's part number, provided in **paragraph 8.6**, are supplied as a guide to aid the user of the equipment while in the field. The parts listed may not necessarily be identical with the parts installed in the unit. The parts listed in **paragraph 8.6** will provide for satisfactory unit operation.

Replacement parts may be obtained from any manufacture provided that the physical characteristics and electrical parameters of the replacement item are compatible with the original part. In the case where components are identified by a military or industrial specification, a vendor which can provide the necessary component is suggested as a convenience to the user.

NOTE: As improved semiconductors become available, it is the policy of the factory to incorporate them in proprietary products. For this reason some transistors, diodes and integrated circuits installed in the equipment may not agree with those specified in the parts list and schematic diagrams of this manual. However, the semiconductors designated in the manual may be substituted in every case with satisfactory results.

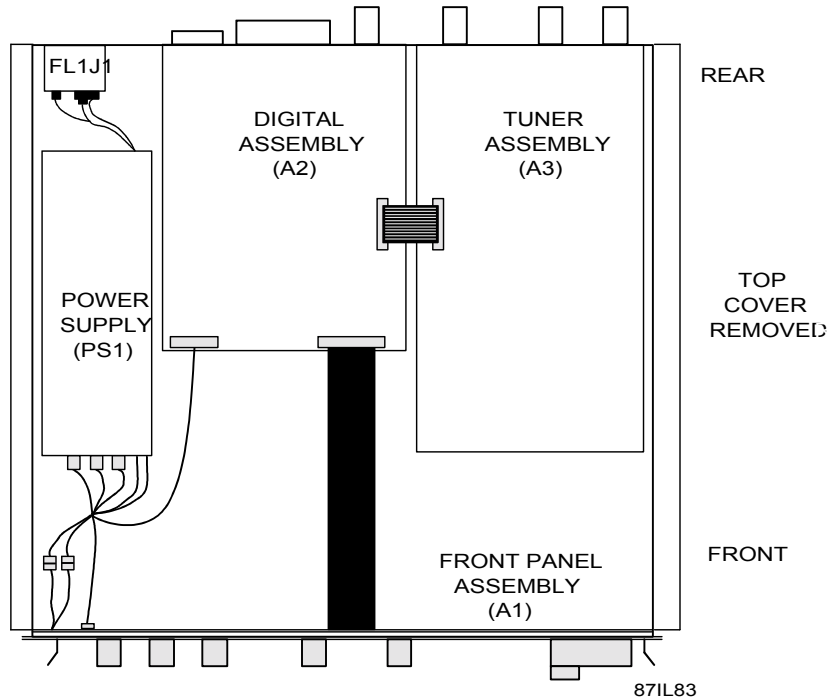

Figure 8-1. WJ-8711A Main Chassis Component Locations

WJ-8711A DIGITAL HF RECEIVER

<i>REF DESIG</i>	<i>DESCRIPTION</i>	<i>QTY PER ASSY</i>	<i>MANUFACTURERS PART NO.</i>	<i>MFR. CODE</i>	<i>RECM VENDOR</i>
----------------------	--------------------	-----------------------------	-----------------------------------	----------------------	------------------------

8.6 TYPE WJ-8711A DIGITAL HF RECEIVER

MAIN CHASSIS

	Revision JI				
A1	Front Panel Assembly	1	797015-1	14632	
A1A1	Front Panel PC Assembly	1	482108-1	14632	
A1J1	Jack Assembly, Phone	1	382887-1	14632	
A1RV1	Varistor, 275 VAC RMS	1	V275IA4	03508	
A1S1	Switch, Rocker, Power	1	DM24-J72-S2-05-Q-6	O CY71	
A2	Digital Control PC Assembly (Standard)	0-1	797214-1	14632	
	or				
A2	Digital Control PC Assembly (Standard)	0-1	904978-1	14632	
A3	RF Tuner Assembly (.7 PPM Stability) (Standard)	1	797006-1	14632	
FL1J1	Filter/ Power	1	FN365-2/05	0KDK8	
PS1	Power Supply Assembly	1	180872-1	14632	
W1	Cable Assembly	1	382892-1	14632	

<i>REF DESIG</i>	<i>DESCRIPTION</i>	<i>QTY PER ASSY</i>	<i>MANUFACTURERS PART NO.</i>	<i>MFR. CODE</i>	<i>RECM VENDOR</i>
----------------------	--------------------	-----------------------------	-----------------------------------	----------------------	------------------------

8.6.1 TYPE 482108-1 FRONT PANEL PC ASSEMBLY

REF DESIG PREFIX A1A1

	Revision H1				
C1	Capacitor, Ceramic, Axial: .1 μ F, 50 V, Z5U, \pm 20%	30	SL105E104MAA	51406	
C2					
Thru					
C9					
C10	Capacitor, Ceramic, Axial: .01 μ , 50 V, Z5U, \pm 20%	4	SL105E103MAA	51406	
C11					
Thru	Same as C10				
C13					
C14	Capacitor, Electrolytic, Aluminum: 470 μ F, 16 V	2	ECEACU471	54473	
C15	Same as C14				
C16					
Thru	Same as C1				
C36					
CR1	Diode	8	1N4449	80131	
CR2					
Thru	Same as CR1				
CR8					
DS1	Display	9	HDIG-2416	28480	
DS2					
Thru	Same as DS1				
DS9					
DS10	Display	8	MAN6480	58361	
DS11					
Thru	Same as DS10				
DS17					
DS18	LED, Lamp	1	HIMP-1503	28480	
DS19	LED, Lamp	9	HIMP-S500	28480	
DS20					
Thru	Same as DS19				
DS27					
DS28	Lamp	1	86	55335	
DS29	Not Installed				
E7	Cable Assembly	1	IDMD-12-T9-C-R	55322	
J1	Connector, Header, 3 Position, Straight Pin, Friction Lock	1	26-48-2035	27264	
J2	Not Installed				
J3	Connector, Plug, 3 Pin, Straight Post Header	2	640456-3	00779	
J4	Same as J3				
L1	Inductor: 150: μ H, Power Line Choke, DCR = .24 Ω	1	RL1284-150	14778	
M1	Meter	1	841710	14632	
QN1	Transistor Array	3	MPQ2907	04713	
QN2	Same as QN1				
QN3	Same as QN1				

WJ-8711A DIGITAL HF RECEIVER

REF DESIG	DESCRIPTION	QTY PER ASSY	MANUFACTURERS PART NO.	MFR. CODE	REC'D VENDOR
REF DESIG PREFIX A1A1					
R1	Resistor, Fixed, Film: 10 k Ω , 5%, 1/8 W	9	CF1/8-10K/J	59124	
R2					
Thru	Same as R1				
R4					
R5	Resistor, Fixed, Film: 1.0 k Ω , 5%, 1/8 W	2	CF1/8-1.0K/J	59124	
R6	Same as R1				
R7	Resistor, Variable: 10 k Ω , CW Linear, CP \pm 10%	2	PCW1D-C24-BAB-103	80294	
R8	Resistor, Fixed, Film: 22 Ω , 5%, 1/8 W	16	CF1/8-22 OHMS/J	59124	
R9					
Thru	Same as R8				
R11					
R12	Resistor, Fixed, Film: 2.2 k Ω , 5%, 1/8 W	12	CF1/8-2.2K/J	59124	
R13					
Thru	Same as R12				
R23					
R24					
Thru	Same as R8				
R31					
R32	Resistor, Fixed, Film: 33 k Ω , 5%, 1/8 W	1	CF1/8-33K/J	59124	
R33	Resistor, Fixed, Film: 100 k Ω , 5%, 1/8 W	8	CF1/8-100K/J	59124	
R34	Same as R5				
R35					
Thru	Same as R1				
R38					
R39	Same as R7				
R40	Resistor, Variable: 10 k Ω , CW Audio, CP \pm 10%	1	PCW1D-C24-BAD-103	80294	
R41					
Thru	Same as R8				
R44					
R45					
Thru	Same as R33				
R51					
R52	Resistor, Fixed, Film: 6.8 Ω , 5%, 1/4 W	1	CF1/4-6.8 OHMS/J	59124	
R53	Not In Circuit				
R54	Resistor, Fixed, Film: 150 Ω , 5%, 1/8 W	1	CF1/8-150 OHMS/J	59124	
S1	Switch, Subminiature, PCB MTG, w/ Green IED	17	TR2-21-15	8S746	
S2	Same as S1				
S3	Same as S1				
S5	Switch, Subminiature, Rubber Contact, PCB Mtg	27	TR1-01	18022	
S6	Same as S5				
S7					
Thru	Same as S1				
S10					

REF DESIG	DESCRIPTION	QTY PER ASSY	MANUFACTURERS PART NO.	MFR. CODE	RECM VENDOR
--------------	-------------	--------------------	---------------------------	--------------	----------------

REF DESIG PREFIX A1A1

S14	Same as S5				
S15	Same as S1				
S16	Same as S1				
S17	Same as S5				
S18	Same as S1				
S19	Same as S5				
S20	Same as S1				
S21	Same as S5				
S22	Same as S5				
S23	Same as S1				
S24					
Thru	Same as S5				
S28					
S29	Same as S1				
S30					
Thru	Same as S5				
S38					
S39					
Thru	Same as S1				
S41					
S42	Same as S5				
S43	Same as S5				
S44	Same as S1				
S45					
Thru	Same as S5				
S48					
U1	Integrated Circuit, MCU: 16-Bit Timer, 8 Channel, 8-Bit A/ D Conv, 48-pin Dip	1	MC68HC11A0P	04713	
U2	Integrated Circuit, Octal, D-Type Latch, 20 Pin Dip	2	MM74HC573N	27014	
U3	EPROM, Programmed	1	841676	14632	
U4	Integrated Circuit, CMOS, Quad 2-Input, Nand Gate	1	MM74HC00N	27014	
U5	Integrated Circuit, Buffer, CMOS, Hex Buffer, Ninv	2	MM74HC365N	27014	
U6	Integrated Circuit, CMOS, 3-to-8 IN DCDR/ DMUX	2	MM74HG138N	27014	
U7	Same as U6				
U8	Same as U2				
U9	Integrated Circuit, Hex, D-Type Flip-Flop, 16 Pin Dip	1	MM74HC174N	27014	
U10	Integrated Circuit/ CMOS, Octal, Dual Flip-Flop, 20 Pin Dip	2	MM74HC273N	27014	
U11	Same as U10				
U12	Integrated Circuit, 1.5Z, Darlington Arrays, Quad Drivers 16 Pin Dip	2	UIN2068B	56289	
U13	Same as U12				
U14	Integrated Circuit, CMOS, Dual, Retriggerable, Monostable Multivibrator	1	MM74HF123AN	27014	

WJ-8711A DIGITAL HF RECEIVER

<i>REF DESIG</i>	<i>DESCRIPTION</i>	<i>QTY PER ASSY</i>	<i>MANUFACTURERS PART NO.</i>	<i>MFR. CODE</i>	<i>RECM VENDOR</i>
----------------------	--------------------	-----------------------------	-----------------------------------	----------------------	------------------------

REF DESIG PREFIX A1A1

U15	Integrated Circuit, BUF, CMOS, HS Hex Schmt, Inv	1	MM74HC14N	27014	
U16	Integrated Circuit, CMOS, Dual D-FF	2	MM74HC74N	27014	
U17	Same as U16				
U18	Same as U5				
U19	Integrated Circuit, Asynchronous, 7-Bit Binary Counters 14 Pin Dip	1	SN74HC4024N	01295	
U20	Encoder	2	ECT1D-C24-GC0024	80294	
U21	Same as U20				
U22	Encoder, Miniature Panel Mt, Optical Encoder	1	HRPG-A-SCA-19F	28480	
XU3	Socket, Integrated Circuit, 28 Pin	1	ICO-628-SGT	55322	

<i>REF DESIG</i>	<i>DESCRIPTION</i>	<i>QTY PER ASSY</i>	<i>MANUFACTURERS PART NO.</i>	<i>MFR. CODE</i>	<i>RECM VENDOR</i>
----------------------	--------------------	-----------------------------	-----------------------------------	----------------------	------------------------

8.6.2A TYPE 797214-1 DIGITAL CONTROL PC ASSEMBLY

REF DESIG PREFIX A2

	Revision A				
BT1	Not Used				
XBT1	Not Used				
BT2	Not Used				
XBT2	Not Used				
C1	Capacitor, Ceramic, .01μF, 10%	118	841415-019		14632
C2	Same as C1				
C3	Same as C1				
C4	Capacitor, Ceramic, .033μF, 10%	17	841415-022		14632
C5	Same as C4				
C6	Same as C4				
C7	Same as C4				
C8	Same as C4				
C9	Same as C4				
C10	Same as C4				
C11	Same as C1				
C12	Capacitor, Ceramic, .1μF, 10%, >/ =50VDC	8	841250-25		14632
C13	Same as C1				
C14	Capacitor, Ceramic, 75pF, ~-2%	1	841416-046		14632
C15	Capacitor, Tantalum, 3.3μF, 20%, 16V	10	841293-10		14632
C16	Same as C12				
C17	Capacitor, Ceramic, 22pF, 5%	3	841415-003		14632
C18	Same as C1				
C19	Same as C1				
C20	Capacitor, Ceramic, 100pF, 5%	9	841415-007		14632
C21	Same as C20				
C22	Same as C20				
C23	Same as C20				
C24	Same as C1				
C25	Capacitor, Electrolytic, Aluminum, 470 F, 16V	1	ECEA1CU471		54473
C26	Same as C1				
C27	Capacitor, Ceramic, .047μF, 10%	9	841415-023		14632
C28	Same as C27				
C29	Same as C1				
C30	Same as C4				
C31	Same as C4				
C32	Same as C1				
C33	Same as C4				
C34	Same as C1				
C35	Same as C15				
C36	Same as C1				
C37	Same as C1				
C38	Same as C12				

WJ-8711A DIGITAL HF RECEIVER

<i>REF DESIG</i>	<i>DESCRIPTION</i>	<i>QTY PER ASSY</i>	<i>MANUFACTURERS PART NO.</i>	<i>MFR. CODE</i>	<i>RECM VENDOR</i>
----------------------	--------------------	-----------------------------	-----------------------------------	----------------------	------------------------

REF DESIG PREFIX A2

C39	Same as C1				
C40	Capacitor, Tantalum, 10µF, 20%, 16V	2	841293-16		14632
C41	Same as C17				
C42	Same as C17				
C43	Same as C12				
C44	Same as C1				
C45	Same as C12				
C46	Same as C40				
C47	Same as C1				
C48	Same as C12				
C49	Capacitor, Ceramic, 470pF, 5%	8	841415-011		14632
C50	Same as C49				
C51	Same as C49				
C52	Same as C49				
C53	Same as C49				
C54	Same as C1				
C55	Same as C1				
C56	Capacitor, Ceramic, 1000pF, 10%	4	841415-013		14632
C57	Capacitor, Ceramic, 47pF, 2%	4	841416-041		14632
C58	Same as C1				
C59	Same as C1				
C60	Same as C1				
C61	Same as C15				
C62	Same as C15				
C63	Same as C15				
C64	Same as C1				
C65	Same as C1				
C66	Same as C1				
C67	Same as C1				
C68	Same as C1				
C69	Same as C1				
C70	Same as C1				
C71	Same as C15				
C72	Same as C56				
C73	Same as C56				
C74	Same as C49				
C75	Same as C27				
C76	Same as C27				
C77	Capacitor, Ceramic, 1500pF, 10%,	3	841415-014		14632
C78	Same as C27				
C79	Same as C77				
C80	Same as C77				
C81	Capacitor, Ceramic, 820pF, ~-2%	3	841416-071		14632

REF DESIG	DESCRIPTION	QTY PER ASSY	MANUFACTURERS PART NO.	MFR. CODE	RECM VENDOR
--------------	-------------	--------------------	---------------------------	--------------	----------------

REF DESIG PREFIX A2

C82	Same as C49				
C83	Same as C1				
C84	Same as C1				
C85	Same as C1				
C86	Same as C49				
C87	Same as C1				
C88	Same as C1				
C89	Same as C1				
C90	Same as C1				
C91	Same as C1				
C92	Same as C1				
C93	Same as C1				
C94	Same as C1				
C95	Same as C1				
C96	Capacitor, Ceramic, 2200pF, 10%	4	841415-015	14632	
C97	Same as C57				
C98	Same as C1				
C99	Same as C1				
C100	Same as C1				
C101	Same as C27				
C102	Same as C1				
C103	Same as C15				
C104	Same as C15				
C105	Same as C4				
C106	Capacitor, Ceramic, 220pF, 5%	1	841415-009	14632	
C107	Same as C1				
C108	Same as C27				
C109	Same as C1				
C110	Same as C1				
C111	Same as C1				
C112	Same as C15				
C113	Capacitor, Ceramic, 330pF, 5%	1	841415-010	14632	
C114	Same as C27				
C115	Same as C57				
C116	Same as C1				
C117	Same as C1				
C118	Same as C96				
C119	Same as C1				
C120	Same as C1				
C121	Same as C15				
C122	Same as C57				
C123	Same as C4				
C124	Same as C96				

WJ-8711A DIGITAL HF RECEIVER

<i>REF DESIG</i>	<i>DESCRIPTION</i>	<i>QTY PER ASSY</i>	<i>MANUFACTURERS PART NO.</i>	<i>MFR. CODE</i>	<i>RECM VENDOR</i>
----------------------	--------------------	-----------------------------	-----------------------------------	----------------------	------------------------

REF DESIG PREFIX A2

C125	Capacitor, Ceramic, 180pF, 2%	1	841416-055	14632	
C126	Capacitor, Ceramic, 470pF, 2%	1	841416-065	14632	
C127	Same as C27				
C128	Capacitor, Ceramic, 68pF, ~2%	1	841416-045	14632	
C129	Same as C1				
C130	Same as C1				
C131	Not Used				
C132	Same as C1				
C133	Same as C1				
C134	Same as C1				
C135	Not Used				
C136	Same as C1				
C137	Same as C1				
C138	Same as C81				
C139	Same as C1				
C140	Same as C1				
C141	Same as C1				
C142	Not Used				
C143	Same as C1				
C144	Same as C81				
C145	Same as C1				
C146	Same as C1				
C147	Same as C1				
C148	Capacitor, Ceramic, 100pF, 2%	4	841416-049	14632	
C149	Same as C148				
C150	Same as C148				
C151	Same as C148				
C152	Same as C1				
C153	Same as C1				
C154	Same as C1				
C155	Same as C1				
C156	Same as C1				
C157	Same as C1				
C158	Capacitor, Ceramic, 1000pF, 2%	1	841416-073	14632	
C159	Capacitor, Ceramic, 56pF, 2%	1	841416-043	14632	
C160	Same as C1				
C161	Same as C1				
C162	Capacitor, Ceramic, 1200pF, 2%	1	841416-075	14632	
C163	Capacitor, Tantalum, 68µF, 20%, 6.3V	1	841293-24	14632	
C164	Same as C1				
C165	Same as C1				
C166	Same as C1				
C167	Same as C1				

<i>REF DESIG</i>	<i>DESCRIPTION</i>	<i>QTY PER ASSY</i>	<i>MANUFACTURERS PART NO.</i>	<i>MFR. CODE</i>	<i>RECM VENDOR</i>
----------------------	--------------------	-----------------------------	-----------------------------------	----------------------	------------------------

REF DESIG PREFIX A2

C168	Same as C1				
C169	Same as C1				
C170	Same as C1				
C171	Same as C56				
C172	Same as C1				
C173	Same as C1				
C174	Same as C1				
C175	Capacitor, Tantalum, 33 μ F, 20%, 16V	9	841293-22	14632	
C176	Same as C175				
C177	Same as C96				
C178	Same as C1				
C179	Same as C175				
C180	Capacitor, Tantalum, 6.8 μ F, 20%, 6.3V	2	841293-14	14632	
C181	Same as C180				
C182	Same as C1				
C183	Not Used				
C184	Same as C1				
C185	Same as C12				
C186	Same as C12				
C187	Same as C1				
C188	Same as C1				
C189	Same as C1				
C190	Not Used				
C191	Same as C1				
C192	Same as C4				
C193	Same as C1				
C194	Same as C1				
C195	Same as C1				
C196	Same as C1				
C197	Same as C1				
C198	Not Used				
C199	Not Used				
C200	Same as C1				
C201	Same as C1				
C202	Same as C175				
C203	Same as C175				
C204	Same as C175				
C205	Same as C1				
C206	Same as C20				
C207	Same as C1				
C208	Same as C1				
C209	Same as C1				
C210	Same as C1				

WJ-8711A DIGITAL HF RECEIVER

<i>REF DESIG</i>	<i>DESCRIPTION</i>	<i>QTY PER ASSY</i>	<i>MANUFACTURERS PART NO.</i>	<i>MFR. CODE</i>	<i>RECM VENDOR</i>
----------------------	--------------------	-----------------------------	-----------------------------------	----------------------	------------------------

REF DESIG PREFIX A2

C211	Same as C1				
C212	Same as C1				
C213	Same as C1				
C214	Same as C20				
C215	Same as C20				
C216	Same as C1				
C217	Same as C20				
C218	Same as C1				
C219	Same as C175				
C220	Same as C175				
C221	Same as C175				
C222	Same as C1				
C223	Same as C20				
C224	Same as C1				
C225	Same as C1				
C226	Same as C1				
C227	Same as C1				
C228	Same as C1				
C229	Same as C4				
C230	Same as C1				
C231	Same as C1				
C232	Not Used				
C233	Same as C4				
C234	Not Used				
C235	Same as C1				
C236	Same as C4				
C237	Same as C4				
C238	Not Used				
C239	Not Used				
CR1	Not Used (SOT23)				
CR2	Diode/ Swpin Dual Switching Diode Reverse Voltage	2	MMBD7000LT1	04713	
CR3	Not Used				
CR4	Same as CR2				
CR5	Not Used				
FL1	Filter, 455 kHz Precision Ladder Type	1	CFS-455B	51406	
J1	Connector, Jack, BNC BNC Rt Ang , PCB/ Panel MT W/ SIDR Mt Posts	1	227677-1	00779	
J2	Phone Jack, 3.5 Dia Mini Phone Jack, RES=30M	1	SB60	53337	
J3	Connector, 25-Pin D-Sub RT Ang, PC MT	1	DMRSTR25RA05CG	05574	
J4	CONN 24-Pin Term Strip Gold Flash .100CTRS	4	79223-624	22526	
J5	Connector, Header,6 Pos Pin Friction Lock .156 CTRS	1	26-48-2066	27264	
J6	Not Used				
J7	Same as J4				

REF DESIG	DESCRIPTION	QTY PER ASSY	MANUFACTURERS PART NO.	MFR. CODE	RECM VENDOR
--------------	-------------	--------------------	---------------------------	--------------	----------------

REF DESIG PREFIX A2

J8	Same as J4				
J9	Same as J4				
J10	Not Used				
J11	Connector, PC, BD 3 Pin SHRD HDR	1	3-102202-4	00779	
J12	Not Used				
J13	Not Used				
J14	Connector, Header, 10 Pin HDR .025SQ X.230 X.10CTR SGID PLID	1	TSW 105-07-G-D	55322	
J15	Not Used				
J16	Not Used				
JW 1	Not Used				
L1	Inductor, 10µH, Surface MT	3	RL1500-10	14778	
L2	Same as L1				
L3	Same as L1				
L4	Inductor, 1.0µH, ~-20%,@7.96MHZ Q MIN-25 370MA Ferrite 1210	9	B82422-A1102-M	25088	
L5	Same as L4				
L6	Same as L4				
L7	Same as L4				
L8	Same as L4				
L9	Same as L4				
L10	Same as L4				
L11	Not Used				
L12	Inductor, 2.2µH	1	841444-009	14632	
L13	Inductor, 4.7µH	1	B82422-A1472-M	25088	
L14	Inductor, 150nH	1	841438-029	14632	
L15	Inductor, 68nH	1	841438-021	14632	
L16	Inductor, 2.7µH	1	841444-011	14632	
L17	Not Used				
L18	Inductor, 1000µH	2	NIF453232-102K	7J069	
L19	Same as L18				
L20	Same as L4				
L21	Same as L4				
L22	Not Used				
L23	Not Used				
Q1	Not Used				
Q2	Transistor	3	MMBT2222ALT1	04713	
Q3	Same as Q2				
Q4	Not Used				
Q5	Not Used				
Q6	Transistor	2	2N7002-IT1	17856	
Q7	Same as Q2				
Q8	Transistor	2	MMBT3906	04713	

WJ-8711A DIGITAL HF RECEIVER

<i>REF DESIG</i>	<i>DESCRIPTION</i>	<i>QTY PER ASSY</i>	<i>MANUFACTURERS PART NO.</i>	<i>MFR. CODE</i>	<i>RECM VENDOR</i>
REF DESIG PREFIX A2					
Q 9	Same as Q 6				
Q 10	Transistor	2	MMBT3904LT1	04713	
Q 11	Same as Q 8				
Q 12	Same as Q 10				
R1	Resistor, Fixed, 100k Ω , 5%	110	841414-121	14632	
R2	Resistor, Fixed, 47 Ω , 5%	20	841414-041	14632	
R3	Resistor, Fixed, 47k Ω , 5%	7	841414-113	14632	
R4	Same as R3				
R5	Resistor, Fixed, 100 Ω , 5%	16	841414-049	14632	
R6	Same as R3				
R7	Resistor, Fixed, 10k Ω , 5%	43	841414-097	14632	
R8	Resistor, Fixed, 4.7k Ω , 5%	7	841414-089	14632	
R9	Resistor, Fixed, 2.2k Ω , 5%	8	841414-081	14632	
R10	Same as R2				
R11	Resistor, Fixed, 820 Ω , 5%	1	841414-071	14632	
R12	Resistor, Fixed, 680 Ω , 5%	1	841414-069	14632	
R13	Same as R5				
R14	Same as R5				
R15	Not Used				
R16	Not Used				
R17	Not Used				
R18	Resistor, Fixed, 1.0k Ω , 5%	23	841414-073	14632	
R19	Jumper .05 Ω MAX 1A MIN@70C	26	841417	14632	
R20	Same as R19				
R21	Same as R18				
R22	Same as R19				
R23	Not Used				
R24	Same as R18				
R25	Same as R19				
R26	Resistor, Fixed, 1.5k Ω , 5%	5	841414-077	14632	
R27	Same as R19				
R28	Same as R18				
R29	Resistor, Fixed, 2.7 Ω , 5%	4	841414-011	14632	
R30	Resistor, Fixed, 22k Ω , 5%	4	841414-105	14632	
R31	Same as R5				
R32	Same as R30				
R33	Same as R5				
R34	Same as R1				
R35	Same as R19				
R36	Resistor, Fixed, 2.7k Ω , 5%	2	841414-083	14632	
R37	Same as R18				
R38	Same as R19				
R39	Same as R7				

<i>REF DESIG</i>	<i>DESCRIPTION</i>	<i>QTY PER ASSY</i>	<i>MANUFACTURERS PART NO.</i>	<i>MFR. CODE</i>	<i>RECM VENDOR</i>
----------------------	--------------------	-----------------------------	-----------------------------------	----------------------	------------------------

REF DESIG PREFIX A2

R40	Same as R7				
R41	Same as R18				
R42	Same as R7				
R43	Same as R19				
R44	Not Used				
R45	Same as R18				
R46	Same as R36				
R47	Same as R2				
R48	Same as R1				
R49	Same as R1				
R50	Resistor, Fixed, 470Ω, 5%	10	841414-065	14632	
R51	Not Used				
R52	Resistor, Fixed, 75kΩ, 5%	2	841414-118	14632	
R53	Same as R52				
R54	Same as R1				
R55	Resistor, Fixed, 33kΩ, 5%	5	841414-109	14632	
R56	Resistor, Fixed, 220kΩ, 5%	6	841414-129	14632	
R57	Same as R55				
R58	Same as R56				
R59	Resistor, Fixed, 68kΩ, 5%	4	841414-117	14632	
R60	Same as R18				
R61	Same as R1				
R62	Same as R1				
R63	Same as R50				
R64	Same as R1				
R65	Same as R1				
R66	Same as R1				
R67	Same as R2				
R68	Same as R56				
R69	Same as R56				
R70	Same as R2				
R71	Same as R56				
R72	Same as R56				
R73	Same as R2				
R74	Same as R59				
R75	Same as R18				
R76	Same as R1				
R77	Same as R1				
R78	Same as R9				
R79	Same as R1				
R80	Same as R1				
R81	Same as R18				
R82	Same as R1				

WJ-8711A DIGITAL HF RECEIVER

<i>REF DESIG</i>	<i>DESCRIPTION</i>	<i>QTY PER ASSY</i>	<i>MANUFACTURERS PART NO.</i>	<i>MFR. CODE</i>	<i>RECM VENDOR</i>
----------------------	--------------------	-----------------------------	-----------------------------------	----------------------	------------------------

REF DESIG PREFIX A2

R83	Same as R1				
R84	Same as R1				
R85	Not Used				
R86	Same as R1				
R87	Same as R2				
R88	Same as R18				
R89	Same as R9				
R90	Same as R1				
R91	Same as R1				
R92	Same as R1				
R93	Same as R50				
R94	Resistor, Fixed, 18kΩ, 5 %	4	841414-103	14632	
R95	Same as R2				
R96	Same as R94				
R97	Same as R2				
R98	Same as R3				
R99	Same as R3				
R100	Same as R55				
R101	Same as R8				
R102	Same as R1				
R103	Same as R1				
R104	Same as R1				
R105	Not Used				
R106	Same as R9				
R107	Same as R94				
R108	Same as R9				
R109	Same as R94				
R110	Same as R18				
R111	Same as R7				
R112	Resistor, Fixed, 8.2kΩ, 5 %	2	841414-095	14632	
R113	Same as R112				
R114	Same as R7				
R115	Same as R1				
R116	Not Used				
R117	Same as R7				
R118	Same as R7				
R119	Same as R7				
R120	Same as R1				
R121	Same as R1				
R122	Same as R1				
R123	Same as R1				
R124	Same as R2				
R125	Same as R1				

<i>REF DESIG</i>	<i>DESCRIPTION</i>	<i>QTY PER ASSY</i>	<i>MANUFACTURERS PART NO.</i>	<i>MFR. CODE</i>	<i>RECM VENDOR</i>
----------------------	--------------------	-----------------------------	-----------------------------------	----------------------	------------------------

REF DESIG PREFIX A2

R126	Same as R18				
R127	Same as R59				
R128	Same as R7				
R129	Same as R2				
R130	Same as R1				
R131	Same as R1				
R132	Same as R1				
R133	Resistor, Fixed, 150k Ω , 5%	2	841414-125		14632
R134	Same as R50				
R135	Same as R7				
R136	Same as R26				
R137	Same as R26				
R138	Same as R30				
R139	Same as R2				
R140	Same as R1				
R141	Same as R1				
R142	Same as R18				
R143	Same as R18				
R144	Same as R1				
R145	Same as R18				
R146	Same as R55				
R147	Resistor, Fixed, 150 Ω , 5%	1	841414-053		14632
R148	Resistor, Fixed, 3.3k Ω , 5%	9	841414-085		14632
R149	Same as R1				
R150	Same as R1				
R151	Resistor, Fixed, 10 Ω , 5%	5	841414-025		14632
R152	Same as R18				
R153	Same as R18				
R154	Same as R133				
R155	Resistor, Fixed, 4.7 Ω , 5%	1	841414-017		14632
R156	Not Used				
R157	Same as R7				
R158	Same as R7				
R159	Same as R7				
R160	Same as R26				
R161	Same as R26				
R162	Same as R30				
R163	Same as R2				
R164	Same as R3				
R165	Same as R1				
R166	Same as R7				
R167	Same as R7				
R168	Same as R18				

WJ-8711A DIGITAL HF RECEIVER

<i>REF DESIG</i>	<i>DESCRIPTION</i>	<i>QTY PER ASSY</i>	<i>MANUFACTURERS PART NO.</i>	<i>MFR. CODE</i>	<i>RECM VENDOR</i>
----------------------	--------------------	-----------------------------	-----------------------------------	----------------------	------------------------

REF DESIG PREFIX A2

R169	Resistor, Fixed, 220Ω, 5%	3	841414-057	14632	
R170	Same as R7				
R171	Same as R1				
R172	Same as R151				
R173	Same as R7				
R174	Same as R7				
R175	Not Used				
R176	Same as R29				
R177	Same as R1				
R178	Same as R7				
R179	Same as R1				
R180	Same as R2				
R181	Not Used				
R182	Not Used				
R183	Same as R2				
R184	Same as R29				
R185	Same as R7				
R186	Same as R19				
R187	Same as R2				
R188	Same as R151				
R189	Not Used				
R190	Same as R29				
R191	Same as R19				
R192	Not Used				
R193	Same as R1				
R194	Same as R1				
R195	Same as R7				
R196	Same as R7				
R197	Same as R148				
R198	Same as R148				
R199	Same as R151				
R200	Same as R18				
R201	Same as R19				
R202	Same as R148				
R203	Same as R148				
R204	Not Used				
R205	Same as R19				
R206	Same as R151				
R207	Same as R1				
R208	Same as R1				
R209	Same as R19				
R210	Same as R1				
R211	Same as R19				

<i>REF DESIG</i>	<i>DESCRIPTION</i>	<i>QTY PER ASSY</i>	<i>MANUFACTURERS PART NO.</i>	<i>MFR. CODE</i>	<i>RECM VENDOR</i>
----------------------	--------------------	-----------------------------	-----------------------------------	----------------------	------------------------

REF DESIG PREFIX A2

R212	Same as R1				
R213	Not Used				
R214	Same as R19				
R215	Same as R1				
R216	Same as R19				
R217	Resistor, Fixed, 5.6kΩ, 5%	1	841414-091	14632	
R218	Same as R148				
R219	Same as R9				
R220	Same as R5				
R221	Same as R5				
R222	Same as R9				
R223	Same as R7				
R224	Same as R1				
R225	Not Used				
R226	Same as R8				
R227	Same as R3				
R228	Same as R8				
R229	Same as R1				
R230	Same as R1				
R231	Same as R19				
R232	Same as R1				
R233	Same as R1				
R234	Not Used				
R235	Same as R1				
R236	Not Used				
R237	Same as R1				
R238	Not Used				
R239	Same as R1				
R240	Same as R7				
R241	Same as R8				
R242	Same as R8				
R243	Same as R7				
R244	Same as R1				
R245	Same as R7				
R246	Same as R1				
R247	Resistor, Fixed, 1.0 MΩ 5%	4	841414-145	14632	
R248	Same as R2				
R249	Same as R1				
R250	Same as R7				
R251	Same as R7				
R252	Same as R2				
R253	Same as R1				
R254	Same as R1				

WJ-8711A DIGITAL HF RECEIVER

<i>REF DESIG</i>	<i>DESCRIPTION</i>	<i>QTY PER ASSY</i>	<i>MANUFACTURERS PART NO.</i>	<i>MFR. CODE</i>	<i>RECM VENDOR</i>
----------------------	--------------------	-----------------------------	-----------------------------------	----------------------	------------------------

REF DESIG PREFIX A2

R255	Same as R7
R256	Same as R1
R257	Same as R1
R258	Same as R1
R259	Same as R1
R260	Same as R1
R261	Same as R1
R262	Not Used
R263	Not Used
R264	Not Used
R265	Same as R5
R266	Same as R1
R267	Same as R1
R268	Same as R1
R269	Not Used
R270	Same as R7
R271	Same as R19
R272	Same as R1
R273	Same as R7
R274	Same as R7
R275	Same as R1
R276	Same as R1
R277	Same as R1
R278	Same as R7
R279	Not Used
R280	Same as R19
R281	Same as R1
R282	Same as R1
R283	Same as R7
R284	Not Used
R285	Not Used
R286	Same as R247
R287	Not Used
R288	Same as R1
R289	Same as R19
R290	Same as R1
R291	Not Used
R292	Same as R1
R293	Same as R19
R294	Same as R19
R295	Not Used
R296	Same as R19
R297	Same as R55

<i>REF DESIG</i>	<i>DESCRIPTION</i>	<i>QTY PER ASSY</i>	<i>MANUFACTURERS PART NO.</i>	<i>MFR. CODE</i>	<i>RECM VENDOR</i>
----------------------	--------------------	-----------------------------	-----------------------------------	----------------------	------------------------

REF DESIG PREFIX A2

R298	Same as R7				
R299	Not Used				
R300	Not Used				
R301	Same as R19				
R302	Same as R5				
R303	Same as R7				
R304	Same as R1				
R305	Same as R1				
R306	Same as R18				
R307	Same as R59				
R308	Same as R7				
R309	Not Used				
R310	Same as R7				
R311	Same as R7				
R312	Same as R1				
R313	Same as R1				
R314	Same as R5				
R315	Same as R7				
R316	Same as R5				
R317	Same as R1				
R318	Same as R5				
R319	Same as R1				
R320	Same as R50				
R321	Same as R1				
R322	Same as R1				
R323	Same as R18				
R324	Same as R5				
R325	Same as R1				
R326	Same as R1				
R327	Same as R18				
R328	Same as R7				
R329	Same as R1				
R330	Same as R9				
R331	Same as R1				
R332	Same as R1				
R333	Resistor, Fixed, 6.8 k Ω , 5%	2	841414-093	14632	
R334	Same as R8				
R335	Not Used				
R336	Same as R1				
R337	Same as R333				
R338	Same as R148				
R339	Same as R148				
R340	Resistor, Fixed, 68 Ω , 5%	2	841414-045	14632	

WJ-8711A DIGITAL HF RECEIVER

<i>REF DESIG</i>	<i>DESCRIPTION</i>	<i>QTY PER ASSY</i>	<i>MANUFACTURERS PART NO.</i>	<i>MFR. CODE</i>	<i>RECM VENDOR</i>
----------------------	--------------------	-----------------------------	-----------------------------------	----------------------	------------------------

REF DESIG PREFIX A2

R341	Same as R247				
R342	Same as R247				
R343	Same as R2				
R344	Same as R1				
R345	Same as R1				
R346	Same as R1				
R347	Same as R1				
R348	Same as R1				
R349	Same as R1				
R350	Same as R1				
R351	Same as R1				
R352	Same as R1				
R353	Same as R1				
R354	Same as R1				
R355	Same as R1				
R356	Same as R1				
R357	Same as R1				
R358	Same as R1				
R359	Same as R1				
R360	Same as R7				
R361	Same as R340				
R362	Not Used				
R363	Same as R19				
R364	Not Used				
R365	Not Used				
R366	Same as R50				
R367	Same as R5				
R368	Same as R5				
R369	Same as R5				
R370	Same as R50				
R371	Same as R50				
R372	Same as R169				
R373	Same as R50				
R374	Same as R50				
R375	Same as R169				
R376	Same as R19				
R377	Same as R148				
R378	Same as R2				
R379	Not Used				
S1	Switch/ Dip SPST Side Actuated Dip	2	ADP08S	95146	
S2	Same as S1				
T1	Transformer CPLG Audio 600CT/ 500CT IMP=10%,	2	SPT-130	20462	
T2	Same as T1				

REF DESIG	DESCRIPTION	QTY PER ASSY	MANUFACTURERS PART NO.	MFR. CODE	RECM VENDOR
--------------	-------------	--------------------	---------------------------	--------------	----------------

REF DESIG PREFIX A2

U1	Integrated Circuit, Microcontroller, Microcontroller Unit 16-BIT Timer 8 Channel 8-BIT	1	MC68GC11A0FN	04713	
XU1	Socket 52-POS PLCC .050 CTRS 1.050 X .20HT Polarized Surf	1	213-052-601	26742	
U2	Integrated Circuit, TRIState Octal D-Type Latch SO L20 Wide Pkg	1	74HC373SO I20	02735	
U3	Integrated Circuit, Octal TRI-State Buffer, SO L20 Wide Pkg	4	74HC244 SO I20	04713	
U4	Integrated Circuit, Quad 2-Input NAND Gate SO-14N	1	74HC00 SO 14	02735	
U5	Integrated Circuit, RAM, 8K X 8 Nonvolatile Time Keeping RAM 120NS=AT 28-Pin	1	DS1643-120	0B0A9	
XU5	Socket, IC 28 Pin .600 Row Spacing On .100 CTRS Gold Contact	2	O-628-SGT	S5322	
U6	Integrated Circuit, CMOS, Triple Three Input OR Gate SO-14 PISTC PKG	1	74HC4075 SO 14	02735	
U7	Integrated Circuit, TRIPLE 3-Input NOR Gates	1	74HC27 SO 14	02735	
U8	Integrated Circuit, 3-TO-8 Line Decoder	1	74HC138 SO 16	02735	
U9	Integrated Circuit, CMOS, Quad Buffer/ Line Driver	2	74HC125 SO 14	34371	
U10	Integrated Circuit, Triple 3-Input AND Gate	1	74F11 SO 14	04713	
U11	Integrated Circuit, 1-OF-8 Decoder/ Demultiplexer	1	74F138 SO 16	04713	
U12	EPRO M Programmed	1	842032	14632	
XU12	socket, IC 32-PIN LOW PROFILE DIP Socket .600 Row Splice Gold	1	O-632-SGT	S532	
U13	Integrated Circuit, 16-BIT A/ D Converter 20-Pin PISTC DIP	1	DSP56ADC16S	04713	
U14	Same as U3				
U15	Integrated Circuit, Octal D Flip-Flops With Clear SO L20 Wide Pkg	1	74HC273 SO I20		
U16	Same as U9				
U17	Same as U3				
U18	Not Used				
U19	Same as U3				
U20	Integrated Circuit, Line Driver and Receiver Monolithic 8 Pin PKS	2	SN75155D	01295	
U21	Integrated Circuit, CMOS, Hex Inverters Active Outputs	3	74AC04 SO 14	04713	
U22	Amplifier Ultra-High Frequency Op. Amp Gain Bandwidth 1.	1	NE5539D	18324	
U23	Integrated Circuit, Dual D Flip-Flop With Preset and Clear	3	74HC74 SO 14	04713	
U24	Integrated Circuit, CMOS, 14-Stage Binary Ripple Counter	2	74HC4020 SO 16	34371	
U25	Integrated Circuit, CMOS, Parallel-In/ Serial-OUT 8-BIT Shift Register SO-1	1	74HC165 SO 16	02735	
U26	Integrated Circuit, / INV Hex Inverter	1	74HC04 SO 14	04713	
U27	Integrated Circuit, SYN Presettable Binary Counter	2	74AC161 SO 16	34371	

WJ-8711A DIGITAL HF RECEIVER

REF DESIG	DESCRIPTION	QTY PER ASSY	MANUFACTURERS PART NO.	MFR. CODE	RECM VENDOR
U28	Same as U27				
U29	Same as U23				
U30	Integrated Circuit, Synchronous Binary Counter with Asynchronous Clear SO	1	74HC161 SO16	02735	
U31	Same as U23				
U32	Same as U21				
U33	Integrated Circuit, CMOS, Dual D Flip-Flop With PRESET AND CLEAR	1	74AC74CO14	02735	
U34	Voltage Regulator 3 TERM NEG Volt Regulator -5V	1	MC79M05CDT	04713	
U35	Same as U24				
U36	Same as U21				
U37	Integrated Circuit, 40 MHZ DSP Microprocessor with PLL 24-BIT 132-PIN PQF	1	DSP56002FC40	04713	
U38	Same as U20				
U39	Integrated Circuit, / SRAM CMOS, 32K X 8 20NS Access Time 28PIN SOJ	6	MT5C2568DJ20	6Y440	
U40	Same as U39				
U41	Same as U39				
U42	Integrated Circuit, / Sensing Undervoltage Sensing Rest Operation W / 1V Input	1	MC34064D-5	04713	
U43	Not Used				
U44	Integrated Circuit, Differential Bus Transceiver	2	SN75176AD	01295	
U45	Same as U39				
U46	Same as U39				
U47	Same as U39				
U48	Integrated Circuit, Octal D Flip-Flop with RESET SO L20 PKG	2	74HC1273 SO120	02735	
U49	Integrated Circuit, Dual D Flip-Flop with SET and RESET	1	74HC174 SO14	34371	
U50	Same as U48				
U51	Integrated Circuit, / CONV D/ A Monolithic 8-BIT HS Current Output	2	DAC08001CM	27014	
U52	Amplifier JFET Input Dual OP AMP	7	MC34002D	04713	
U53	Integrated Circuit, Quad 2-Input AND Gate	1	74HC08 SO14	02735	
U54	Same as U52				
U55	Same as U51				
U56	EPRO M Programmed	1	842033	14632	
XU56	Same as XU5				
U57	Same as U44				
U58	Integrated Circuit, Dual 1-OF4 Decoder/ Demultiplexer	1	74F139 SO16	04713	
U59	Integrated Circuit, / CONV D/ A 16 Bit Audio D/ A Converter	1	AD1851R	24355	
U60	Integrated Circuit, CMOS, Triple 2-Channel Analog Multiplexer/ Demultiplexer	3	74HC4053 SO16	02735	

REF DESIG PREFIX A2

<i>REF DESIG</i>	<i>DESCRIPTION</i>	<i>QTY PER ASSY</i>	<i>MANUFACTURERS PART NO.</i>	<i>MFR. CODE</i>	<i>RECM VENDOR</i>
----------------------	--------------------	-----------------------------	-----------------------------------	----------------------	------------------------

REF DESIG PREFIX A2

U61	Same as U52				
U62	Same as U60				
U63	Same as U52				
U64	Same as U52				
U65	Amplifier Single Low Noise OP AMP SO 8 PIN	3	NE5534D	18324	
U66	Same as U65				
U67	Integrated Circuit, Dynamic Range Processor Dual VCA 16-Pin DIP	1	SSM-2122P	06665	
U68	Same as U60				
U69	Amplifier JFET-Input Operational Amplifier	2	MC34001D	04713	
U70	Same as U69				
U71	Same as U52				
U72	Integrated Circuit, / AMP 1.5W Audio Power AMP 14-PIN DIP	1	LM388N-1	27014	
U73	Not Used				
U74	Same as U52				
U75	Same as U65				
VR1	Not Used				
XTB1	Connector, Header,13-POS Shrouded PC MT	1	ELFH13210	58982	
Y1	Not Used				

WJ-8711A DIGITAL HF RECEIVER

REF DESIG	DESCRIPTION	QTY PER ASSY	MANUFACTURERS PART NO.	MFR. CODE	RECM VENDOR
--------------	-------------	--------------------	---------------------------	--------------	----------------

8.6.2B TYPE 904978-1 DIGITAL CONTROL PC ASSEMBLY

REF DESIG PREFIX A2

Revision D

BT1	Not Used				
XBT1	Not Used				
BT2	Not Used				
XBT2	Not Used				
C1	Capacitor, Ceramic, .01 μ F, 10%	113	08055C103KAT050	04222	
C2	Same as C1				
C3	Same as C1				
C4	Capacitor, Ceramic, .033 μ F, 10%	16	08055C333KAT050M	04222	
C5	Same as C4				
C6	Same as C4				
C7	Same as C4				
C8	Same as C4				
C9	Same as C4				
C10	Same as C4				
C11	Same as C1				
C12	Capacitor, Ceramic, .1 μ F, 10%, \geq 50VDC	19	12065C104KAT050M	04222	
C13	Same as C1				
C14	Capacitor, Ceramic, 470pF, 5%	9	08055A471JAT050M	04222	
C15	Capacitor, Tantalum, 3.3 μ F, 20%, 16V	10	293D335X0016B2T	56289	
C16	Same as C12				
C17	Capacitor, Ceramic, 22pF, 5%	3	08051A220JAT050M 100V	04222	
C18	Same as C1				
C19	Same as C1				
C20	Capacitor, Ceramic, 100pF, 5%	9	08051A101JATM	04222	
C21	Same as C20				
C22	Same as C20				
C23	Same as C20				
C24	Same as C1				
C25	Capacitor, Electrolytic, Aluminum, 470 F, 16V	1	ECA-1EM471	54473	
C26	Same as C1				
C27	Capacitor, Ceramic, .047 μ F, 10%	10	C0805C473K3RAC7215	0J48	
C28	Same as C27				
C29	Same as C1				
C30	Same as C4				
C31	Same as C4				
C32	Same as C1				
C33	Same as C4				
C34	Same as C1				
C35	Same as C15				
C36	Same as C1				
C37	Same as C1				
C38	Same as C12				

<i>REF DESIG</i>	<i>DESCRIPTION</i>	<i>QTY PER ASSY</i>	<i>MANUFACTURERS PART NO.</i>	<i>MFR. CODE</i>	<i>RECM VENDOR</i>
----------------------	--------------------	-----------------------------	-----------------------------------	----------------------	------------------------

REF DESIG PREFIX A2

C39	Same as C1				
C40	Capacitor, Tantalum, 10µF, 20%, 16V	1	293D106X0016C2T	56289	
C41	Same as C17				
C42	Same as C17				
C43	Same as C12				
C44	Same as C1				
C45	Same as C12				
C46	Not Used.				
C47	Same as C1				
C48	Same as C12				
C49	Same as C14				
C50	Same as C14				
C51	Same as C14				
C52	Same as C14				
C53	Same as C14				
C54	Same as C1				
C55	Same as C1				
C56	Capacitor, Ceramic, 4700pF, 10%	1	C0805C472BRAC	0J48	
C57	Capacitor, Ceramic, 47pF, 2%	4	C0805C470C5GAC	0J48	
C58	Same as C1				
C59	Same as C1				
C60	Same as C1				
C61	Same as C15				
C62	Same as C15				
C63	Same as C15				
C64	Same as C1				
C65	Same as C1				
C66	Same as C1				
C67	Same as C1				
C68	Same as C1				
C69	Same as C1				
C70	Same as C1				
C71	Same as C15				
C72	Capacitor, Ceramic, 1000pF, 10%	1	08055C102KAT050M	04222	
C73	Same as C72				
C74	Same as C14				
C75	Same as C27				
C76	Same as C27				
C77	Capacitor, Ceramic, 1200pF, 10%,	1	0805N122G101NTM	65238	
C78	Same as C27				
C79	Capacitor, Ceramic, 1500pF, 10%,	2	08055C152KAT050M	04222	
C80	Same as C79				
C81	Capacitor, Ceramic, 820pF, 2%	2	0805N821G101NTM	65238	

WJ-8711A DIGITAL HF RECEIVER

REF DESIG	DESCRIPTION	QTY PER ASSY	MANUFACTURERS PART NO.	MFR. CODE	RECM VENDOR
--------------	-------------	--------------------	---------------------------	--------------	----------------

REF DESIG PREFIX A2

C82	Same as C14				
C83	Same as C1				
C84	Same as C1				
C85	Same as C1				
C86	Same as C14				
C87	Same as C1				
C88	Same as C1				
C89	Same as C1				
C90	Same as C1				
C91	Same as C1				
C92	Same as C1				
C93	Same as C1				
C94	Same as C12				
C95	Capacitor, Ceramic, 560pF, 10%	4	C0805COG101-561GN6E	0XN17	
C96	Same as C95				
C97	Same as C57				
C98	Same as C1				
C99	Same as C1				
C100	Same as C1				
C101	Same as C27				
C102	Same as C1				
C103	Same as C15				
C104	Same as C15				
C105	Same as C4				
C106	Capacitor, Ceramic, 220pF, 5%	1	GRM40COG221J050BD	72982	
C107	Same as C1				
C108	Same as C27				
C109	Same as C12				
C110	Same as C1				
C111	Same as C1				
C112	Same as C15				
C113	Capacitor, Ceramic, 330pF, 5%	1	GRM40COG331J050BD	72982	
C114	Same as C27				
C115	Same as C57				
C116	Same as C1				
C117	Same as C95				
C118	Same as C95				
C119	Same as C1				
C120	Same as C1				
C121	Same as C15				
C122	Same as C57				
C123	Same as C4				
C124	Capacitor, Ceramic, 2200pF, 10%	2	08055C222KAT050M	04222	

<i>REF DESIG</i>	<i>DESCRIPTION</i>	<i>QTY PER ASSY</i>	<i>MANUFACTURERS PART NO.</i>	<i>MFR. CODE</i>	<i>RECM VENDOR</i>
----------------------	--------------------	-----------------------------	-----------------------------------	----------------------	------------------------

REF DESIG PREFIX A2

C125	Capacitor, Ceramic, 180pF, 2%	1	0805N181G101NTM	65238	
C126	Capacitor, Ceramic, 470pF, 2%	1	0805N471G101NTM	65238	
C127	Same as C27				
C128	Capacitor, Ceramic, 150pF, 2%	1	0805N151G101NTM	65238	
C129	Same as C1				
C130	Same as C1				
C131	Not Used				
C132	Same as C1				
C133	Same as C1				
C134	Same as C1				
C135	Not Used				
C136	Same as C1				
C137	Same as C1				
C138	Same as C81				
C139	Same as C1				
C140	Same as C1				
C141	Same as C1				
C142	Not Used				
C143	Same as C1				
C144	Capacitor, Ceramic, 1000pF, 2%	2	C080C0G500-102GN6E	0XN17	
C145	Same as C1				
C146	Same as C1				
C147	Same as C1				
C148	Capacitor, Ceramic, 270pF, 2%	4	0805N271G101NX1M	65238	
C149	Same as C148				
C150	Same as C148				
C151	Same as C148				
C152	Same as C1				
C153	Same as C1				
C154	Same as C1				
C155	Same as C1				
C156	Same as C1				
C157	Same as C1				
C158	Same as C144				
C159	Capacitor, Ceramic, 120pF, 2%	1	C080C121G1GAC	31433	
C160	Same as C1				
C161	Same as C1				
C162	Capacitor, Ceramic, 1500pF, 2%	2	C0805C0G500-152GN6E	0XN17	
C163	Capacitor, Tantalum, 68µF, 20%, 6.3V	1	293D686X06R3D2T	56289	
C164	Same as C1				
C165	Same as C1				
C166	Same as C1				
C167	Same as C1				

WJ-8711A DIGITAL HF RECEIVER

<i>REF DESIG</i>	<i>DESCRIPTION</i>	<i>QTY PER ASSY</i>	<i>MANUFACTURERS PART NO.</i>	<i>MFR. CODE</i>	<i>RECM VENDOR</i>
----------------------	--------------------	-----------------------------	-----------------------------------	----------------------	------------------------

REF DESIG PREFIX A2

C168	Same as C1				
C169	Same as C1				
C170	Same as C1				
C171	Same as C72				
C172	Same as C72				
C173	Same as C1				
C174	Same as C1				
C175	Capacitor, Tantalum, 33 μ F, 20%, 16V	10	293D336X0016D2T	56289	
C176	Same as C175				
C177	Same as C124				
C178	Same as C1				
C179	Same as C175				
C180	Capacitor, Tantalum, 6.8 μ F, 20%, 6.3V	2	293D685X0010B2T	56289	
C181	Same as C180				
C182	Same as C1				
C183	Not Used				
C184	Same as C1				
C185	Same as C12				
C186	Same as C12				
C187	Same as C1				
C188	Same as C1				
C189	Same as C1				
C190	Not Used				
C191	Same as C1				
C192	Capacitor, 0.33 μ F, 20%, 16V	2	0805YC334KAT1A	9K916	
C193	Same as C1				
C194	Same as C1				
C195	Same as C1				
C196	Same as C1				
C197	Same as C1				
C198	Not Used				
C199	Not Used				
C200	Same as C1				
C201	Same as C1				
C202	Same as C175				
C203	Same as C175				
C204	Same as C175				
C205	Same as C1				
C206	Same as C20				
C207	Same as C1				
C208	Same as C1				
C209	Same as C1				
C210	Same as C1				

<i>REF DESIG</i>	<i>DESCRIPTION</i>	<i>QTY PER ASSY</i>	<i>MANUFACTURERS PART NO.</i>	<i>MFR. CODE</i>	<i>RECM VENDOR</i>
----------------------	--------------------	-----------------------------	-----------------------------------	----------------------	------------------------

REF DESIG PREFIX A2

C211	Same as C1				
C212	Same as C1				
C213	Same as C1				
C214	Same as C20				
C215	Same as C20				
C216	Same as C1				
C217	Same as C20				
C218	Same as C1				
C219	Same as C175				
C220	Same as C175				
C221	Same as C175				
C222	Same as C1				
C223	Same as C20				
C224	Same as C1				
C225	Same as C1				
C226	Same as C1				
C227	Same as C1				
C228	Same as C1				
C229	Same as C4				
C230	Same as C1				
C231	Same as C1				
C232	Not Used				
C233	Same as C4				
C234	Not Used				
C235	Same as C1				
C236	Same as C4				
C237	Same as C4				
C238	Not Used				
C239	Not Used				
C241	Same as C192				
C242	Same as C12				
C243	Same as C12				
C244	Same as C12				
C245	Same as C12				
C246	Same as C12				
C247	Same as C162				
C250	Same as C12				
C251	Same as C27				
C252	Same as C12				
C257	Same as C12				
C258	Same as C12				
C259	Capacitor, Ceramic, .047µF, 20%, 25V	1	C0603C473K3RAC	31433	
C260	Same as C175				

WJ-8711A DIGITAL HF RECEIVER

<i>REF DESIG</i>	<i>DESCRIPTION</i>	<i>QTY PER ASSY</i>	<i>MANUFACTURERS PART NO.</i>	<i>MFR. CODE</i>	<i>RECM VENDOR</i>
C261	Capacitor, Ceramic, .330pF, 2%, 50V	1	C080C331G1GAC	31433	
CR1	Not Used (SOT23)				
CR2	Diode/ Swpin Dual Swithcing Diode Reverse Volltage	2	MMBD7000IT1	04713	
CR3	Not Used				
CR4	Same as CR2				
CR5	Not Used				
FL1	Filter, 455 kHz Precision Ladder Type	1	CFS-455B	51406	
J1	Connector, Jack, BNC BNC Rt Ang , PCB/ Panel MT W / SIDR Mt Posts	1	227677-1	00779	
J2	Phone Jack, 3.5 Dia Mini Phone Jack, RES=30M	1	SB60	53337	
J3	Connector, 25-Pin D-Sub RT Ang, PC MT	1	17-213-302-25S	19112	
J4	CONN 24-Pin Term Strip Gold Flash .100 CTRS	4	67997-624H	22526	
J5	Connector, Header,6 Pos Pin Friction Lock .156 CTRS	1	26-48-2066	27264	
J6	Not Used				
J7	Same as J4				

REF DESIG	DESCRIPTION	QTY PER ASSY	MANUFACTURERS PART NO.	MFR. CODE	RECM VENDOR
--------------	-------------	--------------------	---------------------------	--------------	----------------

REF DESIG PREFIX A2

J8	Same as J4				
J9	Same as J4				
J10	Not Used				
J11	Connector, PC, BD 3 Pin SHRD HDR	1	3-102202-4	00779	
J12	Not Used				
J13	Not Used				
J14	Connector, Header, 10 Pin HDR .025SQ X.230 X.10CTR SG ID PLTD	1	SLW-105-01-G-D	55322	
J15	Not Used				
J16	Not Used				
JW 1	Not Used				
L1	Inductor, 10µH, Surface MT	3	RL1500-10	14778	
L2	Same as L1				
L3	Same as L1				
L4	Inductor, 1.0µH, ~-20%,@7.96MHZ Q MIN-25 370MA Ferrite 1210	9	B82422-A1102-K	25088	
L5	Same as L4				
L6	Same as L4				
L7	Same as L4				
L8	Same as L4				
L9	Same as L4				
L10	Same as L4				
L11	Not Used				
L12	Inductor, 3.9µH	1	1812-392J	99800	
L13	Inductor, 1800nH	1	26027NT	03550	
L14	Inductor, 390nH	1	2601NT	03550	
L15	Inductor, 150nH	1	26014NT	03550	
L16	Inductor, 4.7µH	1	1812-472J	99800	
L17	Not Used				
L18	Inductor, 1000µH	2	1812-105J	99800	
L19	Same as L18				
L20	Same as L4				
L21	Same as L4				
L22	Not Used				
L23	Not Used				
Q1	Not Used				
Q2	Transistor	3	MMBT2222ALT1	04713	
Q3	Same as Q2				
Q4	Not Used				
Q5	Not Used				
Q6	Transistor	2	2N7002	17856	
Q7	Same as Q2				
Q8	Transistor	2	MMBT3906	04713	

WJ-8711A DIGITAL HF RECEIVER

REF DESIG	DESCRIPTION	QTY PER ASSY	MANUFACTURERS PART NO.	MFR. CODE	RECM VENDOR
Q 9	Same as Q 6				
Q 10	Transistor	2	MMBT3904LT1	04713	
Q 11	Same as Q 8				
Q 12	Same as Q 10				
R1	Resistor, Fixed, 100k Ω , 5%	114	CR0805-10W-104JT	0XN17	
R2	Resistor, Fixed, 47 Ω , 5%	19	CR0805-10W-470JT	0XN17	
R3	Resistor, Fixed, 47k Ω , 5%	7	CR0805-10W-473JT	0XN17	
R4	Same as R3				
R5	Resistor, Fixed, 100 Ω , 5%	14	9C08052A1000JHFT	TBD1	6062
R6	Same as R3				
R7	Resistor, Fixed, 10k Ω , 5%	33	CR0805-10W-103JT	0XN17	
R8	Resistor, Fixed, 4.7k Ω , 5%	8	CR0805-10W-472JT	0XN17	
R9	Resistor, Fixed, 2.2k Ω , 5%	7	CR0805-10W-222JT	0XN17	
R10	Same as R2				
R11	Resistor, Fixed, 820 Ω , 5%	1	CR0805-10W-821JT	0XN17	
R12	Resistor, Fixed, 680 Ω , 5%	1	CR0805-10W-681JT	0XN17	
R13	Same as R5				
R14	Same as R5				
R15	Not Used				
R16	Not Used				
R17	Not Used				
R18	Resistor, Fixed, 1.0k Ω , 5%	22	CR0805-10W-102JT	0XN17	
R19	Jumper .05 Ω MAX 1A MIN@70C	33	CR0805-10W-000T	0XN17	
R20	Same as R19				
R21	Same as R18				
R22	Same as R19				
R23	Not Used				
R24	Same as R18				
R25	Same as R19				
R26	Resistor, Fixed, 1.5k Ω , 5%	1	CR0805-10W-152JT	0XN17	
R27	Same as R19				
R28	Same as R18				
R29	Resistor, Fixed, 2.7 Ω , 5%	4	CR0805-10W-2R7JT	0XN17	
R30	Resistor, Fixed, 22k Ω , 5%	4	CR0805-10W-223JT	0XN17	
R31	Same as R5				
R32	Same as R30				
R33	Same as R5				
R34	Same as R1				
R35	Same as R19				
R36	Resistor, Fixed, 2.7k Ω , 5%	2	CR0805-10W-272JT	0XN17	
R37	Same as R18				
R38	Same as R19				
R39	Same as R7				

REF DESIG PREFIX A2

REF DESIG	DESCRIPTION	QTY PER ASSY	MANUFACTURERS PART NO.	MFR. CODE	RECM VENDOR
--------------	-------------	--------------------	---------------------------	--------------	----------------

REF DESIG PREFIX A2

R40	Same as R7				
R41	Same as R18				
R42	Same as R7				
R43	Same as R19				
R44	Not Used				
R45	Same as R18				
R46	Same as R36				
R47	Same as R2				
R48	Same as R1				
R49	Same as R1				
R50	Resistor, Fixed, 470Ω, 5%	1	CR0805-8W-431JT	0XN17	
R51	Not Used				
R52	Resistor, Fixed, 75kΩ, 5%	2	CRCW0805-753JRT1	17826	
R53	Same as R52				
R54	Same as R1				
R55	Resistor, Fixed, 33kΩ, 5%	5	CR0805-10W-333JT	0XN17	
R56	Resistor, Fixed, 220kΩ, 5%	7	CR0805-10W-224GT	0XN17	
R57	Same as R55				
R58	Same as R56				
R59	Resistor, Fixed, 68kΩ, 5%	3	CRCW0805683J	17826	
R60	Same as R18				
R61	Same as R1				
R62	Same as R1				
R63	Resistor, Fixed, 3.0kΩ, 5%	1	841414-084	14632	
R64	Same as R1				
R65	Same as R1				
R66	Same as R1				
R67	Same as R2				
R68	Same as R56				
R69	Same as R56				
R70	Same as R2				
R71	Same as R56				
R72	Same as R56				
R73	Same as R2				
R74	Same as R59				
R75	Same as R18				
R76	Same as R1				
R77	Same as R1				
R78	Resistor, Fixed, 1.8kΩ, 5%	5	CR0805-10W-182J	0XN17	
R79	Same as R1				
R80	Same as R1				
R81	Same as R18				
R82	Same as R1				

WJ-8711A DIGITAL HF RECEIVER

<i>REF DESIG</i>	<i>DESCRIPTION</i>	<i>QTY PER ASSY</i>	<i>MANUFACTURERS PART NO.</i>	<i>MFR. CODE</i>	<i>RECM VENDOR</i>
----------------------	--------------------	-----------------------------	-----------------------------------	----------------------	------------------------

REF DESIG PREFIX A2

R83	Same as R1				
R84	Same as R1				
R85	Not Used				
R86	Same as R1				
R87	Same as R2				
R88	Same as R18				
R89	Same as R9				
R90	Same as R1				
R91	Same as R1				
R92	Same as R1				
R93	Resistor, Fixed, 470Ω, 5%	12	CR0805-10W-471JT	0XN17	
R94	Resistor, Fixed, 18kΩ, 5 %	4	CR0805-10W-183JT	0XN17	
R95	Same as R2				
R96	Same as R94				
R97	Same as R2				
R98	Same as R3				
R99	Same as R3				
R100	Same as R55				
R101	Same as R8				
R102	Same as R1				
R103	Same as R1				
R104	Same as R1				
R105	Not Used				
R106	Same as R9				
R107	Same as R94				
R108	Same as R9				
R109	Same as R94				
R110	Same as R18				
R111	Same as R7				
R112	Resistor, Fixed, 8.2kΩ, 5%	2	CR0805-10W-822JT	0XN17	
R113	Same as R112				
R114	Same as R7				
R115	Same as R1				
R116	Not Used				
R117	Same as R7				
R118	Same as R7				
R119	Same as R7				
R120	Same as R1				
R121	Same as R1				
R122	Same as R1				
R123	Same as R1				
R124	Same as R2				
R125	Same as R1				

REF DESIG	DESCRIPTION	QTY PER ASSY	MANUFACTURERS PART NO.	MFR. CODE	RECM VENDOR
--------------	-------------	--------------------	---------------------------	--------------	----------------

REF DESIG PREFIX A2

R126	Same as R18				
R127	Same as R3				
R128	Same as R7				
R129	Same as R2				
R130	Same as R1				
R131	Same as R1				
R132	Same as R1				
R133	Resistor, Fixed, 270kΩ, 5%	2	CR0805-8W 274JT	0XN17	
R134	Same as R93				
R135	Resistor, Fixed, 3.9kΩ, 5%	4	CR0805-10W 392J	0XN17	
R136	Same as R19				
R137	Same as R19				
R138	Resistor, Fixed, 11kΩ, 5%	2	CR0805-10W 113J	0XN17	
R139	Same as R93				
R140	Same as R1				
R141	Same as R1				
R142	Same as R18				
R143	Same as R18				
R144	Same as R1				
R145	Same as R18				
R146	Same as R55				
R147	Resistor, Fixed, 150Ω, 5%	1	CR0805-10W -151JT	0XN17	
R148	Resistor, Fixed, 3.3kΩ, 5%	7	CR0805-10W -332JT	0XN17	
R149	Same as R1				
R150	Same as R1				
R151	Resistor, Fixed, 10Ω, 5%	5	CR0805-10W -100JT	0XN17	
R152	Same as R18				
R153	Same as R18				
R154	Same as R133				
R155	Resistor, Fixed, 4.7Ω, 5%	1	CR0805-10W -4R7GT	0XN17	
R156	Not Used				
R157	Same as R7				
R158	Same as R7				
R159	Same as R135				
R160	Not Used				
R161	Same as R93				
R162	Same as R138				
R163	Same as R93				
R164	Same as R19				
R165	Same as R1				
R166	Same as R7				
R167	Same as R7				
R168	Same as R18				

WJ-8711A DIGITAL HF RECEIVER

<i>REF DESIG</i>	<i>DESCRIPTION</i>	<i>QTY PER ASSY</i>	<i>MANUFACTURERS PART NO.</i>	<i>MFR. CODE</i>	<i>RECM VENDOR</i>
----------------------	--------------------	-----------------------------	-----------------------------------	----------------------	------------------------

REF DESIG PREFIX A2

R169	Resistor, Fixed, 220Ω, 5%	3	CR0805-10W-221JT	0XN17	
R170	Same as R7				
R171	Same as R1				
R172	Same as R151				
R173	Same as R7				
R174	Same as R7				
R175	Not Used				
R176	Same as R29				
R177	Same as R1				
R178	Same as R7				
R179	Same as R1				
R180	Same as R2				
R181	Not Used				
R182	Not Used				
R183	Same as R2				
R184	Same as R29				
R185	Same as R7				
R186	Same as R19				
R187	Same as R2				
R188	Same as R151				
R189	Not Used				
R190	Same as R29				
R191	Same as R19				
R192	Not Used				
R193	Same as R1				
R194	Same as R1				
R195	Same as R7				
R196	Same as R1				
R197	Same as R148				
R198	Same as R148				
R199	Same as R19				
R200	Same as R19				
R201	Same as R19				
R202	Same as R148				
R203	Same as R148				
R204	Not Used				
R205	Same as R19				
R206	Same as R151				
R207	Same as R1				
R208	Same as R8				
R209	Same as R19				
R210	Same as R1				
R211	Same as R19				

REF DESIG	DESCRIPTION	QTY PER ASSY	MANUFACTURERS PART NO.	MFR. CODE	RECM VENDOR
--------------	-------------	--------------------	---------------------------	--------------	----------------

REF DESIG PREFIX A2

R212	Same as R1				
R213	Not Used				
R214	Same as R19				
R215	Same as R1				
R216	Same as R19				
R217	Resistor, Fixed, 5.6kΩ, 5%	3	CR0805-10W-562JT	0XN17	
R218	Same as R148				
R219	Same as R9				
R220	Resistor, Fixed, 160Ω, 5%	2	841414-054	14632	
R221	Same as R220				
R222	Same as R9				
R223	Same as R7				
R224	Same as R1				
R225	Not Used				
R226	Same as R8				
R227	Same as R3				
R228	Same as R8				
R229	Same as R1				
R230	Same as R1				
R231	Same as R19				
R232	Same as R1				
R233	Same as R1				
R234	Same as R2				
R235	Same as R1				
R236	Not Used				
R237	Same as R1				
R238	Same as R151				
R239	Same as R1				
R240	Same as R7				
R241	Same as R8				
R242	Same as R8				
R243	Same as R7				
R244	Same as R1				
R245	Same as R1				
R246	Same as R1				
R247	Resistor, Fixed, 1.0 MΩ 5%	4	CRCW0805105J	17826	
R248	Same as R2				
R249	Same as R1				
R250	Same as R1				
R251	Same as R7				
R252	Same as R2				
R253	Same as R1				
R254	Same as R1				

WJ-8711A DIGITAL HF RECEIVER

<i>REF DESIG</i>	<i>DESCRIPTION</i>	<i>QTY PER ASSY</i>	<i>MANUFACTURERS PART NO.</i>	<i>MFR. CODE</i>	<i>RECM VENDOR</i>
----------------------	--------------------	-----------------------------	-----------------------------------	----------------------	------------------------

REF DESIG PREFIX A2

R255	Same as R7				
R256	Same as R1				
R257	Same as R1				
R258	Same as R1				
R259	Same as R1				
R260	Same as R1				
R261	Same as R1				
R262	Not Used				
R263	Not Used				
R264	Not Used				
R265	Same as R5				
R266	Same as R1				
R267	Same as R1				
R268	Same as R1				
R269	Not Used				
R270	Same as R7				
R271	Same as R19				
R272	Same as R1				
R273	Same as R1				
R274	Same as R7				
R275	Same as R1				
R276	Same as R1				
R277	Same as R1				
R278	Same as R1				
R279	Not Used				
R280	Same as R19				
R281	Same as R1				
R282	Same as R1				
R283	Resistor, Fixed, 560Ω, 5%	1	CR0805-10W-561JT	0XN17	
R284	Not Used				
R285	Not Used				
R286	Same as R56				
R287	Not Used				
R288	Same as R1				
R289	Same as R19				
R290	Same as R1				
R291	Not Used				
R292	Same as R1				
R293	Same as R19				
R294	Same as R19				
R295	Not Used				
R296	Same as R19				
R297	Same as R55				

<i>REF DESIG</i>	<i>DESCRIPTION</i>	<i>QTY PER ASSY</i>	<i>MANUFACTURERS PART NO.</i>	<i>MFR. CODE</i>	<i>RECM VENDOR</i>
----------------------	--------------------	-----------------------------	-----------------------------------	----------------------	------------------------

REF DESIG PREFIX A2

R298	Same as R7				
R299	Not Used				
R300	Not Used				
R301	Same as R19				
R302	Same as R5				
R303	Same as R7				
R304	Same as R1				
R305	Same as R1				
R306	Same as R18				
R307	Same as R59				
R308	Same as R7				
R309	Not Used				
R310	Same as R7				
R311	Same as R7				
R312	Same as R1				
R313	Same as R1				
R314	Same as R5				
R315	Same as R7				
R316	Same as R5				
R317	Same as R1				
R318	Same as R5				
R319	Same as R1				
R320	Same as R93				
R321	Same as R1				
R322	Same as R1				
R323	Same as R18				
R324	Same as R5				
R325	Same as R1				
R326	Same as R1				
R327	Same as R18				
R328	Same as R135				
R329	Same as R1				
R330	Same as R9				
R331	Same as R1				
R332	Same as R1				
R333	Not Used				
R334	Same as R8				
R335	Not Used				
R336	Same as R1				
R337	Resistor, Fixed, 5.1k Ω , 5%	3	CR0805-10W-512GT	0XN17	
R338	Resistor, Fixed, 510 Ω , 5%	1	841414-066	14632	
R339	Not Used				
R340	Resistor, Fixed, 68 Ω , 5%	2	CR0805-10W-680JT	0XN17	

WJ-8711A DIGITAL HF RECEIVER

<i>REF DESIG</i>	<i>DESCRIPTION</i>	<i>QTY PER ASSY</i>	<i>MANUFACTURERS PART NO.</i>	<i>MFR. CODE</i>	<i>RECM VENDOR</i>
----------------------	--------------------	-----------------------------	-----------------------------------	----------------------	------------------------

REF DESIG PREFIX A2

R341	Same as R247
R342	Same as R247
R343	Same as R2
R344	Same as R1
R345	Same as R1
R346	Same as R1
R347	Same as R1
R348	Same as R1
R349	Same as R1
R350	Same as R1
R351	Same as R1
R352	Same as R1
R353	Same as R1
R354	Same as R1
R355	Same as R1
R356	Same as R1
R357	Same as R1
R358	Same as R1
R359	Same as R1
R360	Same as R135
R361	Same as R340
R362	Not Used
R363	Same as R19
R364	Not Used
R365	Not Used
R366	Same as R93
R367	Same as R5
R368	Same as R5
R369	Same as R5
R370	Same as R93
R371	Same as R93
R372	Same as R169
R373	Same as R93
R374	Same as R93
R375	Same as R169
R376	Same as R19
R377	Same as R148
R378	Same as R2
R379	Not Used
R380	Same as R93
R381	Same as R217
R382	Same as R217
R383	Same as R19

REF DESIG	DESCRIPTION	QTY PER ASSY	MANUFACTURERS PART NO.	MFR. CODE	RECM VENDOR
--------------	-------------	--------------------	---------------------------	--------------	----------------

REF DESIG PREFIX A2

R384	Same as R247				
R385	Not Used				
R386	Same as R19				
S1	Switch/Dip SPST Side Actuated Dip	2	4-1437590-1	TBD2	3538
S2	Same as S1				
T1	Transformer CPLG Audio 600CT/ 500CT IMP=10%,	2	SPT-130	20462	
T2	Same as T1				
U1	Integrated Circuit, Microcontroller, Microcontroller Unit 16-BIT Timer 8 Channel 8-BIT	1	MC68HC11E0CFN2	0G546	
U2	Integrated Circuit, TRIState Octal D-Type Latch SO L20 Wide Pkg	1	74HC373 SO L20	04713	
U3	Integrated Circuit, Octal TRIState Buffer, SO L20 Wide Pkg	4	74HC244 SO L20	04713	
U4	Integrated Circuit, Quad 2-Input NAND Gate SO-14N	1	74HC00 SO 14	1Z447	
U5	Integrated Circuit, RAM, 8K X 8 Nonvolatile Time Keeping RAM 120NS=AT 28-Pin	1	DS1643-100	0B0A9	
XU5	Socket, IC 28 Pin .600 Row Spacing On .100 CTRS Gold Contact	2	ICO-628-ZN GT	55322	
U6	Integrated Circuit, CMOS, Triple Three Input OR Gate SO-14 PLSTC PKG	1	74HC4075 SO 14	04713	
U7	Integrated Circuit, TRIPLE 3-Input NOR Gates	1	74HC27 SO 14	04713	
U8	Integrated Circuit, 3-TO-8 Line Decoder	1	74HC138 SO 16	1Z447	
U9	Integrated Circuit, CMOS, Quad Buffer/ Line Driver	2	74HC125 SO 14	34371	
U10	Integrated Circuit, Triple 3-Input AND Gate	1	74F11 SO 14	04713	
U11	Integrated Circuit, 1-O-F-8 Decoder/ Demultiplexer	1	74F138 SO 16	04713	
U12	EPROM Programmed	1	905001-001	14632	
XU12	socket, IC 32-PIN LOW PRO FILE DIP Socket .600 Row Splice Gold	1	O-632-SGT	55322	
U13	Integrated Circuit, 16-BIT A/ D Converter 20-Pin PLSTC DIP	1	AD7722AS	0HB57	
U14	Same as U3				
U15	Integrated Circuit, Octal D Flip-Flops With Clear SO L20 Wide Pkg	1	74HC273 SO L20	34371	
U16	Same as U9				
U17	Same as U3				
U18	Not Used				
U19	Same as U3				
U20	Integrated Circuit, Line Driver and Receiver Monolithic 8 Pin PKS	2	SN75155D	01295	
U21	Integrated Circuit, CMOS, Hex Inverters Active Outputs	1	74ACTQ04 SO 14	27014	
U22	Amplifier Ultra-High Frequency Op. Amp Gain Bandwidth 1.	1	NE5539D	18324	
U23	Integrated Circuit, Dual D Flip-Flop With Preset and Clear	3	74HC74 SO 14	04713	

WJ-8711A DIGITAL HF RECEIVER

<i>REF DESIG</i>	<i>DESCRIPTION</i>	<i>QTY PER ASSY</i>	<i>MANUFACTURERS PART NO.</i>	<i>MFR. CODE</i>	<i>REC'D VENDOR</i>
REF DESIG PREFIX A2					
U24	Integrated Circuit, CMOS,14-Stage Binary Ripple Counter	2	74HC4020 SO 16	34371	
U25	Integrated Circuit, CMOS,Parallel-In/ Serial-OUT 8-BIT Shift Register SO-1	1	74HC165 SO 16	02735	
U26	Integrated Circuit, / INV Hex Inverter	1	74HC04 SO 14	04713	
U27	Integrated Circuit, SYN Presettable Binary Counter	2	74AC161 SO 16	34371	
U28	Same as U27				
U29	Same as U23				
U30	Integrated Circuit, Synchronous Binary Counter with Asynchronous Clear SO	1	74HC161 SO 16	02735	
U31	Same as U23				
U32	Integrated Circuit, Hex Interter, Active Outputs	2	74AC04 SO 14	04713	
U33	Integrated Circuit, CMOS, Dual D Flip-Flop With PRESET AND CLEAR	1	74AC74 SO 14	02735	
U34	Voltage Regulator 3 TERM NEG Volt Regulator -5V	1	79M05	04713	
U35	Same as U24				
U36	Same as U32				
U37	Integrated Circuit, 40 MHz DSP Microprocessor with PLL 24-BIT 132-PIN PQF	1	DSP56002FC66	04713	
U38	Same as U20				
U39	Integrated Circuit, / SRAM CMOS, 32K X 8 20NS Access Time 28PIN SO J	6	CY7C199-20VC	65786	
U40	Same as U39				
U41	Same as U39				
U42	Integrated Circuit, / Sensing Undervoltage Sensing Rest Operation W / 1V Input	1	MC34064D-5	04713	
U43	Not Used				
U44	Integrated Circuit, Differential Bus Transceiver	2	DS75176BM	27014	
U45	Same as U39				
U46	Same as U39				
U47	Same as U39				
U48	Integrated Circuit, Octal D Flip-Flop with RESET SO L20 PKG	2	74HCT273 SO 120	04713	
U49	Integrated Circuit, Dual D Flip-Flop with SET and RESET	1	74HCT74 SO 14	34371	
U50	Same as U48				
U51	Integrated Circuit, / CONV D / A Monolithic 8-BIT HS Current Output	2	DAC-08ED	04713	
U52	Amplifier JFET-Input Dual OP AMP	7	TLO 82BCD	01295	
U53	Integrated Circuit, Quad 2-Input AND Gate	1	74HC08 SO 14	12447	
U54	Same as U52				
U55	Same as U51				
U56	EPROM Programmed	1	641204	14632	
XU56	Same as XU5				
U57	Same as U44				
U58	Integrated Circuit, Dual 1-OF4 Decoder/ Demultiplexer	1	74F139 SO 16	04713	

<i>REF DESIG</i>	<i>DESCRIPTION</i>	<i>QTY PER ASSY</i>	<i>MANUFACTURERS PART NO.</i>	<i>MFR. CODE</i>	<i>RECM VENDOR</i>
----------------------	--------------------	-----------------------------	-----------------------------------	----------------------	------------------------

REF DESIG PREFIX A2

U59	Integrated Circuit, / CONV D/ A 16 Bit Audio D/ A Converter	1	AD1851R	24355	
U60	Integrated Circuit, CMOS, Triple 2-Channel Analog Multiplexer/ Demultiplexer	3	74HC4053 SO16	04713	
U61	Same as U52				
U62	Same as U60				
U63	Same as U52				
U64	Same as U52				
U65	Amplifier Single Low Noise OP AMP SO 8 PIN	3	NE5534D	18324	
U66	Same as U65				
U67	Integrated Circuit, Dynamic Range Processor Dual VCA 16-Pin DIP	1	SSM2164S	0HB57	
U68	Same as U60				
U69	Amplifier JFET Input Operational Amplifier	2	TL081BCD	04713	
U70	Same as U69				
U71	Same as U52				
U72	Integrated Circuit, / AMP 1.5W Audio Power AMP 14-PIN DIP	1	LM1877N-9	27014	
U73	Not Used				
U74	Same as U52				
U75	Same as U65				
VR1	Not Used				
XTB1	Connector, Header, 13-POS Shrouded PC MT	1	ELFH13210	58982	
Y1	Not Used				

WJ-8711A DIGITAL HF RECEIVER

REF DESIG	DESCRIPTION	QTY PER ASSY	MANUFACTURERS PART NO.	MFR. CODE	RECM VENDOR
--------------	-------------	--------------------	---------------------------	--------------	----------------

8.6.3 TYPE 797006-1 RF TUNER PC ASSEMBLY

REF DESIG PREFIX A3

	Revision N1				
C1	Not Used				
C2	Not Used				
C3	Capacitor, Ceramic: .01 μ F, 10%, 50 V	140	841415-019	14632	
C4	Same as C3				
C5	Same as C3				
C6	Not Used				
C7					
Thru	Same as C3				
C10					
C11	Capacitor, Ceramic: 56 pF, 2%, 50 V NPO	4	841416-043	14632	
C12	Capacitor, Ceramic: .1 μ F, 10%, 50 VDC	80	841250-25	14632	
C13	Same as C12				
C14	Same as C12				
C15	Same as C3				
C16	Same as C12				
C17					
Thru	Same as C3				
C22					
C23	Capacitor, Ceramic: 160 pF, 2%, 50 V NPO	2	841414-054	14632	
C24	Not Used				
C25	Capacitor, Ceramic: 8.2 pF, ± 2.5 pF, 50 V	1	8414116-023	14632	
C26	Same as C23				
C27	Capacitor, Ceramic: 27 pF, 2%, 50 V NPO	3	841416-035	14632	
C28	Same as C11				
C29	Capacitor, Ceramic: 82 pF, $\pm 2\%$, 50 V NPO	3	841416-047	14632	
C30	Not Used				
C31	Same as C3				
C32	Same as C3				
C33					
Thru	Same as C12				
C37					
C38	Capacitor, Ceramic: 22 pF, 5%, 50 V NPO	6	841415-003	14632	
C39					
Thru	Same as C3				
C41					
C42	Same as C38				
C43	Capacitor, Ceramic: 91 pF, $\pm 2\%$, 50 V NPO	2	841416-048	14632	
C44	Capacitor, Ceramic: 33 pF, $\pm 2\%$, 50 V NPO	1	841416-037	14632	
C45	Capacitor, Ceramic: 130 pF, 2%, 50 V NPO	1	841416-052	14632	
C46	Same as C43				
C47	Capacitor, Ceramic: 100 pF, 2%, 50 V NPO	9	841416-049	14632	
C48	Capacitor, Ceramic: 1500 pF, 10%, 50 V	3	841415-014	14632	

REF DESIG	DESCRIPTION	QTY PER ASSY	MANUFACTURERS PART NO.	MFR. CODE	RECM VENDOR
--------------	-------------	--------------------	---------------------------	--------------	----------------

REF DESIG PREFIX A3

C49	Capacitor, Ceramic: 470 pF, 5%, 50 V NPO	3	841415-011	14632	
C50	Not Used				
C51	Same as C47				
C52	Same as C3				
C53	Same as C3				
C54	Same as C12				
C55	Same as C12				
C56	Same as C3				
C57	Same as C38				
C58	Same as C3				
C59	Same as C38				
C60	Same as C3				
C61	Capacitor, Tantalum: 2.2 μ F, 20%, 20 V	4	841293-09	f14632	
C62	Same as C3				
C63	Capacitor, Tantalum: 3.3 μ F, 20%, 16 V	13	841293-10	14632	
C64	Same as C3				
C65	Same as C3				
C66	Same as C61				
C67	Same as C3				
C68	Capacitor, Tantalum: 33 μ F, 20%, 16 V	15	841293-22	14632	
C69					
Thru	Same as C12				
C75					
C76	Same as C61				
C77	Same as C61				
C78	Capacitor, Ceramic: 1000 pF, 10%, 50 V	10	841415-013	14632	
C79	Same as C68				
C80					
Thru	Same as C3				
C84					
C85	Capacitor, Tantalum: 4.7 μ F, 20%, 25 V	2	841293-13	14632	
C86					
Thru	Same as C12				
C89					
C90	Same as C68				
C91	Same as C12				
C92	Not Used				
C93	Same as C3				
C94	Capacitor, Ceramic: 2200 pF, 10%, 50 V	7	841415-015	14632	
C95	Same as C78				
C96	Same as C78				
C97	Same as C94				
C98	Same as C3				

WJ-8711A DIGITAL HF RECEIVER

<i>REF DESIG</i>	<i>DESCRIPTION</i>	<i>QTY PER ASSY</i>	<i>MANUFACTURERS PART NO.</i>	<i>MFR. CODE</i>	<i>RECM VENDOR</i>
----------------------	--------------------	-----------------------------	-----------------------------------	----------------------	------------------------

REF DESIG PREFIX A3

C99	Same as C3				
C100	Not Used				
C101	Same as C3				
C102					
Thru	Same as C12				
C110					
C111					
Thru	Same as C3				
C113					
C114	Capacitor, Tantalum: 6.8 μ F, 20%, 6.3 V	2	841293-14	14632	
C115					
Thru	Same as C3				
C118					
C119	Capacitor, Ceramic: 68 pF, 5%, 50 V NPO	2	841415-006	14632	
C120	Same as C114				
C121	Same as C12				
C122	Same as C12				
C123	Same as C63				
C124					
Thru	Same as C3				
C126					
C127					
Thru	Same as C12				
C131					
C132	Same as C3				
C133	Same as C12				
C134	Same as C12				
C135	Same as C3				
C136	Same as C3				
C137	Same as C63				
C138	Same as C12				
C139	Same as C3				
C140	Same as C47				
C141	Same as C3				
C142	Same as C47				
C143	Same as C3				
C144	Capacitor, Ceramic: 47 pF, 5%, 50 V NPO	3	841415-005	14632	
C145	Same as C63				
C146	Same as C12				
C147					
Thru	Same as C3				
C154					
C155	Same as C12				
C156	Same as C3				
C157	Same as C144				
C158	Same as C3				

<i>REF DESIG</i>	<i>DESCRIPTION</i>	<i>QTY PER ASSY</i>	<i>MANUFACTURERS PART NO.</i>	<i>MFR. CODE</i>	<i>RECM VENDOR</i>
----------------------	--------------------	-----------------------------	-----------------------------------	----------------------	------------------------

REF DESIG PREFIX A3

C159	Same as C3				
C160	Same as C12				
C161	Same as C12				
C162	Not Used				
C163	Same as C3				
C164	Same as C3				
C165	Not Used				
C166	Same as C3				
C167	Same as C68				
C168	Same as C3				
C169	Same as C3				
C170	Same as C47				
C171					
Thru	Same as C3				
C173					
C174	Not Used				
C175	Same as C49				
C176	Same as C78				
C177	Same as C63				
C178	Same as C78				
C179	Same as C119				
C180	Capacitor, Ceramic: 39 pF, 2%, 50 V NPO	1	841416-039		14632
C181	Same as C12				
C182	Same as C12				
C183	Same as C3				
C184	Not Used				
C185	Same as C47				
C186	Same as C3				
C187	Same as C94				
C188	Same as C144				
C189	Same as C47				
C190					
Thru	Same as C3				
C192					
C193	Not Used				
C194	Same as C78				
C195					
Thru	Same as C3				
C197					
C198	Same as C85				
C199	Same as C3				
C200	Same as C68				
C201	Same as C49				
C202	Not Used				

WJ-8711A DIGITAL HF RECEIVER

<i>REF DESIG</i>	<i>DESCRIPTION</i>	<i>QTY PER ASSY</i>	<i>MANUFACTURERS PART NO.</i>	<i>MFR. CODE</i>	<i>RECM VENDOR</i>
----------------------	--------------------	-----------------------------	-----------------------------------	----------------------	------------------------

REF DESIG PREFIX A3

C203	Same as C47				
C204	Same as C12				
C205	Capacitor, Tantalum: .33 μF, 20%, 35 V	8	841293-01	14632	
C206	Same as C12				
C207					
Thru	Not Used				
C211					
C212	Same as C78				
C213	Same as C47				
C214	Same as C3				
C215	Same as C3				
C216	Capacitor, Ceramic: .033 μF, 10%, 50 V	8	841415-022	14632	
C217	Same as C63				
C218	Same as C38				
C219	Same as C216				
C220	Same as C3				
C221	Not Used				
C222	Same as C3				
C223	Same as C3				
C224	Not Used				
C225	Not Used				
C226	Same as C3				
C227	Same as C3				
C228	Same as C216				
C229	Same as C3				
C230	Same as C216				
C231	Same as C3				
C232	Not Used				
C233	Same as C3				
C234					
Thru	Not Used				
C240					
C241					
Thru	Same as C3				
C245					
C246					
Thru	Same as C68				
C249					
C250	Same as C216				
C251	Same as C3				
C252	Same as C38				

<i>REF DESIG</i>	<i>DESCRIPTION</i>	<i>QTY PER ASSY</i>	<i>MANUFACTURERS PART NO.</i>	<i>MFR. CODE</i>	<i>RECM VENDOR</i>
----------------------	--------------------	-----------------------------	-----------------------------------	----------------------	------------------------

REF DESIG PREFIX A3

C253					
Thru	Same as C3				
C255					
C256	Capacitor, Tantalum: 68 μ F, 20%, 6.3 V	2	841293-24	14632	
C257	Same as C68				
C258	Same as C216				
C259	Same as C78				
C260	Same as C78				
C261	Same as C3				
C262	Same as C3				
C263	Same as C94				
C264	Capacitor, Ceramic: 330 pF, 5%, 50 V NPO	2	841415-010	14632	
C265					
Thru	Not Used				
C267					
C268	Same as C48				
C269	Same as C94				
C270	Same as C63				
C271	Same as C63				
C272	Same as C3				
C273	Same as C12				
C274	Same as C12				
C275	Same as C63				
C276	Same as C3				
C277	Same as C63				
C278	Same as C205				
C279	Same as C12				
C280	Same as C3				
C281	Same as C68				
C282	Same as C256				
C283	Same as C68				
C284	Same as C68				
C285	Same as C3				
C286	Same as C3				
C287	Same as C78				
C288	Same as C3				
C289	Same as C3				
C290	Same as C12				
C291	Same as C3				
C292	Capacitor, Ceramic: 2.2 pF, \pm 1 pF, 50 V NPO	3	841416-009	14632	
C293	Same as C292				
C294	Same as C3				
C295	Same as C27				

WJ-8711A DIGITAL HF RECEIVER

<i>REF DESIG</i>	<i>DESCRIPTION</i>	<i>QTY PER ASSY</i>	<i>MANUFACTURERS PART NO.</i>	<i>MFR. CODE</i>	<i>RECM VENDOR</i>
----------------------	--------------------	-----------------------------	-----------------------------------	----------------------	------------------------

REF DESIG PREFIX A3

C296	Same as C3				
C297	Same as C3				
C298	Same as C3				
C299	Same as C11				
C300	Same as C3				
C301	Same as C11				
C302					
Thru	Same as C3				
C304					
C305	Same as C68				
C306	Same as C3				
C307	Same as C3				
C308	Not Used				
C309	Not Used				
C310					
Thru	Same as C3				
C312					
C313	Same as C68				
C314	Not Used				
C315	Same as C27				
C316	Same as C292				
C317	Same as C12				
C318	Capacitor, Ceramic: 22 pF, 2%, 50 V NPO	2	841416-033	14632	
C319	Same as C318				
C319	Same as C318				
C320					
Thru	Same as C3				
C325					
C326	Same as C12				
C327	Same as C12				
C328	Same as C48				
C329	Same as C264				
C330					
Thru	Same as C3				
C334					
C335	Same as C29				
C336					
Thru	Same as C3				
C338					
C339	Same as C12				
C340	Same as C29				
C341	Same as C12				
C342	Same as C63				

<i>REF DESIG</i>	<i>DESCRIPTION</i>	<i>QTY PER ASSY</i>	<i>MANUFACTURERS PART NO.</i>	<i>MFR. CODE</i>	<i>RECM VENDOR</i>
----------------------	--------------------	-----------------------------	-----------------------------------	----------------------	------------------------

REF DESIG PREFIX A3

C343	Same as C12				
C344	Same as C63				
C345	Same as C12				
C346	Same as C205				
C347					
Thru	Same as C12				
C350					
C351	Same as C205				
C352					
Thru	Same as C12				
C354					
C355	Same as C205				
C356	Same as C12				
C357	Same as C3				
C358	Same as C205				
C359	Same as C3				
C360	Same as C94				
C361	Same as C216				
C362	Same as C94				
C363	Same as C3				
C364					
Thru	Same as C12				
C366					
C367	Same as C63				
C368					
Thru	Same as C12				
C370					
C371	Same as C205				
C372	Same as C12				
C373	Same as C12				
C374	Same as C205				
C375					
Thru	Same as C12				
C377					
C378	Same as C216				
CR1	Dual Switching Diode	17	MMBD7000IT1	04713	
CR2	Diode	6	BB620(Q62702-B403)	25088	
CR3					
Thru	Same as CR1				
CR10					
CR11	Same as CR2				
CR12	Same as CR2				
CR13	Same as CR1				

WJ-8711A DIGITAL HF RECEIVER

REF DESIG	DESCRIPTION	QTY PER ASSY	MANUFACTURERS PART NO.	MFR. CODE	RECM VENDOR
--------------	-------------	--------------------	---------------------------	--------------	----------------

REF DESIG PREFIX A3

CR14	Same as CR1				
CR15	Same as CR2				
CR16	Same as CR2				
CR17	Same as CR1				
CR18	Diode	6	FDSO 1503	27014	
CR19					
Thru	Same as CR18				
CR23					
CR24	Diode	6	HSMP3800-T31	28480	
CR25					
Thru	Same as CR24				
CR29					
CR30	Same as CR1				
CR31	Same as CR2				
CR32					
Thru	Same as CR1				
CR35					
E1	Cable Assembly	1	IDMD-12-T4-C	55322	
FB1	Ferrite Bead: 120Ω, ±25%	10	CB30-453215T	54583	
FB2					
Thru	Same as FB1				
FB10					
FL1	Filter, BP: 40.455 MHz	1	92609	14632	
FL2	Filter: 455 kHz	1	CFS-455B	51406	
J1	Connector, Jack, BNC	3	227677-1	00779	
J2	Same as J1				
J3	Same as J1				
J4	Not Used				
J5	Connector	1	79223-610	22526	
L1	Inductor: 1000 μH, 10%	6	841699-037	14632	
L2	Inductor: 10 μH, 10%	2	841699-013	14632	
L3	Inductor: 22 nH, ±5%	1	841438-009	14632	
L4	Inductor: 15 nH, ±5%	1	841438-005	14632	
L5	Inductor: 4700 nH, 10%	12	841698-033	14632	
L6	Inductor: 47 μH, ±10%	2	NI322522-470K	54583	
L7	Inductor: 150 nH, ±5%	2	841438-029	14632	
L8	Inductor: 68 nH, ±5%	2	841438-021	14632	
L9	Inductor: 4.7 μH, ±20%	4	B82422-A1472-M	25088	
L10	Same as L6				
L11	Same as L7				
L12	Same as L8				
L13	Same as L9				
L14	Same as L9				

REF DESIG	DESCRIPTION	QTY PER ASSY	MANUFACTURERS PART NO.	MFR. CODE	RECM VENDOR
--------------	-------------	--------------------	---------------------------	--------------	----------------

REF DESIG PREFIX A3

L15					
Thru	Same as I5				
L17					
L18	Inductor: 270 μ F, \pm 5%	2	841438-035	14632	
L19	Inductor: 330 nH, \pm 5%	1	841438-037	14632	
L20	Inductor: 220 nH, \pm 5%	4	841438-033	14632	
L21	Inductor: 160 nH, \pm 5%	1	841438-030	14632	
L22	Inductor: 180 nH, \pm 5%	1	841438-031	14632	
L23	Inductor: 240 nH, \pm 5%	1	841438-034	14632	
L24	Same as L1				
L25	Inductor: 150 μ H, 10%	2	841699-027	14632	
L26	Same as L25				
L27	Same as L1				
L28	Same as L1				
L29	Inductor: 270 μ H, 10%	13	841699-030	14632	
L30	Same as L29				
L31	Inductor: 47 μ H, 10%	4	841699-021	14632	
L32	Same as L31				
L33	Same as L31				
L34	Same as I9				
L35	Same as L29				
L36	Same as L20				
L37	Inductor: 100 nH, \pm 5%	2	841438-025	14632	
L38	Same as L37				
L39	Inductor: 4700 nH, 10%	1	841698-033	14632	
L40	Same as I5				
L41	Same as I5				
L42	Same as L18				
L43					
Thru	Same as L29				
L45					
L46					
Thru	Same as I5				
L48					
L49					
Thru	Same as L29				
L52					
L53	Not Used				
L54	Same as L29				
L55					
Thru	Not Used				
L57					
L58	Same as L29				

WJ-8711A DIGITAL HF RECEIVER

REF DESIG	DESCRIPTION	QTY PER ASSY	MANUFACTURERS PART NO.	MFR. CODE	RECM VENDOR
--------------	-------------	--------------------	---------------------------	--------------	----------------

REF DESIG PREFIX A3

I59	Same as I29				
I60	Inductor: 470 nH, ±5%	2	841438-041	14632	
I61	Same as I60				
I62	Same as I20				
I63	Same as I20				
I64	Same as I1				
I65	Same as I1				
I66	Same as I2				
I67	Same as I31				
I68	Same as I5				
I69	Same as I5				
I70	Not Used				
I71	Same as I5				
Q1	Transistor	1	MMBR2857	04713	
Q2	Transistor	15	MMBT3904LT1	04713	
Q3	Same as Q2				
Q4	Transistor	18	MMBT3906	04713	
Q5	Same as Q4				
Q6	Transistor	3	OST310	17856	
Q7	Transistor	6	MMBT3904LT1	04713	
Q8	Same as Q7				
Q9					
Thru	Same as Q2				
Q12					
Q13	Same as Q4				
Q14	Same as Q2				
Q15	Transistor	1	2N7002	17856	
Q16	Same as Q6				
Q17	Same as Q7				
Q18	Same as Q7				
Q19	Same as Q4				
Q20	Same as Q7				
Q21	Same as Q7				
Q22	Same as Q2				
Q23	Transistor	1	841381-2	14632	
Q24	Same as Q4				
Q25	Same as Q2				
Q26	Same as Q4				
Q27	Same as Q2				
Q28	Same as Q4				
Q29	Same as Q2				
Q30	Same as Q4				
Q31	Same as Q4				
Q32	Transistor	4	MRF5812	04713	

REF DESIG	DESCRIPTION	QTY PER ASSY	MANUFACTURERS PART NO.	MFR. CODE	RECM VENDOR
--------------	-------------	--------------------	---------------------------	--------------	----------------

REF DESIG PREFIX A3

Q 33					
Thru	Same as Q 32				
Q 35					
Q 36	Same as Q 2				
Q 37	Transistor	2	MMBT3960A	04713	
Q 38	Same as Q 37				
Q 39	Same as Q 6				
Q 40	Same as Q 4				
Q 41	Transistor	2	MTD10N05E	04713	
Q 42	Same as Q 4				
Q 43	Transistor	1	MTD4P05	04713	
Q 44	Same as Q 41				
Q 45	Same as Q 2				
Q 46	Same as Q 2				
Q 47	Same as Q 4				
Q 48	Same as Q 2				
Q 49					
Thru	Same as Q 4				
Q 54					
R1	Resistor, Fixed: 1.0 k Ω , 5%, 1/10 W	29	841414-073	14632	
R2	Resistor, Fixed: 680 Ω , 5%, 1/10 W	22	841414-069	14632	
R3	Same as R1				
R4	Jumper	26	841417	14632	
R5	Same as R4				
R6	Same as R2				
R7	Same as R4				
R8	Resistor, Fixed: 100 k Ω , 5%, 1/10 W	14	841414-121	14632	
R9	Same as R2				
R10	Resistor, Fixed: 10 Ω , 5%, 1/10 W	35	841414-025	14632	
R11	Resistor, Fixed: 10 k Ω , 5%, 1/10 W	19	841414-097	14632	
R12	Same as R11				
R13	Same as R1				
R14	Same as R8				
R15	Resistor, Fixed: 1.5 M Ω , 5%, 1/10 W	5	841414-149	14632	
R16	Same as R10				
R17	Resistor, Fixed: 680 k Ω , 5%, 1/10 W	5	841414-141	14632	
R18	Resistor, Fixed: 6.8 k Ω , 5%, 1/10 W	5	841414-093	14632	
R19	Resistor, Fixed: 120 k Ω , 5%, 1/10 W	2	841414-123	14632	
R20	Resistor, Fixed: 12 k Ω , 5%, 1/10 W	6	841414-099	14632	
R21	Resistor, Fixed: 4.7 k Ω , 5%, 1/10 W	16	841414-089	14632	
R22	Same as R10				
R23	Same as R20				
R24	Resistor, Fixed: 27 k Ω , 5%, 1/10 W	6	841414-107	14632	
R25	Same as R20				
R26	Same as R24				
R27	Same as R21				

WJ-8711A DIGITAL HF RECEIVER

REF DESIG	DESCRIPTION	QTY PER ASSY	MANUFACTURERS PART NO.	MFR. CODE	RECM VENDOR
					REF DESIG PREFIX A3
R28	Same as R10				
R29	Resistor, Fixed: 68 k Ω , 5%, 1/10 W	2	841414-117	14632	
R30	Same as R15				
R31	Same as R29				
R32	Same as R15				
R33	Same as R10				
R34	Resistor, Fixed: 2.2 k Ω , 5%, 1/10 W	8	841414-081	14632	
R35	Same as R15				
R36	Same as R15				
R37	Same as R17				
R38	Not Used				
R39	Same as R11				
R40	Resistor, Fixed: 330 Ω , 5%, 1/10 W	7	841414-061	14632	
R41	Same as R8				
R42	Resistor, Fixed: 3.3 k Ω , 1/10 W	10	841414-085	14632	
R43	Same as R1				
R44	Resistor, Fixed: 470 Ω , 5%, 1/10 W	19	841414-065	14632	
R45	Same as R1				
R46	Resistor, Fixed: 15 k Ω , 5%, 1/10 W	5	841414-101	14632	
R47	Not Used				
R48	Same as R11				
R49	Same as R19				
R50	Same as R10				
R51	Same as R42				
R52	Resistor, Fixed: 100 Ω , 5%, 1/10 W	17	841414-049	14632	
R53	Same as R52				
R54	Same as R10				
R55	Same as R8				
R56	Resistor, Fixed: 22 k Ω , 5%, 1/10 W	3	841414-105	14632	
R57	Same as R8				
R58	Same as R56				
R59	Resistor, Variable: 10 k Ω	1	3269X-1-103	80294	
R60	Same as R11				
R61	Same as R10				
R62	Same as R46				
R63	Same as R1				
R64	Same as R1				
R65	Not Used				
R66	Resistor, Fixed: 470 k Ω , 5%, 1/10 W	2	841414-137	14632	
R67	Same as R10				
R68	Same as R11				
R69	Same as R18				
R70	Same as R44				
R71	Same as R10				
R72	Same as R10				
R73	Same as R1				

REF DESIG	DESCRIPTION	QTY PER ASSY	MANUFACTURERS PART NO.	MFR. CODE	RECM VENDOR
--------------	-------------	--------------------	---------------------------	--------------	----------------

REF DESIG PREFIX A3

R74	Same as R52				
R75	Same as R34				
R76	Same as R8				
R77	Same as R11				
R78	Same as R11				
R79	Same as R10				
R80	Resistor, Fixed: 1.5 k Ω , 5%, 1/10 W	12	841414-077		14632
R81	Resistor, Fixed: 150 Ω , 5%, 1/10 W	6	841414-053		14632
R82	Resistor, Fixed: 470 Ω , 5%, 1/8 W	3	841296-057		14632
R83	Same as R44				
R84	Same as R82				
R85	Same as R82				
R86	Same as R24				
R87	Resistor, Fixed: 120 Ω , 5%, 1/10 W	4	841414-051		14632
R88	Resistor, Fixed: 270 Ω , 5%, 1/10 W	2	841414-059		14632
R89	Same as R24				
R90	Same as R21				
R91	Same as R66				
R92	Same as R44				
R93	Same as R2				
R94	Same as R81				
R95	Resistor, Fixed: 22 Ω , 5%, 1/10 W	7	841414-033		14632
R96	Same as R52				
R97	Same as R34				
R98	Same as R80				
R99	Resistor, Fixed: 120 Ω , 5%, 1/8 W	5	841296-043		14632
R100	Same as R99				
R101	Same as R99				
R102	Same as R81				
R103	Same as R99				
R104	Resistor, Fixed: 180 Ω , 5%, 1/10 W	5	841414-055		14632
R105	Same as R52				
R106	Same as R10				
R107	Same as R99				
R108	Same as R95				
R109	Same as R10				
R110	Same as R87				
R111	Same as R52				
R112	Same as R10				
R113	Same as R24				
R114	Resistor, Fixed: 220 Ω , 5%, 1/10 W	10	841414-057		14632
R115	Same as R114				
R116	Same as R2				

WJ-8711A DIGITAL HF RECEIVER

REF DESIG	DESCRIPTION	QTY PER ASSY	MANUFACTURERS PART NO.	MFR. CODE	RECM VENDOR
--------------	-------------	--------------------	---------------------------	--------------	----------------

REF DESIG PREFIX A3

R117	Resistor, Fixed: 47Ω, 5%, 1/10 W	15	841414-041	14632	
R118	Same as R87				
R119	Same as R1				
R120	Same as R1				
R121	Same as R87				
R122	Same as R1				
R123	Resistor, Fixed: 68Ω, 5%, 1/10 W	5	841414-045	14632	
R124	Same as R123				
R125					
Thru	Same as R44				
R127					
R128	Same as R123				
R129	Same as R80				
R130	Same as R1				
R131	Same as R44				
R132	Same as R21				
R133	Resistor, Fixed: 33 kΩ, 5%, 1/10 W	3	841414-109	14632	
R134	Same as R21				
R135	Same as R44				
R136	Same as R21				
R137	Same as R133				
R138	Same as R21				
R139	Same as R21				
R140	Same as R114				
R141	Same as R21				
R142	Same as R133				
R143	Same as R21				
R144	Same as R10				
R145					
Thru	Same as R8				
R147					
R148	Same as R114				
R149	Resistor, Fixed: 2.7 kΩ, 5%, 1/10 W	8	841414-083	14632	
R150					
Thru	Same as R21				
R152					
R153	Same as R24				
R154	Same as R20				
R155	Same as R8				
R156	Same as R10				
R157	Same as R11				
R158	Same as R149				
R159	Same as R11				

REF DESIG	DESCRIPTION	QTY PER ASSY	MANUFACTURERS PART NO.	MFR. CODE	RECM VENDOR
--------------	-------------	--------------------	---------------------------	--------------	----------------

REF DESIG PREFIX A3

R160	Same as R21				
R161	Same as R21				
R162	Same as R52				
R163	Same as R42				
R164	Same as R44				
R165	Same as R10				
R166	Same as R88				
R167	Same as R149				
R168	Same as R42				
R169	Same as R10				
R170	Same as R1				
R171	Same as R149				
R172	Same as R42				
R173	Resistor, Fixed: 560Ω, 5%, 1/10 W	5	841414-067		14632
R174	Same as R42				
R175	Not Used				
R176	Same as R4				
R177	Same as R114				
R178	Same as R149				
R179	Same as R10				
R180	Same as R2				
R181	Same as R117				
R182	Same as R80				
R183	Same as R2				
R184	Same as R10				
R185	Not Used				
R186	Same as R81				
R187	Same as R40				
R188	Same as R81				
R189	Same as R117				
R190	Same as R2				
R191	Resistor, Fixed: 3.3Ω, 5%, 1/10 W	2	841414-013		14632
R192	Same as R191				
R193	Same as R4				
R194	Resistor, Fixed: 33Ω, 5%, 1/10 W	4	841414-037		14632
R195	Same as R34				
R196	Same as R8				
R197	Same as R10				
R198	Same as R10				
R199	Same as R2				
R200	Same as R2				
R201	Same as R1				
R202	Same as R46				

WJ-8711A DIGITAL HF RECEIVER

<i>REF DESIG</i>	<i>DESCRIPTION</i>	<i>QTY PER ASSY</i>	<i>MANUFACTURERS PART NO.</i>	<i>MFR. CODE</i>	<i>RECM VENDOR</i>
----------------------	--------------------	-----------------------------	-----------------------------------	----------------------	------------------------

REF DESIG PREFIX A3

R203	Same as R52
R204	Same as R117
R205	Same as R44
R206	Same as R8
R207	Same as R40
R208	Same as R44
R209	Same as R4
R210	Same as R194
R211	Same as R117
R212	Same as R2
R213	Same as R42
R214	Same as R2
R215	Same as R42
R216	
Thru	Same as R4
R218	
R219	Same as R10
R220	Same as R114
R221	Same as R42
R222	Same as R4
R223	Same as R2
R224	Same as R4
R225	Same as R4
R226	Same as R10
R227	Same as R10
R228	Same as R2
R229	Same as R1
R230	Same as R1
R231	Same as R10
R232	Same as R42
R233	Same as R80
R234	Same as R10
R235	Same as R80
R236	
Thru	Same as R4
R241	
R242	Same as R1
R243	Same as R1
R244	Same as R4
R245	Same as R17
R246	
Thru	Same as R11
R248	

REF DESIG	DESCRIPTION	QTY PER ASSY	MANUFACTURERS PART NO.	MFR. CODE	RECM VENDOR
--------------	-------------	--------------------	---------------------------	--------------	----------------

REF DESIG PREFIX A3

R249	Resistor, Fixed: 5.6 kΩ, 5%, 1/ 10 W	6	841414-091	14632	
R250	Same as R249				
R251	Same as R10				
R252	Same as R44				
R253	Same as R114				
R254	Same as R117				
R255	Same as R8				
R256	Same as R1				
R257	Same as R46				
R258					
Thru	Same as R2				
R261					
R262	Same as R10				
R263					
Thru	Same as R4				
R265					
R266	Same as R11				
R267	Same as R10				
R268	Same as R34				
R269	Same as R10				
R270	Same as R21				
R271	Same as R17				
R272	Same as R56				
R273	Same as R11				
R274	Same as R17				
R275	Same as R2				
R276	Same as R52				
R277	Same as R2				
R278	Same as R1				
R279	Same as R1				
R280	Same as R34				
R281	Same as R8				
R282	Same as R117				
R283	Same as R1				
R284	Same as R95				
R285	Same as R1				
R286	Same as R18				
R287	Same as R80				
R288	Same as R249				
R289	Same as R173				
R290	Resistor, Fixed: 2.7Ω, 5%, 1/ 10 W	2	841414-011	14632	
R291	Same as R11				
R292	Same as R11				

WJ-8711A DIGITAL HF RECEIVER

<i>REF DESIG</i>	<i>DESCRIPTION</i>	<i>QTY PER ASSY</i>	<i>MANUFACTURERS PART NO.</i>	<i>MFR. CODE</i>	<i>RECM VENDOR</i>
----------------------	--------------------	-----------------------------	-----------------------------------	----------------------	------------------------

REF DESIG PREFIX A3

R293	Same as R10
R294	Same as R4
R295	Same as R44
R296	Same as R4
R297	Same as R114
R298	Same as R11
R299	Same as R34
R300	Same as R52
R301	Same as R52
R302	Same as R123
R303	Same as R123
R304	Same as R104
R305	Same as R104
R306	Same as R40
R307	Same as R117
R308	Same as R1
R309	Same as R117
R310	Same as R40
R311	Same as R149
R312	Same as R95
R313	Same as R117
R314	Same as R80
R315	Same as R18
R316	Same as R117
R317	Same as R1
R318	Same as R117
R319	Same as R40
R320	Same as R117
R321	Same as R149
R322	Same as R4
R323	Same as R20
R324	Same as R52
R325	Same as R4
R326	Same as R20
R327	Same as R80
R328	Same as R52
R329	Same as R173
R330	Same as R173
R331	Same as R95
R332	Same as R52
R333	Same as R95
R334	Same as R249
R335	Same as R1

<i>REF DESIG</i>	<i>DESCRIPTION</i>	<i>QTY PER ASSY</i>	<i>MANUFACTURERS PART NO.</i>	<i>MFR. CODE</i>	<i>RECM VENDOR</i>
----------------------	--------------------	-----------------------------	-----------------------------------	----------------------	------------------------

REF DESIG PREFIX A3

R336	Same as R173				
R337	Same as R52				
R338	Same as R104				
R339	Same as R114				
R340	Same as R44				
R341	Same as R117				
R342	Same as R290				
R343	Same as R44				
R344	Same as R44				
R345	Same as R18				
R346	Same as R80				
R347	Same as R1				
R348	Same as R149				
R349	Same as R44				
R350	Same as R52				
R351	Same as R34				
R352	Same as R2				
R353	Same as R44				
R354	Same as R52				
R355	Same as R11				
R356	Same as R1				
R357	Same as R1				
R358	Same as R80				
R359	Same as R80				
R360	Same as R114				
R361	Same as R117				
R362	Same as R81				
R363	Same as R249				
R364	Same as R104				
R365	Same as R46				
R366	Same as R194				
R367	Same as R10				
R368	Same as R249				
R369	Same as R194				
R370	Same as R40				
R371	Same as R10				
R372	Same as R95				
R373	Same as R2				
R374	Resistor, Fixed: 180Ω, 5%, 1/8 W	1	841296-047	14632	
T1	Transformer	1	841709-1	14632	
T2	Transformer	2	458DB-1011=P1	9AA39	
T3	Same as T2				
T4	Transformer	1	458PS-1007=T1	9AA39	

WJ-8711A DIGITAL HF RECEIVER

<i>REF DESIG</i>	<i>DESCRIPTION</i>	<i>QTY PER ASSY</i>	<i>MANUFACTURERS PART NO.</i>	<i>MFR. CODE</i>	<i>REC'D VENDOR</i>
----------------------	--------------------	-----------------------------	-----------------------------------	----------------------	-------------------------

REF DESIG PREFIX A3

R336	Same as R173				
R337	Same as R52				
R338	Same as R104				
R339	Same as R114				
R340	Same as R44				
R341	Same as R117				
R342	Same as R290				
R343	Same as R44				
R344	Same as R44				
R345	Same as R18				
R346	Same as R80				
R347	Same as R1				
R348	Same as R149				
R349	Same as R44				
R350	Same as R52				
R351	Same as R34				
R352	Same as R2				
R353	Same as R44				
R354	Same as R52				
R355	Same as R11				
R356	Same as R1				
R357	Same as R1				
R358	Same as R80				
R359	Same as R80				
R360	Same as R114				
R361	Same as R117				
R362	Same as R81				
R363	Same as R249				
R364	Same as R104				
R365	Same as R46				
R366	Same as R194				
R367	Same as R10				
R368	Same as R249				
R369	Same as R194				
R370	Same as R40				
R371	Same as R10				
R372	Same as R95				
R373	Same as R2				
R374	Resistor, Fixed: 180Ω, 5%, 1/8 W	1	841296-047	14632	
T1	Transformer	1	841709-1	14632	
T2	Transformer	2	458DB-1011=P1	9AA39	
T3	Same as T2				
T4	Transformer	1	458PS-1007=T1	9AA39	

<i>REF DESIG</i>	<i>DESCRIPTION</i>	<i>QTY PER ASSY</i>	<i>MANUFACTURERS PART NO.</i>	<i>MFR. CODE</i>	<i>RECM VENDOR</i>
----------------------	--------------------	-----------------------------	-----------------------------------	----------------------	------------------------

REF DESIG PREFIX A3

U1	Integrated Circuit	1	8674HC08SO 14U	14632	
U2	Integrated Circuit	1	8674HC32SO 14U	14632	
U3	Integrated Circuit	1	8674HC138SO 16U	14632	
U4	Integrated Circuit/ CMOS	1	8674HC4094SO 16U	14632	
U5	Integrated Circuit	2	8674HC00SO 14U	14632	
U6	Amplifier	1	86062SO 8	14632	
U7	Integrated Circuit	3	MC145158DW -2	04713	
U8	Integrated Circuit	1	8674HC02SO 14U	14632	
U9	OSC/ TCVXO, ±0.6 PPM	1	92658	14632	
U10	Integrated Circuit/ CMOS	3	8674AC00SO 14U	04713	
U11	Integrated Circuit	1	TL431CD	04713	
U12	Same as U2				
U13	Integrated Circuit/ CMOS	1	MB87086APF	61271	
U14	Amplifer	10	NE5534D	18324	
U15	Same as U7				
U16	Same as U14				
U17	Integrated Circuit	1	MB504PF	61271	
U18	Integrated Circuit	1	SP8792/ MP	52648	
U19	Integrated Circuit/ CMOS	1	8674AC74S014	14632	
U20	Same as U5				
U21					
Thru	Same as U14				
U25					
U26	Mixer, Balanced	1	NE602D	18324	
U27	Same as U10				
U28	Integrated Circuit	1	SD5400CY	17856	
U29	Amplifier	1	IH2422AJ	27014	
U30	Mixer	1	IRMS-1-TR	15542	
U31	Integrated Circuit/ CMOS	1	8674HC4053SO 16U	14632	
U32	Same as U14				
U33	Integrated Circuit/ CMOS	1	8674AC86S014	14632	
U34	Same as U10				
U35	Same as U7				
U36	Same as U14				
U37	Integrated Circuit	1	8674HC74SO 14U	14632	
U38	Not Used				
U39	Amplifier	3	86061SO 08	14632	
U40	Same as U39				
U41	Same as U14				
VR1	Diode, Zener	2	MMBZ5231BLT1	04713	
VR2	Same as VR1				
VR3	Diode, Zener	1	MMBZ5235BLT1	04713	

FOLDOUTS

Courtesy of <http://BlackRadios.terryo.org>

THIS PAGE INTENTIONALLY LEFT BLANK

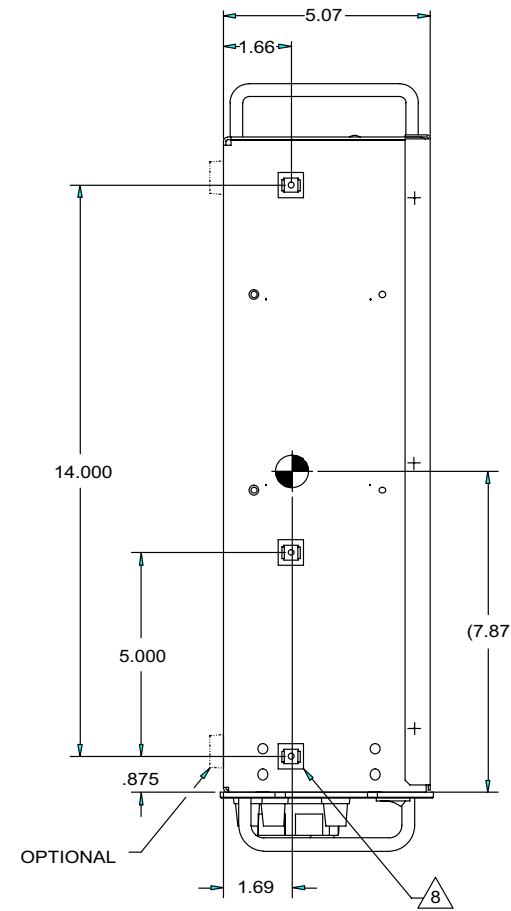
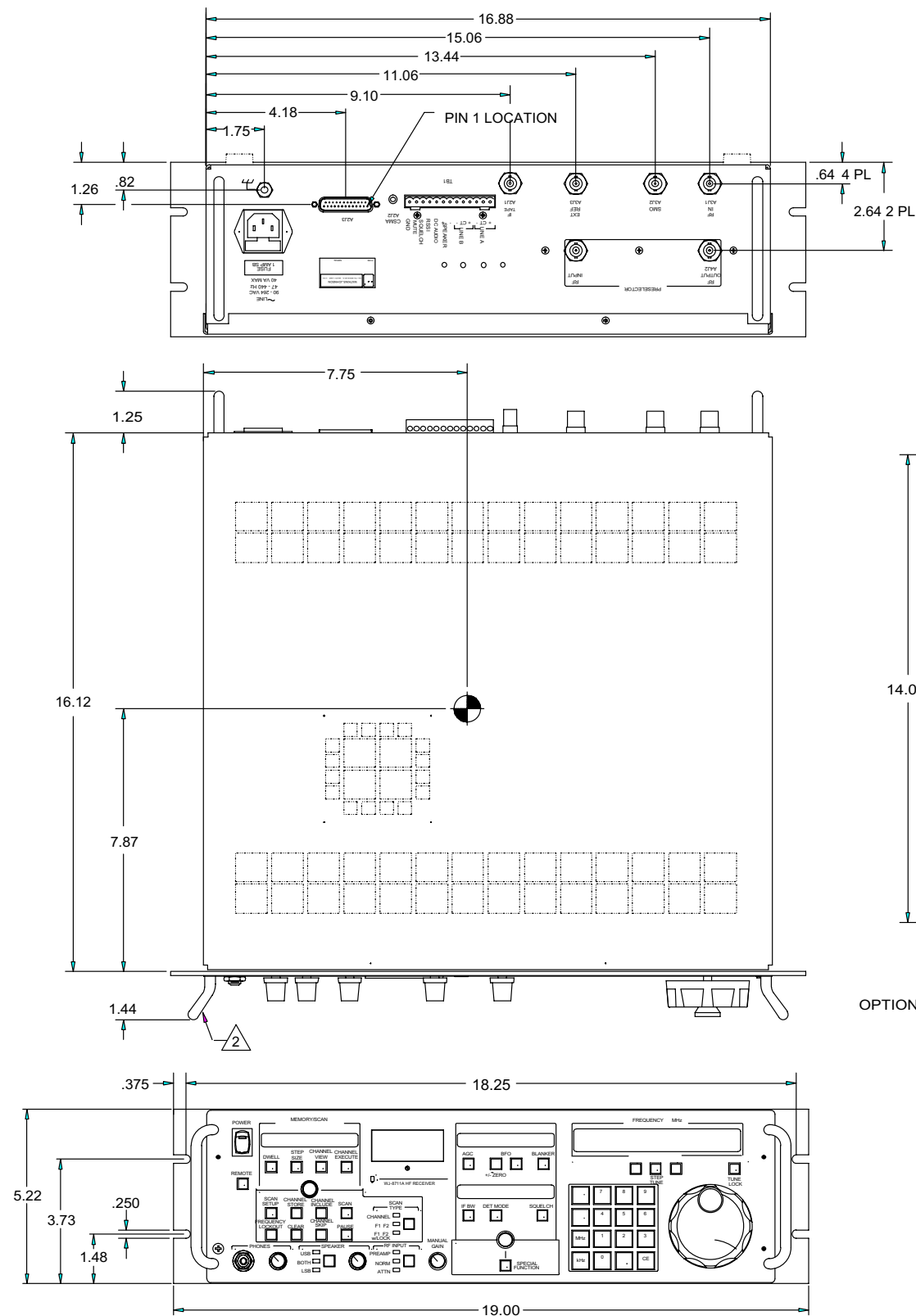

NOTES

1. POWER REQUIREMENTS:
INPUT POWER 40 WATTS MAXIMUM
INPUT VOLTAGE 90 TO 264 VAC
2. IDENTIFIES MAXIMUM PROTRUSION OF FRONT PANEL ITEMS.
3. THE EQUIPMENT WILL OPERATE IN A FREE AIR AMBIENT AT SEA LEVEL FROM -10°C TO +55°C WITH COMPLETE PERFORMANCE SPECIFICATIONS BEING MET FROM 0°C TO 50°C. WHERE THE ENVIRONMENT VARIES FROM FREE AIR AMBIENT AT SEA LEVEL SUFFICIENT AIR SPACE AND/OR VOLUME OF COOLING AIR MUST BE PROVIDED AROUND THE UNIT TO DISSIPATE THE HEAT DEVELOPED.
4. WEIGHT: 10.5 LBS. NOMINAL
5. CENTER OF GRAVITY IS APPROXIMATELY AT POINT IDENTIFIED BY
6. SLIDE (OPTIONAL) MANUFACTURED BY: JONATHAN MANUFACTURING CO. FULLERTON, CA 92632 MFR CODE 05236 PART NO. 110QD-16-2
7. IT IS SUGGESTED THAT THE FRONT PANEL BE SECURED TO THE RACK AS SHOWN IN DETAIL "A".
8. SLIDE MOUNTING HOLES TYPICAL BOTH SIDES.

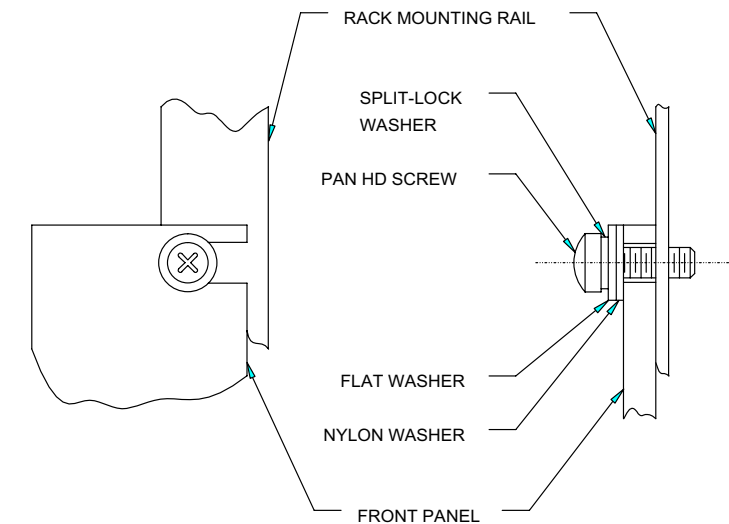

DETAIL A

871L122A

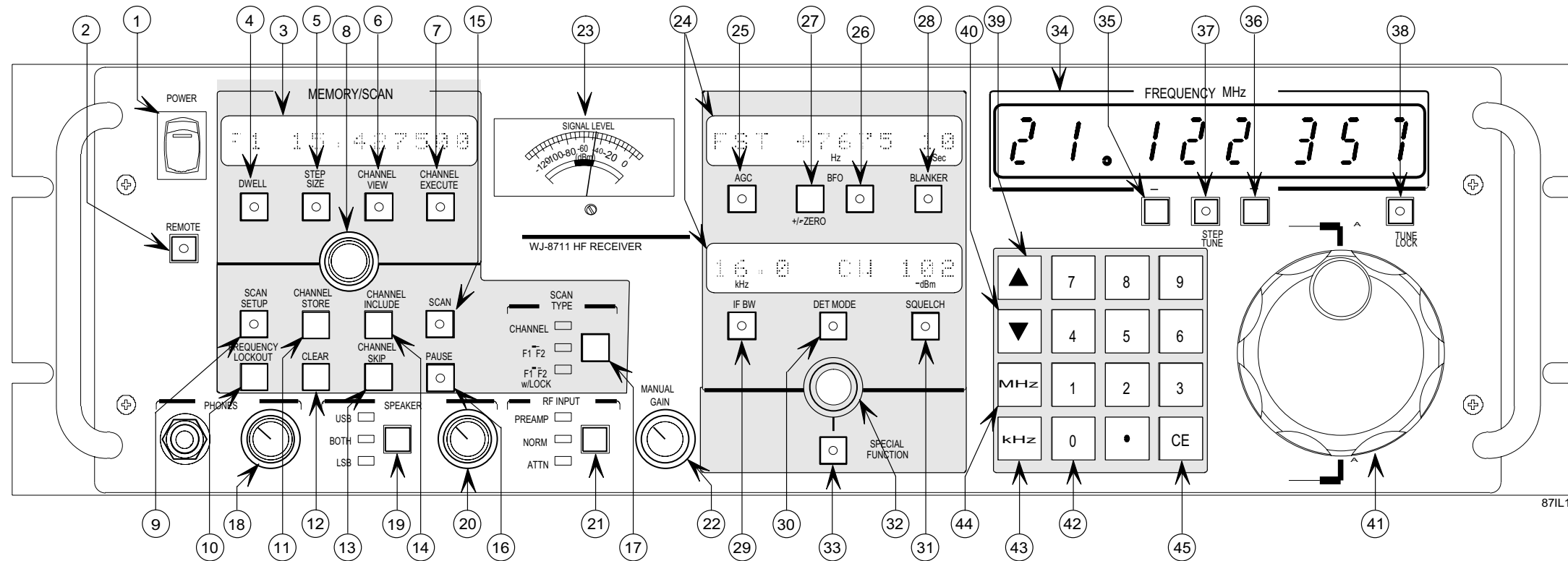

Item	Para. Ref.	Function	Item	Para. Ref.	Function	Item	Para. Ref.	Function	Item	Para. Ref.	Function
1	3.2.42	Turns receiver on and off.	13	3.2.31	Sets displayed channel to "skip" status for scans.	26	3.2.15	Enables adjustment of BFO frequency when lit and in CW detect mode.	38	3.2.2	Disables the tuning wheel and up and down arrow keys. Controls disabled when lit.
2	3.2.41	Places receiver in and out of Remote mode. LED lit when in Remote.	14	3.2.30	Sets displayed channel to "include" status for scans.	27	3.2.16	Sets displayed BFO frequency to positive, negative, or zero.	39	3.2.5	Increases tuned frequency by incrementing the highlighted digit or by the selected step size (in Step Tune mode).
3	3.2.20	Displays memory and scan functions.	15	3.2.32	Initiates scan mode. Scan mode active when lit.	28	3.2.17	Allows adjustment or noise blanking value when lit.	40	3.2.5	Decreased tuned frequency by decrementing the highlighted digit or by the selected step size (in Step Tune mode).
4	3.2.21	Enables entry of dwell time. Activated when lit.	16	3.2.33	Pauses or resumes an active scan. Scan paused when lit.	29	3.2.11	Allows selection of IF bandwidth when lit.	41	3.2.4	Increases or decreases tuned frequency by increasing or decreasing the highlighted digit or by the selected step size (Step Tune mode).
5	3.2.22	Enables entry of step size for tuned frequency and scan. Activated when lit.	17	3.2.23	Selects the scan type. Selection indicated by lit LED.	30	3.2.12	Allows selection of detection mode when lit.	42	3.2.6	These keys (0 through 9 and decimal point) allow for entering various numeric parameters.
6	3.2.23	Allows viewing of stored channel frequencies when lit.	18	3.2.35	Adjusts headphones volume.	31	3.2.13	Allows adjustment of squelch level when lit.	43	3.2.7	Terminates a numeric entry of tuned frequency, indicating kilohertz.
7	3.2.24	Tunes receiver to parameters of selected memory channel when lit.	19	3.2.36	Selects speaker audio for ISB mode. Selection indicated by lit LED.	32	3.2.19	Adjusts enabled auxiliary parameters or special function.	44	3.2.7	Terminates a numeric entry of tuned frequency, indicating megahertz.
8	3.2.34	Adjusts displayed memory or scan parameters.	20	3.2.37	Adjusts speaker volume.	33	3.2.18	Accesses passband tuning, remote configurations, and BITE functions.	45	3.2.8	Clears an in-progress, unterminated numeric entry.
9	3.2.26	Enables a scan setup entry for the selected scan type when lit.	21	3.2.38	Selects Path for RF input. Selection indicated by LED.	34	3.2.1	Displays current tuned frequency.			
10	3.2.27	Stores current receiver frequency into lockout memory.	22	3.2.39	Adjusts gain in manual gain mode.	35	3.2.3	Moves the frequency display cursor left.			
11	3.2.28	Stores current receiver parameters in the displayed memory channel.	23	3.2.40	Displays the signal strength of the current received signal.	36	3.2.3	Moves the frequency display cursor right.			
12	3.2.29	Clears displayed lockout frequency or blanks the Memory/Scan display. Clears all lock out and memory channels when pressed 3 times.	24	3.2.10	Displays auxiliary receiver parameters and special functions.	37	3.2.9	Selects the step tuning mode. Mode is activated when lit.			
			25	3.2.14	Enables selection of gain control mode (Fast or Slow AGC, or manual) when lit.						

1. STORING CHANNELS IN MEMORY

The following steps are an example of the procedure necessary to store parameters in a memory channel for use during a channel scan operation. Three memory channels are loaded with data: 10, 11, and 20. Channel 10 is stored first with parameters such as a 6 kHz IF bandwidth, AM detection mode, -95 dBm squelch level, the fast AGC mode, and a frequency of 1.5 MHz. Channel 11 is stored next and contains the same parameters as channel 10 except it has a frequency of 1.6 MHz. Channel 20 has the same parameters as channel 10 except its threshold is set at -80 dBm and has a frequency of 15 MHz.

PROCEDURE	CONTROL ACTIONS	DISPLAY REACTION	PROCEDURE	CONTROL ACTIONS	DISPLAY REACTION
A. Select the 6 kHz IF bandwidth by pressing the IF BW key and rotating the Auxiliary Parameter Edit Knob.	IF BW (AUX. PARAM. EDIT KNOB)	6.0 kHz AM --- -dBm			
B. Select the AM detection mode.	DET MODE (AUX. PARAM. EDIT KNOB)	6.0 kHz AM --- -dBm			
C. Set the squelch level to -95 dBm.	9 5 SQUELCH	6.0 kHz AM 095 -dBm			
D. Set the AGC to the fast mode.	AGC (AUX. PARAM. EDIT KNOB)	FST --- Hz			
E. Enter a frequency of 1.5 MHz. Then store the frequency and auxiliary parameters in Channel 10.	1 . 5 MHz 1 0 CHANNEL STORE	FREQUENCY MHz 1 . 500 000 MEMORY/SCAN i 10 01.500000 ↓ MEMORY/SCAN s 11 20.000000			
Storing a frequency in a channel automatically sets the channel to the include status as indicated by the "i" to the left of the channel number. Approximately one second after the frequency is stored in channel 10, the display automatically steps to channel 11.					
F. Enter a frequency of 1.6 MHz. Then store the frequency and current auxiliary parameters in Channel 11.	1 . 6 MHz CHANNEL STORE	FREQUENCY MHz 1 . 600 000 MEMORY/SCAN i 11 01.600000 ↓ MEMORY/SCAN s 12 20.000000			
G. Reset the squelch level to -80 dBm.	8 0 SQUELCH	6.0 kHz AM 080 -dBm			
H. Enter a frequency of 15 MHz. Then store the frequency and auxiliary parameters in Channel 20.	1 5 MHz 2 0 CHANNEL STORE	FREQUENCY MHz 15 . 000 000 MEMORY/SCAN i 20 15.000000 ↓ MEMORY/SCAN s 21 20.000000			

2. SET UP THE CHANNEL SCAN OPERATION

The following steps are an example of the procedure necessary to set up the receiver for a channel scan operation. In the example, Channel 10 is selected as the start channel and Channel 20 is selected as the stop channel. The dwell time is set to 3.5 seconds. In this setup, Channels 10, 11, and 20 are visited in the scan and Channels 00 thru 19, and 21 thru 99 are skipped.

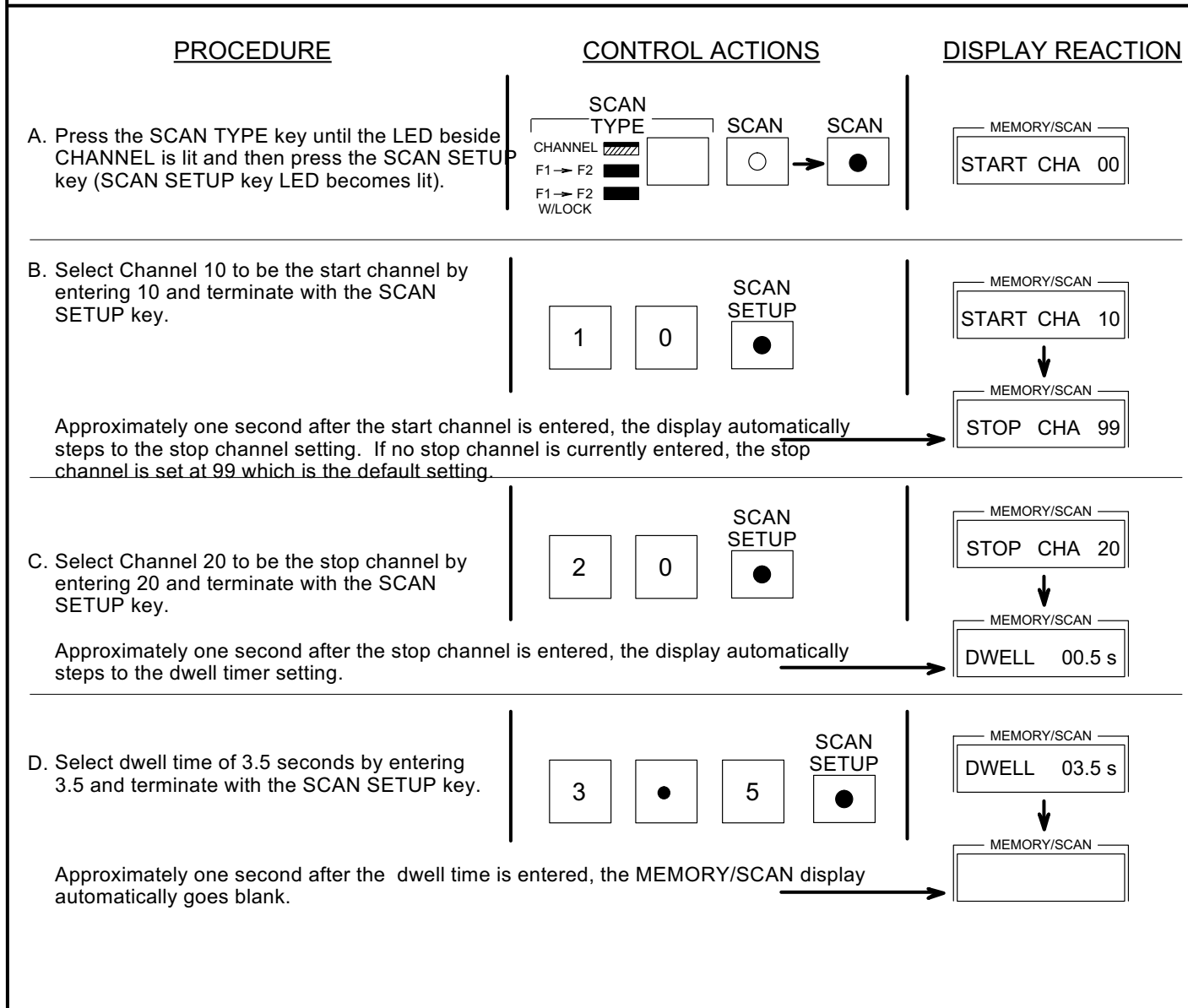

3. EXECUTING THE CHANNEL SCAN OPERATION

The following steps are an example of the procedure necessary to execute a channel scan. The first step initiates the channel view mode (optional). The scan is then started.

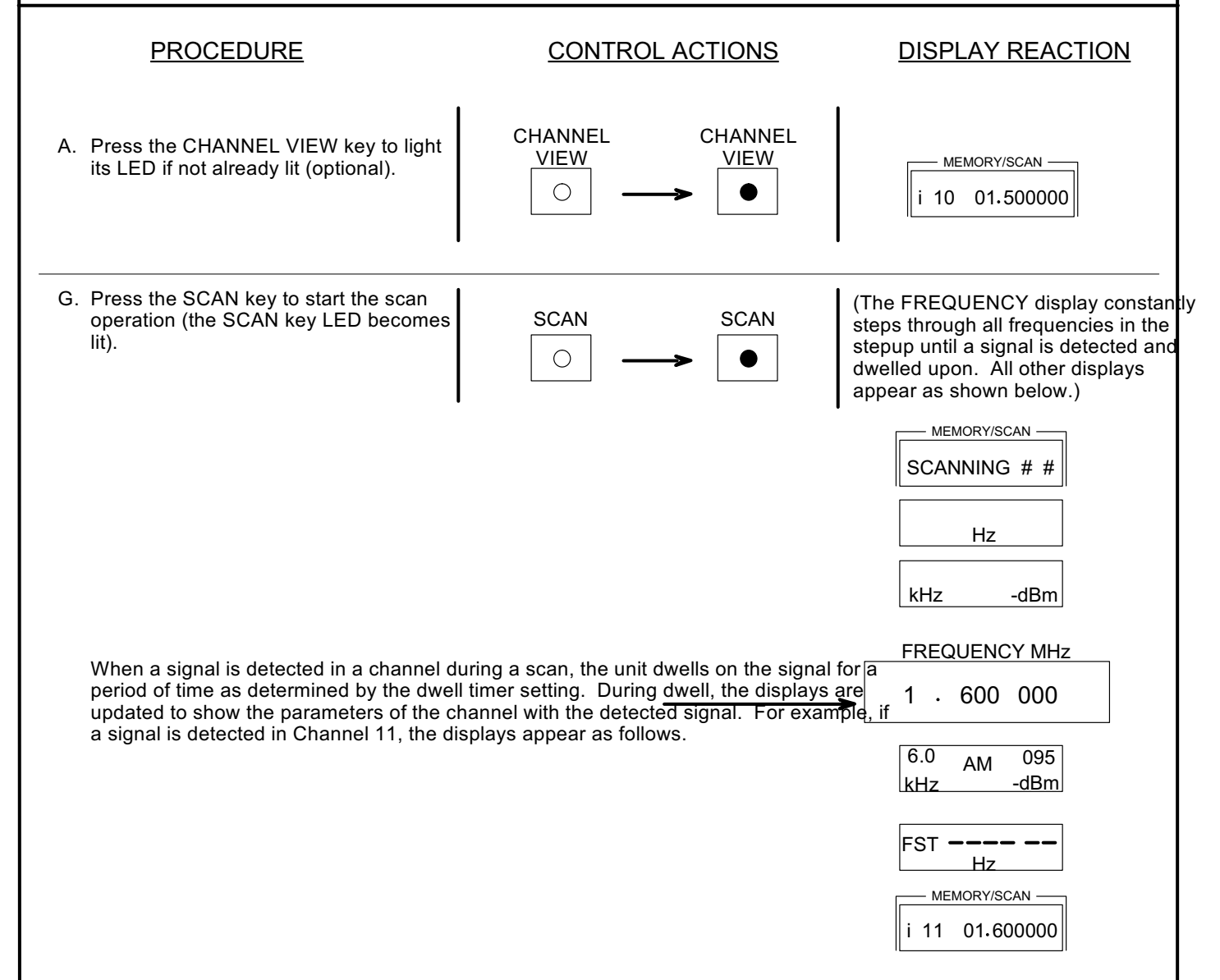

4. SKIPPING A CHANNEL DURING CHANNEL SCAN EXECUTION

The following steps are an example of the procedure necessary to skip a channel during channel scan. The first step pauses the scan. The next steps select Channel 20 to be viewed and set to the skip status. The scan is then restarted.

PROCEDURE	CONTROL ACTIONS	DISPLAY REACTION
A. Press the PAUSE key to stop the scan. The PAUSE key LED should become lit; if the CHANNEL VIEW key LED is not lit, press the key so its LED becomes lit.		(The displays show the parameters of the channel that was accessed when the scan was stopped.)
B. Select Channel 20 by entering 20 and terminate with the CHANNEL VIEW key.		
C. Lockout Channel 20 by pressing the CHANNEL SKIP key.		
D. Restart the scan operation by pressing the PAUSE key.		

5. INCLUDING A CHANNEL DURING CHANNEL SCAN EXECUTION

The following steps are an example of the procedure necessary to include a channel during channel scan. The first step pauses the scan. The next steps select Channel 20 to be viewed and set to the include status. The scan is then restarted.

PROCEDURE	CONTROL ACTIONS	DISPLAY REACTION
A. Press the PAUSE key to stop the scan. The PAUSE key LED should become lit; if the CHANNEL VIEW key LED is not lit, press the key so its LED becomes lit.		(The displays show the parameters of the channel that was accessed when the scan was stopped.)
B. Select Channel 20 by entering 20 and terminate with the CHANNEL VIEW key.		
C. Set Channel 20 to the include status by pressing the CHANNEL INCLUDE key.		
D. Restart the scan operation by pressing the PAUSE key.		

871L124B

1. SET UP THE F1 → F2 SCAN

The following steps are an example of the procedure necessary to set up an F1 → F2 scan. In the example, the scan is set up with a start frequency of 530 kHz, a stop frequency of 1.6 MHz, a step size of 10 kHz, and a dwell time of 3 seconds.

PROCEDURE	CONTROL ACTIONS	DISPLAY REACTION
A. Press the SCAN TYPE key until the LED beside F1 → F2 is lit and then press the SCAN SETUP key (SCAN SETUP key LED becomes lit).		
B. Reset the start frequency to 0.53 MHz by entering .53 and terminate with the SCAN SETUP key. Approximately one second after the start frequency is entered, the display automatically steps to the default or previously set stop frequency setting.		
C. Reset the stop frequency to 1.6 MHz by entering 1.6 and terminate with the SCAN SETUP key. Approximately one second after the stop frequency is entered, the display automatically steps to the default or previously set step size setting.		
D. Enter a step size of 10 kHz by entering 10 and terminate with the SCAN SETUP key. Approximately one second after the step size is entered, the display automatically steps to the dwell timer setting.		
E. Select a dwell time of 3 seconds by entering 3 and terminate with the SCAN SETUP key. Approximately one second after the dwell time is entered, the scan setup mode is automatically exited and the MEMORY/SCAN display goes blank.		

2. EXECUTING THE F1 → F2 SCAN

The following steps are an example of the procedure necessary to execute an F1 → F2 scan. In the example, the auxiliary parameters of the receiver are set first, such as selecting the 6 kHz IF bandwidth, AM detection mode, -95 dBm squelch level, and the fast AGC mode. Then the scan is started. Steps are also given to pause the scan, reset the squelch level to -90 dBm, and then resume the scan. The last step shows how to stop and exit the scan mode.









PROCEDURE	CONTROL ACTIONS	DISPLAY REACTION
A. Select the 6 kHz IF bandwidth.		
B. Select the AM detection mode.		
C. Set the squelch level to -95 dBm.		
D. Set the AGC to the fast mode.		
E. Press the SCAN TYPE key until the LED beside F1 → F2 is lit and then press the SCAN key to start the scan (SCAN key LED becomes lit).		<p>(The FREQUENCY display constantly steps through all frequencies in the setup until a signal is detected and dwelled upon.)</p>
F. Press the PAUSE key to pause the scan (PAUSE key LED becomes lit).		<p>(The FREQUENCY display shows the tuned frequency.)</p>
G. Reset the squelch level to -90 dBm.		
H. Press the PAUSE key to restart the scan.		<p>(The FREQUENCY display constantly steps through all frequencies in the setup until a signal is detected and dwelled upon.)</p>
I. Press the SCAN key to stop the scan.		<p>(The FREQUENCY display shows the tuned frequency.)</p>

NOTE: The MEMORY SCAN EDIT KNOB can be used in the above example to jump back and forth between scan setup parameters.

871L125



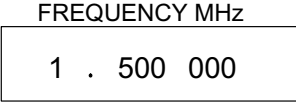
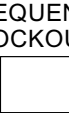
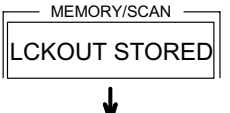
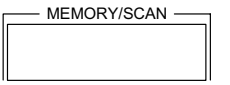
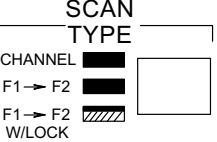



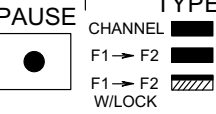

3. LOCKING A FREQUENCY OUT OF THE F1 → F2 SCAN

The following steps are an example of the procedure necessary to lock a frequency out of an F1 → F2 scan. The first step pauses the scan. Then enter the frequency of 1.5 MHz to be locked out and press the FREQUENCY LOCKOUT key to store it. The last steps restart the scan.

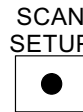
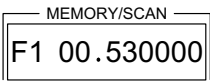
PROCEDURE	CONTROL ACTIONS	DISPLAY REACTION
A. Press the PAUSE key to pause the scan (PAUSE key LED becomes lit).	 → 	(The FREQUENCY display shows the current frequency.)
B. Enter a frequency of 1.5 MHz by entering 1.5 and terminate with the MHz key	   	
C. With a frequency of 1.5 MHz currently shown in the frequency display, press the FREQUENCY LOCKOUT key to lock it out of the scan operation. Approximately one second after the lockout frequency is entered the Memory/Scan display automatically goes blank.		 ↓ 
D. Press the SCAN TYPE key until the LED beside F1 → F2 w/Lock is lit.		(No reaction from the displays.)
E. Press the PAUSE key to restart the scan.	 → 	(The FREQUENCY display constantly steps through all frequencies in the setup until a signal is detected and dwelled upon.)

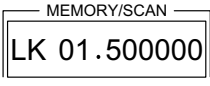
4. VIEWING AND CLEARING A LOCKOUT FREQUENCY

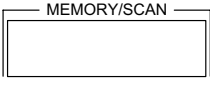
The following steps are an example of the procedure necessary to view and clear stored lockout frequencies. The first step pauses the scan and selects the F1 → F2 w/Lock mode so the lockouts can be viewed. Then the scan setup parameters and lockout frequencies are viewed. With the lockout frequency of 1.5 MHz displayed, it is then cleared and the scan is restarted.

PROCEDURE	CONTROL ACTIONS	DISPLAY REACTION
A. Press the Pause key to pause the scan (PAUSE key LED becomes lit) and then press the SCAN TYPE key until the LED beside F1 → F2 w/Lock is lit.	 → 	(The FREQUENCY display shows the tuned frequency.)
B. Select the SCAN SETUP key to light its LED if not already lit.	 → 	
C. Continue pressing the SCAN setup key or use the MEMORY/SCAN EDIT KNOB to step through and view the start frequency, stop frequency, step size, and dwell timer settings and then the stored lockout frequency(s).	 OR 	
D. With the undesired lockout frequency shown in the MEMORY/SCAN display, press the CLEAR key to clear it from memory.		
E. Press the PAUSE key to restart the scan.	 → 	(The FREQUENCY display constantly steps through all frequencies in the setup until a signal is detected and dwelled upon.)

871L125A

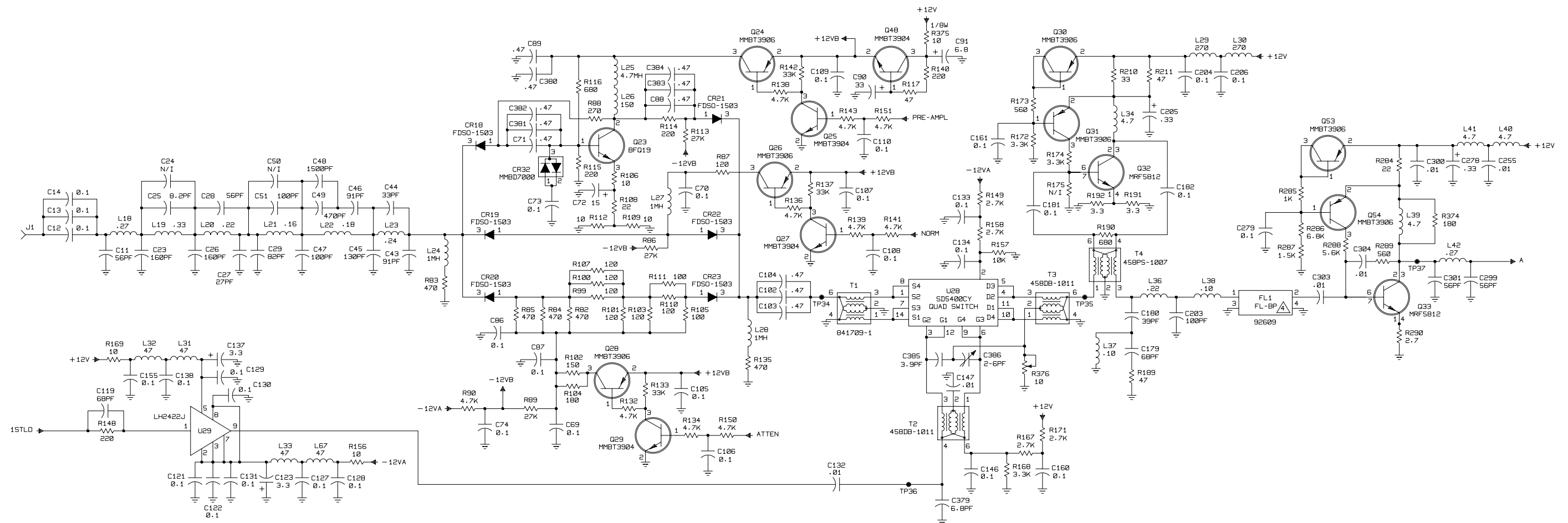

NOTES:

1. UNLESS OTHERWISE SPECIFIED:
 A) RESISTANCE IS IN OHMS, $\pm 5\%$, 1/10W.
 B) CAPACITANCE IS IN μ F.
 C) INDUCTANCE IS IN μ H.
2. PADDLE-STRIP 'E1' HAS A PLUG LABELED 'P1' (NOT-SHOWN) WITH IDENTICAL PINS.
- ③ -3 AND -4 ARE CONFORMAL COATED VERSIONS OF -1 AND -2, RESPECTIVELY.
- ④ SEE TABLE 'A' FOR DIFFERENCE BETWEEN DASH NUMBERS.
- ⑤ NOMINAL VALUE, FINAL VALUE FACTORY SELECTED.

TABLE A

TYPE (DASH) NO.	U9	FL1
797006-1	92658	92609
797006-2	92549	92609
797006-3		③
797006-4		
797006-5	92698	92699
797006-6	92658	92727
797006-7	92658	92727

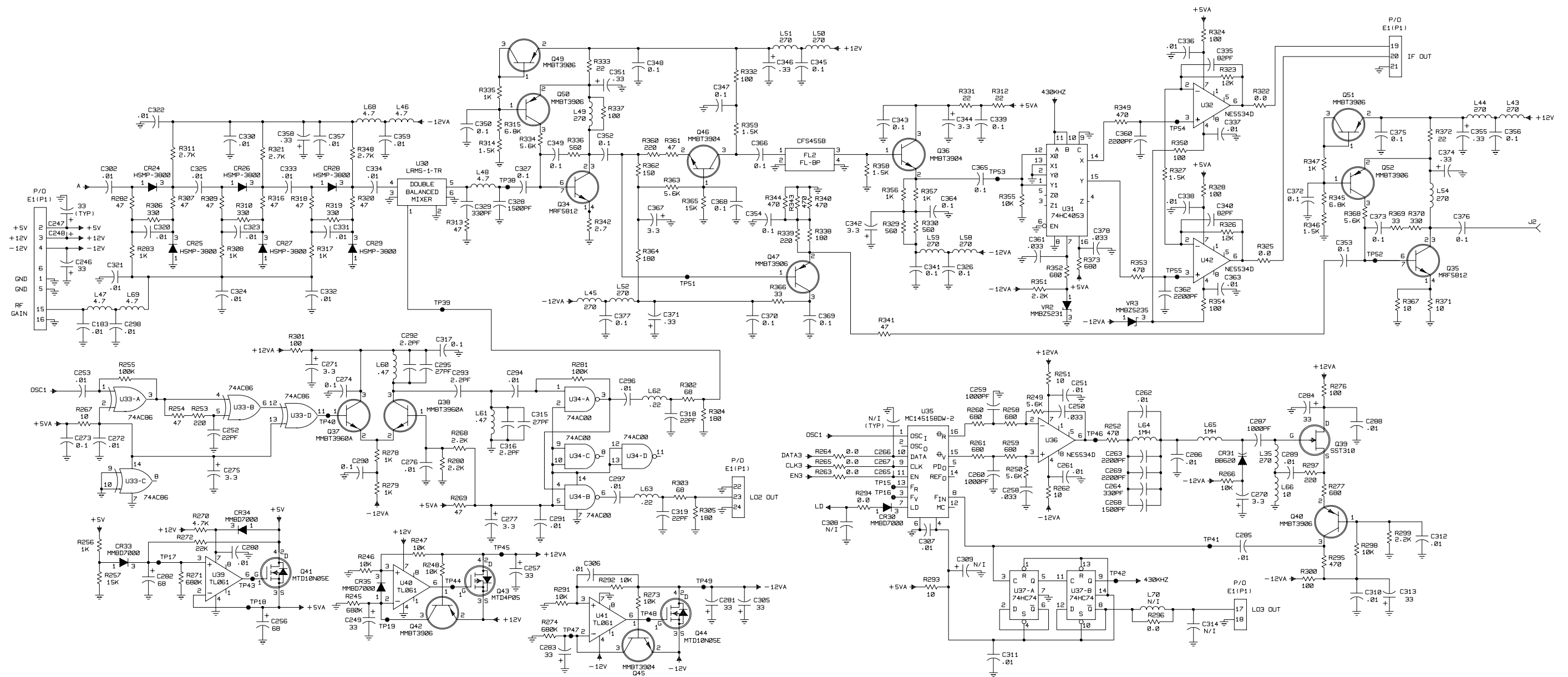

FO-5. Type 797006-X RF Tuner Assembly (A3),
Schematic Diagram 581274 (Sheet 2 of 3) (V)
FP-17/(FP-18 blank)

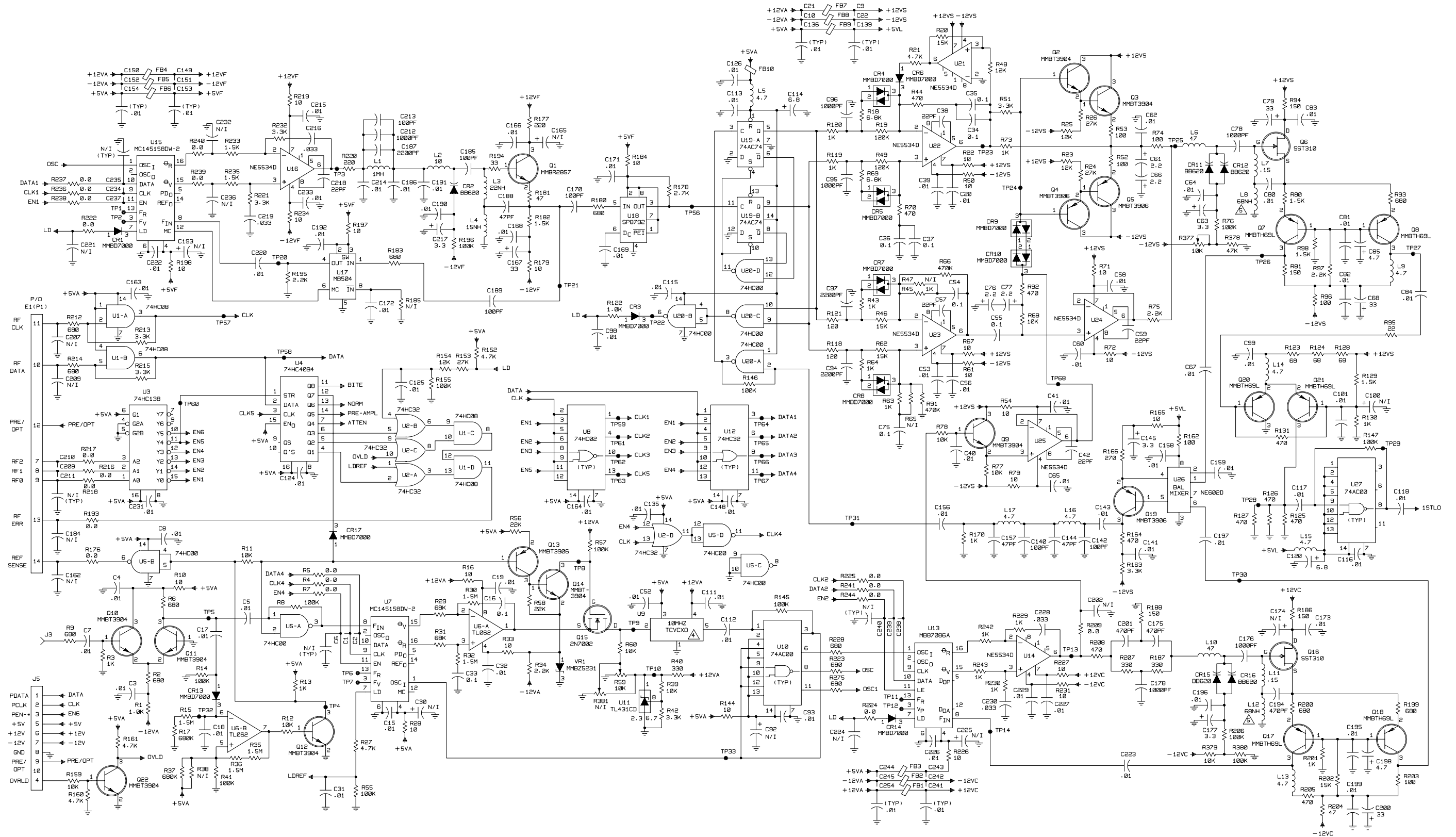

FO-5. Type 797006-X RF Tuner Assembly (A3),
Schematic Diagram 581274 (Sheet 3 of 3) (V)
FP-19/(FP-20 blank)

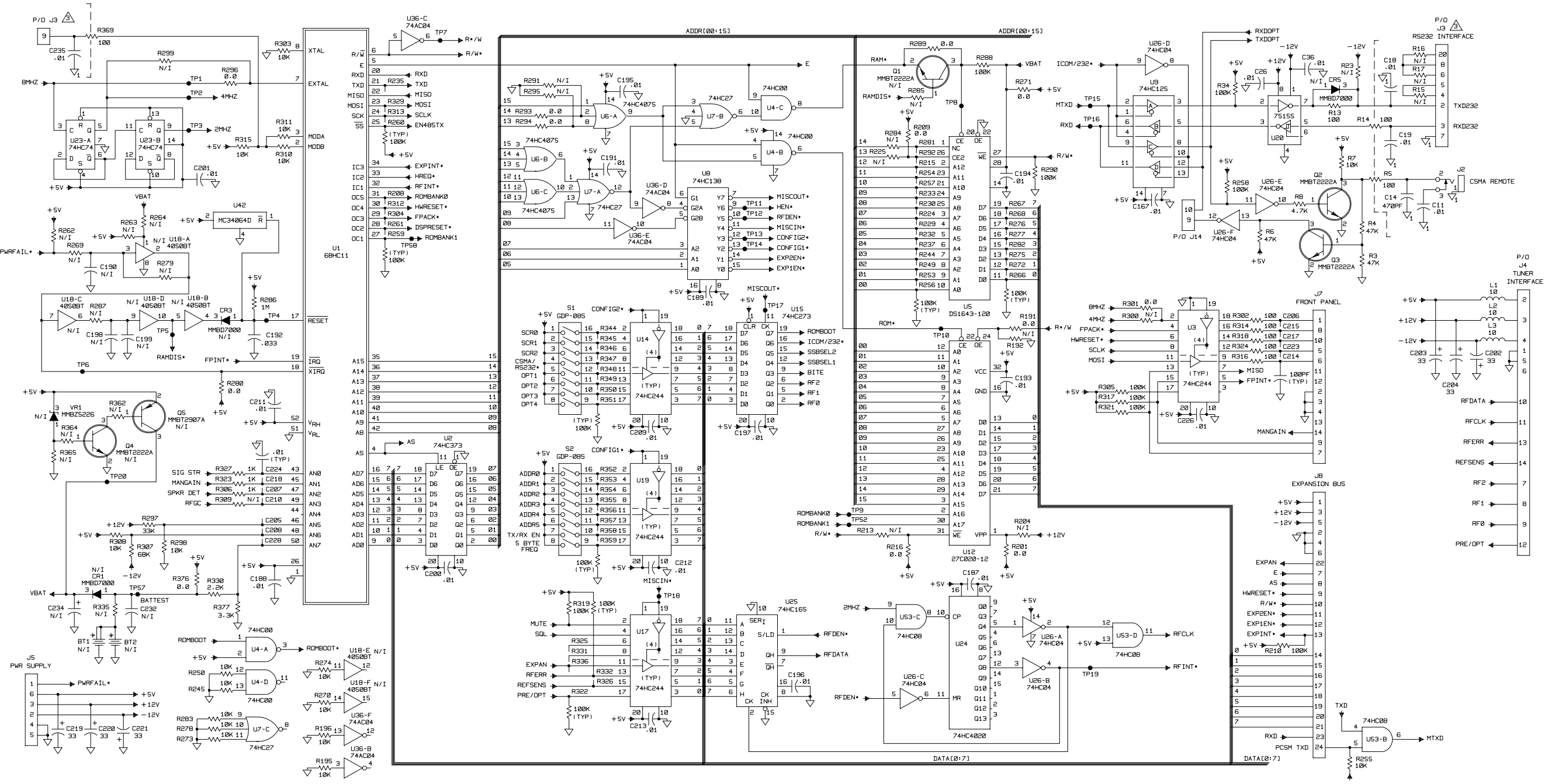

NOTES:

- UNLESS OTHERWISE SPECIFIED:
 - A) RESISTANCE IS IN OHMS, ±5% 1/10W.
 - B) CAPACITANCE IS IN µF.
 - C) INDUCTANCE IS IN µH.
- PIN/ADDRESS NUMBERS SHOWN ARE FOR MICRON SEMICONDUCTOR PARTS. ADDRESS NUMBERS MAY DIFFER ON ALTERNATE MFG. PARTS, HOWEVER THEY ARE FUNCTIONALLY EQUIVALENT.
- DIFFERENCE BETWEEN TYPES IS LISTED IN TABLE 1.

TABLE 1

TYPE	J3	J2
797214-1	USED	USED
797214-2	N/I	USED
797214-3	USED	N/I
797214-4	△	
797214-5	△	
797214-6	△	
797214-7	△	

NOTES: (CONTINUED)

- IT IS POSSIBLE TO USE VARIOUS DENSITY MEMORY CHIPS FOR U39,U40,U41,U45, U46,U47 & U56. THE FOLLOWING TABLE 2 LISTS EACH ASSY DASH NO. (TYPE). IT'S MEMORY CONFIGURATION, AND WHICH 0-OHM RESISTORS MUST BE INSTALLED.

TABLE 2

TYPE	REF DES	DESCRIPTION	PART NO.	R43	R44	R38	R156
U36	64K X 8 EPROM	27C512					
U45,U46,U47, U39,U48,U41	32K X 8 SRAM **	MT5C2568		0.0	N/I	0.0	N/I
	32K X 8 SRAM ***	MT5C2568					

** A 28-PIN 32K X 8 SRAM IS SHOWN ON THE SCHEMATIC. WHEN A 28-PIN 8K X 8 SRAM IS INSTALLED, PIN 26 IS CE2 (VS. A13) AND PIN 1 IS NC (VS. 141).

*** A32-PIN 128K X 8 SRAM IS SHOWN ON THE SCHEMATIC. WHEN A 28-PIN 32K X 8 IS INSTALLED, PINS 1 THRU 28 CORRESPOND TO PINS 3 THRU 30 ON THE 32-PIN CHIP.

△ -4 SAME AS -1, EXCEPT CONFORMAL COATED.

△ CUSTOMER SPECIFIC ALTERATIONS MADE. SEE 797214-5 CPL.

△ -6 SAME AS -1, EXCEPT SHIELD (383805-1) IS NOT INSTALLED OVER TB1.

△ -7 SAME AS -3, EXCEPT SHIELD (383805-1) IS NOT INSTALLED OVER TB1.

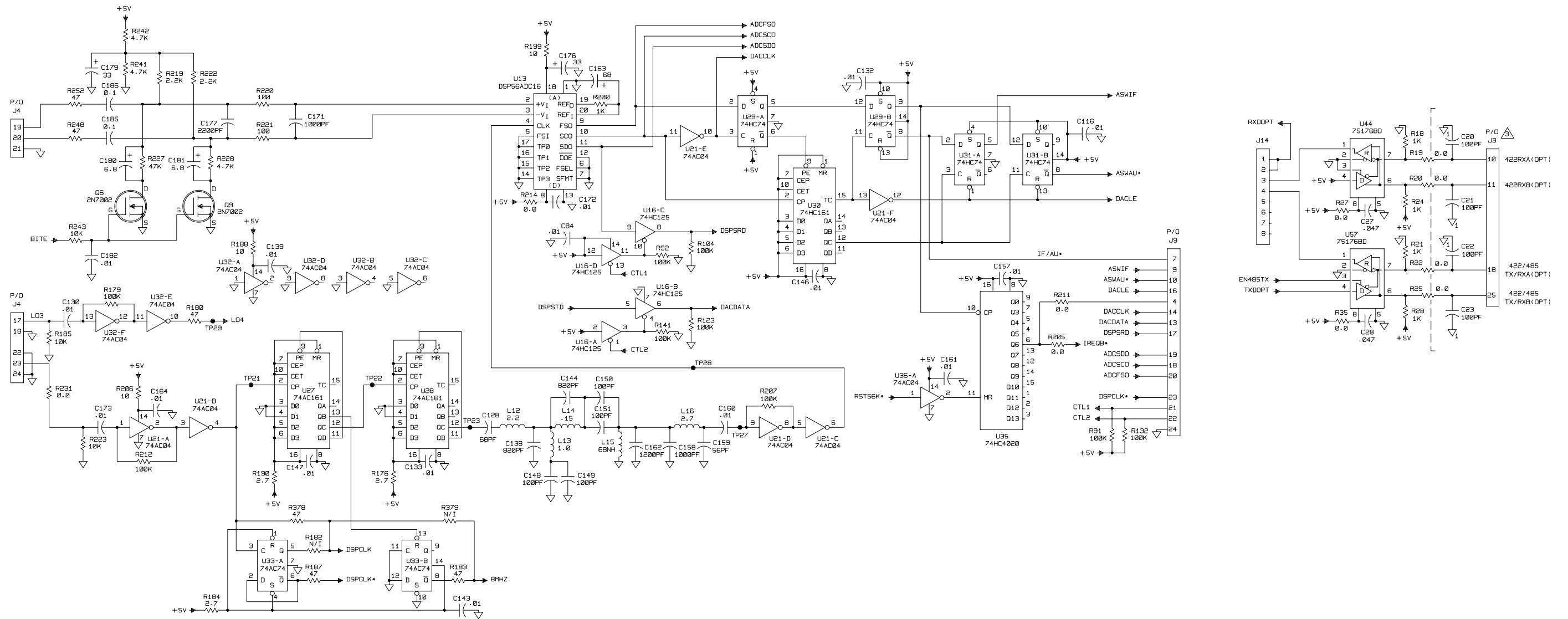

FO-6. Type 797214-1 Digital Control Assembly (A2), Schematic Diagram 581839 (Sheet 2 of 4) (F) FP-23/(FP-24 blank)

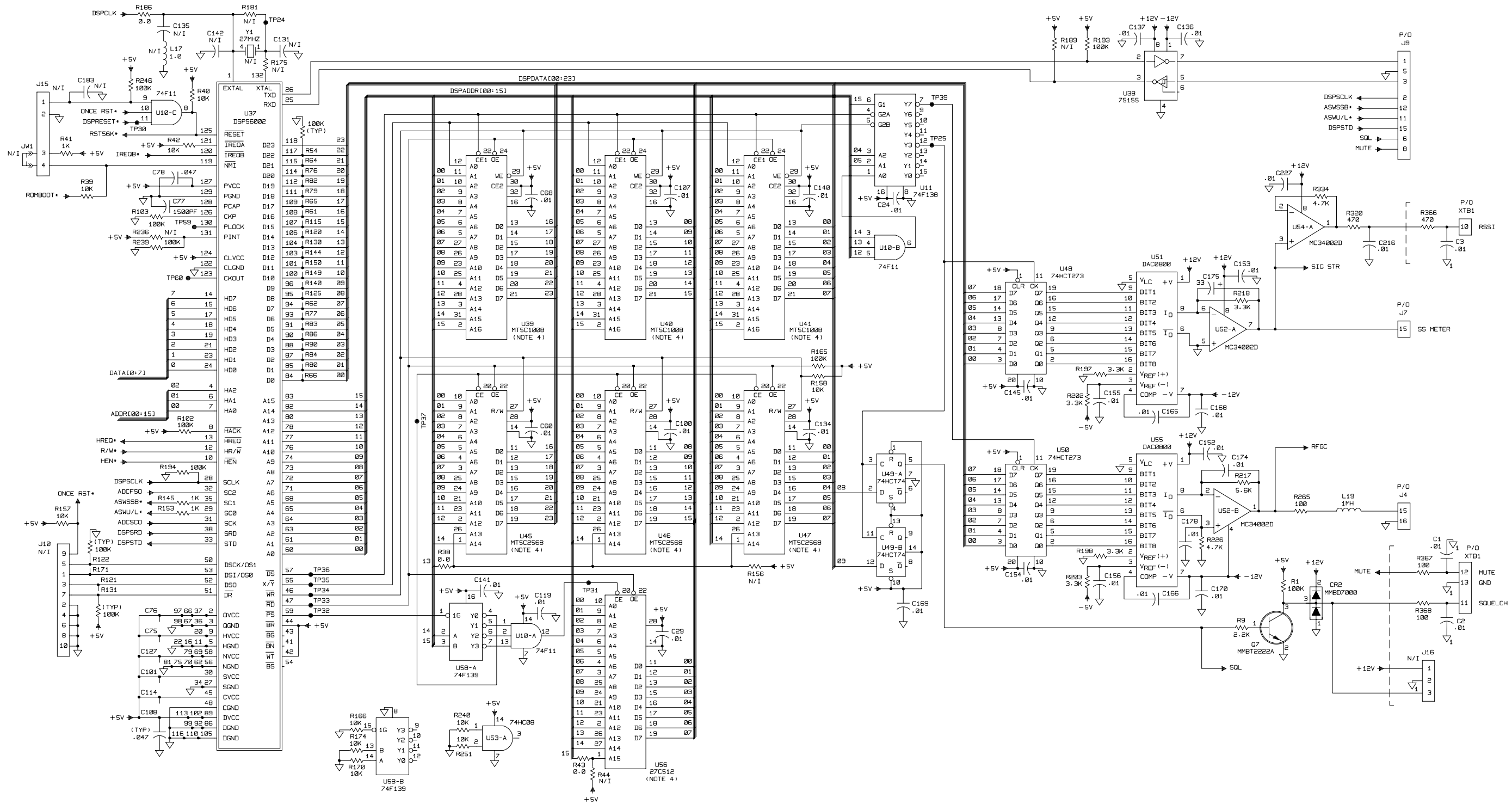

FO-6. Type 797214-1 Digital Control Assembly (A2),
Schematic Diagram 581839 (Sheet 3 of 4) (F)
FP-25/(FP-26 blank)

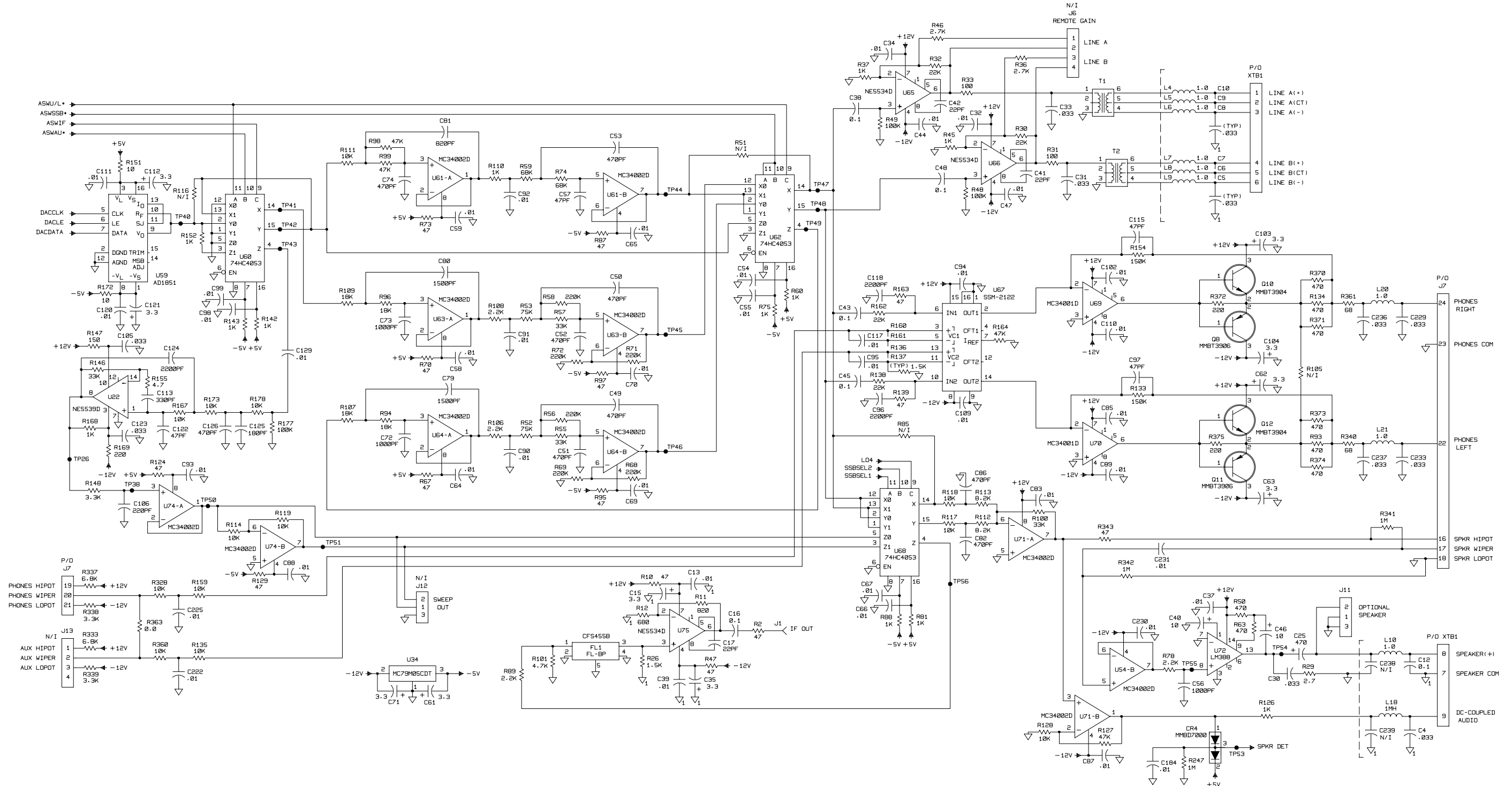

FO-6. Type 797214-1 Digital Control Assembly (A2),
Schematic Diagram 581839 (Sheet 4 of 4) (F)
FP-27/(FP-28 blank)

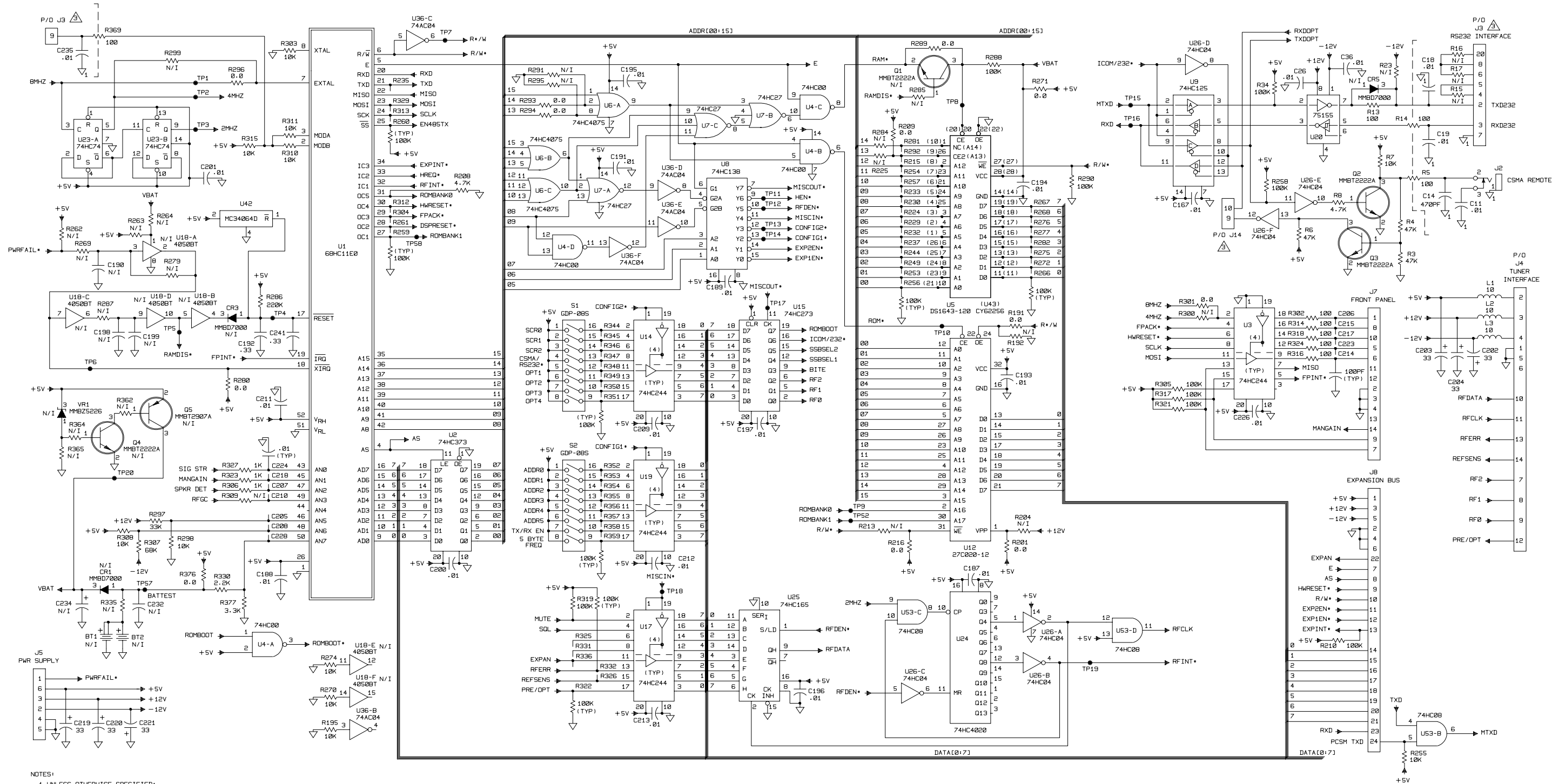

- NOTES:
- UNLESS OTHERWISE SPECIFIED:
 - A) RESISTANCE IS IN OHMS, $\pm 5\%/10\%$.
 - B) CAPACITANCE IS IN μF .
 - C) INDUCTANCE IS IN μH .
 - PIN/ADDRESS NUMBERS SHOWN ARE FOR MICRON SEMICONDUCTOR PARTS. ADDRESS NUMBERS MAY DIFFER ON ALTERNATE MFG. PARTS. HOWEVER THEY ARE FUNCTIONALLY EQUIVALENT.
 - DIFFERENCE BETWEEN TYPES IS LISTED IN TABLE 1.
 - IT IS POSSIBLE TO USE VARIOUS DENSITY MEMORY CHIPS FOR U3, U4, U11, U12, U13, U14, U15, U16, U17, U18, U19, U20, U21, U22, U23, U24, U25, U26, U27, U28, U29, U30, U31, U32, U33, U34, U35, U36, U37, U38, U39, U40, U41, U42, U43, U44, U45, U46, U47, U48, U49, U50, U51, U52, U53, U54, U55, U56, U57, U58, U59, U60, U61, U62, U63, U64, U65, U66, U67, U68, U69, U70, U71, U72, U73, U74, U75, U76, U77, U78, U79, U80, U81, U82, U83, U84, U85, U86, U87, U88, U89, U90, U91, U92, U93, U94, U95, U96, U97, U98, U99, U100. TABLE 2 LISTS EACH ASSY DASH NO. (TYPE); IT'S MEMORY CONFIGURATION, AND WHICH 0-OHM RESISTORS MUST BE INSTALLED.
 - BOMs 797214-005 AND 904978-005 DO NOT EXIST.

TABLE 1

TYPE	DESCRIPTION	J2	J3, J14	U14 JUMPER
904978-1	RS-232/CSMA	USED	USED	9-10
904978-2	IEEE-488	USED	N/I	N/I
904978-3	RS-232/RS-485	N/I	USED	2-4
904978-4	SAME AS -001 EXCEPT CONFORMAL COATED	USED	USED	S/A -001
904978-5	CUSTOMER SPECIFIC ALTERATIONS MADE. SEE 797214-005 CRL.			S/A -001
904978-6	SAME AS -001 EXCEPT 383805-001 SHIELD IS NOT INSTALLED OVER TB1.	N/I	USED	S/A -001
904978-7	SAME AS -003 EXCEPT 383805-001 SHIELD IS NOT INSTALLED OVER TB1.	N/I	USED	S/A -003
904978-8	S/A -001 EXCEPT 383805-001 SHIELD AND TB1 (644550) N/I. CONFORMAL COATED.	USED	USED	S/A -001

TABLE 2

TYPE	REF DES	DESCRIPTION	PART NO.	R43	R44	R38	R156
904978-1..-2	U6	64K X 8 EPROM	27C512	0.0	N/I	0.0	N/I
	U45, U46, U47, U33, U40, U41	32K X 8 SRAM **	MT5C2568	0.0	N/I	0.0	N/I
		32K X 8 SRAM ***	MT5C2568	0.0	N/I	0.0	N/I

** A 28-PIN 32K X 8 SRAM IS SHOWN ON THE SCHEMATIC. WHEN A 28-PIN 6K X 8 SRAM IS INSTALLED, PIN 26 IS CE2 (VS. A13) AND PIN 1 IS NC (VS. 141).

*** A32-PIN 128K X 8 SRAM IS SHOWN ON THE SCHEMATIC. WHEN A 28-PIN 32K X 8 IS INSTALLED, PINS 1 THRU 28 CORRESPOND TO PINS 3 THRU 30 ON THE 32-PIN CHIP.

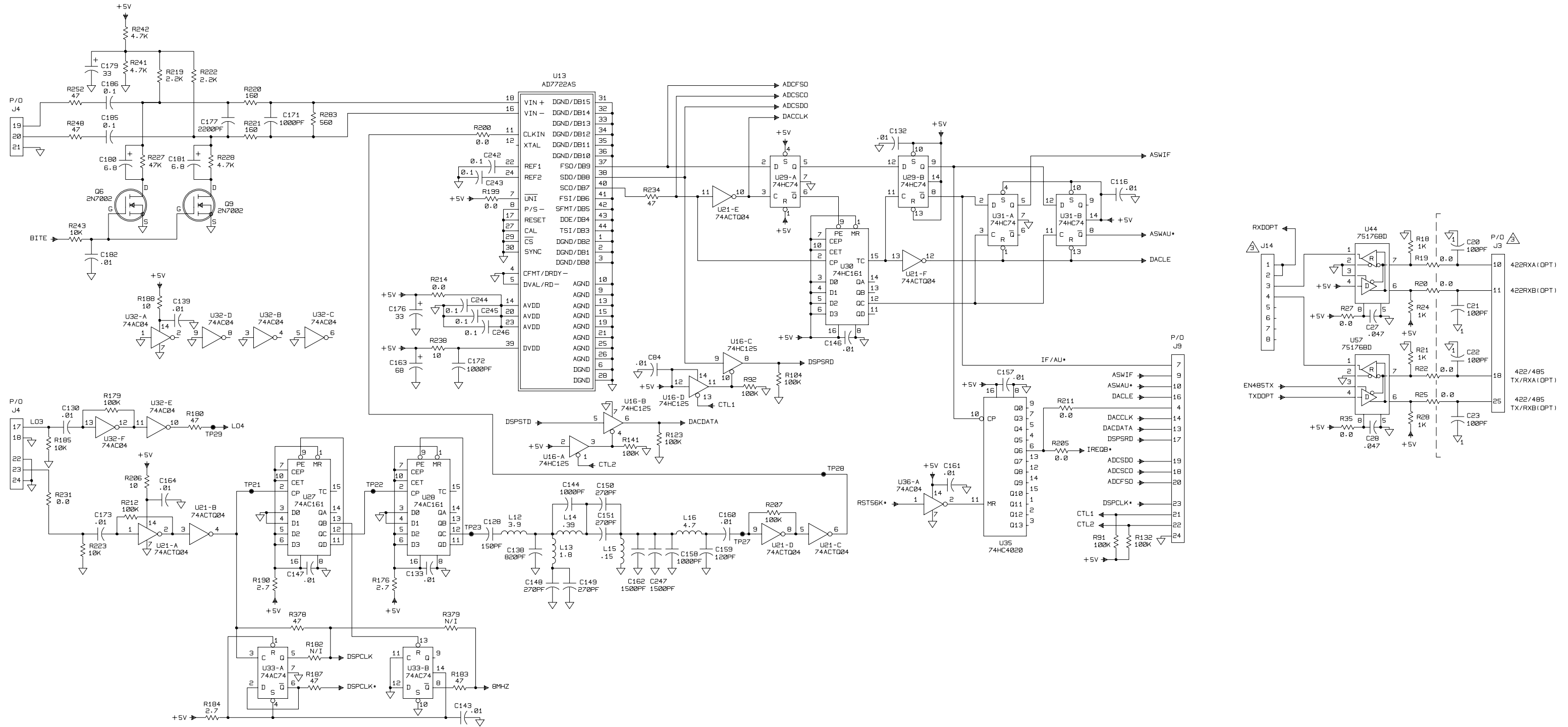

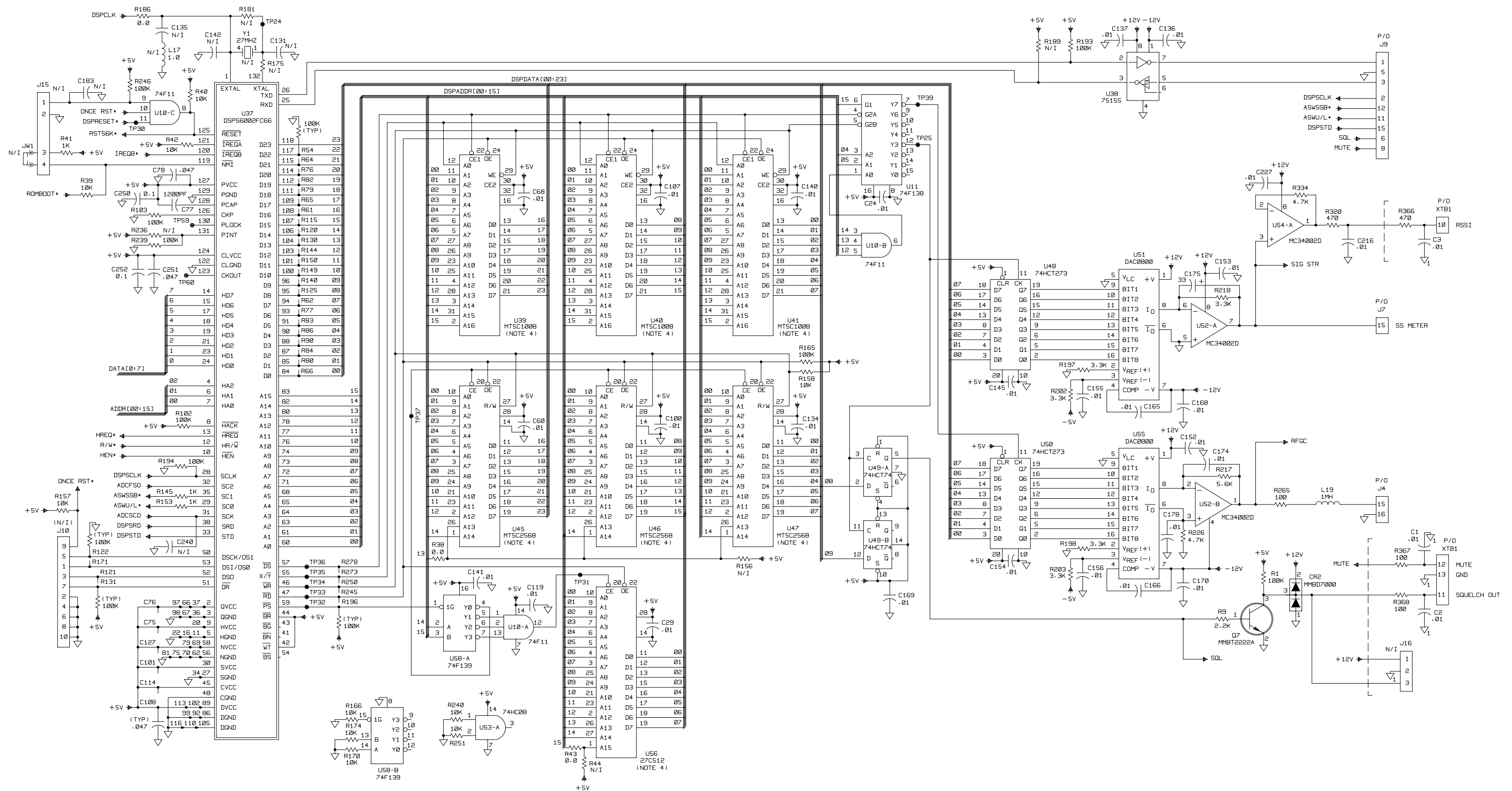

FO-6A. Type 904978-1 Digital Control Assembly (A2),
Schematic Diagram 904981 (Sheet 3 of 4) (D)
FP-33/(FP-34 blank)

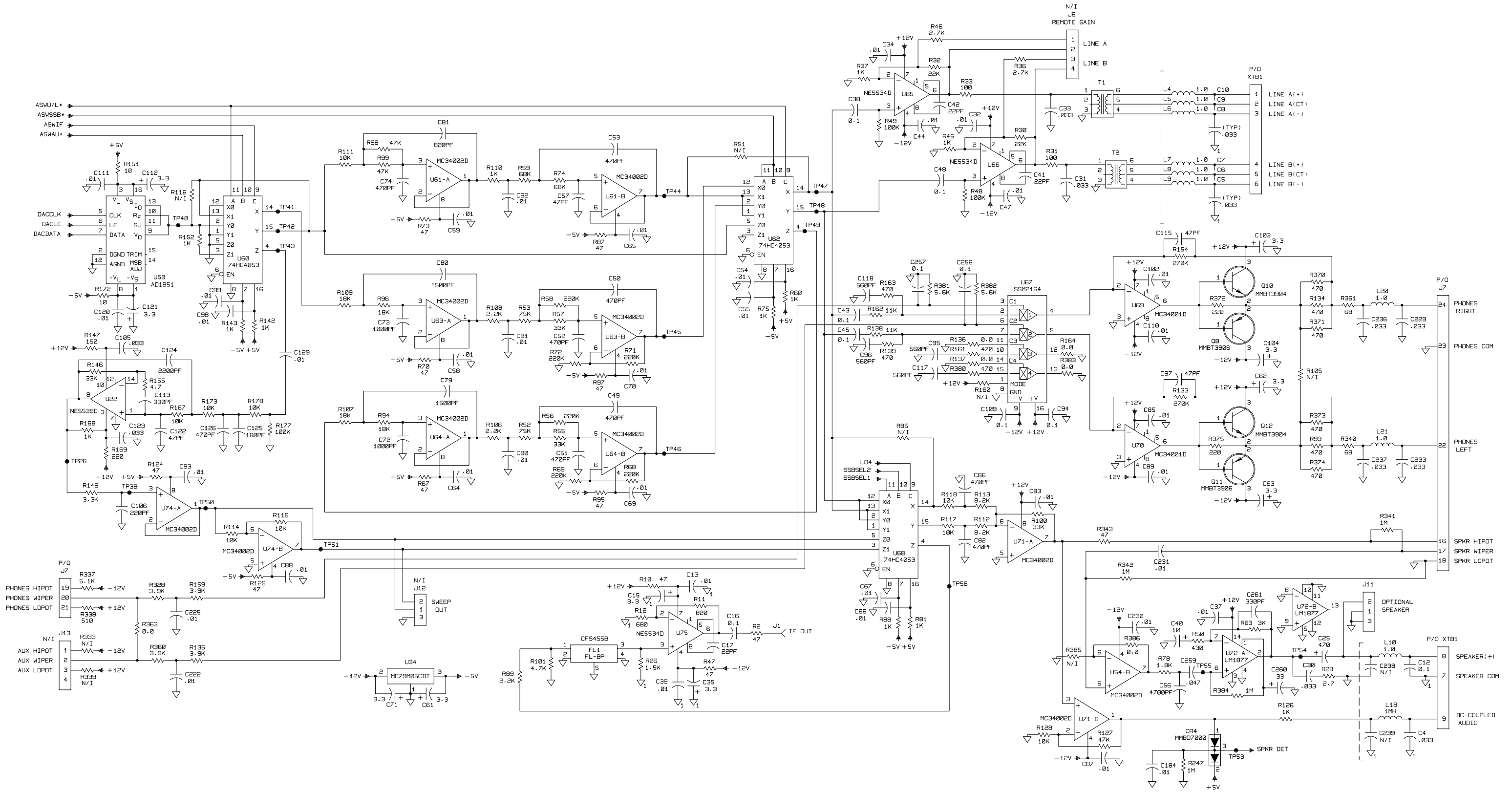

FO-6A. Type 904978-1 Digital Control Assembly (A2),
Schematic Diagram 904981 (Sheet 4 of 4) (D)
FP-35/(FP-36 blank)

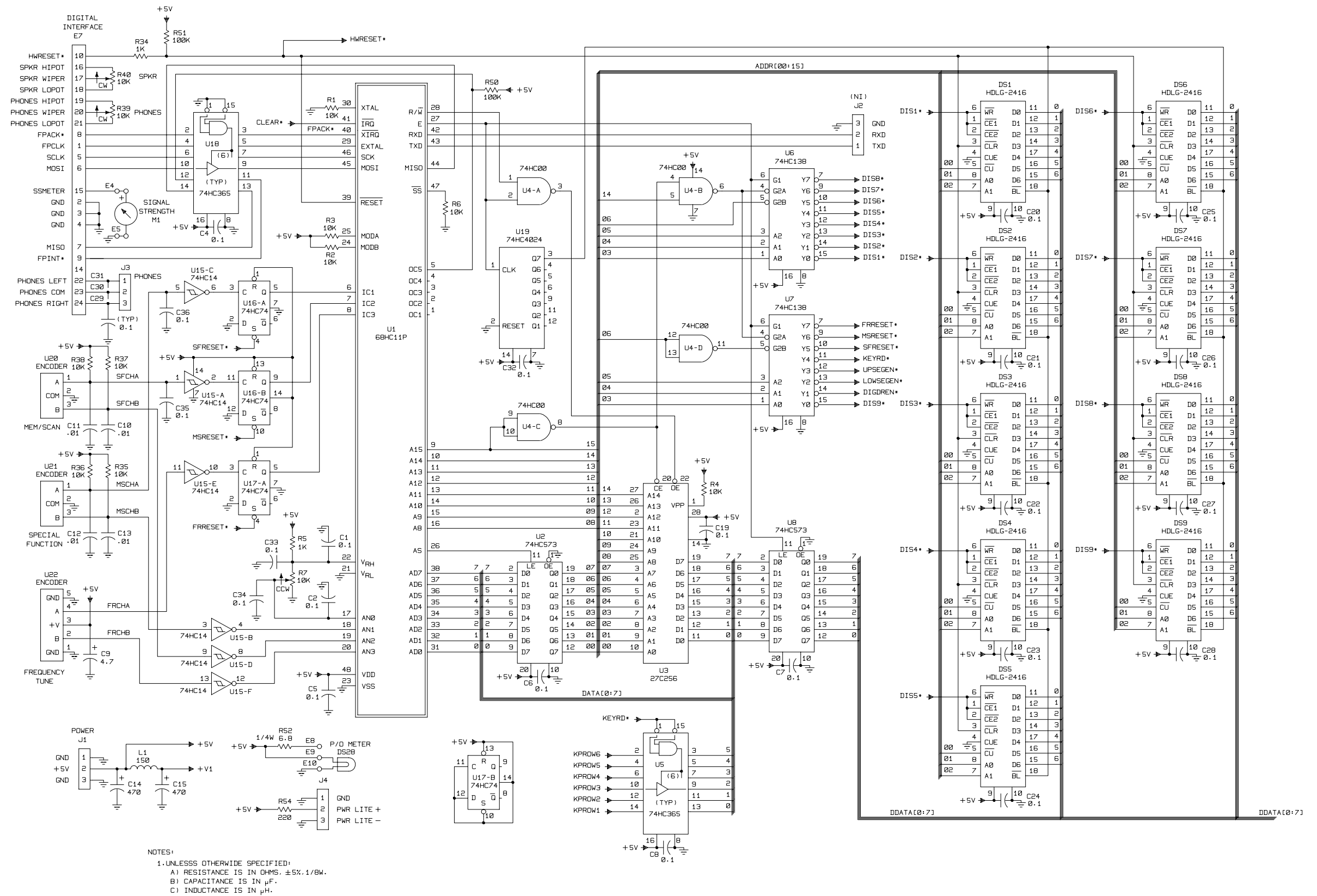

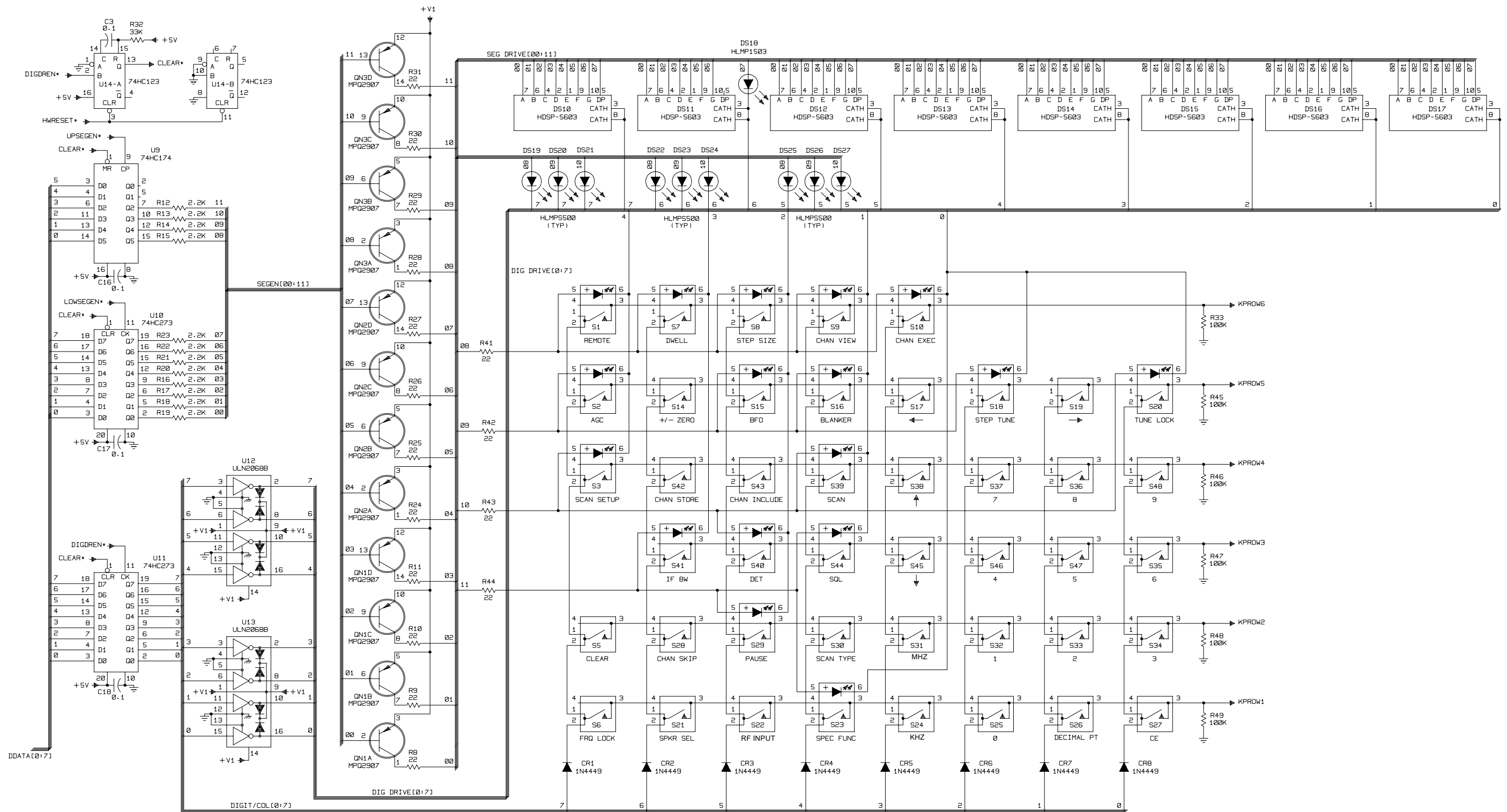

FO-7. Type 482108-1 Front Panel Circuit Card Assembly(A2A1),
Schematic Diagram 581267 (Sheet 2 of 2) (F)
FP-31/(FP-32 blank)

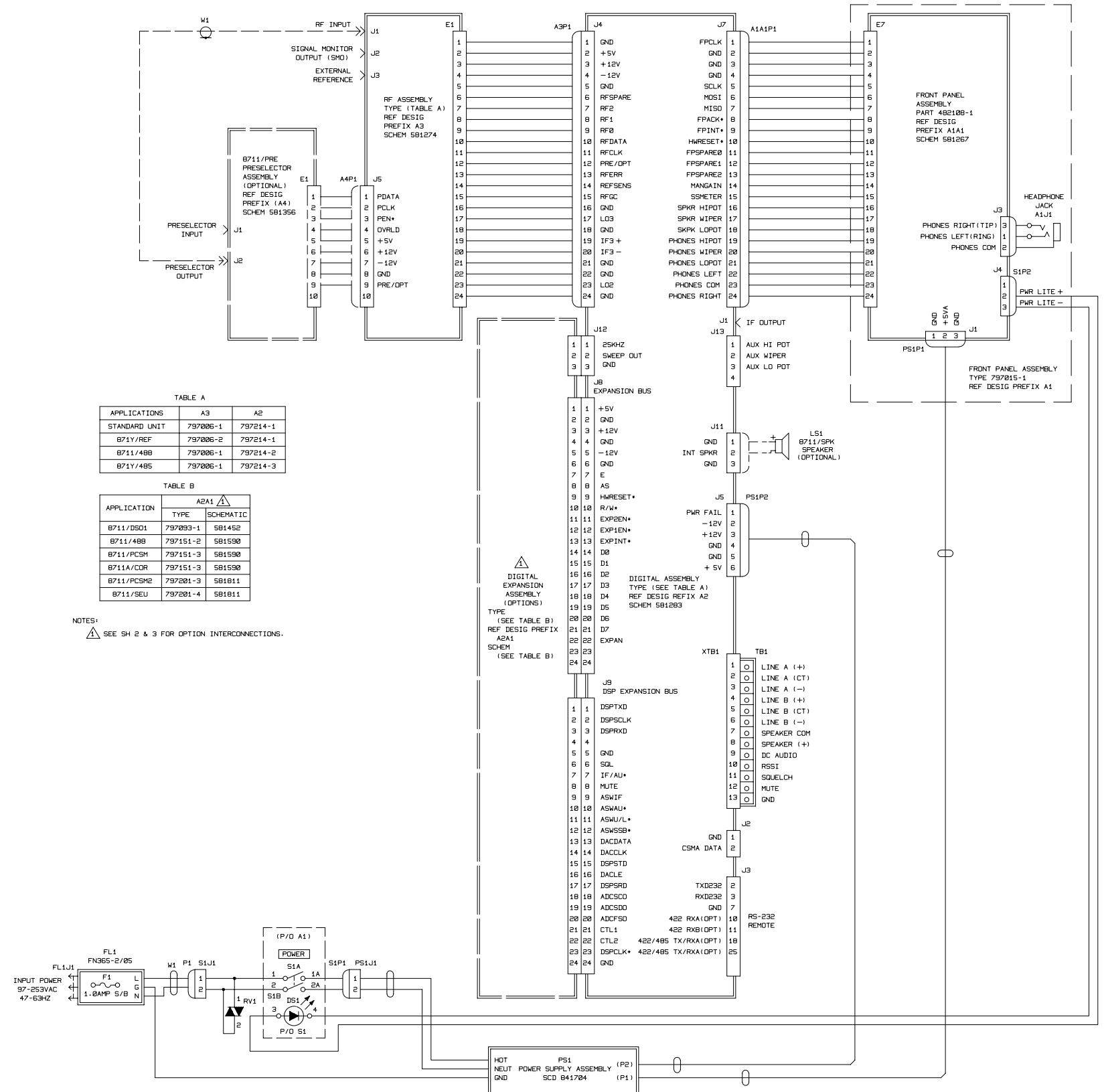

TABLE A

APPLICATIONS	A3	A2
STANDARD UNIT	797006-1	797214-1
871Y/REF	797006-2	797214-1
8711/488	797006-1	797214-2
871Y/485	797006-1	797214-3

TABLE B

APPLICATION	A2A1	
	TYPE	SCHEMATIC
8711/DS01	797093-1	581452
8711/488	797151-2	581590
8711/PCSM	797151-3	581590
8711A/CDR	797151-3	581590
8711/PCSM2	797201-3	581811
8711/SEU	797201-4	581811

NOTES:
 △ SEE SH 2 & 3 FOR OPTION INTERCONNECTIONS.

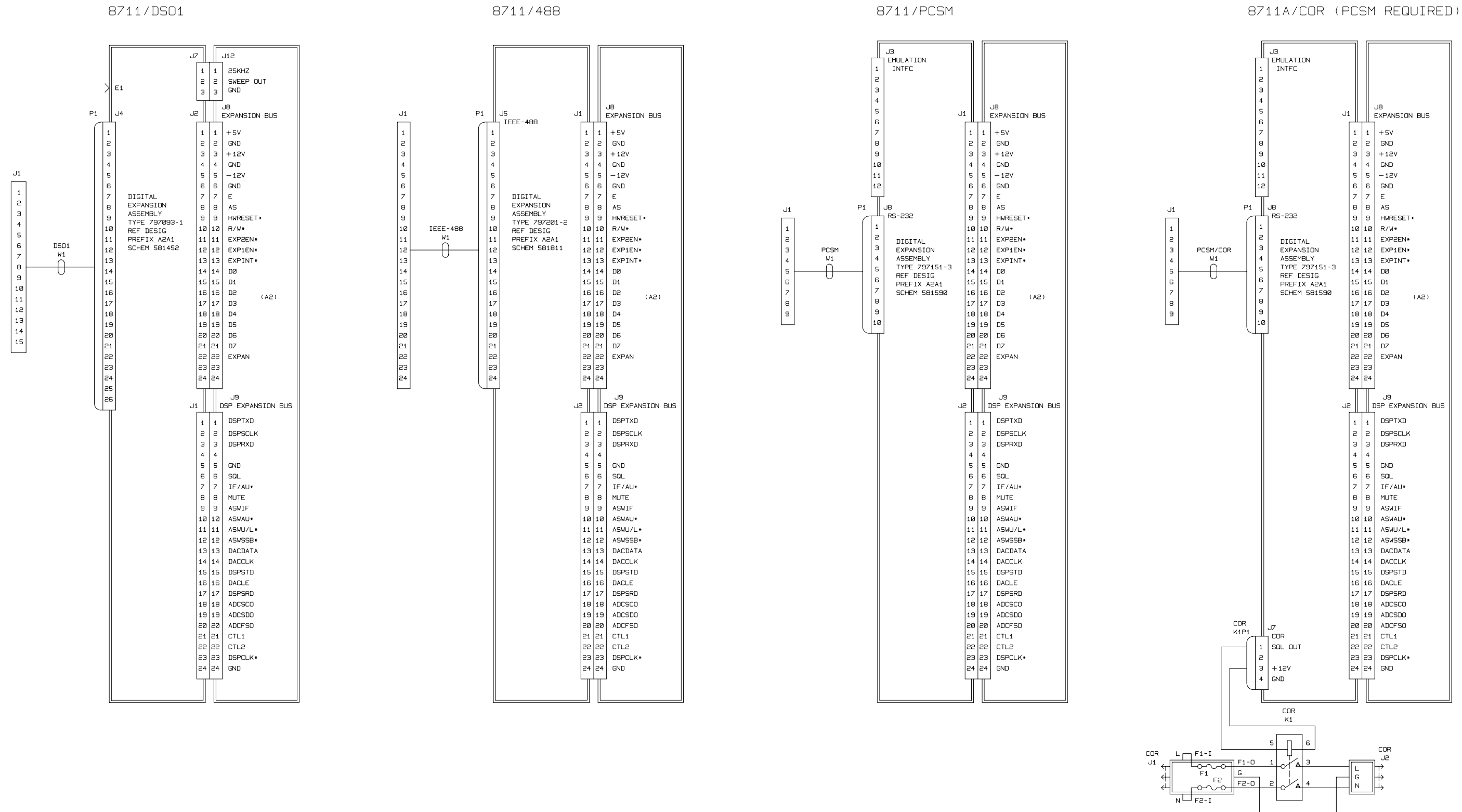

FO-8. Type WJ-8711A Digital HF Receiver, Main Chassis Schematic Diagram 581650 (Sheet 2 of 3) (G) FP-35/(FP-36 blank)

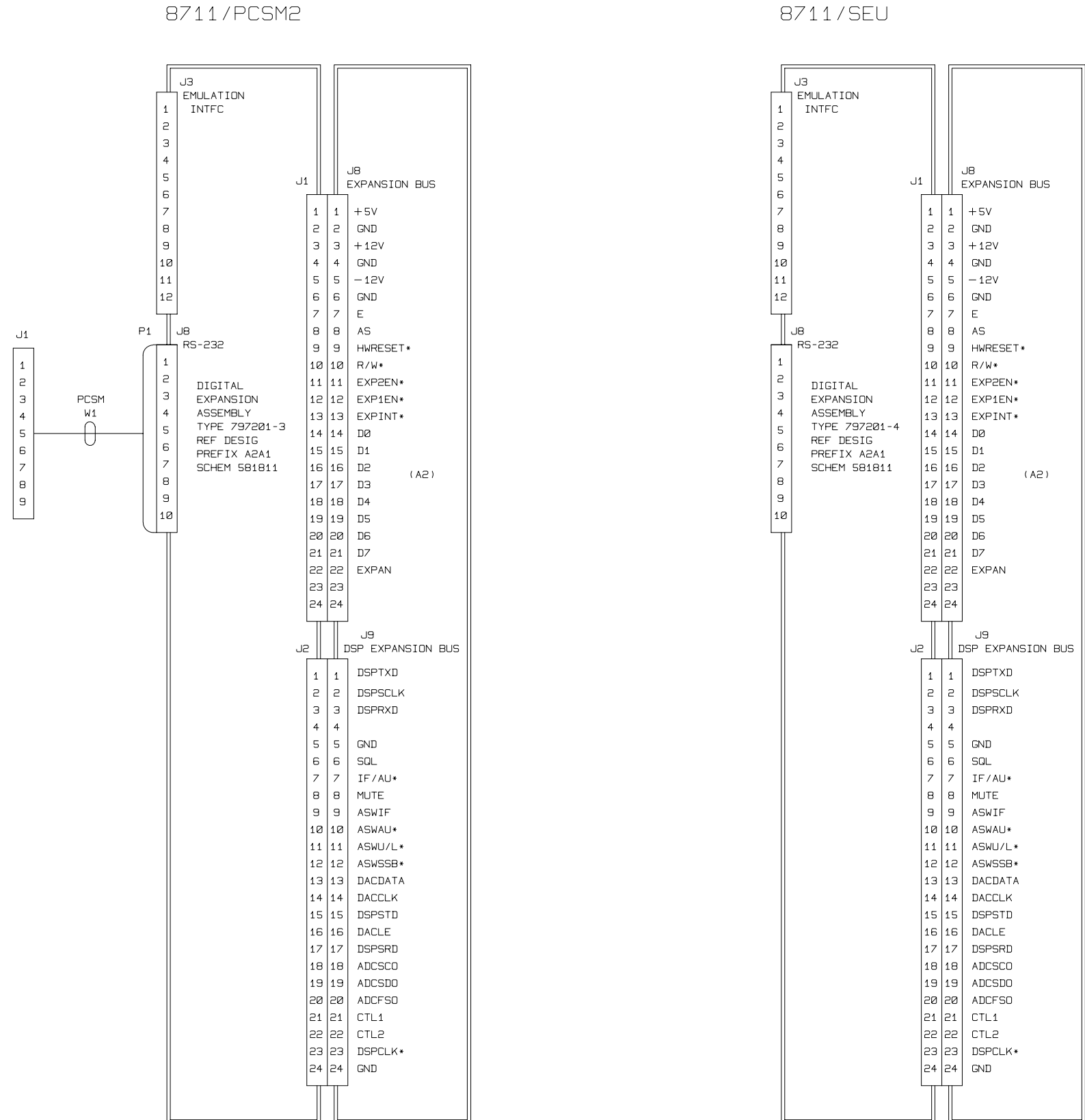

FO-8. Type WJ-8711A Digital HF Receiver, Main Chassis Schematic Diagram 581650 (Sheet 3 of 3) (G) FP-37/FP-38 blank)