

TM 11-885

WAR DEPARTMENT TECHNICAL MANUAL

RADIO RECEIVER R-140/FSM-1

NATIONAL HRO
SERIES OF RECEIVERS

WAR DEPARTMENT TECHNICAL MANUAL
TM 11-885

This manual supersedes TM 11-885, Radio Receiver R-140/FSM-1 (National HRO Series of Radio Receivers, and Associated Power Supplies), 30 June 1945

RADIO RECEIVER
R-140/FSM-1

NATIONAL HRO
SERIES OF RECEIVERS



WAR DEPARTMENT

AUGUST 1946

CONTENTS

	<i>Paragraph</i>	<i>Page</i>
PART ONE. INTRODUCTION.		
<i>Section I.</i> Description.		
General	1	1
Technical characteristics	2	1
Frequency spectrum chart	3	2
Table of components	4	3
Packaging data	5	3
Description of major components	6	8
Differences in models, Radio Receiver R-140/FSM-1	7	12
Differences in models, National HRO series of receivers ..	8	14
<i>II.</i> Installation.		
Siting	9	17
Unpacking, uncrating, and checking	10	17
Assembly for operation	11	17
PART TWO. OPERATING INSTRUCTIONS.		
<i>Section III.</i> Controls and their use.		
Front panel controls	12	19
<i>IV.</i> Operation.		
Starting procedure	13	20
Voice reception	14	20
C-W or tone operation	15	24
Reception with crystal filter	16	24
Stopping procedure	17	25
<i>V.</i> Equipment performance check list.		
Purpose and use of check list	18	25
Equipment performance check list	19	26
PART THREE. MAINTENANCE INSTRUCTIONS.		
<i>Section VI.</i> Preventive maintenance techniques.		
Meaning of preventive maintenance	20	29
Description of preventive maintenance techniques	21	29
Vacuum tubes	22	30
Capacitors	23	31
Resistors	24	31
Bushings and insulators	25	31
Switches	26	32
Coils	27	32
Rheostats and potentiometers	28	32
Terminal blocks	29	33
Multiple connectors	30	33
Cords and cables	31	33
S-meter	32	33
Pilot lamp	33	33
Jack and plugs	34	34
Cabinets, chassis, and mountings	35	34
Headset and loudspeaker	36	34
Coupling shafts and control knobs	37	34
Gears	38	34
<i>VII.</i> Itemized preventive maintenance.		
Introduction	39	34
Preventive maintenance tools and materials	40	35
Item 1, front of operating panel	41	35
Item 2, top of chassis	42	35
Item 3, bottom of chassis	43	35
Item 4, power supplies	44	35
Preventive maintenance check list	45	35

	<i>Paragraph</i>	<i>Page</i>
VIII. Lubrication.		
IX. Moistureproofing and fungiproofing.		
General	46	36
Treatment	47	36
Moistureproofing and fungiproofing i-f transformers of receiver	48	36
Moistureproofing and fungiproofing plug-in coils of receiver	49	38
Moistureproofing and fungiproofing chassis of receiver	50	38
Moistureproofing and fungiproofing rectifier power unit, Navy type No. 20090	51	39
Moistureproofing and fungiproofing Power Supply SPU-686-S	52	39
Moistureproofing and fungiproofing Power Supply 686		40
Moistureproofing and fungiproofing Power Supply 697	54	40
 PART FOUR. AUXILIARY EQUIPMENT. (Not used)		
 PART FIVE. REPAIR INSTRUCTIONS.		
Section X. Theory of equipment.		
Simplified block diagram	55	42
Condensed theory of receiver operation	56	42
XI. Trouble shooting.		
General trouble-shooting information	57	45
Trouble location chart	58	48
Sectionalizing trouble in Radio Receiver R-140/FSM-1 (National HRO Series of Receivers) and power supplies	59	49
Tube socket voltage measurements	60	51
Point-to-chassis resistance measurements	61	51
Voltage gain per stage	62	52
Test equipment	63	53
Illustrations and schematic diagrams	64	53
XII. Repairs.		
Rustproofing and repainting	65	69
Unsatisfactory equipment report	66	69
XIII. Alignment and adjustment.		
Correct methods of alignment and adjustment	67	69
Test instruments used for alignment and adjustment	68	71
Minimum test requirements	69	71
 APPENDIX I. REFERENCES.		
Army regulations	1	74
Supply publications	2	74
Technical manuals on auxiliary equipment and test equipment	3	74
Painting, preserving, and lubrication	4	74
Shipping instructions	5	74
Decontamination	6	74
Demolition	7	74
Camouflage	8	74
Other publications	9	74
Forms	10	75
Abbreviations	11	75
 II. MAINTENANCE PARTS.		
Maintenance parts for Radio Receiver R-140/FSM-1	1	76
Maintenance parts for Radio Receiver (National model HRO-MX), power supply (National type SPU 686-S), and power supply (National type SPU 697)	2	79
List of manufacturers	3	82

PART ONE

INTRODUCTION

Section I. DESCRIPTION

I. General

a. Radio Receiver R-140/FSM-1 (National HRO series of receivers) is a nine-tube superheterodyne receiver. (See fig. 1.) Though portable, it is intended for fixed station use. The equipment is designed for reception of voice or tone amplitude modulated (a-m) signals, and continuous wave (c-w) signals. Either manual or automatic volume control (avc) may be used.

b. The receiver is supplied as a rack mounting model, equipped with a sheet metal cabinet which completely incloses the chassis and provides protection against dust and damage. Complete with nine coil sets, but without power supply, it weighs 53 pounds.

c. While this manual mentions in particular Radio Receiver R-140/FSM-1, the text applies generally to all National receivers known as the HRO-senior series. They are all basically alike in operation and design whether they be rack mounting or table models. Radio Receiver R-140/FSM-1 refers to any National HRO-senior model receiver with several minor circuit modifications to make it adaptable for use with Frequency Measuring Assembly CY-93/FAM-1, in addition to being used as a regular receiver. Differences between the various models of HRO receivers, and the modifications in Radio Receiver R-140/FSM-1, are described in paragraphs 7 and 8.

d. Radio Receiver R-140/FSM-1 and all models of the National HRO series of receivers are operated from external power supplies. Power supply (National type SPU-686-S) is for use with a 6-volt, d-c power source. Power supply (National type SPU-697) (rectifier power unit, Navy type No. 20090) is for a 115-volt, 50- to 60-cycle a-c power source.

Both are rack mounting units. Rectifier power unit, Navy type No. 20090, is supplied with Radio Receiver R-140/FSM-1.

e. Power supply (National type 686-S) and power supply (National type 697) are electrically interchangeable with the power unit in *d* above; but they are designed for table use with the receivers and differ in appearance and dimensions.

2. Technical Characteristics

The table below lists the technical data and general characteristics of Radio Receiver R-140/FSM-1, and the National HRO series of radio receivers.

Frequency range:

Nine coil sets are available for the following frequencies:

Type J	50 to 100 kc
Type H	100 to 200 kc
Type G	180 to 430 kc
Type F	480 to 960 kc
Type E	900 to 2050 kc
Type D ¹	1.7 to 4.0 mc
Type C ¹	3.5 to 7.3 mc
Type B ¹	7.0 to 14.4 mc
Type A ¹	14.0 to 30.0 mc

Receiver type Superheterodyne
Types of signals which can be received a-m, c-w, and voice

Number of tubes 9

¹ Coil sets JA, JB, JC, or JD may be supplied instead of sets A, B, C, and D respectively. Sets A, B, C, and D have a band spread feature which the others lack.

Intermediate frequency 456 kc

Power input:

240-volt d-c input 70 ma

6.2-volt a-c input 3.4 amp

Power supply External

Antenna Doublet or single wire

Antenna input impedance Approximately 500 ohms above 1,700 kc

Weight with coil sets, less power unit:

Radio Receiver R-140/FSM-1 and rack mounting

HRO Receivers 53 lb.

Table model HRO receivers 51 lb.

FREQUENCY SPECTRUM: *Megacycles*

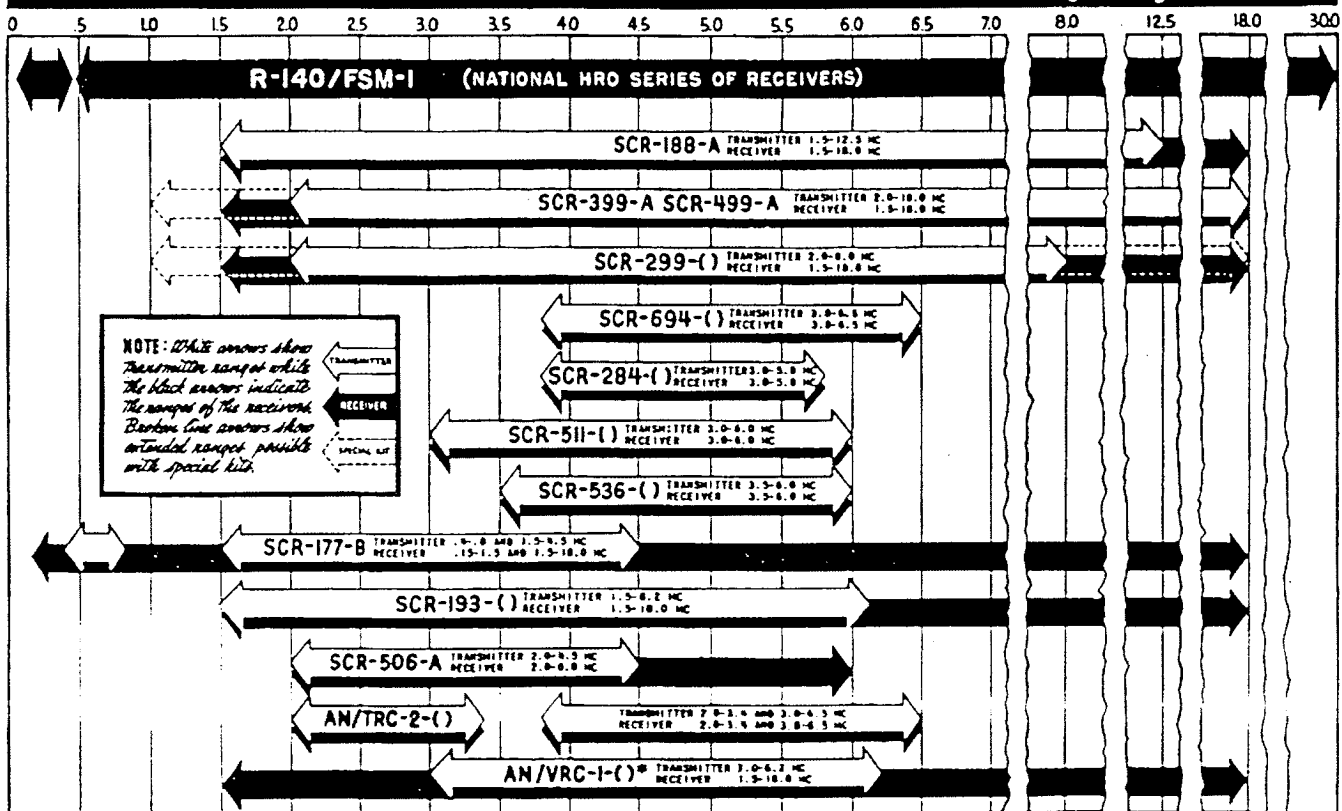

*Additional frequencies of the AN/VRC-1 are: transmitter 100-155 MC and receiver 100-155 MC

TL123525

Figure 2. Radio Receiver R-140/FSM-1 (National HRO series of receivers)—frequency spectrum chart.

3. Frequency Spectrum Chart (fig. 2)

a. RECEIVERS. The receivers have a frequency range of from 50 to 430 kilocycles (kc)

and from 480 kc to 30 megacycles (mc). (See fig. 2.)

b. PLUG-IN COIL SETS. Individual coil set coverage is shown in figure 3.

KILOCYCLES

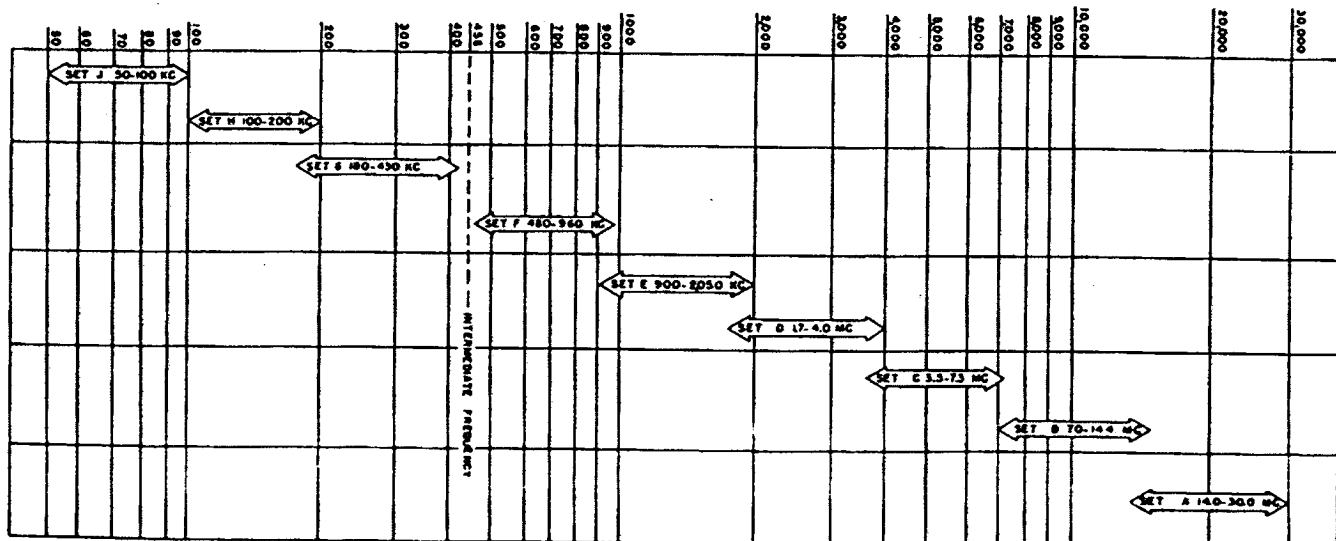

Figure 3. Coil set—frequency spectrum chart.

TL123535

4. Table of Components

a. The equipment listed in the following table is supplied for operation of Radio Receiver R-140/FSM-1.

Component (unpacked)	Required No.	Height (in.)	Depth (in.)	Length (in.)	Volume (cu. ft.)	Weight (lb.)
Radio Receiver R-140/FSM-1 complete with tubes, pilot lamp, and 1 coil set.	1	8 $\frac{3}{4}$	12	19	1.0	37
Power supply SPU-697 (Rectifier power unit, Navy type No. 20090).	1	5 $\frac{3}{4}$	9 $\frac{3}{4}$	19	0.6	22
Coil box with 8 coil sets.	1	4 $\frac{3}{4}$	11 $\frac{1}{2}$	20 $\frac{1}{16}$	0.8	22

Note. This list is for general information only. (See appropriate publications for information pertaining to requisition of spare parts.)

b. The equipment listed below is supplied for operation of table models of the National HRO series of receivers.

Component (unpacked)	Required No.	Height (in.)	Depth (in.)	Length (in.)	Volume (cu. ft.)	Weight (lb.)
National HRO receiver, table model, complete with tubes, pilot lamp, and 1 coil set.	1	9	10 $\frac{1}{2}$	17 $\frac{1}{4}$	0.9	35
Power Supply 686-S complete with fuse and rectifier tube JAN-6X5, or JAN-OZ4.	1	6	7 $\frac{1}{4}$	7 $\frac{1}{2}$	0.2	10
Power Supply 697 complete with rectifier tube JAN-80.	1	6	7 $\frac{1}{4}$	7 $\frac{1}{2}$	0.2	12
Coil Box with 3 coil sets.	1	8 $\frac{3}{4}$	5 $\frac{3}{4}$	11 $\frac{1}{2}$	0.3	8 $\frac{1}{2}$
Coil Box with 5 coil sets.	1	13 $\frac{1}{2}$	5 $\frac{3}{4}$	11 $\frac{1}{2}$	0.5	14

Note. This list is for general information only. (See appropriate publications for information pertaining to requisition of spare parts.)

5. Packaging Data (figs. 4, 5, and 6)

a. Radio Receiver R-140/FSM-1 and its components are each packed in two nested cartons and protected by a weatherproof bag. Each component is then packed in an individual wooden box, the size, weight, and volumes of which is shown below.

Component (in box)	Height (in.)	Width (in.)	Length (in.)	Volume (cu. ft.)	Approximate weight (lb.)
Radio Receiver R-140/FSM-1, with tubes, pilot lamp, and 1 coil set.	13	18	24	3.2	75
Power Supply SPU-697 (rectifier power unit, Navy type No. 20090).	9	14	24	1.1	47
Coil box with eight coil sets.	14	20	30	4.8	89

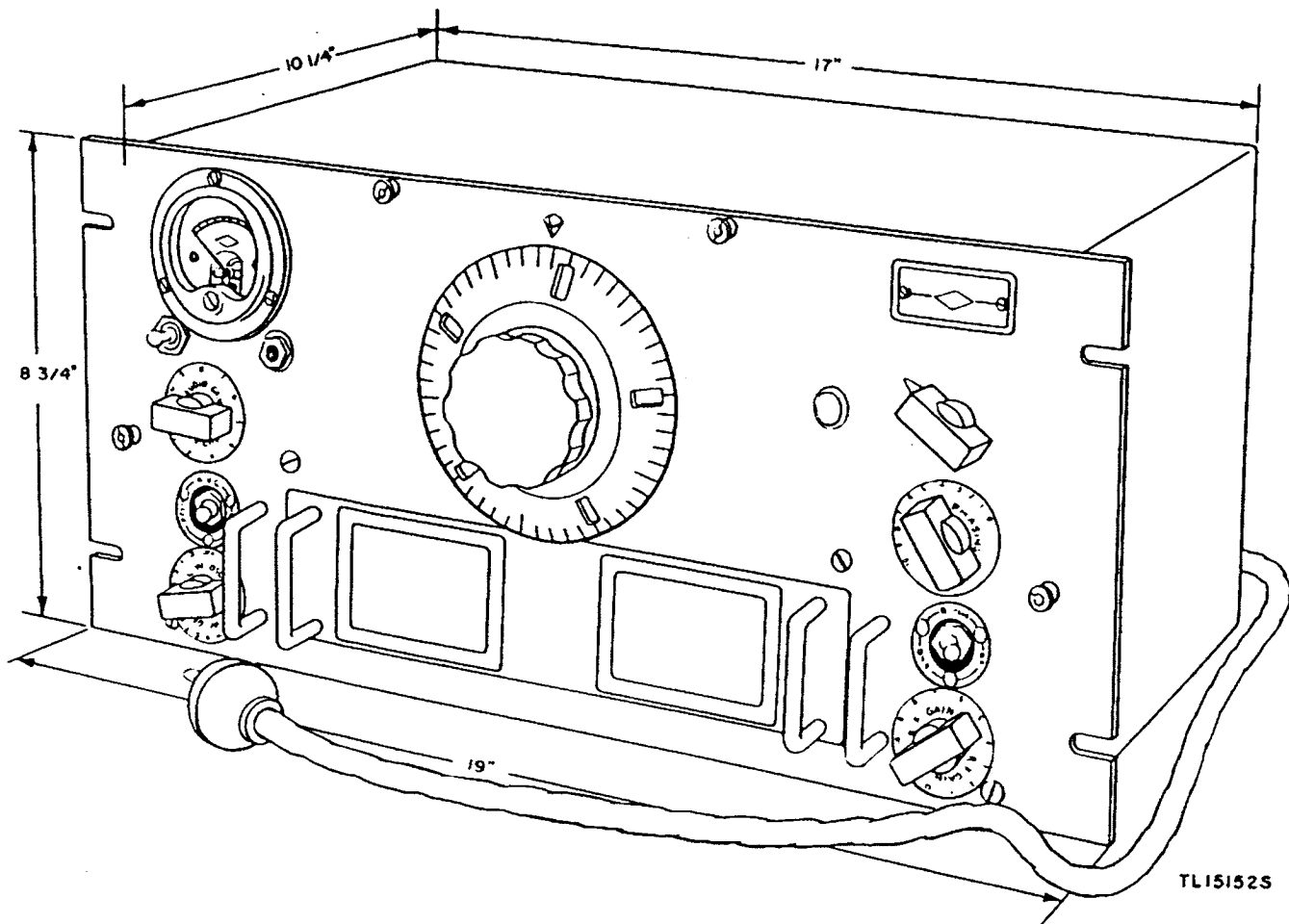

Figure 4. Radio Receiver R-140/FSM-1—outline dimensional drawing.

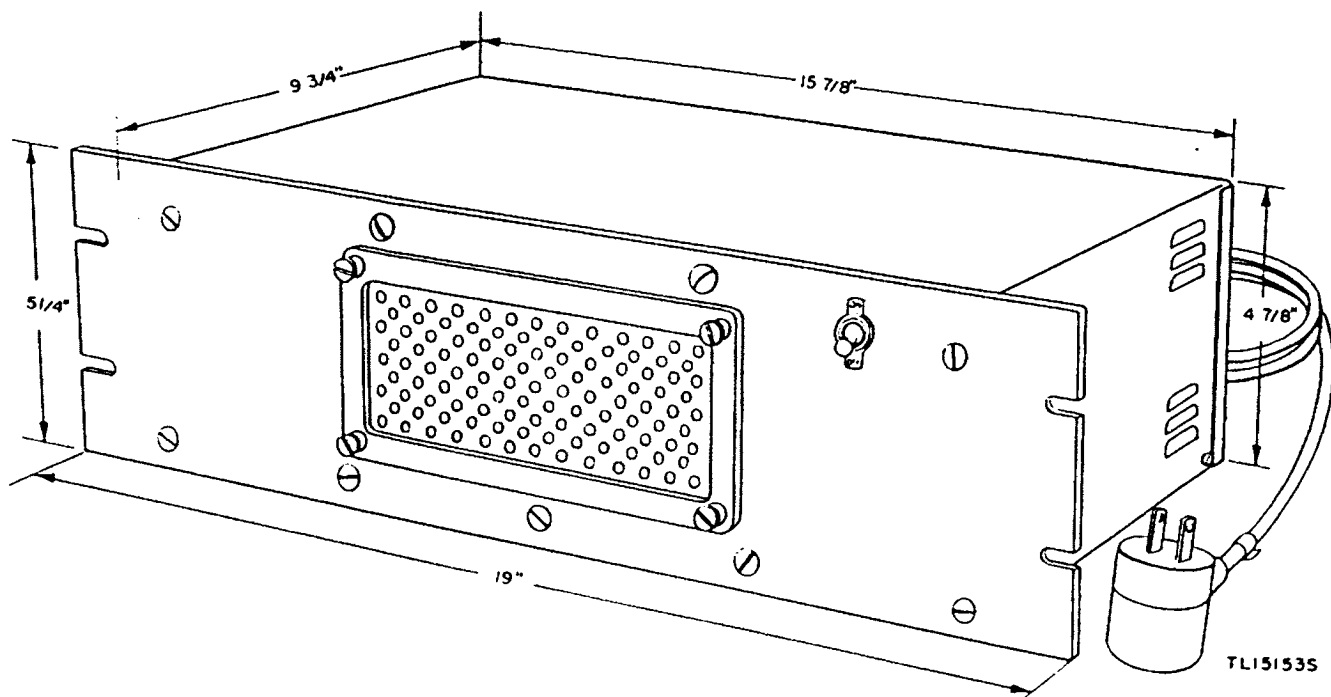
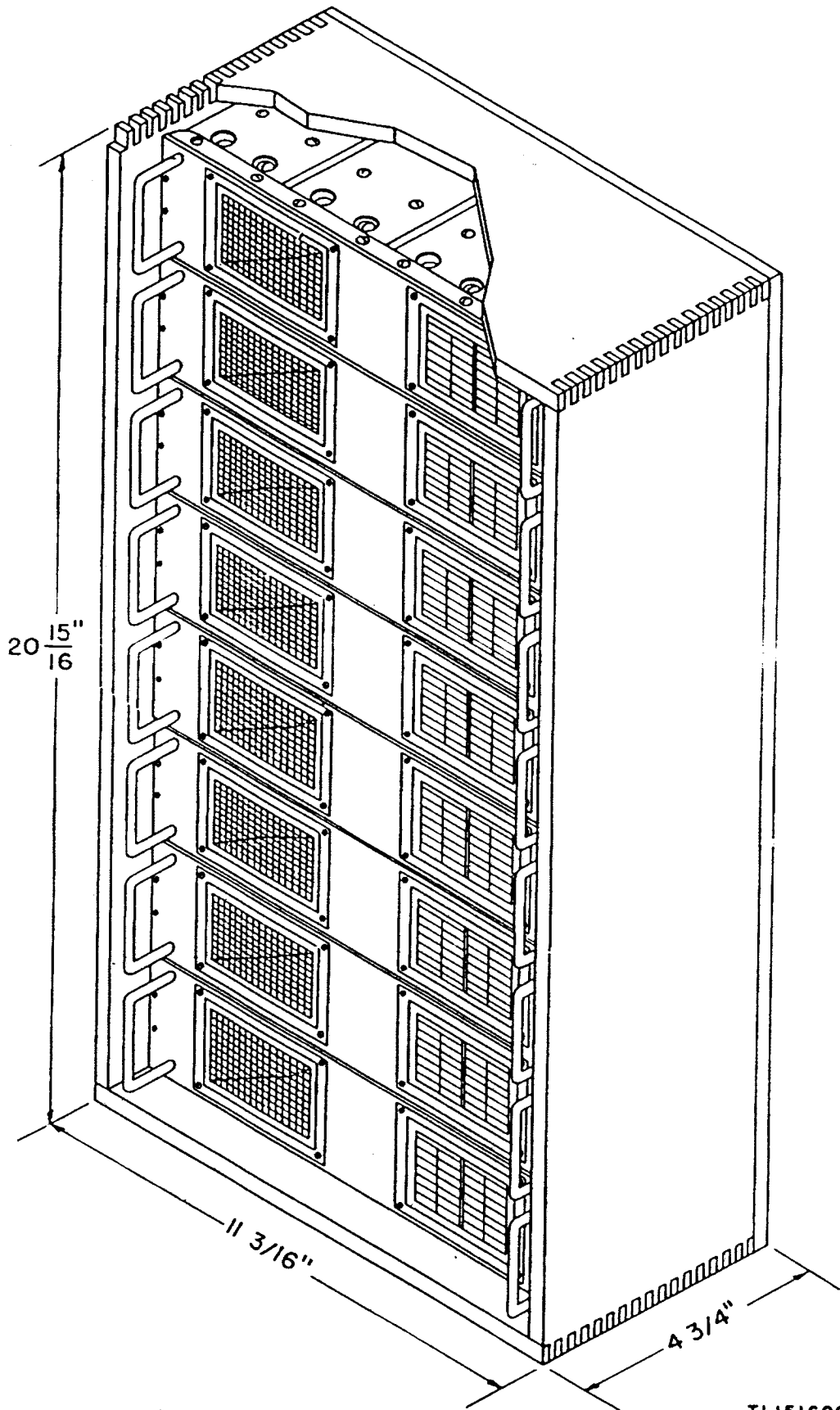

Figure 5. Power Supply SPU-697 (rectifier power unit, Navy type No. 20090)—outline dimensional drawing.



TL15160S

Figure 6. Box with eight coil sets—outline dimensional drawing.

b. Table models of the National HRO series of receivers and components are packed in a

wooden crate, the size, weight, and volume of which are shown below. (See fig. 7.)

Component	Height (in.)	Width (in.)	Length (in.)	Volume (cu. ft.)	Weight (lb.)
Wooden crate, containing 1 National HRO receiver, 2 power supplies, coil box with 3 coil sets, coil box with 5 coil sets.	14¾	23½	37	7.3	160 (approx.)

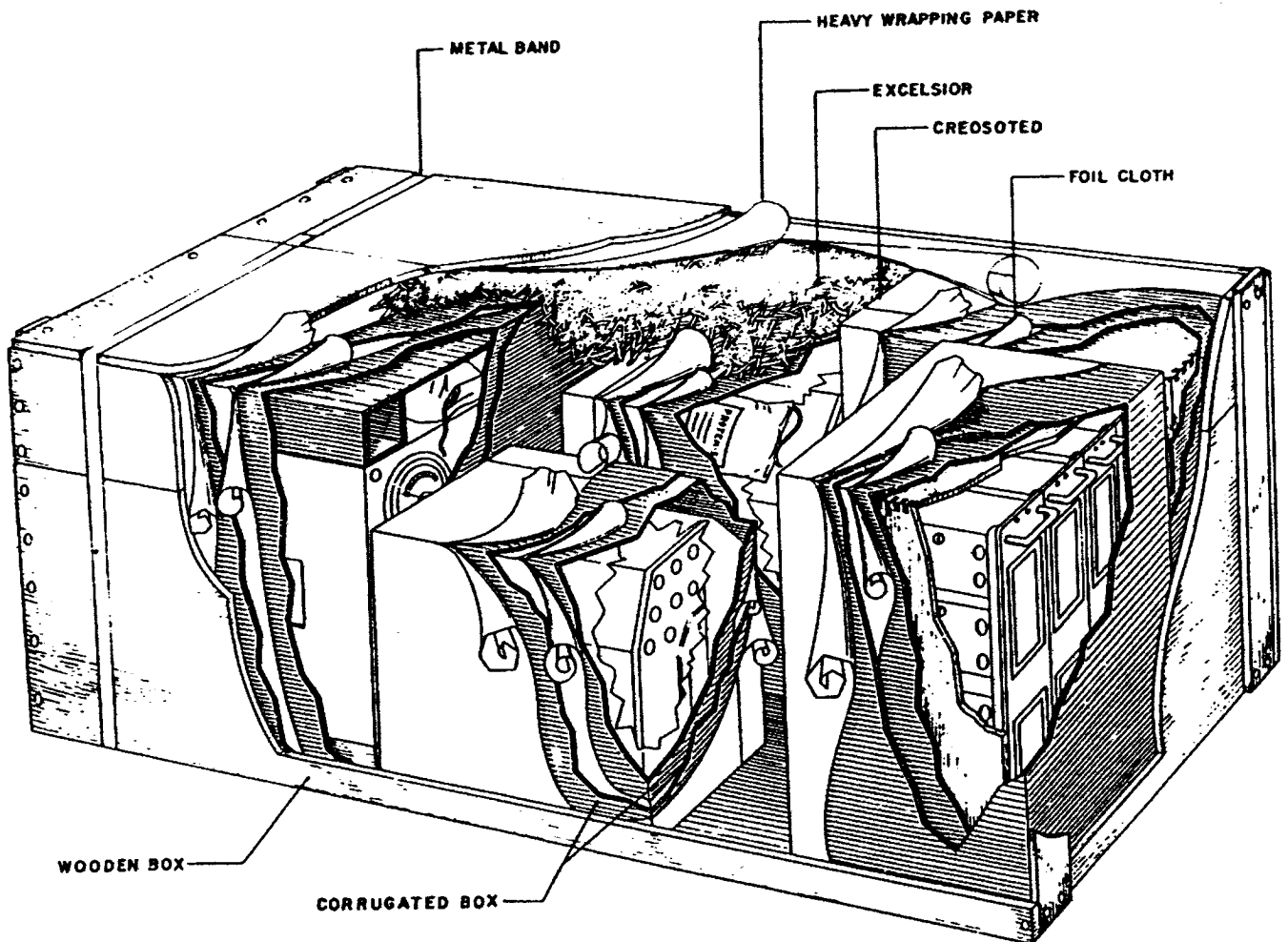

TL123545

Figure 7. National HRO series of receivers and power supplies and coils as crated.

c. Dimensions, volume and weight of packed components of table models (National HRO

series of receivers) are shown below. Figures 8, 9, 10, 11 and 12 show table models unpacked.

Component	Height (in.)	Depth (in.)	Length (in.)	Volume (cu. ft.)	Weight (lb.)
National HRO receiver, complete with tubes, pilot lamp, and 1 coil set.	13	15½	21½		44
Power Supply 686-S complete with fuse and rectifier Tube JAN-OZ4, or JAN-6X5.	9	9½	10		14
Power Supply 697 complete with rectifier Tube JAN-80.	8½	9¼	9½		15
Coil box with three coil sets.	7½	10	13		13
Coil box with five coil sets.	8	13	14		19½

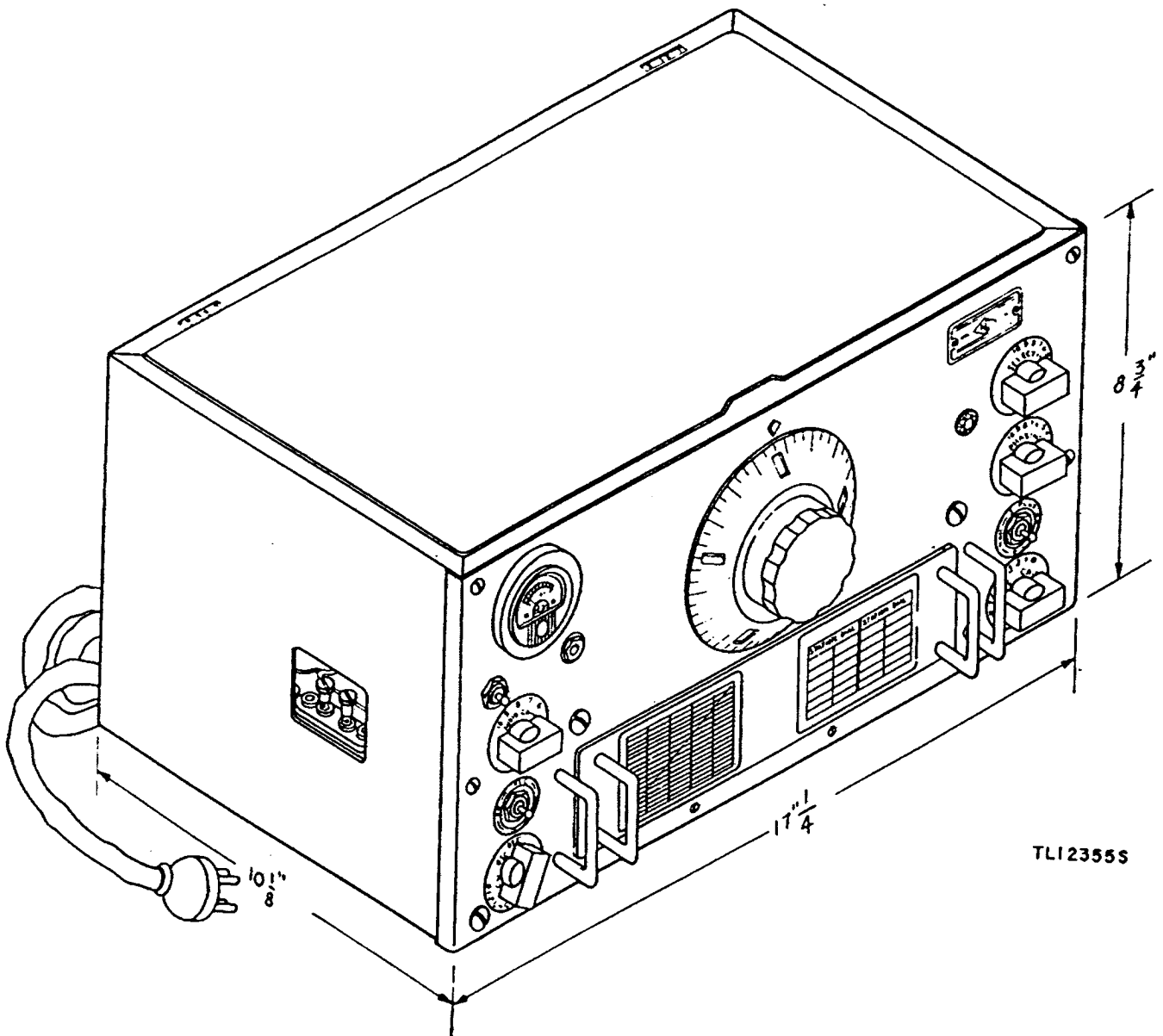

Figure 8. National HRO series of receivers (table models)—outline dimensional drawing.

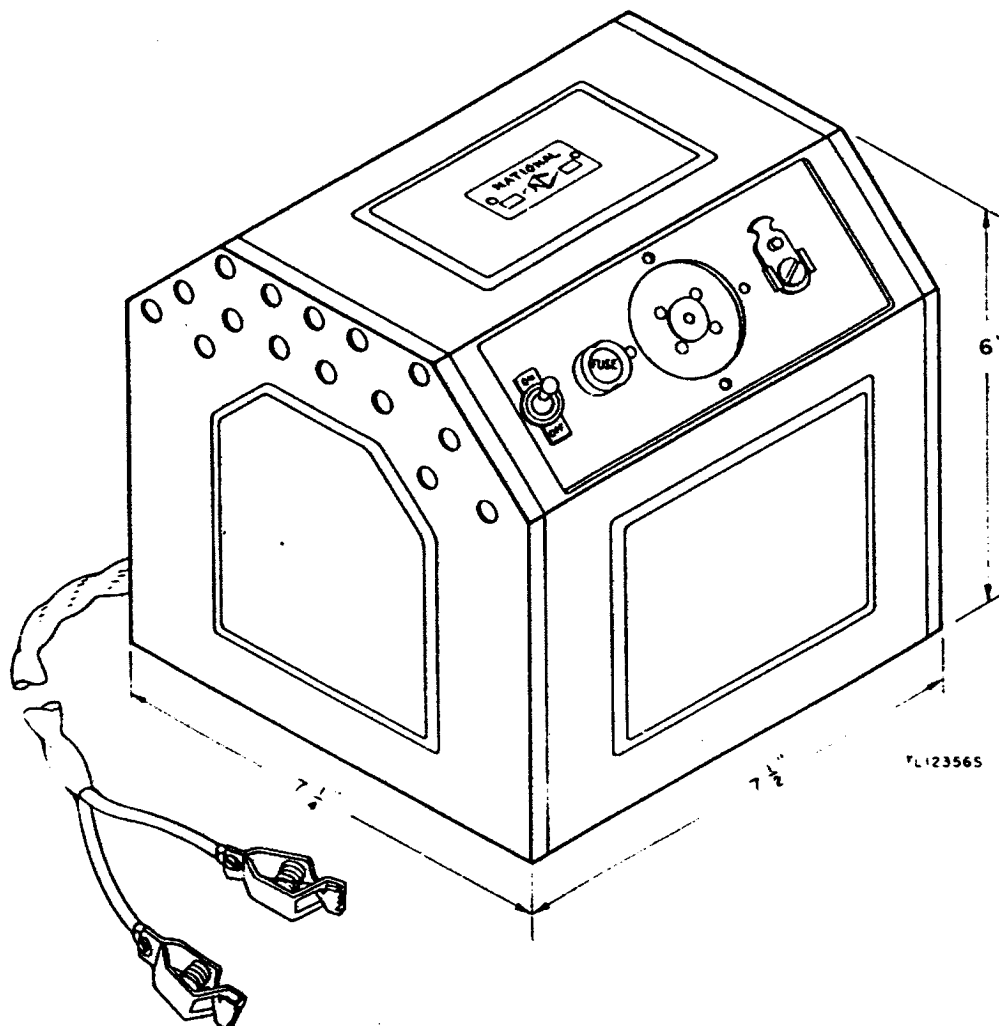

Figure 9. Power supply (National type 685-S)—outline dimensional drawing.

6. Description of Major Components

a. Radio Receiver R-140/FSM-1 consists of a chassis and sheet metal cabinet. (See fig. 13.) The phone jack, the pilot lamp, and all the controls are located on the front panel. The loudspeaker terminals and auxiliary relay connections are on terminal boards at the rear of the receiver. The cabinet is removed from the receiver whenever it is necessary to expose the tubes or the top of the chassis. To do this, remove the four knurled thumbscrews on the front panel, and three sheet metal screws at the lower rear of the cabinet. The bottom of the chassis is fitted with a gray enameled steel plate to provide protection against dirt and damage. Table models of National HRO receivers are equipped with a cabinet having a hinged top cover. (See fig. 14.)

b. Power Supply SPU-686-S is for use with a 6-volt, d-c power source. It is a rack mounting unit consisting of a vibrapack and a capacitor input single section filter. Battery clips are provided for convenient connection to a 6-volt storage battery or similar source of power. Output voltages for both filament and plate supply are taken off at a 4-prong socket (X-1) at the rear of the set by inserting a receiver power cable (W-1).

c. Power Supply SPU-697 (rectifier power unit, Navy type No. 20090) operates from 115-volt, 50- to 60-cycle alternating current. (See fig. 15.) It is a rack mounting unit similar in appearance to Power Supply SPU-686-S. The OFF-ON switch (S-2-a) is mounted on the front panel along with a removable grill behind which is rectifier Tube JAN-80. Output voltages for both filament and plate supply are taken off at the four-prong socket (X-3) in

rear of the unit by inserting the receiver power cable (W-1).

Note. Some models of power supply (National type SPU-697), similar in appearance to rectifier power unit, Navy type No. 20090, will operate from either a

115- or 230-volt, 50- to 60-cycle, a-c power source. Proper input voltage is selected by means of a primary selector switch (S-3-a) within the cabinet. Be sure this switch is in the proper position when using this unit.

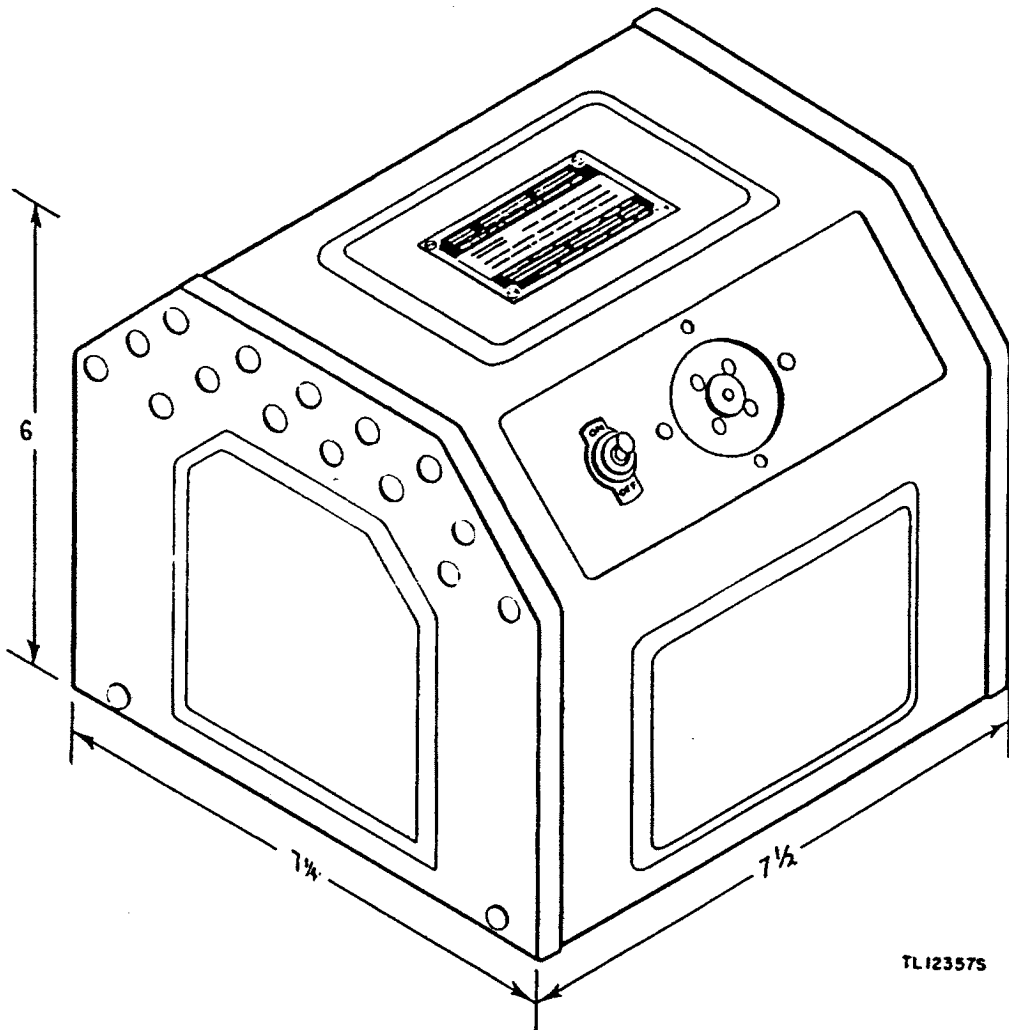

Figure 10. Power supply (National type 697)—outline dimensional drawing.

d. Power supply (National type 686-S) is for use with a 6-volt d-c power source. (See fig. 16.) It is housed in a sheet metal cabinet finished in crackle black enamel. The cabinet completely incloses the unit and contains no openings other than the air vents located at the sides. The front panel mounts the OFF-ON switch (S-1-a), the fuse holder, and the receptacle (X-1-a) for receiver cable W-1. Rectifier Tube JAN-0Z4, or Tube JAN-6X5, is mounted inside the cabinet.

e. Power supply (National type 697) operates from a 115- or 230-volt, 50- to 60-cycle alternating current. It differs only slightly in

appearance from Power Supply 686-S. The front panel carries the OFF-ON switch (S-2-a) and the receptacle (X-3-a) for receiver cable W-1. The bottom plate has an opening to provide access to rectifier Tube JAN-80 (V-1) and the primary tap selector switch (S-3-a). (See figs. 17 and 18.)

f. The two coil boxes (figs. 19 and 20) are made of wood, and are provided with inside cleats to form separate racks for the individual coil sets. The smaller box has space for three coil sets, the larger one accommodates five.²

² Radio Receiver R-140/FSM-1 is supplied with all eight coils in one box. (See fig. 1.)

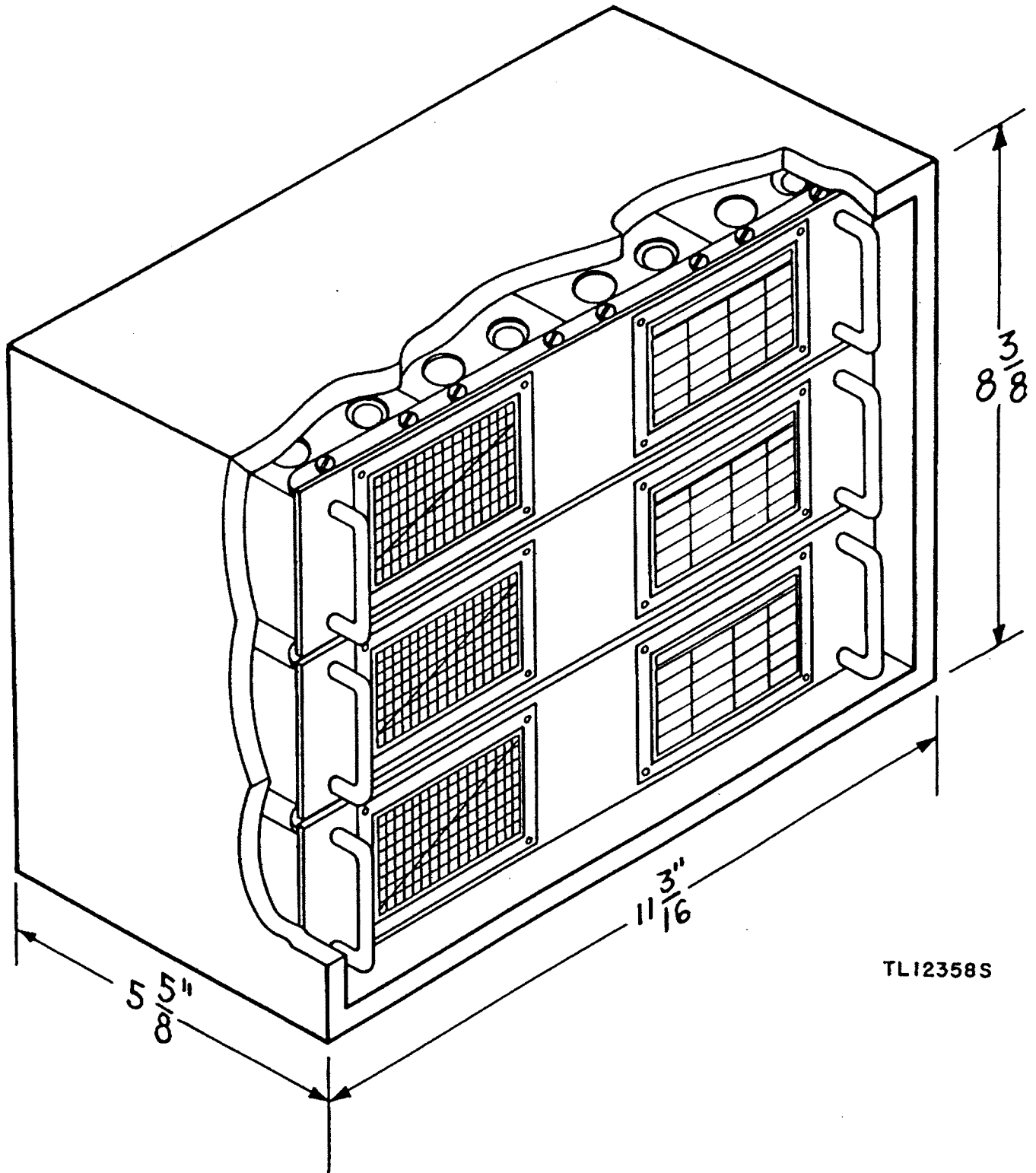

TL12358S

Figure 11. Box with three coil sets—outline dimensional drawing.

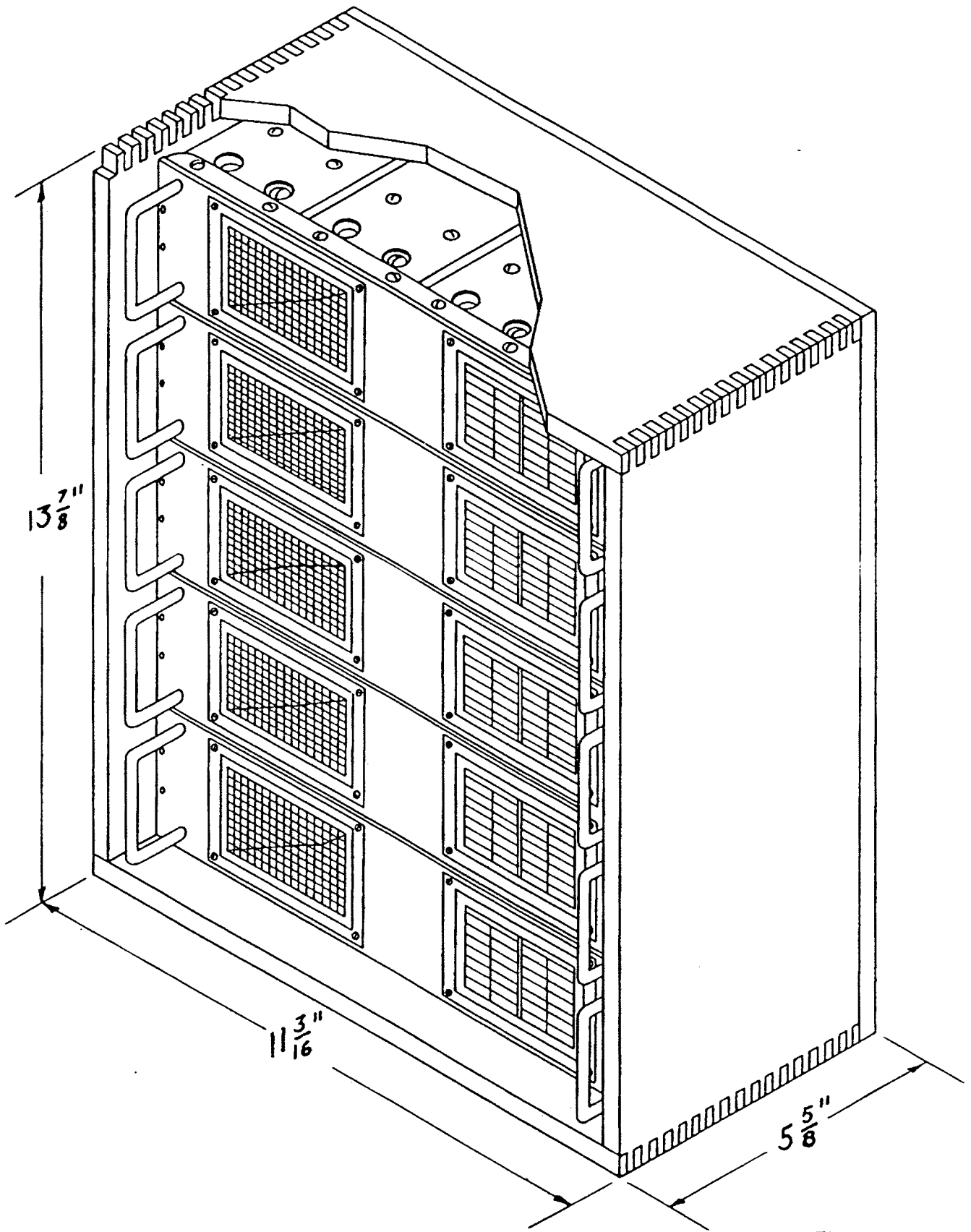

TL12359S

Figure 12. Box with five coil sets—outline dimensional drawing.

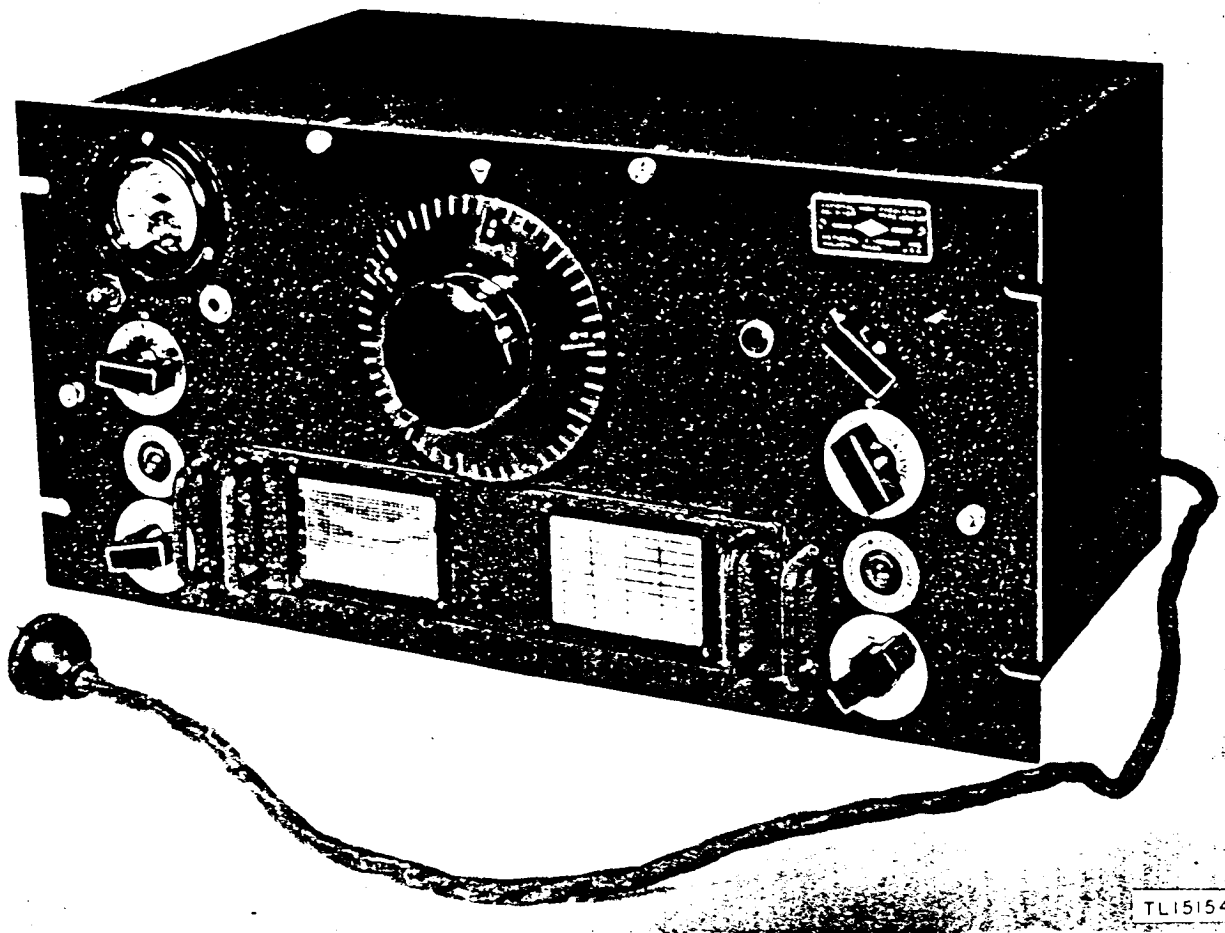

Figure 13. Radio Receiver R-140/FSM-1 in cabinet.

7. Differences in Models, Radio Receiver R-140/FSM-1

a. Radio Receiver R-140/FSM-1 is a receiver of the National HRO-senior series to which the following changes in wiring have been made:

(1) The break-in switch has been rewired so that it may be used to inject an audio signal into the detector tube. To accomplish this, the wires formerly connected to the break-in switch have been removed and connected together. Then one of the terminals of the break-in switch has been wired to ground, and the other has been connected to the cathode of the detector. When used in Test Set AN/FSM-3 (TM 11-2606) as part of Frequency Measuring Assembly CY-93/FSM-1, Audio Oscillator

TS-312/FSM-1 is connected to these terminals through a switching panel.

(2) The speaker jacks have been rewired to remove high voltage from them. This has been accomplished by removing both wires from the pin jacks and connecting them together through a 10,000-ohm, 10-watt resistor. One of the pin jacks is then connected to the plate of the audio output tube through a 0.1-microfarad, 600-volt capacitor. The other pin jack is grounded.

b. Most Radio Receivers R-140/FSM-1 are modifications of the National model HRO-MX receiver. These have glass tubes. Some receivers may be encountered which have metal tubes. These are National model HRO-5R, modified as in paragraph *a* above.

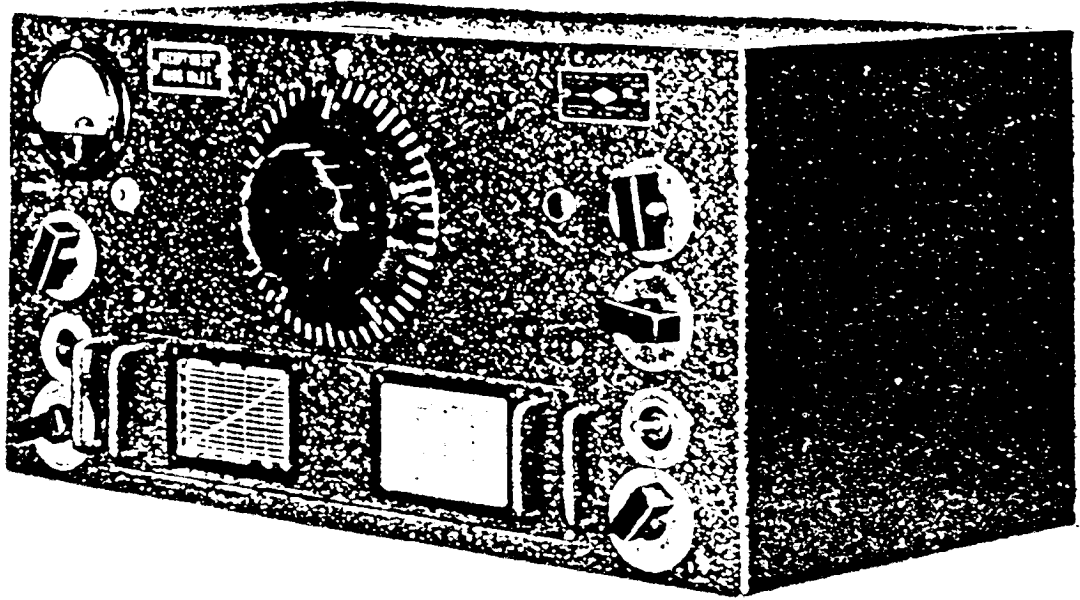

Figure 14. National HRO series of receivers (table models) in cabinet.

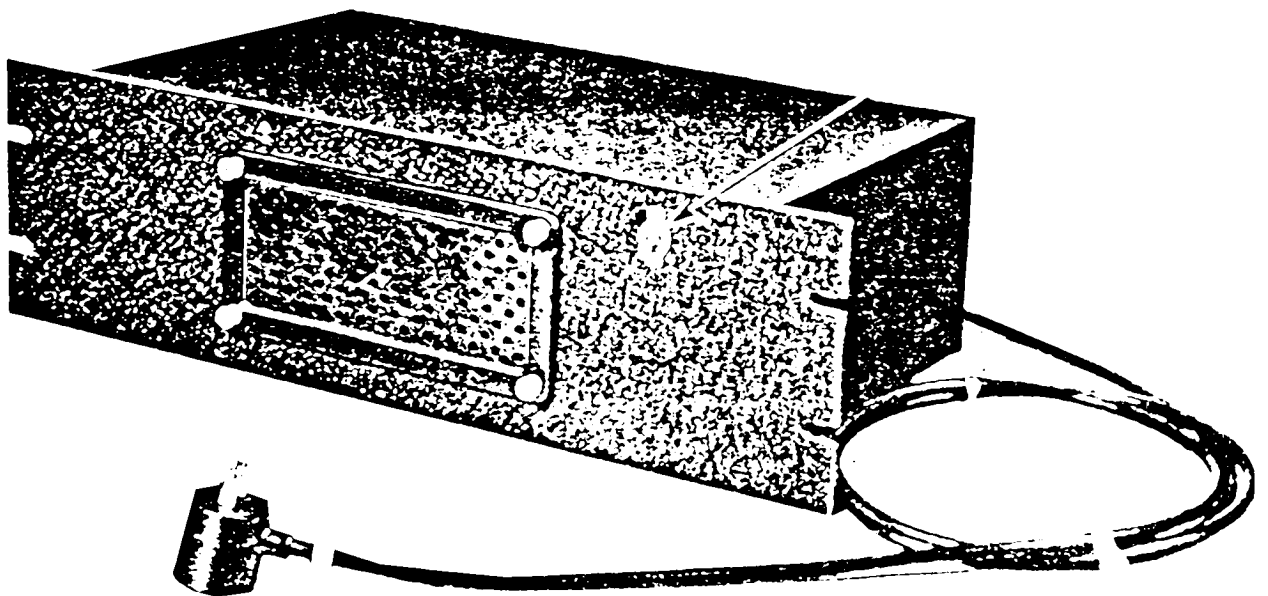

Figure 15. Power supply (National type SPU-697) (rectifier power unit, Navy type No. 20090).

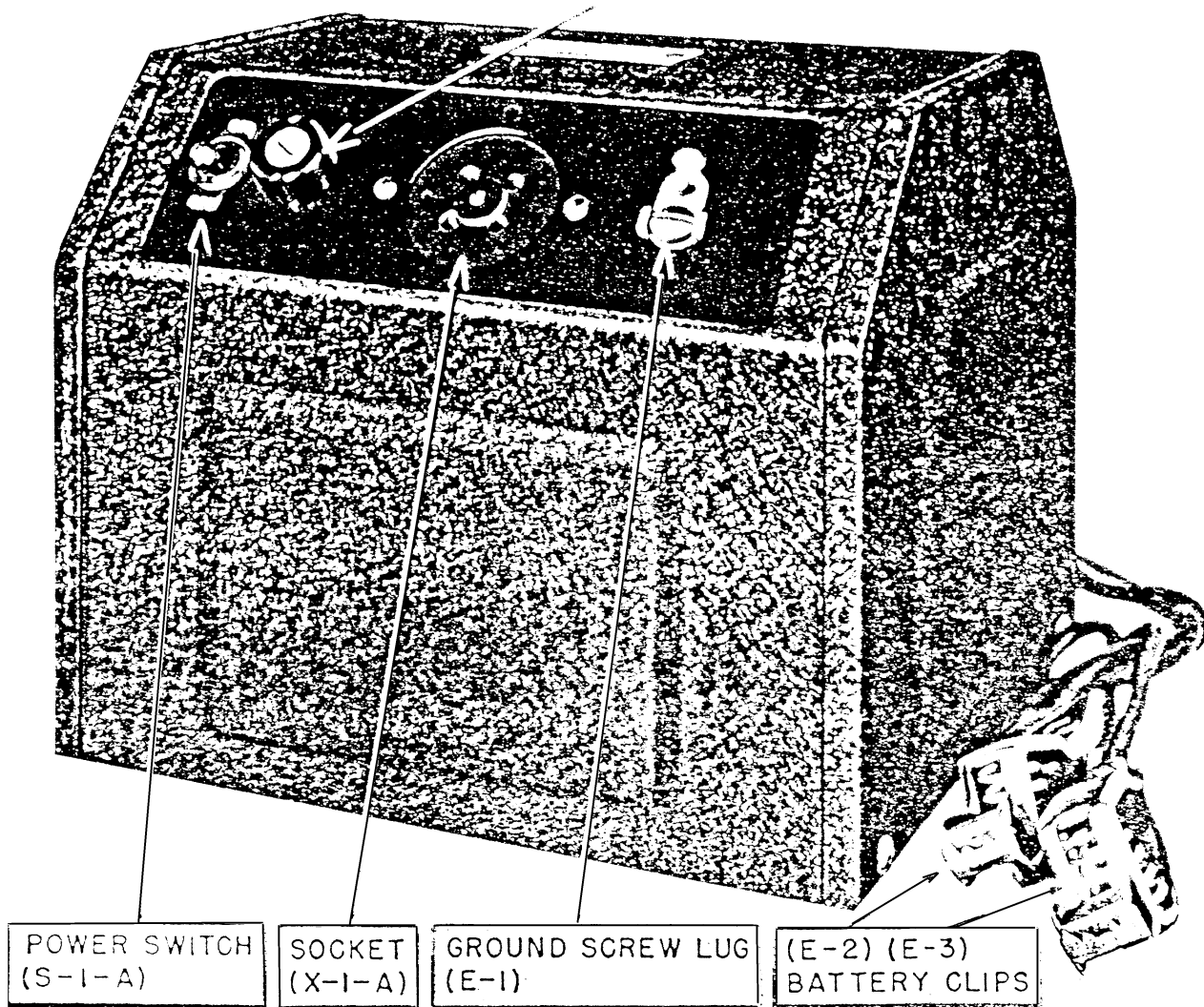

Figure 16. Power supply (National type 686-S).

8. Differences in Models, National HRO Series of Receivers

a. The National HRO series of receivers are divided into two basic groups: the HRO-senior series, and the HRO-junior series.

(1) The HRO-senior series (sometimes known as the HRO-series) embodies an S-meter, crystal filter circuit with phasing and selectivity controls, and coil sets A, B, C, and D which have a bandspread feature.

(2) The HRO-junior series is similar in the HRO-series but does not have the S-meter, bandspread feature, or the crystal filter and associated controls.

b. The HRO-series of receivers is further divided into two categories: the HRO and the HRO-5.

(1) The HRO-series uses bandspread coil sets A, B, C, and D. The following glass tubes are used:

V-11st r-f6D6
V-22d r-f6D6
V-31st detector6C6
V-4h-f oscillator6C6
V-51st i-f6D6
V-62d i-f6D6
V-72d detector, avc, 1st a-f6B7
V-8bfo6C6
V-9a-f output42

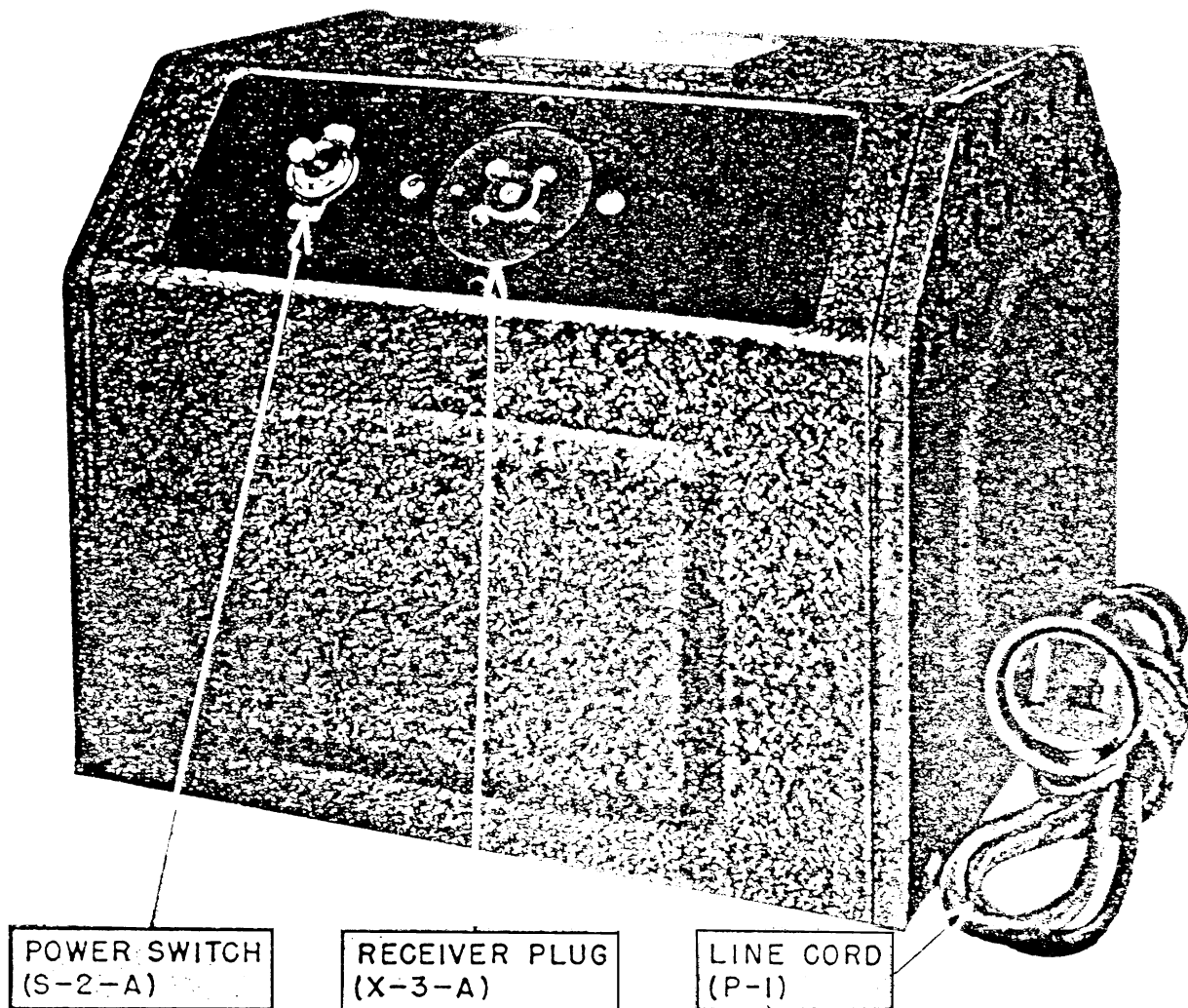

Figure 17. Power supply (National type 697).

(a) The HRO-M is basically the same as the HRO series. It uses glass tubes and a plug-in crystal filter. It does not have the bandspread feature.

(b) The HRO-MX is the same as the HRO-M except it has a built-in crystal unit.

(c) The HRO-M-RR is the same as the HRO-M but is supplied for mounting in a relay rack.

(d) The HRO-M-TM is an HRO-M equipped with a cabinet for table use.

(2) The HRO-5 series of receivers is a standard HRO receiver using metal tubes and

a circuit design almost identical to the other HRO series. The following tubes are used:

V-11st r-f	6K7
V-22d r-f	6K7
V-31st detector	6J7
V-4h-f oscillator	6J7
V-51st i-f	6K7
V-62d i-f	6K7
V-72d detector, avc, 1st a-f	6SQ7
V-8bfo	6J7
V-9a-f output	6V6GT/G

(a) The HRO-5T is the same as the HRO-5 and is supplied with a cabinet for table use.

(b) The HRO-5R is the same as the HRO-5 but is supplied for rack mounting.

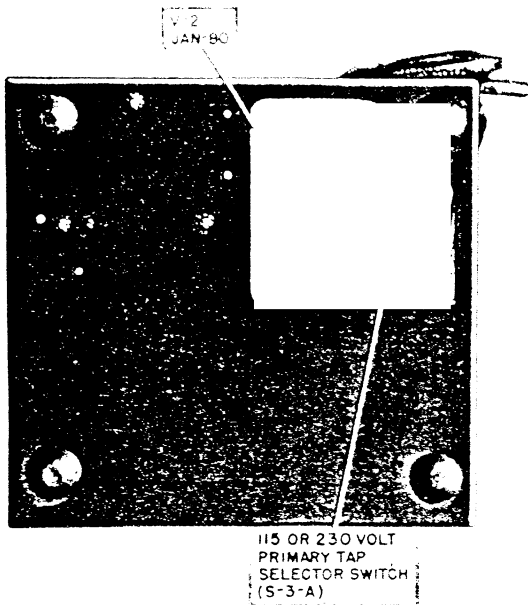

Figure 18. Power supply (National type 697) showing primary tap selector switch S-3-a—bottom view.

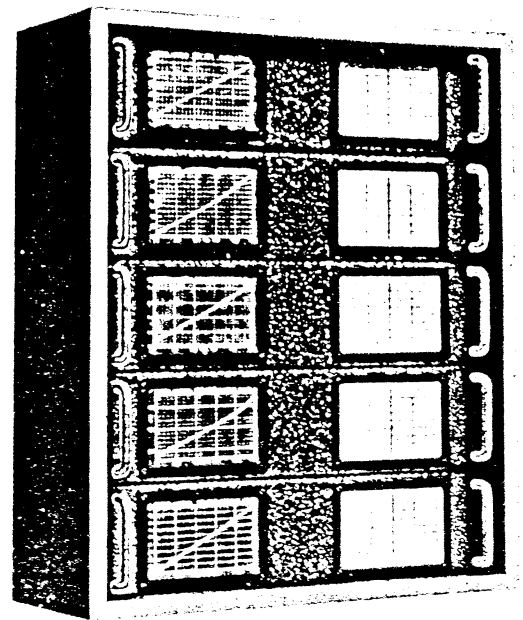

Figure 20. Coil box for five coil sets.

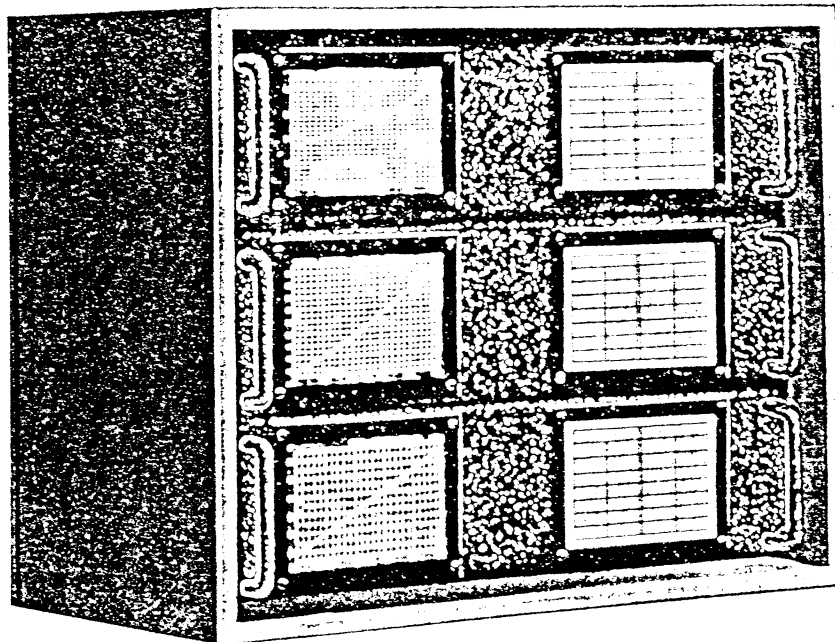

Figure 19. Coil box for three coil sets.

Section II. INSTALLATION

9. Siting

These receivers must be correctly situated if good performance is desired. In many instances, particularly where the receiver is part of a larger set, the necessary tactical and technical requirements for proper operation of the system as a whole will determine the receiver location. In any case, remember the following points:

a. The antenna should be high, and clear of surrounding objects.

b. The receiver should be situated away from power lines, generators, power units, or other unshielded electrical equipment.

c. Hills and other high places are better for radio reception. Avoid dips, valleys, hollows, and other depressions.

d. Trees and other dense foliage decrease radio reception.

10. Unpacking, Uncrating, and Checking

Be careful when unpacking or handling the equipment to prevent damage when not protected by the packing case. Do not apply pressure to the S-meter, case, knobs, or thin sheet metal sides of the cabinet. When unpacking the equipment follow the steps outlined below:

a. Place the packing case as near the operating location as is convenient.

b. Cut the steel straps.

c. Open the case by removing the nails with a nail puller. *Prying the sides off may result in damage to the equipment.*

d. Remove the top of the packing case and all protective wrappings.

e. Remove the receiver from its case and place it near its final location.

f. Check the contents of the case against the packing list. The packing list will be fastened to the outside of the case and protected by a waterproof envelope.

g. Exercise the precautions outlined above in uncrating other components.

11. Assembly for Operation

Cable connections of components used for operation of these receivers are shown in the cording diagram. (See fig. 21.)

Caution: When a loudspeaker is not used with any of the National HRO receivers, connect the speaker tip jacks together with a wire jumper. If this is not done before turning the B supply on, the audio output tubes may be damaged by excessive screen current. This precaution is not necessary with Radio Receiver R-140/FSM-1.

a. **TUBES.** Remove the tubes from the packing case and check their physical condition. (See fig. 22 for proper location of tubes on the chassis.) When inserting the tubes in their respective sockets, align the key on the aligning

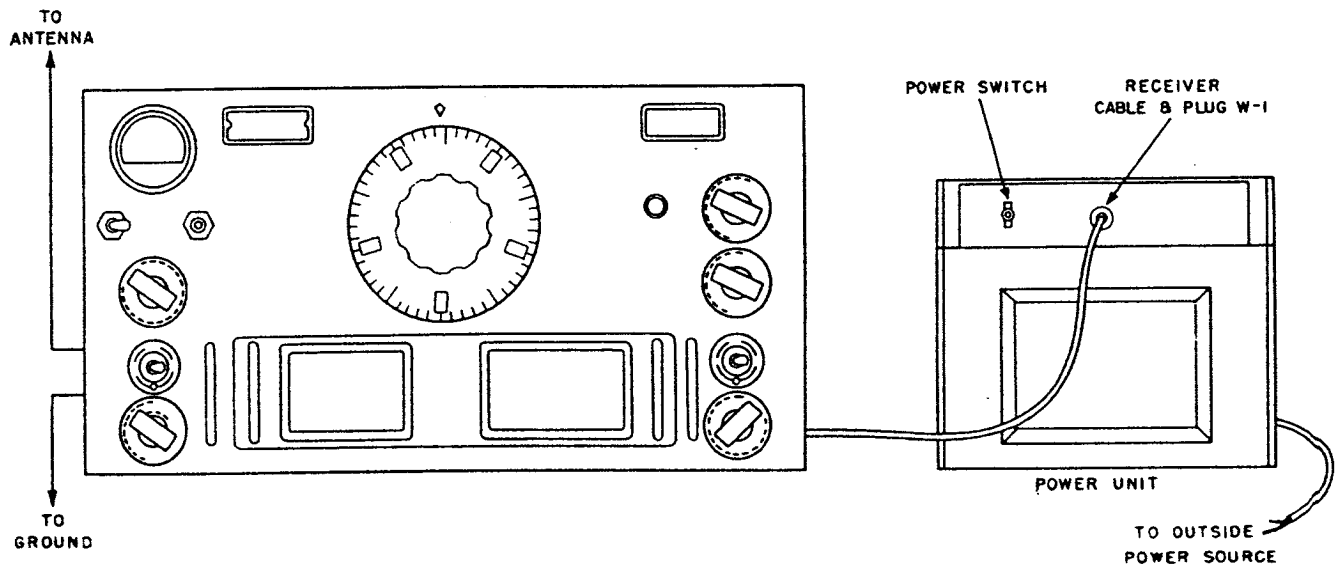

Figure 21. Receiver cording diagram.

TL123665

plug with the slot in the tube socket and push the tube straight down.

b. WIRING. (1) Power supply. Insert the receiver power plug into the power supply to be used, and plug the power supply into the appropriate power source. For this operation use a 6-volt direct current for Power Supply 686-S and SPU-686-S, and 110- to 120-volt, 50- to 60-cycle alternating current for Power Supply 697 and SPU-697 (rectifier power unit, Navy type No. 20090).

Caution: When using a power supply (National type 697) which has a primary selector switch for operation on either a 115- or 230-volt, 50- to 60-cycle alternating current, be sure this switch is in the proper position.

(2) *Antenna connections.* Single-wire or doublet types of antennas may be used with this receiver. The antenna binding posts are located on the left-hand side of the receiver.

(a) *Single-wire antenna.* When using a single-wire antenna, attach it to the binding post nearest the front panel and attach the short flexible lead to the remaining post, which is then connected to ground or chassis.

(b) *Doublet antenna.* When a doublet antenna is used, connect the antenna feeders or a balanced transmission line directly to the input terminals. *Do not use the flexible ground connection.* The input impedance of the receiver varies over the total frequency range but averages about 500 ohms.

c. COIL SETS. The proper coil set for the desired frequency must be installed in the receiver. Check the coil set in the receiver, and if it does not cover the desired frequency, pull it out by the handles. Select the correct coil set and install it by sliding it into the provided space. Make sure that the coil set is all the way in or the receiver will not operate properly.

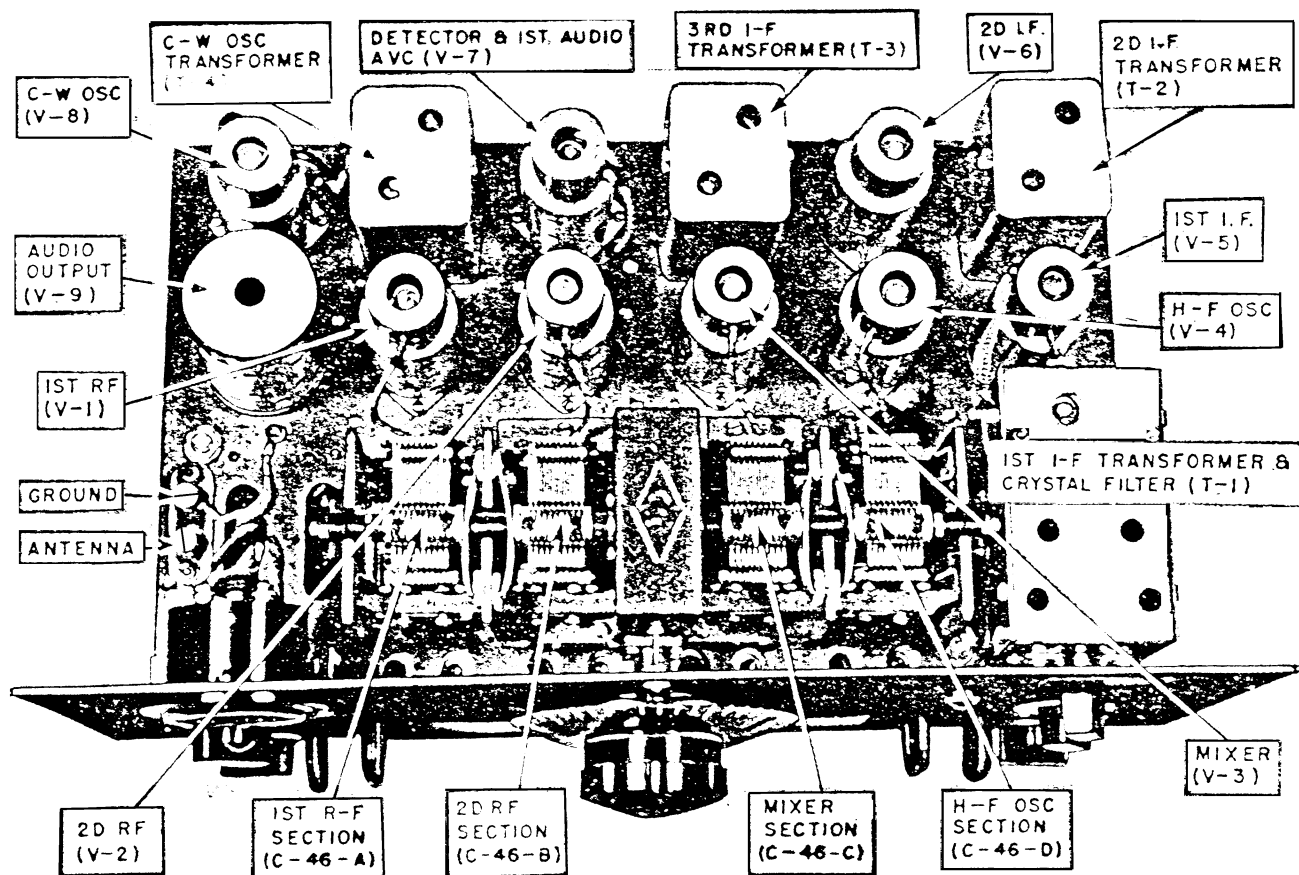

Figure 22. Location of tubes and components.

PART TWO

OPERATING INSTRUCTIONS

Note. For information on destroying the equipment to prevent enemy use, refer to the destruction notice at the front of this manual.

Section III. CONTROLS AND THEIR USE

12. Front Panel Controls (fig. 23)

The functions of the controls, S-meter, and the phone jack located on the front panel of the receiver, are described below.

a. **MAIN TUNING DIAL (K-1).** The main tuning dial is located in the center of the front panel. As the dial reading increases the frequency to which the receiver is tuned also increases. The frequency for each dial reading may be found by referring to the chart attached to the coil set plugged into the receiver. This type of dial is calibrated from 0 to 500 and may be read to one part in 500. The long scale length (12 feet) provides ease and accuracy in setting and calibration. The

dial mechanism drives a four-gang tuning capacitor (C-46-A, -B, -C, and -D) through a drive with a reduction ratio of 20 to 1. Backlash is eliminated by a spring-loaded split worm wheel for positive motion in either direction.

b. **SELECTIVITY CONTROL (K-2).** The selectivity control knob is located on the upper right-hand side of the front panel. Rotating the knob in either direction from a vertical position will increase selectivity. When the crystal filter (PHASING control) is not in use, the selectivity control acts as an ordinary intermediate-frequency (i-f) trimmer. When the crystal is in use, minimum selectivity is obtained when the pointer is nearly vertical and receiver background noise is greatest.

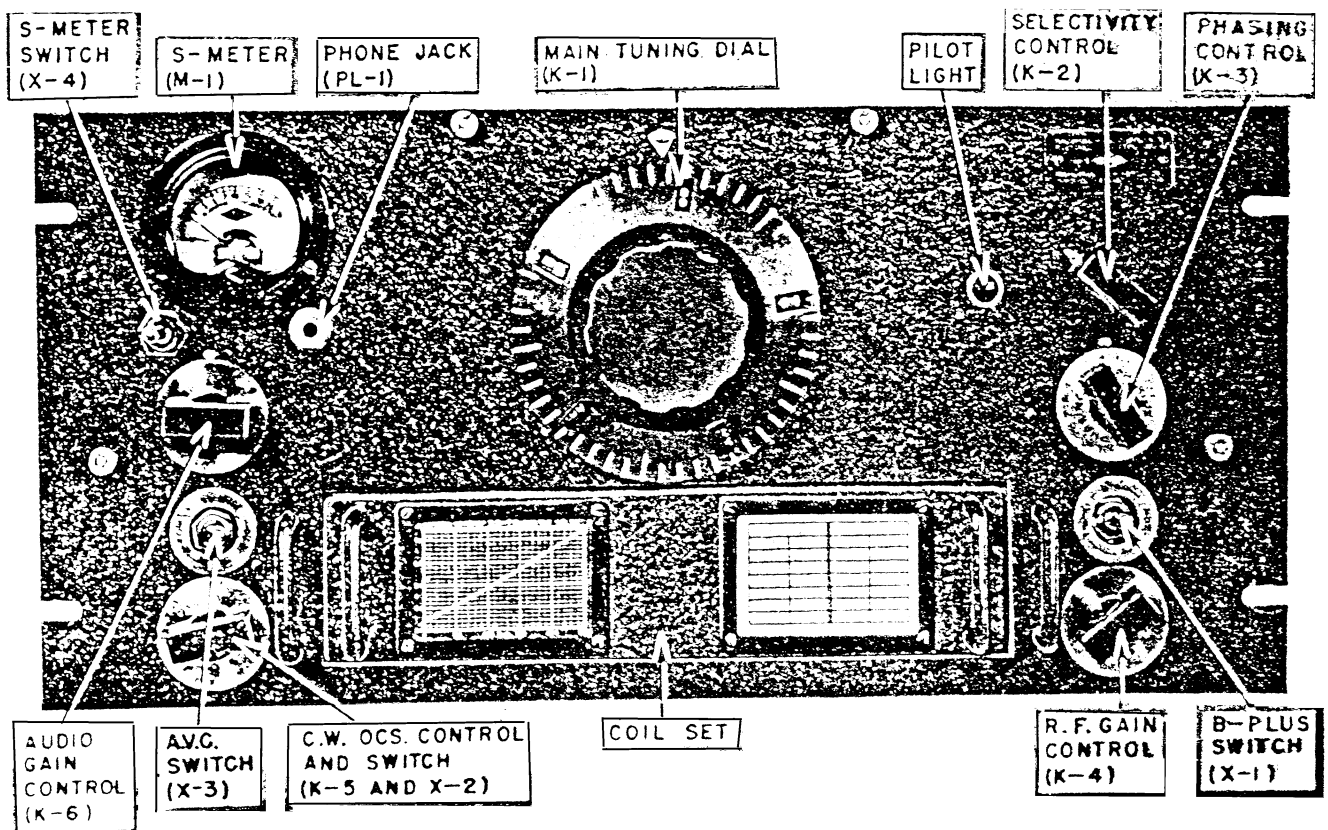

Figure 23. Front panel controls.

c. PHASING AND CRYSTAL FILTER CONTROL (K-3). The PHASING control and crystal filter switch are on the same knob, which is located directly beneath the selectivity control on the right side of the front panel. A calibrated circular scale numbered from 0 to 10 is attached to the panel directly under the knob. This control disconnects the crystal from the circuit when set at 0, and acts as a PHASING control with the crystal in operation at any setting between 1 and 10. It is used to balance the crystal bridge circuit in eliminating interfering signals.

d. B+ SWITCH (X-1). This two-position toggle switch is located directly beneath the phasing control knob. It is connected in the positive lead of the power supply, and acts as a standby switch during periods of transmission. It also serves to shut off the receiver *when changing coil sets*. When the switch is thrown to the right, the B-plus circuit is completed.

e. R.F. GAIN CONTROL (K-4). The R.F. GAIN control knob is located at the lower right side of the front panel. It is used to adjust the amplification of the second radio-frequency (r-f), the 1st i-f, and the second i-f stages. A circular scale calibrated from 1 to 10 is attached to the knob. Maximum sensitivity is obtained by rotating the knob to the extreme clockwise position, which is point 10 on the circular scale. With the knob in this position, all tubes function with maximum gain and minimum bias. Counterclockwise rotation of the knob increases bias and decreases amplification.

f. C.W. OSC. CONTROL (K-5 AND X-2). The C.W. OSC. control knob is located at the extreme lower left side of the front panel. This knob controls both the switch to connect the c-w oscillator into the circuit and the vernier oscillator tuning control, which is connected by a shaft to vary the capacitance of C-27 for oscillator tuning.

g. A.V.C. SWITCH (X-3). The A.V.C. switch is located directly above the C.W. OSC. control knob. It is a two-position toggle switch. The right position turns a-v-c action off and the left position puts the a-v-c circuit into operation. The a-v-c action must not be used when the c-w oscillator is in operation, as the cir-

cuits are blocked and the receiver becomes insensitive.

h. AUDIO GAIN CONTROL (K-6). The AUDIO GAIN control knob is located beneath the S-meter dial and above the A.V.C. switch, on the left side of the front panel. A circular calibrated scale is attached to the control knob. Clockwise rotation of the knob increases the volume level of the signal at both the phone jack and the loudspeaker terminals.

i. S-METER AND S-METER SWITCH (X-4).

(1) The S-meter switch for connecting the S-meter into the circuit is located in the upper left-hand corner of the control panel, just below and to the left of the S-meter. This switch completes the meter circuit when pushed to the right.

(2) The S-meter is used to measure the strength of an incoming signal when the receiver is set for voice with the automatic volume control turned on. With no signal input, the meter should read 0 when the R.F. GAIN control is set at about 9.5.

j. PHONE JACK (PL-1). The phone jack is located just below and to the right of the S-meter. When a phone plug is inserted into the jack, the loudspeaker is automatically silenced.

Section IV. OPERATION

13. Starting Procedure

When the receiver has been properly installed and connected, check to make sure the proper coil set is in place, then set the power switch on the front panel of the power supply to the ON position and allow the set to warm up for a few minutes.

14. Voice Reception

a. Turn the B-PLUS switch to the ON position.

b. Set the A.V.C. switch in the ON position.

c. Turn the C.W. OSC. control to the OFF position (extreme counterclockwise setting of the knob).

d. Set the AUDIO GAIN control to 5.

e. Set the R.F. GAIN control to 9.5.

f. Set the selectivity control at half scale.

g. Turn the PHASING control to 0.

h. Turn the S-meter switch to the ON position.

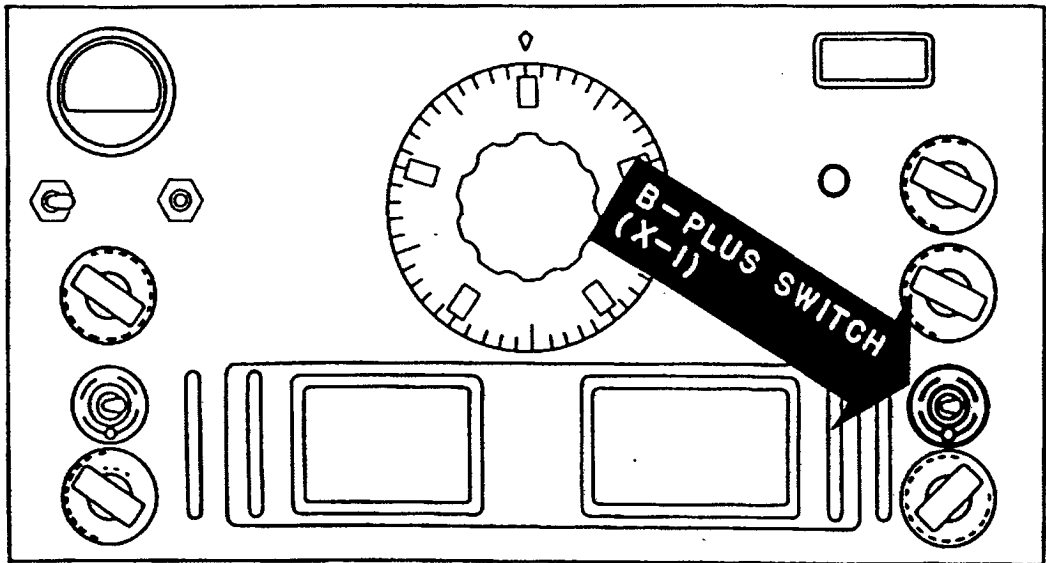

TL123725

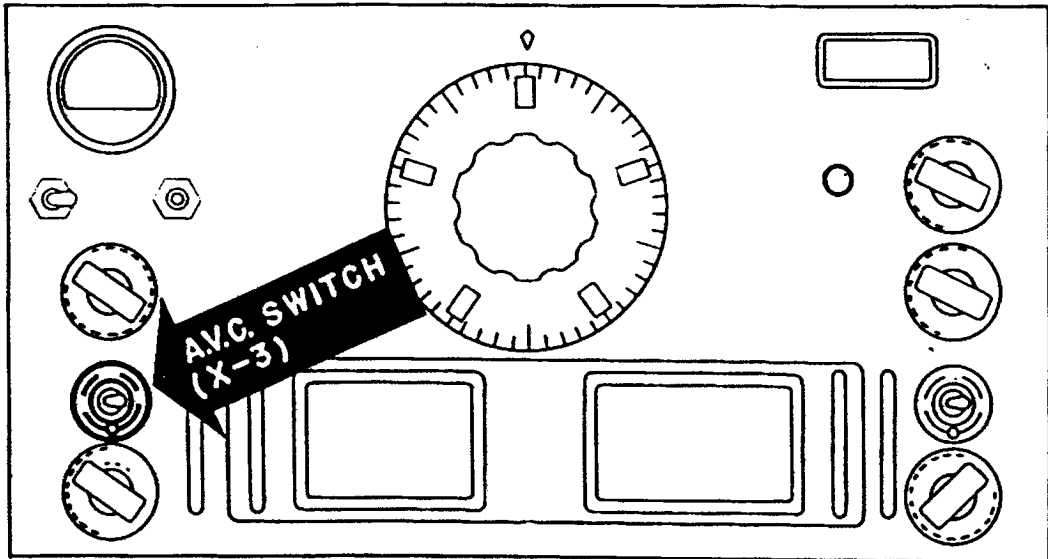

TL123755

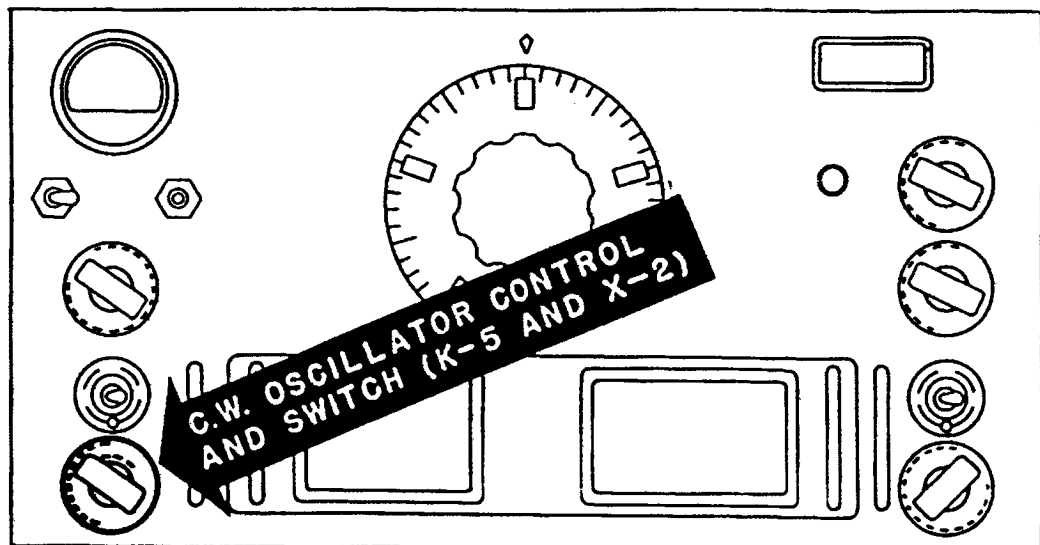

TL123745

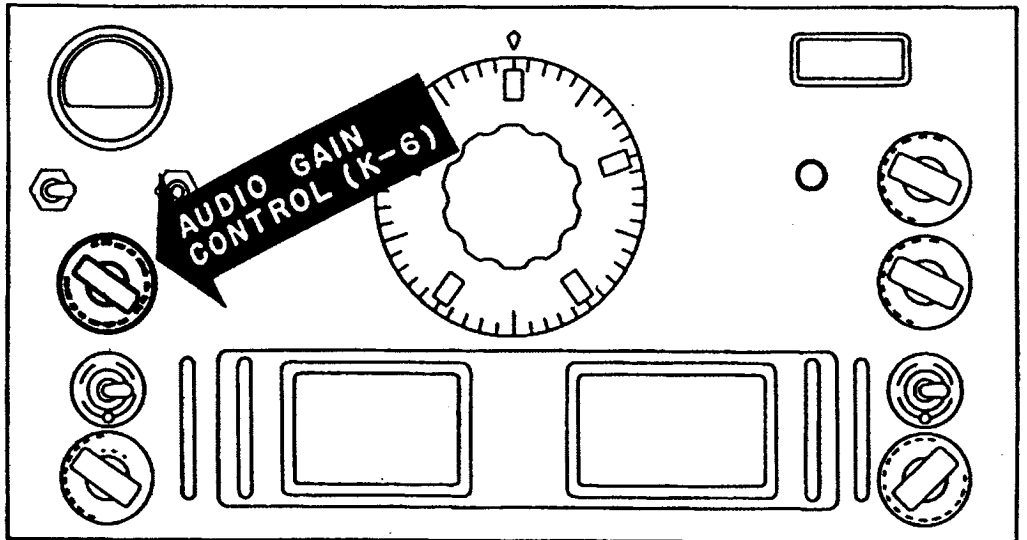

TL123765

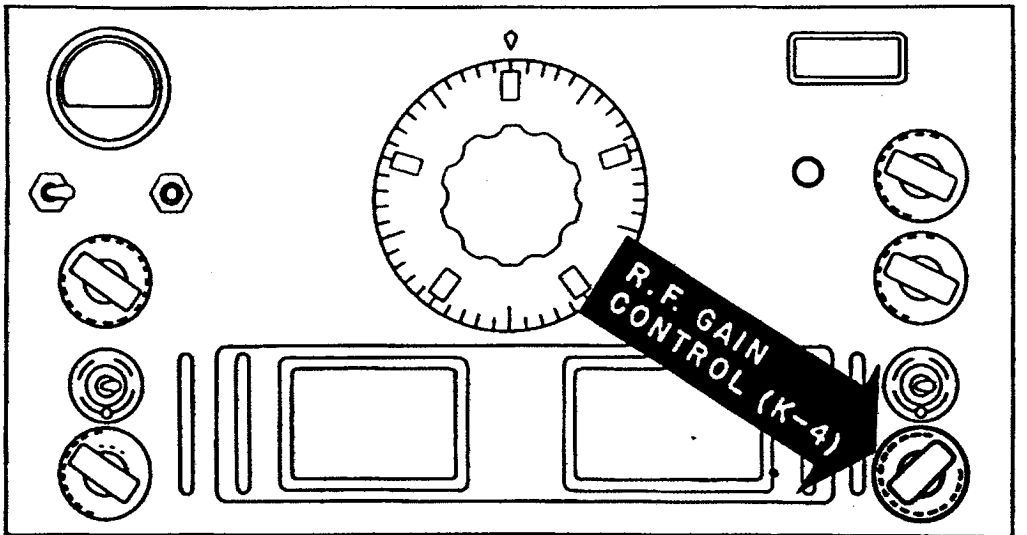

TL123735

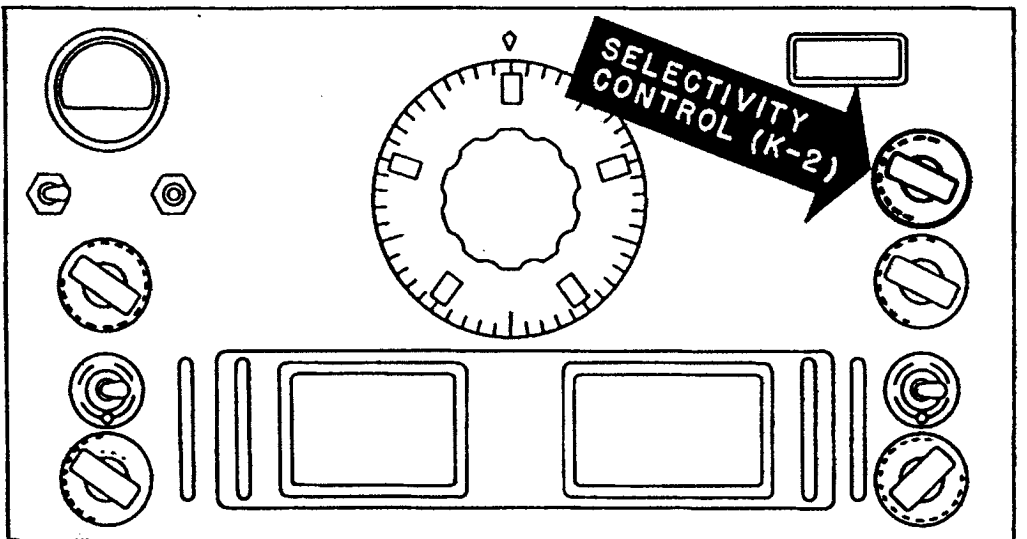

TL123705

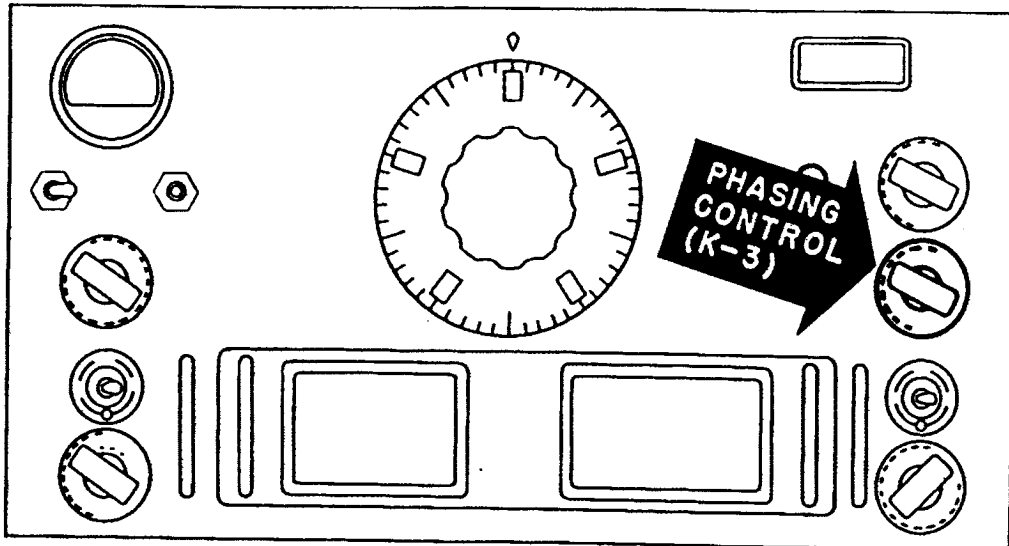

TL123715

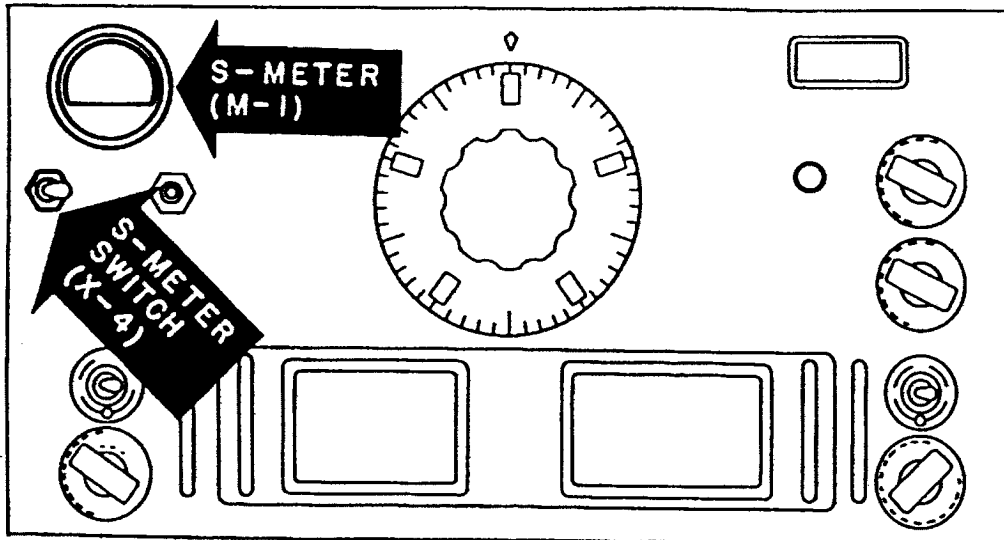

TL123775

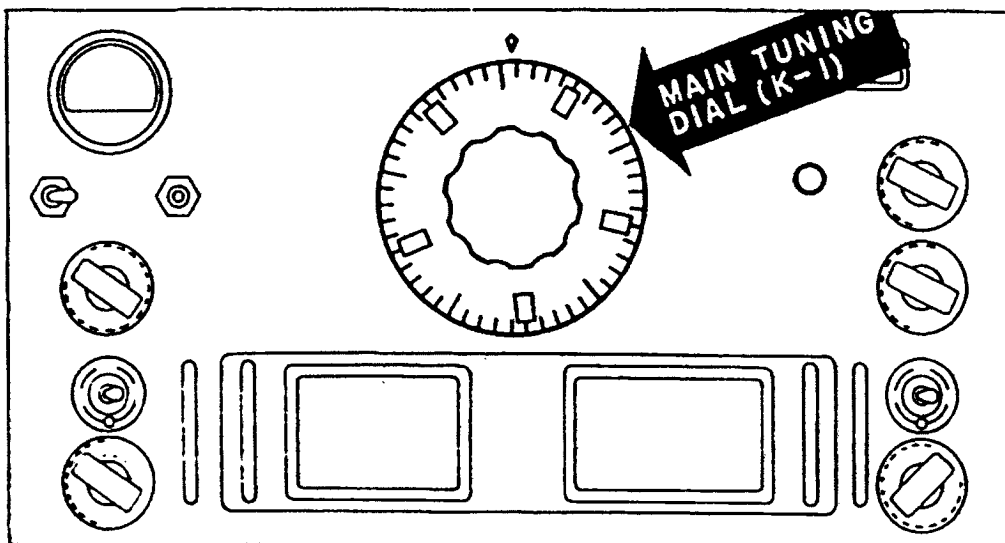

TL123695

i. Set the main tuning dial for a known signal frequency, and tune carefully for maximum S-meter deflection. Maximum sensitivity is obtained with the selectivity control set near the center of its range. When receiving weak signals the best signal-to-noise ratio is obtained by retarding the AUDIO GAIN control and advancing the R.F. GAIN control to a point as near maximum as receiving conditions permit. Take care to avoid overloading the r-f and mixer stages under these conditions especially when signals are very strong. *Shut off the S-meter when the R.F. GAIN control is retarded from a 9.5 setting.* An overload will be indicated by excessive audio distortion. When the noise level is high, the R.F. GAIN control may be retarded to limit the over-all sensitivity of the receiver to a definite maximum; however, *full a-v-c action cannot be obtained unless the R.F. GAIN control is fully advanced.*

15. C—W or Tone Operation

a. Tuning for a c-w or tone signal is essentially the same as for voice, except for control settings. Set the controls as shown in the following table:

Control Settings for C-W or Tone Reception

Control	Setting
B-PLUS switch	ON
A.V.C. switch	OFF
C.W. OSC. switch	7 for c-w OFF for tone ¹
AUDIO GAIN control	5
R.F. GAIN control	Advance for signal
Selectivity control	Half scale
PHASING control	0
S-meter switch	OFF

b. The R.F. GAIN control may cause an i-f and second detector overload if advanced too far. This is indicated by a change in pitch of the c-w beat note over the duration of a code character, or by excessive thumping.

c. The best recommended setting of the C.W. OSC. control is that which is closest to the intermediate frequency of the receiver. This setting will be approximately between 8 and 10 on the C.W. OSC. control scale. The oscillator is progressively detuned from the inter-

¹ For weak tone signals it may be advantageous to turn the C.W. OSC. control on.

mediate frequency as the setting is brought toward 0. The extent of such adjustment may be determined by listening to the pitch of background and circuit noises. When the pitch of the beat note is between 2,000 and 3,000 cycles per second (cps) the receiver will have definite single-signal properties. This means that the audio beat note of the signal received will be noticeably louder on one side of the carrier, and can be very useful in locating a weak signal as this utilizes the maximum sensitivity of the receiver.

16. Reception with Crystal Filter

The crystal filter is useful in eliminating interference and heterodynes, and to adjust the selectivity of the receiver. It is most effective for c-w reception but may also be used for voice or tone.

a. VOICE OR TONE RECEPTION. Switch the crystal filter into the circuit by turning the PHASING control knob (K-3) from 0 to 1.

(1) A slight loss of receiver gain will result and it will be necessary to advance both the AUDIO GAIN and R.F. GAIN controls to compensate for this loss.

(2) After satisfactory adjustment of gain, turn the PHASING control to the center of its range. This will effectively remove its action from the band of frequencies being received.

(3) Adjust the selectivity control for minimum selectivity by turning to a position where background noise is loudest.

(4) Tune the receiver for the signal as described in paragraph 15.

(5) To overcome extremely heavy interference, increase the selectivity by turning the selectivity control in either direction from its minimum selectivity position. Under these conditions tuning is very critical, therefore be careful to properly set the main tuning dial.

(6) Heterodynes may be suppressed by adjusting the PHASING control. The resultant setting will depend on whether the frequency of the undesired signal is above or below the frequency of the tuned signal.

b. C-W RECEPTION. Crystal filter operation for c-w reception is similar to that for tone or voice, with the exception that maximum selectivity may be used without the loss of intelligibility experienced in tone or voice reception.

(1) Be careful when maximum selectivity is used, since tuning is very critical at this stage. When the receiver is slowly tuned across the carrier of a received signal, the beat note produced will be very sharply peaked in output at a particular audio pitch. This peak in response indicates the correct receiver dial setting. The setting of the C.W. OSC. control must provide a beat note peak well within audibility so that receiver peak response may be readily observed. A C.W. OSC. dial setting near 7 is recommended.

(2) After the receiver has been correctly tuned, the pitch of the beat note peak may be adjusted by means of the C.W. OSC. control to provide a pleasant audio tone. Under these conditions the receiver will exhibit pronounced single-signal properties, which may be demonstrated by tuning the receiver dial to the other side of zero beat so that the pitch is the same as before and observing the marked reduction in output.

(3) The operation of the PHASING control in suppressing an undesired signal is the same for c-w reception as for tone or voice.

17. Stopping Procedure

a. To turn the receiver off temporarily while transmitting or changing coil sets, turn the B-PLUS switch OFF.

b. To turn the receiver off for longer periods of time, turn the power switch on the front panel of the power supply OFF.

Section V. EQUIPMENT PERFORMANCE CHECK LIST

18. Purpose and Use of Check List

a. GENERAL. The equipment performance check list (par. 19) will help the operator determine whether the receivers and associated power supplies are functioning properly. The check list gives the item to be checked, the conditions under which the item is checked, the normal indications of correct operation, and the corrective measures to be taken. Check all items both in starting and during operation.

(See par. 19.) Items on this list should be checked at least once during a normal operating period.

b. ACTION OR CONDITION. For some items, the information given in the action or condition column consists of the settings of various switches and controls under which the item is to be checked. For other items it represents an action that must be taken to check the normal indication given in the normal indication column.

c. NORMAL INDICATIONS. The normal indications listed include the visible and audible signs that the operator will perceive when he checks the items. If the indications are not normal, the operator should apply the recommended corrective measures.

d. CORRECTIVE MEASURES. The corrective measures listed are those the operator can make without turning the equipment in for repairs. Reference to paragraphs 55 through 69 in the table (par. 19) indicates that the correction of the trouble cannot be effected during operation, and that trouble shooting by an experienced repairman is called for. If the set is completely inoperative or if the recommended corrective measures do not yield results, trouble shooting is necessary. However, if the tactical situation requires that the communication be maintained and if the set is not completely inoperative, the set must be kept in operation as long as it is possible to do so.

e. ITEMS 1 TO 7. Check items 1 to 7 each time the equipment is put into operation.

f. ITEMS 8 TO 18. The operator should familiarize himself with the operation of the receiver so that he knows the characteristics of its reception of normal signals. By becoming familiar with the operation of the receiver, the operator will know the normal position of the VOLUME control. This will aid in an approximate determination of the sensitivity and amplification of the receiver.

g. ITEM 19. Check item 19 when using the beat-frequency oscillator.

h. ITEMS 20 AND 21. Check items 20 and 21 when turning off the equipment.

19. Equipment Performance Check List

POWER SUPPLY

	Item No.	Item	Action or condition	Normal indications	Corrective measures
P R E P A R A T O R Y	1	Power cable and Plug W-1	Insert four-prong plug into receptacle on power supply		
	2	Line switch (S-2-a or S-1-a) on power supplies	Turn to OFF position		
	3	Primary tap selector switch (S-3-a). (Power Supply 697, or SPU-697 only).	Check setting for line voltage		

RECEIVER

P R E P A R A T O R Y	4	Receiver antenna connections	Check for clean connection and proper contact		
	5	B- switch (X-1)	Throw to OFF position		
	6	Power unit line cord	Plug into proper power source		
	7	Loudspeaker or headset	Plugged in or connected..		
	8	Speaker terminals ..	Check for jumper if using phones (not necessary with R-140/FSM-1) ...		

POWER SUPPLY

S T A R T	9	Power switch (S-1-a or S-2-a)	Throw to ON position....	Pilot lamp goes on and tubes warm up	Check line plug power cable W-1 and connections. Examine switch for faulty contact and test for faulty rectifier tube V-2 in power unit or see paragraphs 55 through 69.
-----------------------	---	-------------------------------------	--------------------------	--	--

RECEIVER

S T A R T	10	Coil set	Insert proper coil set into receiver receptacle	Desired frequency is within range of coil set	Change to correct coil set.
	11	B+ switch (X-1)	Throw to ON position	Background noise, some S-meter motion	R.F. or AUDIO GAIN controls not advanced sufficiently, speaker or phones not connected, or see paragraphs 55 through 69.

RECEIVER (Continued)

	Item No.	Item	Action or condition	Normal indications	Corrective measures
E Q U I P M E N T P E R F O R M A N C E	12	Main tuning dial (K-1)	Tune for signal	Signal response in loudspeaker or phones	Check contact fingers on coil sets and brush-board. Check tubes. Check for coil set of correct frequency. See that AUDIO and R.F. GAIN controls are sufficiently advanced or see paragraphs 55 through 69.
	13	AUDIO GAIN control (K-6)	Set at 0	Weak or no signal	Advance or retard control for suitable volume.
	14	R.F. GAIN control (K-4)	Set at 10	Very strong signal	
			Set at 0	Weak or no signal	Advance for suitable volume.
			Set at 10	Increased volume or distortion on strong signals	Retard control or turn C.W. OSC. switch OFF and A.V.C. switch ON.
15	A.V.C. switch (X-3)	Throw to ON position....	For ON position S-meter should give suitable reading for tuned signal. Overload distortion eliminated. Very weak c-w signals (receiver blocked). OSC. ON	Turn to OFF for receiving continuous wave or see paragraphs 55 through 69.	
		Throw A.V.C. switch to OFF position	S-meter should not read more than two divisions with no signal input and R.F. GAIN control at 9.5. Sensitivity for c-w signals should increase.	Test tube V-7 if S-meter deflects more than two divisions with no signal, or refer to paragraphs 55 through 69.	

RECEIVER (Continued)

	Item No.	Item	Action or condition	Normal indications	Corrective measures
E Q U I P M E N T P E R F O R M A N C E	16	S-meter switch (X-4)	Throw to ON position...	Pointer should flicker and deflect when receiver is tuned for a signal....	Check antenna, tubes, and power source, or see paragraphs 55 through 69.
			Throw to OFF position..	S-meter should indicate 0 at all times	Check S-meter switch (X-4) for defect.
	17	PHASING control	Advance as necessary...	Elimination of interfering signals. Slight loss of gain and suppression of background noise.	See paragraphs 55 through 69 for information on corrective measures.
	18	Selectivity control	Turn from vertical position in either direction	Selectivity should increase	See paragraphs 55 through 69.
	19	C.W. OSC. control..	Throw to ON position and advance for beat note	With automatic volume control on, blocking and a lack of sensitivity should result. With automatic volume control off, beat note should be heard with the tuned signal. Note should vary in pitch according to the setting of the C.W. OSC. control knob.	See paragraphs 55 through 69.
S T O P	20	B+ switch	Throw to OFF position ..	No signal in phone or loudspeaker. No reading on S-meter	

POWER SUPPLY

S T O P	21	Power switch	Throw to OFF position...	Pilot lamp goes out, no signal..	
------------------	----	--------------------	--------------------------	----------------------------------	--

PART THREE

MAINTENANCE INSTRUCTIONS

Section VI. PREVENTIVE MAINTENANCE TECHNIQUES

20. Meaning of Preventive Maintenance

Preventive maintenance is a systematic series of operations performed at regular intervals on equipment, when turned off, to eliminate major break-downs, unwanted interruptions in service, and to keep the equipment operating at top efficiency. To understand what is meant by preventive maintenance, it is necessary to distinguish between preventive maintenance, trouble shooting, and repair. The prime function of preventive maintenance is to *prevent break-downs* and, therefore, the need for repair. On the other hand, the prime function of trouble shooting and repair is to locate and correct *existing* defects. The importance of preventive maintenance cannot be overemphasized. A system of radio communication depends on the performance of every set. It must be *ready to go* on the air when it is needed, and it must operate *efficiently*. Therefore, it is vitally important that radio operators and repairmen maintain their radio sets properly.

Note. The operations in paragraphs 20 through 45 are first and second echelon (organization operators and repairmen) maintenance. Some operations in paragraphs 46 through 54 are higher echelon.

21. Description of Preventive Maintenance Techniques

a. GENERAL. Most of the electrical parts used in Radio Receiver R-140/FSM-1 (National HRO series of receivers) and associated power supplies require routine preventive maintenance. This preventive maintenance varies. Hit-or-miss techniques cannot be applied. This section of the manual contains these specific instructions to guide personnel assigned to perform the six basic maintenance operations: Feel, Inspect, Tighten, Clean, Adjust, and Lubricate. Throughout this manual the

lettering system for the six operations will be as follows:

- F — Feel.
- I — Inspect.
- T — Tighten.
- C — Clean.
- A — Adjust.
- *L — Lubricate.

The first two operations show if the other four are needed. Selection of operations is based on a general knowledge of field needs. For example, the dust encountered on dirt roads during cross-country travel filters into the equipment no matter how much care is taken to prevent it. Rapid changes in weather (such as heavy rain followed by blistering heat), excessive dampness, snow, and ice tend to cause corrosion of exposed surfaces and parts. Without frequent inspections and the necessary tightening, cleaning, and lubricating operations, equipment becomes undependable and subject to break-down when it is needed most.

b. FEEL. The feel operation is used most often to check rotating machinery, such as dynamotors, blower motors, and drive motors, also to determine whether electrical connections and bushings are overheated. Feeling will show the need for lubrication or the existence of other defects requiring correction. The maintenance man *must* become familiar with the normal operating temperatures of motors, transformers, and other parts, to recognize signs of overheating.

Note. It is important to perform the feel operation as soon as possible after shut-down and always before any other maintenance is done.

c. INSPECT. Inspection is the most important operation in preventive maintenance. A careless observer will overlook evidences of minor trouble. Although these defects may not at the moment interfere with the performance of the equipment, invaluable time and effort can be saved if they are corrected *before* they lead to

* The lubricate operation does not apply to this equipment.

major and costly break-downs. To be able to recognize the signs of a defective set, make every effort to become thoroughly familiar with indications of *normal* functioning. Inspection consists of *carefully* observing all parts of the equipment, noticing their color, placement, state of cleanliness, etc. Inspect for the following conditions:

(1) Overheating, as indicated by discoloration, blistering, or bulging of the parts or surface of the component; leakage of insulating compounds; and oxidation of metal contact (bearing) surfaces.

(2) Placement, by observing that all leads, cabling, and shafts are in their original positions.

(3) Cleanliness, by carefully examining all recesses in the receiver and power unit for accumulation of dust, especially between connecting terminals. Parts, connections, and joints should be free of dust, corrosion, and other foreign matter. In tropical and highly-humid areas, look for fungus growth and mildew.

(4) Tightness, by testing any connection or mounting which appears to be loose.

d. TIGHTEN, CLEAN, AND ADJUST. These operations explain themselves. Specific procedures to be followed in performing them are given wherever necessary throughout paragraphs 20 through 54.

Caution: Screws, nuts, and bolts *should not be tightened carelessly*. Fittings tightened beyond the pressure for which they were designed will be damaged or broken. Whenever a loose connection is tightened, it should be moistureproofed and fungiproofed again by applying the varnish with a small brush. (See pars. 46 through 54 for details of moistureproofing and fungiproofing.)

e. LUBRICATE. Lubrication is not needed on Radio Receiver R-140/FSM-1 and associated power supplies.

22. Vacuum Tubes

Note. Avoid doing work on tubes immediately after shut-down. *Severe burns may result* from contact with the envelopes of hot tubes.

a. INSPECT (I). (1) Inspect glass or metal tube envelopes, tube caps, and tube connector clips for accumulation of dirt and for corro-

sion. Tubes with loose plates, grid caps, or envelopes should be replaced if possible.

(2) Examine the spring clips that make contact with the grid caps for corrosion and loss of tension with resulting looseness. Check the condition of wires soldered to the spring clips. The wires should be free of frayed insulation or broken strands.

(3) Inspect the firmness of tubes in their sockets. Make the inspection by pressing the tubes down in the sockets and testing them in that position, *not* by partially withdrawing the tubes and jiggling them from side to side. Movement of a tube tends to weaken the pins in the base and unnecessarily spread the contacts in the sockets. Inspect the sockets at the time the tubes are removed.

(4) Be careful when removing a tube from its socket. *Never jar a warm tube.* Always remove connections to grid caps *before* starting to take out tubes.

b. TIGHTEN (T). Tighten all loose connections to the tube sockets or to the tubes. If the connections are dirty or corroded, clean them before tightening. When tightening locknuts that hold the sockets to the insulated bushings, do not apply excessive pressure. Too much pressure will crack the bushings.

c. ADJUST (A). Adjust loose tube connector clips. Do not flatten tube connector clips during adjustment. Flattened clips do not make adequate contact with the surface of the tube cap. If the clip is made of thin metal, it can be adjusted by gently compressing it with the fingers. If it is made of heavy-gauge metal, suitable pressure can be applied with a pair of long-nose pliers.

d. CLEAN (C). (1) Clean the tubes, if necessary. Tubes operated at high voltages and with exposed plate and grid connections must be kept free of dirt and dust because of possible leakage between grid and plate terminals. In contrast, tubes operating at low voltages and not having exposed grid and plate caps do not require frequent cleaning. However, do not permit dirt to accumulate on low-voltage tubes.

(2) Remove dust and dirt from the glass or metal envelopes with a clean, lint-free, dry cloth. If proper care is used, the grid and plate caps may be cleaned with a piece of No. 0000 sandpaper by wrapping the paper

around the cap and *gently* rubbing the surface. Excessive pressure is not needed; nor is it necessary to grip the cap tightly. Wipe the cap with a clean dry cloth.

(3) When tube sockets are cleaned and the contacts are accessible, fine sandpaper may be used to remove corrosion, oxidation, and dirt.

23. Capacitors

a. INSPECT (I). (1) Inspect the terminals of large fixed capacitors for corrosion and loose connections. Carefully inspect the mountings to discover loose mounting screws, studs, or brackets. Examine the leads for poor insulation, cracks, and evidences of dry rot. Cut away frayed strands on the insulation. If the wire is exposed, wrap it with friction tape. See that the terminals of the capacitors are not cracked or broken.

(2) Thoroughly inspect the case of each large fixed capacitor for leaks, bulges, and discoloration.

(3) Inspect the plates of variable capacitors for dirt, dust, or lint. Examine the movable set of plates for signs of damage or misalignment that would cause them to touch the fixed plates during tuning. Rotate the movable plates, using the panel tuning control, and thus check for proper operation of the capacitor.

b. TIGHTEN (T). Tighten loose terminals, mountings, and connections on the capacitors, when necessary. Be careful not to break the bushing or damage the gasket.

c. CLEAN (C). (1) Clean the case of fixed capacitors, the insulating bushings, and dirty or corroded connections. The capacitor cases and bushings can usually be cleaned with a dry cloth. However, if the deposit of dirt is hard to remove, moisten the cloth in a solvent, dry-cleaning.

(2) Clean the plates of variable capacitors with a small brush, to remove all dust and lint.

d. LUBRICATE (L). The bearings of variable capacitors are usually of the ball-bearing type, lubricated and sealed at the factory. These bearings will *not* need relubrication during the life of the equipment.

24. Resistors

a. GENERAL. Various types of resistors are used in Radio Receiver R-140/FSM-1 (Na-

tional HRO series of receivers) and their power supplies. The connections to the various resistors are either of the pigtail or the solder-lug type.

b. INSPECT (I). Inspect the coating of the vitreous-enameled resistors for signs of cracks and chipping, especially at the ends. Examine the bodies of all types of resistors for blistering, discoloration, and other indications of overheating. Inspect leads and all other connections for corrosion, dirt, dust, looseness, and broken strands, in the connecting wires. Check the security of all mountings. Do not attempt to move resistors with pigtail connections, as there is danger of breaking these connections at the point where they enter the body of the resistor. Such defects cannot be repaired.

c. TIGHTEN (T). Tighten resistor connections and mountings whenever they are found loose. If a resistor is allowed to remain loose, vibration may break the connection or damage the body.

d. CLEAN (C). (1) Clean all carbon resistors with a small brush.

(2) The vitreous-enameled resistors must be kept clean to avoid leakage between the terminals. Wipe them with a dry cloth. However, if the dirt deposit is unusually hard to remove, use dry-cleaning solvent (SD).

(3) Resistors with discolored bodies cannot be cleaned. Discoloration indicates that there has been overloading and overheating at some-time prior to the inspection. The discoloration is probably due to circuit trouble which requires analysis and correction. Trouble-shooting procedures are described in paragraphs 55 through 69.

25. Bushings and Insulators

a. DESCRIPTION. (1) Insulated bushings are used in the high-voltage and r-f circuits. They are constructed of ceramic material with a glazed surface. Because an insulator is no better than its surface, deposits of foreign substances on the surface will materially reduce the insulation value of the bushing. Therefore, it is very important that all bushings used in the high-voltage circuits be inspected frequently.

(2) Insulating bushings are used for high-voltage terminals of capacitors, and for r-f

circuits. The condition of insulator bushings that are used solely as supports is not too critical, but the condition of bushings used as high-voltage insulators is extremely important.

b. **INSPECT (I)**. (1) Inspect the physical condition of the insulator bushings. They should be clean and without cracks or chips. A highly glazed insulator may develop fine-line surface cracks where moisture and dust will accumulate and eventually form a leakage for a high-voltage flash-over.

(2) As a rule, the bushings are held in position with nuts screwed onto the threaded conductors. These can be replaced very easily. If replacement is not possible because of a shortage of supplies, clean the defective bushing thoroughly with dry-cleaning solvent (SD). Sometimes it is difficult to see dust on a glazed surface. A satisfactory check can be made by sliding a clean finger across the bushing.

c. **TIGHTEN (T)**. The procedure to be used in tightening loose bushings is self-evident. However, one precaution must be observed. *Avoid forcing the nuts or screws down too tight.* If excessive pressure is exerted on the bushings, damage or breakage is almost certain. If the threads on bushing stud bolts are found stripped so that they cannot be tightened, replace the entire bushing.

d. **CLEAN (C)**. Insulated bushings are easily cleaned. Never use abrasive materials, because the glazed finish will be destroyed, thus permitting moisture to be absorbed. A clean cloth is usually satisfactory. If deposits of grime or dirt on the surface of a bushing are hard to remove, use dry-cleaning solvent (SD). After the surface has been cleaned with a solvent, carefully polish it with a dry cloth. Otherwise, a thin film of the solvent will be left which may impair the effectiveness of the bushing as a high-voltage insulator.

26. Switches

a. **INSPECT (I)**. Inspect the mechanical action of each switch and, while so doing, look for signs of dirt or corrosion on all exposed elements. Examine the elements of the switch visually. Check the action of the switch by flipping the control knob or toggle, and note the freedom of movement and the amount of spring tension. There should be no searching for contact.

b. **CLEAN (C)**. Clean the exterior surfaces of switches with a stiff brush moistened with dry-cleaning solvent (SD).

27. Coils

a. **INSPECT (I)**. Inspect the tuning coil sets and the transformer coils for cleanliness of the ceramic coil form and secureness of mounting supports. Check all connections for proper contact.

b. **TIGHTEN (T)**. Tighten any loose coil mounting or connections by resoldering wires or tightening screws.

c. **CLEAN (C)**. Clean the coil form and the coil with a soft brush. Remember the coil form is actually performing the function of a high-voltage insulator. Therefore, the same preventive maintenance will apply to the coil as to high-voltage insulators and bushings.

28. Rheostats and Potentiometers

a. **INSPECT (I)**. (1) Inspect the mechanical condition of the controls (R-32 and R-33). The arm should be keyed tightly to the shaft, and the shaft should turn easily in the bushing which supports it.

(2) Inspect the assembly and mounting screws, setscrews, and nuts.

(3) Examine the insulating body of the controls for dust, dirt, cracks, and chipped places.

(4) Examine all metallic parts for dust, dirt, and corrosion.

b. **TIGHTEN (T)**. Tighten loose assembly or mounting screws.

c. **CLEAN (C)**. (1) Clean the exposed contact surfaces of the controls and the connections, whenever they are dirty or corroded.

(2) Remove grease and dirt from the control parts with carbon tetrachloride.

(3) If metal surfaces are corroded, clean them with crocus cloth.

(4) Clean the contact surface of the arm by inserting a strip of crocus cloth between the arm and the carbon block and drawing the cloth back and forth.

(5) Clean the body of the control with a brush or cloth.

29. Terminal Blocks

a. **INSPECT (I)**. (1) Inspect terminal blocks for cracks, breakage, dirt, loose connections, and loose mounting screws.

(2) Carefully examine connections for mechanical defects, dirt, and corrosion.

b. **TIGHTEN (T)**. Tighten loose screws, lugs, and mounting bolts. When tightening screws, be sure to select a screwdriver of correct size; do not exert too much pressure. Remove loose connectors and clean them if they are dirty or corroded.

c. **CLEAN (C)**. Clean terminal blocks, when they require it, with a dry brush. When necessary, use a cloth moistened with dry-cleaning solvent (SD). Thoroughly wipe the block with a clean cloth and then brush it to remove the lint.

30. Multiple Connectors

Multipile connectors and plugs are used to connect the receiver and power supply.

a. **INSPECT (I)**. Inspect the female ends of the connectors for corrosion and collected dust. Inspect the mountings for cracks and loose connections. Inspect the male ends for loose and broken pins and for proper contact in the plugs.

b. **CLEAN (C)**. Clean the male and female ends of the connectors with a brush moistened in carbon tetrachloride. Remove corrosion with No. 0000 sandpaper, then wipe with a clean cloth.

31. Cords and Cables

The cables in Radio Receiver R-140/FSM-1 (National HRO series of receivers), and power supplies are the life lines of the equipment. The conditions of the cabling must be closely observed.

a. **INSPECT (I)**. Inspect the cables for cracked or deteriorated insulation, frayed or cut insulation at the connecting and supporting points, and improper placement which places the cables or connections under strain. Also watch for kinks and improper supports.

b. **TIGHTEN (T)**. Tighten loose coupling rings and cable connections.

c. **CLEAN (C)**. Clean connections on cables when they are dirty or corroded. Clean cor-

roded connectors with No. 0000 sandpaper. Clean the entire surface of the connector. *No attempt should be made to remove individual prongs from cable plugs.*

32. S—Meter

This meter is an extremely delicate instrument and must be handled carefully. It requires very little maintenance. It is a precision instrument and ordinarily cannot be repaired in the field.

a. **INSPECT (I)**. Inspect the leads and connections of the meter. Look for loose, dirty, and corroded connections. Look for a cracked or broken cover glass. Since the movement of the meter is extremely delicate, its accuracy will be seriously affected if the glass is broken and dirt and water filter through.

b. **TIGHTEN (T)**. Tighten all connections found loose. All loose meter wires should be inspected for dirt or corrosion before they are tightened. The tightening of meter connections requires a special technique because careless handling can easily crack the meter case.

c. **CLEAN (C)**. The meter case can usually be cleaned with a dry cloth. If cleaning is difficult, dampen the cloth with dry-cleaning solvent (SD). Clean dirty connections with a small brush or piece of cloth dipped in dry-cleaning solvent (SD).

d. **ADJUST (A)**. Normally, the meter in the receivers should indicate zero when the equipment is turned off. Before deciding that the meter needs readjusting, tap the meter case *lightly* with the tip of one finger. This will help the needle to overcome the slight friction which sometimes exists at the bearings and prevents an otherwise normal unit from coming to rest at zero. If adjustment is needed, insert the tip of the thinnest screwdriver available into the slotted screw head located below the meter glass and *slowly* turn the adjusting screw until the pointer is at zero. Lightly tap the meter case again and view the meter face and pointer *full on*, and not from either side.

33. Pilot Lamp

The pilot lamp is used to indicate when power has been applied to the circuit. It is easily removed and replaced.

a. **INSPECT (I)**. Inspect the pilot lamp assembly for a loose lamp, loose mounting screws, and loose, dirty, or corroded connections.

b. **TIGHTEN (T)**. (1) Tighten loose mounting screws and resolder any loose connections.

(2) Screw the loose lamp tightly into its socket.

34. Jack and Plugs

The jack will require very little attention, and then only at infrequent intervals. Occasionally it will be necessary to tighten the mounting nut, clean the contacts, or increase the spring tension. Remove dirt with a brush and carbon tetrachloride. Remove corrosion with a piece of crocus cloth followed by a clean cloth. Increase spring tension, when necessary. Try the action of the jack after each adjustment. Be sure to keep all soldered connections intact. To clean dirty or corroded telephone-type plugs (PL-1), use paste metal polish. After cleaning, remove all traces of polish remaining with carbon tetrachloride. Finish off with a clean dry cloth.

35. Cabinets, Chassis, and Mountings

The cabinets which house the various components of the receivers and power supplies are constructed of sheet steel, coated with a black crackle finish.

a. **INSPECT (I)**. Inspect the outside and inside of each cabinet thoroughly, paying strict attention to every detail. Check the ventilator mountings, the panel screws, and the zero settings of the meter. Examine the pilot lamp covers for cracks and breaks. Inspect the panel for loose knobs, switches, and jacks.

b. **CLEAN (C)**. Clean each cabinet, outside and in, with a clean dry cloth. Use dry compressed air to blow out all accumulated dirt and dust. Repaint any surface found scratched, rusted, or chipped.

c. **TIGHTEN (T)**. Tighten all loose mounting bolts, panel screws, plugs, and control knobs.

36. Headset and Loudspeaker

These auxiliary items of equipment are essential to the operation of the radio set. The operator must therefore give them the same care as the radio itself.

a. **INSPECT (I)**. Inspect all external surfaces for dirt and corrosion. See that all cable con-

nections are tight and that plugs and jacks fit together properly.

b. **Clean (C)**. Clean all items of the equipment in accordance with instructions previously outlined for cords, jacks, cabinets, etc.

37. Coupling Shafts and Control Knobs

The control of various capacitors, switches, and resistors, is effected through coupling shafts that connect these items to control knobs located on the front panel. It is important that these shafts and control knobs be kept tight at all times.

38. Gears

a. **INSPECT (I)**. Check the antibacklash gears for proper operation by varying the panel tuning controls. (See fig. 24.)

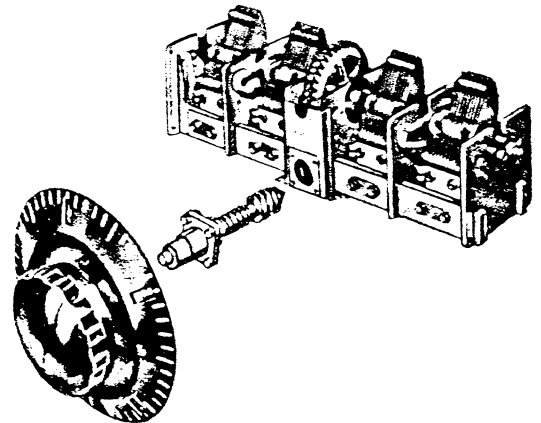

Figure 24. Main tuning gear and split spring loaded worm wheel.

Section VII. ITEMIZED PREVENTIVE MAINTENANCE

39. Introduction

For ease and efficiency of performance, preventive maintenance on Radio Set R-140/-FSM-1 (National HRO series of receivers) and power supplies will be broken down into operations that can be performed at different time intervals. In this section the preventive maintenance work to be performed on the radio set at the specified time intervals is broken down into units of work called items. The general techniques involved and the application of the

FITCAL operations in performing preventive maintenance on individual parts are discussed in paragraphs 20 through 38. These general instructions are not repeated in this section. When performing preventive maintenance, refer to paragraphs 20 through 38 if more information is required for the following items. All work is to be performed with the power removed from the equipment. After preventive maintenance has been performed on a given day, the equipment should be put into operation and checked for satisfactory performance. (See par. 19.)

40. Preventive Maintenance Tools and Materials

The following preventive maintenance tools will be needed:

- Common hand tools.
- Clean cloth.
- #0000 sandpaper.
- Crocus cloth.
- Fine file or relay burnishing tool.
- Dry-cleaning solvent (SD).
- Paste metal polish.
- Carbon tetrachloride.
- Small brush.

Note. Gasoline will not be used as a cleaning fluid for any purpose. Solvent, Dry-cleaning, is available as a cleaning fluid through established supply channels. Oil, Fuel, Diesel, may be used for cleaning purposes when dry-cleaning solvent (SD) is not at hand. Carbon tetrachloride will be used as a cleaning fluid only in the following cases: where inflammable solvents cannot be used because of the fire hazard, and for cleaning electrical contacts including plugs, switch points, tube socket contacts, and tube pins.

41. Item 1, Front of Operating Panel (fig. 23)

OPERATIONS:

- ITCA Control knobs.
- I Antenna and ground connections.
- ITC Pilot lamp.

42. Item 2, Top of Chassis (fig. 22)

OPERATIONS:

- ITC Tubes and sockets.
- IT Transformer shields.
- IT Tuning capacitor and gear assembly.
- IC Power cord and plug.
- IT Locknuts, mounting nuts, and screws.

43. Item 3, Bottom of Chassis (fig. 39)

OPERATIONS:

- ITC Chassis.
- ITC Capacitors.
- ITC Resistors.
- ITC Chokes.
- ITC Coil.
- ITC Antenna terminal insulator.
- ITC Terminal boards.

44. Item 4, Power Supplies

OPERATIONS:

- ITC Fuse container.
- I Power switch.
- I Voltage switch.
- IT Screws or bushings.
- ITC Tube and tube contacts.

45. Preventive Maintenance Check List

The following check list is a summary of the preventive maintenance operations to be performed on Radio Receiver R-140/FSM-1 or National HRO receivers and their power supplies. The time intervals shown on the check list may be reduced at any time by the local commander. For best performance of the equipment, perform operations at least as frequently as called for in the check list. The echelon column indicates which operations are first echelon maintenance. Operations are indicated by the letters of the word FITCAL. For example, if the letters ITCA appear in the operations column, the item to be treated must be inspected (I), tightened (T), cleaned (C), and adjusted (A).

Item No.	Operations	Item	When performed			Echelon
			Before operation	Daily	Weekly	
1	ITCA	Front of operating panel	x	x		1
2	ITC	Top of chassis	x		x	1
3	ITC	Bottom of chassis	x		x	1
4	ITC	Power supplies	x		x	1

F	I	T	C	A	L
Feel	Inspect	Tighten	Clean	Adjust	Lubricate ¹

¹ The Lubricate operation does not apply to this equipment.

Section VIII. LUBRICATION

Note. On manufacturer's recommendation, additional lubrication is not required or needed on this receiver or its power supply. All lubricated parts, such as the main tuning dial drive, are supplied with sufficient lubricant to last the lifetime of the equipment.

Section IX. MOISTUREPROOFING AND FUNGIPOOFING

46. General

When operated in tropical areas where temperature and relative humidity are extremely high, Signal Corps equipment requires special attention. These are some of the problems met:

a. Resistors, capacitors, coils, chokes, transformer windings, etc., fail because of the effects of fungus growth and excessive moisture.

b. Electrolytic action, often visible in the form of corrosion, takes place in resistors, coils, chokes, transformer windings, etc., causing eventual break-down.

c. Hook-up wire insulation and cable insulation break down. Fungus growth accelerates deterioration.

d. Moisture forms electrical leakage paths on terminal boards and insulating strips, causing flash-overs.

47. Treatment

A moistureproofing and fungiproofing treatment has been devised which, if properly applied provides a reasonable degree of protection against fungus growth, insects, corrosion, salt spray, and moisture. The treatment involves the use of a moisture and fungi-resistant varnish applied with a spray gun or brush. Refer to TB SIG 13 for a detailed description of the varnish-spray method of moistureproofing and fungiproofing and the supplies and equipment required in this treatment.

Caution: Varnish spray may have poisonous effects if inhaled. To avoid inhaling spray, use respirator if available; otherwise, fasten cheesecloth or other cloth material over nose and mouth. Never spray varnish or lacquer near an open flame. Do not smoke in a room where varnish or lacquer is being sprayed. The spray may be highly explosive.

48. Moistureproofing and Fungiproofing I-F Transformers of Receiver

a. PREPARATION. Make all repairs and adjustments necessary for proper operation of the receiver.

b. DISASSEMBLY. (1) Dismount unit from rack.

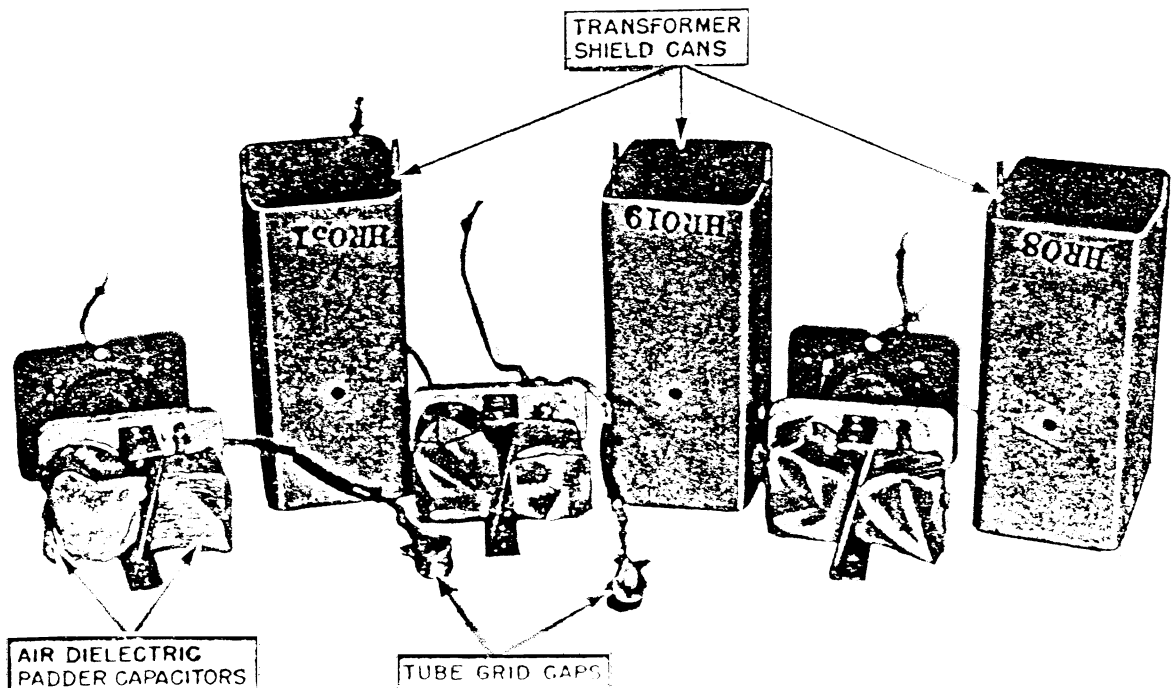

Figure 25. Masking of intermediate transformers of the receiver.

(2) Remove receiver from case.

(3) On the underside of the chassis, unsolder the leads of the three i-f transformers.

(4) Remove mounting nuts and lift the shield cans from the chassis.

(5) Unscrew the four cap screws located on the sides of transformer shields and lift out transformer assembly.

c. CLEANING. Clean all dirt, dust, rust, and fungus from the equipment to be processed. Clean all oil and grease from the surface to be varnished.

d. MASKING (fig. 25). Cover the air dielectric padder capacitors and tube grid caps with masking tape.

e. DRYING. Place equipment in an oven or under heat lamps and dry for 3 hours at 160°F.

f. VARNISHING. (1) Apply three coats of moistureproofing and fungiproofing varnish (Lacquer, Fungus-resistant, stock No. 6G10-05.3, or equal). Allow each coat to dry for 15

or 20 minutes at temperature specified in paragraph *e* above before applying the next coat.

(2) Apply varnish immediately after the equipment is dried. If varnish is not applied immediately, moisture condenses on the equipment. Varnish applied over the moisture peels off readily after the varnish has dried.

(3) All varnishing must be done with a brush, as spraying will cause the polystyrene coil forms to become pitted.

g. REASSEMBLY. (1) Remove all masking tape, being careful not to peel varnish from nearby areas.

(2) Replace transformer assemblies in shields and remount shields on chassis.

(3) Resolder transformer leads on underside of chassis.

(4) Check the receiver operation and peak the i-f transformers to insure that they are operating normally. Make necessary repairs if transformers do not function properly.

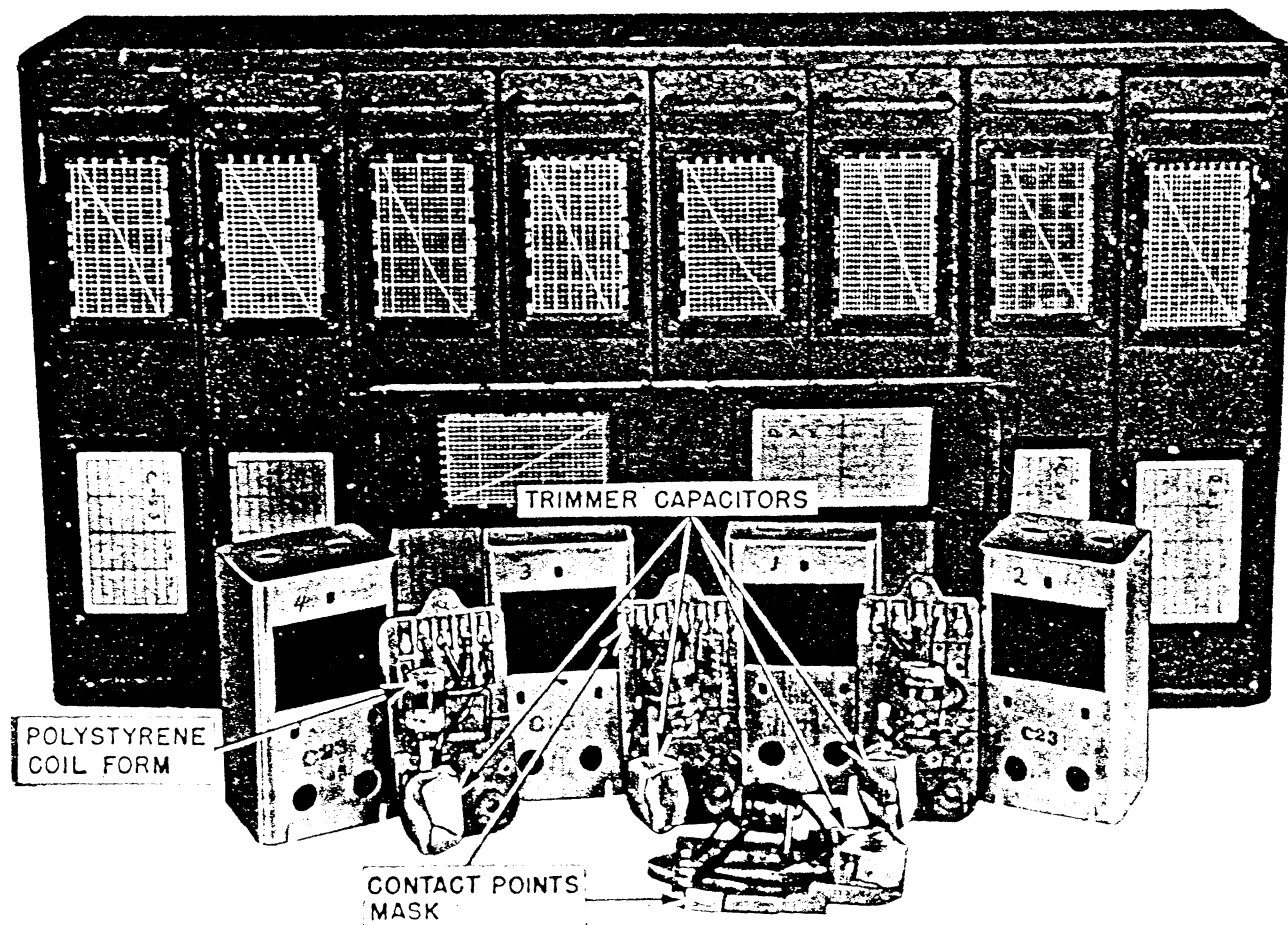

Figure 26. Masking of plug-in coils of the receiver.

49. Moistureproofing and Fungiproofing Plug-In Coils of Receiver

a. PREPARATION. See paragraph 48a.

b. DISASSEMBLY. Remove the coil shields from the nine sets of plug-in coils by loosening the screws on the back edge of the plates.

c. CLEANING. See paragraph 48c.

d. MASKING (fig. 26). (1) Cover the trimmer capacitors with masking tape.

(2) Cover the contact points with masking tape.

e. DRYING. See paragraph 48e.

f. VARNISHING. See paragraph 48f.

g. REASSEMBLY. See paragraph 48g.

50. Moistureproofing and Fungiproofing Chassis of Receiver

a. PREPARATION. See paragraph 48a.

b. DISASSEMBLY. Remove plug-in coils from receiver.

c. CLEANING. See paragraph 48c.

d. MASKING (fig. 27). (1) Cover contact points for plug-in coils in receiver with masking tape.

(2) Cover the face of meter with masking tape.

(3) Cover phone jack on the front panel with masking tape.

(4) Remove tube shields and cover tube grid caps with masking tape.

(5) Cover all holes in i-f transformers and crystal filter shields with masking tape.

(6) Cover contact leaves of phone jack mounted on the back of front panel with masking tape.

(7) Cover ground and antenna binding posts with masking tape.

(8) Mold paper around the variable c-w capacitor on the bottom of the chassis. Fasten the paper with masking tape.

(9) Mold paper around the tuning capacitors and fasten with masking tape.

(10) Cover zero adjusting potentiometer of S-meter with masking tape.

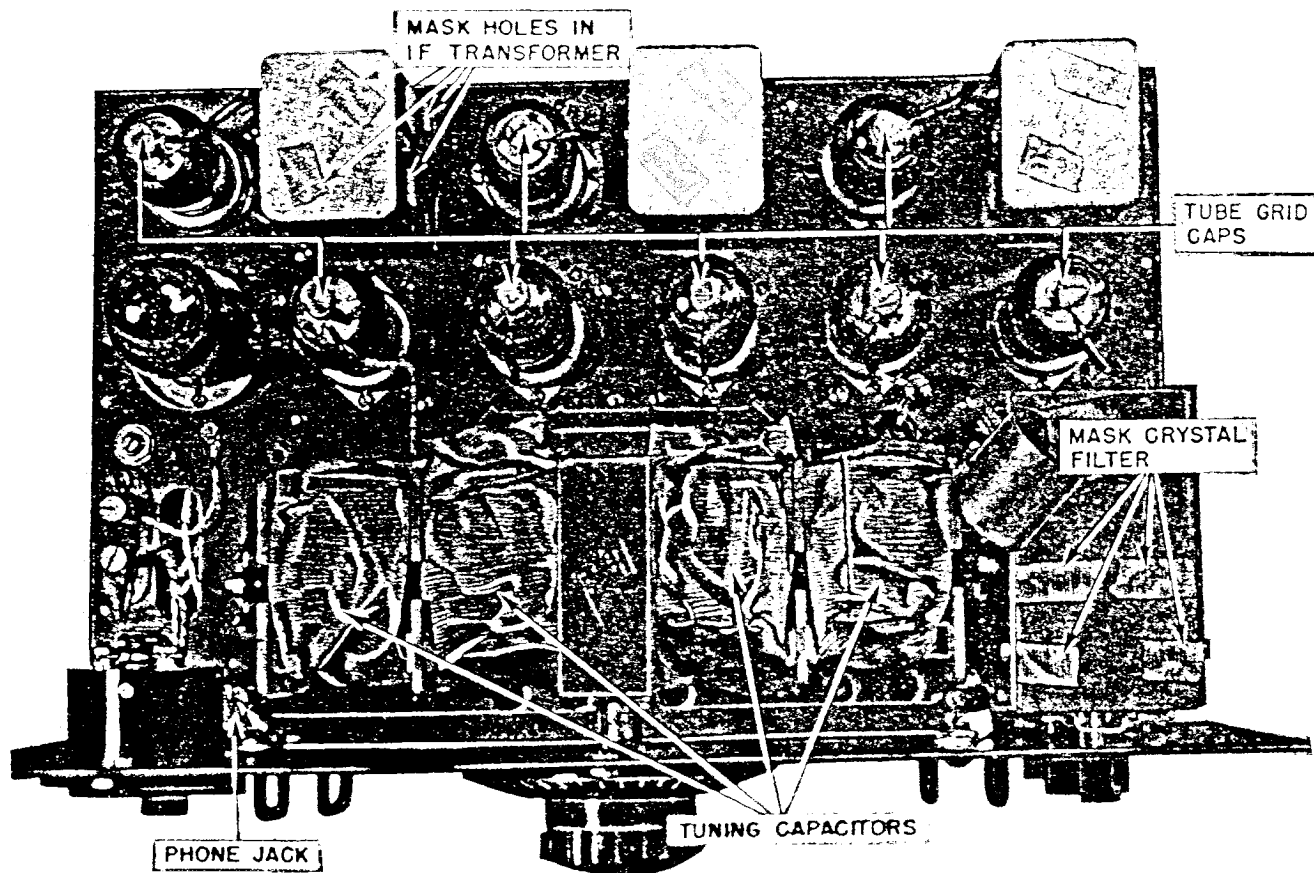

Figure 27. Masking of chassis of Radio Receiver R-140/FSM-1.

(11) Cover the phone tip jacks and binding posts on the back of the chassis with masking tape.

(12) Remove all tubes and cover their sockets with masking tape. If they are to be left in the set, be sure the tube prongs are kept free of varnish.

e. DRYING. (See par. 48e.)

f. VARNISHING. (See par. 48f.)

g. REASSEMBLY. (See par. 48g.)

h. MARKING. Mark the letters MFP and the date of treatment to the left of the nameplate on the front panel of the receiver.

Example: MFP—5 Jan 45.

Note. Be sure to check the performance of the receiver upon the completion of moistureproofing and fungiproofing. Recheck the receiver two weeks after the treatment, as ageing of the varnish may cause some variation in alignment.

51. Moistureproofing and Fungiproofing Rectifier Power Unit, Navy Type No. 20090

a. PREPARATION. Make all repairs and adjustments necessary for proper operation of the equipment.

b. DISASSEMBLY. (1) Dismount rectifier from rack.

(2) Remove rectifier from its case.

c. CLEANING. Clean all dirt, dust, rust, and fungus from the equipment to be processed. Clean all oil and grease from the surfaces to be varnished.

d. MASKING. (1) Remove female plug of power cord from male receptacle on back of chassis. Cover receptacle with masking tape.

(2) Cover four-prong socket on back of chassis with masking tape.

e. DRYING. Place equipment in an oven or under heat lamps and dry for 3 hours at 160° F.

Caution: do not exceed 160° F. If the wax begins to melt in any of the components, decrease the temperature and increase the baking time approximately 1 hour for each decrease of 10° F in temperature.

f. VARNISHING. (1) Apply three coats of moistureproofing and fungiproofing varnish (Lacquer, Fungus-resistant, stock No. 6G10-05.3, or equal). Allow each coat to dry for 15 or 20 minutes at temperature specified in *e* above before applying the next coat.

(2) Apply varnish immediately after the equipment is dried. If varnish is not applied immediately, moisture condenses on the equipment. Varnish applied over the moisture peels off readily after the varnish has dried.

(3) Spray all unmasked circuit elements. Brush-coat all surfaces not reached by the spray.

g. REASSEMBLY. (1) Remove all masking tape, being careful not to peel varnish from nearby areas.

(2) Touch up by brush any of the sprayed areas that show a break in the continuous film of varnish.

(3) Clean electrical contacts with carbon tetrachloride.

(4) Reassemble the equipment and test its operation.

(5) Remount the equipment in rack.

h. MARKING. Mark the letters MFP and the date of treatment above the grill on the front panel of the rectifier.

Example: MFP—10 Nov 45.

52. Moistureproofing and Fungiproofing Power Supply SPU-686-S

a. PREPARATION. See paragraph 51a.

b. DISASSEMBLY. (1) Dismount unit from rack and remove chassis from case.

(2) As equipment is disassembled, immediately replace all screws, bolts, and nuts in their respective holes to prevent loss or clogging of threads during treatment.

(3) Disconnect and remove vibrapack from chassis.

(4) Remove cover from vibrapack so that all wiring and components are exposed.

(5) Tighten all terminal screws where wiring is disconnected.

(6) Remove the vibrator unit and rectifier tube 6X5 from the vibrapack.

c. CLEANING. See paragraph 51c.

d. MASKING. (1) Mask the lugs of all wiring disconnected in paragraph 52b.

(2) Mask the sockets from which the vibrator unit and rectifier tube 6X5 were removed.

(3) Mask the 4-prong outlet socket on the main chassis.

(4) Cover the lugs on the two battery terminals with masking tape.

e. DRYING. See paragraph 51e.

f. VARNISHING. See paragraph 51f.

g. REASSEMBLY. See paragraph 51g.

h. MARKING. See paragraph 51h.

53. Moistureproofing and Fungiproofing Power Supply 686

The instructions for moistureproofing and fungiproofing Power Supply SPU-686-S are applicable to Power Supply 686. (See par. 52.)

54. Moistureproofing and Fungiproofing Power Supply 697

a. PREPARATION. (1) Make all repairs and adjustments necessary for proper operation of equipment.

(2) Give the unit a maintenance check to insure proper operation.

b. DISASSEMBLY. (1) Remove set from case.

(2) Remove tube from socket.

c. CLEANING. See paragraph 51c.

d. MASKING. (1) Cover tube socket on both sides with masking tape.

(2) Cover power output socket on both sides with masking tape.

e. DRYING. See paragraph 51e.

f. VARNISHING. See paragraph 51f.

g. REASSEMBLY. See paragraph 51g.

h. MARKING. Mark the letters MFP and the date of treatment near the equipment nameplate and in such a location that the marking will not become obliterated or rubbed off.

Example: MFP—9 Dec 45.

PART FOUR
AUXILIARY EQUIPMENT

(Not used.)

PART FIVE

REPAIR INSTRUCTIONS

Note. Failure or unsatisfactory performance of equipment used by the Army Ground Forces and the technical services will be reported on WD, AGO Form

468 (Unsatisfactory Equipment Report); by Army Air Forces on Army Air Forces Form 54 (Unsatisfactory Report).

Section X. THEORY OF EQUIPMENT

55. Simplified Block Diagram

The HRO-M and HRO-5 series receivers are conventional superheterodyne receivers. The

basic circuit is shown in the simplified block diagram, figure 28. The crystal filter circuit and the a-v-c circuit are the only complex parts of the equipment and they are explained in the step-by-step analysis, paragraph 56.

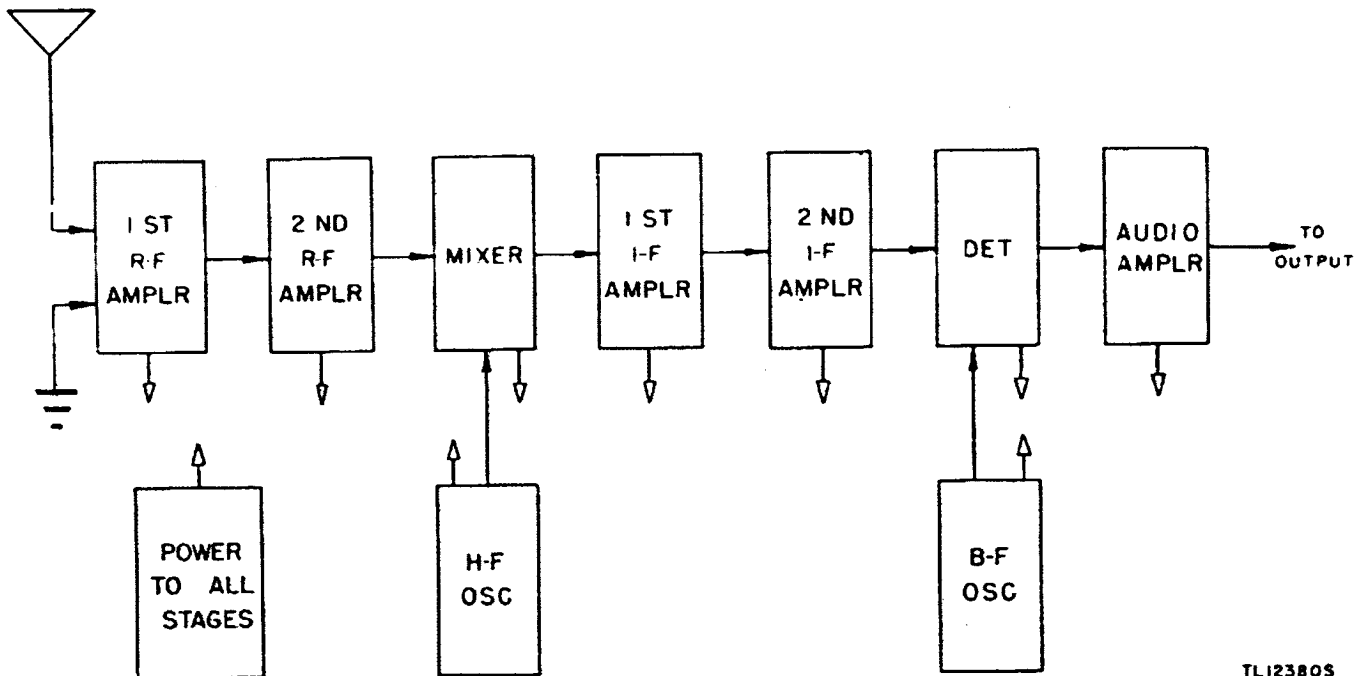

TL123805

Figure 28. Radio Receiver R-140/FSM-1 (National HRO series of Receivers)—simplified block diagram.

56. Condensed Theory of Receiver Operation

Radio Receiver R-140/FSM-1 (National HRO series of receivers) is a conventional superheterodyne communications receiver designed for the reception of c-w, m-c-w, and voice signals. The circuit is of standard design and uses two r-f stages, a high-frequency oscillator (h-f), a mixer, two i-f stages, a combined detector and low power audio frequency (a-f) output stage for use with headphones, and an additional a-f output stage which supplies sufficient power to operate a loudspeaker. The last audio output stage is cut out of the circuit when the phone jack is in use. The circuit is

also equipped with an S-meter to indicate the relative strength of the input signal, and a crystal filter to adjust selectivity and to suppress interfering signals. The receiver may be operated with or without the automatic volume control.

a. R-F STAGES V-1 AND V-2. The two r-f stages are similar in design and function. The input signal is applied to an r-f transformer, tuned by a section of the main tuning capacitor, C-46-A (first r-f), or C-46-B (second r-f). The secondary of this transformer is coupled directly to the control grid of the r-f amplifier tubes, V-1 or V-2. Minimum bias is furnished

by cathode resistors R-27 or R-29. The plate of the first r-f amplifier, V-1, is connected directly to the primary coil of the second r-f

transformer. The output of the second r-f stage is directly coupled to the primary coil of the mixer transformer assembly. (See fig. 29.)

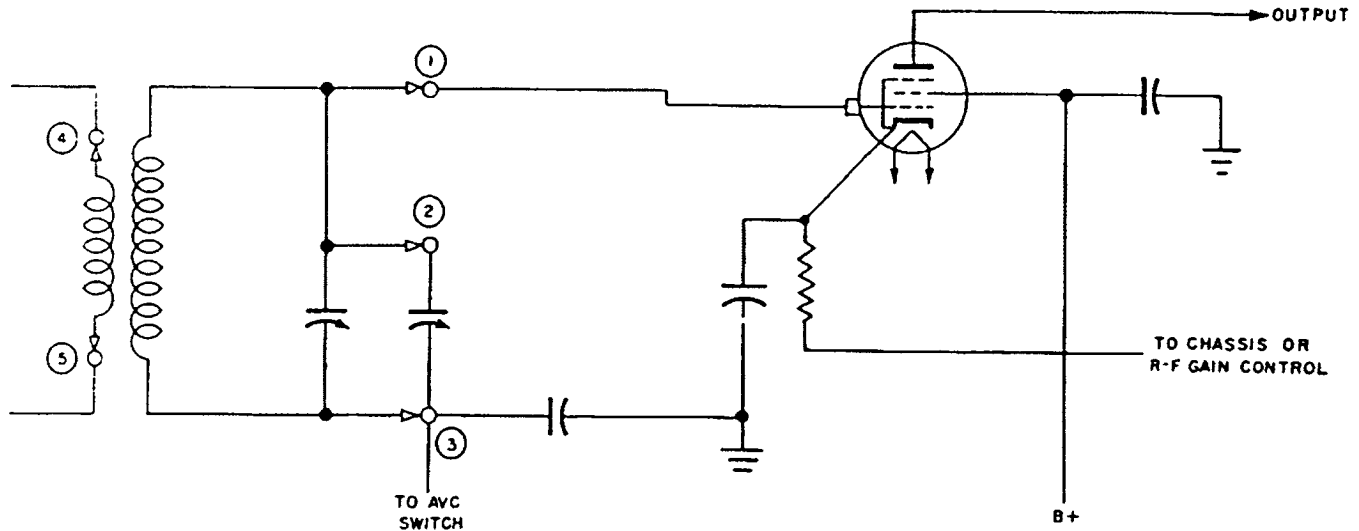

○ = CONTACT POINTS ON BRUSH BOARD

Figure 29. Partial schematic diagram of typical r-f stage.

TL123815

b. MIXER STAGE V-3. This stage is similar to the basic r-f stages and is tuned by section C-46-C of the main tuning capacitor. The r-f signal applied to the control grid of mixer V-3 heterodynes with the h-f oscillator potential applied to the screen grid, and since V-3 is biased to operate on the nonlinear portion of its grid voltage-plate current characteristic, a third r-f potential is produced in the output circuit of V-3. This third signal is the difference between the input signal and the oscillator frequency and is known as the intermediate frequency (i.f.) of the receiver. The intermediate frequency is approximately 456 kc (due to crystal frequency tolerance).

c. HIGH-FREQUENCY OSCILLATOR V-4. This is an electron-coupled, modified Hartley type oscillator stage and is tuned by section C-46-D of the main tuning capacitor, with C-38 in series as a padder. This padder is used to modify the tuning of the h-f oscillator circuit so that it will maintain a fixed frequency difference of 456 kilocycles higher than the signal frequency circuits when the main tuning capacitor section C-46-D is varied from minimum to maximum capacitance. H-f oscillator potential obtained from the cathode of V-4 is coupled to the screen grid of the mixer by means of capacitor C-7.

d. INTERMEDIATE FREQUENCY AMPLIFIERS V-5 AND V-6 AND THE CRYSTAL FILTER. (1) *First I-f Stage.* The i-f potential from the mixer, V-3, is coupled to the first i-f amplifier, V-5, by the first i-f transformer, T-1, which incorporates the crystal filter assembly. The amplifier tube, V5, output is coupled directly to the tuned primary of second i-f transformer, T-2. Minimum bias for V-5 is supplied by cathode resistor R-4.

(a) *Crystal filter bridge circuit* (fig. 30). The crystal filter bridge circuit coil is closely coupled to the primary, L-66, while coupling to L-68 is capacitive. As shown in figure 30, the four arms of the bridge are capacitors C-31, C-32, C-53, and the crystal holder capacitance. Selectivity is greatly increased by use of the crystal because of its high rate of reactance change for frequencies removed from the crystal frequency. When the input circuit is detuned by means of the selectivity control C-52, its effective resistance decreases and damping of the crystal is reduced, resulting in maximum selectivity and vice versa. The signal from the crystal bridge circuit is fed to tuned output coil L-68 of T-1 by means of capacitor C-54.

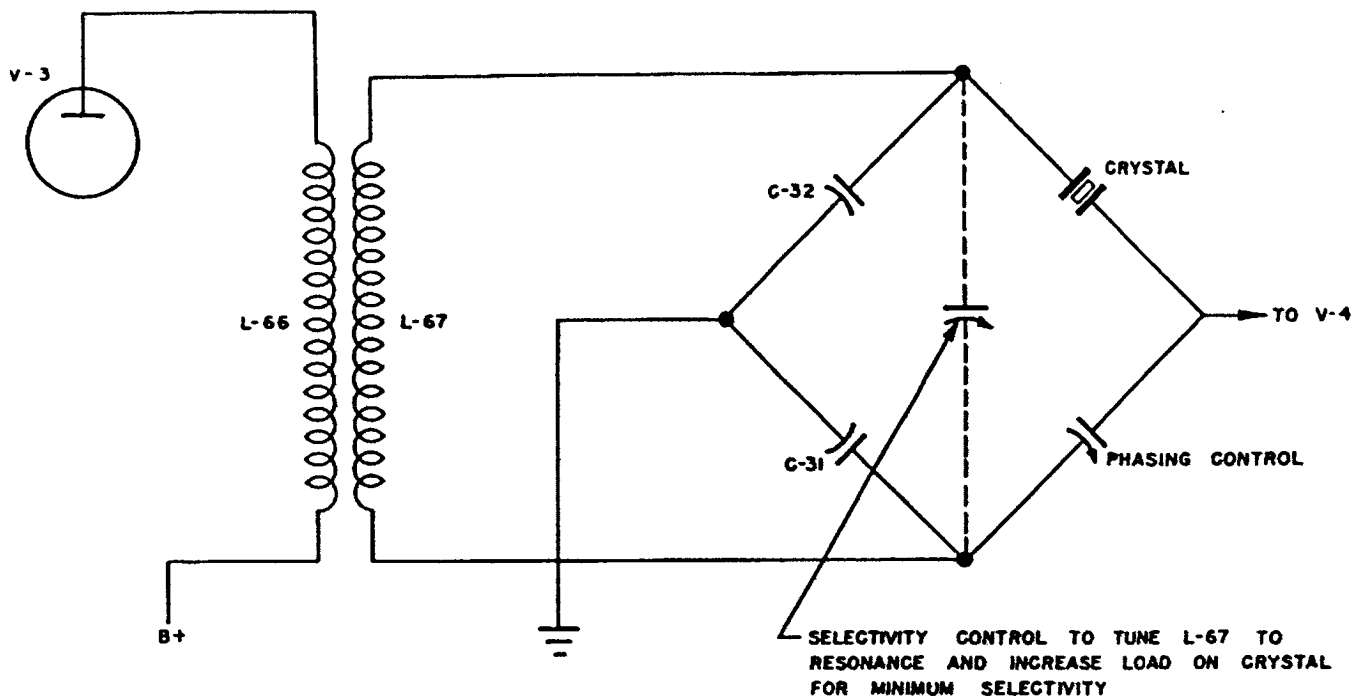

TL123825

Figure 30. Simplified schematic diagram of the crystal filter bridge circuit.

(b) *I-f Transformer T-1.* The mixer output is coupled directly to primary coil L-66 of T-1, and is applied to the crystal filter assembly by means of filter coil L-67. The output of L-68 is fed directly to the control grid of first i-f amplifier tube V-5. L-68 is tuned by varying the setting of trimmer capacitor C-55.

(2) *Second I-f stage.* The signal from first i-f amplifier V-5 is coupled to second i-f amplifier V-6 by the second i-f transformer, T-2. The plate of V-5 is connected to tuned primary coil L-69 of T-2, and tuned secondary coil L-70 is connected directly to the control grid of V-6. L-69 and L-70 are tuned by trimmer capacitors C-56 and C-57 respectively. The output of V-6 is connected to tuned primary coil L-71 of T-3. Minimum bias for V-6 is furnished by cathode resistor R-9.

e. **COMBINED DETECTOR AUTOMATIC VOLUME CONTROL AND FIRST AUDIO STAGE** (1) Tube V-7, used in this stage has two diode plates and a triode section, operated from a common cathode. The diode section functions as the automatic volume control and detector. The triode section is the first audio amplifier stage. The upper diode plate and the tuned secondary coil of T-3 form the signal rectifier circuit. The audio voltage which appears across audio load resistor R-12 is coupled by means of

capacitor C-14 to the high side of the AUDIO GAIN control R-33. R-13 and capacitors C-12 and C-13 comprise an r-f filter which prevents r-f voltage from entering the audio circuits. The output of the triode section of V-7 is coupled by means of R-18 and capacitor C-18 to control grid of V-9, the audio output stage.

(2) The a-v-c circuit is of conventional diode type. It utilizes the rectified voltage developed across load resistance R-12 in the V-7 diode section circuit. The a-v-c voltage is taken from the junction of R-12 and R-13 and is fed through filter resistor R-19 to the ON side of the A.V.C. switch. When the A.V.C. switch is in the ON position, the negative a-v-c bias voltage is applied to the grids of V-6, V-5, V-2 and V-1, in addition to the normal bias furnished by the cathode resistors. The diagram in figure 31 shows the a-v-c circuit during a no-signal condition with the A.V.C. switch in the ON position. The remaining diode and R-14 are connected to simulate a-v-c diode contact potentials with the A.V.C. switch OFF. When the circuit is functioning properly the S-meter should not vary more than two divisions with the A.V.C. switch in either position.

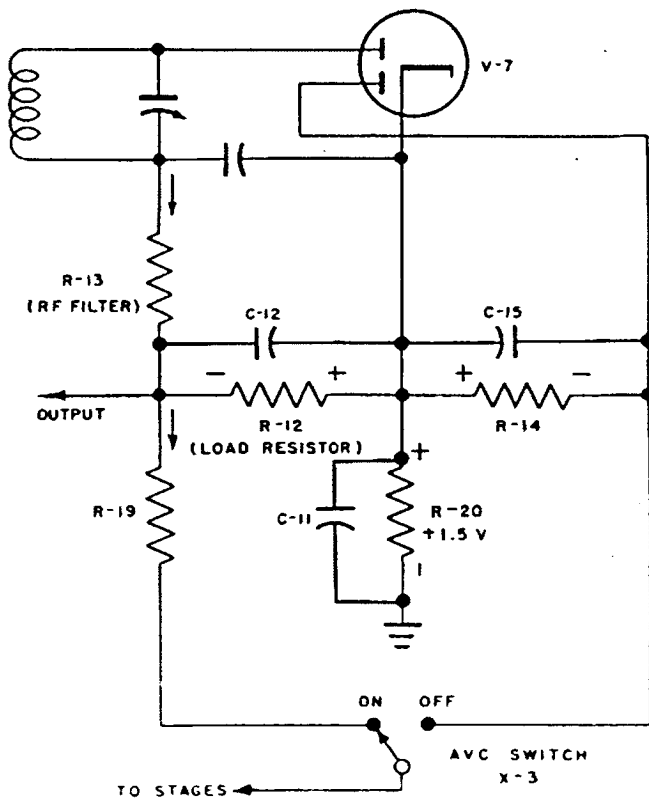

R-12 AND R-14 DEVELOP NORMAL DIODE CONTACT POTENTIAL
TL123835

Figure 31. Partial schematic diagram of the a-v-c circuit during no-signal condition.

f. C-W OSCILLATOR. This circuit is electron-coupled, and normally operates at 456 kc to provide an r-f potential with which an unmodulated i-f signal at the detector can heterodyne to produce an audible c-w beat note. The oscillator frequency is determined by transformer T-4. Capacitors C-62 and C-63, in parallel, provide adequate capacity to render the frequency of the c-w oscillator stable. The circuit frequency is adjustable within narrow limits by the C.W. OSC. control, C-27. To simplify shielding and to allow the use of a comparatively large variable capacitor to provide a small tuning change, this capacitor is connected between the cathode tap and the low potential end of L-73. Zero beat with the intermediate frequency should occur when the C.W. OSC. control is set at 9 to 9.5. C-w oscillator potential from the plate of V-8 is coupled to the upper diode of V-7 by means of C-33.

g. AUDIO OUTPUT STAGE. Audio output tube V-9 supplies power for a loudspeaker only. The

speaker terminals are connected directly in the plate circuit, while the headphone jack is coupled to the plate circuit of V-7. When headphones are used, the jack acts as a switch that disconnects V-9 by shorting the control grid to ground and connects the jack into the plate circuit of V-7 for lower output.

Section XI. TROUBLE SHOOTING

57. General Trouble-Shooting Information

No matter how well equipment is designed and manufactured, faults occur in service. When troubles do occur, the repairman must locate and repair them as rapidly as possible. This section contains information to aid personnel engaged in trouble shooting.

a. TROUBLE-SHOOTING DATA. Take advantage of the material supplied in this manual to help in the rapid location of faults. Consult the following trouble-shooting data when necessary:

(1) Block diagram of Radio Receiver R-140/FSM-1. (See fig. 28.)

(2) Complete schematic diagrams. (See figs. 36, 37, 42, and 43.)

(3) Simplified and partial schematic diagrams. These diagrams are particularly useful in trouble shooting, since in them the repairman can follow the electrical functioning of the circuits more easily than on the regular schematics.

(4) Voltage and resistance data for all tube sockets.

(5) Pin connections on sockets, plugs, and receptacles are numbered or lettered in the various diagrams.

(a) Seen from the bottom, pin connections are numbered in a clockwise direction around the sockets. On octal sockets the first pin clockwise from the keyway is the No. 1 pin.

(b) Plugs and receptacles are numbered on the side to which the associated connector is attached. To avoid confusion, some pins are identified by letters which appear directly on the connector.

b. TROUBLE-SHOOTING STEPS. The first step in servicing a defective receiver is to sectionalize the fault. Sectionalizing means tracing the fault to the component or circuit responsible for the abnormal operation of the set. The

second step is to localize the fault. Localization means tracing the fault to the defective part responsible for the abnormal condition. Some faults, such as burned-out resistors, r-f arcing, and shorted transformers can be located by sight, smell, and hearing. The majority of defects, however, must be located by checking voltage and resistance.

c. LOCALIZATION. Paragraphs 59 to 62 describe the method of localizing faults within the individual components. These paragraphs are accompanied by trouble-shooting charts which list abnormal symptoms and their probable causes. The charts also give the procedure for determining which of the probable locations of the fault is the exact one. In addition, there are a number of drawings which show the resistance and voltage values at every socket pin connection.

d. VOLTAGE MEASUREMENTS. Voltage measurements are an almost indispensable aid to the repairman, since most troubles either result from abnormal voltages or produce abnormal voltages. Voltage measurements are easily taken, since they can always be made between

two points in a circuit without interrupting the circuit.

(1) Unless otherwise specified, the voltages listed on the voltage charts are measured between the indicated points and ground.

(2) Always begin by setting the voltmeter on the highest range, so that the voltmeter will not be overloaded. If it is necessary to obtain increased accuracy, set the voltmeter to a lower range.

(3) When checking cathode voltage, remember that a reading can be obtained even when the cathode resistor is open. The resistance of the meter may act as a cathode resistor; thus, the cathode voltage may be approximately normal only as long as the voltmeter is connected between cathode and ground. Before the cathode voltage is measured, make a resistance check to determine whether the cathode resistor is normal.

e. PRECAUTIONS AGAINST HIGH VOLTAGE. Certain precautions must be followed when measuring voltages above a few hundred volts. High voltages are dangerous and can be fatal.

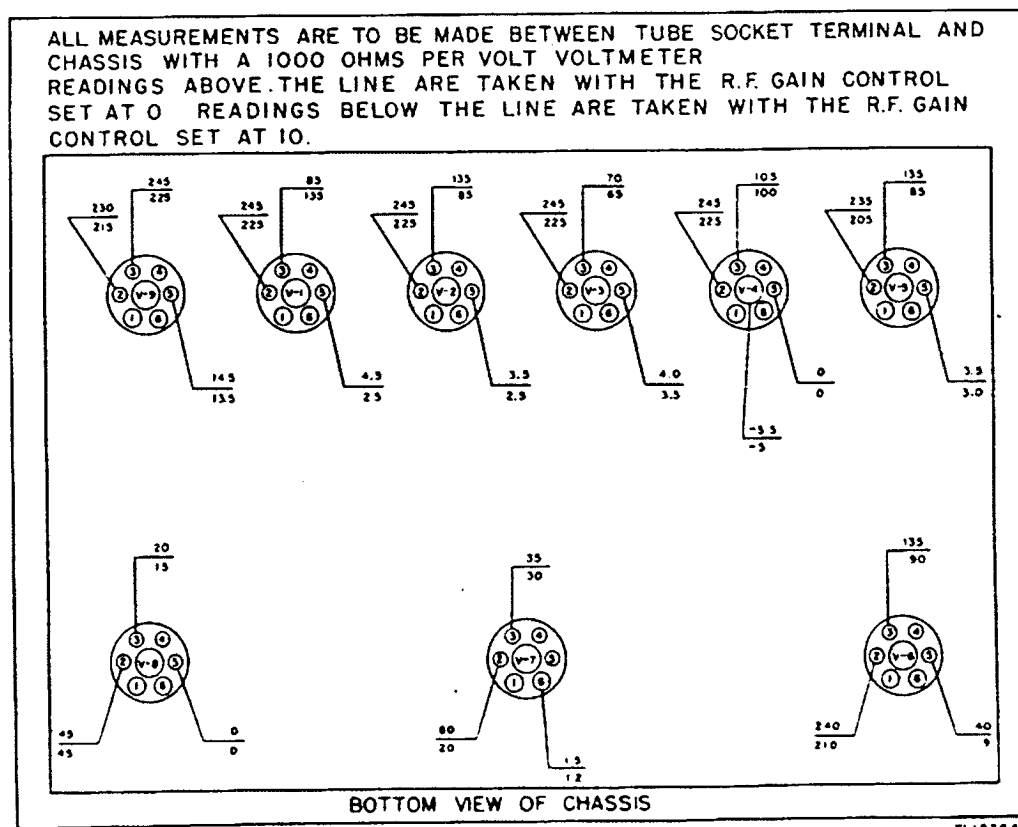

Figure 32. Radio Receiver R-140/F5M-1 (with glass tubes), and National HRO-M type receivers—tube socket voltage diagram.

When it is necessary to measure high voltages, observe the following rules.

(1) Connect the ground lead to the voltmeter.

(2) Place one hand in your pocket. This will eliminate the possibility of making accidental contact with either ground or another part of the circuit and causing the current to travel through the body, from one hand to the other.

(3) If the potential is less than 300 volts, connect the test lead to the hot terminal (which may be either positive or negative in respect to ground).

(4) If the potential is greater than 300 volts, shut off the power, connect the hot lead, step

away from the voltmeter, turn on the power, and note the reading on the voltmeter. Do not touch any part of the voltmeter, particularly when it is necessary to measure the voltage of two points which are above ground potential.

f. VOLTMETER LOADING. It is essential that the voltmeter resistance be at least 10 times as high as the resistance of the circuit across which the voltage is measured. If the voltmeter resistance is comparable to the circuit resistance, the voltmeter will indicate a lower voltage than the actual voltage present when the voltmeter is removed from the circuit.

(1) The resistance of the voltmeter in any range can always be calculated by the follow-

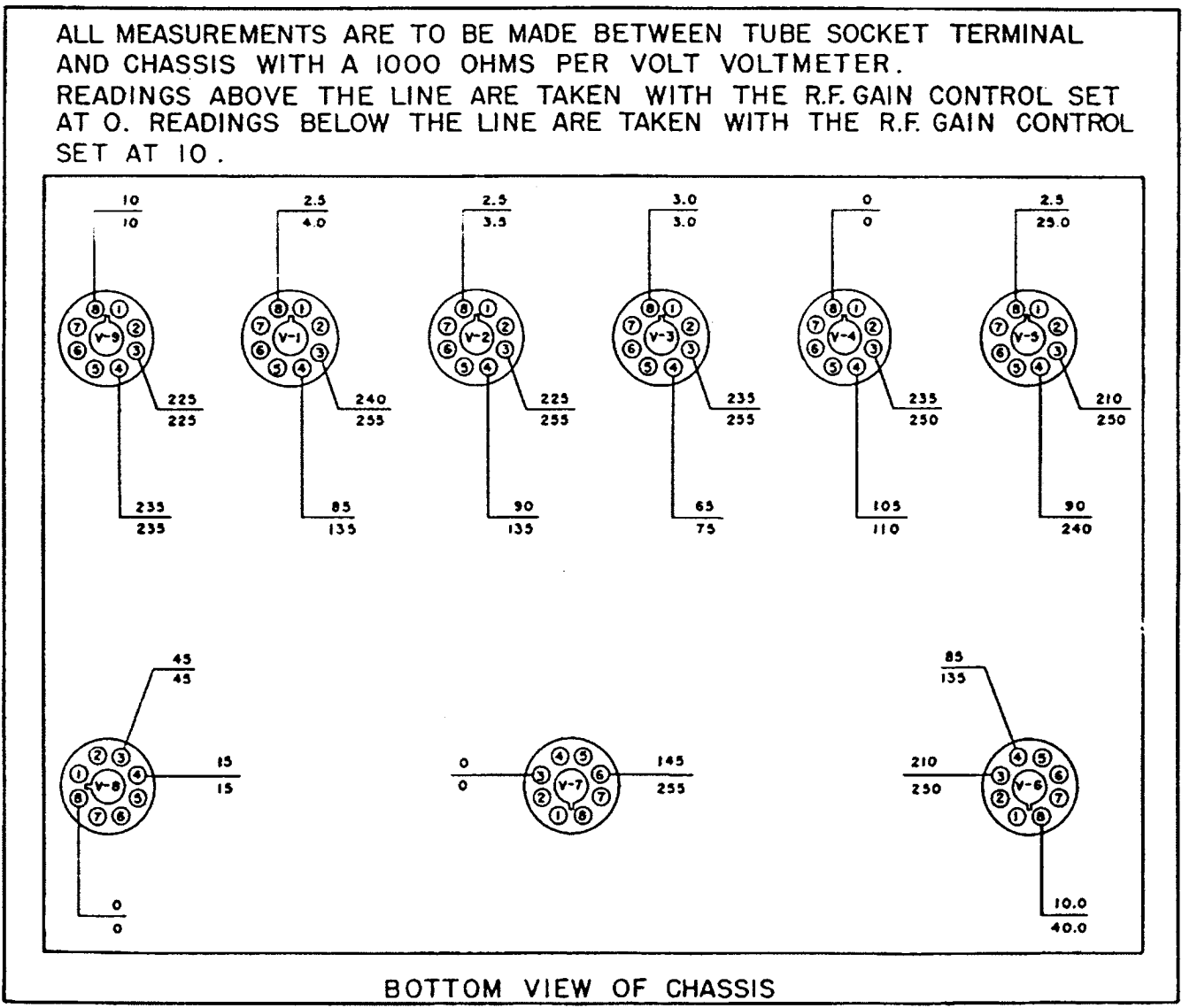

TL123855

Figure 33. Radio Receiver R-110/FSM-1 (with metal tubes), and National HRO-5 type receiver—tube socket voltage diagram.

ing simple rule: Resistance of the voltmeter equals the ohms per volt multiplied by the full-scale range in volts. For example: The resistance of a 1,000-ohms-per-volt meter on the 300-volt range is 300,000 ohms ($R = 1,000$ ohms per volt times 300 volts = 300,000 ohms).

(2) To minimize the voltmeter loading in high-resistance circuits, use the highest voltmeter range. Although only a small deflection will be obtained (possibly only 5 divisions in a 100-division scale), the accuracy of the voltage measurement will be increased. The decreased loading of the voltmeter will more than compensate for the inaccuracy which results from reading only a small deflection on the scale of the voltmeter.

(3) When a voltmeter is loading a circuit, the effect can always be noted by comparing the voltage reading on two successive ranges. If the voltage readings on the two ranges do not agree, voltmeter loading is excessive. The

reading (not the deflection) on the highest range will be greater than that of the lowest range. If the voltmeter is loading the circuit heavily, the deflection of the pointer will remain nearly the same when the voltmeter is shifted from one range to the other.

(4) The ohms-per-volt sensitivity of the voltmeter used to obtain the readings recorded on the voltage and resistance charts in this manual is printed on each chart. Use a meter having the same ohms-per-volt sensitivity, otherwise it will be necessary to consider the effect of loading.

58. Trouble Location Chart

The following table is supplied as an aid in locating trouble in Radio Receiver R-140/FSM-1 and associated power supplies. This table covers a number of common troubles that may develop while the equipment is in use, and applies also to the other models of National HRO receivers.

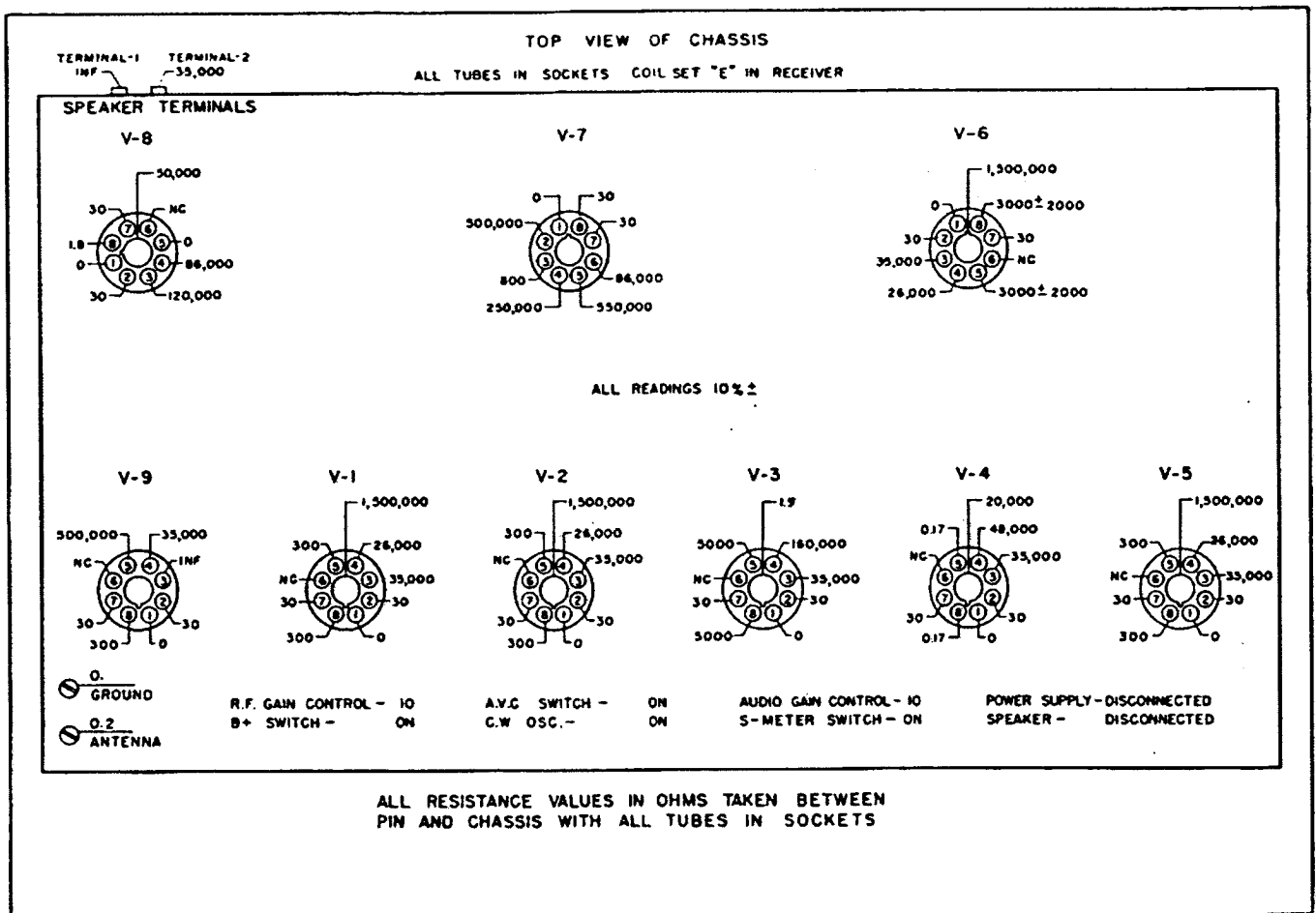

Figure 34. Radio Receiver R-140/FSM-1 (with metal tubes), and National HRO-5 type receivers, point-to-chassis resistance values.

TL123865

59. Sectionalizing Trouble in Radio Receiver R-140/FSM-1 (National HRO Series of Receivers) and Power Supplies

Symptoms	Probable trouble	Corrections
<p>1. Weak or no signal</p> <p style="text-align: center;">Direct B+ or filament short</p> <p>2. Noisy reception</p>	<p>1. Defective or burned out tube</p> <p>Antenna broken, open or shorted ..</p> <p>Incorrect antenna connection</p> <p>Headphones not properly plugged in</p> <p>Low socket voltages</p> <p>Low power supply voltage</p> <p>Shorted capacitors or resistors ...</p> <p>Leakage due to dust or humidity.</p> <p>Controls improperly set</p> <p>Coil not making good contact with brush board</p> <p>Damaged r-f coil or wiring</p> <p>B+ switch OFF</p> <p>Power switch OFF</p> <p>Damaged power connections or cable</p> <p>False connections due to loose solder or wire scrap</p> <p>2. Defective tubes</p> <p>Loose tube contacts</p> <p>Momentary grounds in antenna circuit</p> <p>Loose parts in receiver</p> <p>Poor connections in wiring</p> <p>Loose lamps or fuses in a-c supply</p> <p>Intermittently open and closed capacitors and resistors</p> <p>Loose ground or antenna posts ...</p> <p>Dust or foreign matter in main tuning capacitors</p> <p>Dirt on main tuning capacitor contacts</p> <p>3. Defective tubes</p> <p>Open filter capacitors</p> <p>Shorted filter choke</p> <p>Defective bypass capacitors or resistors</p> <p>4. Defective tubes</p> <p>Open bypass or filter capacitors ..</p> <p>Abnormal resistor values</p> <p>5. Defective c-w oscillator tube</p> <p>Defective h-f oscillator tube</p>	<p>1. Check tubes.</p> <p>Check antenna.</p> <p>Check antenna.</p> <p>Faulty wiring on headphones, faulty phone jack.</p> <p>Check voltage.</p> <p>Check voltage.</p> <p>Check point to chassis resistance values.</p> <p>Check gain per stage.</p> <p>Check control settings.</p> <p>Check for continuity.</p> <p>Check for continuity.</p> <p>Check cable continuity and plug.</p> <p>Examine leads and connections.</p> <p>2. Check tubes.</p> <p>Inspect tube fit in sockets.</p> <p>Check antenna leads and coils.</p> <p>Tap or shake each circuit element under suspicion and tighten or replace faulty part.</p> <p>Check outlets between fuse box and receiver. To check outside noise, disconnect the antenna and note change in noise level.</p> <p>Check voltage and resistance values, shunt suspected capacitor with test capacitor.</p> <p>Tighten posts and clean contacts.</p> <p>Remove dust from plates.</p> <p>Clean contacts with dry-cleaning solvent (SD).</p> <p>3. Check and replace tubes.</p> <p>Check voltage and shunt with test capacitor.</p> <p>4. Check tubes and replace.</p> <p>Check with shunt capacitor.</p> <p>Check i-f cathode resistors.</p> <p>5. Check tube.</p> <p>Check tube.</p>

Symptoms	Probable trouble	Corrections
6. Poor automatic volume control	6. Incorrect tube at positions V-1, V-2, V-5, or V-6	6. Check tube types.
7. Bad calibration	7. Tuning dial loose	7. Reset dial on zero with plates fully meshed. Check or realign.
8. C.W. OSC. inoperative	8. Shorted C-27 or trimmer	8. Check to see that the plates do not touch. Clean plates.
9. Improper operation of S-meter	9. Shorted S-meter rheostat	9. Check fiber washer for break and replace. Check voltage and resistance values and replace defective grid filter resistor.
10. Overheated output tube, screen, grid, or burned out tube	10. No load on output stage	10. Connect speaker terminals with a jumper if phones are used and if loudspeaker is not connected. When no phones are plugged in, apply load to speaker terminals before B+ is turned on.

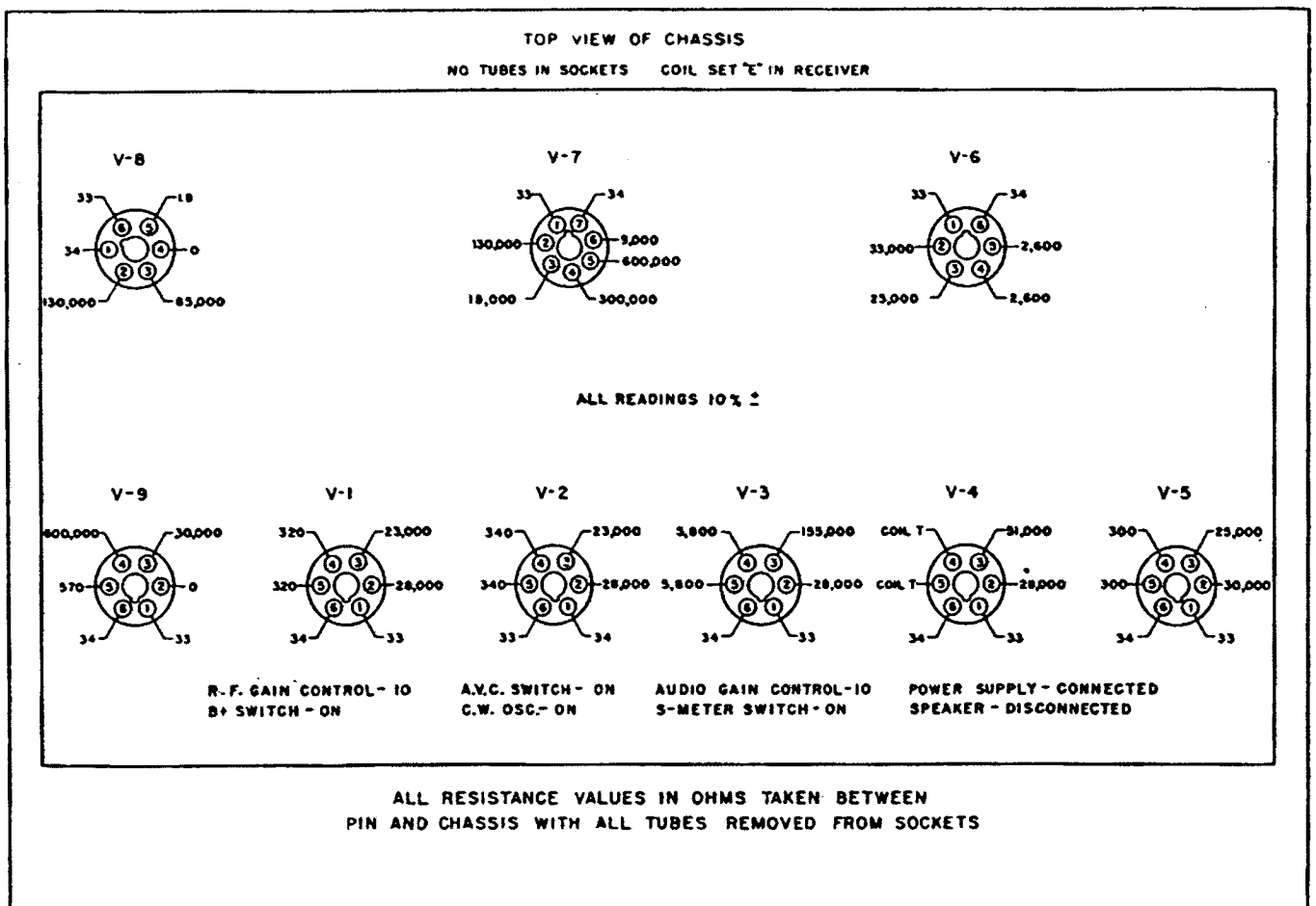

TL123905

Figure 35. Radio Receiver R-140/FSM-1 (with glass tubes), and National HRO-M type receivers, point-to-chassis resistance values.

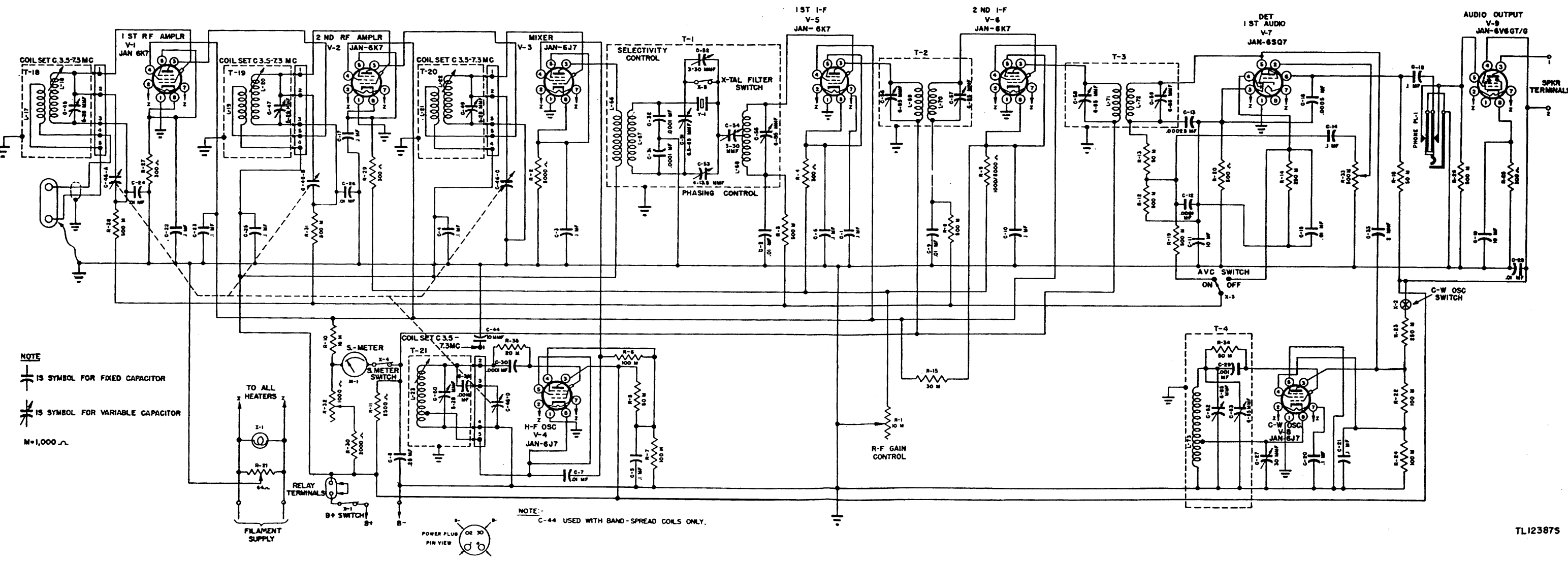

Figure 36. Radio Receiver R-140/FSM-1 (with metal tubes) and National HRO-5 series

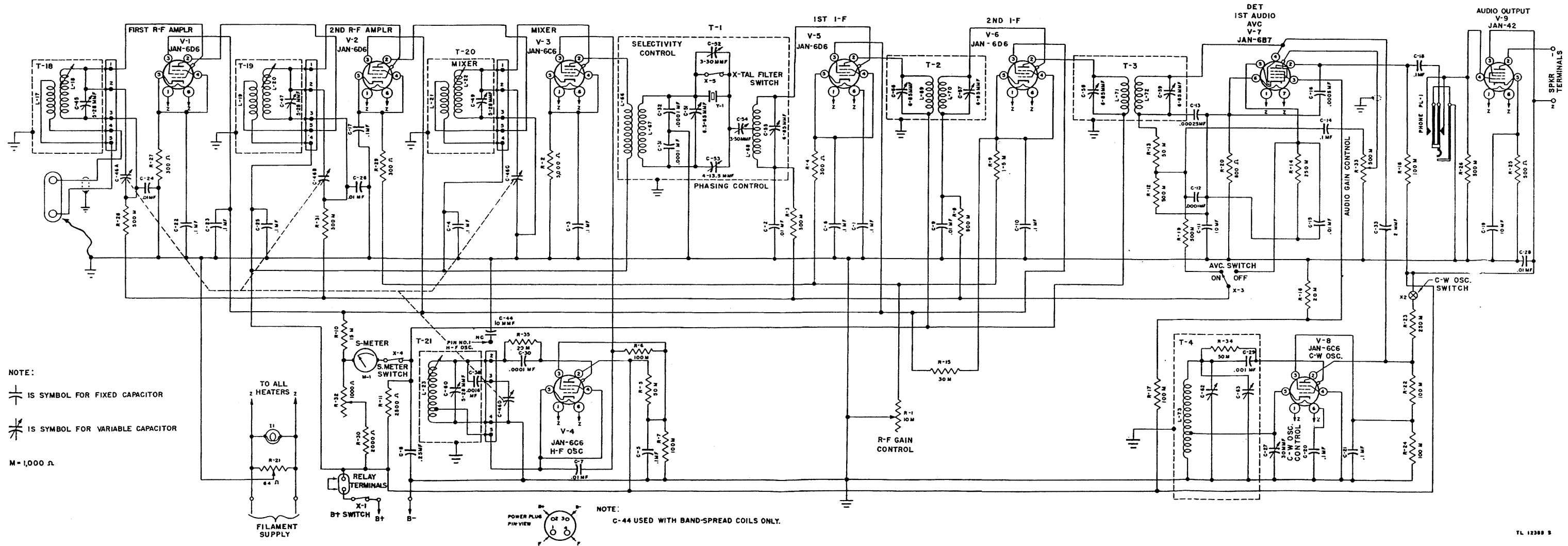

Figure 37. Radio Receiver R-140/FSM (with glass tubes) and National HRO-M series receivers - schematic wiring diagram

60. Tube Socket Voltage Measurements

A check of the voltages between each tube socket terminal and ground (chassis) is an efficient method of isolating a defective stage. A diagram to show tube socket voltage measurements is given in figure 32 for the HRO-M series receivers and in figure 33 for the HRO-5 series receivers. These diagrams apply also to Radio Receiver R-140/FSM-1. The readings are to be made under the following conditions.

a. Readings are taken between tube socket terminal and chassis.

b. The voltmeter should have a resistance of 1,000 ohms per volt.

c. Values given in figures 32 and 33 are for two conditions:

(1) Readings above the line are taken with the R.F. GAIN control set at 0.

(2) Readings below the line are taken with the R.F. GAIN control set at 10.

61. Point-To-Chassis Resistance Measurements

After checking voltages, disconnect the power supply. Check the resistance values against the diagram shown in figures 34 and 35. The values given are approximate and will vary slightly with different receivers and test equipment.

a. All readings are taken between terminal point and chassis with the speaker disconnected and all tubes in their sockets.

b. Set controls as shown below for Radio Receiver R-140/FSM-1 (with metal tubes), and National HRO-5 type receivers:

Control	Setting
R.F. GAIN control	10
B+ switch	ON
A.V.C. switch	ON
C.W. OSC. control	ON
AUDIO GAIN control	10
S-meter switch	ON

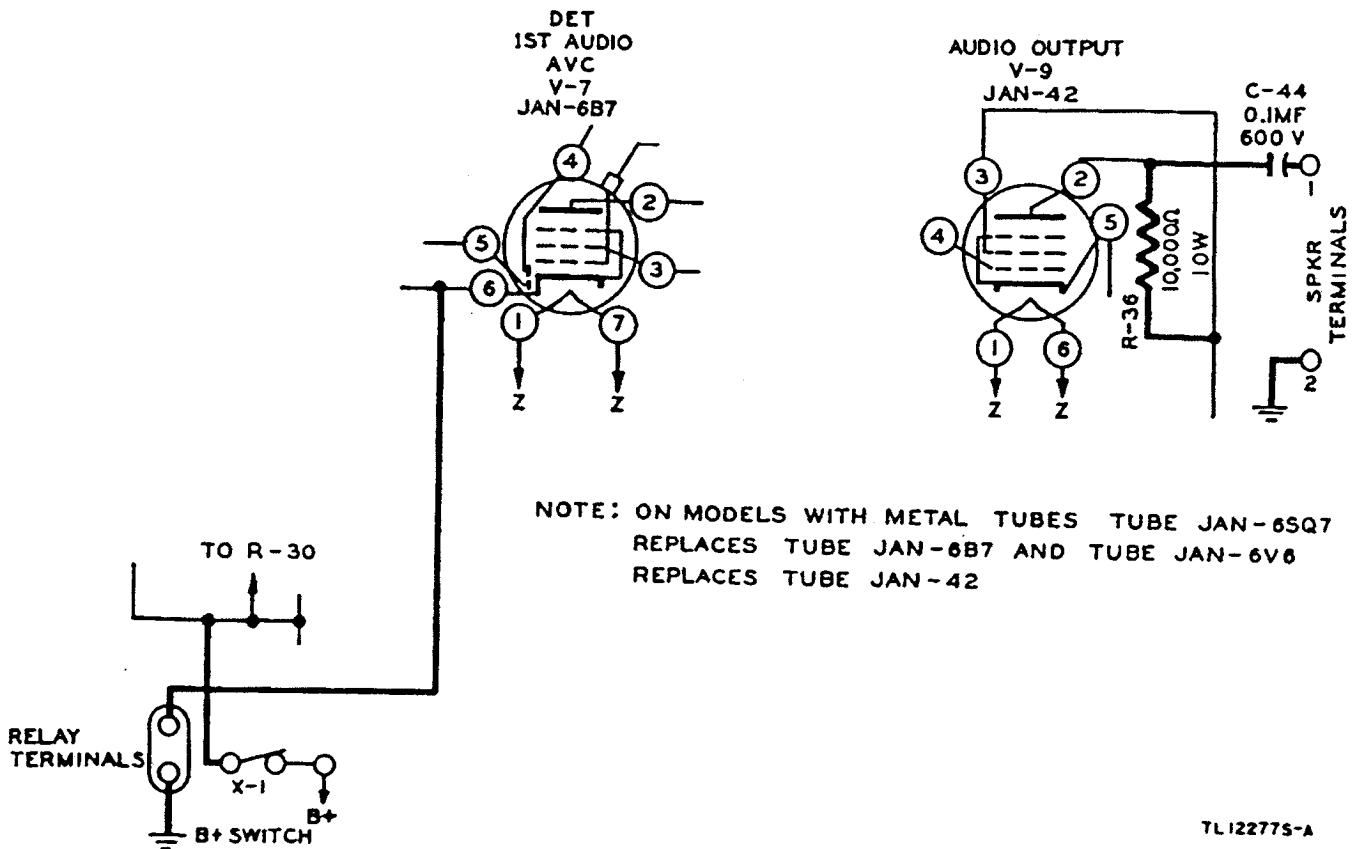

Figure 38. Diagram showing modification for Radio Receiver R-140/FSM-1.

TL12277S-A

c. Set controls as shown below for Radio Receiver R-140/FSM-1 (with glass tubes) and National HRO-M type receivers:

Control	Setting
R.F. GAIN control	10
A.V.C. switch	ON
AUDIO GAIN control	10
C.W. OSC. control	ON
S-meter switch	ON
B+ switch	ON
Power unit	Connected
Speaker	Disconnected
Coil set	Plugged in

(1) Pin 4 of V-9 reads zero ohms with phone plug in jack.

(2) Pin 2 of V-1 and V-2 will give no reading when coils are removed.

62. Voltage Gain Per Stage

The approximate signal voltage gain per stage for any given signal generator output to the receiver is shown in the table below.

From	To	Approximate voltage gain
Antenna terminal	1st r-f grid	8.
1st r-f grid	Mixer grid	25.
Mixer grid	1st i-f grid	9.
1st i-f grid	2d i-f grid	45.
2d i-f grid	Detector grid	11.5
Detector grid	Audio output grid	13.
Audio output grid	Audio output plate	17.5

1 Gain of the two r-f stages. The individual stage gain figures vary with different frequencies between approximately 2 and 15.

The signal generator output impedance is 37.5 ohms. The receiver output impedance is 5,000 ohms.

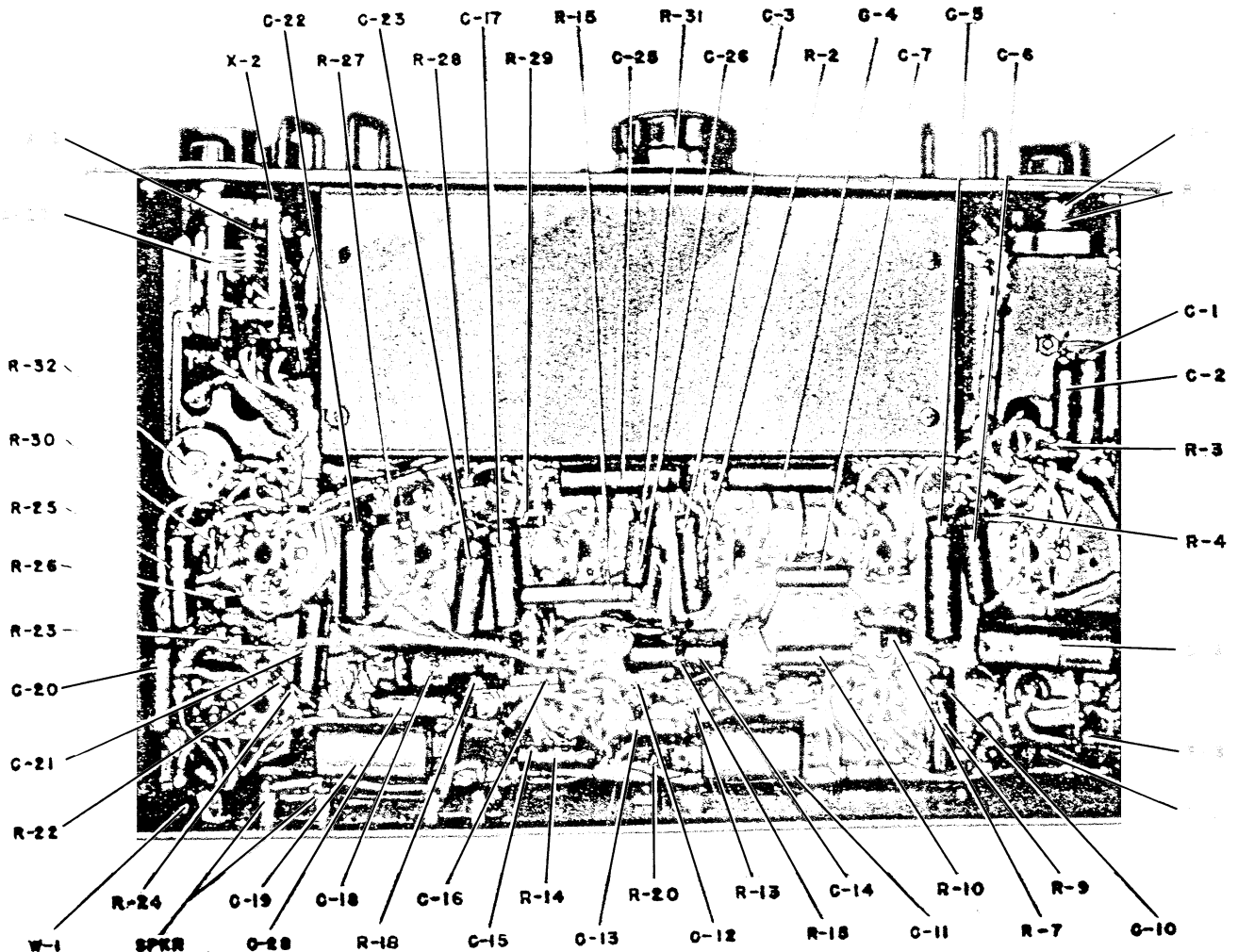

Figure 39. Receiver location of parts.

63. Test Equipment

The equipment listed below or its equivalent, is used for testing Radio Receiver R-140/FSM-1, and National receivers of the HRO series.

a. Test Set I-56, TS EV-10MCP or TS 110.

b. Signal Generator GR-605-B, 19X, 177X or 188X.

64. Illustrations and Schematic Diagrams

The illustrations and diagrams in this section are included as an aid in trouble shooting and repair of Radio Receiver R-140/FSM-1 (National HRO series of receivers), and if properly used will greatly facilitate servicing.

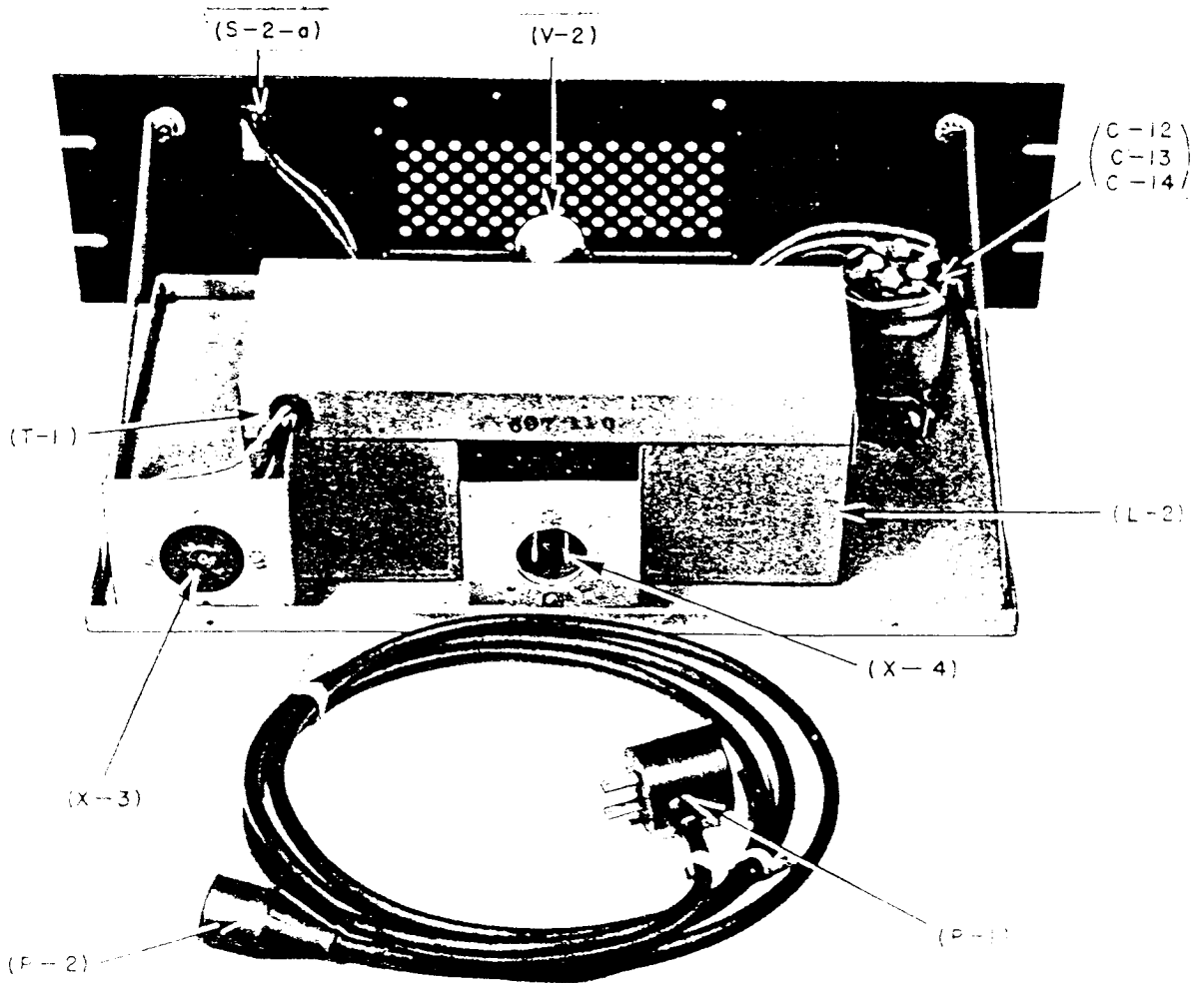

Figure 40. Power Supply SPU-697, parts location

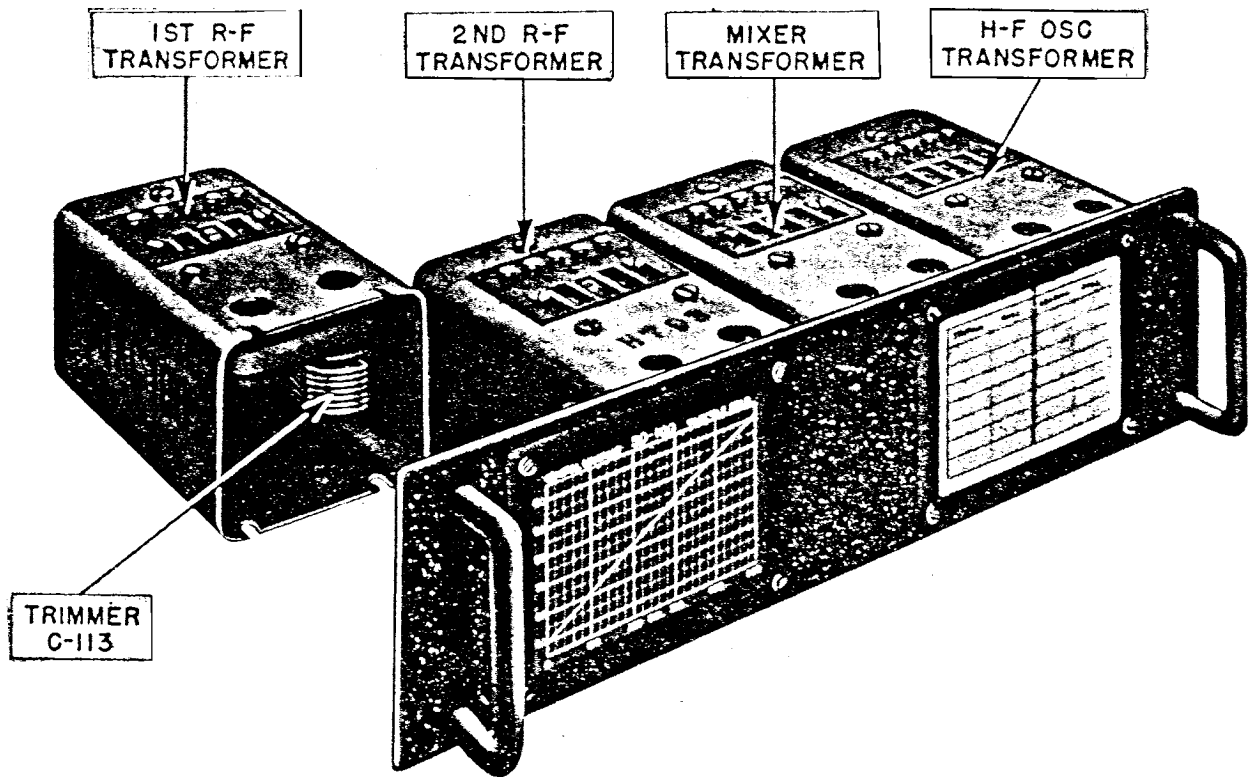
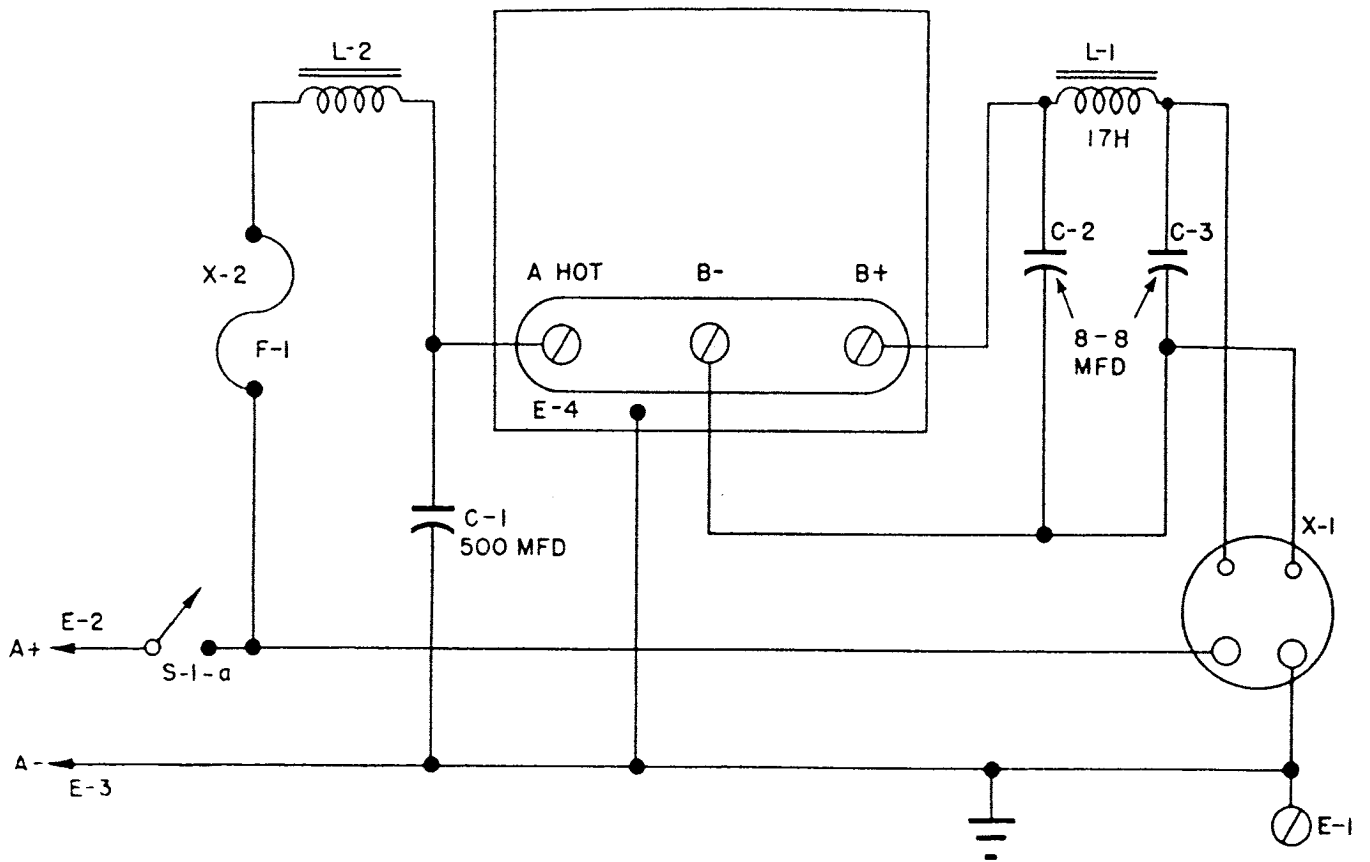
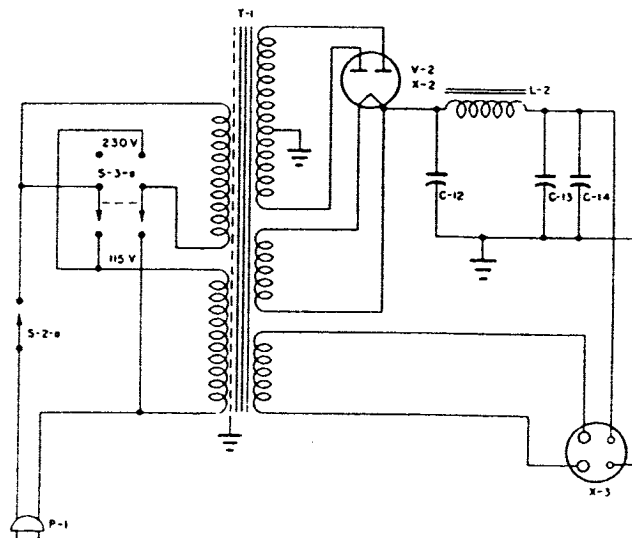

Figure 41. Coil set with first r-f transformer exposed.



TL12392S

Figure 42. 6.3 volt d-c power supply types 686-S, and SPU-686-S—schematic wiring diagram.



TL 12393 S

Figure 43. 115-230 volt 50-60 cycle a-c power supply types 697, and SPU-697—schematic wiring diagram. (Note: Rectifier Power Unit, Navy type No. 20090 does not have Switch S-3-a.)

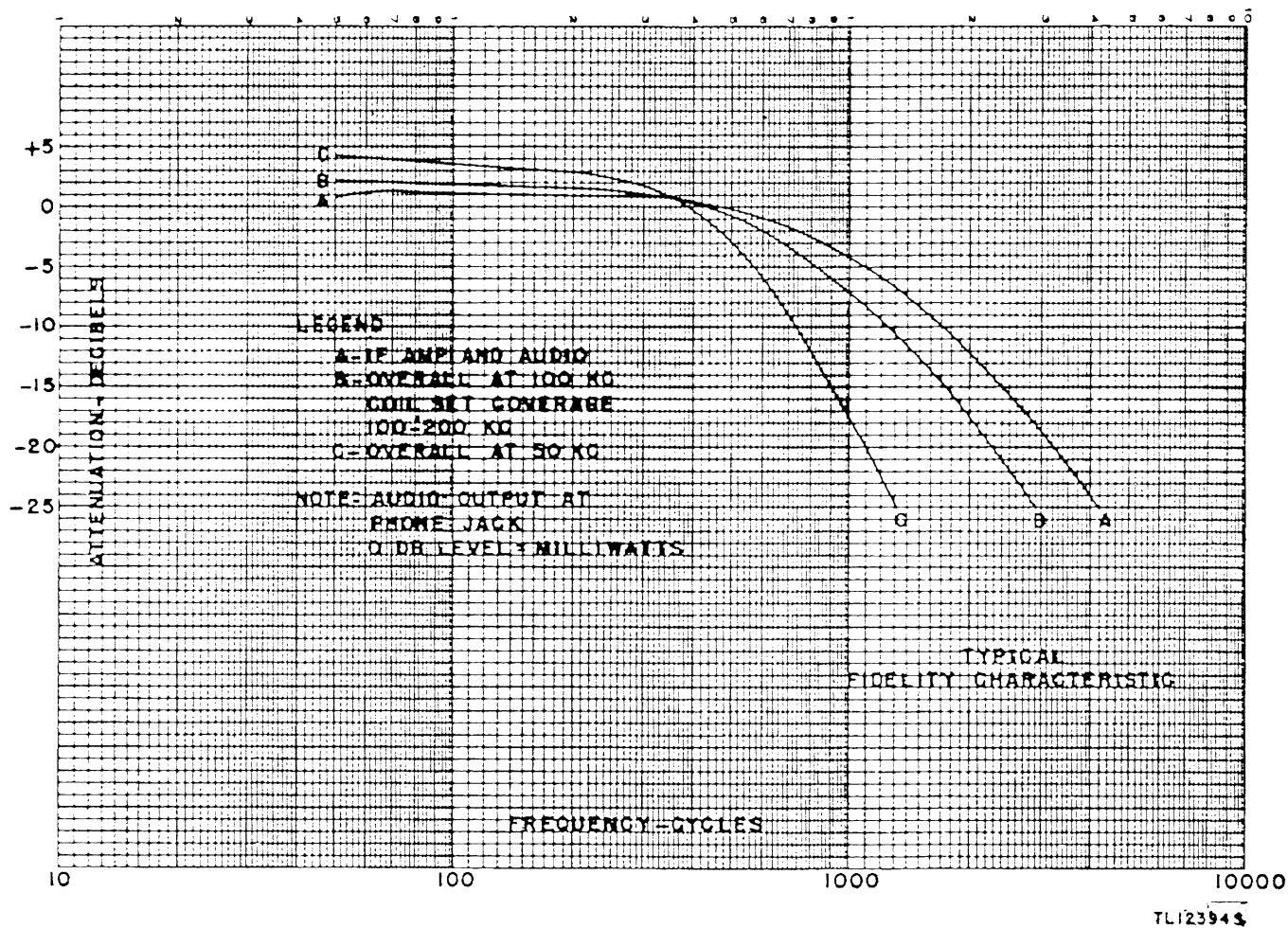
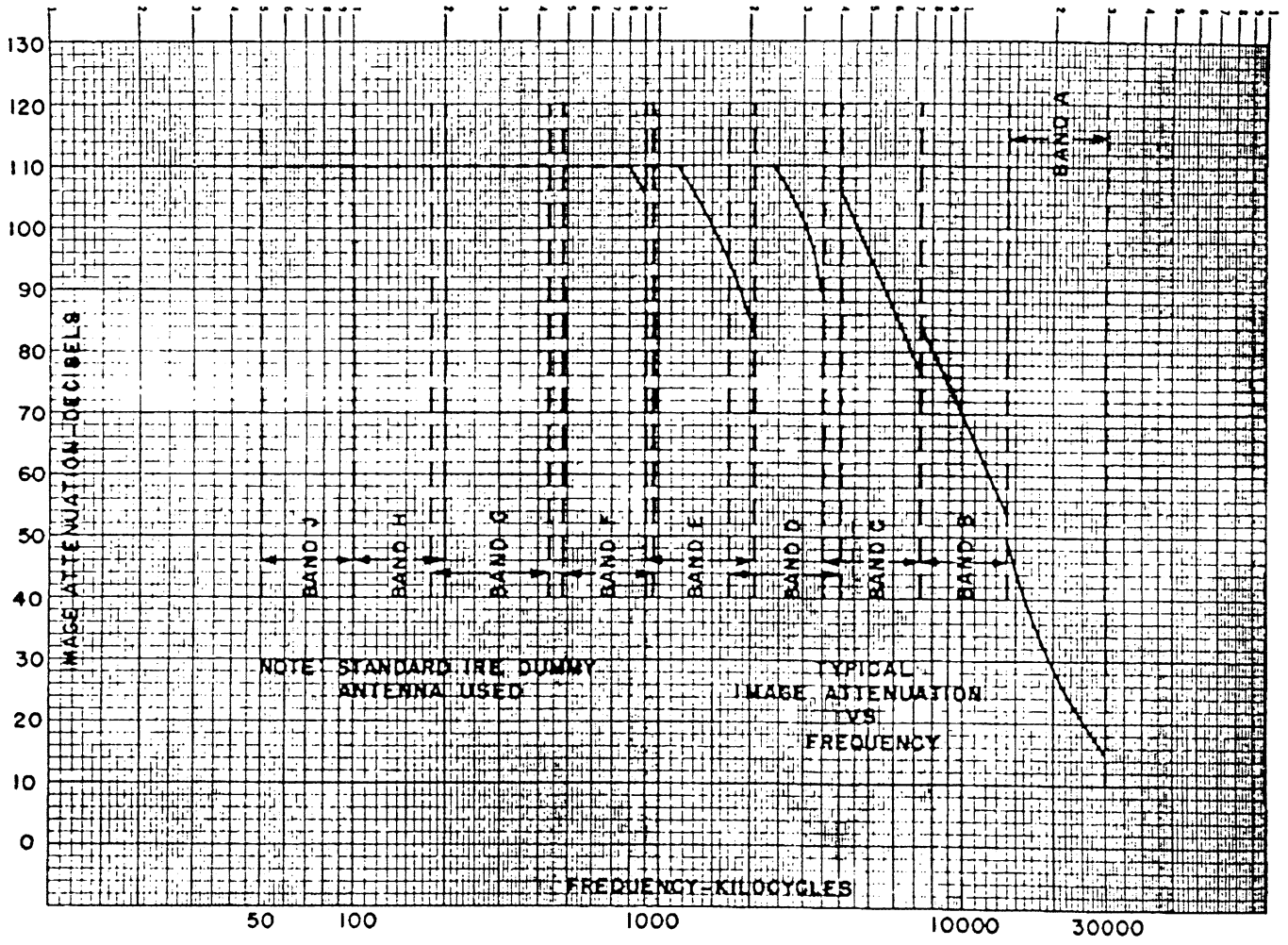

Figure 44. Receiver fidelity characteristic curve.



TL123955

Figure 45. Image attenuation curve.

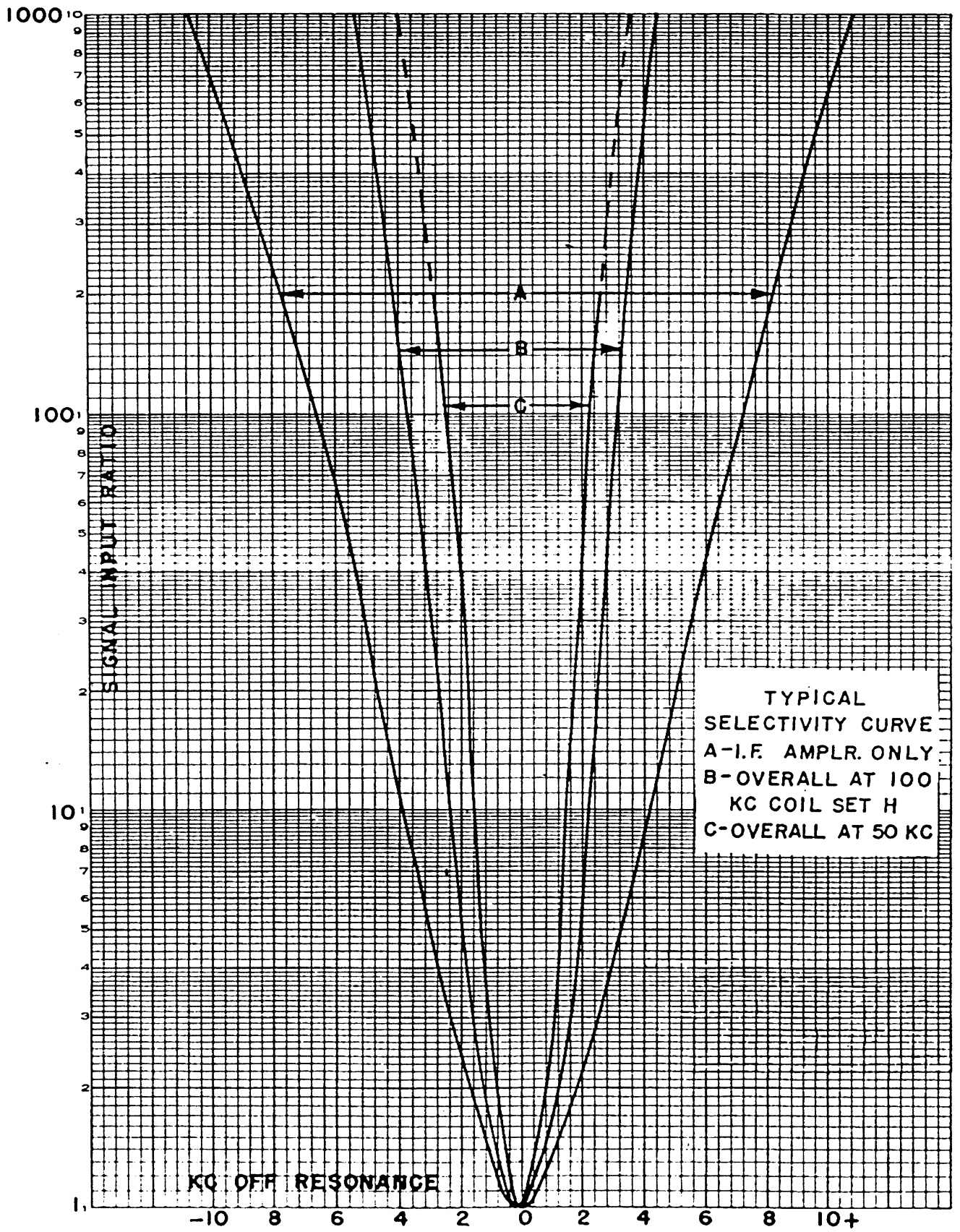
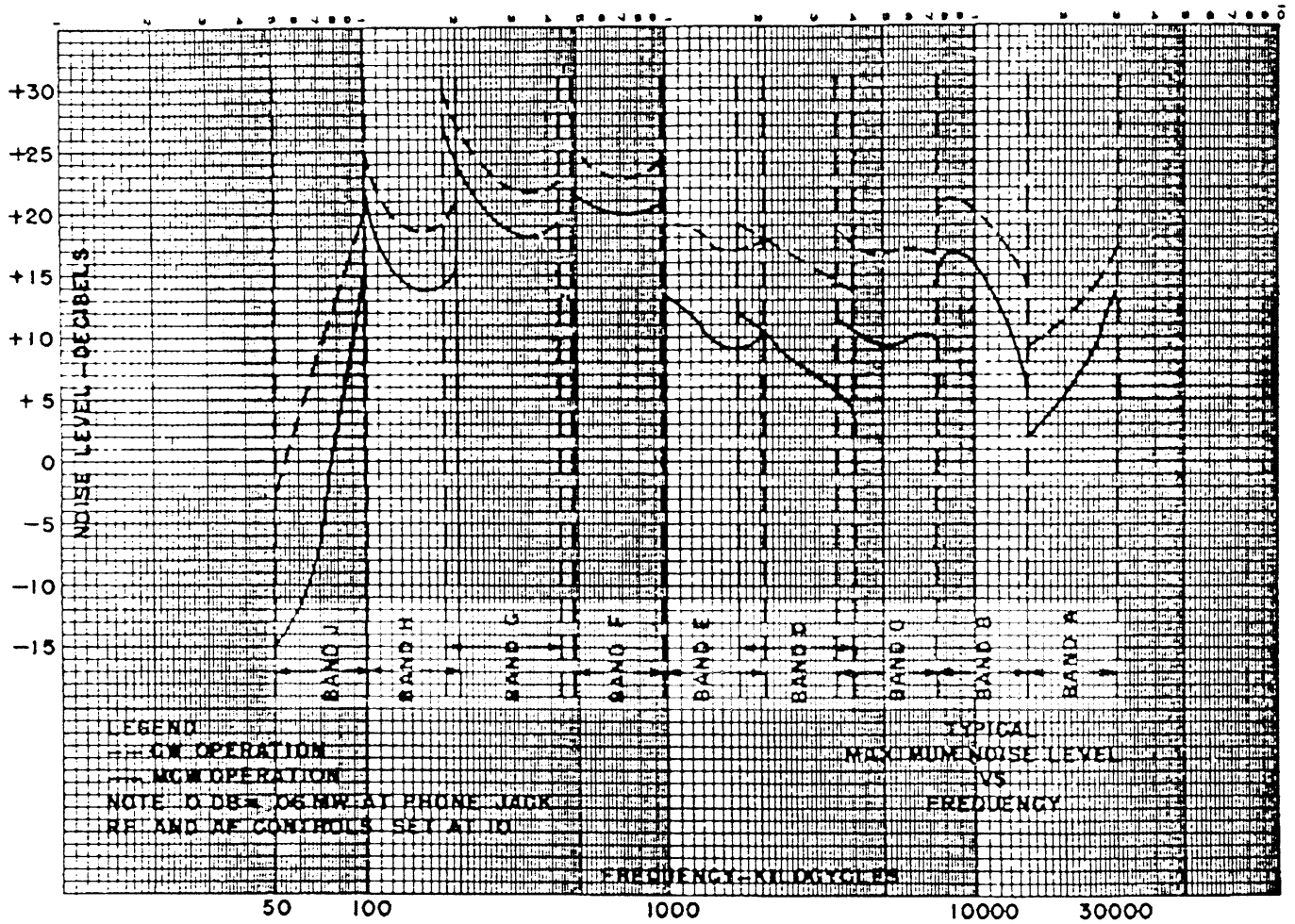

Figure 46. Typical receiver selectivity curve.

TL12396S



TL123975

Figure 47. Typical maximum noise level versus frequency curve.

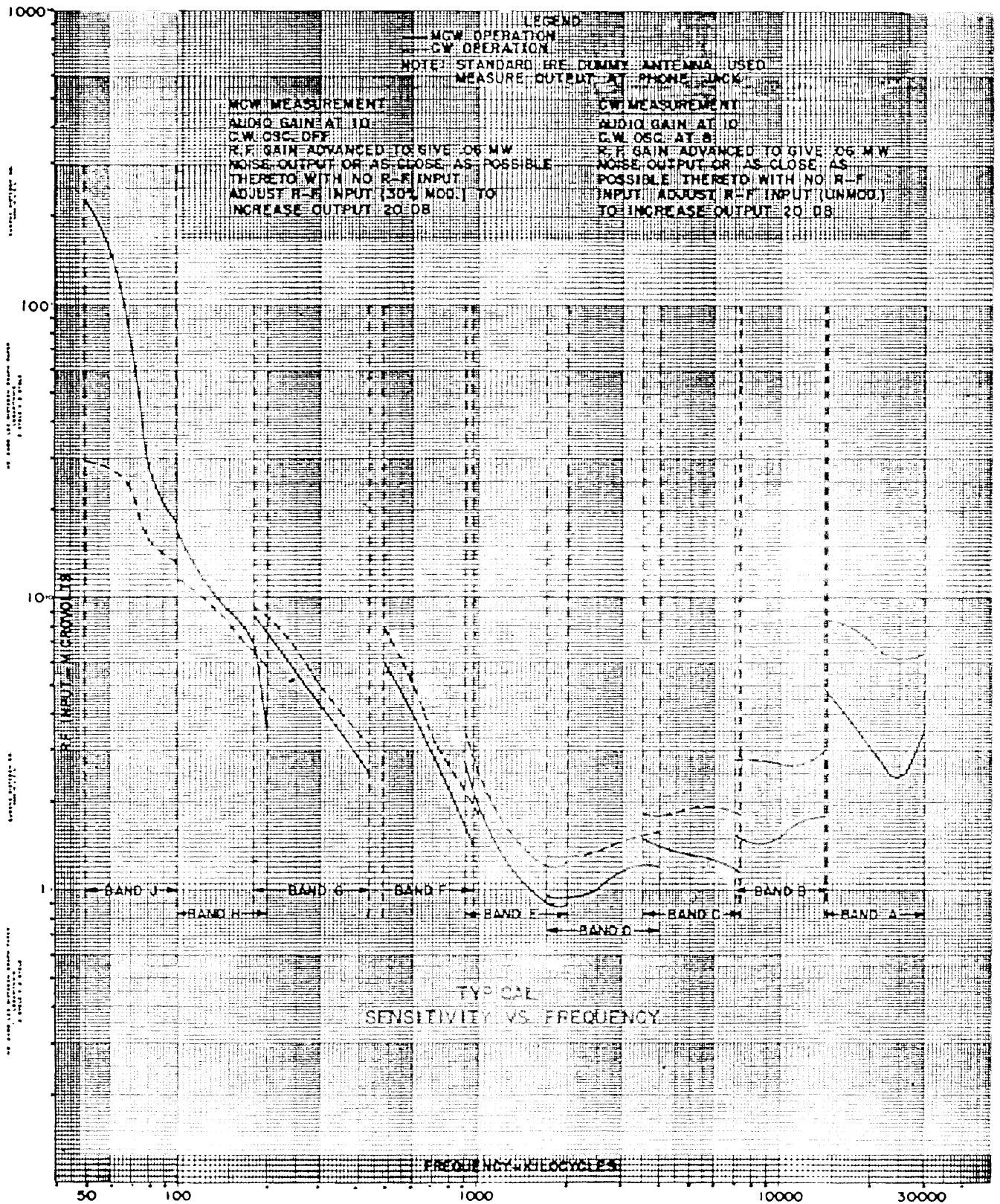

TL12398S

Figure 48. Typical sensitivity versus frequency curve.

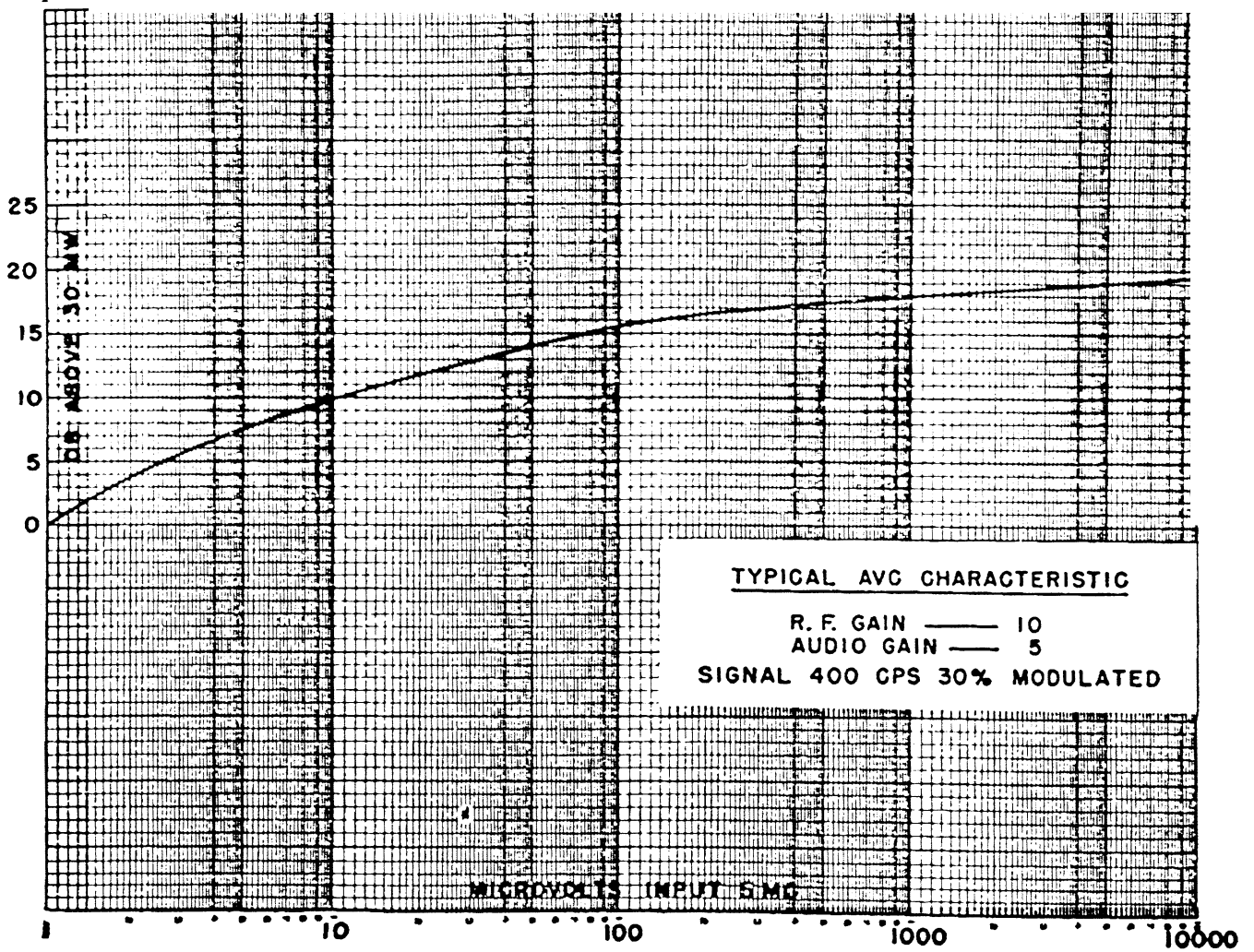

TL12399S

Figure 49. Typical a-v-c characteristic curve.

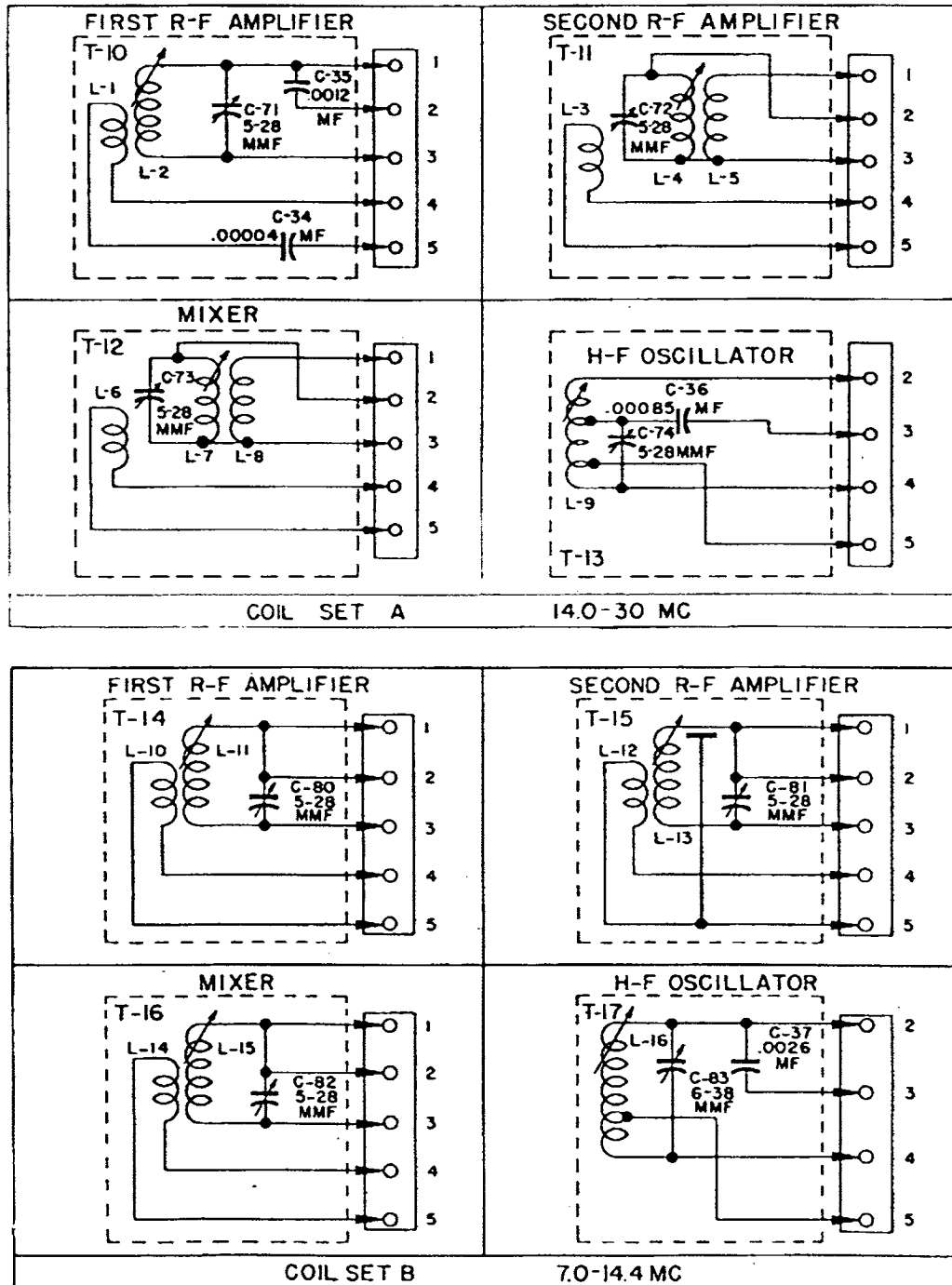

TL12400S

Figure 50. Coil sets A and B—schematic wiring diagram.

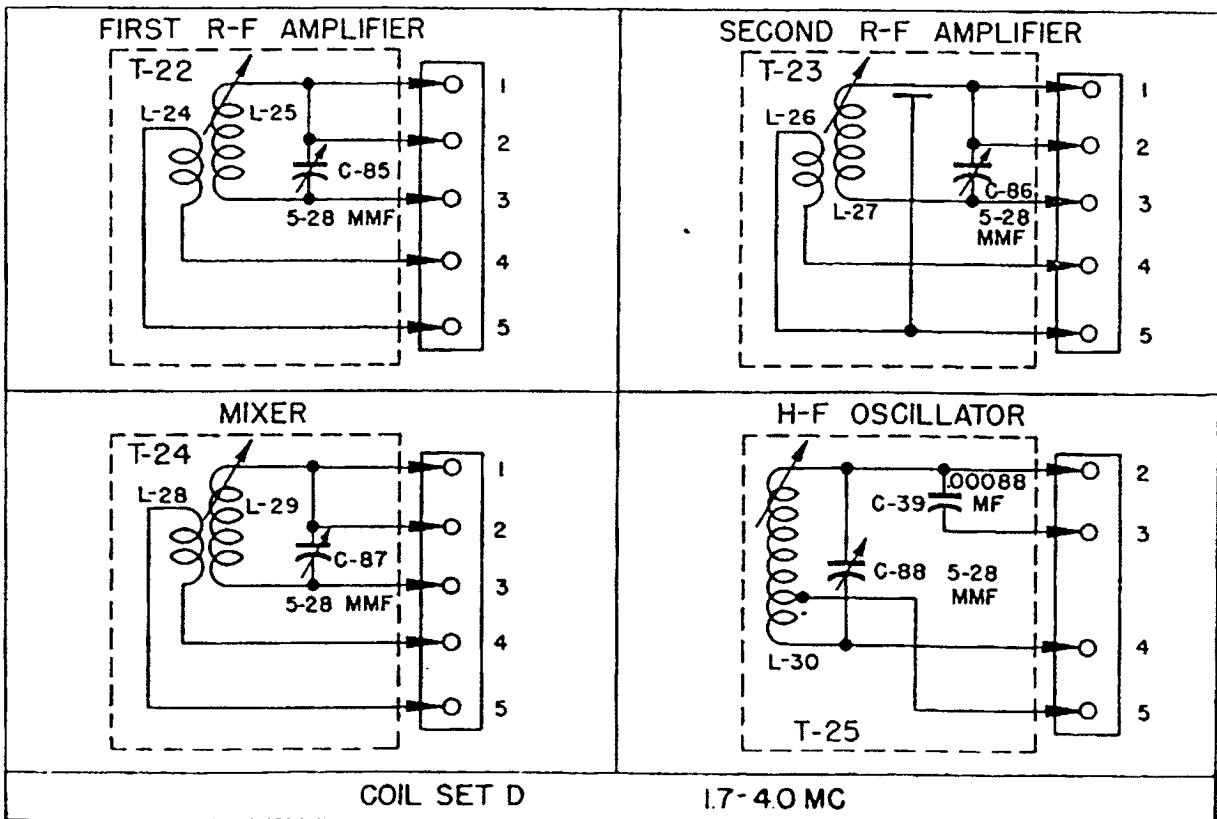
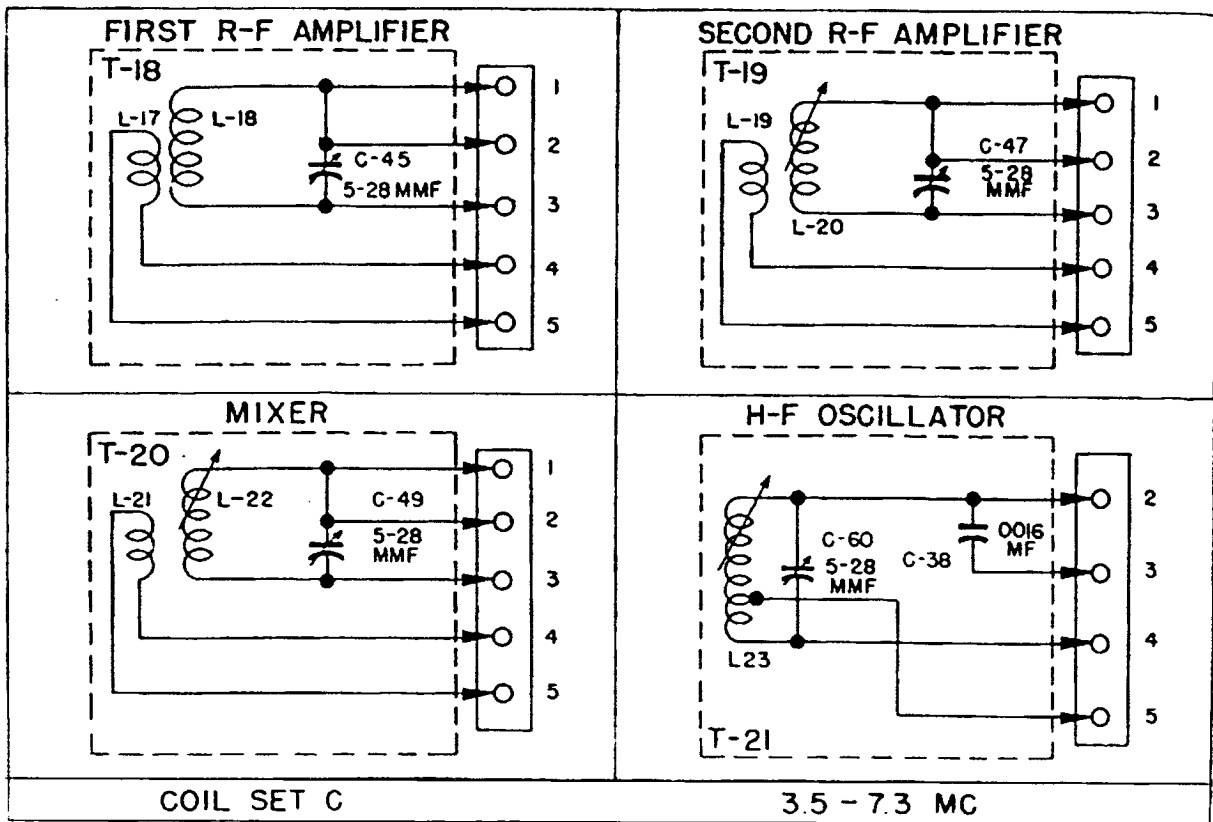

TL 124015

Figure 51. Coil sets C and D—schematic wiring diagram.

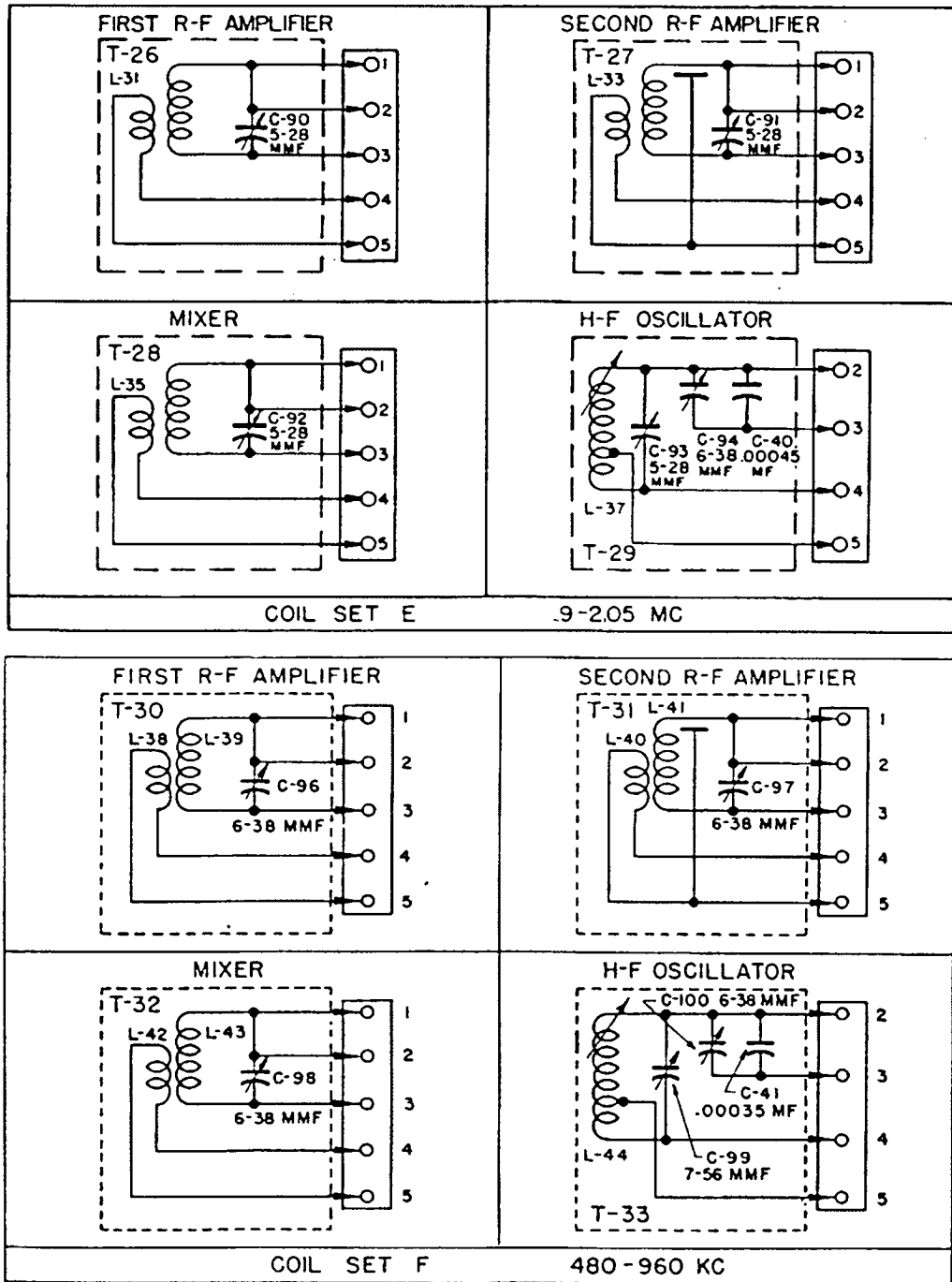

TL12402S

Figure 52. Coil sets E and F—schematic wiring diagram.

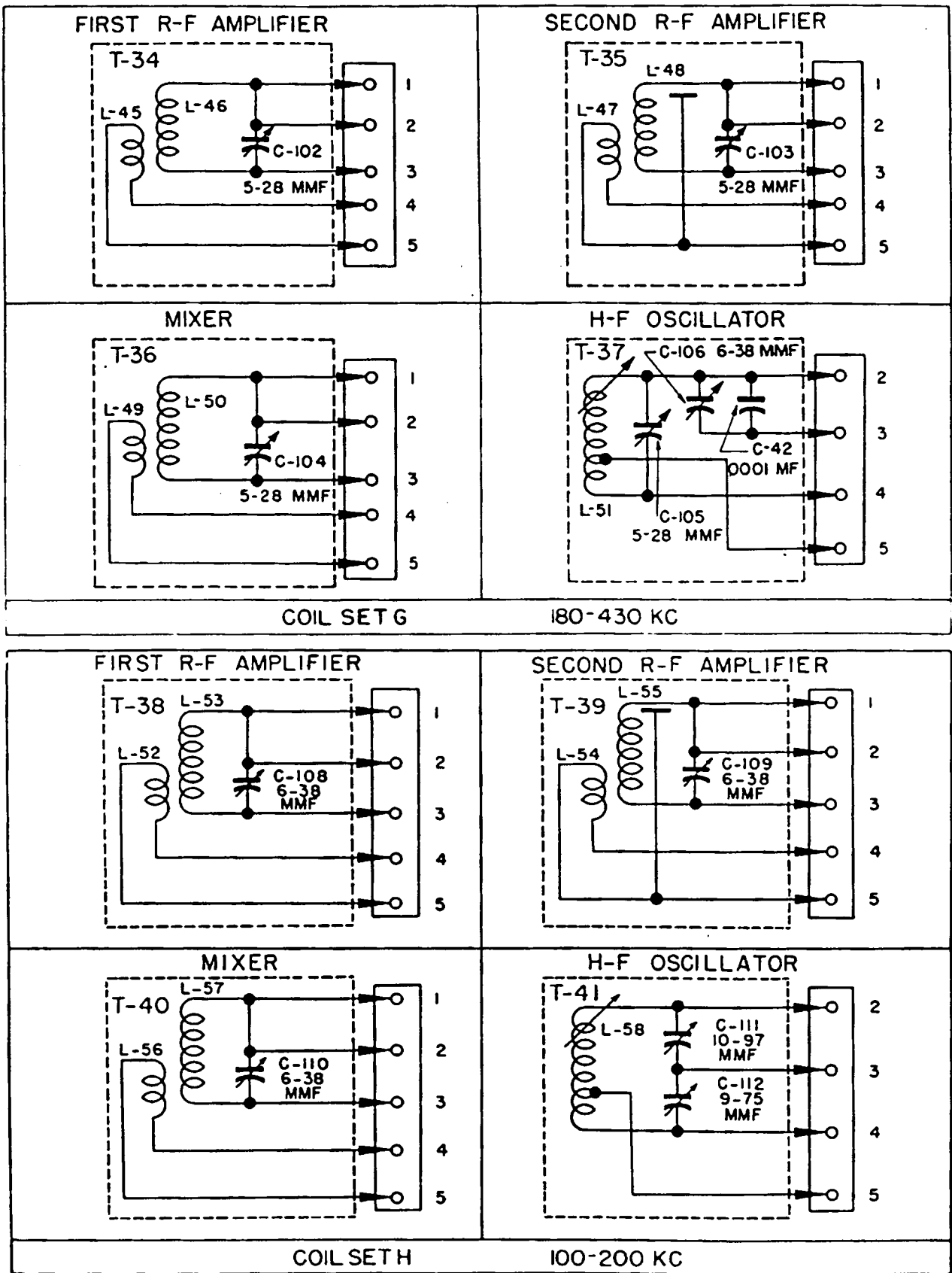
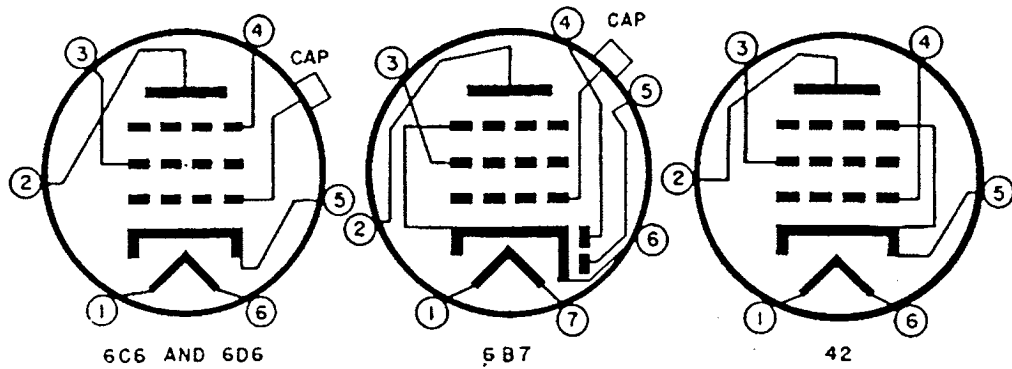

Figure 53. Coil sets G and H—schematic wiring diagram.

TL 12403-S



TL124045

Figure 54. Radio Receiver R-140/FSM-1 (with glass tubes), and National HRO-M type receivers, tube diagram.

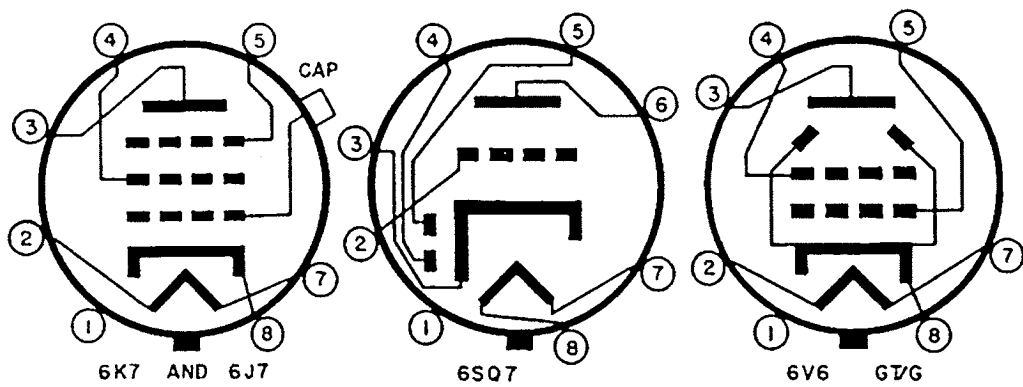

TL124055

Figure 55. Radio Receiver R-140/FSM-1 (with metal tubes), and National HRO-5 type receivers, tube diagram.

Section XII. REPAIRS

65. Rustproofing and Repainting

When the finish on the case has been badly scarred or damaged, rust and corrosion can be prevented by touching up bared surfaces as follows:

a. Use No. 00 or No. 000 sandpaper to clean the surface down to bare metal. Obtain a bright smooth finish.

Caution: The use of steel wool, although permitting rapid removal of rust, is not recommended. Minute particles of steel wool frequently enter the circuits and cause harmful internal shorting or grounding of circuits.

b. When a touch-up job is necessary, apply paint with a small brush. When numerous scars and scratches warrant complete repainting, remove the radio set chassis and spray paint over the entire case. Remove rust from the case by cleaning corroded metal with dry-cleaning solvent (SD). In severe cases it may be necessary to use dry-cleaning solvent (SD) to soften the rust and use sandpaper to complete the preparation for painting. Paint used will be authorized and consistent with existing regulations.

66. Unsatisfactory Equipment Report

a. When trouble in equipment used by the Army Ground Forces technical services occurs more often than repair personnel feel is normal, WD AGO Form 468, Unsatisfactory Equipment Report should be filled out and forwarded through channels to the Office of the Chief Signal Officer, Washington 25, D. C.

b. When trouble in equipment used by Army Air Forces occurs more often than repair personnel feel is normal, Army Air Forces Form 54, Unsatisfactory Report, should be filled out and forwarded to the Commanding General, Air Matériel Command, Wright Field, Dayton, Ohio, in accordance with AAF Regulation No. 15-54. If form is not available, prepare the data according to the sample form reproduced in figure 57.

Section XIII. ALIGNMENT AND ADJUSTMENT

67. Correct Methods of Alignment and Adjustment

a. GENERAL. All alignment adjustment points on Radio Receiver R-140/FSM-1 (National

HRO series of receivers) are located inside the cabinet, on the top of the chassis. All points are exposed and easily reached when the hinged cabinet lid is raised. (See fig. 58.) The complete alignment is divided into four parts as follows:

- (1) I-f amplifier alignment.
- (2) H-f oscillator alignment.
- (3) R-f amplifier alignment.
- (4) Tracking of h-f oscillator and r-f amplifier circuits.

b. PREPARATION OF RECEIVER FOR ALIGNMENT. (1) Connect the high-output lead from a signal generator to the point indicated for circuit to be aligned.

(2) Connect the signal generator ground lead to the receiver chassis.

(3) Plug the output meter prods into the speaker tipjacks.

(4) Plug the power cable into the proper power supply.

(5) Follow the procedure outlined below for aligning circuits.

c. I-F AMPLIFIER ALIGNMENT. (1) Connect the high-output lead from a signal generator to the grid cap of V-3, after the flexible grid lead has been disconnected.

(2) Insert a coil set and set receiver controls as follows:

Control	Setting
A.V.C. switch	OFF
R.F. GAIN control	9
PHASING control	5
Selectivity control	Maximum to left or right
AUDIO GAIN control	Advance for suitable reading
C.W. OSC. control	8 or 9 for audio beat

(3) With signal generator modulation off, tune the generator slowly between the frequencies of 450 kc and 460 kc until a sharply peaked response is indicated on the output meter. This peak response occurs at the exact frequency of the crystal and the generator should remain tuned to this frequency.

(4) Adjust the i-f trimmers, numbers 10, 11, 12, 13, and 14 for maximum output meter reading. The order of adjustment is unimportant. Trim each point and repeat if neces-

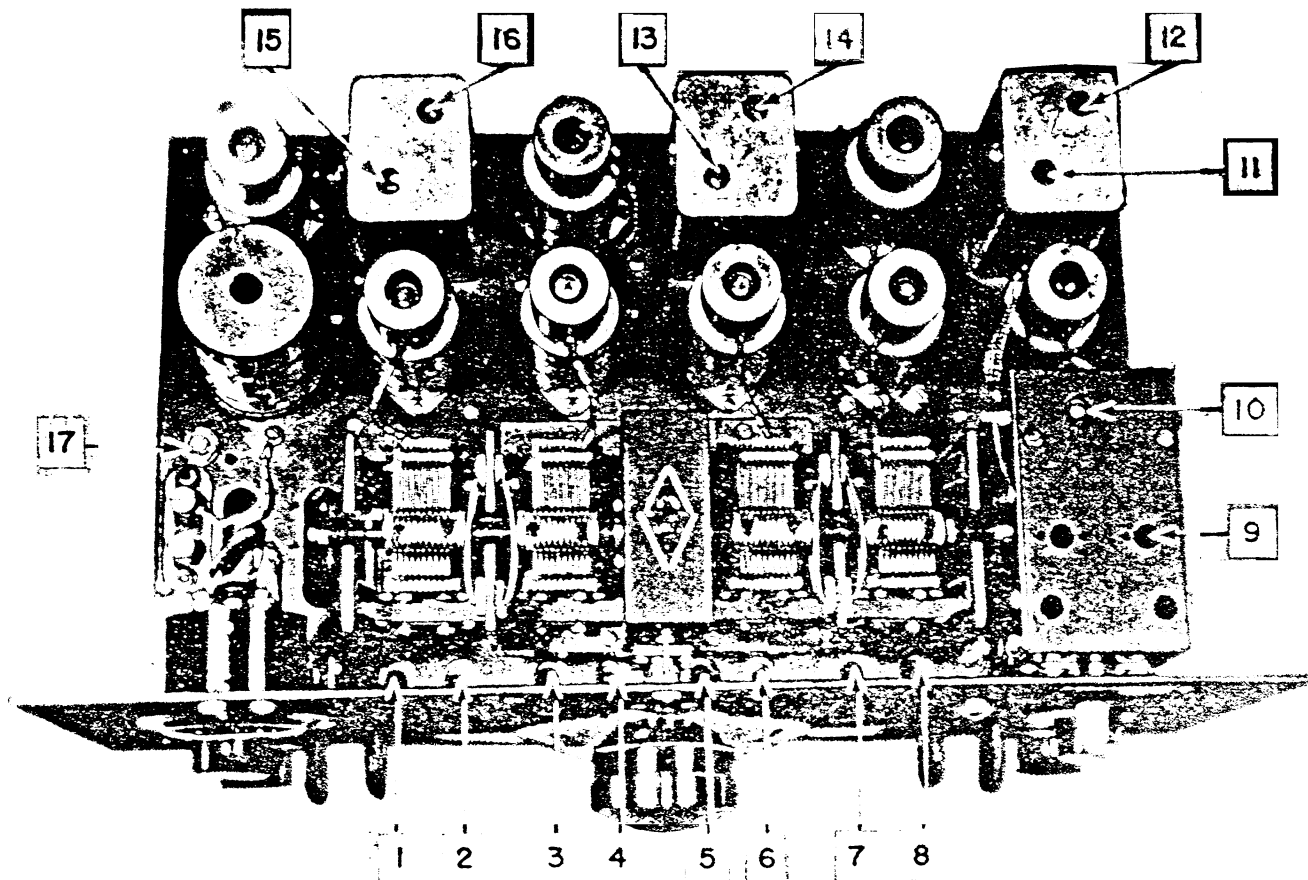

Figure 58. Chassis alignment points.

sary for maximum meter readings. Reduce signal input as alignment progresses to avoid overloading the detector or audio stages.

(5) With the generator still set at the crystal peak frequency, check the tuning of the C.W. OSC. control as given below.

(a) The PHASING control should be set at zero and the C.W. OSC. control at 9 for zero beat.

(b) Adjust trimmer capacitors C-62 and C-63 in T-4 for zero beat with the generator frequency.

(c) With the generator disconnected and the Selectivity control at maximum gain, adjust the C.W. OSC. control and note that the background noise is at its lowest pitch when the C.W. OSC. control is set at 9.

(d) Repeat this test with the crystal filter adjusted for maximum selectivity: lowest pitch of background noise should occur at same setting of C.W. OSC. control.

d. H-F OSCILLATOR ALIGNMENT. The need

for h-f oscillator alignment is indicated if the frequency calibration of the coil set is found to be in error more than 5 divisions (plus or minus) at dial settings between 480 and 490.

(1) Prepare receiver and set controls as given in c (2) above but with crystal filter OFF and Selectivity control set for maximum gain.

(2) Connect the high-output lead from a signal generator to the antenna binding post through a standard dummy antenna.

(3) Set the generator for a signal frequency which can be received with a dial setting near 490 as shown on calibration curve of the coil set.

(4) Adjust trimmer number 8, see figure 58, to adjust the dial calibration.

(5) To check the correct frequency of the h-f oscillator, tune the signal generator to the image frequency which is 912 kilocycles higher than the receiver dial frequency. If the image signal appears at a lower signal generator dial setting, the frequency is incorrect and trimmer

number 8 must be adjusted by decreasing capacitance until the real signal and image signal appear at the proper points on the dial.

e. R-F AMPLIFIER ALIGNMENT. (1) Disconnect the signal generator and plug in a set of headphones.

(2) Adjust the receiver as directed in *c* (2) above, with no antenna and with the crystal filter OFF, and Selectivity control set for maximum gain.

(3) Turn the main tuning dial to 490.

(4) Adjust trimmers 2, 4, and 6 for maximum background noise, which is the setting for maximum gain.

f. TRACKING OF H-F OSCILLATOR AND R-F AMPLIFIER CIRCUITS. (1) Tracking of the h-f oscillator and r-f amplifier circuits may be checked by observing the background noise while tuning throughout the range of the coil set in use. Background noise should not vary greatly as the dial is turned toward the low-frequency limit of the coil set tuning range. The tracking of each stage near the low-frequency limit of the tuning range may be checked by pressing the outside rotor plates of the main tuning capacitor section to or away from the stator. Be careful not to short the capacitor or permanently bend the motor plates. Any change in capacity should decrease the background noise indicating decreased sensitivity, if the stage is tracking properly. Coil sets which may require precise adjustment of circuit elements are provided with adjustable series padders in the h-f oscillator portion of the coil set. These can be adjusted to track with the average adjustment of the r-f amplifier coils. This series padder is mounted inside the coil and is adjustable from the rear by means of a screwdriver. On the higher frequency coils, adjustment of the high-frequency oscillator inductance performs a similar function.

(2) After calibration and alignment at the high-frequency end of the coil set has been adjusted, the tracking may be adjusted as follows:

(a) When r-f alignment has been completed, turn the receiver dial to 20.

(b) Test the tracking of each stage in turn by bending the outside rotor plate of each section of the main tuning capacitor and note any maladjustment. *Do not* bend the rotor plate of any section to such an extent that it will not spring back to its original position.

(c) Adjust the h-f oscillator series padder to its optimum tracking position when step *b* gives indication of poor tracking.

(d) Turn the receiver dial to 490 and adjust trimmer number 8 to give the proper calibration with the new value of the series padder.

(e) Repeat this procedure until best tracking has been accomplished.

(f) Note any slight tracking errors occurring in the r-f amplifier stages. If the same error occurs in a majority of the coil sets, the outside rotor plate may be permanently bent to provide the best tracking for that stage.

68. Test Instruments Used for Alignment and Adjustment

a. The following test equipment should be used for alignment and adjustment of Radio Receiver R-140/FSM-1.

(1) Signal Generator I-72-() covered by TM 11-307.

(2) Output meter, part of Test Sets I-56-K, covered by TM 11-322.

69. Minimum Test Requirements

The data in paragraph *b* below is intended as an aid in trouble shooting and is to be used as a guide in determining the quality of a repaired receiver.

a. INSTRUMENTS REQUIRED. (1) Signal generator with metered output covering frequencies from 50 kc to 30 mc. A generator similar to the equipment described in paragraph 68 is satisfactory.

(2) Output meter with 4,000-ohm impedance of a type similar to or the same as described in paragraph 68 is suitable.

Test	Signal generator control settings			Reading or result	Image frequency (mc)	Increased μV input for image response
	Attenuator setting (μV)	Frequency (mc)	Modulation Frequency Percentage			
1. SENSITIVITY	Set for: maximum input—					
	4 μV	29.00	400 30	1 watt	29.912	× 20 or more
	4 μV	14.00	400 30	1 watt	14.912	× 300 or more
	4 μV	7.00	400 30	1 watt	7.912	× 4000 or more
	4 μV	3.80	400 30	1 watt	4.712	× 104 or more
	4 μV	1.95	400 30	1 watt	2.862	× 104 or more
	4 μV	0.90	400 30	1 watt	1.812	× 104 or more
	3 μV	0.40	400 30	1 watt	1.312	× 104 or more
	3 μV	0.19	400 30	1 watt	1.102	× 104 or more
3 μV	0.09	400 30	1 watt	1.002	× 104 or more	
2. POWER OUTPUT	Set as necessary for output	4.00	400 30	2 watt		
3. A.V.C.	Set for 10 μV generator output increase to $10^5 \mu\text{V}$		400 30	Not more than 20db difference		
			400 30			
4. FIDELITY	Set for 100 μV generator output or more	4.00	1,000 30	0.0 db		
			100 30	0.5 ± 2 db		
			200 30	1.5 ± 2 db		
			400 30	2.0 ± 2 db		
			2,000 30	−6.5 ± 2 db		
			4,000 30	−21.0 ± 4 db		
5. CALIBRATION	Set for 10 μV or less generator output	30.0	400 30	Dial setting 485		
		14.4	400 30	Dial setting 485		
		7.3	400 30	Dial setting 490		
		4.0	400 30	Dial setting 490		
		2.0	400 30	Dial setting 470		
		0.9	400 30	Dial setting 436		
		0.4	400 30	Dial setting 450		
		0.2	400 30	Dial setting 490		
		0.1	400 30	Dial setting 490		
6. SELECTIVITY	Set generator for 10 μV output	0.456	400 30	Band width in kc:		
		2 × down receiver output V		Not less than 3.0 kc		
		10 × down receiver output V		Not more than 8.5 kc		
		100 × down receiver output V		Not more than 16.0 kc		
		1000 × down receiver output V		Not more than 25.0 kc		

b. MINIMUM TEST REQUIREMENTS.

LEGEND

Note: All tests made with 686-S or with 697 power supply. 500-ohm non-inductive resistor used as dummy antenna for all tests.

1. SENSITIVITY

- a. Connect signal generator to antenna post through 500-ohm resistor in series with the input lead.
- b. Set PHASING control to 0 position.
- c. Set selectivity control for maximum gain.
- d. Set A.V.C. switch to off position.
- e. Set C.W. OSC. control to off.
- f. Turn the S-meter off.
- g. Proceed in accordance with sensitivity test on chart.
- h. Advance the R.F. GAIN control for 10 mw with signal generator turned off.
- i. Advance the AUDIO GAIN control at 10.

2. POWER OUTPUT.

- a. Connect signal generator directly to the antenna post.
- b. Set R.F. GAIN control at 10.
- c. Set AUDIO GAIN control at 10.
- d. Adjust selectivity control for maximum gain.
- e. Set A.V.C. switch to off position.
- f. Turn C.W. OSC. to off position.

- g. Set S-meter switch in off position.

h. Proceed in accordance with the output test on the chart.

3. A.V.C.

- a. Use same conditions as in power output test. A.V.C. switch ON.

- b. Proceed with test as shown on chart.

4. FIDELITY.

- a. Use same conditions as in output test.

- b. Proceed with test as shown on chart.

5. CALIBRATION.

- a. Use same conditions as power output test.

b. Tune for signals as given in chart. Dial readings should be within $\pm 3\%$ readings given on chart or curves.

6. SELECTIVITY.

- a. Connect generator to grid of mixer, V-3.

- b. Adjust generator for 10 microvolts (10 μv) output.

- c. Set AUDIO GAIN control at 10.

d. Adjust R.F. GAIN control for reference level output meter reading of 10 or 20 milliwatts.

- e. Adjust the Selectivity control for maximum gain.

f. Increase signal input to the receiver by steps as shown in chart without disturbing any settings.

- g. Proceed with test as shown on chart.

APPENDIX I

REFERENCES

1. Army Regulations

AR 380-5, Safeguarding Military Information.

2. Supply Publications

SIG 1, Introduction to WD Signal Supply Catalog.

SIG 2, Complete Index to WD Signal Supply Catalog.

SIG 3, List of Items for Troop Issue.

SIG 4-1, Allowances of Expendable Supplies.

SIG 4-2, Allowances of Expendable Supplies for Schools, Training Centers, and Boards.

SIG 5, Stock List of All Items.

SB 11-6, Dry Battery Supply Data.

SB 11-8, Chests for Running Spares for Radio Sets SCR-506-(), SCR-508-(), SCR-528-(), and SCR-538-().

SB 11-76, Signal Corps Kit and Materials for Moisture—and Fungi—Resistant Treatment.

3. Technical Manuals on Auxiliary Equipment and Test Equipment

TM 11-300, Frequency Meter Sets SCR-211-A, B, C, D, E, F, J, K, L, M, N, O, P, Q, R, T, AA, AC, AE, AF, AG, AH, AJ, AK, AL, and AN.

TM 11-303, Test Sets I-56-C, I-56-D, I-56-H, and I-56-J.

TM 11-307, Signal Generators I-72-G, H, J, and K.

TM 11-321, Test Set I-56-E.

TM 11-472, Repair and Calibration of Electrical Measuring Instruments.

TM 11-2606, Test Set AN/FSM-3, Tool Equipment TK-40/FSM-3, and Maintenance Kit MK-40/FSM-3.

TM 11-2613, Voltohmmeter I-166.

TM 11-2626, Test Unit I-176.

TM 11-2627, Tube Tester I-177.

4. Painting, Preserving, and Lubrication

TM 11-430, Batteries for Signal Communications, Except those Pertaining to Aircraft.

TB SIG 13, Moistureproofing and Fungiproofing Signal Corps Equipment.

TB SIG 69, Lubrication of Ground Signal Equipment.

5. Shipping Instructions

U.S. Army Spec. No. 100-14A, Army-Navy General Specification for Packaging and Packing for Overseas Shipment.

6. Decontamination

TM 3-220, Decontamination.

7. Demolition

FM 5-25, Explosives and Demolitions.

8. Camouflage

FM 5-20, Camouflage, Basic Principles.

9. Other Publications

FM 21-6, List and Index of War Department Publications.

FM 24-18, Radio Communication.

TB SIG 5, Defense Against Radio Jamming.

TB SIG 25, Preventive Maintenance of Power Cords.

TB SIG 66, Winter Maintenance of Signal Equipment.

TB SIG 72, Tropical Maintenance of Ground Signal Equipment.

TB SIG 75, Desert Maintenance of Ground Signal Equipment.

TB SIG 123, Preventive Maintenance Practices for Ground Signal Equipment.

TB SIG 178, Preventive Maintenance Guide for Radio Communication Equipment.

TM 1-455, Electrical Fundamentals.

TM 11-227, Signal Communication Equipment Directory, Radio Communication Equipment.

TM 11-310, Schematic Diagrams for Maintenance of Ground Radio Communications Sets.

TM 11-314, Antennas and Antenna Systems.

TM 11-453, Shop Work.

TM 11-455, Radio Fundamentals.

TM 11-462, Signal Corps Reference Data.

TM 11-483, Suppression of Radio Noises.

TM 11-499, Radio Propagation Handbook.

TM 37-250, Basic Maintenance Manual.

10. Forms

WD AGO Form 468, Unsatisfactory Equipment Report.

AAF Form 54, Unsatisfactory Report.

11. Abbreviations

A..... adjust.
a-c..... alternating-current.
a-f..... audio-frequency.
AGO..... Adjutant General's Office.
a-m..... amplitude-modulated.
a-v-c..... automatic-volume-control.
bfo..... beat-frequency oscillator.
C..... clean.

c-w..... continuous-wave.
d-c..... direct-current.
detectr..... detector.
F..... feel.
fig..... figure.
h-f..... high-frequency.
I..... inspect.
i-f..... intermediate-frequency.
in..... inches.
kc..... kilocycles.
L..... lubricate.
lb..... pounds.
mc..... megacycles.
m-c-w..... modulated-constant-wave.
 μ v..... microvolts.
mw..... milliwatts.
No..... number.
osc..... oscillator.
par..... paragraph.
r-f..... radio-frequency.
Sig C..... Signal Corps.
T..... tighten.
v..... volts.
WD..... War Department.

APPENDIX II

MAINTENANCE PARTS

I. Maintenance Parts for Radio Receiver R-140/FSM-1

The information below was compiled on 17 July 1945. The appropriate pamphlet of the WD Signal Supply Catalog for Radio Receiver R-140/FSM-1 is:

Higher echelon spare parts:

SIG 8-R-140/FSM-1.

SIG 8-R-140/FSM-1, Change 1.

For an index of available catalog pamphlets, see the latest issue of WD Signal Supply Catalog SIG 2.

Ref symbol	Signal Corps stock No.	Name of part and description
	2C4180-140	RADIO RECEIVER R-140/FSM-1: AM; operates on 115 v, 50/60 cyc; rack mtg; 19" lg x 10 1/4" d x 8 3/4" h over-all.
	2Z9405.45	BOARD, terminal (brushboard): 5 brush cont; molded bakelite; phosphor-bronze cont w/inlaid coin silver strips; 2 1/8" lg x 1 1/8" wd 1 3/4" thk; Natl Co #SA-22-G.
	2Z9402.98	BOARD, terminal: 2 nickel pl brass binding posts; molded polystyrene; 2 3/4" lg x 3/4" wd; Natl Co. #FWKSA:21 (antenna ground connection).
	2Z9402.1	BOARD, terminal: 2 pin type jacks bakelite; 2" lg x 1 1/2" wd x 3/4" d over-all; Cinch #1540 (speaker connection).
	2Z9402	BOARD, terminal: 2 screw type posts; bakelite; 2" lg x 1 1/2" wd x 3/4" thk; Cinch #1720 (external relay connection).
	3E4013-4	CABLE ASSEMBLY, power: cotton covered, rubber insulated; 3/8" diam; 5 ft lg; 2 #12 AWG and 2 #20 AWG stranded cond; Natl Co #C-627 (with standard four prong male rubber plugs Amphenol #PM-4-11 on one end; tinned leads on other end).
C11, 19	3DB10-47	CAPACITOR, fixed: electrolytic; 10 mf +150% -0%; 50 vdcw; case 1 1/4" lg x 4 1/8" diam; Dubilier part #FA-10003.
C33	3D9002-6	CAPACITOR, fixed: mica; 2 mmf; 400 vdcw; Natl Co type #B21.
C12, 30, 31, 32	3K2010114	CAPACITOR, fixed: mica; 100 mmf +20%; 500 vdcw; CM20A-101M.
C13	3K2024142	CAPACITOR, fixed: mica; 240 mmf ±5%; 500 vdcw; CM20D241J.
C16	3K2051112	CAPACITOR, fixed: mica; 510 mmf ±5%; 500 vdcw; CM20A511J.
C2, 7, 9, 15, 24, 26, 28	3DA10-196	CAPACITOR, fixed: paper; 10,000 mmf 20% -10%; 600 vdcw; case 3/8" diam x 1 1/4" h; Sprague type G.
C1, 3, 6, 10, 14, 17, 20, 21, 22, 23	3DA100-129.2	CAPACITOR, fixed: paper; 100,000 mmf +20% -10%; 400 vdcw; case 1 1/2" lg x 1/2" diam; Sprague type G.
C4, 5, 18, 25	3DA100-84.2	CAPACITOR, fixed: paper; 100,000 mmf +20% -10%; 600 vdcw; case 2" x 3/8"; Aerovox type #684.
C8	3DA250-73	CAPACITOR, fixed: paper; 250,000 mmf +20% -10%; 600 vdcw; case 2 1/2" x 1 1/8"; Sprague type G.
C27	3D9035V-33	CAPACITOR, variable: air dielectric; 5 to 35 mmf; 3 rotor, 3 stator plates; case 2 1/4" lg x 1 5/8" wd x 1 1/4" h over-all; Natl Co type #SA-13.
C46	3D9225V-7	CAPACITOR, variable: air dielectric; 4 sect; 12 to 225 mmf ea sect; 0.020" air gap; 10 rotor, 9 stator plates; case 9 1/8" lg x 5" wd x 3 1/2" h; Natl Co #SA14B (main tuning gang).
	2Z3764.26	DIAL ASSEMBLY, tuning: molded bakelite knob w/zinc dial: 4 1/2" diam for 1/8" shaft; Natl Co type NPW, #SA-645.
T1	3Z1891-19	FILTER, band pass: IF; 455 kc; 4 3/8" x 4 1/2" x 2 3/8" over-all; w/455 kc inclosed xtal; Natl Co type #SA-81.

Ref symbol	Signal Corps stock No.	Name of part and description
	2Z5598-8	JACK, telephone: single ckt; w/additional set of 1 break and 1 make cont; 1 1/8" d x 1 1/2" wd x 3/4" thk; Mallory #04A (headphone jack).
	2Z5824.19	KNOB, bar: molded black bakelite; for 1/4" diam shaft; single #8-32 setscrew; 1 1/4" lg x 1/2" wd x 5/8" d over-all; Natl Co type #SA:4 (audio gain).
	2Z5824.21	KNOB, bar: molded black bakelite; for 1/4" diam shaft; single #8-32 setscrew; 1 1/4" lg x 1/2" wd x 5/8" d over-all; Natl Co #SA:6 (control for CWO).
	2Z5824.22	KNOB, bar: molded black bakelite; for 1/4" diam shaft; single #8-32 setscrew; 1 1/4" lg x 1/2" wd x 5/8" d over-all; Natl Co type #SA:7 (control for phasing).
	2Z5824.20	KNOB, bar: molded black bakelite; for 1/4" shaft; single #8-32 setscrew; 1 1/4" lg x 1/2" wd x 5/8" d over-all; Natl Co #SA:5 (control for RF gain).
	2Z5824.2	KNOB, bar: black phenolic; for 1/4" diam shaft; single Allen setscrew; 1 1/4" x 1/8" x 5/8" over-all; Natl Co #HR-P (selectivity).
	2Z5925	LAMP LM-25: incandescent; 6.3 v, 0.15 amp, bulb T-3-1/4" clear; miniature screw lamp; Mazda #40 (meter pilot lamp).
	2Z5952	LAMP LM-52: incandescent; 6-8 v, 0.15 amp, bulb T3-1/4"; miniature bayonet base; Mazda #47 (on-off pilot lamp).
	2Z5883-92	LAMPHOLDER: miniature bayonet base; pressed steel body; 1 5/8" x 1 1/2" x 1 1/2" over-all; Mallory #B-310-RX (for on-off pilot lamp).
	3F3299	METER, milliammeter: dc; 0-1 ma; round bakelite flush mtg; 2 1/2" flange; 2 1/4" mtg hole; 2 1/2" d; Natl Co type #SM-80 (transparent scale; first half 0-9 in S units; 2nd half 0-40 DB units above S9; hole with 1/4" rubber grommet in rear of meter for pilot lamp).
R4, 27, 29	3RC20BE301J	RESISTOR, fixed: composition; 300 ohms ±5%; 1/2 w; RC20BE301J.
R25	3RC41BE511J	RESISTOR, fixed: composition; 510 ohms ±5%; 1/2 w; RC41BE511J.
R20	3RC20BE821J	RESISTOR, fixed: composition; 820 ohms ±5%; 1/2 w; RC21BE821J.
R2, 9	3RC20BE512J	RESISTOR, fixed: composition; 5,100 ohms ±5%; 1/2 w; RC20BE512J.
R10	3RC41BE153K	RESISTOR, fixed: composition; 15,000 ohms ±10%; 2 w; RC41BE153K.
R16, 35	3RC20BE203J	RESISTOR, fixed: composition; 20,000 ohms ±5%; 1/2 w; 3RC20BE203J.
R15	3RC41BE303J	RESISTOR, fixed: composition; 30,000 ohms ±5%; 2 w; RC41BE303J.
R5, 13, 34	3RC20BE513J	RESISTOR, fixed: composition; 51,000 ohms ±5%; 1/2 w; RC20BE513J.
R6, 7, 23, 24	3RC20BE104K	RESISTOR, fixed: composition; 100,000 ohms ±10%; 1/2 w; RC20BE-104K.
R17, 18	3RC41BE104K	RESISTOR, fixed: composition; 100,000 ohms ±10%; 2 w; RC41BE-104K.
R14, 22	3RC20BE244J	RESISTOR, fixed: composition; 240,000 ohms ±5%; 1/2 w; RC20BE-244J.
R3, 8, 12, 19, 26, 28, 31	3RC20BE514J	RESISTOR, fixed: composition; 510,000 ohms ±5%; 1/2 w; RC20BE-514J.
R21	3Z60006D4	RESISTOR, fixed: wire-wound; 64 ohms ±10%; 3 w; 1 3/8" lg, wound on flat strip; Mallory type #864-C.
R32	2Z7279-22	RESISTOR, variable (potentiometer): wire-wound; 1,000 ohms; 1 w; 1 3/8" diam x 1/4" d; 1/4" shaft 3/8" beyond bushing; Clarostat #E-9029A type MH.
R1	2Z7280-28	RESISTOR, variable (potentiometer): wire-wound; 10,000 ohms; 1.5 w; 1 3/8" diam x 1 1/8" d; Clarostat #G-60, type P-58.
R33	2Z7272-23	RESISTOR, variable (potentiometer): carbon; 500,000 ohms ±20%; 2 w; 1 3/8" diam x 1 1/8" d; Centralab #1-010-1635.
	2ZK8309-1	SHIELD, tube: aluminum; round; ventilating holes; friction mtd; 4 1/4" lg x 1 5/8" in diam; Natl Co #T78.
	2Z8676.58	SOCKET, tube: 6 prong; bakelite; 2 1/2" lg x 1 1/2" thk; Cinch #Z-18.
	2Z8676.59	SOCKET, tube: 6 prong; ceramic; 1 3/8" diam; Natl Co #CIR-6.
X2	3Z9858-8.31	SWITCH, toggle: SPST; 7/8" lg x 1/4" wd x 1 1/8" d; AH&H #20994L.
X3	3Z9858-8.32	SWITCH, toggle: SPDT; 1 1/4" lg x 1 1/2" wd x 1 1/8" d; AH&H #21350E.

Reference symbol	Signal Corps stock No.	Name and part of description
X1, 4 T4	3Z9858-8.33 2Z9644.10	SWITCH, toggle: SPST; $\frac{3}{8}$ " lg x $\frac{1}{2}$ " wd x $\frac{1}{8}$ " d; AH&H type #80994. TRANSFORMER, BFO: 456 kc; $4\frac{3}{16}$ " lg x $2\frac{3}{8}$ " wd x $1\frac{1}{2}$ " thk; Natl Co type SA: 41H.
T3	2Z9641.81	TRANSFORMER, IF: 456 kc; output; shielded; $4\frac{3}{16}$ " lg x $2\frac{3}{8}$ " wd x $1\frac{1}{2}$ " thk; Natl Co type #SA-41-G.
T2	2Z9641.82	TRANSFORMER, IF: 456 kc; interstage; shielded; $4\frac{3}{16}$ " lg x $2\frac{3}{8}$ " wd x $1\frac{1}{2}$ " thk; Natl Co #SA-41-F.
	3C2625-1	TUNING UNIT, RF: ant; RF and osc coils; 100-200 kc; $10\frac{1}{2}$ " wd x $2\frac{1}{8}$ " h x $5\frac{3}{8}$ " d over-all; Natl Co type H.
	3C2625	TUNING UNIT, RF: ant, RF and osc coils; 50-100 kc; $10\frac{1}{2}$ " wd x $2\frac{1}{8}$ " h x $5\frac{3}{8}$ " d over-all; Natl Co type J.
	3C2625-2	TUNING UNIT, RF: ant, RF and osc coils; 180-430 kc; $10\frac{1}{2}$ " wd x $2\frac{1}{8}$ " h x $5\frac{3}{8}$ " d over-all; Natl Co type G.
	3C2625-3	TUNING UNIT, RF: ant, RF and osc coils; 480-960 kc; $10\frac{1}{2}$ " wd x $2\frac{1}{8}$ " h x $5\frac{3}{8}$ " d over-all; Natl Co type F.
	3C2625-4	TUNING UNIT, RF: ant, RF and osc coils; 900-2050 kc; $10\frac{1}{2}$ " wd x $2\frac{1}{8}$ " h x $5\frac{3}{8}$ " d over-all; Natl Co type E.
	3C2625-5	TUNING UNIT, RF: ant, RF and osc coils; 1.7-4.00 mc; $10\frac{1}{2}$ " wd x $2\frac{1}{8}$ " h x $5\frac{3}{8}$ " d over-all; Natl Co type JD.
	3C2625-7	TUNING UNIT, RF: ant, RF and osc coils; 3.5-7.3 mc; $10\frac{1}{2}$ " wd x $2\frac{1}{8}$ " h x $5\frac{3}{8}$ " d over-all; Natl Co type JC.
	3C2625-6	TUNING UNIT, RF: ant, RF and osc coils; 7.0-14.4 mc; $10\frac{1}{2}$ " wd x $2\frac{1}{8}$ " h x $5\frac{3}{8}$ " d over-all; Natl Co type JB.
	3C2625-8	TUNING UNIT, RF: ant, RF and osc coils; 14.0-30.0 mc; $10\frac{1}{2}$ " wd x $2\frac{1}{8}$ " h x $5\frac{3}{8}$ " d over-all; Natl Co type JA.
V7	2J6B7	TUBE, electron: JAN-6B7 (glass).
V7	2J6SQ7	TUBE, electron: JAN-6SQ7 (metal).
V3, 4, 8	2J6C6	TUBE, electron: JAN-6C6 (glass).
V3, 4, 8	2J6J7	TUBE, electron: JAN-6J7 (metal).
V1, 2, 5, 6,	2J6D6	TUBE, electron: JAN-6D6 (glass).
V1, 2, 5, 6,	2J6K7	TUBE, electron: JAN-6K7 (metal).
V9	2J42	TUBE, electron: JAN-42 (glass).
V9	2JV6GT/G	TUBE, electron: JAN-6V6GT/G (glass).
C12, 13, 14	3DB8-82.1	CAPACITOR, fixed: electrolytic; 3 sect; 8-8-8-mf; 475 vdcw; $3\frac{1}{8}$ " lg x 2" diam; Sprague #D-9053 or INNco #40B300.
	2Z2636-26	CLAMP: tube; stainless steel; natural finish; $2\frac{1}{8}$ " lg x $1\frac{1}{2}$ " wd x $\frac{3}{8}$ " h over-all; Birtcher #926C.
L-2	3C326-80	COIL, AF: filter; 17 hy; 80 ma; 300 ohms; $3\frac{5}{8}$ " h x $3\frac{5}{8}$ " lg x $3\frac{1}{2}$ " wd over-all; Natl Co #80.
P-1	6Z3156	CONNECTOR, male contact: 2 rectangular parallel cont; straight; $1\frac{1}{8}$ " diam x $1\frac{3}{10}$ " lg over-all; Corwire #150.
X-2, 3	2Z8674.40	SOCKET, tube: 4 prong; bakelite wafer; $2\frac{1}{2}$ " lg x $1\frac{1}{8}$ " diam; Cinch #X-18.
S-2	3Z9858-8.33	SWITCH, toggle: SPST; bakelite body; $\frac{3}{8}$ " lg x $\frac{1}{2}$ " wd x $\frac{1}{8}$ " d; AH&H #80994.
S-3	3Z9857.40	SWITCH, toggle: DPDT; bakelite body; $1\frac{1}{8}$ " lg x $\frac{5}{8}$ " wd over-all; AH&H #20905-GH.
T-1	2Z9608-7	TRANSFORMER, power: plate and fil; pri 115 and 230 v, 50/60 cyc; secd #1 560 v, 35 ma, CT; secd #2 5 v, 3 amp; secd #3 6.3 v, 3.4 amp; $3\frac{1}{8}$ " wd x $3\frac{1}{8}$ " wd x $3\frac{3}{4}$ " d x $3\frac{3}{4}$ " h; Natl Co #D-367.
V-2	2J80	TUBE, electron: JAN-80.

2. Maintenance Parts for Radio Receiver (National Model HRO-MX), Power Supply (National Type SPU 686-S), and Power Supply (National Type SPU 697)

The information below was compiled on 17 July 1945. The appropriate pamphlet of the

WD Signal Supply Catalog for Radio Receiver (National model HRO-MX) is—

Fixed plant maintenance list:

SIG 10-333, Radio Receiver HRO-M.

(For an index of available catalog pamphlets, see the latest issue of WD Signal Supply Catalog SIG 2.)

a. MAINTENANCE PARTS FOR RADIO RECEIVER (NATIONAL MODEL HRO-MX).

Reference symbol	Signal Corps stock No.	Name of part and description	Manufacturer's part and code No.
		RADIO RECEIVER HRO-MX: freq range, 50-430 kc and 480-30,000 kc includes: POWER UNIT 686-S, 6 v dc POWER UNIT 697, 115/230 v, 50-60 cps ac BRUSHBOARD: contacting plug-in coil sets CABLE ASSEMBLY: power, 5 ft lg	SA-22-G (N1) C-627 (N1)
C1, C3, C4, C5, C6, C10, C14, C17, C18, C20, C21, C22, C23, C25	2Z9405.45 3E4013-4		
C2, C7, C9, C15, C24, C26, C28	3DA100-129	CAPACITOR, paper: 0.1 mf, 400 vdcw	G (S8)
C8	3DA10-196	CAPACITOR, paper: 0.01 mf, 600 vdcw	G (S8)
C11, 19	3DA250-73	CAPACITOR, paper: 0.25 mf, 600 vdcw	G (S8)
C12, 30, 31, 32, 42	3DB10-47	CAPACITOR, electrolytic: 10 mf, 50 vdcw	FA10003 (C15)
C13	3K2010114	CAPACITOR, ceramic: 0.0001 mf, 500 vdcw	CM20A101M
C16	3K2024142	CAPACITOR, mica: 0.00024 mf, 500 vdcw	CM20D241J
C27	3K2051112	CAPACITOR, mica: 0.00051 mf, 500 vdcw	CM20A511J
C29	3D9035V-33	CAPACITOR, variable: 30 mmf, 6 plate	SA-13 (N1)
C33	3DA1-52	CAPACITOR, mica: 0.001 mf, 500 vdcw	1467 (A1)
C34	3D9002-12	CAPACITOR, mica: 0.000002 mf, 400 vdcw	SA-17 (N1)
C36	3D9040-18	CAPACITOR, ceramic: 0.00004 mf, 500 vdcw	D (C4)
C37	3D9850-2	CAPACITOR, mica: 850 mf, 500 vdcw	1467 (A1)
C38	3DA2.600	CAPACITOR, mica: 0.0026 mf, 500 vdcw	1467 (A1)
C39	3K3016233	CAPACITOR, mica: 0.0016 mf ±2%, 500 vdcw	CM3CC162G
C40	3D9880-2	CAPACITOR, mica: 0.00088 mf, 500 vdcw	1467 (A1)
C41	3D9450-3	CAPACITOR, ceramic: 0.00045 mf, 500 vdcw	DUAL C (C4)
C43	3D9350-14	CAPACITOR, ceramic: 0.00035 mf, 500 vdcw	DUAL C (C4)
C46	D9050-107	CAPACITOR, ceramic: 0.00005 mf, 500 vdcw	D (C4)
	3D9225V-7	CAPACITOR, variable: main tuning, 4 sect, 12 to 225 mmf ea sect	SA-14-B (N1)
	3C2625	COIL ASSEMBLY, RF: ant, r-f and osc coils, 50-100 kc, consists of 4 coils	J (N1)
	3C2625-1	COIL ASSEMBLY, RF: ant, and osc coils, 100-200 kc, consists of 4 coils	H (N1)
	3C2625-2	COIL ASSEMBLY, RF: ant, r-f and osc coils, 180-430 kc, consists of 4 coils	G (N1)
	3C2625-3	COIL ASSEMBLY, RF: ant, r-f and osc coils, 480-960 kc, consists of 4 coils.	F (N1)
	3C2625-4	COIL ASSEMBLY, RF: ant, r-f and osc, coils, 900-2050 kc, consists of 4 coils	E (N1)
	3C2625-5	COIL ASSEMBLY, RF: ant, r-f and osc coils, 1.7-4 mc, consists of 4 coils	JD (N1)
	3C2625-7	COIL ASSEMBLY, RF: ant, r-f and osc coils, 3.5-7.3 mc, consists of 4 coils	JC (N1)

Ref symbol	Signal Corps stock No.	Name of part and description	Manufacturer's part and code No.
	3C2625-6	COIL ASSEMBLY, RF: ant, r-f and osc coils, 7.0-14.4 mc, consists of 4 coils	JB (N1)
	3C2625-8	COIL ASSEMBLY, RF: ant, r-f and osc coils, 14-30 mc, consists of 4 coils	JA (N1)
	2Z3764.26	DIAL ASSEMBLY, tuning: bakelite knob, w/dial	NPW, SA-645 (N1)
T1	3Z1891-19	FILTER, xtal, IF: 455 kc, w/xtal	SA-81 (N1)
	2Z5598-8	JACK, phone: two ckt	704-A (M1)
K1	2Z3764.26	KNOB, tuning: with micrometer dial	SA-645 (N1)
K2	2Z5840-15	KNOB, selectivity control: ¼" shaft	SA-1273 (N1)
K3	2Z5824.22	KNOB, phasing control: ¼" shaft	SA-7 (N1)
K4	2Z5824.20	KNOB, RF gain control: ¼" shaft	SA-5 (N1)
K5	2Z5824.21	KNOB, CWO control: ¼" diam shaft	SA-6 (N1)
K6	2Z5824.19	KNOB, audio gain: ¼" diam shaft	SA-4 (N1)
	2Z5952	LAMP, pilot: 6-8 v, 0.15 amp	47 (G3)
	2Z5883-58	LAMPHOLDER: pilot; minature bayonet base with red jewel	B-310-RX (M1)
	3F891-20	METER, DC: 0-1 ma	MR25W001 DCMA
R1	2Z7280-28	RESISTOR, pot: WW, 10,000 ohms, 1.5 w	G60, Type P-58 (C12)
R2, 9	3RC21BE512J	RESISTOR, carbon: 5,100 ohms, ½ w	RC20BE512J
R3, 8, 12, 19, 26, 28, 31	3RC21BE514J	RESISTOR, carbon: 510,000 ohms, ½ w	RC20BE514J
R4, 27, 29	3RC21BE301J	RESISTOR, carbon: 300 ohms, ½ w	RC20BE301J
R5, 13, 34	3RC21BE513J	RESISTOR, carbon: 51,000 ohms, ½ w	RC20BE513J
R6, 7, 22, 24	3RC21BE104K	RESISTOR, carbon: 100,000 ohms, ½ w	RC20BE104K
R10	3RC41BE153K	RESISTOR, carbon: 15,000 ohms, 2 w	RC41BE153K
R11	3RC21AE242J	RESISTOR, carbon: 2,500 ohms, ½ w	310 (C4)
R14, 23	3RC21BE244J	RESISTOR, carbon: 240,000 ohms, ½ w	RC20BE244J
R15	3RC41BE303J	RESISTOR, carbon: 30,000 ohms, 2 w	RC41BE303J
R16, 35	3RC21BE203J	RESISTOR, carbon: 20,000 ohms, ½ w	RC20BE203J
R17, 18	3RC41BE104K	RESISTOR, carbon: 100,000 ohms, 2 W	RC41BE104K
R20	3RC21BE821J	RESISTOR, carbon: 820 ohms, ½ w	RC20BE821J
R21	3Z6006D4	RESISTOR, WW: 64 ohms, 3 w	864-C (M1)
R25	3RC41BE511J	RESISTOR, carbon: 510 ohms, 2 ww	RC41BE511J
R30	3RC21BE202J	RESISTOR, carbon: 2,000 ohms, ½ w	RC21BE202K
R32	2Z7279-22	RESISTOR, pot: WW, 1,000 ohms, 1 w	E-9029A type MH (C10)
R33	2Z7272-23	RESISTOR, pot: carbon, 500,000 ohms, 2 w	1-010-1635 (C4)
	2Z8676.59	SOCKET, tube: 6 cont, ceramic	CIR-6 (N1)
	2Z8676.58	SOCKET, tube: 6 cont, bakelite	Z18 (C6)
	2Z8677.39	SOCKET, tube: 7 prong, ceramic	CIR-7S (N1)
	6C35-14	SPEAKER, dynamic: 8" includes audio output transformer, Jensen #Z1642	PM8C (J6)
X1, 4	3Z9858-8.33	SWITCH, toggle: SPST, (same as in 6 v and 115 v power unit)	80994 (A17)
X2	3Z9858-8.31	SWITCH, toggle: SPST	20994L (A17)
X3	3Z9858-8.32	SWITCH, toggle: SPDT	21350E (A17)
	2Z9402.98	TERMINAL BOARD: 2 term, ant	FWK-SA21 (N1)
	2Z9402.1	TERMINAL BOARD: 2 pin type jacks, marked SPKR	1490 (C6)
T2	2Z9641.82	TRANSFORMER ASSEMBLY: 2d IF, 456 kc, includes 2 trimmers	SA-41-F (N1)
T3	2Z9641.81	TRANSFORMER ASSEMBLY, IF: 456 kc, includes 2 trimmers	SA-41-G (N1)

Ref symbol	Signal Corps stock No.	Name of part and description	Manufacturer's part and code No.
T4	2Z9644.10	TRANSFORMER ASSEMBLY, BFO: 456 kc, includes trimmer	SA-41-H (N1)
V1, 2, 5, 6	2J6D6	TUBE: type 6D6	6D6
V3, 4, 8	2J6C6	TUBE: type JAN-6C6	JAN6C6
V7	2J6B7	TUBE: type JAN-6B7	JAN7B7
V9	2J42	TUBE: type JAN-42	JAN42

b. MAINTENANCE PARTS FOR POWER SUPPLY (NATIONAL TYPE SPU-S).

E2, 3	3Z1086B-1	BATTERY CLIP	24A (M31)
C1	3DB500-13	CAPACITOR, electrolytic: 500 mf, 15 vdcw	BRH-155 (C15)
C2, 3	3DB8-82	CAPACITOR, electrolytic: dual, 8-8 mf, 475 vdcw	D-9052E (S8)
L1	3C326-31B	COIL, choke: filter, 17 h	SA-31-B (N1)
L2	3C326-869	COIL: hash choke	SA-869 (N1)
F1	3Z1921	FUSE: 10 amp, 25 v, type 3AG	1081 (L3)
X2	3Z3275	FUSE EXTRACTOR POST	1075 (L3)
X1	2Z8674.40	SOCKET, tube: 4 cont, bakelite, wafer	X-18 (C6)
S1	3Z9858-8.33	SWITCH, toggle: SPST (same as X1, 4 in receiver)	80994 (A17)
E4	3H6785-1	VIBRAPACK: 6 v d-c input, 165 v dc @ 50 ma output, includes:	6B200 (M1)
	3DA500-38	CAPACITOR, paper: 0.5 mf, 50 vdcw	RF481 (M1)
	3DA6-98	CAPACITOR, paper: 0.006 mf, 1500 vdcw	CP26A1EH602K
	3DA100-604	CAPACITOR, paper: 0.1 mf, 200 vdcw	CP26A1EC104K
	3DA50-239	CAPACITOR, paper: 0.05 mf, 600 vdcw	CP26A1EF503K
	3C337-7	COIL, RF choke: 1 mh, 15 ohm	A-42334-2 (M1)
	3C323-12H	COIL, hash choke: 55 turns #16 wire	A-40785-2 (M1)
	3RC21BE512J	RESISTOR, carbon: 5,100 ohm, 1/2 w	RC21BE512J
	2Z9625-49	Transformer, vibrator, 3 v input, output 200 v at 40 ma	B-44678-4 (M1)
	2J6X5GT/G	TUBE: type JAN-6X5GT/G	JAN6X5GT/G
	2C4903A/V1	VIBRATOR, plug-in: 4 prong	826 (M1)

c. MAINTENANCE PARTS FOR POWER SUPPLY (NATIONAL TYPE SPU 697).

C12, 13, 14	3DB8-177	CAPACITOR, electrolytic: 3 sect, 8-8-8-mf, 475 vdcw	D7166 (S8)
L2	3C326-31Q	COIL, AF filter: 17 h @ 80 ma, 300 ohm	SA-31Q (N1)
X2, 3	2Z8674.40	SOCKET, tube: 4 cont, bakelite wafer	X-18 (C6)
S2	3Z9858-8.33	SWITCH, toggle: SPST (same as in X1, 4 receiver)	80994 (A17)
S3	3Z9858-3.2	SWITCH, toggle: DPDT	81012AB (A17)
T1	2Z9608-7	TRANSFORMER, power: pri 115 v and 230 v 50/60 cps, secd #1, 560 v ct @ 35 ma, secd #2, 5 v @ 3 amp, secd #3, 6.3 v @ 3.4 amp	
V2	2J80	TUBE: type JAN-80	JAN80

3. List of Manufacturers

<i>Code No.</i>	<i>Name</i>
A1	Aerovox Corporation.
A17	Arrow, Hart & Hegeman Electric Co.
C6	Cinch Mfg. Corp.
C10	Clarostat Mfg. Co., Inc.
C12	Codeco-Communications Development Co.
C15	Cornell-Dubilier Electric Corp.
G3	General Electric Co.
G15	Globe Union, Inc.
J6	Jensen Radio Mfg. Co.
L3	Littlefuse, Inc.
M1	Mallory, P. R., & Co.
M31	Mueller Electric Co.
N1	National Co.
S8	Sprague Specialties Co.

U. S. GOVERNMENT PRINTING OFFICE: 1947—74

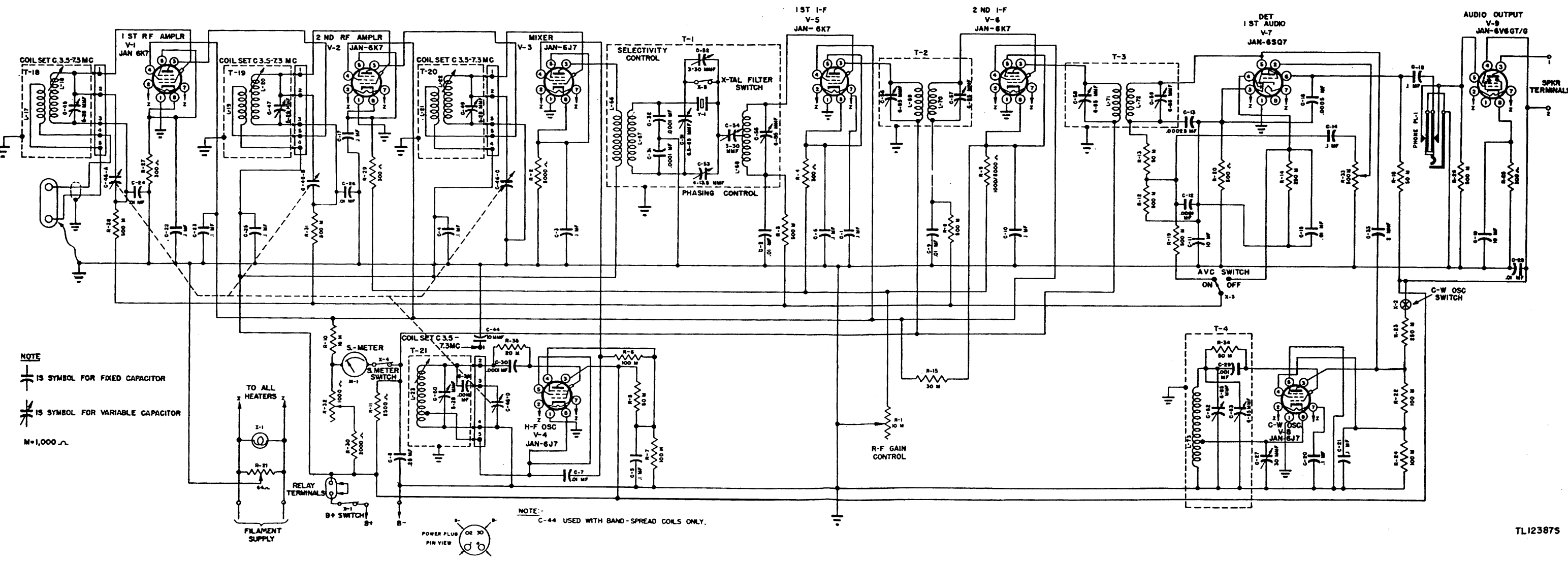

Figure 36. Radio Receiver R-140/FSM-1 (with metal tubes) and National HRO-5 series

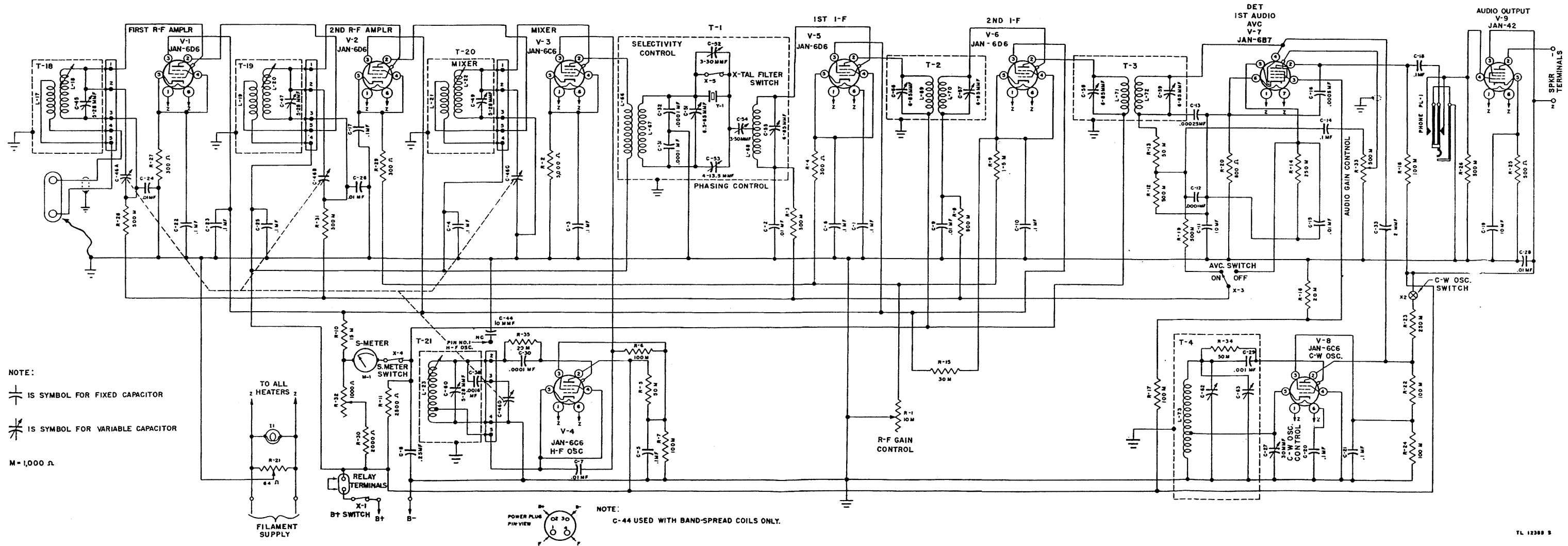

Figure 37. Radio Receiver R-140/FSM (with glass tubes) and National HRO-M series receivers - schematic wiring diagram