

RESTRICTED

2585.7 - 6000  
3654.7 - 9500

**INSTRUCTION BOOK**  
**FOR**  
**RADIO STATION**  
**RS-6**

RESTRICTED

## TABLE OF CONTENTS

	Paragraph	Page
<b>CHAPTER 1. INTRODUCTION</b>		
Section I. General		
Scope .....	1	1
Description .....	2	1
II. Technical Characteristics		
Transmitter RT-6 .....	3	1
Receiver RR-6 .....	4	1
Power Supply RP-6 .....	5	1
Filter-Accessory Unit RA-6 .....	6	1
Additional Accessories .....	7	3
 <b>CHAPTER 2. OPERATING INSTRUCTIONS</b>		
Section I. Setting up Equipment		
AC operation hook-up .....	8	4
Battery operation hook-up .....	9	4
Hand generator operation hook-up .....	10	6
Battery charging hook-up and operation .....	11	6
II. Transmitter RT-6		
Controls and functions .....	12	8
Crystal selection .....	13	8
Antenna length and height .....	14	9
Ground connection .....	15	9
Tuning .....	16	9
Keying .....	17	10
III. Receiver RR-6		
Controls and functions .....	18	11
Calibrating the tuning dial .....	19	11
Tuning (variable) .....	20	11
Tuning (crystal) .....	21	12
Log scale .....	22	12
 <b>CHAPTER 3. MAINTENANCE</b>		
Section I. Receiver RR-6		
Circuit description .....	23	13
Corrective maintenance of Receiver .....	24	13
BFO Panel Removal .....	25	17
Alignment .....	26	17
Dial scale mechanism—Disassembly and reassembly .....	27	23
II. Transmitter RT-6		
Circuit description .....	28	24
Corrective maintenance of Transmitter .....	29	26
Sending key adjustment .....	30	26

	Paragraph	Page
III. Power Supply RP-6		
Circuit description .....	31	27
How to replace vibrator .....	32	28
How to replace power transformer .....	33	28
Corrective maintenance of Power Supply .....	34	28
IV. Filter-Accessory Unit RA-6		
Circuit description .....	35	29
How to disassemble .....	36	29
Corrective maintenance of Filter Unit .....	37	30
V. Packaging		
Units in plastic pouch .....	38	32
Units in cloth bag .....	39	32
<b>CHAPTER 4. REPLACEMENT PARTS LISTS</b>		
Section I. Receiver RR-6 .....		33
II. Transmitter RT-6 .....		38
III. Power Supply RP-6 .....		40
IV. Filter-Accessory Unit RA-6 .....		41
V. Additional Accessories .....		42
<b>APPENDIX I. LOW RANGE OHMMETER</b> .....		43

## LIST OF ILLUSTRATIONS

FIGURE	TITLE	PAGE
1	Radio Station RS-6 Components.....	VI
2	Filter-Accessory Unit RA-6 Opened, Showing Accessories.....	2
3	Additional Accessories.....	2
4	Power Supply RP-6 Showing Control Switch and Power Plug.....	4
5	Radio Station RS-6 A-C Operation Hook-Up.....	5
6	Radio Station RS-6 Battery Operation Hook-Up.....	5
7	Radio Station RS-6 Hand Generator Operation Hook-Up.....	6
8	Radio Station RS-6 Battery Charging Hook-Up.....	7
9	Transmitter RT-6 Showing Control Locations.....	8
10	Filter-Accessory Unit RA-6 Showing RECVR-TRANS Switch.....	9
11	Receiver RR-6 Showing Control Locations.....	10
12	Receiver RR-6 Schematic Diagram.....	14
13	Point-to-Point Resistance Measurement on Rangeswitch.....	18
14	Receiver RR-6 Top & Bottom View Showing Alignment Adjustment Locations.....	18
15	Receiver RR-6 Showing Panel Assembly Parts Locations.....	20-21
16	Receiver RR-6 Top View Showing Parts Locations.....	22
17	Disassembly of Receiver RR-6 Dial Mechanism.....	22
18	Transmitter RT-6 Schematic Diagram.....	24
19	Transmitter RT-6 Parts Locations.....	25
20	Power Supply RP-6 Schematic Diagram.....	27
21	Power Supply RP-6 Vibrator Replacement.....	28
22	Power Supply RP-6 Parts Location.....	28
23	Filter-Accessory Unit RA-6 Schematic Diagram.....	31
24	Filter-Accessory Unit RA-6 Parts Location.....	31
25	Packaging Detail.....	32
26	Low Range Ohmmeter.....	43



**TRANSMITTER RT-6**

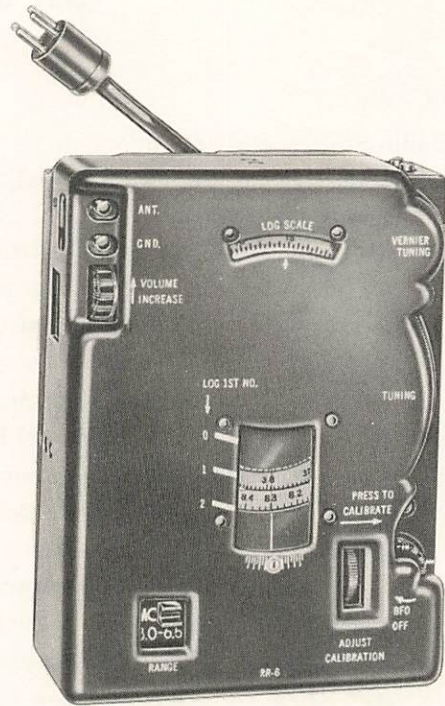

**RECEIVER RR-6**



**POWER SUPPLY RP-6**



**FILTER-ACCESSORY UNIT RA-6**

*Figure 1. Radio Station RS-6 Components.*

# CHAPTER 1 INTRODUCTION

## SECTION I. GENERAL

### 1. SCOPE

This instruction book contains a description, the theory of operation, and instructions for maintenance and repair of Radio Station RS-6.

for transmitting CW and receiving CW or AM. It operates from a-c, storage battery, or hand generator, and consists of a Transmitter RT-6, Receiver RR-6, Power Supply RP-6, and a Filter-Accessory Unit RA-6, as shown in Figure 1.

### 2. DESCRIPTION

Radio Station RS-6 is a compact four-unit set

## SECTION II. TECHNICAL CHARACTERISTICS

### 3. TRANSMITTER RT-6

- a. Type: 2-stage, crystal-controlled
- b. Frequency range (two bands):
  - (1) 3 to 7 mc (megacycles)
  - (2) 7 to 16.5 mc
- c. Power Output:  
6-10 watts (depending upon frequency)
- d. Power Input:
  - (1) Transmitting: 400-v dc at 75 ma (milliamperes). Idling during break-in: 400-v dc at 25 ma
  - (2) 6.3-v ac-dc at 1.2 amp (amperes)
- e. Weight: 2 lb 14 oz
- f. Dimensions (inches):  $6\frac{3}{4} \times 5 \times 2\frac{3}{32}$

### 4. RECEIVER RR-6

- a. Type: Superheterodyne, variable tuning or crystal-controlled, fixed frequency
- b. Frequency range (two bands):
  - (1) 3 to 6.5 mc
  - (2) 6.5 to 15 mc
- c. Power Input:
  - (1) 90-v dc at 15 ma regulated
  - (2) 90-v dc at 10 ma regulated
  - (3) 6.3-v ac-dc at 1.2 amp
- d. Weight: 3 lb 2 oz
- e. Dimensions (inches):  $6\frac{3}{4} \times 5 \times 2\frac{1}{4}$

### 5. POWER SUPPLY RP-6

- a. Power Source: a-c line or 6-volt storage battery
- b. Power Input:
  - (1) a-c 70 to 270 v, 40 to 400 cps (cycles per second), 80 watts nominal
  - (2) d-c 6.3-v at 12 amp
- c. Power Output:
  - (1) 6.3-v ac-dc at 2.4 amp
  - (2) 400-v dc at 75 ma
  - (3) 90-v dc at 25 ma regulated
  - (4) 90-v dc at 25 ma regulated
- d. Fuses:
  - (1) a-c—1.5 amp
  - (2) d-c—15 amp
- e. Power Factor:
  - (1) 40 cps—60
  - (2) 60 cps—86.7
  - (3) 400 cps—96.3
- f. Weight: 5 lb 11 oz
- g. Dimensions (inches):  $8\frac{1}{16} \times 4 \times 2\frac{3}{16}$

### 6. FILTER-ACCESSORY UNIT RA-6

- a. Function:
  - (1) Filters B+
  - (2) Regulates receiver B+
  - (3) Switches B+ to transmitter and to receiver

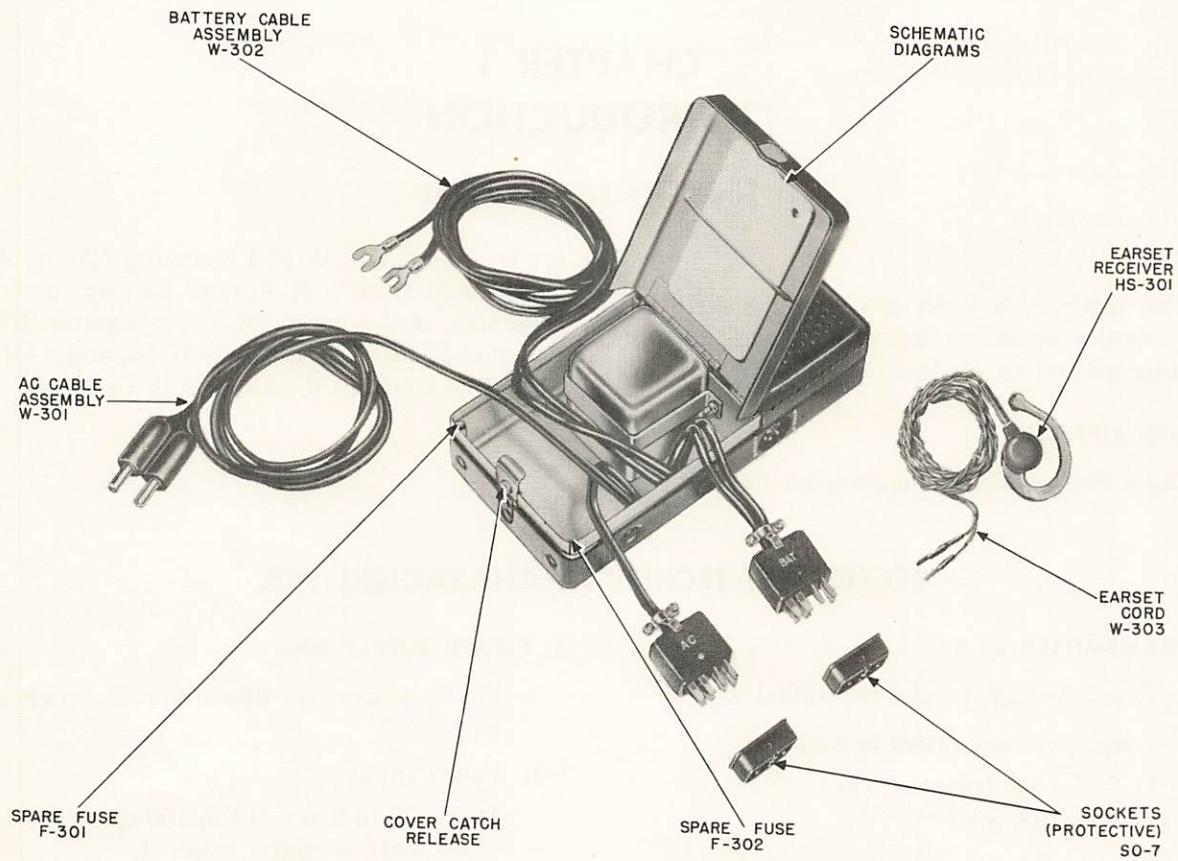

Figure 2. Filler-Accessory Unit RA-6 opened, showing accessories.

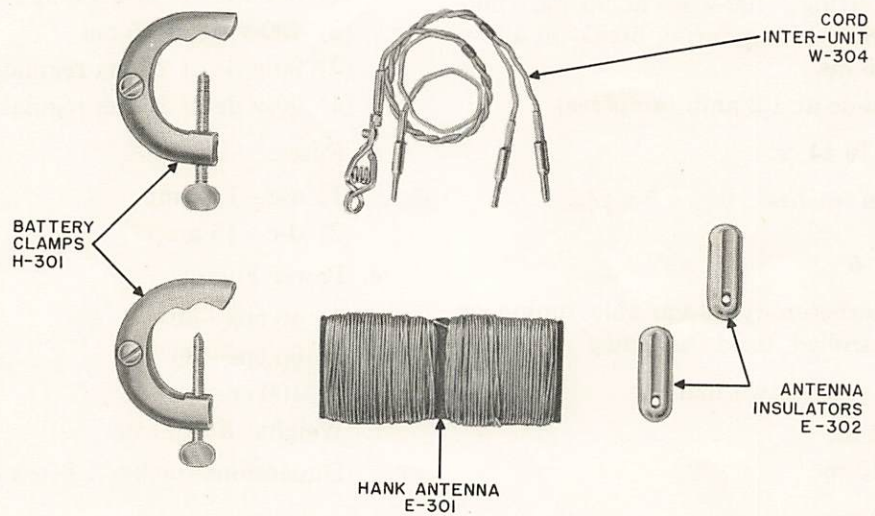

Figure 3. Additional Accessories.

(4) Provides storage space for accessories and power cables. See Figure 2.

b. Weight: 3 lb 11 oz

c. Dimensions (inches):  $8\frac{1}{16}$  x 4 x 2

d. Accessories:

- 1 A-C cable assembly
- 1 Battery cable assembly
- 1 Spare fuse—1.5 amp
- 1 Spare fuse—15 amp
- 1 Set Schematic Diagram Cards
- 1 Earset and cord

## 7. ADDITIONAL ACCESSORIES

The following accessories are contained in a plastic pouch (see Figure 3):

- 1 Hank antenna (100 ft)
- 2 Antenna insulators
- 2 Battery clamps
- 1 Inter-unit connecting cord with two leads to connect sidetone and antenna from transmitter to receiver
- 1 Incandescent lamp. Spare for E103

# CHAPTER 2

## OPERATING INSTRUCTIONS

### SECTION I. SETTING UP EQUIPMENT

#### 8. AC OPERATION HOOK-UP

a. Turn the input voltage selector switch on Power Supply RP-6 (Figure 4) to OFF.

b. Pull the sending key out of the recess on Transmitter RT-6.

c. Connect the equipment as shown in Figure 5. (Receiver crystal shown is optional.)

(1) The Jones plug marked AC must be inserted in the OPERATE receptacle on Power Supply RP-6 before the power plug is connected to an a-c power source, otherwise "hot" terminals will be exposed and a power line fuse may be blown.

(2) Connect the two-prong plug of the a-c cable assembly to any a-c power source whose voltage is between 70 and 270 volts, and frequency between 40 and 400 cycles per second. The two prong a-c power plug can be adapted to various receptacles in the following ways:

(a) Vary the spacing between the prongs by compressing plug.

(b) Prongs can be unscrewed and reversed to provide any combination of small and large prongs as required to fit various power outlets.

d. Turn the input voltage selector switch on Power Supply RP-6 clockwise to the first position at which the neon indicating light glows. The transmitter and receiver are now ready for operation.

e. Do not turn off the equipment by disconnecting the Jones plug marked AC. This would expose "hot" terminals. Turn off the equipment by pulling the power plug from the power source or by rotating the input voltage selector switch counterclockwise to the OFF position.

f. Refer to Sections II and III of this chapter for detailed transmitter and receiver operating instructions.

#### 9. BATTERY OPERATION HOOK-UP

a. Turn the input voltage selector switch on Power Supply RP-6 (Figure 4) to OFF.

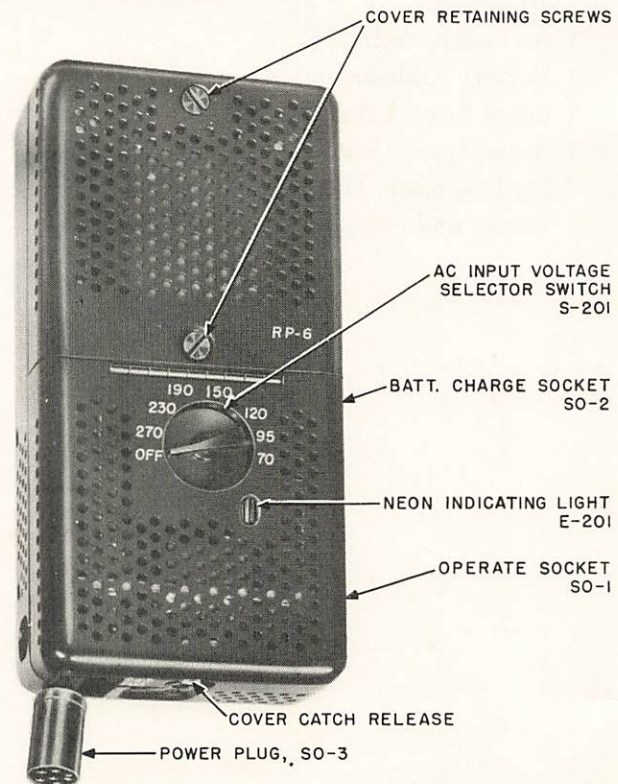

Figure 4. Power Supply RP-6 showing control switch and power plug.

b. Pull the sending key out of the recess on Transmitter RT-6.

c. Connect equipment as shown in Figure 6 (receiver crystal shown is optional).

(1) Use only a 6-volt storage battery source. If only an 8- or 12-volt storage battery is available, connect across only 6 volts (3 cells) of the battery. See Figure 6.

(2) The Jones plug marked BAT must be inserted in the OPERATE receptacle on Power Supply RP-6 before the battery clamps are connected to the storage battery, otherwise "hot" terminals will be exposed and equipment may be damaged.

(3) Connect the red battery lead to the positive 6-volt terminal of the battery, and the black battery lead to the negative terminal.

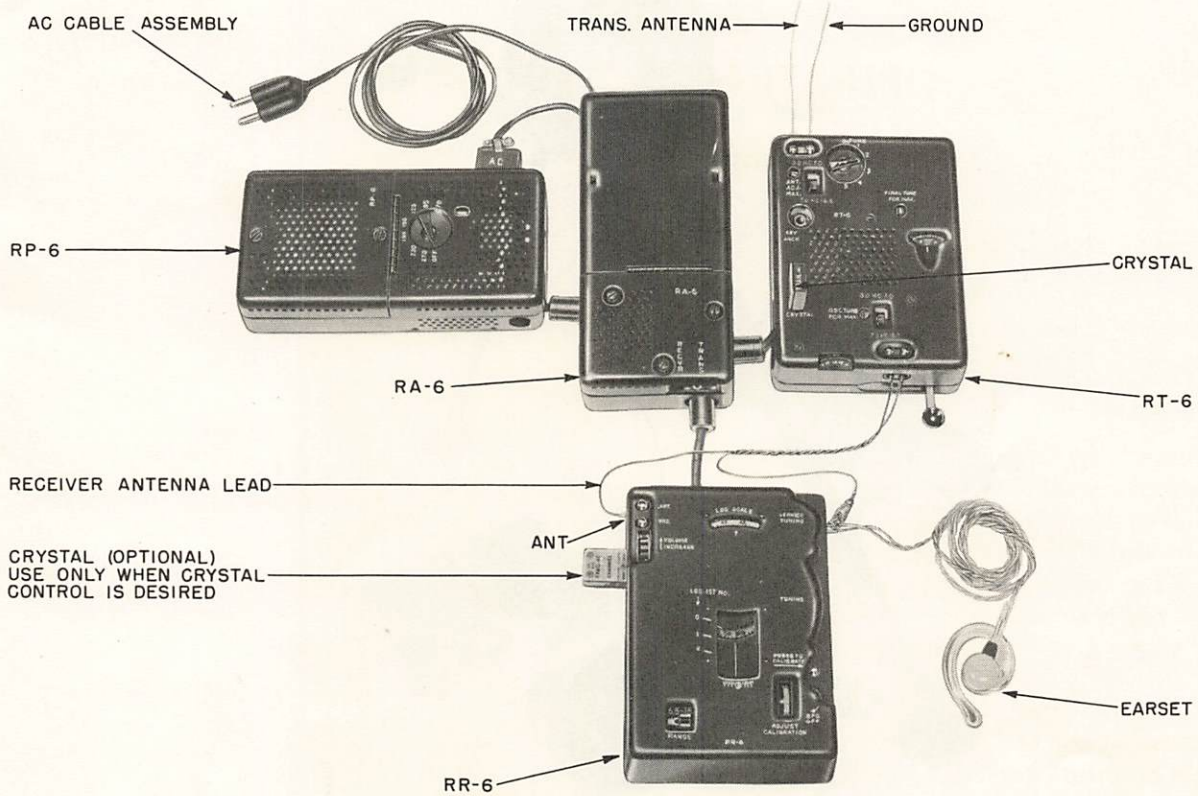

Figure 5. Radio Station RS-6, a-c operation hook-up.

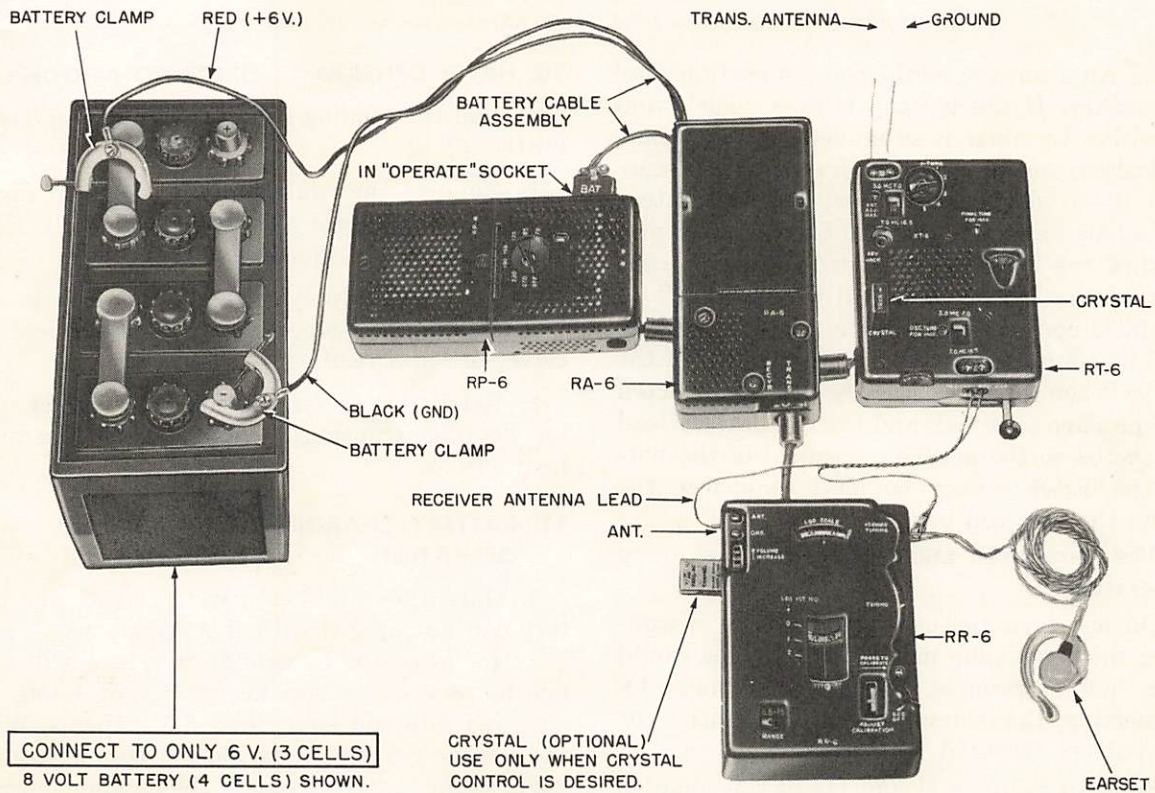

Figure 6. Radio Station RS-6, battery operation hook-up.

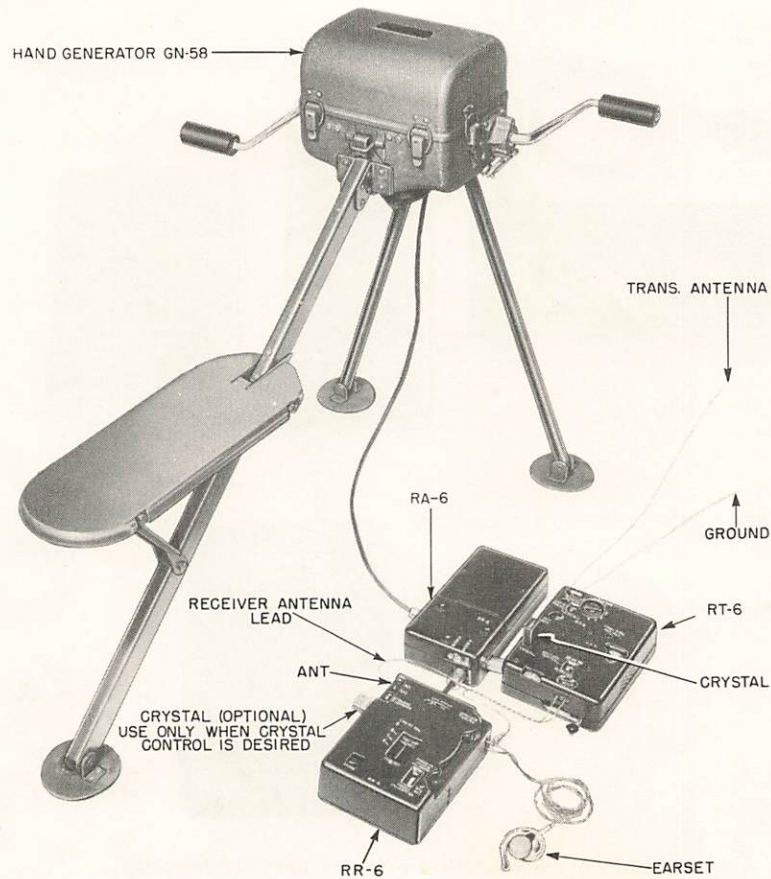

Figure 7. Radio Station RS-6, hand generator operation hook-up.

*NOTE:* An alternate method of connection may be necessary. If the battery is in a vehicle and its positive terminal is grounded to the frame, electrical contact between the frame and the case of the RS-6 will cause a short, i.e., the battery will discharge and the lead will overheat. To prevent this, the black battery lead should be connected to the battery terminal that connects to the vehicle body frame, and the red battery lead should be connected to the "hot" terminal of the battery. When the black battery lead is connected to the positive terminal, and the red battery lead is connected to the negative terminal of the battery, the RS-6 cannot be used to charge the battery; the fuse will burn out.

d. The transmitter and receiver are now ready for operation.

e. Do not turn the equipment off by disconnecting the Jones plug marked BAT. This would expose "hot" terminals. Turn off equipment by disconnecting the clamp from the positive or "hot" battery terminal.

f. Refer to Sections II and III of this chapter for detailed transmitter and receiver operation.

## 10. HAND GENERATOR OPERATION HOOK-UP

a. Pull the sending key out of recess on Transmitter RT-6.

b. Connect the equipment as shown in Figure 7. (Receiver crystal shown is optional.) Hand Generator GN-58 should be used.

*NOTE:* Power Supply RP-6 is not used in this method of operation. The transmitter and receiver are now ready for operation.

c. Refer to Sections II and III of this chapter for detailed transmitter and receiver operating instructions.

## 11. BATTERY CHARGING HOOK-UP AND OPERATION

a. Only a 6-volt (3 cell) wet type storage battery can be charged with this apparatus.

(1) When the electrolyte in a lead-acid storage battery has a specific gravity of 1.180, the charging rate will be at least 3.5 amperes. When the specific gravity of the electrolyte increases to 1.280 as the battery charges, the charging current gradually drops .8 ampere.

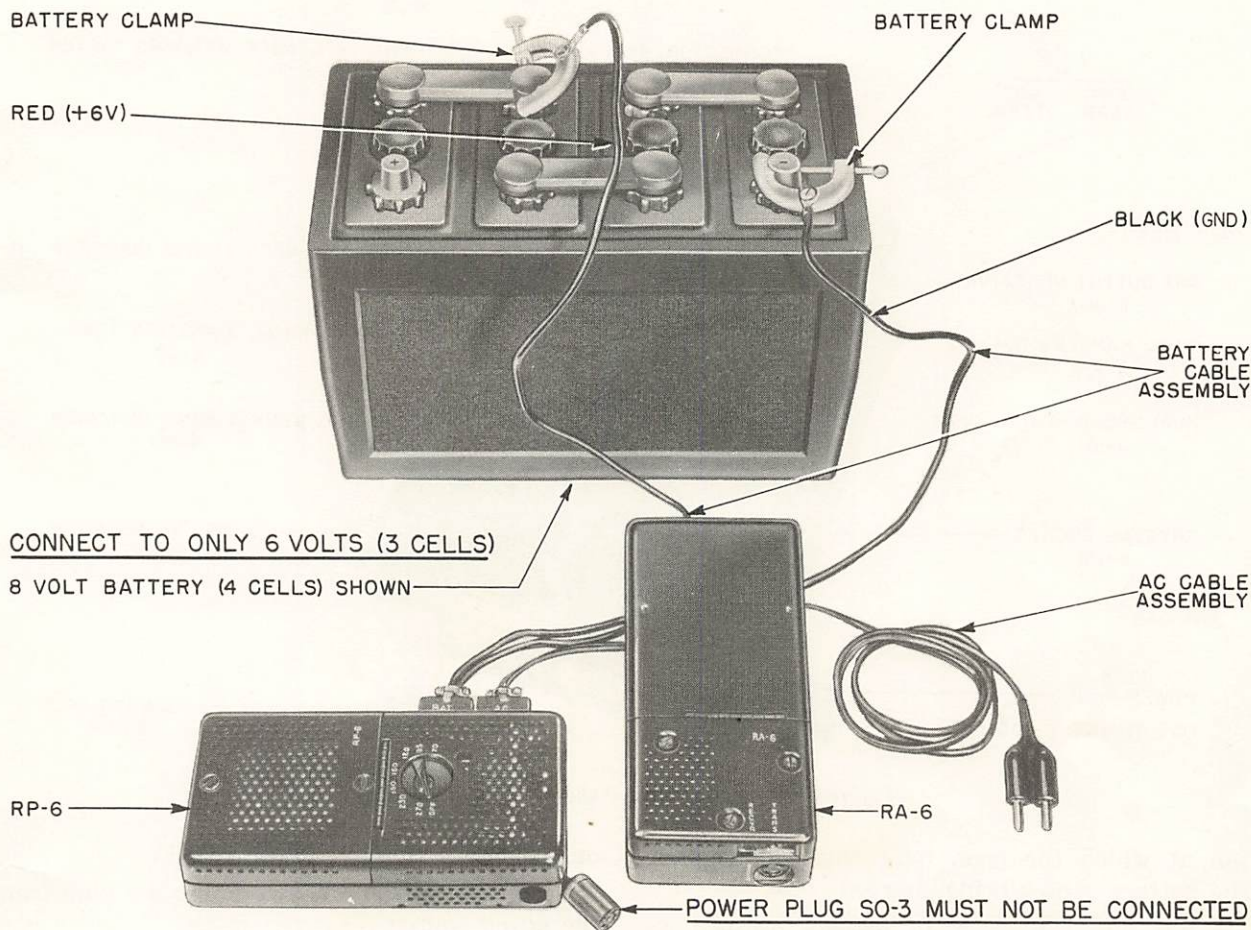

Figure 8. Radio Station RS-6 Battery Charging Hook-up.

(2) The battery should be charged only in a well ventilated room as dangerous gases are formed during the charging process.

b. It is desirable to keep the storage battery as fully charged as possible. The RP-6, when connected as a charger, should be used approximately 5 times as long as that period of time that the RS-6 was operating from the battery power source. A hydrometer is recommended to accurately determine the charge of the battery.

c. Connect the equipment as follows: (See Figure 8).

(1) Turn the input voltage selector switch on Power Supply RP-6 to OFF. (Figure 4)

(2) Disconnect Power Supply RP-6 power plug from the Filter-Accessory Unit, RA-6, if it is not already disconnected. This plug must be disconnected to avoid blowing the fuse.

(3) Insert the Jones plug marked BAT in the receptacle marked BATT-CHARGE.

(4) Connect the red battery lead to the positive 6-volt terminal of the storage battery.

(5) Connect the black battery lead to the negative terminal of the storage battery.

(6) Insert the Jones plug marked AC in the receptacle marked OPERATE.

(7) Connect the two-prong plug of the AC cable assembly to any a-c power source whose voltage is between 70 and 270 volts, and frequency between 40 and 400 cps. The two-prong a-c power plug can be adapted to various receptacles in the following ways:

(a) The spacing between the prongs can be varied by compressing the plug.

(b) The prongs can be unscrewed and reversed to provide any combination of small and large prongs as required to fit various power outlets.

d. Turn the input voltage selector switch of Power Supply RP-6 clockwise to the first posi-

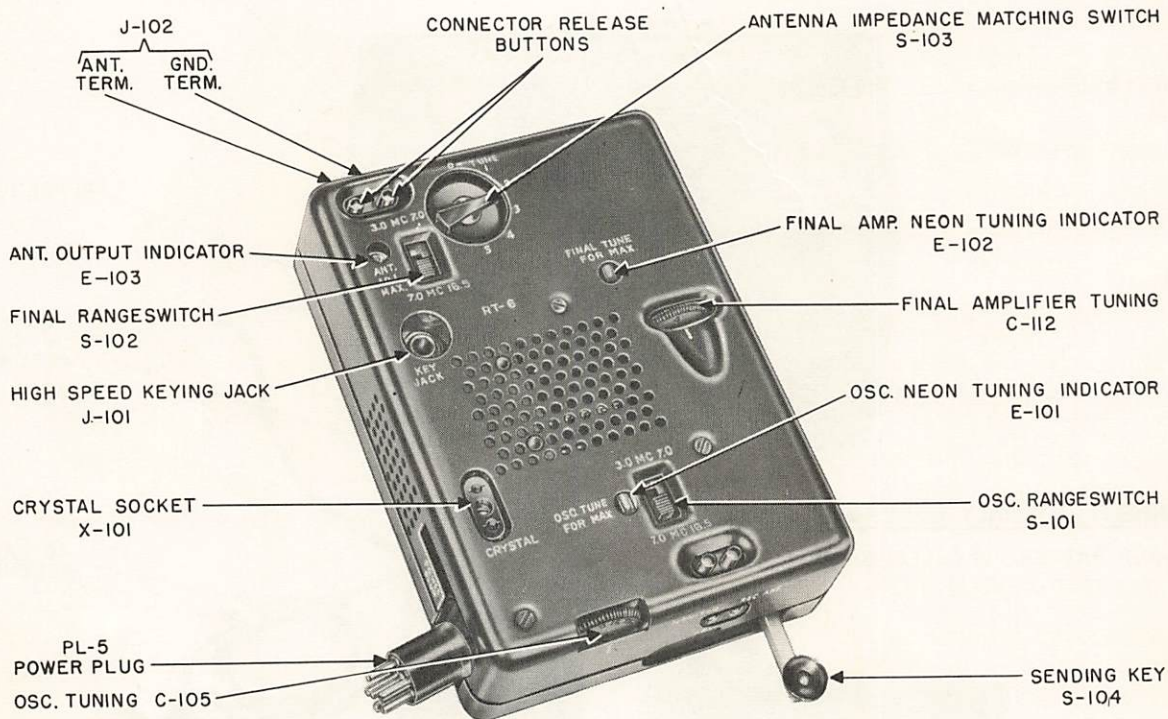

Figure 9. Transmitter RT-6 showing control locations

tion at which the neon indicating light glows. The battery is now being charged.

e. To stop the charging process proceed as follows:

- (1) Turn the input voltage selector switch

on the Power Supply RP-6 to OFF.

- (2) Disconnect the two-prong a-c plug from the power source.

- (3) Remove the battery leads from the battery.

## SECTION II. TRANSMITTER RT-6

### 12. CONTROLS AND FUNCTIONS—(See Figure 9)

a. OSCILLATOR RANGESWITCH—Selects the desired band for the oscillator.

- (1) Blue position—3 to 7 mc
- (2) Red position—7 to 16.5 mc

b. FINAL RANGESWITCH—Selects the desired band for the final amplifier.

- (1) Blue position—3 to 7 mc
- (2) Red position—7 to 16.5 mc

c. OSCILLATOR TUNING—Tunes the oscillator tank to the desired frequency.

- (1) Blue scale—3 to 7 mc
- (2) Red scale—7 to 16.5 mc

d. FINAL AMPLIFIER TUNING—Tunes the final amplifier plate tank to the desired frequency.

- (1) Blue scale—3 to 7 mc

- (2) Red scale—7 to 16.5 mc

e. ANTENNA IMPEDANCE MATCHING SWITCH—Matches the output impedance of the final amplifier to the antenna impedance.

f. SENDING KEY—Used for hand-keying the transmitter and for controlling the operation of the transmitter with other methods of keying.

### 13. CRYSTAL SELECTION

a. Any desired frequency within the range of the transmitter (3 to 16.5 mc) can be obtained by selecting an appropriate crystal within the range of 3 to 7 mc. This is accomplished by using the fundamental (the frequency stamped on the crystal), the second harmonic (two times funda-

mental), or the third harmonic (three times fundamental) of the crystals.

b. **DO NOT** use overmode crystals, nor operate crystals on fourth or higher harmonics.

#### 14. ANTENNA LENGTH AND HEIGHT

a. The length of the quarter wave "L" antenna for a given frequency can be calculated from the following formulas:

$$L \text{ (feet)} = \frac{234}{\text{freq (megacycles)}}$$

$$L \text{ (meters)} = 0.238 \times \text{wavelength}$$

b. The antenna should be as high as possible.

c. Connect the color coded lead of the short twisted cord to the REC ANT post on the transmitter and to the ANT TERM on the receiver.

#### 15. GROUND CONNECTION

Connect the terminal marked GND to a metal member buried in moist earth (water pipe, gas pipe, or ground stake).

#### 16. TUNING — (Refer to Figure 9)

a. Plug a crystal into the socket marked CRYSTAL. Its fundamental operating frequency must be either:

- (1) The same as the desired transmitting frequency (fundamental operation),
- (2) One-half the desired transmitting frequency (2nd harmonic operation), or
- (3) One-third the desired transmitting frequency (3rd harmonic operation).

b. Set the oscillator and final rangeswitches to the desired band. Both switches must be set to the same color.

(1) The blue position covers frequencies from 3 to 7 mc.

(2) The red position covers frequencies from 7 to 16.5 mc.

c. Set the oscillator and final amp tuning dials as closely as possible to the desired transmitting frequency. The dials are calibrated in megacycles and both dials must be set to the same color scale. The blue scale covers the same frequencies as are covered by the blue position of the rangeswitch and the red scale covers the frequencies covered by the red position of the rangeswitch.

d. Set the RECVR-TRANS switch on the Filter-Accessory Unit RA-6 to TRANS. See



Figure 10. Filter-Accessory Unit RA-6 showing RECVR-TRANS switch.

Figure 10.

e. Turn the antenna impedance matching switch to TUNE (zero). This disconnects the antenna and reduces radiation to a minimum while tuning up the transmitter.

f. Press the sending key and retune the final amp tuning dial slightly to obtain a distinct increase in brilliance of the FINAL TUNE FOR MAX indicator. Release the key.

g. Press the sending key and retune the oscillator tuning dial slightly to obtain a distinct increase in brilliance of the OSC TUNE FOR MAX indicator. If a pronounced brilliance peak is not noted on the indicator (as may be the case when using the third harmonic of a crystal) re-peak the oscillator tuning dial for peak brilliance of the FINAL TUNE FOR MAX indicator. Release the key.

h. Press the sending key down and turn the antenna impedance matching switch to that position where the ANT ADJ MAX indicator glows brightest. Release the key.

i. Press the sending key down and retune the final amp tuning dial slightly for peak brilliance of the ANT ADJ MAX indicator. Release the key.

## 17. KEYING

a. The transmitter is keyed:

(1) by the attached sending key (Figure 9). A keying speed not exceeding 40 wpm (words per minute) may be attained.

(2) by inserting a semi-automatic (bug) key half-way into the KEY JACK (Figure 9) and leaving the attached sending key out. A keying speed not exceeding 40 wpm may be attained.

(3) by completely inserting an automatic tape keyer into the KEY JACK (Figure 9) and leaving the attached sending key out. A keying speed not exceeding 60 wpm may be attained.

b. Break-in operation is provided on the TRANS position of the RECVR-TRANS switch. When the attached sending key or the semi-automatic (bug) key is released, the receiver will operate. Automatic switching of the antenna from the transmitter to the receiver is accomplished by

the keying relay. The antenna signal is fed to the receiver through the color coded lead in the twisted cord connected between the ANT TERM on the receiver and to the REC ANT post on the transmitter. When the RECVR-TRANS switch is in the RECVR position, it is necessary to connect the antenna directly to the ANT TERM on the receiver.

c. Sidetone for monitoring the transmitted signal is fed to the earset by the twisted cord lead inserted in the MONITOR post on the transmitter and clipped to the upper phones connector pin.

d. The transmitter is transmitting when the attached sending key is folded into the recess on the front panel. Therefore, the attached sending key must be left out when using external keying.

e. Coding of the transmitted signal is possible by inserting a frequency shift unit into the crystal socket.

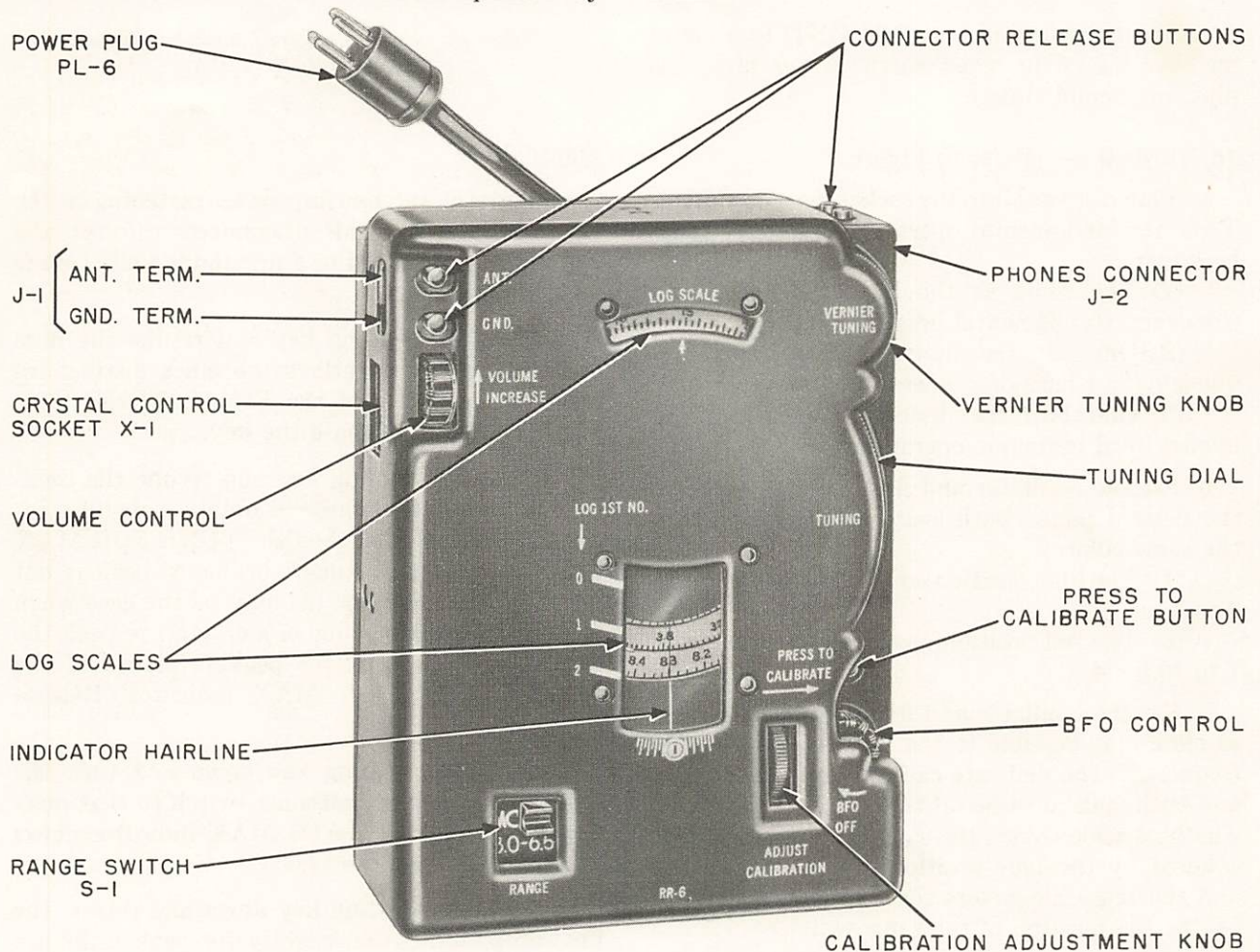

Figure 11. Receiver RR-6 showing control locations.

### SECTION III. RECEIVER RR-6

#### 18. CONTROLS AND FUNCTIONS—(See Figure 11)

- a. VOLUME—Controls volume of received signals.
- b. RANGE—Selects proper frequency band.
  - (1) Blue position—3 to 6.5 mc
  - (2) Red position—6.5 to 15 mc
- c. TUNING—Rapidly adjusts the oscillator and r-f tuned circuits to any point within receiver frequency range.
- d. VERNIER TUNING—A finer control of the large TUNING dial.
- e. PRESS TO CALIBRATE—Provides crystal-controlled frequency for dial calibration every 0.5 megacycle (500 kc).
- f. ADJUST CALIBRATION—Corrects error in dial calibration by moving the indicator hairline with respect to the dial scale.
- g. BFO—Turns the 455 kc oscillator on and off and varies the pitch of the audio signal produced.

#### 19. CALIBRATING THE TUNING DIAL

a. A signal generated by a crystal-controlled oscillator in the receiver offers a means of checking the accuracy of the frequency indicated on the dial. By means of harmonics, the 500 kc crystal provides signals in 500 kc steps throughout the dial. Thus, each megacycle mark and each half-megacycle mark become a calibration point. To calibrate the dial, proceed as follows:

(1) Set the RECVR-TRANS switch (Figure 10) on Filter-Accessory Unit RA-6 to RECVR. Although calibration can be accomplished with the RECVR-TRANS switch in the TRANS position, power consumption will be less with this switch in the RECVR position.

(2) Turn the BFO dial until zero is aligned with the white mark on the housing.

(3) Hold down the button marked PRESS TO CALIBRATE.

(4) Turn VERNIER TUNING until zero beat is heard, always tuning in from the low frequency direction to eliminate any error due to slack in the tuning system.

*NOTE:* Zero beat is the no sound point between the two sound peaks. The VOLUME control should be set at the lowest gain setting sufficient to hear the zero beat. Higher settings may make

it possible to hear spurious responses that will result in an inaccurate calibration. A beat note that sounds discordant may be an undesired spurious response. Generally, a low gain setting of the VOLUME control is sufficient at the lower frequency settings of the dial. High frequency settings of the dial usually require higher gain settings of the VOLUME control to compensate for the weaker harmonics of the 500 kc calibration crystal at those frequencies.

(5) Turn ADJUST CALIBRATION (Figure 11) until the hairline coincides with the calibration point on the dial scale.

b. When setting the receiver to a desired frequency, first calibrate the tuning dial at the closest calibration point.

#### 20. TUNING (Variable)

a. The receiver will operate with the RECVR-TRANS switch in the TRANS position when the transmitter is not keyed. Automatic switching of the antenna from the transmitter to the receiver is accomplished by the keying relay when the ANT TERM on the receiver is connected to the REC ANT post on the transmitter. When the RECVR-TRANS switch is in the RECVR position, it is necessary to connect the antenna directly to ANT TERM on the receiver.

*NOTE:* Momentarily press the sending key down after switching the RECVR-TRANS switch to the RECVR position. Until the sending key circuit is closed, the transmitter will idle, as in the case of break-in or key-up, when the RECVR-TRANS switch is thrown to RECVR. This is because the interval between the break and make of the RECVR-TRANS switch is too short to open the B supply link between the receiver and the transmitter. Pressing the sending key down will release the keying relay and remove B power from the transmitter. This can also be accomplished by folding the transmitter key into the recess on the side of the panel (only with RECVR-TRANS switch set on RECVR). If this precaution is not taken, unnecessary current drain from the battery will reduce battery life.

b. Set RANGE switch (Figure 11) for the proper frequency band:

- (1) Blue—Low band: 3—6.5 mc
- (2) Red—High band: 6.5—15 mc

c. The dial scale is calibrated directly in megacycles. Use the blue scale for the low band and the red scale for the high band.

d. First tune for stations with the TUNING (coarse) control. For more precise adjustment use VERNIER TUNING, always tuning in from the low frequency direction to eliminate any error from slack in the tuning system.

e. Calibrate the dial on the nearest megacycle or half-megacycle calibration point as directed in the previous paragraph. Turn BFO dial until zero is aligned with the white mark on the housing before calibrating dial.

*NOTE:* For a-m (voice) reception, turn BFO clockwise to OFF.

f. Set the dial to the desired frequency and then retune slightly, if necessary, for best reception.

#### **21. TUNING (Crystal)**

a. Plug the specified crystal in CRYSTAL CONTROL socket (Figure 11).

*NOTE:* The oscillator frequency is 455 kc higher than the received frequency. The fundamental, the second harmonic, or the third harmonic of a crystal may be used.

b. Tune the receiver to the desired frequency any proceed as above.

#### **22. LOG SCALE**

a. Signals may be accurately logged to three figures through the use of the LOG SCALE.

(1) After a station is accurately tuned in, note the position of the white horizontal line with respect to the numerals 0, 1, or 2 located to the left of the dial scale window. These numerals represent the first digit of the log scale.

(2) Read and record the numeral located immediately above the white horizontal line on the window for the first digit. Read and record the other two digits on LOG SCALE.

(3) Once a station is logged in, the tuning dial may be re-set by these numbers for future location of that station on the dial.

# CHAPTER 3

## MAINTENANCE

### SECTION I. RECEIVER RR-6

#### 23. CIRCUIT DESCRIPTION—(See Schematic, Figure 12)

a. Receiver RR-6 is an eight-tube superheterodyne, two-band receiver. The incoming signal is amplified by a 5899 tuned r-f stage (V1) and is transformer coupled to the mixer grid. The transformer has both inductive and capacitive coupling. The rangeswitch selects the desired antenna, r-f, and oscillator coils. When the switch is in the high band position the low band coils are shorted out to prevent undesired absorptive coupling. The 5899 local oscillator (V2) normally is a tuned plate type variable oscillator. It can be converted to crystal control by inserting the crystal into the socket (X1). A switch in the crystal socket automatically makes the necessary circuit changes. When used with crystal control it becomes a Pierce electron coupled type and the plate tank tunes to the desired harmonic of the crystal.

b. Oscillator injection is accomplished inductively by small coupling loops on the oscillator and r-f transformer coil forms. Very loosely coupled double-tuned i-f transformers (T7, T8, and T9) operating at 455 kc are used; the primaries of T8 and T9 are center-tapped to reduce plate loading. This design results in a very narrow band receiver. The mixer i-f transformer (T7) primary tap is not used because of the need for effective bypassing of the high frequency components in the mixer plate circuit. Two i-f stages (V4 and V5) are used, not so much to achieve gain, but to obtain selectivity. Large unbypassed cathode resistors (R13 and R18) are used in the i-f stages in order to prevent regeneration.

c. Plate detection is used in the 2nd detector (V6) in order to reduce loading of the 3rd i-f transformer (T9) and thereby maintain utmost selectivity. An i-f filter consisting of R23 (56K), C39 (.001), and C40 (56uuf) is in the plate of the 2nd detector to prevent i-f energy from getting into the audio amplifier. Capacitor C40, in conjunction with C51, also controls the feedback for the 500 Kc crystal calibrator.

d. By means of a capacity probe, the signal from the Hartley BFO stage (V8, 5718) is injected into the detector grid. This signal mixes with the 455 kc i-f frequency and produces an audio beat in the output of the second detector. The audio beat is applied to the audio amplifier (V7, 5718) and reaches the headphone. When the BFO is turned off, C49 is shorted out and the frequency of the tank is lowered to approximately 400 kc, which is far enough away in frequency to be rejected by the i-f amplifier. Any signal which does get to the detector produces a beat outside the audio range. With the BFO "off" the receiver can receive a-m signals. The frequency of the BFO is changed rather than turned off in order to provide the negative d-c voltage required by the volume control. A germanium crystal detector (CR1) in the BFO stage rectifies part of the oscillator tank voltage. This rectified voltage is applied as fixed bias to the detector, V6, and is also applied to the VOLUME control, R28, to control the bias of the r-f and i-f stages.

e. The audio output stage, V7, is also used as a 500 kc, crystal-controlled oscillator to provide an accurate signal for checking the calibration of the dial. Sufficient harmonics are generated to provide 500 kc check points throughout the two bands. The stage is converted to a Pierce-type oscillator by the PRESS TO CALIBRATE button, which connects the crystal (Y2) between the grid and plate. The signal is fed back to the r-f amplifier control grid by a capacity probe.

#### 24. CORRECTIVE MAINTENANCE OF RECEIVER

a. Determine precisely the cause and location of the fault before attempting the substitution of parts. Changing parts may create new difficulties. Successful repair is difficult because the RR-6 receiver is compact and complex. The general method of analysis is first to determine the faulty section and then locate the defective component within that section. A trouble-shooting chart is supplied as an aid in locating trouble.

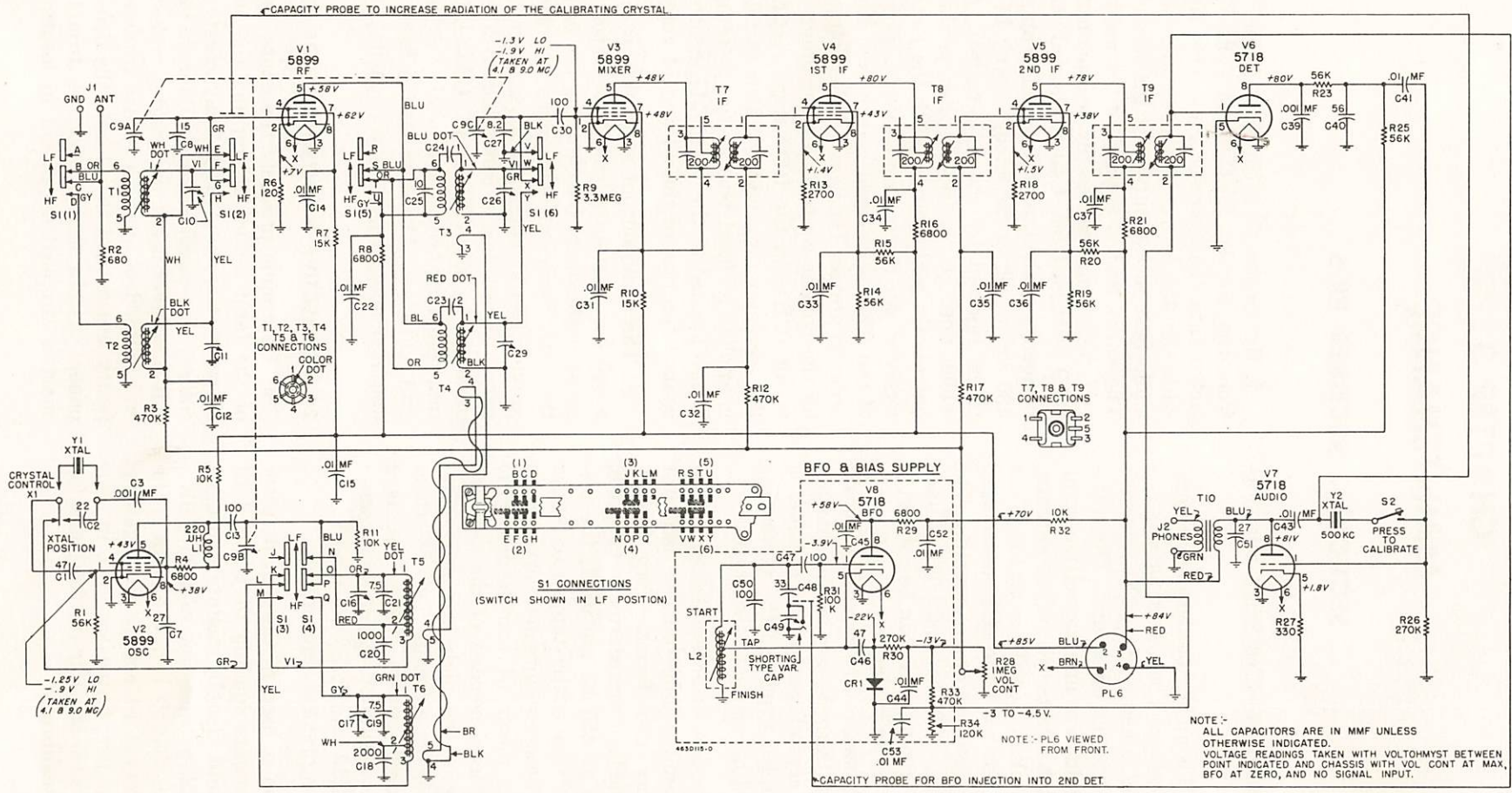

Figure 12. Receiver RR-6 schematic diagram.

This chart lists symptoms which the serviceman may observe while making a few tests. The symptoms noted will determine what further steps are to be taken. The particular stage or circuit that may be defective is indicated in the second col-

umn. Voltage and resistance measurements of the defective circuit should ordinarily be sufficient to isolate defective components not specifically mentioned.

### RECEIVER RR-6 TROUBLE-SHOOTING CHART

SYMPTOM	PROBABLE CAUSE	REMEDY
Too much variation in gain across band.	Mistracking.	Realign.
	Mistracking due to bent plates in antenna or r-f sections of variable capacitor.	Replace variable capacitor and realign.
	Insufficient oscillator injection in mixer at low end of band.	Replace oscillator tube.
	Insufficient injection due to open link circuit.	Replace or repair oscillator coil or mixer coil.
500 Kc crystal calibrator inoperative.	Defective crystal.	Replace.
	Defective switch.	Replace.
No calibration beats at upper end of high band.	Weak crystal.	Replace.
	Open feedback capacitor C40 or C51.	Replace.
Spurious beats 45 kc above or below correct beat when using crystal calibrator.	Open capacitor C39.	Replace.
	Volume control set for too much receiver gain.	Reduce volume control setting.
Beat note produced on calibration check sounds broken up and does not change pitch with tuning of variable capacitor.	Volume control set for too much receiver gain.	Reduce volume control setting.
Low sensitivity.	Low i-f gain.	Realign i-f transformers. Replace i-f tubes.
	Low r-f gain.	Realign antenna and r-f coils. Replace r-f tube.
	Insufficient oscillator injection in mixer.	Replace oscillator tube.
	Open oscillator injection link (usually broken at coil terminal).	Repair or replace coil.
	Low detector gain.	Change tube.
	Too high fixed bias on detector.	Repair bfo.
	Open r-f or i-f bypass: C32 or C12.	Replace.
	Open antenna coil.	Replace or repair.
Audio output low.	Excessive bias on detector. Should be -3 to -4.5 volts.	Repair bfo.

**RECEIVER RR-6 TROUBLE-SHOOTING CHART (Cont.)**

SYMPTOM	PROBABLE CAUSE	REMEDY
High noise output.	I-f amplifier cathode resistor shorted to ground.	Remove short.
Gain control not effective on strong signals.	Short to ground at i-f transformer grid return lug.	Remove short.
	Shorted bypass capacitor C32, C35, or C12.	Replace.
	Bfo not operating or operating weakly.	Repair bfo.
	Bfo signal not rectified.	Replace crystal CR1.
Dial calibration incorrect.	Improper oscillator alignment.	Realign receiver.
	Bent oscillator plates in variable capacitor.	Replace gang.
No beat heard on cw signal.	Bfo coil improperly aligned.	Align bfo coil.
	Bfo trimmer shorted.	Remove short.
Squeal heard on a-m signal reception.	Bfo trimmer not shorting because stop is bent or broken.	Replace bfo trimmer.
Fine tuning mechanism binds when rotating large dial by hand.	Rubber idler shaft in fine tuning mechanism improperly aligned.	Remove assembly and adjust.
	Screw holding fine tuning bracket and earphone jack to post loose.	Tighten screw.
	Pivot bolt on fine tuning assembly too loose.	Take out looseness by tightening nut.
No B+ voltage.	Broken lead in plug.	Repair.
No filament voltage.	Broken lead in plug.	Repair.
B+ much higher than 105 volts.	Defective voltage regulator tube in filter	Replace.

b. Use of the Signal Input Chart will make it possible to locate the defective section to correct a set having low over-all gain.

c. Low over-all gain could be the result of trouble in any of the following sections: the audio amplifier, the detector, the i-f or r-f amplifiers or the antenna coil. The first step is to measure the sensitivity of the receiver at the various stages starting with the antenna input and proceeding toward the audio output stage. By consulting the Signal Input Chart, the nominal input at each grid is known for 5 mw of audio output. A .01 uf capacitor should be connected in series with the hot lead of the signal generator so as not to upset the bias at the test signal input points. The gain of the audio stage can be measured best with an

audio oscillator such as a Hewlett Packard Model 200C.

**SIGNAL INPUT CHART**

Signal generator output connection	Frequency 400 cps 30% modulation	Signal generator output (uv)
Antenna terminal through a 270 ohm resistor. RF grid, pin 1, V1.	3.0 mc	10
	9.0 mc	10
	3.0 mc	19
	9.0 mc	19
Mixer grid, pin 1, V3.	455 kc	65
1st i-f grid, pin 1, V4.	455 kc	15,300
2nd i-f grid, pin 1, V5.	455 kc	170,000
Det grid, pin 1, V6.	455 kc	1,000,000
Det grid, pin 1, V6.	400 cycles	200,000
Audio grid, pin 1, V7.	400 cycles	800,000

d. The conversion gain of the mixer stage may be low due to insufficient oscillator injection voltage. With the oscillator grid, pin 1 of V2, shorted to ground, measure the contact potential at the grid, pin 1 of the mixer tube, V3, using the d-c probe of a vacuum tube voltmeter. The residual contact potential usually measures from .5 to .8 volt. Remove the short from the oscillator and observe the rise of potential on the mixer grid. The oscillator injection voltage should result in a rise of .5 volt or more above the residual contact potential. Any value less than this indicates insufficient injection of the oscillator signal.

e. Low gain in the antenna or r-f stage will result in low receiver sensitivity. To check antenna and r-f gain, remove the oscillator injection voltage to the mixer by shorting the grid, pin 1, of the oscillator tube, V2, to ground. Place the d-c probe of a vacuum tube voltmeter on the grid, pin 1, of V3. Set the volume control at the maximum position. Use a 470K ohm resistor in series with the probe to avoid detuning the grid circuit. The voltage measured at the grid of V3 will be the residual contact potential and will be approximately .5 to .8 volt. Connect the output of a signal generator (GR-805C) to the antenna terminal through a 270 ohm resistor. The Antenna and RF stage gain chart lists the input voltage necessary to produce a rise of .5 volt over the residual contact potential at the mixer grid.

ANTENNA AND R-F STAGE GAIN CHART			
Band	Frequency (mc)	Signal generator output connection	Signal generator output (uv) (for increase of .5V at mixer grid)
Low	3.5	Antenna terminal through 270 ohm resistor.	20,000-35,000
	6.0	Antenna terminal through 270 ohm resistor.	30,000-60,000
High	7.0	Antenna terminal through 270 ohm resistor.	20,000-35,000
	15.0	Antenna terminal through 270 ohm resistor.	30,000-60,000
Low	3.5	RF grid through 10,000 uuf capacitor.	30,000-70,000
	6.0	RF grid through 10,000 uuf capacitor.	50,000-120,000
High	7.0	RF grid through 10,000 uuf capacitor.	30,000-70,000
	15.0	RF grid through 10,000 uuf capacitor.	50,000-120,000

f. A diagram of point-to-point resistance measurements on the r-f rangeswitch is provided to locate defective coils easily. See figure 13. It is advisable to obtain an ohmmeter capable of accurate readings down to .01 ohm such as the Weston Model 301. If such a meter is not obtainable, a suitable low range ohmmeter can be constructed and calibrated as shown in figure 26.

## 25. BFO PANEL REMOVAL

To facilitate testing and circuit checking, the wires connected to the BFO panel are long enough to permit removal of the panel without interrupting circuit operation. The only wire which must be disconnected is the blue wire which serves as the capacity probe for BFO injection into the second detector. The excess wire is folded over the top of the panel and secured with a clamp. To remove the BFO panel, remove the six retaining screws, release the clamp holding the excess wires and lift out the panel.

## 26. ALIGNMENT

### a. Equipment Required

#### (1) AM signal generator having:

- frequency coverage from 455 Kc to 16 mc.
- accurately calibrated, adjustable output.
- 400 cycle, 30% modulation.

#### (2) Output power meter, GR type 583-A or equivalent.

(3) Non-metallic screwdriver with  $\frac{1}{8}$ " blade (for i-f transformers).

(4) Small size screwdriver to fit antenna, r-f, and oscillator transformers.

(5) Medium size screwdriver with blade ground to fit trimmer slots without play. Blade should not ride in bottom of slot.

### b. Procedure

(1) Connect the equipment, as directed in Chapter 2, Section I (do not connect phone when the output meter is used, as the output load impedance will be reduced by one-half).

(2) Set RECVR-TRANS switch on Filter-Accessory Unit RA-6 to RECVR.

(3) Expose bottom alignment adjustments as follows (see Figure 14):

- i-f—slide cover plate to right.
- bfo—turn cover plate counterclockwise.
- r-f—remove two screws and cover plate.

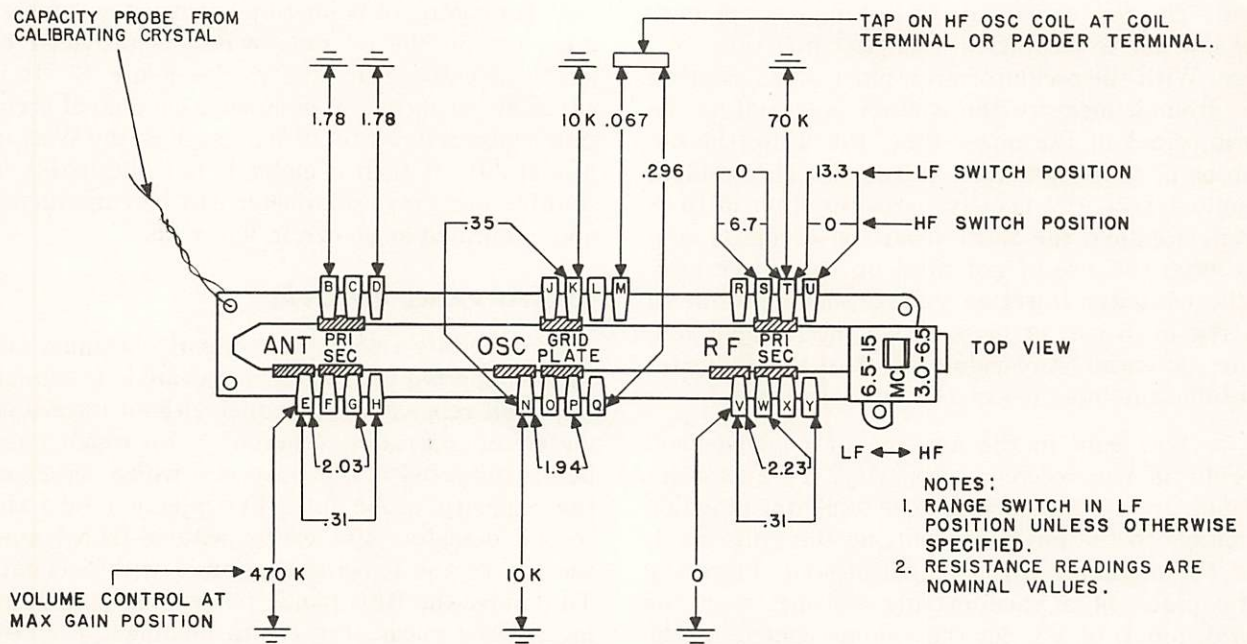

Figure 13. Point-to-point Resistance Measurements on Rangeswitch.

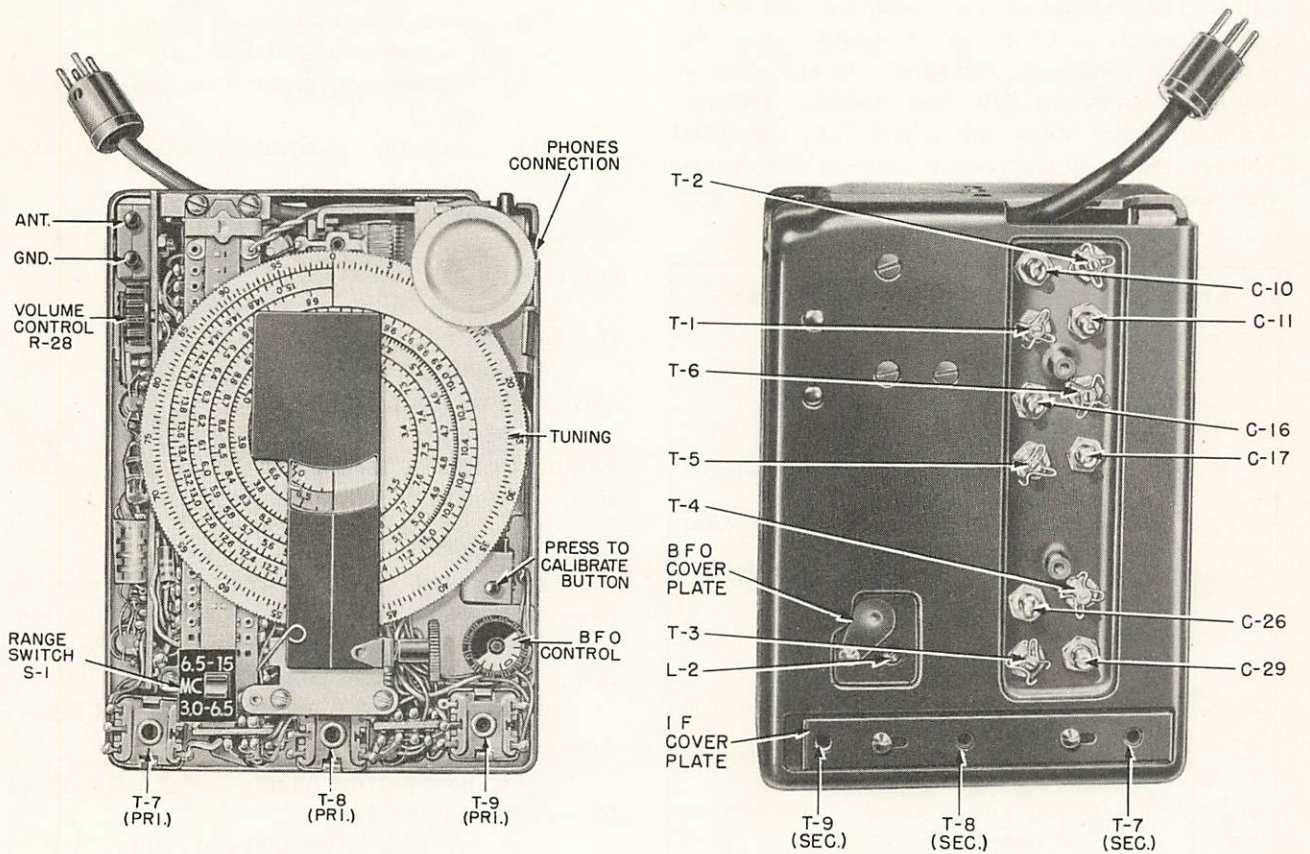

Figure 14. Receiver RR-6, top and bottom views showing alignment adjustment locations.

(4) Connect the output meter across the phones terminals J2. Set the "OHMS" knob to 40 and the impedance multiplier to 100. Set the meter multiplier to 1.

**NOTE:** Throughout the alignment procedure, reduce the generator output to a level which produces about 5 mw output indication on the output meter. This will avoid overloading the receiver.

(5) Remove the top cover and turn VOLUME control to maximum volume.

(6) Refer to Figure 14 for adjustment locations.

(7) Remove glyptal from the cores and trimmers in the r-f section with lacquer thinner or acetone. If thinner doesn't loosen the core sufficiently, apply the heat from a soldering iron.

#### c. IF Alignment

(1) Connect the AM generator to the grid of the mixer (pin 1, V3—See Figure 15—RF panel front view) and set it to 455 kc with 400 cycle, 30% modulation. Detune the receiver to remove unwanted signals.

(2) Set the generator output high enough to give about 5 mw output on the meter.

(3) Tune the primaries and secondaries of T9, T8, and T7 for maximum output on meter. (See Figure 14).

(4) The i-f sensitivity is normal if a generator output of 100 microvolts or less produces 5 mw output.

#### d. BFO Alignment

(1) With the equipment connected as above, turn off generator modulation, and set the BFO dial to zero. (The zero on the dial should be at three o'clock when viewed as in Figure 14.)

(2) Adjust the bfo coil (L2) for zero beat.

(3) After alignment of the bfo, apply glyptal to the adjustment screw.

#### e. RF Alignment

(1) Replace the top cover which was removed during i-f alignment, and place the receiver on its side.

(2) Connect the generator to the ANT-GND terminals (J1). Use a 270 ohm carbon resistor (dummy antenna) in series with the antenna terminal.

**NOTE:** This value is for a 30-ohm generator. If generator output impedance is other than 30 ohms, subtract the generator impedance from 300 ohms for the correct value of dummy antenna.

(3) Turn BFO dial to OFF.

(4) Set low-band trimmers C10, C16, and C26 so that screwdriver slots are parallel to the long edge of the compartment. This represents the mid-capacity positions.

(5) Turn the TUNING dial clockwise until it reaches the end stop (low frequency end). Then turn the VERNIER counterclockwise slightly to take up any slack in the drive.

(6) Turn ADJUST CALIBRATION knob until the hairline passes through the center of the circle at the bottom of the dial window.

(7) Set the generator frequency to 3.5 mc and the generator output to 100 microvolts with 400 cycle, 30% modulation.

(8) Set RANGE switch to "blue" position (3 to 6.5 mc).

(9) Set the receiver tuning dial at 3.5 mc.

(10) Tune the oscillator slug in T5 for maximum output on the meter.

**CAUTION:** Do not turn the slug too far into the coil; when turning becomes difficult, do not force, as damage to the terminal assembly may result.

**NOTE:** For final adjustment of the slug, reduce the generator output until a receiver output of 5 mw is obtained.

(11) Tune the slugs in T1 (antenna), T3 (r-f) and T5 (oscillator) for maximum output.

(12) Set the receiver and generator dials for alignment at 6.0 mc.

**CAUTION:** There will be two generator frequencies which will produce an output indication. One will be near the frequency setting of the receiver and the other, the image frequency, will be 0.91 mc higher. The lower one is the correct alignment frequency.

(13) Adjust the oscillator trimmer (C16) and antenna trimmer (C10) for maximum output. Do not adjust T1, T3, or T5.

(14) Since the r-f trimmer (C26) has some pulling effect on the oscillator, it will be necessary to find the true resonant frequency of the r-f tank by a "rocking" procedure as follows:

(a) Note the output reading on meter.

(b) Turn the r-f trimmer (C26) slightly counterclockwise until the output drops approximately one-third to one-half.

(c) Readjust the oscillator trimmer (C16) for maximum output.

(d) If the maximum reading is higher than that in step (a), repeat steps (a), (b), and (c), until the highest output is obtained. Lower the

A.  
3.5 Mc.

(40)

(20) (30)

(40)

B

(50)

(60)

(40)

(80)

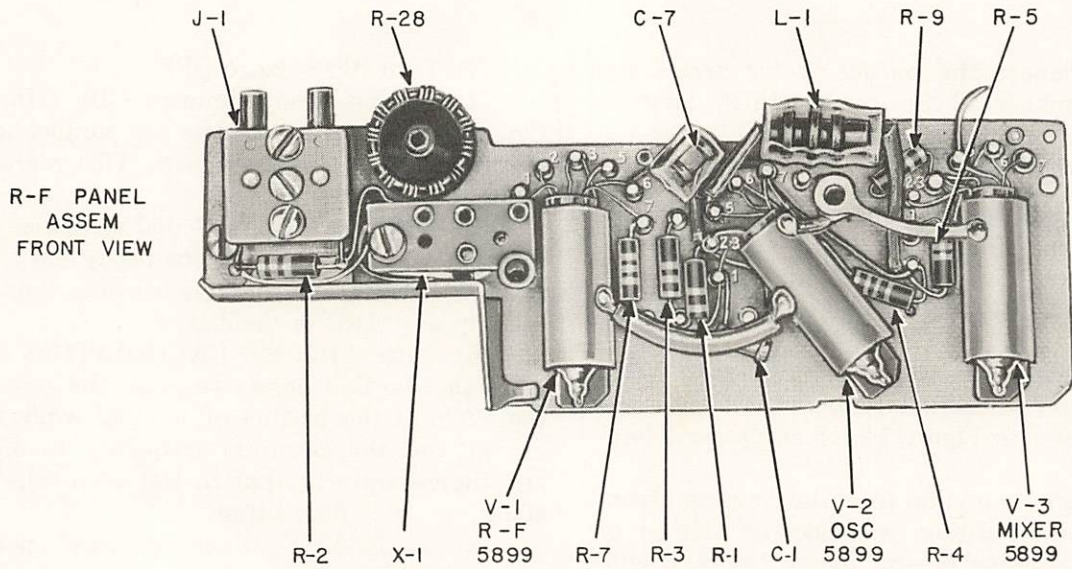

1ST I-F AMP  
PANEL ASSEM  
FRONT VIEW

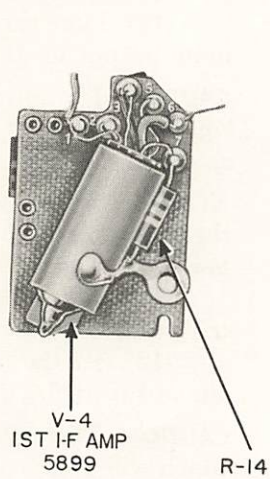

1ST I-F AMP  
PANEL ASSEM  
REAR VIEW

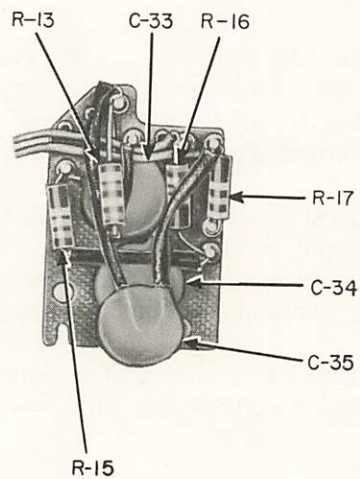

DETECTOR  
&  
AUDIO PANEL  
ASSEM

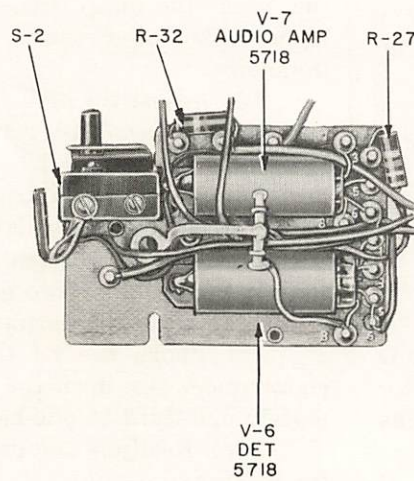

FRONT VIEW

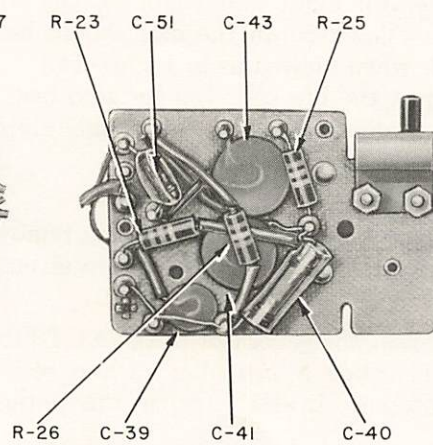

REAR VIEW

Figure 15. Receiver RR-6, showing

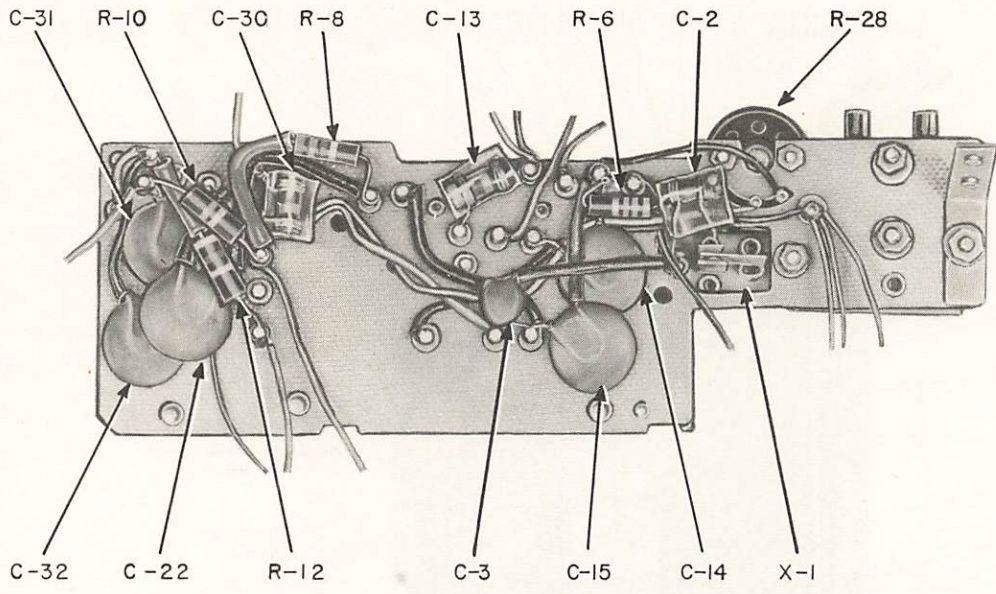

R-F PANEL ASSEM  
REAR VIEW

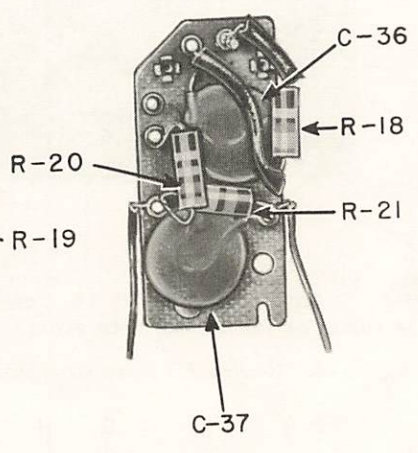
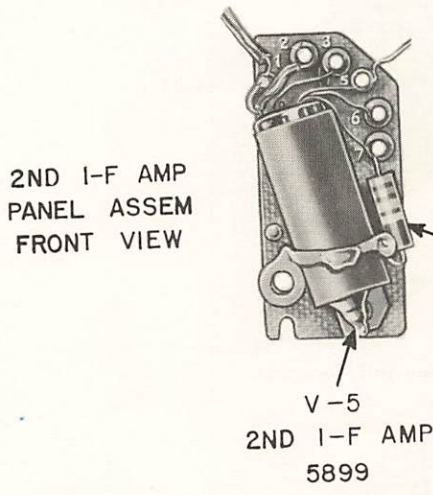

2ND I-F AMP  
PANEL ASSEM  
REAR VIEW

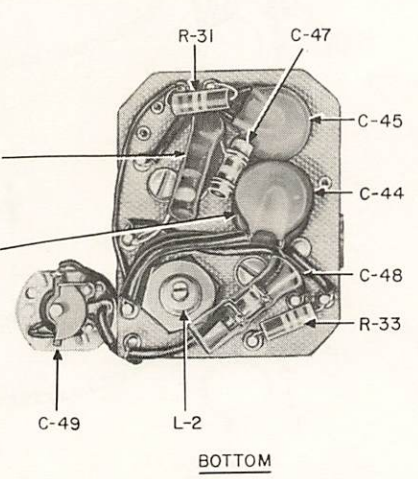
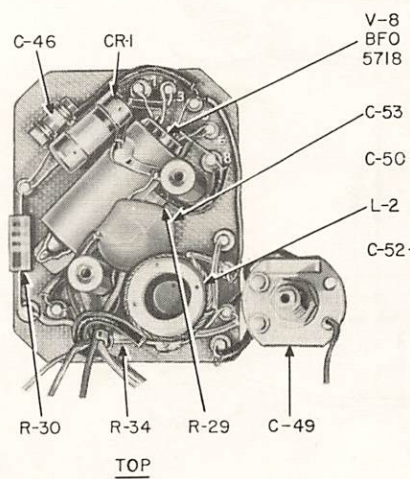

BFO  
PANEL ASSEM  
TOP  
&  
BOTTOM  
VIEW

panel assembly parts locations.

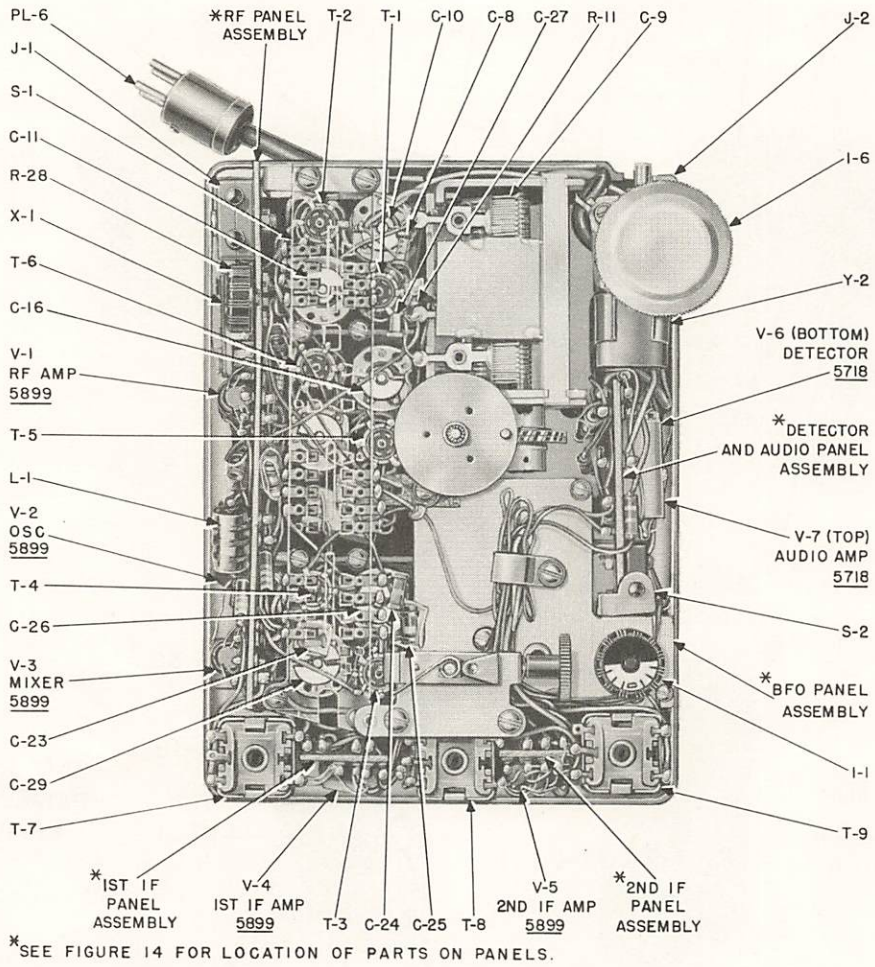

Figure 16. Receiver RR-6, top views showing parts locations.

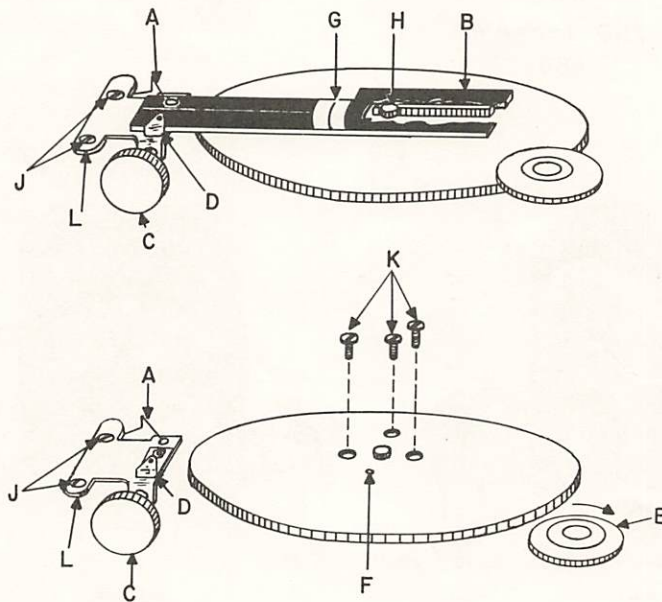

Figure 17. Disassembly of Receiver RR-6 dial mechanism.

generator output as required to keep the output around 5 mw.

(e) If in step (d) the maximum reading is lower than that in step (a), it indicates that the r-f resonance has been passed. In this case, repeat steps (a), (b), (c), and (d), turning r-f trimmer (C26) clockwise instead of counterclockwise.

(15) After the true r-f resonance has been found, recheck the alignment of T1, T3, and T5 at 3.5 mc.

(16) If it was necessary to move any of the slugs (T1, T3, or T5) while rechecking the alignment at the low alignment point on the dial (3.5 mc), recheck the alignment at the high alignment point on the dial (6.0 mc).

**NOTE:** Because of the extreme accuracy desired in this receiver, it is well to recheck the alignment at both the low and high alignment points on the dial three times. After the first alignment the r-f resonance should be close enough to the true resonance so that only the oscillator trimmer and slug need be re-adjusted.

(17) After the low band has been accurately aligned, apply glyptal to the low-band trimmers and slugs.

(18) Set RANGE switch to "red" position (6.5-15 mc).

(19) Set the receiver and generator dials at 7.0 mc.

**CAUTION:** Check for image frequency as in step 12.

(20) Turn trimmers C11, C17, and C29 so that the slots are parallel to the long edge of the compartment.

(21) Tune oscillator slug in T6 for maximum output.

**CAUTION:** Do not force slug into the coil.

(22) Tune T2, T4, and T6 slugs for maximum output.

(23) Set the generator and receiver dials at 14.5 mc.

(24) Adjust the oscillator trimmer (C17) and antenna trimmer (C11) for maximum output.

(25) Repeat the "rocking" procedure as described for the 3 to 6.5 mc band in step 14 to find the true resonant frequency of the r-f tank. In this case, however, adjust the r-f trimmer C29, and oscillator trimmer C17.

(26) Repeat the alignment at both the low and high alignment points on the dial three times.

(27) Replace glyptal on trimmers and slugs.

(28) The set when properly aligned will have a sensitivity on both bands of less than 20 micro-

volts for 5 milliwatts output.

#### f. Alignment by Crystal

(1) The receiver may be aligned in the field by replacing the a-m signal generator with the radiated signal from the calibrating crystal and by using the phone as an output indicator. The alignment procedure is the same as with the generator except that the bfo is turned on. The gain of the receiver must be reduced sufficiently after the beat is located to permit hearing a change of volume when the adjustments are made.

(2) If aligned on the image, the dial calibration will be off and large sensitivity variations will be noticed over the band. Aligning on an image or wrong harmonic of the crystal will result in an abnormal position of the coil slugs and trimmers. The slugs normally extend  $\frac{1}{16}$ " to  $\frac{3}{16}$ " beyond the end of the coil base. The slots in the trimmers are normally less than perpendicular to the long edge of the compartment. A slot perpendicular to the long edge would very likely indicate that the set is misaligned.

### 27. DIAL SCALE MECHANISM—DISASSEMBLY AND REASSEMBLY — (Refer to Figure 17)

#### a. DISASSEMBLY

(1) Lift the frequency channel indicator (B) up at the large end, and slide out of spring clamp (D).

(2) Remove the screws (J) and remove the assembly consisting of (A), (C), (D), and (L).

(3) Remove the three screws (K).

(4) Push the vernier (E) in the direction indicated until it clears the dial. Hold it in position until the dial scale has been removed.

(5) Remove the dial by lifting straight up, because it fits snugly on hub.

#### b. REASSEMBLY

(1) Replace dial, placing pin in hole (F).

(2) Replace screws (K).

(3) Replace the assembly consisting of (A), (C), (D), and (L) and screws (J).

(4) Turn the dial until the tuning capacitor is fully meshed.

(5) Hold spring (A) back and insert the end of frequency channel indicator (B) into spring clamp (D) until the white line (G) falls over the line between the top two scales on dial.

(6) Engage the pinion gear (H) with the rack gear teeth on rear of frequency channel indicator (B).

(7) Make sure the end loop on spring (A) rests on *top* of frequency channel indicator (B).

## SECTION II. TRANSMITTER RT-6

### 28. CIRCUIT DESCRIPTION—(See Schematic, Figure 18)

a. Transmitter RT-6 is a two-stage, crystal-controlled, CW transmitter. It has two bands with variable capacitors that provide oscillator and final tuning.

b. A keying relay is employed in the RT-6 to switch the necessary circuits for break-in operation. Closing the key removes the blocking bias from the cathode of V101 (6AG5), causing oscillations to develop in the modified Pierce electron-coupled oscillator stage. A keying filter, consisting of C101 (1 uf), R102 (68K), and LR101 (80 uh, 560 ohms) in the oscillator circuit and C116 (5 uf) and the cathode circuit resistance in the RF power amplifier stage, properly shapes the keyed character to eliminate "clicks". Cathode current from the r-f power amplifier (V102, 2E26) flows through the relay coil. The relay armature is held when the transmitter is not keyed. The added resistance of the relay coil is sufficient to increase the cathode bias of the 2E26 to prevent excessive power from being dissipated in the r-f power amplifier when no grid drive is applied. Closing the key shorts the relay coil, bypassing the 2E26 cathode current to ground, and releases the relay armature. This switches B power from the receiver and applies the B power to the 6AG5 oscillator screen grid and to the neon bulb relaxa-

tion oscillator (E104) which develops the sidetone for monitoring the transmitter. When the key is closed, the terminal labeled REC ANT is grounded through C115 (.01) to prevent the transmitted signal from paralyzing the receiver. Releasing the relay armature also switches the antenna from the receiver to the transmitter. A bug key when inserted halfway into the KEY JACK will operate the relay the same as the attached sending key. An automatic tape keyer when inserted all the way into the KEY JACK shorts out the relay and adds into the 2E26 cathode circuit a 1200 ohm resistor which holds the plate current to a safe value in the key up position. In the key down position, this resistor is shorted out.

c. L102, in the plate of the power amplifier, is a parasitic suppressor.

d. A five-position rotary switch provides a range of output impedances for maximum antenna output. Each position doubles the impedance of the previous position from 75 ohms on position 1 to 1200 ohms on position 5. An incandescent bulb, E103, serves as an antenna current indicator.

e. Resonance of the oscillator and final amplifier plate tanks is indicated by the maximum glow of two neon bulbs, E101 and E102, respectively.

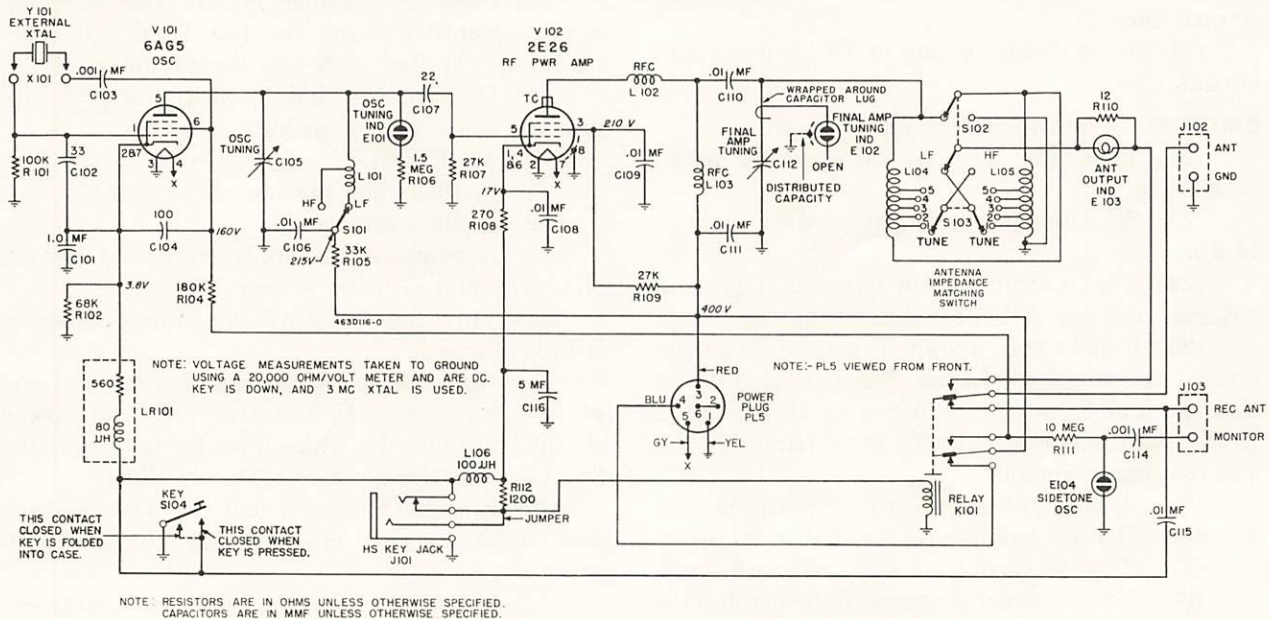

Figure 18. Transmitter RT-6, schematic diagram.

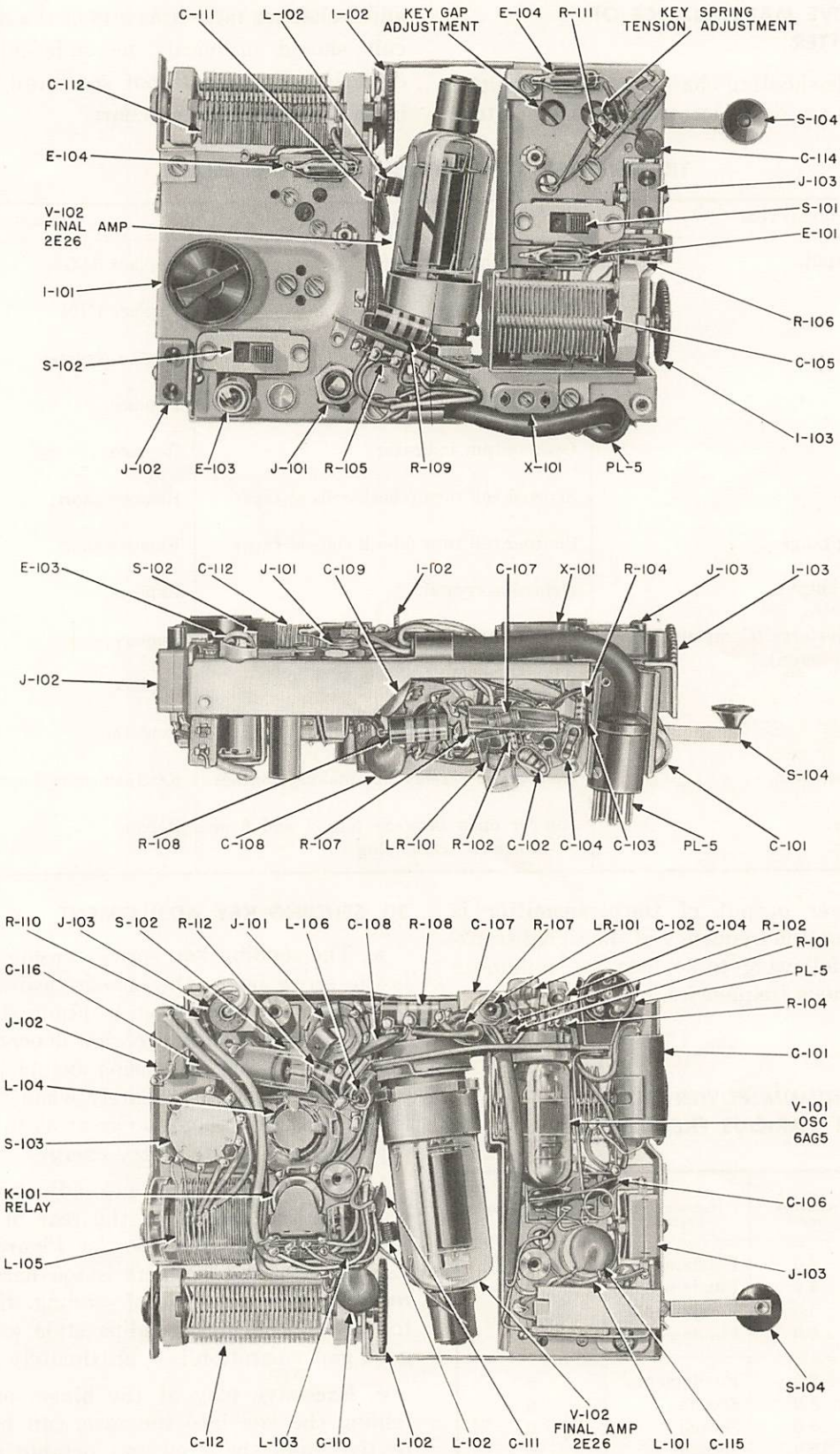

Figure 19. Transmitter RT-6, parts location.

**29. CORRECTIVE MAINTENANCE OF TRANSMITTER**

a. A trouble-shooting chart for the transmitter is supplied as an aid in locating trouble. Voltage

and resistance measurements of the defective circuit should ordinarily be sufficient to isolate defective components not specifically mentioned in the trouble-shooting chart.

**TRANSMITTER RT-6 TROUBLE-SHOOTING CHART**

SYMPTOM	PROBABLE CAUSE	REMEDY
Low power output.	Low oscillator output.	Replace 6AG5.
	Shorted bypass.	Replace C106.
	Defective crystal.	Replace crystal.
	Weak 2E26.	Replace.
	Open output indicator.	Replace.
	Shorted coil turn (check coils at taps).	Remove short.
Limited tuning range.	Shorted coil turn (check coils at taps).	Remove short.
Low harmonic output.	Defective crystal.	Replace.
Poor keying waveform. (Complaint of key clicks from listener.)	Open C101 or C116.	Replace.
	Defective crystal.	Replace.
No sidetone.	Defective neon bulb.	Replace.
No break-in operation.	Receiver B+ relay not making contact.	Readjust contact or replace relay.
No B+ voltage.	Jumper open between pins 2 and 6 on transmitter cable plug.	Repair.

b. The power output of the transmitter is dependent upon the frequency of the signal transmitted. The following table lists the minimum output at various frequencies.

**MINIMUM POWER OUTPUT FOR VARIOUS FREQUENCIES**

Band	Frequency (mc)	Harmonic of Crystal	Minimum Output (watts)
Low	3.0	Fundamental	9
	4.0	Fundamental	9
	5.0	Fundamental	9
	6.0	Fundamental	9
High	7.0	Fundamental	6
	8.0	Second	6
	10.0	Second	6
	12.0	Second	6
	15.0	Third	6

**30. SENDING KEY ADJUSTMENT**

a. The sending key spring tension adjustment is the screw below the chassis nearest the knob of the sending key shown in Figure 19. The preferred degree of spring tension depends upon the operator. The spring tension should be sufficient to open the key immediately when the pressure is released and yet not so great as to require the expenditure of unnecessary energy.

b. The sending key gap adjustment is the screw on the chassis to the rear of the spring tension adjustment screw. See Figure 19. If the gap between the contacts is too narrow, it will result in a jittery style of sending. If the gap is too wide, a sluggish sending style will result. A good gap separation is approximately .025 inches.

c. Excessive play at the hinge, provided for folding the key into the case, can be taken up by tightening the screw and lock-nut at the pivot point.

### SECTION III. POWER SUPPLY RP-6

**31. CIRCUIT DESCRIPTION**—(See Schematic Diagram, Figure 20)

**a. AC**—An eight-tap primary on the transformer provides for a wide range of input voltages at frequencies from 40 to 400 cps. The secondary voltage is rectified by a full-wave rectifier tube (6X4) and passed on to the Filter-Accessory Unit RA-6.

**b. Battery**—The 6-volt dc is converted to ac and stepped up by the vibrator and transformer. It is rectified by a type 6X4 rectifier tube and passed on to the Filter-Accessory Unit RA-6. L201, L202, C203, C204, and C205 serve as hash suppressors.

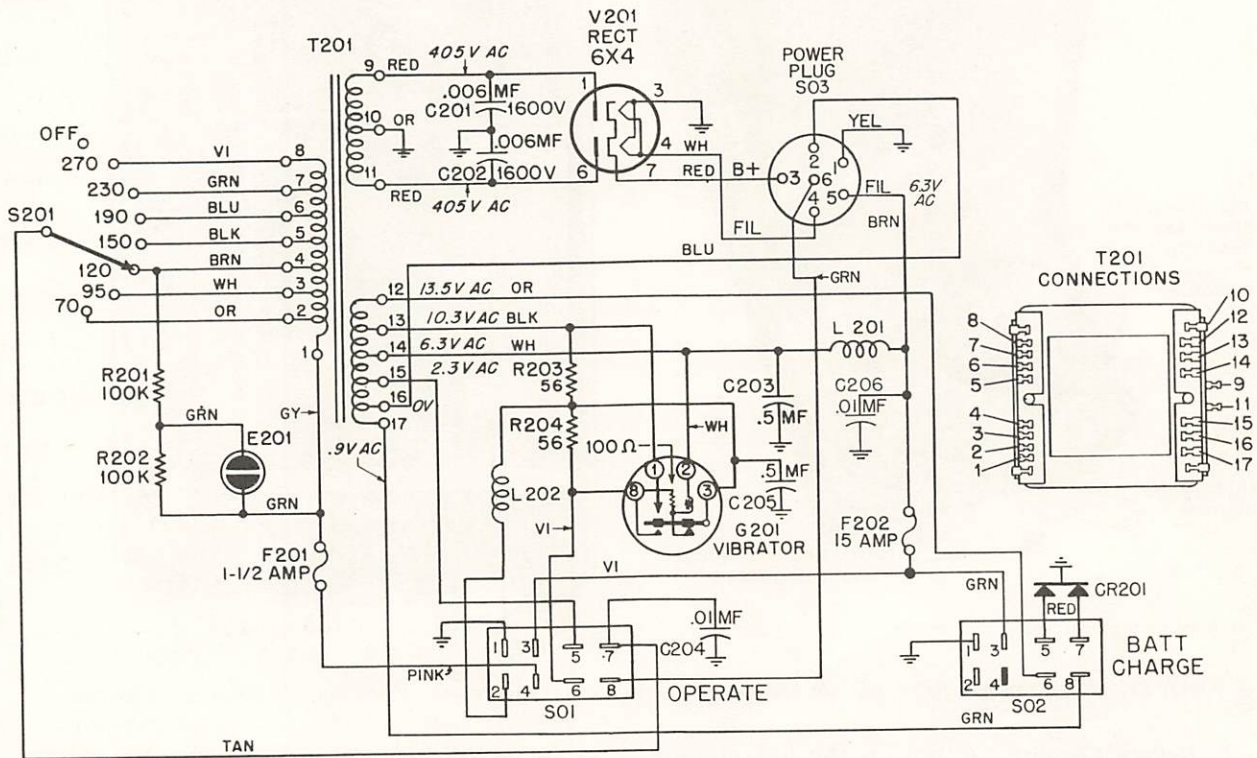

NOTE: VOLTAGE MEASUREMENTS TO GROUND USING A 20,000 OHM/VOLT METER AND ARE DC UNLESS OTHERWISE SPECIFIED. AC OPERATED.

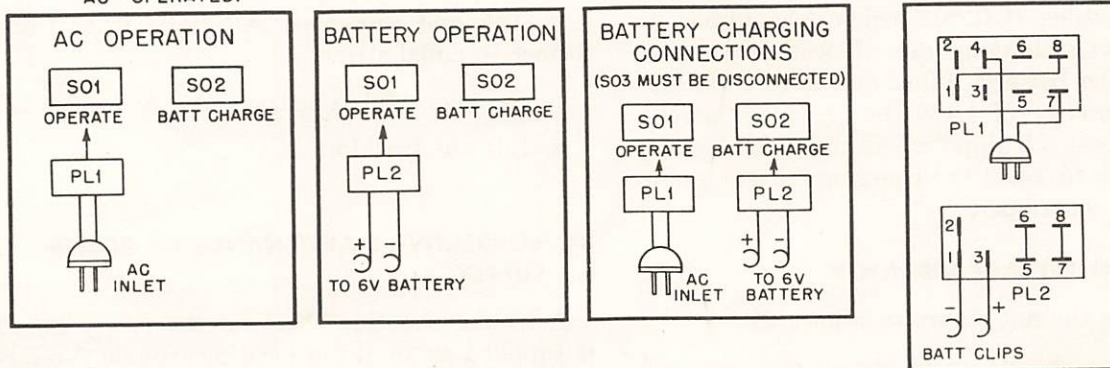

NOTES: ALL PLUGS VIEWED FROM FRONT. RESISTORS ARE IN OHMS UNLESS OTHERWISE SPECIFIED.

Figure 20. Power Supply RP-6, schematic diagram.

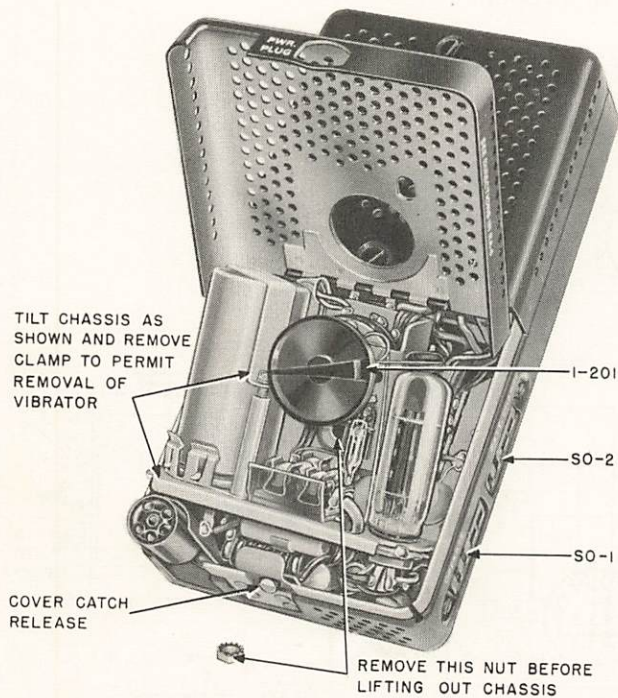

Figure 21. Power Supply RP-6, vibrator replacement.

c. **Battery Charging**—A tap on the low voltage winding of the transformer provides suitable power for charging a battery with the full-wave selenium rectifier (CR201) which is contained in the unit. The charging rate depends upon the charge in the battery. When the electrolyte has a specific gravity of 1.180 the charging current will be at least 3.5 amperes. As the specific gravity increases to 1.280 the charging current gradually drops 0.8 ampere.

### 32. HOW TO REPLACE VIBRATOR

- a. Loosen the nut shown in Figure 21.
- b. Tilt the chassis up as shown and take off the clamp holding the vibrator in the socket by removing the two screws at the ends of the clamp.
- c. Remove the vibrator by lifting it out.

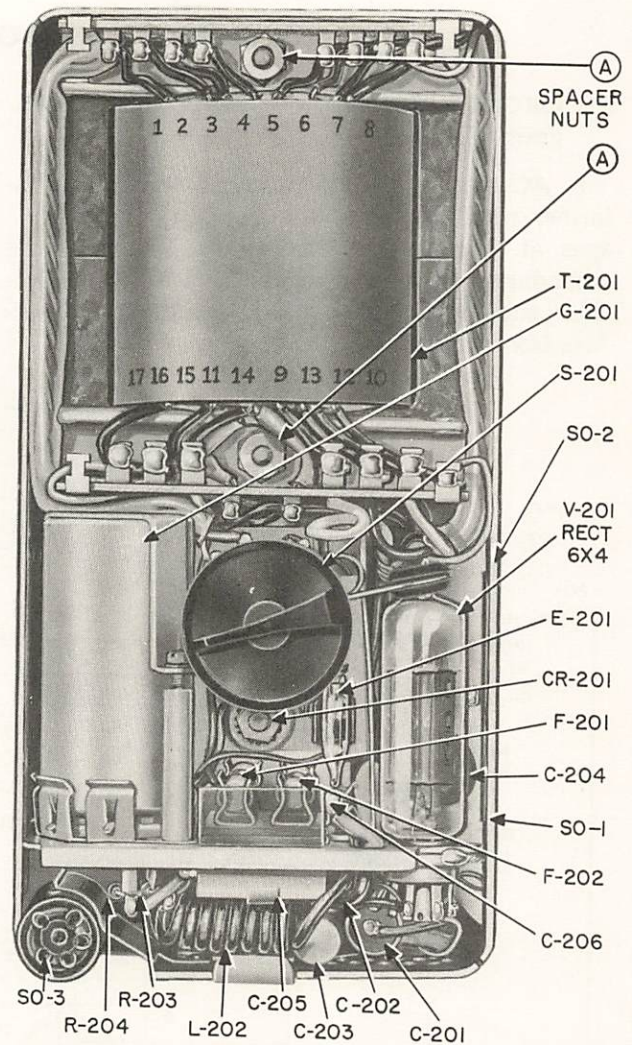

Figure 22. Power Supply RP-6, parts location.

### 33. HOW TO REPLACE POWER TRANSFORMER (See Figure 22)

- a. Tag and disconnect all leads from transformer terminal strips.
- b. Remove the hex spacer nuts (A, Figure 22).
- c. Lift out transformer.

### 34. CORRECTIVE MAINTENANCE OF POWER SUPPLY

A trouble-shooting chart for the power supply is supplied as an aid in locating trouble. Voltage and resistance measurements of the defective circuit should ordinarily be sufficient to isolate defective components not specifically mentioned in the trouble-shooting chart that follows.

### POWER SUPPLY RP-6 TROUBLE-SHOOTING CHART

SYMPTOM	PROBABLE CAUSE	REMEDY
15 amp fuse blown.	Shorted buffer capacitor C201 or C202.	Replace.
Excessive vibrator hash in receiver.	Worn vibrator G201.	Replace.
	Open capacitor C205.	Replace.
Battery discharges instead of charging under battery charging operation.	Shorted selenium rectifier CR201.	Replace.
Neon bulb E201 fails to light with line voltage applied to proper tap position.	Defective neon bulb E201.	Replace with red-tipped neon bulb.*
Neon bulb E201 lights with line voltage switch set one position higher than correct position.	Defective neon bulb E201.	Replace with red-tipped neon bulb.*
No filament voltage.	Open lead at power plug SO3.	Repair.
No B+ voltage.	Open lead at power plug SO3.	Repair.
1.5 amp fuse blown.	Shorted filter capacitor C301 or C302 in Filter unit.	Replace.
	Shorted rectifier tube 6X4.	Replace.
	Open regulator tube in Filter unit causing excessive receiver voltage.	Replace.
	Open resistor R301, R302, R303 or R304.	Replace.

\*Red-tipped neon bulbs are for Power Supply only. (Ionizing Potential 53-55V rms)

## SECTION IV. FILTER-ACCESSORY UNIT RA-6

### 35. CIRCUIT DESCRIPTION—(See Schematic Diagram, Figure 23)

a. **AC Operation**—The Filter-Accessory Unit RA-6 filters the dc from the power supply and delivers it to the transmitter and receiver. Two 5644 (or 5787) voltage regulator tubes provide regulation for the receiver supply. The filter unit provides four output voltages.

- (1) 6.3-v ac at 2.4 amperes for filaments,
- (2) 400-v dc at 75 ma (unregulated) for the transmitter,
- (3) two 90-v dc at 25 ma (regulated) taps for the receiver.

The B supply for the transmitter or the receiver is chosen by a DPDT switch marked RECVR-TRANS. When in the RECVR position, power is applied only to the RECVR. When in the TRANS position, power is applied to the transmitter and also to the receiver when not transmitting through the break-in relay located in the transmitter.

b. **Battery Operation**—Filter-Accessory Unit RA-6 performs the same under battery operation

as under ac. The output voltages are also the same except that the filament voltage is dc instead of ac and is furnished by the battery.

c. **Interlock**—An interlock is provided in PL3 to avoid damage to the rectifier or input filter capacitor should the input power be applied when no load is connected to the power supply output.

If the power is applied to Power Supply RP-6 alone, both the filaments and the cathode of the rectifier are open because SO3 and PL3 are disconnected.

If only Filter-Accessory Unit RA-6 is connected to the power supply, there are two conditions possible:

(1) With the toggle switch set at TRANS the rectifier filaments are connected, but SO5 is disconnected and the cathode circuit is open.

(2) With the toggle switch set at RECVR, the rectifier cathode is connected to the input filter capacitor; however, the filter output is connected to the voltage regulator stages, and the load is sufficient to keep the voltage across the input capacitor at a safe value.

### 36. HOW TO DISASSEMBLE

a. Remove the two flat head screws from bottom of housing.

b. Remove the three screws on the cover (A, Figure 10).

c. The chassis can then be lifted from the housing and serviced without disconnecting the choke leads.

d. To remove the choke, remove the two binderhead screws on bottom of housing, and lift out.

### 37. CORRECTIVE MAINTENANCE OF FILTER-ACCESSORY UNIT

A trouble-shooting chart for the filter-accessory unit is supplied as an aid in locating trouble. Voltage and resistance measurements of the defective circuit should ordinarily be sufficient to isolate defective components not specifically mentioned in the trouble-shooting chart that follows.

**FILTER-ACCESSORY UNIT RA-6 TROUBLE-SHOOTING CHART**

SYMPTOM	PROBABLE CAUSE	REMEDY
Receiver voltage much higher than normal.	Open regulator tube.	Replace.
	Open resistor R301, R302, R303, or R304.	Replace.
No B + voltage.	Broken lead at plug PL3.	Repair.
	Open choke L301.	Replace.
No filament voltage.	Broken lead at plug PL3.	Repair.

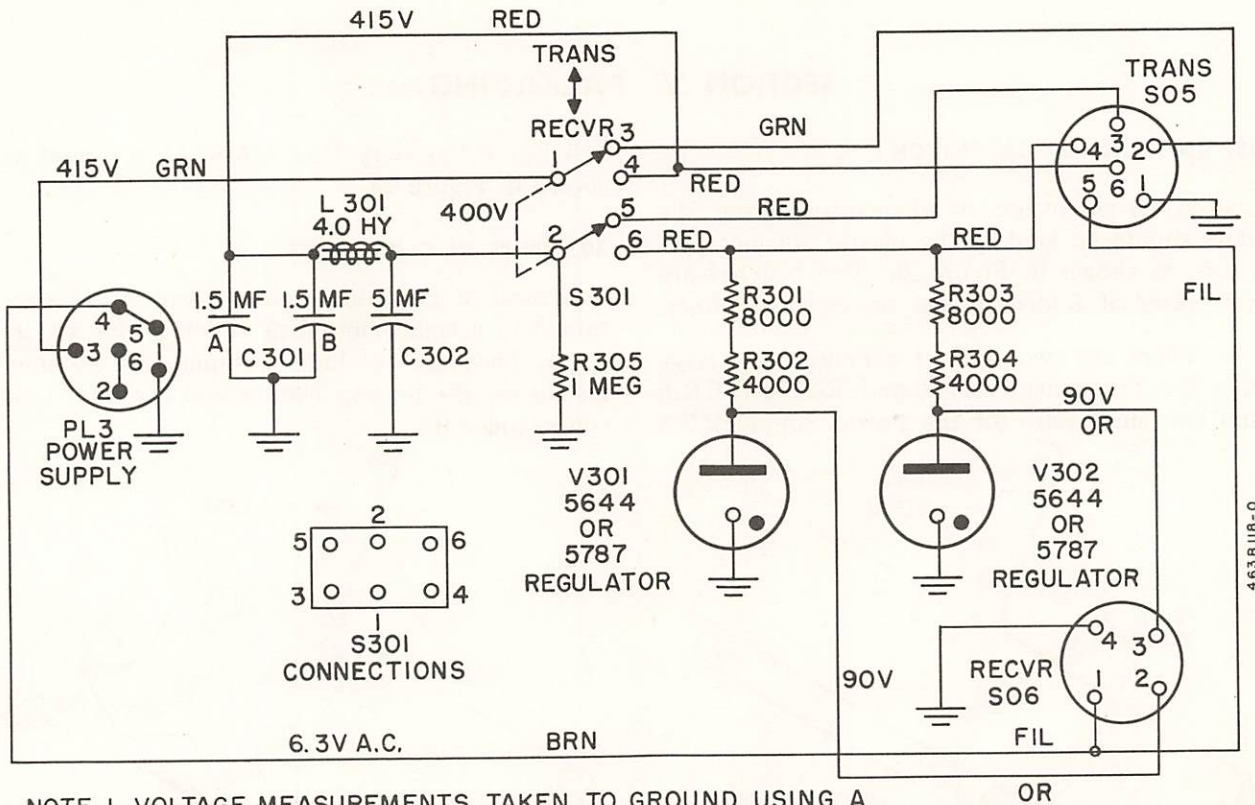

- NOTE 1. VOLTAGE MEASUREMENTS TAKEN TO GROUND USING A 20,000 OHM/VOLT METER AND ARE DC.
2. ALL PLUGS VIEWED FROM FRONT.
3. RESISTORS ARE IN OHMS UNLESS OTHERWISE SPECIFIED.

Figure 23. Filter-Accessory Unit RA-6, schematic diagram.

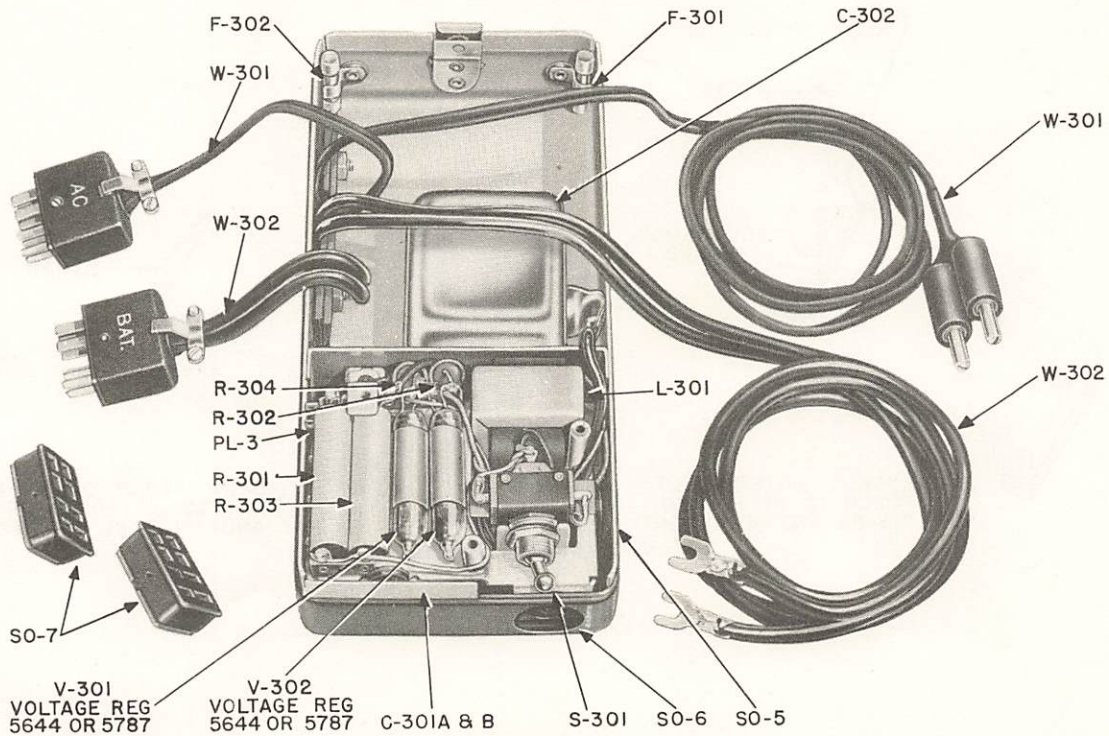

Figure 24. Filter-Accessory Unit RA-6, parts location.

## SECTION V. PACKAGING

### 38. UNITS IN PLASTIC POUCH

a. When not in use, or when transporting, the units should be kept in the plastic pouches provided, as shown in Figure 25. The pouches are waterproof if folded in the prescribed manner.

b. There are two sizes of pouches—two large ones for Transmitter RT-6 and Receiver RR-6 and two small ones for the Power Supply RP-6

and Filter-Accessory Unit RA-6. All are used as shown in Figure 25.

### 39. UNITS IN CLOTH BAG

Several of the additional accessories are contained in a small cloth bag which is not waterproof. They are the hank antenna, the antenna insulators, the battery clamps and the inter-unit connecting cord.

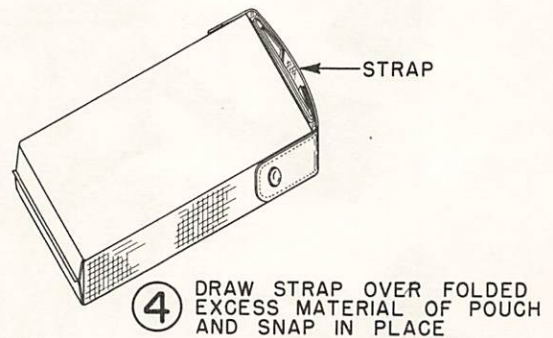
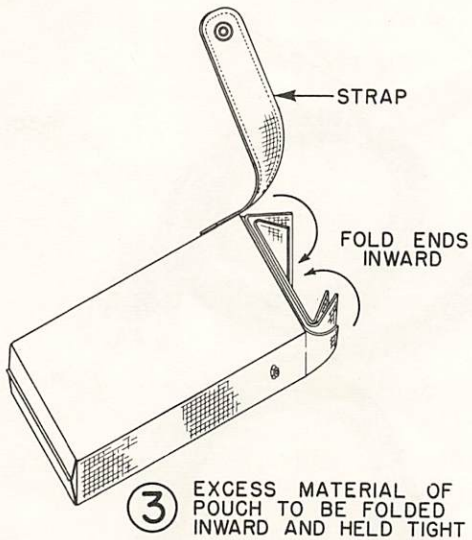
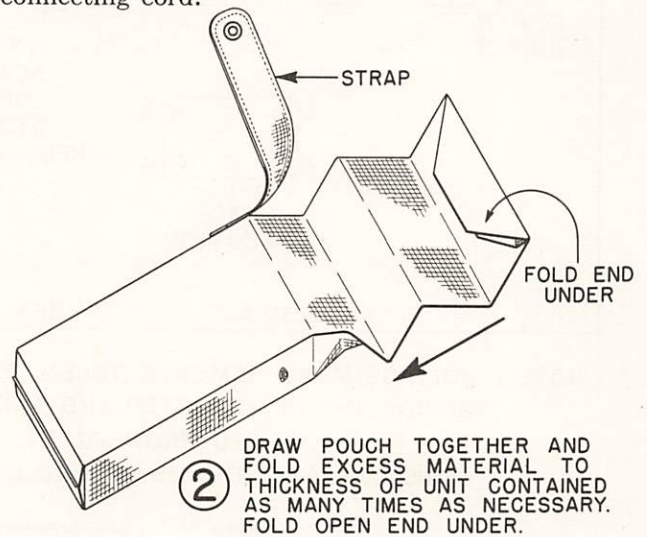
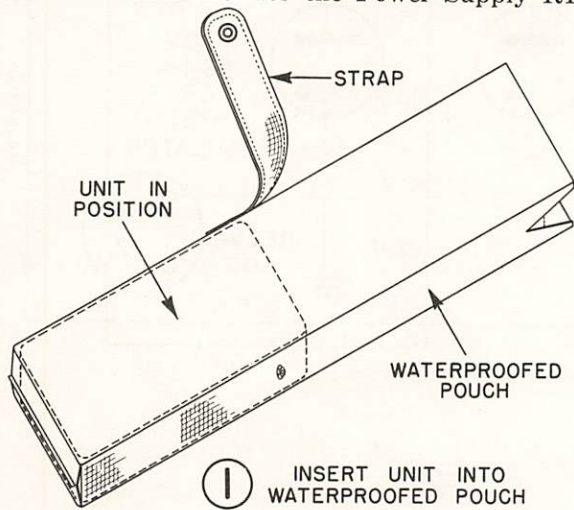

Figure 25. Packaging detail.

# CHAPTER 4

## REPLACEMENT PARTS LISTS

### SECTION I. RECEIVER RR-6

Ref. No.	Contractor's Drawing & Part Number	JAN Type	Description
C1	921R121	CC30SL470K	CAPACITOR, FIXED, CERAMIC DIELECTRIC: tubular type; 47 uuf $\pm 10\%$ ; 500 vdcw
C2	921R107	CC20SL220K	CAPACITOR, FIXED, CERAMIC DIELECTRIC: tubular type; 22 uuf $\pm 10\%$ ; 500 vdcw
C3	921R142		CAPACITOR, FIXED, CERAMIC DIELECTRIC: disc type; .001 uuf; 500 vdcw
C7	921R109	CC20SL270K	CAPACITOR, FIXED, CERAMIC DIELECTRIC: tubular type; 27 uuf $\pm 10\%$ ; 500 vdcw
C8	921R104	CC20SL150K	CAPACITOR, FIXED, CERAMIC DIELECTRIC: 15 uuf $\pm 10\%$ ; 500 vdcw
C9A, C9B, C9C	419D101		CAPACITOR, VARIABLE, AIR DIELECTRIC: plate meshing type; 3 sections; A & C—10 to 186 uuf; B—14 to 190 uuf; includes wormdrive
C10	419A103		CAPACITOR, VARIABLE, AIR DIELECTRIC: plate meshing type; 1.7 to 8.7 uuf
C11	419A103		CAPACITOR, VARIABLE, AIR DIELECTRIC: plate meshing type; 1.7 to 8.7 uuf
C12	921R152		CAPACITOR, FIXED, CERAMIC DIELECTRIC: disc type; .01 uuf $-20\%$ $+80\%$ ; 450 vdcw
C13	21R115042		CAPACITOR, FIXED, CERAMIC DIELECTRIC: tubular type; 100 uuf $\pm 5\%$ N220
C14	921R152		CAPACITOR, FIXED, CERAMIC DIELECTRIC: disc type; .01 uuf $-20\%$ $+80\%$ ; 450 vdcw
C15	921R152		CAPACITOR, FIXED, CERAMIC DIELECTRIC: disc type; .01 uuf $-20\%$ $+80\%$ ; 450 vdcw
C16	419A103		CAPACITOR, VARIABLE, AIR DIELECTRIC: plate meshing type; 1.7 to 8.7 uuf
C17	419A103		CAPACITOR, VARIABLE, AIR DIELECTRIC: plate meshing type; 1.7 to 8.7 uuf
C18	921R328	CM20D202J	CAPACITOR, FIXED, MICA DIELECTRIC: 2000 uuf $\pm 5\%$ ; 300 vdcw
C19	421A137		CAPACITOR, FIXED, CERAMIC DIELECTRIC: tubular type; 7.5 uuf $\pm 0.25$ uuf; 500 vdcw
C20	921R705		CAPACITOR, FIXED, MICA DIELECTRIC: 1000 uuf $\pm 5\%$ ; 500 vdcw
C21	421A137		CAPACITOR, FIXED, CERAMIC DIELECTRIC: tubular type; 7.5 uuf $\pm 0.25$ uuf; 500 vdcw

Ref. No.	Contractor's Drawing & Part Number	JAN Type	Description
C22	921R152		CAPACITOR, FIXED, CERAMIC DIELECTRIC: disc type; .01 uf -20% +80%; 450 vdew
C23	921R463	CC20CJ020C	CAPACITOR, FIXED, CERAMIC DIELECTRIC: tubular type; 2 uuf ±0.25 uuf; 500 vdew
C24	921R621	CC20CH010C	CAPACITOR, FIXED, CERAMIC DIELECTRIC: tubular type; 1 uuf ±0.25 uuf; 500 vdew
C25	921R101	CC20SL100K	CAPACITOR, FIXED, CERAMIC DIELECTRIC: tubular type; 10 uuf ±10%; 500 vdew
C26	419A103		CAPACITOR, VARIABLE, AIR DIELECTRIC: plate meshing type; 1.7 to 8.7 uuf
C27	921R622		CAPACITOR, FIXED, CERAMIC DIELECTRIC: tubular type; 8.2 uuf ±0.25 uuf; 500 vdew
C29	419A103		CAPACITOR, VARIABLE, AIR DIELECTRIC: plate meshing type; 1.7 to 8.7 uuf
C30	921R127	CC30SL101K	CAPACITOR, FIXED, CERAMIC DIELECTRIC: tubular type; 100 uuf ±10%; 500 vdew
C31	921R152		CAPACITOR, FIXED, CERAMIC DIELECTRIC: disc type; .01 uf -20% +80%; 450 vdew
C32	921R152		CAPACITOR, FIXED, CERAMIC DIELECTRIC: disc type; .01 uf -20% +80%; 450 vdew
C33	921R152		CAPACITOR, FIXED, CERAMIC DIELECTRIC: disc type; .01 uf -20% +80%; 450 vdew
C34	921R152		CAPACITOR, FIXED, CERAMIC DIELECTRIC: disc type; .01 uf -20% +80%; 450 vdew
C35	921R152		CAPACITOR, FIXED, CERAMIC DIELECTRIC: disc type; .01 uf -20% +80%; 450 vdew
C36	921R152		CAPACITOR, FIXED, CERAMIC DIELECTRIC: disc type; .01 uf -20% +80%; 450 vdew
C37	921R152		CAPACITOR, FIXED, CERAMIC DIELECTRIC: disc type; .01 uf -20% +80%; 450 vdew
C39	921R142		CAPACITOR, FIXED, CERAMIC DIELECTRIC: disc type; .001 uf 500 vdew
C40	921R123	CC30SL560K	CAPACITOR, FIXED, CERAMIC DIELECTRIC: tubular type; 56 uuf ±10%; 500 vdew
C41	921R152		CAPACITOR, FIXED, CERAMIC DIELECTRIC: disc type; .01 uf -20% +80%; 450 vdew
C43	921R152		CAPACITOR, FIXED, CERAMIC DIELECTRIC: disc type; .01 uf -20% +80%; 450 vdew
C44	921R152		CAPACITOR, FIXED, CERAMIC DIELECTRIC: disc type; .01 uf -20% +80%; 450 vdew

Ref. No.	Contractor's Drawing & Part Number	JAN Type	Description
C45	921R152		CAPACITOR, FIXED, CERAMIC DIELECTRIC: disc type; .01 uf -20% +80%; 450 vdew
C46	921R121	CC30SL470K	CAPACITOR, FIXED, CERAMIC DIELECTRIC: tubular type; 47 uuf ±10%; 500 vdew
C47	921R127	CC30SL101K	CAPACITOR, FIXED, CERAMIC DIELECTRIC: tubular type; 100 uuf ±10%; 500 vdew
C48	921R110	CC20SL330K	CAPACITOR, FIXED, CERAMIC DIELECTRIC: tubular type; 33 uuf ±10%; 500 vdew
C49	419B102		CAPACITOR, VARIABLE, AIR DIELECTRIC: plate meshing type; 1.7 to 8.7 uuf; special shorting type
C50	921R127	CC30SL101K	CAPACITOR, FIXED, CERAMIC DIELECTRIC: tubular type; 100 uuf ±10%; 500 vdew
C51	921R109	CC20SL270K	CAPACITOR, FIXED, CERAMIC DIELECTRIC: tubular type; 27 uuf ±10%; 500 vdew
C52	921R152		CAPACITOR, FIXED, CERAMIC DIELECTRIC: disc type; .01 uf -20% +80%; 450 vdew
C53	921R152		CAPACITOR, FIXED, CERAMIC DIELECTRIC: disc type; .01 uf -20% +80%; 450 vdew
CR1	448B104 or 448K105 or 448K106		CRYSTAL UNIT, RECTIFYING: germanium type; G.E. type IN48 CRYSTAL UNIT, RECTIFYING: germanium type; Kemtron type IN34 CRYSTAL UNIT, RECTIFYING: germanium type; Sylvania type IN34
I1	436B102		DIAL, BFO CONTROL
I2	436C101		DIAL, TUNING
I3	401V737		INDICATOR, FREQUENCY CHANNEL: with red and blue windows and rack gear
I4	401V484		KNOB ASSEMBLY, ADJUST CALIBRATION: with adjustment screw
I5	438B101		KNOB, RANGE SWITCH
I6	401V752		KNOB ASSEMBLY, VERNIER: complete with brackets, bushings, ten- sion spring, J2
J1	409C153		CONNECTOR, 2-PIN (Antenna and Ground)
J2	409K154		CONNECTOR, 2-PIN (Phones)
L1	424K138		COIL, RADIO FREQUENCY CHOKE: 220 uh
L2	424B164		COIL, RADIO FREQUENCY: 945 uh; tapped; adjustable iron core; beat frequency oscillator
PL6	428A104 or 401B518		CONNECTOR, PLUG: 4 male contacts; plug only CONNECTOR ASSEMBLY, PLUG: 4 male contacts; with cable
R1	906R526	RC20BF563K	RESISTOR, FIXED, COMPOSITION: 56,000 ohms ±10%; ½W; ins

Ref. No.	Contractor's Drawing & Part Number	JAN Type	Description
R2	906R445	RC20BF681K	RESISTOR, FIXED, COMPOSITION: 680 ohms $\pm 10\%$ ; $\frac{1}{2}W$ ; ins
R3	906R565	RC20BF474M	RESISTOR, FIXED, COMPOSITION: 470,000 ohms $\pm 20\%$ ; $\frac{1}{2}W$ ins;
R4	906R488	RC20BF682M	RESISTOR, FIXED, COMPOSITION: 6800 ohms $\pm 20\%$ ; $\frac{1}{2}W$ ; ins
R5	906R495	RC20BF103M	RESISTOR, FIXED, COMPOSITION: 10,000 ohms $\pm 20\%$ ; $\frac{1}{2}W$ ; ins
R6	906R414	RC20BF121K	RESISTOR, FIXED, COMPOSITION: 120 ohms $\pm 10\%$ ; $\frac{1}{2}W$ ; ins
R7	906R502	RC20BF153M	RESISTOR, FIXED, COMPOSITION: 15,000 ohms $\pm 20\%$ ; $\frac{1}{2}W$ ; ins
R8	906R488	RC20BF682M	RESISTOR, FIXED, COMPOSITION: 6800 ohms $\pm 20\%$ ; $\frac{1}{2}W$ ; ins
R9	906R600	RC20BF335M	RESISTOR, FIXED, COMPOSITION: 3.3 megohms $\pm 20\%$ ; $\frac{1}{2}W$ ; ins
R10	906R502	RC20BF153M	RESISTOR, FIXED, COMPOSITION: 15,000 ohms $\pm 20\%$ ; $\frac{1}{2}W$ ; ins
R11	906R495	RC20BF103M	RESISTOR, FIXED, COMPOSITION: 10,000 ohms $\pm 20\%$ ; $\frac{1}{2}W$ ; ins
R12	906R565	RC20BF474M	RESISTOR, FIXED, COMPOSITION: 470,000 ohms $\pm 20\%$ ; $\frac{1}{2}W$ ; ins
R13	906R470	RC20BF272K	RESISTOR, FIXED, COMPOSITION: 2700 ohms $\pm 10\%$ ; $\frac{1}{2}W$ ; ins
R14	906R526	RC20BF563K	RESISTOR, FIXED, COMPOSITION: 56,000 ohms $\pm 10\%$ ; $\frac{1}{2}W$ ; ins
R15	906R526	RC20BF563K	RESISTOR, FIXED, COMPOSITION: 56,000 ohms $\pm 10\%$ ; $\frac{1}{2}W$ ; ins
R16	906R488	RC20BF682M	RESISTOR, FIXED, COMPOSITION: 6800 ohms $\pm 20\%$ ; $\frac{1}{2}W$ ; ins
R17	906R565	RC20BF474M	RESISTOR, FIXED, COMPOSITION: 470,000 ohms $\pm 20\%$ ; $\frac{1}{2}W$ ; ins
R18	906R470	RC20BF272K	RESISTOR, FIXED, COMPOSITION: 2700 ohms $\pm 10\%$ ; $\frac{1}{2}W$ ; ins
R19	906R526	RC20BF563K	RESISTOR, FIXED, COMPOSITION: 56,000 ohms $\pm 10\%$ ; $\frac{1}{2}W$ ; ins
R20	906R526	RC20BF563K	RESISTOR, FIXED, COMPOSITION: 56,000 ohms $\pm 10\%$ ; $\frac{1}{2}W$ ; ins
R21	906R488	RC20BF682M	RESISTOR, FIXED, COMPOSITION: 6800 ohms $\pm 20\%$ ; $\frac{1}{2}W$ ; ins
R23	906R526	RC20BF563K	RESISTOR, FIXED, COMPOSITION: 56,000 ohms $\pm 10\%$ ; $\frac{1}{2}W$ ; ins
R25	906R526	RC20BF563K	RESISTOR, FIXED, COMPOSITION: 56,000 ohms $\pm 10\%$ ; $\frac{1}{2}W$ ; ins
R26	906R554	RC20BF274K	RESISTOR, FIXED, COMPOSITION: 270,000 ohms $\pm 10\%$ ; $\frac{1}{2}W$ ; ins
R27	906R431	RC20BF331K	RESISTOR, FIXED, COMPOSITION: 330 ohms $\pm 10\%$ ; $\frac{1}{2}W$ ; ins
R28	418B105		RESISTOR, VARIABLE, COMPOSITION: 1 megohm $\pm 20\%$ ; $1/10W$ ; includes knob
R29	906R488	RC20BF682M	RESISTOR, FIXED, COMPOSITION: 6800 ohms $\pm 20\%$ ; $\frac{1}{2}W$ ; ins
R30	906R554	RC20BF274K	RESISTOR, FIXED, COMPOSITION: 270,000 ohms $\pm 10\%$ ; $\frac{1}{2}W$ ; ins
R31	906R537	RC20BF104M	RESISTOR, FIXED, COMPOSITION: 100,000 ohms $\pm 20\%$ ; $\frac{1}{2}W$ ; ins
R32	906R495	RC20BF103M	RESISTOR, FIXED, COMPOSITION: 10,000 ohms $\pm 20\%$ ; $\frac{1}{2}W$ ; ins
R33	906R565	RC20BF474M	RESISTOR, FIXED, COMPOSITION: 470,000 ohms $\pm 20\%$ ; $\frac{1}{2}W$ ; ins

Ref. No.	Contractor's Drawing & Part Number	JAN Type	Description
R34	906R540	RC20BF124K	RESISTOR, FIXED, COMPOSITION: 120,000 ohms $\pm 10\%$ ; $\frac{1}{2}W$ ; ins
S1	440C102		SWITCH, SLIDE: range switch; with knob
S2	440A103		SWITCH, PUSH: single-pole, single-throw; momentary contact; normally open
T1	424B162		TRANSFORMER, RADIO FREQUENCY: adjustable iron core; LF antenna
T2	424B163		TRANSFORMER, RADIO FREQUENCY: adjustable iron core; HF antenna
T3	424B158		TRANSFORMER, RADIO FREQUENCY: adjustable iron core; LF RF
T4	424B159		TRANSFORMER, RADIO FREQUENCY: adjustable iron core; HF RF
T5	424B160		TRANSFORMER, RADIO FREQUENCY: adjustable iron core; LF Osc
T6	424B161		TRANSFORMER, RADIO FREQUENCY: adjustable iron core; HF Osc
T7	424B121		TRANSFORMER, INTERMEDIATE FREQUENCY: 455 kc; input; iron core; double-tuned; with shield
T8	424B121		TRANSFORMER, INTERMEDIATE FREQUENCY: 455 kc; interstage; iron core; double-tuned; with shield
T9	424B121		TRANSFORMER, INTERMEDIATE FREQUENCY: 455 kc; output; iron core; double-tuned; with shield
T10	425B121		TRANSFORMER, AUDIO FREQUENCY: plate-to-phone coupling type
V1			ELECTRON TUBE: subminiature pentode; 8 term wire type; RMA type 5899
V2			ELECTRON TUBE: subminiature pentode; 8 term wire type; RMA type 5899
V3			ELECTRON TUBE: subminiature pentode; 8 term wire type; RMA type 5899
V4			ELECTRON TUBE: subminiature pentode; 8 term wire type; RMA type 5899
V5			ELECTRON TUBE: subminiature pentode; 8 term wire type; RMA type 5899
V6			ELECTRON TUBE: subminiature triode; 8 term wire type; RMA type 5718
V7			ELECTRON TUBE: subminiature triode; 8 term wire type; RMA type 5718
V8			ELECTRON TUBE: subminiature triode; 8 term wire type; RMA type 5718
X1	409B118		SOCKET, CRYSTAL: with switch
Y1			CRYSTAL UNIT, QUARTZ: plug-in type (not furnished with receiver)
Y2	448A103		CRYSTAL UNIT, QUARTZ: 500 kc

## SECTION II. TRANSMITTER RT-6

Ref. No.	Contractor's Drawing & Part Number	JAN Type	Description
C101	408A102		CAPACITOR, FIXED, METALLIZED PAPER: 1 uf $\pm 20\%$ ; 200 vdew
C102	921R110	CC20SL330K	CAPACITOR, FIXED, CERAMIC DIELECTRIC: tubular type; 33 uuf $\pm 10\%$ ; 500 vdew
C103	921R142		CAPACITOR, FIXED, CERAMIC DIELECTRIC: disc type; .001 uf; 500 vdew
C104	921R127	CC30SL101K	CAPACITOR, FIXED, CERAMIC DIELECTRIC: tubular type; 100 uuf $\pm 10\%$ ; 500 vdew
C105	419B121		CAPACITOR, VARIABLE, AIR DIELECTRIC: plate meshing type; 7.5 uuf to 176 uuf
C106	921R152		CAPACITOR, FIXED, CERAMIC DIELECTRIC: disc type; .01 uf $-20\%$ $+80\%$ ; 450 vdew
C107	921R107	CC20SL220K	CAPACITOR, FIXED, CERAMIC DIELECTRIC: tubular type; 22 uuf $\pm 10\%$ ; 500 vdew
C108	921R152		CAPACITOR, FIXED, CERAMIC DIELECTRIC: disc type; .01 uf $-20\%$ $+80\%$ ; 450 vdew
C109	921R152		CAPACITOR, FIXED, CERAMIC DIELECTRIC: disc type; .01 uf $-20\%$ $+80\%$ ; 450 vdew
C110	921R152		CAPACITOR, FIXED, CERAMIC DIELECTRIC: disc type; .01 uf $-20\%$ $+80\%$ ; 450 vdew
C111	921R152		CAPACITOR, FIXED, CERAMIC DIELECTRIC: disc type; .01 uf $-20\%$ $+80\%$ ; 450 vdew
C112	419B104		CAPACITOR, VARIABLE, AIR DIELECTRIC: plate meshing type; 11 uuf to 218 uuf
C114	921R142		CAPACITOR, FIXED, CERAMIC DIELECTRIC: disc type; .001 uf; 500 vdew
C115	921R152		CAPACITOR, FIXED, CERAMIC DIELECTRIC: disc type; .01 uf $-20\%$ $+80\%$ ; 450 vdew
C116	423A104		CAPACITOR, FIXED, ELECTROLYTIC: Aerovox type SREN; 5 uf; 150 vdew
E101	465A121		LAMP, GLOW: neon; $\frac{1}{4}W$ ; ionizing potential 47-55v rms (contractor's color code red or blue)
E102	465A121		LAMP, GLOW: neon; $\frac{1}{4}W$ ; ionizing potential 47-55v rms (contractor's color code red or blue)
E103	465A113		LAMP, INCANDESCENT: G.E. type 49; 2v; .06 amp; tubular; clear glass; bayonet base
E104	465A121		LAMP, GLOW: neon; $\frac{1}{4}W$ ; ionizing potential 47-69v rms (contractor's color code red, blue or yellow)
I101	436B125		KNOB; ANT IMPEDANCE MATCHING SWITCH

Ref. No.	Contractor's Drawing & Part Number	JAN Type	Description
I102	436B156		KNOB; FINAL AMP TUNING
I103	436B127		KNOB; OSC TUNING
J101	409A158		JACK, TELEPHONE, THREE CIRCUIT: accommodates 2-conductor Army plug PL55
J102	409K154		CONNECTOR, 2-pin (Antenna and Ground)
J103	409C153		CONNECTOR, 2-pin (Rec Ant and Monitor)
K101	459C112		RELAY, KEYING, DPDT: switches antenna and B power
L101	424A128		COIL, RADIO FREQUENCY: plate tank; 16.4 uh
L102	424A143		COIL, RADIO FREQUENCY CHOKE
L103	424A155		COIL, RADIO FREQUENCY CHOKE: 100 uh
L104	424B204		COIL, RADIO FREQUENCY: HF plate tank; 5 taps
L105	424B202		COIL, RADIO FREQUENCY: LF plate tank; 5 taps
L106	424B201		COIL, RADIO FREQUENCY CHOKE: 100 uh
LR101	424A156		COIL, RADIO FREQUENCY: 80 uh; wound on 560-ohm $\pm 10\%$ $\frac{1}{2}W$ fixed composition resistor
PL5	428A122		CONNECTOR, PLUG: 6 male contacts
R101	906R536	RC20BF104K	RESISTOR, FIXED, COMPOSITION: 100,000 ohms $\pm 10\%$ ; $\frac{1}{2}W$ ; ins
R102	906R529	RC20BF683K	RESISTOR, FIXED, COMPOSITION: 68,000 ohms $\pm 10\%$ ; $\frac{1}{2}W$ ; ins
R104	906R547	RC20BF184K	RESISTOR, FIXED, COMPOSITION: 180,000 ohms $\pm 10\%$ ; $\frac{1}{2}W$ ; ins
R105	906R781	RC30BF333K	RESISTOR, FIXED, COMPOSITION: 33,000 ohms $\pm 10\%$ ; 1W; ins
R106	906R585	RC20BF155K	RESISTOR, FIXED, COMPOSITION: 1.5 megohms $\pm 10\%$ ; $\frac{1}{2}W$ ; ins
R107	906R778	RC30BF273K	RESISTOR, FIXED, COMPOSITION: 27,000 ohms $\pm 10\%$ ; 1W; ins
R108	906R960	RC42BE271K	RESISTOR, FIXED, COMPOSITION: 270 ohms $\pm 10\%$ ; 2W; ins
R109	906R1044	RC42BE273K	RESISTOR, FIXED, COMPOSITION: 27,000 ohms $\pm 10\%$ ; $\frac{1}{2}W$ ; ins
R110	906R372	RC20BF120K	RESISTOR, FIXED, COMPOSITION: 12 ohms $\pm 10\%$ ; $\frac{1}{2}W$ ; ins
R111	906R620	RC20BF106K	RESISTOR, FIXED, COMPOSITION: 10 megohms $\pm 10\%$ ; $\frac{1}{2}W$ ; ins
R112	906R988	RC42BE122K	RESISTOR, FIXED, COMPOSITION: 1,200 ohms $\pm 10\%$ ; 2W; ins
S101	440A123		SWITCH, SLIDE: single-pole, double-throw
S102	440A122		SWITCH, SLIDE: double-pole, double-throw
S103	440B104		SWITCH, ROTARY: special; 5-position with OFF; 2 poles
S104	401V724		KEY ASSEMBLY, TRANSMITTER

Ref. No.	Contractor's Drawing & Part Number	JAN Type	Description
V101	409A131		ELECTRON TUBE: miniature pentode; 7 pins; RMA type 6AG5
V102			ELECTRON TUBE: pentode; octal; pin type; RMA type 2E26
X101			SOCKET, CRYSTAL
Y101			CRYSTAL UNIT, QUARTZ (not furnished with transmitter)

### SECTION III. POWER SUPPLY RP-6

Ref. No.	Contractor's Drawing & Part Number	JAN Type	Description
C201	408A123		CAPACITOR, FIXED, PAPER DIELECTRIC: .006 uf 1600 vdcw
C202	408A123		CAPACITOR, FIXED, PAPER DIELECTRIC: .006 uf 1600 vdcw
C203	408A121		CAPACITOR, FIXED, PAPER DIELECTRIC: .5 uf 200 vdcw
C204	921R152		CAPACITOR, FIXED, CERAMIC DIELECTRIC: disc type; .01 uf -20% +80%; 450 vdcw
C205	408K107		CAPACITOR, FIXED, CERAMIC DIELECTRIC: disc type; .5 uf -20% +80%; 200 vdcw
C206	921R152		CAPACITOR, FIXED, CERAMIC DIELECTRIC: disc type; .01 uf -20% +80%; 450 vdcw
CR201	448C123		RECTIFIER, METALLIC: selenium, full-wave
E201	465A121		LAMP, GLOW: neon; ¼W; ionizing potential 53-55V rms (contractor's color code red)
F201	465A111		FUSE, GLASS TUBULAR: 1.5 amperes; 250V
F202	465K112		FUSE, GLASS TUBULAR: 15 amperes; 32V
G201	448B101		VIBRATOR, NON-SYNCHRONOUS: 115 cps, 6 vdc
I201	436B101		KNOB, LINE VOLTAGE SELECTOR: permanently glued to shaft of S-201
L201	424A157		COIL, RADIO FREQUENCY CHOKE: 6.0 uh
L202			COIL, RADIO FREQUENCY CHOKE: not replaceable—formed by lead wire
R201	906R535	RC20BF104J	RESISTOR, FIXED, COMPOSITION: 100,000 ohms ±5%; ½W; ins
R202	906R535	RC20BF104J	RESISTOR, FIXED, COMPOSITION: 100,000 ohms ±5%; ½W; ins
R203	906R400	RC20BF560	RESISTOR, FIXED, COMPOSITION: 56 ohms ±10%; ½W; ins
R204	906R400	RC20BF560K	RESISTOR, FIXED, COMPOSITION: 56 ohms ±10%; ½W; ins
S201	440B108		SWITCH, ROTARY: 8-position; single-pole; shorting type. Knob I201 must be broken to remove S201
S01, S02	409B121		CONNECTOR ASSEMBLY: consists of two Jones receptacles, one 8-prong (S01) and one 7-prong (S02)

Ref. No.	Contractor's Drawing & Part Number	JAN Type	Description
S03	409A122		CONNECTOR, PLUG: 6 female contacts
T201	425D137		TRANSFORMER, POWER
V201			ELECTRON TUBE: miniature double diode; RMA type 6X4

#### SECTION IV. FILTER-ACCESSORY UNIT RA-6

Ref. No.	Contractor's Drawing & Part Number	JAN Type	Description
C301A, C301B	408B122		CAPACITOR, FIXED, PAPER DIELECTRIC: 2-section; 1.5 x 1.5 uf 600 vdcw
C302	408B106		CAPACITOR, FIXED, PAPER DIELECTRIC: 5 uf; 600 vdcw
F301	465A111		FUSE, GLASS TUBULAR: 1.5-ampere, 250V. Spare for F201
F302	465K112		FUSE, GLASS TUBULAR: 15-ampere, 32V. Spare for F202
HS301	450B101		RECEIVER, EARSET: magnetic type; 2000 ohms impedance; with 2- terminal receptacle
L301	401V375		REACTOR: filter choke; single winding; 4 hy; includes mtg nuts
O301 O302 O303	442A162		RING, RETAINER (SO6, SO5 and PL3)
PL3	428A123		CONNECTOR, PLUG: 6 male contacts
R301	418K128		RESISTOR, FIXED, WIREWOUND: 8000 ohms $\pm 5\%$ ; 10W
R302	418A127		RESISTOR, FIXED, WIREWOUND: 4000 ohms $\pm 5\%$ ; 5W
R303	418K128		RESISTOR, FIXED, WIREWOUND: 8000 ohms $\pm 5\%$ ; 10W
R304	418A127		RESISTOR, FIXED, WIREWOUND: 4000 ohms $\pm 5\%$ ; 5W
R305	906R578	RC20BF105K	RESISTOR, FIXED, COMPOSITION: 1 megohm $\pm 10\%$ ; $\frac{1}{2}$ W; ins
S301	440A110 or 440K111		SWITCH, TOGGLE: double-pole, double-throw; 3-amp, 250V
SO5	409A128		CONNECTOR, PLUG: 6 female contacts
SO6	409A129		CONNECTOR, PLUG; 4 female contacts
SO7	409A157		SOCKET, PROTECTIVE (TWO): used to prevent damage to pins of plugs W301 and W302
V301			ELECTRON TUBE: sub-miniature voltage regulator; JAN type 5644
		or	ELECTRON TUBE: sub-miniature voltage regulator; JAN type 5787
V302			ELECTRON TUBE: sub-miniature voltage regulator; JAN type 5644
		or	ELECTRON TUBE: sub-miniature voltage regulator; JAN type 5787

Ref. No.	Contractor's Drawing & Part Number	JAN Type	Description
W301	401B363		CABLE ASSEMBLY, AC: 2-conductor; with universal line plug and Jones plug; 6 ft long
W302	401B366		CABLE ASSEMBLY, BATTERY: 2-conductor; one red, one black; with spade lugs and Jones plug; 41 in. long
W303	430B101		CORD, EARSET: 5 ft long; 2-conductor; with two .083 tips and 2-prong male plug
W305	464B274		PLATES, schematics (comp)

#### SECTION V. ADDITIONAL ACCESSORIES

Ref. No.	Contractor's Drawing & Part Number	JAN Type	Description
E301	451B101		HANK, antenna (100 ft)
E302	414A117		INSULATORS, antenna (two)
E303	465A113		LAMP, INCANDESCENT, G.E. TYPE 49: 2v; .06 amp; tubular; clear glass; bayonet base. Spare for E103
H301	401V376		CLAMPS, battery; with screw (two)
W304	430B143		CORD, INTER-UNIT: consists of two twisted leads, with three Lenz type #550 connectors and one MUELLER #45 battery clip. To connect side-tone and antenna to receiver.

## APPENDIX I. LOW RANGE OHMMETER

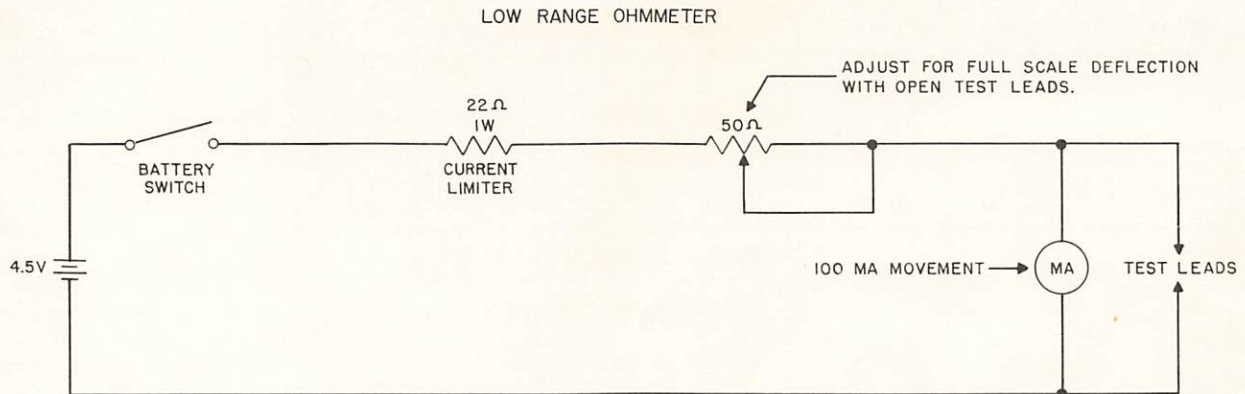

- NOTE 1. BATTERY CONSISTS OF THREE 1.5V FLASHLIGHT CELLS IN SERIES.  
 NOTE 2. USE HEAVY GAUGE, SHORT TEST LEADS FOR MINIMUM LEAD RESISTANCE.  
 NOTE 3. NOTE RESISTANCE OF SHORTED TEST LEADS & SUBTRACT THIS AMOUNT FROM ALL SUBSEQUENT READINGS AS A CORRECTION FACTOR.  
 NOTE 4. OPEN SWITCH WHEN NOT IN USE TO PREVENT UNNECESSARY CURRENT DRAIN ON BATTERY.  
 NOTE 5. READINGS IN THE METER CALIBRATION TABLE ARE FOR THE ABOVE CIRCUIT ONLY. IF THE CIRCUIT IS ALTERED THE FORMULA MAY NOT APPLY.  
 NOTE 6. TO DETERMINE RESISTANCE VALUES NOT LISTED IN TABLE USE THE FOLLOWING FORMULA:

$$R_{\text{MEASURED}} = \left( \frac{I_M}{100 - I_M} \right) R_M$$

WHERE:

$I_M$  = METER READING

$R_M$  = INTERNAL RESISTANCE OF METER

EXAMPLE:  
WHEN METER READING IS 3 MA

$$R_{\text{MEASURED}} = \left( \frac{3}{100 - 3} \right) \cdot 1$$

$$R_{\text{MEASURED}} = .03 \text{ OHM}$$

METER CALIBRATION TABLE \*

METER READING (MA)	RESISTANCE (OHMS)
0	0
5	.052
10	.11
20	.25
30	.42
40	.66
50	1.0
60	1.5
70	2.3
80	4.0
90	9.0
100	$\infty$

\* VALUES CALCULATED FOR METER WITH 1 OHM INTERNAL RESISTANCE. (WESTON MODEL 301)

Figure 26. Low range ohmmeter.

MEMO