

copyrighted 1968 by Allied Radio Corp. / printed in U.S.A.



AMATEUR COMMUNICATIONS RECEIVER 83 YU 726

ASSEMBLY MANUAL

knight-kit

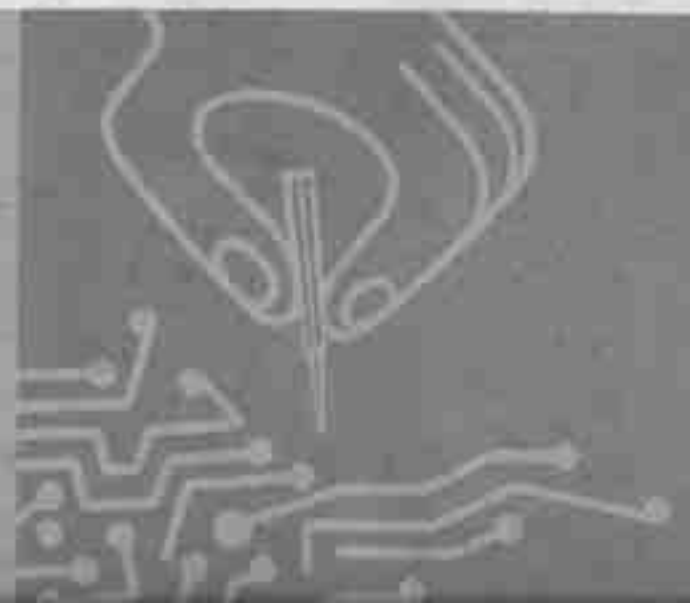

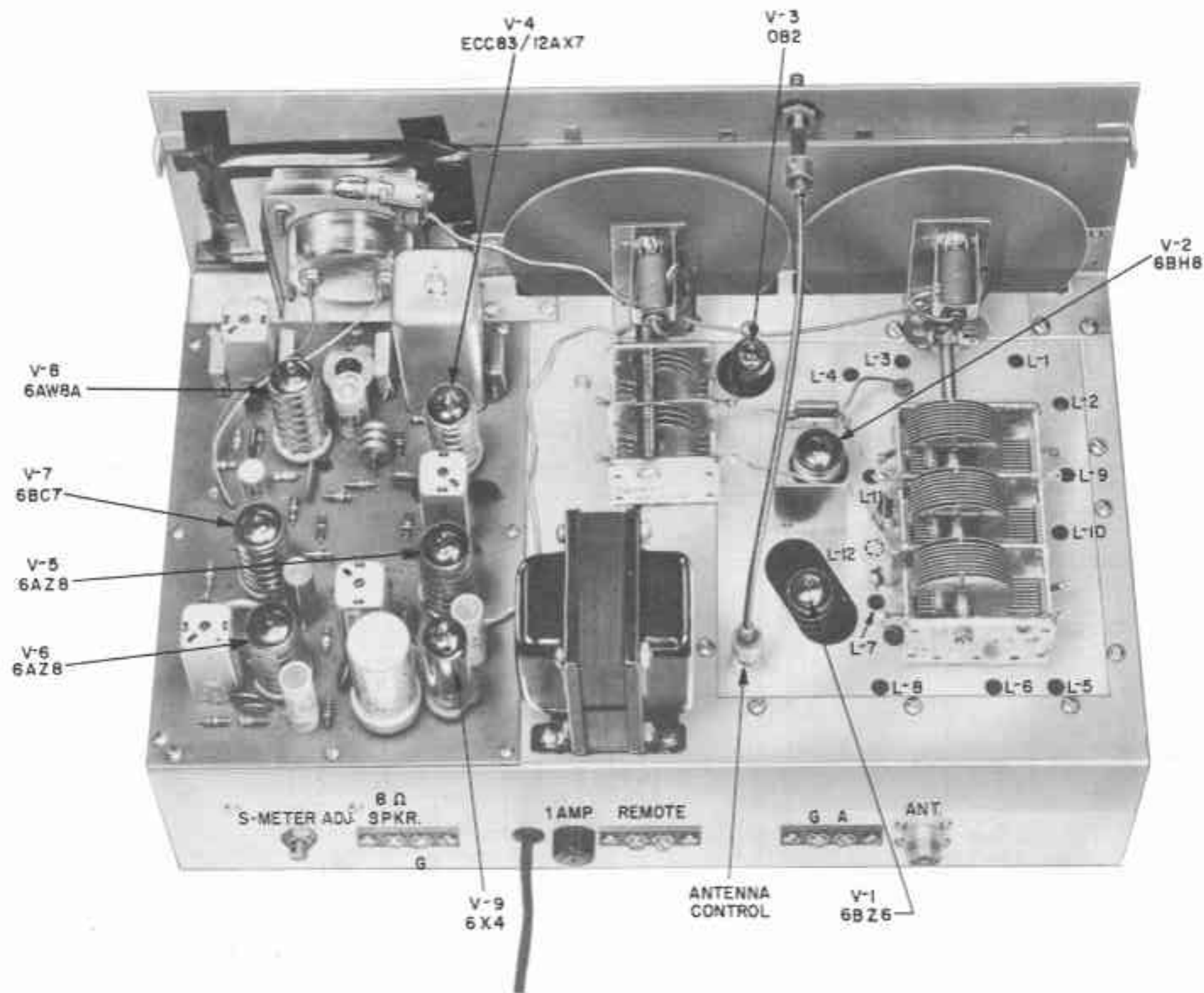

EQUIPMENT USED FOR SPECIFICATION MEASUREMENTS

Simpson Model 390 Wattmeter Hewlett-Packard Model 400D AC VTVM

Simpson Model 260 VOM Tektronix Model 531 Oscilloscope

Triplett Model 630A VOM Measurements Corp. Model 65B RF Generator

Frequency Standard BC 221

AMATEUR COMMUNICATIONS RECEIVER

SPECIFICATIONS

FREQUENCY RANGE	BAND A .54—1.65 mc BAND B 1.6 —4.6 mc BAND C 4.4 —12.4 mc BAND D 12 —30 mc	POWER CONSUMPTION	45 Watts at 117 V AC, 60 cps	
CALIBRATED BANDSPREAD	80 meters 3.5— 4 mc 40 meters 6.9— 7.3 mc 20 meters 14.0—14.4 mc 15 meters 20.5—21.5 mc 10 meters 26.6—30 mc	BEAT FREQUENCY	Varies from zero beat to 5 kc	
CALIBRATION ACCURACY	0.7% Max. deviation MAIN TUNING 0.15% Max. deviation BANDSPREAD	IF FREQUENCY	455 kc	
MAXIMUM AUDIO OUTPUT	.5 Watt	HFO FREQUENCY	455 kc higher than incoming signal on Band A, B and C. Lower than incoming signal by 455 kc on Band D	
AUDIO OUTPUT IMPEDANCE	8Ω	IMAGE REJECTION RATIO	Low end	High end
AVC	Delayed action over —2.0 V bias	Band A	80 db	40 db
VARIABLE SELECTIVITY	300 cps — 4.5 kc (6 db down) Up to 60 db null and 70 db peak	Band B	68 db	40 db
SENSITIVITY	1.5 μV or better at 10:1 signal to noise ratio on Band B, C and D 4 μV or better on Band A	Band C	30 db	25 db
ANTENNA INPUT IMPEDANCES	Low impedance coaxial or twin-line	Band D	40 db	20 db
		DIMENSIONS	10 x 16 x 10¾"	
		NET WEIGHT	25 lbs.	
		TUBE COMPLEMENT	6BZ6 (RF Amp); 6BH8 (Mixer and HFO); 6AZ8 (1st IF Amp); 6AZ8 (2nd IF Amp); 6BC7 (Detector-AVC-ANL); 6AW8A (BFO and Power Amp); ECC83/12AX7 (Q Multiplier); 6X4 (Full wave rectifier); OB2 (Voltage regulator).	

See page 45 for equipment used for specifications measurements.

FEATURES

PRINTED CIRCUITS USED IN RF, IF AND AUDIO STAGES

PRINTED CIRCUIT BANDSWITCH

MULTI-PURPOSE TUBES PROVIDE ELEVEN-TUBE PERFORMANCE

CONSTANT RUNNING HFO, WITH VOLTAGE-REGULATED B+ SUPPLY

BUILT-IN Q-MULTIPLIER PEAKS DESIRED SIGNAL OR NULLS INTERFERENCE

VARIABLE SELECTIVITY THROUGHOUT IF PASSBAND

DELAYED AVC ACTION

AUTOMATIC NOISE LIMITER

PROVISION FOR REMOTE-CONTROLLED STANDBY-RECEIVE

PROVISION FOR ADDITION OF S-METER AND CRYSTAL CALIBRATOR

TWO ANTENNA INPUTS—FOR COAX OR TWIN LINE

DELUXE, MODERN DESIGN—WELL VENTILATED CABINET—RUGGED CHASSIS

INTRODUCTION

The Amateur Communications Receiver is a precision-engineered instrument designed to meet the high standards of Amateur performance. It offers widely adjustable selectivity and exceptionally high sensitivity to bring in solid QSO's. The frequency range covers standard, medium, and short-wave broadcasts, including all Amateur bands from 80 through 10 meters. By using multi-purpose tubes, the 7-tube superheterodyne circuit provides performance equal to an 11-tube receiver.

To simplify the tuning of the crowded shortwave stations, the receiver uses a separate bandspread tuning capacitor. It is calibrated for the five Amateur bands (80-10 meters), and is also helpful for bandspread tuning any part of the frequency spectrum. The main tuning dial covers 540 kc to 31 mc in 4 ranges. The civil defense frequencies are clearly marked, and each Amateur band is indexed. Both main and bandspread dials have vernier mechanisms for smooth, easy tuning.

Other features are a highly effective noise limiter and a built-in Q-Multiplier to peak desired signals or to null undesired signals and interference. A constant-running high-frequency oscillator with voltage-regulated B+ supply, and extra-heavy chassis design contribute to the rock-like stability of this fine receiver. Frequency stability is maintained over a wide temperature range.

Two printed circuit boards assure wiring accuracy and uniformly high performance of every receiver kit. All critical wiring is already done—there is no problem of lead dress. Assembly has been further simplified by use of a unique printed-circuit bandswitch.

CHECKING YOUR KIT

Before starting to build your receiver, check each part against the parts list on pages 41, 42 and 43. This will help you become acquainted with each part. If you are unable to identify some parts by sight, locate their pictures on the wiring diagrams.

Symbols are used to describe parts. The Greek letter " μ " means micro, " Ω " means ohm, "K" means one thousand, "m" means milli (or one-thousandth), "M" means meg (one million), and "h" means henry.

The resistors are marked with four color bands. The first three bands designate the value of the resistor in ohms, and the fourth color band specifies the tolerance of the resistor. As an example, a 150 Ω resistor would be marked brown, green, brown, silver. There is one resistor in which the third color band is gold—this resistor is a 3.3 Ω resistor.

CONSTRUCTION AND WIRING HINTS

The only tools necessary for building your receiver are: A pair of long-nose pliers, diagonal cutting pliers, a screwdriver and a soldering iron.

Study the pictorial diagrams and note how the parts are mounted. These pictorial diagrams show the actual location of all parts and wires. The schematic diagram shows how the parts are connected electrically and is helpful in understanding how the receiver works.

Be sure to follow the step-by-step instructions exactly. DO NOT wire this kit from the pictorials or schematic alone as it must be assembled and wired in a definite sequence. Occasionally, several parts are mounted with the same hardware, so be sure that you read each step all the way through before you do it.

Space is provided, for your convenience, to check off each step after you have completed it.

When connecting wires to a terminal (holes are used on the printed circuit board), bend the end of the wire around the terminal and clamp it tightly with long-nose pliers. This assures a good mechanical connection. Solder must not be used to supply mechanical strength—its only purpose is to assure a good electrical connection between two conductors.

To connect a component to a terminal strip, pull the end lead of the part being mounted through the holes in the mounting terminals so that the part is tightly mounted. After the part is mounted, bend its leads around the mounting terminals and cut off the excess wire. Leads on the chokes, output transformer, resistors and capacitors, are usually longer than needed. These leads should be cut to the proper length when the parts are wired in place. Remove whatever type of insulation has been used. If enamel-coated, scrape the enamel off. Coat the newly exposed wire with a thin coat of solder, and then connect it to the specified terminal.

There are three kinds of insulated wire supplied with this kit: Shielded stranded wire; ordinary stranded wire; and solid wire. The solid wire has already been cut to length and the ends stripped to save you time. Each solid wire of a different color has a definite length. When a solid wire is to be used, only the color is specified. This automatically assures the correct length. The only exception, an 8" red, stranded wire, will be specified.

A piece of bare wire is included. Whenever it is necessary to use some of the bare wire, the exact length to be used is specified.

When you position the insulated wires, be careful that the insulation does not rub over a bare metal edge, and that the insulation is not pinched across a metal edge. This may cause the insulation to wear through and result in a short.

When wiring the contacts of the switches, be careful not to bend the switch contacts. Bending would reduce the spring tension of the contacts.

The soft tubing supplied is called "spaghetti". Spaghetti is used to cover the bare leads of some of the parts. Whenever it is necessary to use some of this spaghetti, the exact length is given. The spaghetti must cover the entire lead where there is a chance that the bare wire would touch another lead, a connection, or the chassis.

Follow the pictorial diagrams closely. This unit will work best with components and wires positioned as shown.

PRINTED CIRCUITS

Printed circuits are used throughout your receiver, including the band-switch. These printed circuits greatly simplify the wiring. A printed circuit is basically a pattern of conducting material on an insulating support. The conducting material is usually copper and the insulator is usually laminated plastic. The insulator sheet is first covered with a thin layer of copper foil. To form the wiring, some of the copper foil is removed by a photographic and etching process. Holes are then drilled in the board through which the leads of the various parts are inserted. The components are soldered directly to the wiring pattern. The result is a circuit with uniform wiring, compact size, and free from wiring errors.

Inspect both of the printed circuit boards carefully. You will notice that the boards have two different sides—a component side which has an outline of the parts layout printed on it, and a metal foil side which has the wiring pattern etched on it.

Hold the board so the component side of the board is toward you. The holes in the board are spaced to accept the leads from the parts to be mounted. Bend the part leads sharply, close to the body of the part. Insert the leads through the holes in the board and bend them over on the other side, to hold the part in place. Mount all parts on the component side of the board, unless otherwise specified.

It is important that the capacitors with a "+" sign are installed as shown. This maintains the proper polarity of these capacitors.

PRINTED CIRCUIT WIRING

Soldering a printed circuit is easy if a few rules are carefully followed. Avoid applying too much heat or not enough heat to the work. For most electronics work, a soldering iron rated at 100 watts, with a small tip, should be used.

Not enough heat from the iron will result in a poor connection or no connection at all. (This is the most common trouble for beginners.)

Avoid using too much solder. In some areas on the printed circuit board, the wiring is closely spaced. Too much solder may cause a short circuit or intermittent trouble.

HOW TO CARE FOR YOUR SOLDERING IRON

Your soldering iron is the key to good soldering since it supplies the essential ingredient—HEAT. If the tip is covered by a dirt (oxide) film, the iron will not be able to transfer its full heat. A new tip can be protected from film by coating it with solder the first time it is heated. An old copper tip should first be cleaned with a file until bare copper is exposed. Then solder-coat it like a new tip.

Never use the iron like a brush—soldering is not a paste-spreading operation. To get the most heat from the iron, always press the iron firmly to the connection. Hold it so the greatest tip surface is directly in contact with the connection.

THIS KIT MUST BE PROPERLY SOLDERED!

WITHOUT GOOD SOLDERING, AN ELECTRONIC UNIT WILL NOT WORK . . . just as a suit of clothing will fall apart if the stitches are loose . . . no matter how excellent the material.

USE ENOUGH HEAT

This is the main idea of good soldering. The purpose of soldering is to join metal parts, making an UNBROKEN metal path over which electricity can travel. To do this you must apply enough heat to the metal surfaces to make the solder spread freely on them, until the contour (shape) of the connection shows under the solder. If the solder barely melts and forms a rounded ball, *you are not using enough heat*. If you do not use enough heat, there may be no electrical connection, although it appears soldered.

HERE'S HOW TO DO IT . . .

1. Join bare metal to bare metal. Insulation must be removed.
2. Coat the tip of a hot iron with solder.
3. FIRMLY PRESS THE FLAT SIDE OF THE TIP OF A HOT IRON FLAT against the parts to be soldered together. Keep it there while you apply the solder BETWEEN THE IRON TIP AND THE METAL TO BE SOLDERED. Use only enough solder for it to flow over ALL the surfaces of the connection. Remove the iron.
4. DO NOT MOVE PARTS UNTIL THE SOLDER HARDENS. If you accidentally move the wires as the solder is hardening, apply your iron and reheat.

Compare your soldering with the pictures on this page. You have a good connection if your solder has flowed over all surfaces to be connected, following the shape of the surfaces. It should appear smooth and bright.

YOU HAVE NOT USED ENOUGH HEAT: If your connection is rough and flaky-looking, or if the solder has formed a round ball instead of spreading.

The difference between good soldering (enough heat) and poor soldering (not enough heat,) is just a few extra seconds with a hot iron FIRMLY applied. Remember, larger metal surfaces take a longer time to heat.

USE A 100-WATT IRON

A 100-watt soldering iron with a clean, chisel-shaped tip will supply the right amount of heat when used correctly. Notice how the iron is held in the picture. Heat the iron for 10 minutes before you start soldering. Keep the tip brightly coated with solder. When necessary, wipe the hot tip clean with a cloth. (If you use a soldering gun, be sure the tip reaches full heat before you solder.)

USE ONLY ROSIN CORE SOLDER

We supply the right kind of solder (*rosin core solder*). Do not use any other kind of solder! USE OF ACID CORE SOLDER, PASTE, OR IRONS CLEANED ON A SAL AMMONIAC BLOCK WILL RUIN ANY ELECTRONIC UNIT AND WILL VOID THE GUARANTEE.



1. Join bare metal to bare metal



2. Press FLAT side of a HOT iron

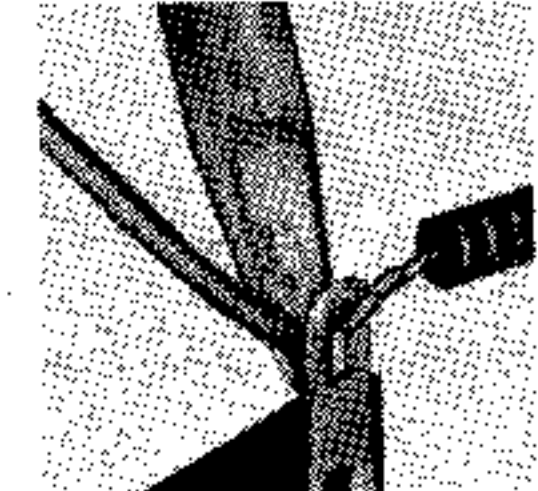

3. Apply solder BETWEEN iron and connection

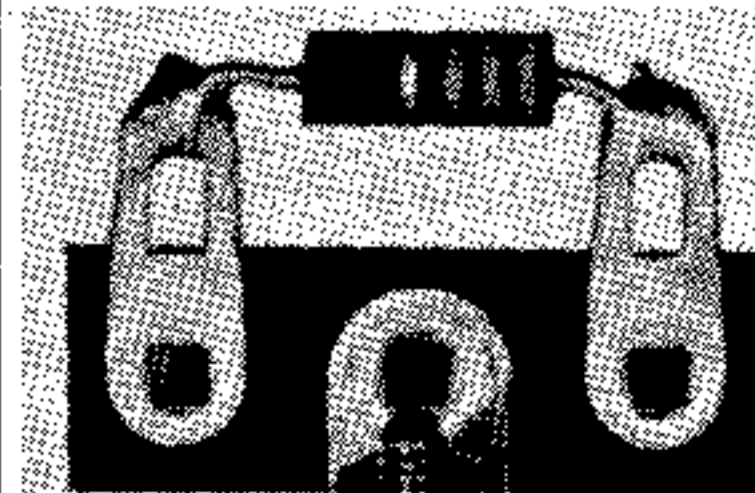

Compare your soldering with these pictures.

THE ONE-TWO-THREE OF GOOD SOLDERING.

PARTS MOUNTING ON THE IF PRINTED CIRCUIT BOARD

SEE FIGURE 1.

From the top of the IF printed circuit board (the side with the parts identified), mount the parts listed in the following 33 steps. These steps give the symbol numbers and values of all the resistors to be mounted on the IF printed circuit board. Insert the wire leads through the holes indicated, and bend the wires on the foil side of the board to hold the parts in place. The colors given in parenthesis are those of the stripes on the respective resistors. The following resistors are all $\frac{1}{2}$ watt unless specified otherwise.

- R-23, 2.7 meg Ω (red, violet, green)
- R-21, 5600 Ω (green, blue, red)
- R-16, 220K Ω (red, red, yellow)
- R-17, 2.7 meg Ω (red, violet, green)
- R-18, 1500 Ω (brown, green, red)
- R-20, 100K Ω (brown, black, yellow)
- R-19, 2700 Ω (red, violet, red)
- R-27, 2700 Ω (red, violet, red)
- R-49, 220K Ω (red, red, yellow)
- R-3, 100K Ω (brown, black, yellow) 1 watt
- R-22, 330 Ω (orange, orange, brown)
- R-26, 47K Ω (yellow, violet, orange)
- R-30, 680 Ω (blue, gray, brown). Omit if you have S-Meter Kit.
- R-28, 100K Ω (brown, black, yellow)
- R-45, 2700 Ω (red, violet, red)
- R-31, 47K Ω (yellow, violet, orange)
- R-33, 2700 Ω (red, violet, red)
- R-35, 1 meg Ω (brown, black, green)
- R-34, 1 meg Ω (brown, black, green)
- R-41, 220K Ω (red, red, yellow)
- R-40, 220K Ω (red, red, yellow)
- R-50, 3.3 Ω (orange, orange, gold)
- R-43, 1 meg Ω (brown, black, green)
- R-42, 1 meg Ω (brown, black, green)
- R-46, 470K Ω (yellow, violet, yellow)
- R-48, 100 Ω (brown, black, brown)
- R-47, 82 Ω (gray, red, black)
- R-54, 100K Ω (brown, black, yellow)
- R-29, 27K Ω (red, violet, orange)
- R-39, 100K Ω (brown, black, yellow)
- R-38, 39K Ω (orange, white, orange)
- R-37, 220K Ω (red, red, yellow)
- R-36, 47K Ω (yellow, violet, orange)

There are a number of disc capacitors, as well as other types, to be mounted on the IF printed circuit board. Several have the same value. Sort the disc capacitors into the following groups: .01 μ fd (may be marked 10,000 or 10K)—seven of this value; .0015 μ fd (1500 or 1.5K)—four; 470 μ fd—three; .0047 μ fd (4700 or 4.7K)—two; and two 330 μ fd disc capacitors. This grouping makes it easier to find the required capacitors as needed. Mount the capacitors in the following order:

- | | |
|--|--|
| <input checked="" type="checkbox"/> C-27, 470 μ fd | <input checked="" type="checkbox"/> C-48, 330 μ fd |
| <input checked="" type="checkbox"/> C-17, .0047 μ fd | <input checked="" type="checkbox"/> C-43, .02 μ fd |
| <input checked="" type="checkbox"/> C-23, .0015 μ fd | <input checked="" type="checkbox"/> C-60, 25 μ fd |
| <input checked="" type="checkbox"/> C-25, .01 μ fd | <input checked="" type="checkbox"/> C-50, 330 μ fd |
| <input checked="" type="checkbox"/> C-24, .01 μ fd | <input checked="" type="checkbox"/> C-46, .0015 μ fd |
| <input checked="" type="checkbox"/> C-30, .0015 μ fd | <input checked="" type="checkbox"/> C-51, .0047 μ fd |
| <input checked="" type="checkbox"/> C-32, .01 μ fd | <input checked="" type="checkbox"/> C-52, 470 μ fd |
| <input checked="" type="checkbox"/> C-33, .01 μ fd | <input checked="" type="checkbox"/> C-42, .01 μ fd |
| <input checked="" type="checkbox"/> C-35, .002 μ fd | <input checked="" type="checkbox"/> C-41, .0015 μ fd |
| <input checked="" type="checkbox"/> C-37, .01 μ fd | <input checked="" type="checkbox"/> C-45, .01 μ fd |
| <input checked="" type="checkbox"/> C-44, 470 μ fd | |

CAUTION: Bend L-13 leads carefully to prevent breaking the thin wires.

- Mount L-13, the 5 mh RF choke.
- Solder all of the leads and terminals of the parts just mounted to the metal foil right at the holes in the printed circuit board. Be sure to get the point to be soldered HOT enough. Refer to page 5 again. After soldering, cut off all the leads close to the board.
- Notice that the three IF transformers are in stand-up cans and each has four terminals. These three transformers are all the same, so it makes no difference which you use as Z-1, Z-2, or Z-3. The IF transformers must be installed in the correct locations as shown on the circuit board. There is a color dot on the terminal-end of each transformer that must be in the position shown in Figure 1. The transformers will "snap" in place with moderate pressure from the top.
- Mount the IF transformers, Z-1, Z-2, and Z-3.
- Use a tube carton to lean the board on edge. This prevents the solder from running down the terminal inside the transformer and shorting out the transformer. This would happen if the board were turned completely over to solder the IF transformer terminals.
- Solder each terminal of the three IF transformers to the foil on the printed circuit board. Solder the clips which hold the transformers in place.
- Install L-15, the BFO coil (in a two-terminal can). This coil can be installed in only one way. Solder the two terminals of L-15 and the two clips which hold the can to the board.

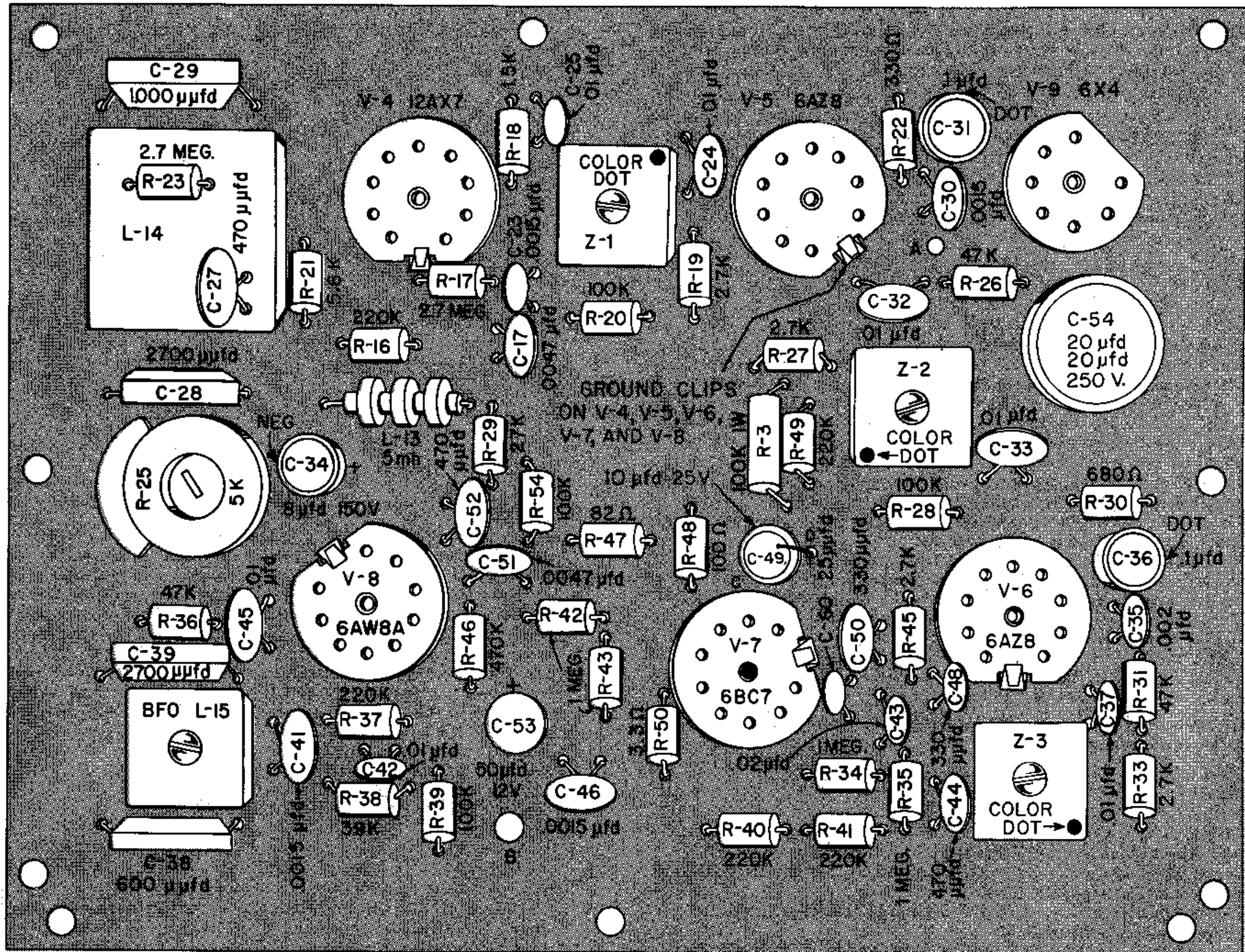

FIGURE 1. PARTS MOUNTING ON THE IF PRINTED CIRCUIT BOARD

NOTE: There are nine different types of screws supplied. The following table lists all of them according to thickness and length, starting with the thinnest and going to the thicker sizes.

SCREWS

THICKNESS	THREADS PER INCH AND LENGTH IN INCHES	QUANTITY
No. 3	48 x 1/4	6
No. 4	36 x 3/8	23✓
No. 6	32 x 1/4	5
No. 6 flathead	32 x 5/16	2✓
No. 6	32 x 5/16	64✓
No. 6	32 x 7/16	2✓
No. 8	32 x 1/4	3✓
No. 6 (setscrews)	32 x 1/4	2
No. 8 (setscrews)	32 x 1/4	4

✓ Group the screws according to the table above.

Before mounting L-14, the QX coil, in its can, two wires must be connected to it. L-14 has two terminals and an adjusting screw. See Figure 2.

✓ Cut 4½" of stranded red wire. Remove ¼" of the insulation at both ends. Twist the bare stranded wires tightly, and coat with solder. Solder one end of this wire to either terminal of L-14.

✓ From both ends of another 4½" stranded red wire, remove ¼" of the insulation. Twist the bare stranded wires tightly; coat with solder, and solder one end of this wire to the other terminal of L-14.

✓ Use two 6-32 x ¼" screws, two lockwashers, and two nuts to mount two spade lugs at the bottom of the QX can.

✓ Install L-14 into its can by pushing the mounting clip of L-14 through the large hole on top of the QX can so the locating pin comes into place and the mounting springs "snap" through the large hole. See Figure 2.

✓ Push the two red stranded wires from the QX coil through the large hole on the IF printed circuit board.

✓ Install the QX can on top of the board so that the spade lugs fit in the proper holes. Turn the board over and fasten the QX can using two #6 lockwashers and nuts over the spade lugs.

NOTE: Mica capacitors may be shaped slightly different, but the electrical value does not change.

✓ Mount C-38, a 600 µfd mica capacitor.

✓ Mount C-39, a 2700 µfd mica capacitor.

✓ Mount C-28, a 2700 µfd mica capacitor.

✓ Mount C-29, a 1000 µfd mica capacitor.

✓ Solder and clip each lead of the four capacitors just mounted.

✓ Solder either red wire from the QX coil to hole B-1 on the foil side of the board. See Figure 6.

✓ Solder the other red wire from the QX coil to hole 24-A on the foil side of the board. See Figure 6.

✓ Mount R-25, 5KΩ QX NULL control, from the top of the board. Solder the three terminals and flat mounting clip surrounded by foil to the metal foil.

From the top of the IF printed circuit mount the following tube sockets. The tube sockets "snap" through the holes to the proper position.

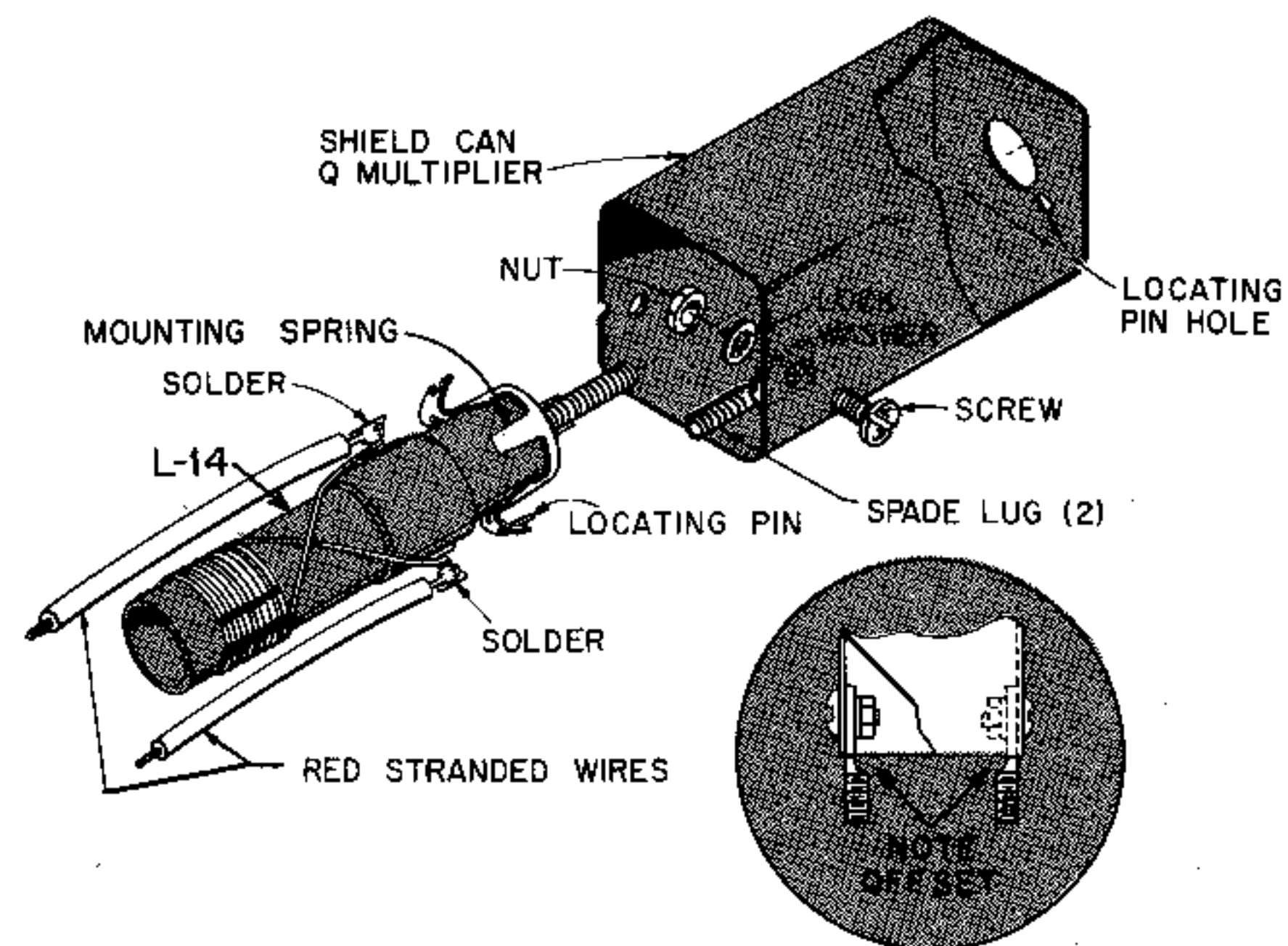

FIGURE 2. MOUNTING THE QX COIL

✓ Mount the five 9-pin tube sockets (with a ground clip) for V-4, V-5, V-6, V-7, and V-8.

✓ Mount the 7-pin tube socket (without a ground clip) for V-9.

CAUTION: When soldering the pins of the tube sockets to the foil, **DO NOT** use so much solder that it runs down the pins and comes out the holes in the top of the socket. If this should occur, your receiver will be shorted and will not operate when the tube shields are put over the tubes.

✓ Solder all of the tube socket pins to the metal foil. Be sure to solder the large center pins too.

NOTE: The stand-up type capacitors **MUST** be positioned as shown to maintain proper polarity of the circuit. They may be marked with a color dot, a bulge in the side of the case, stamped NEG, POS or ++++. Be sure the marking is as shown in the illustration.

✓ Mount C-31, a .1 µfd stand-up molded tubular capacitor.

✓ Mount C-36, a .1 µfd stand-up molded tubular capacitor.

✓ Mount C-53, a 50 µfd 12 v electrolytic capacitor.

✓ Mount C-34, an 8 µfd 150 v electrolytic capacitor.

✓ Solder and clip each lead of the capacitors just mounted.

✓ Mount C-54, a 20-20 µfd 250 v electrolytic stand-up capacitor. It will mount only one way. Solder the two terminals and the three mounting tabs of C-54 to the foil of the board.

✓ Prepare C-49, a 10 µfd 25 v electrolytic capacitor, for mounting by bending the lead from the +++ end along the body of the capacitor. Both leads will point down. Insert the +++ lead in hole D, the other lead in hole C.

✓ Solder both leads of C-49 to the foil. **DO NOT CUT THE LONGER LEAD.** Cut only the shorter lead (from the +++ end). Put the IF printed circuit board aside for the time being.

FIRST PARTS MOUNTING ON THE CHASSIS

SEE FIGURE 3 ON A LARGE SEPARATE SHEET.

CAUTION: You are now ready to install the parts on the chassis. Some parts, especially the rotary wafer switches, are quite fragile. When you handle them, connect, or solder wires to them, DO NOT put undue pressure on the wafer—it may break easily.

Position the chassis as shown.

- ✓ From inside the chassis, mount J-1, the coaxial ANTENNA jack, with four 4-36 x 3/8" screws and matching lockwashers and nuts.
- ✓ From outside the chassis, mount TS-1, a two-screw terminal strip. Use two 6-32 x 5/16" screws, one lockwasher, one solder lug, and two nuts. Position the solder lug as shown.
- ✓ From outside the chassis, mount TS-2, a two-screw terminal strip. Use two 6-32 x 5/16" screws. Mount TS-3; a four-terminal strip with the right-hand screw of TS-2 and position as shown. Fasten with two matching lockwashers and nuts.
- ✓ From outside the chassis, mount the F-1 fuse holder with the hardware supplied. Place the rubber washer under the head of the fuse holder. Position the terminals exactly as shown. Bend terminal 1 away from the holder.

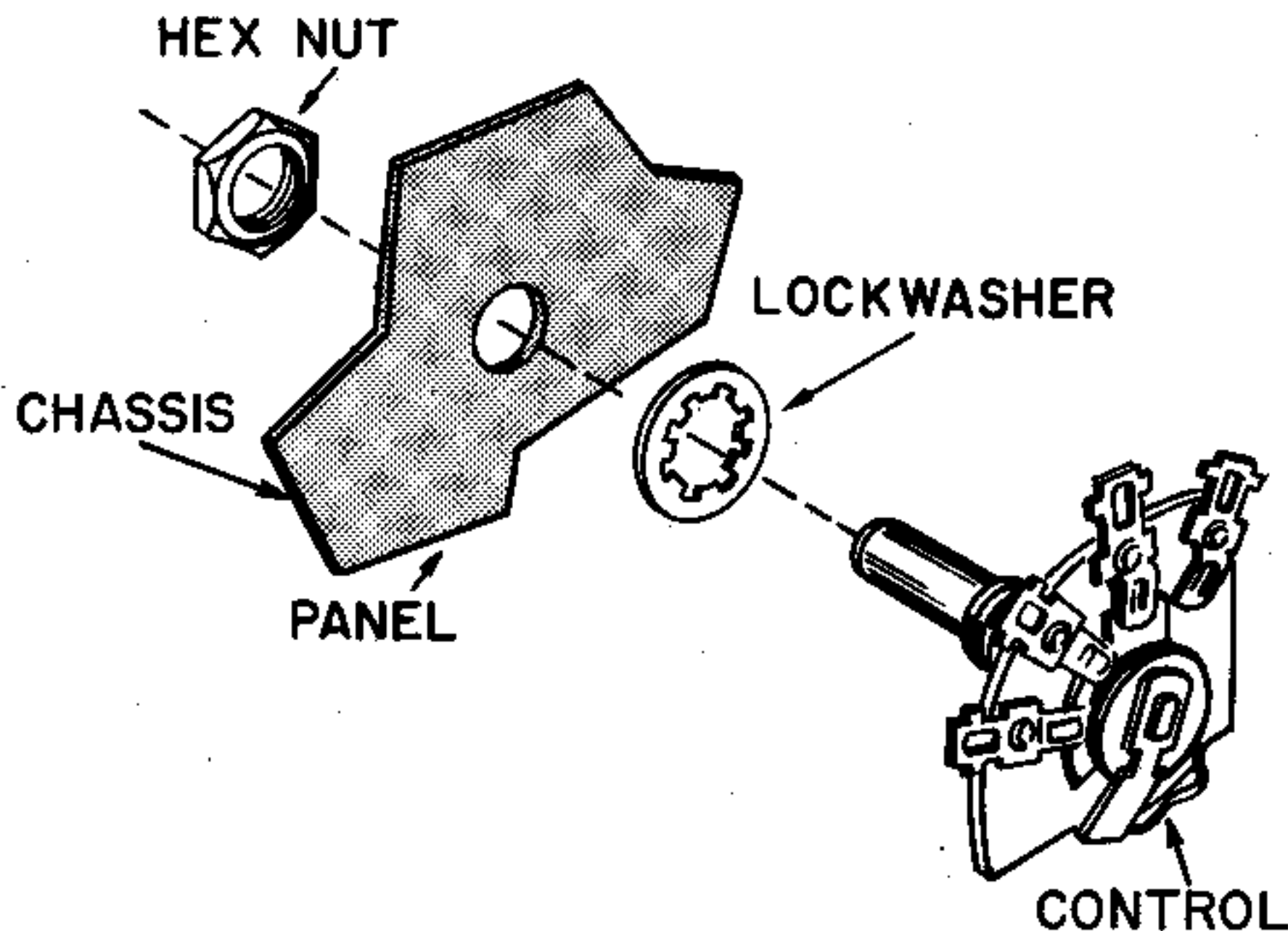

FIGURE 4. HOW TO MOUNT A CONTROL

- ✓ Press the large rubber grommet into the hole as shown.
- ✓ From outside the chassis, mount TS-4, a two-screw terminal strip. Use two 6-32 x 5/16" screws. Mount TS-5, the three-terminal strip with the screw of TS-4 closest to the rubber grommet. Position as shown. Fasten with two matching lockwashers and nuts.
- ✓ From inside the chassis, mount S-3, the BFO-MVC-AVC-ANL switch on the front. Use one 3/8" lockwasher and one nut. See Figure 4. Position the terminals as shown in Figure 3.
- ✓ In a like manner, mount R-44, the 1 megohm AF GAIN control. Use one 3/8" lockwasher and one nut. Position the terminals as shown in Figure 3.
- ✓ In a like manner, mount S-2, the PEAK-OFF-NULL switch. Use one 3/8" lockwasher and one nut. Position the terminals as shown in Figure 3.
- ✓ Before mounting C-26, solder one end of a yellow wire to terminal 1. The other end of this wire will be connected later. Also, clip off terminal as shown. From inside the chassis, mount C-26 with three 6-32 x 1/4" screws.
- ✓ From inside the chassis, mount R-24, the 10KΩ QX SELECTIVITY control, with one 3/8" ground lug, lockwasher and nut as shown in Figure 5. Position the terminals as shown in Figure 3.

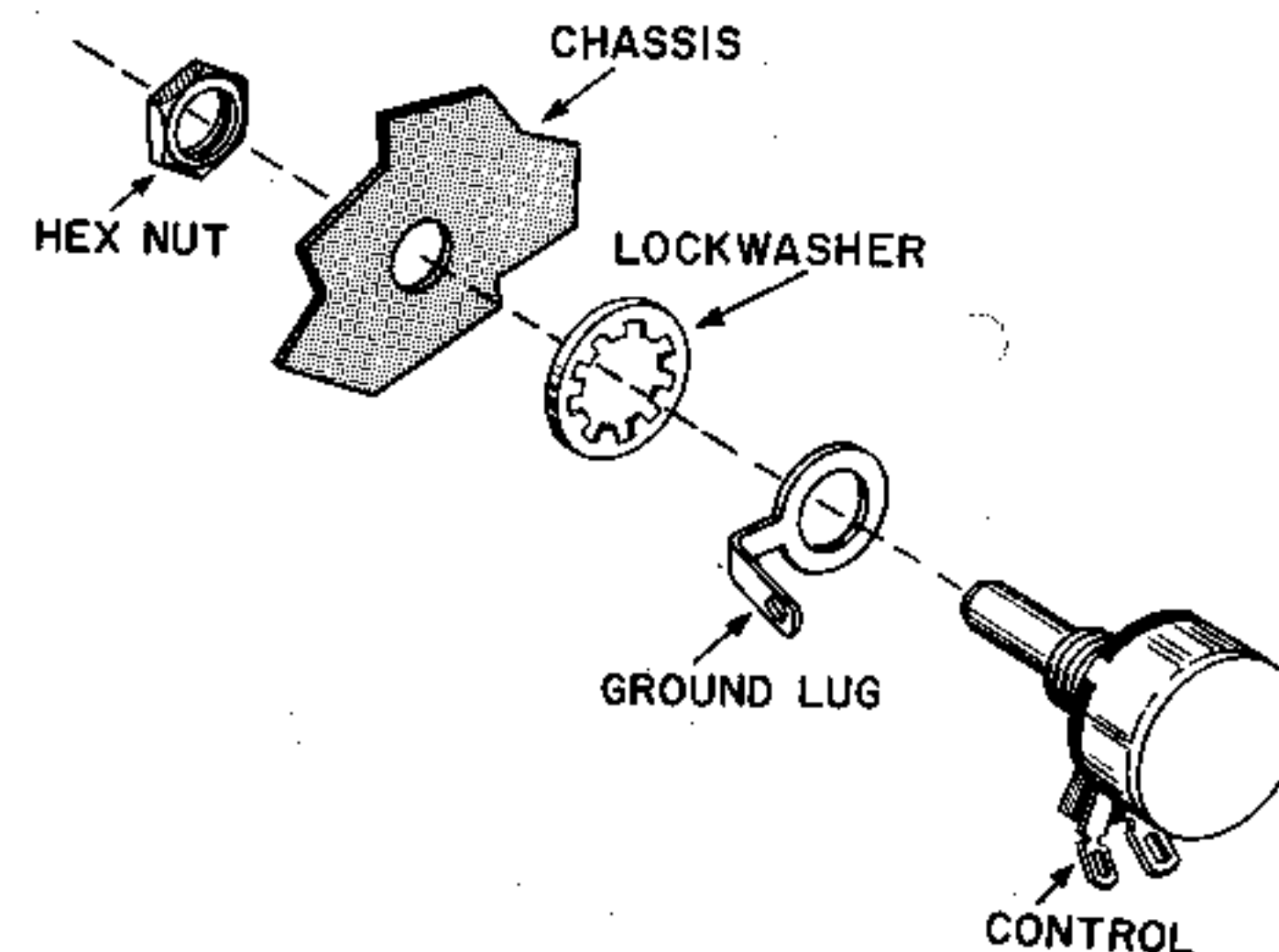

FIGURE 5. HOW TO MOUNT A CONTROL USING A GROUND LUG

The power transformer, T-2, mounts from the top of the chassis.

- ✓ Push the seven T-2 leads through the large hole as shown.
- ✓ Fasten T-2 to the chassis with four 6-32 x 5/16" screws, lockwashers, and nuts.

NOTE: Prop the chassis on a box to protect the QX coil.

- ✓ From the top of the chassis, mount the IF printed circuit board, foil side down against the chassis. Use ten 4-36 x 3/8" screws, nine lockwashers, one solder lug, and ten nuts as shown.

L-16 is a 5.5 henry filter choke. This choke has two black leads.

- ✓ Cut both leads of L-16 to 2 1/2". Remove 1/4" insulation from each. Twist the bare wire strands of each lead tightly together, and coat with solder.
- ✓ From inside the chassis, mount L-16 with two 6-32 x 5/16" screws, lockwashers, and nuts.

FIRST PARTS WIRING ON THE CHASSIS

SEE FIGURE 6 on a large separate sheet.

Stand the chassis on edge with the large square opening to your left.

- ✓ Solder terminal 2 on TS-1 to the solder lug mounted with TS-1.
- ✓ Connect, but do not solder one lead of R-1, a 68Ω resistor (blue, gray, black), to terminal 1 of TS-2. Connect, but do not solder, the other lead to terminal 4 of TS-3.

See detail wiring of TS-2 and TS-3 on Figure 6.

- ✓ Connect, but do not solder, one lead of C-55, a .0047 μfd (4700 or 4.7K), disc capacitor, to terminal 3 of TS-3. Pass the other lead through terminal 2 of TS-3, looping it once. Then solder the lead to terminal 2 of TS-2.
- ✓ Connect, but do not solder, the shortest T-2 black lead to terminal 3 of TS-3. Connect, but do not solder, the other T-2 black lead to terminal 2 of F-1.

- ✓ Connect, but do not solder, either of the T-2 green leads to the solder lug mounted with the IF printed circuit board, as shown. Solder the other T-2 green lead to hole 4 on the IF printed circuit board.
- ✓ Solder the T-2 red-yellow lead to hole 3.
- ✓ Solder either of the T-2 red leads to hole 2.
- ✓ Solder the other T-2 red lead to hole 1.
- ✓ Solder one end of a 1 1/2" bare wire to terminal 1 of TS-4. Solder the other end to terminal 2 of TS-5.
- ✓ Solder one of the L-16 leads to hole 9 on the IF printed circuit board. Solder the other L-16 lead to hole 18.
- ✓ Solder one end of a green wire to terminal 3 of S-3. Solder the other end to hole 27 on the IF printed circuit board.
- ✓ Solder one end of a blue wire to terminal 4 of S-3. Solder the other end to hole 29 on the IF printed circuit board.
- ✓ Cut an 8 1/4", an 8", and an 11 1/2" length of **uninsulated shielded** wire. Prepare as shown in Figure 7.

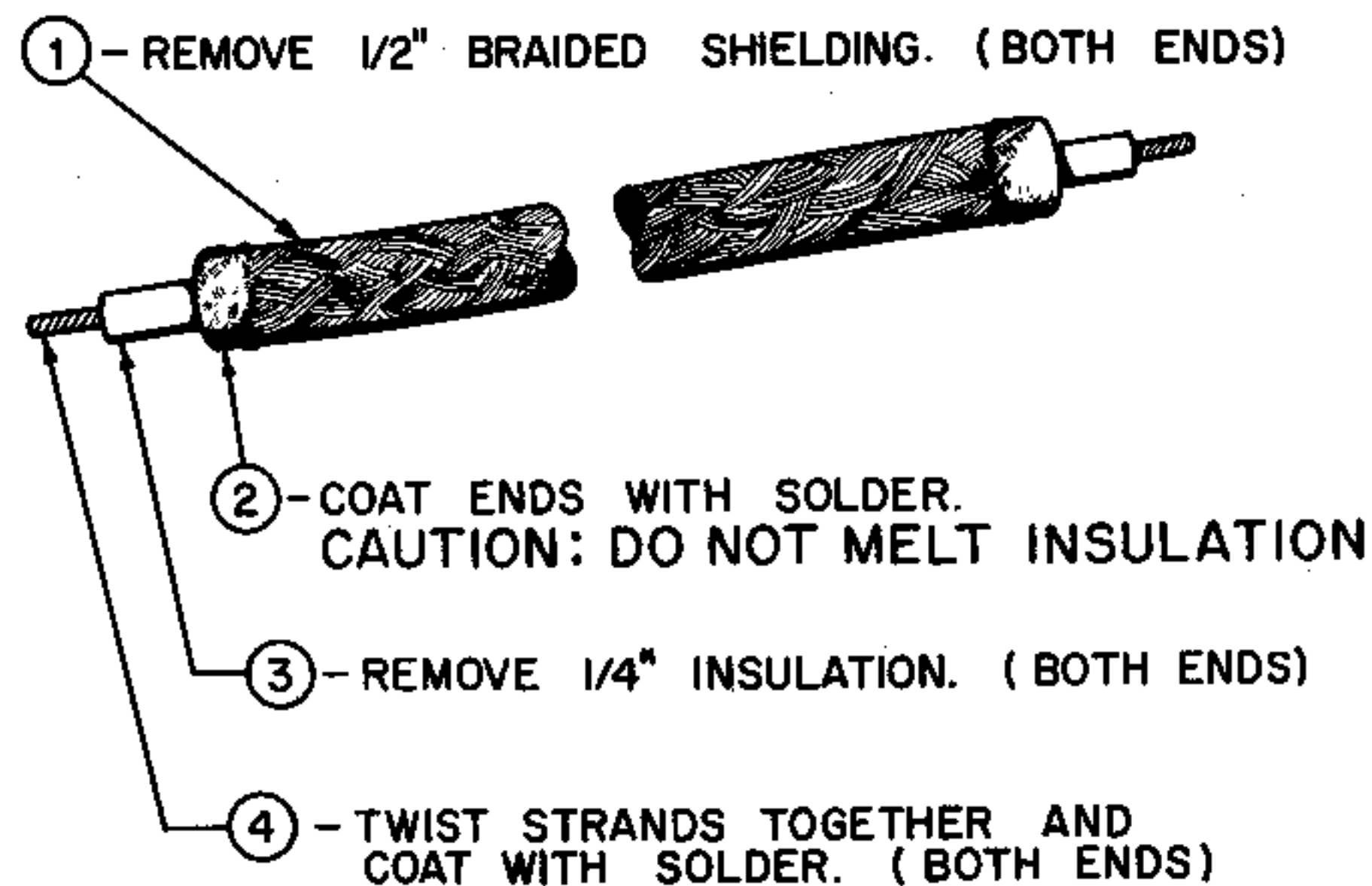

FIGURE 7. PREPARING UNINSULATED SHIELDED WIRES

- ✓ Solder the inner conductor of the 8" shielded wire to terminal 2 of S-3. Solder the other end of the inner conductor to hole 31 on the IF printed circuit board.
- ✓ Connect, but do not solder, the inner conductor of one end of the 8¼" shielded wire to terminal 1 of S-3. Solder the other end of the inner conductor to hole 30 on the IF printed circuit board.
- ✓ Solder one end of a 3" bare wire to terminal 5 of S-3. Pass the other end of this wire through terminal 1 of R-44. DO NOT cut this wire. The free end will be connected later.
- ✓ Solder one end of the inner conductor of the 11½" shielded wire to terminal 2 of R-44. Being careful NOT to melt the inner insulation, solder the braided shield of the same end to terminal 1 of R-44. Solder the inner conductor of the other end to hole 23 on the IF printed circuit board. To this end of the braided shield solder the long lead from C-49, left from an earlier step.
- ✓ Put a 1½" piece of spaghetti on each lead of C-47, a .0047 µfd (4700 or 4.7K) disc capacitor. Solder one lead to terminal 3 of R-44. Solder the other lead to terminal 1 of S-3.
- ✓ As shown in Figure 8, wrap 3½" of the bare wire around the three shielded wires. Solder them together at this point. Push these wires neatly down against the chassis.
- ✓ Solder the ground lug mounted with R-24 to terminal 1 of R-24.
- ✓ Solder one end of a yellow wire to terminal 1 of S-2. Solder the other end to terminal 2 of R-24.

STEP 1

WRAP 3-1/2" BARE WIRE AROUND SHIELDED WIRES.



STEP 2

SOLDER (DO NOT OVERHEAT)



FIGURE 8. GROUNDING SHIELDED WIRES

- ✓ Solder one end of a yellow wire to terminal 2 of S-2. Solder the other end to hole 17 on the IF printed circuit board.
- ✓ Solder one end of an orange wire to terminal 3 of S-2. Solder the other end to hole 22.
- ✓ Solder one end of a yellow wire to terminal 4 of S-2. Solder the other end to hole 16.
- ✓ Solder one end of an orange wire to terminal 5 of S-2. Solder the other end to hole 24B.
- ✓ Solder the free end of the yellow wire previously soldered to terminal 1 of C-26 to hole B-2.
- ✓ Cut a 4" piece of insulated shielded wire. Prepare this wire as shown in Figure 9A.
- ✓ Solder the inner conductor at the end with clipped shielding to terminal 7 of S-2.
- ✓ Solder the other end of the inner conductor of the 4" insulated shielded wire to hole 14. Solder the braided shielding to the center pin of V-4 as shown in Figure 6.
- ✓ Cut a 4½" piece of insulated shielded wire. Prepare this wire as shown in Figure 9B.
- ✓ Solder the inner conductor at the end with the 3" bare wire to hole 15. The other end of the 3" bare wire will be connected later.
- ✓ Solder the inner conductor at the other end of this 4½" insulated shielded wire to terminal 6 of S-2.

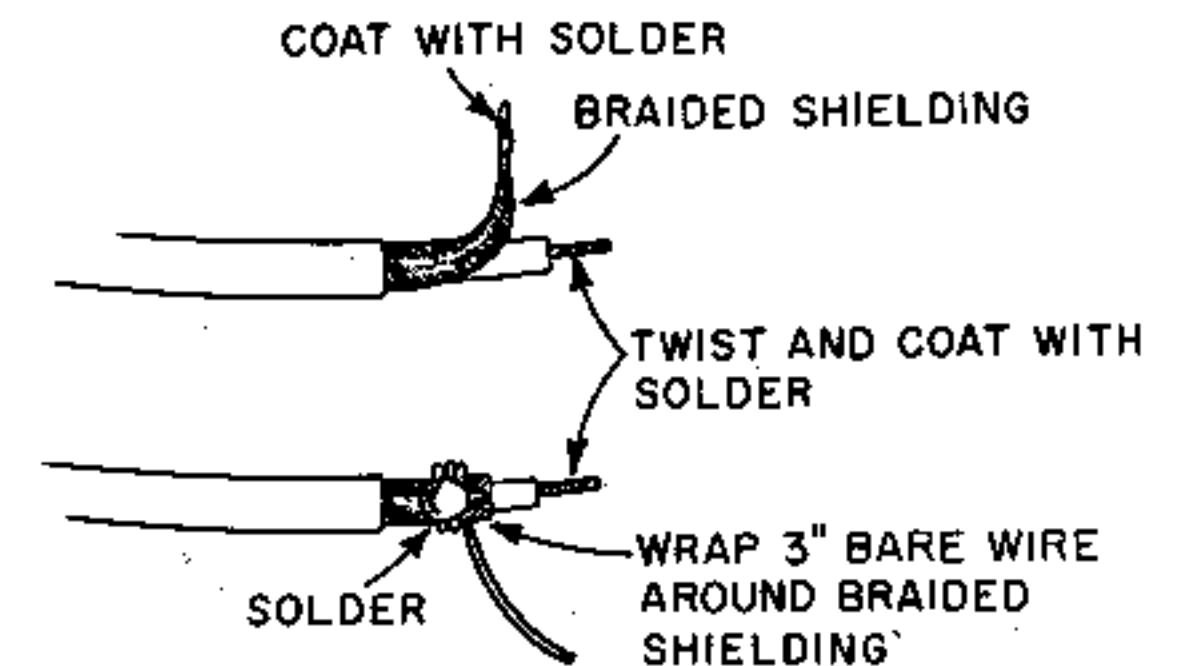
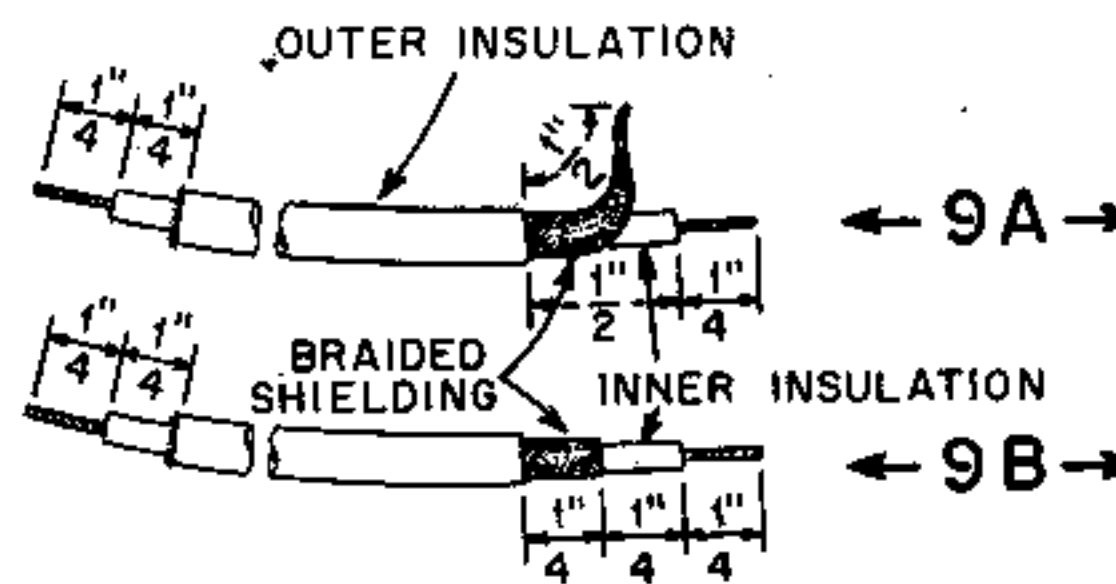

FIGURE 9. PREPARING INSULATED SHIELDED WIRES

PREPARING AND INSTALLING THE 9-CONDUCTOR CABLE

SEE FIGURE 10A.

- Trim the 9-conductor cable to 28".
- Strip 7½" outer covering from one end of the cable. Strip 4½" outer covering from the other end. Be careful not to damage the insulation of the 9 individual wires.
- Shorten the wires at each end of the cable to the lengths given in Figure 10A. The lengths are measured from the end of the outer covering.
- Remove ¼" insulation from all wires at both ends of the cable. Twist the bare ends of each wire and coat each lightly with solder.

It is easier to connect the cable to S-4 and R-2 before they are permanently mounted inside the chassis. A convenient, temporary mounting place is the outside of the chassis, at the 2 unused mounting holes near the corner of the chassis.

- Temporarily mount S-4 (OFF-STBY-RCV-CAL switch) and R-2 (5KΩ RF GAIN control) on the outside of the chassis. Position the terminals as shown in Figure 10B.
- See Figure 10B. Place the end of the cable, from which 4" outer covering was stripped, in position for wiring to S-4 and R-2.

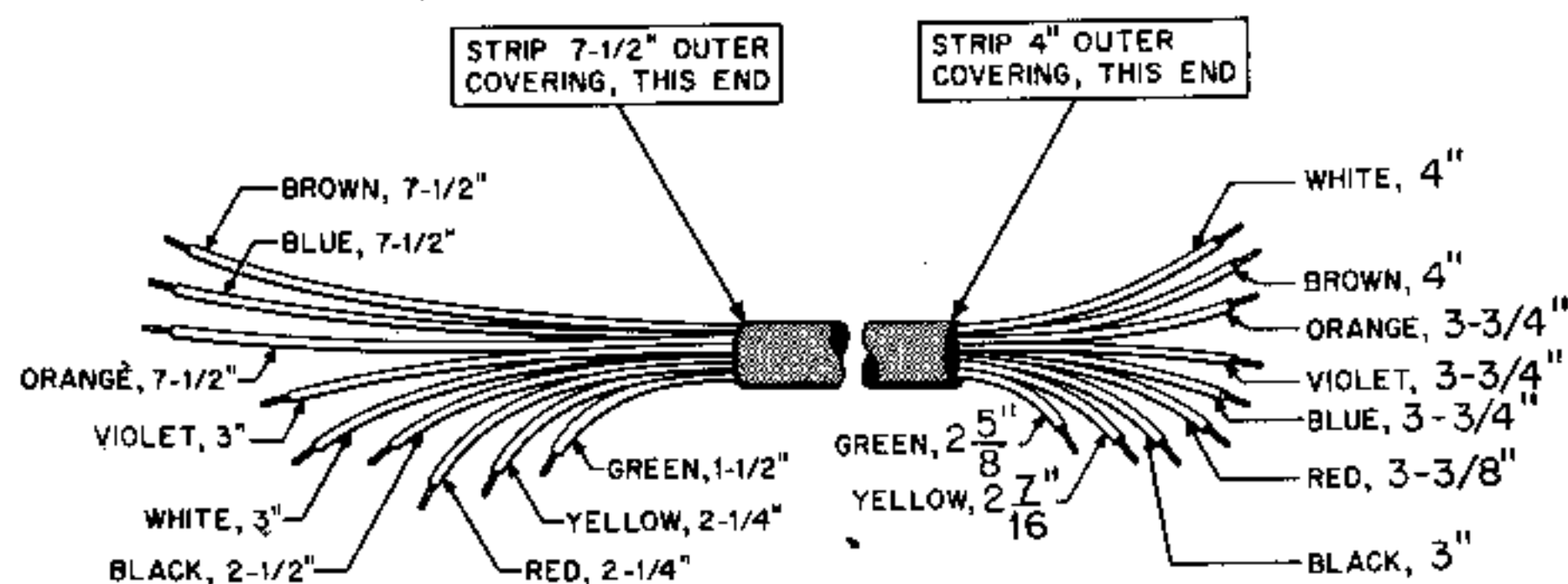

REMOVE ¼" INSULATION FROM ALL WIRES AT BOTH ENDS OF THE CABLE. TWIST ENDS AND COAT WITH SOLDER.

FIGURE 10A. PREPARING THE 9-CONDUCTOR CABLE

SEE FIGURE 10B.

- Solder the brown wire to terminal 1 of R-2.
- Solder the orange wire to terminal 2 of R-2.
- Solder the violet wire to terminal 3 of R-2.
- Solder the white wire to terminal 1 of S-4.
- Solder the blue wire to terminal 2 of S-4.
- Solder the red wire to terminal 3 of S-4.
- Solder the black wire to terminal 4 of S-4.
- Solder the green wire to terminal 5 of S-4.
- Solder the yellow wire to terminal 6 of S-4.

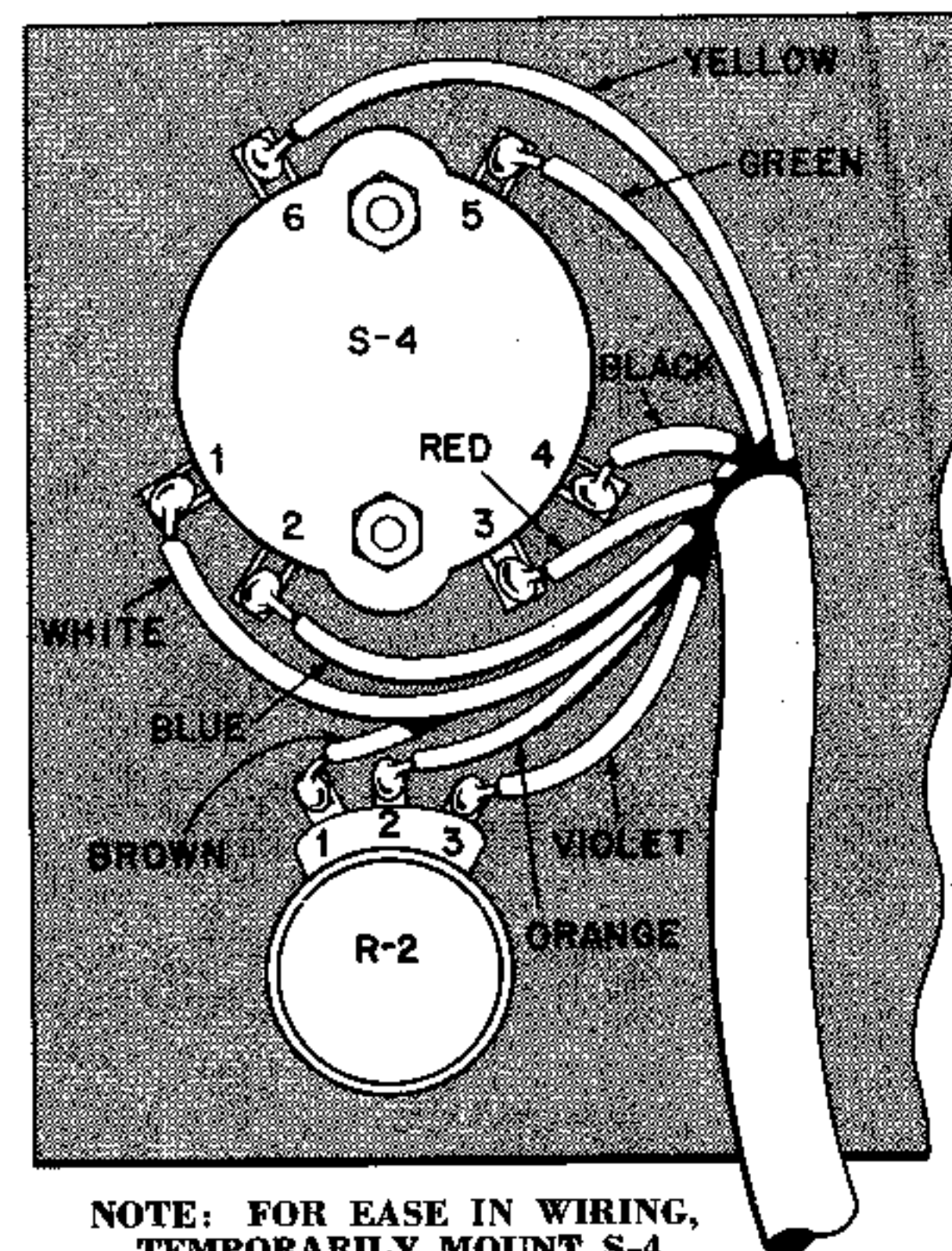

NOTE: FOR EASE IN WIRING, TEMPORARILY MOUNT S-4 AND R-2 ON THE OUTSIDE OF THE CHASSIS

FIGURE 10B. WIRING R-2 AND S-4

SECOND WIRING ON THE CHASSIS

SEE FIGURE 11 on a large separate sheet.

- Permanently mount R-2 and S-4 inside the chassis. Use hardware as shown in Figure 4. Carefully route the 9-conductor cable as shown in Figure 11. To protect S-4, do not allow the cable to pull on the switch.
- Prop the chassis up as shown.
Refer to the detail of TS-2 and TS-3 on Figure 11.
- Solder the yellow wire to terminal 1 of TS-2.
- Solder the violet wire to terminal 4 of TS-3.
- Solder the black wire to terminal 3 of TS-3.
- Connect, but do not solder, the green wire to terminal 2 of TS-3.
- Connect, but do not solder, the red wire to terminal 1 of TS-3.
- Solder the white wire to terminal 1 of TS-5.
- Solder the brown wire in hole 20 on the IF printed circuit board.
- Solder the blue wire in hole 12.
- Solder the orange wire in hole A-1.
- Solder one end of an orange wire to the center terminal of J-1. The other end of this wire will be connected later.
- Solder one lead of C-56, a .0047 μ fd (4700 or 4.7K) disc capacitor, to terminal 2 of F-1. Solder the other lead to terminal 2 of TS-3.
- From outside the chassis, push the bare end of the line cord through the grommet near F-1. Tie a knot in it 1½" from the bare end.
- Solder either of the line cord wires to terminal 1 of F-1. Solder the remaining wire to terminal 1 of TS-3.
- Mount J-2, the phone jack, with the hardware (flat washer outside of chassis) supplied. Position the terminals as shown.
- Connect, but do not solder, the free end of the bare wire previously soldered to terminal 1 of R-44 to terminal 1 of J-2.

- Solder one lead of R-51, a 33 Ω resistor (orange, orange, black), to terminal 1 of J-2. Connect, but do not solder, the other lead to terminal 3 of J-2.
- Solder one end of a white-blue wire to terminal 2 of J-2. Solder the other end to terminal 2 of TS-4.
- Close the plates of C-40, the 50 μ fd BFO capacitor, to protect them. C-40 is stamped 281011 and must not be confused with the 80 μ fd capacitor which has more plates.
- From inside the chassis, mount C-40 and the "L" shaped BFO shield plate. Insert the bushing through a lockwasher, the shield, the chassis, and a flat washer. Tighten the nut supplied over the bushing.
- Cut and prepare a 5" shielded wire as shown in Figure 7.
- Solder one end of a 1¼" bare wire to the braided shield at one end of the 5" shielded wire. Solder the inner conductor in hole 28 on the IF printed circuit board. Solder the other end of the 1¼" bare wire in hole 35.
- Solder the inner conductor at the other end of the 5" shielded wire to terminal 3 of C-40.
- Before mounting R-32, a 10 meg Ω resistor (brown, black, blue), clip both leads to ¼". Solder one lead of R-32, in hole 19 on the foil side of the IF printed circuit board. Solder the other lead to hole 36. Be sure the leads do not touch another part on the other side of the board.
- Prepare a 6" uninsulated shielded wire as shown in Figure 7.
- At one end of this shielded wire, wrap a 1" bare wire once around the shielding. Solder it.
- At the end with the bare wire, solder the inner conductor to terminal 2 of C-40. Solder the free end of the bare wire to terminal 1 of C-40. Solder the inner conductor at the other end to hole 32.

PARTS MOUNTING AND WIRING ON THE RF PRINTED CIRCUIT BOARD

SEE FIGURE 12.

As you did with the IF board, inspect this board carefully. Here, too, the two sides are different: A component side which has an outline of the parts printed on it, and a metal foil side with the wiring pattern etched on it. Hold the board so the component side is toward you. Mount parts from the component side in the following order. Check off each step as completed.

- Mount C-57, a 100 μmfd mica capacitor.
- Mount R-52, a 1 meg Ω resistor (brown, black, green).
- Mount C-59, a .01 μmfd (may be marked 10,000 or 10K) disc capacitor.
- Mount R-4, a 33 Ω resistor (orange, orange, black).
- Mount C-5, a .01 μmfd (10,000 or 10K) disc capacitor.
- Mount C-9, a .01 μmfd (10,000 or 10K) disc capacitor.
- Mount C-62, a .01 μmfd (10,000 or 10K) disc capacitor.
- Mount C-7, a .01 μmfd (10,000 or 10K) disc capacitor.
- Mount R-8, a 47K Ω resistor (yellow, violet, orange).
- Mount R-9, a 68 Ω resistor (blue, gray, black).
- Mount C-8, a .01 μmfd (10,000 or 10K) disc capacitor.
- Mount R-11, a 2200 Ω resistor (red, red, red).
- Mount R-10, a 6800 Ω resistor (blue, gray, red).
- Mount C-20, a 560 μmfd (.00056) disc capacitor.
- Mount R-53, a 10K Ω resistor (brown, black, orange).
- Mount R-15, an 820K Ω resistor (gray, red, yellow).
- Mount R-13, an 82K Ω resistor (gray, red, orange).
- Mount R-5, a 27K Ω resistor (red, violet, orange).
- Mount R-14, a 150 Ω resistor (brown, green, brown).
- Mount C-61, a .01 μmfd (10,000 or 10K) disc capacitor.
- Mount C-21, a .01 μmfd (10,000 or 10K) disc capacitor.
- Mount C-22, a .01 μmfd (10,000 or 10K) disc capacitor.
- Mount C-6, a 100 μmfd (.0001) mica capacitor.
- Mount C-58, the odd-shaped 100 μmfd mica capacitor with the glazed body and both leads coming from the same side.
- Mount R-7, a 10K Ω 1 Watt resistor (brown, black, orange).
- Mount C-11, a .01 μmfd (10,000 or 10K) disc capacitor.
- Mount R-6, a 4700 Ω 2 Watt resistor (yellow, violet, red)
- Mount C-14, a 2000 μmfd (.002 or 2K) mica capacitor.
- Mount C-13, a 680 μmfd (.00068) mica capacitor.
- Mount C-15, a 5000 μmfd (.005 or 5K) mica capacitor.
- Mount R-12, a 33 Ω resistor (orange, orange, black).
- Mount V-1, a 7-pin tube socket with a ground clip, as shown.
- Mount V-2, a 9-pin tube socket with a ground clip, as shown.
- Mount V-3, a 7-pin tube socket without a ground clip, as shown.

- Check your work thoroughly. When you are satisfied that all parts are mounted correctly, turn the board over and solder each lead to the foil at the point where the lead comes through the board. Be sure to use enough heat to get a good soldered connection. Cut off the excess leads close to the board. Refer to page 5. Carefully solder all the tube socket pins to the foil pattern. Be sure to solder the center pins.

As shown, insert the following wires from the component side, and solder them on the foil side.

- Solder one end of a yellow wire to hole X. The other end of the wire will be connected later.
- Solder one end of a green wire to hole Y. The other end of the wire will be connected later.
- Solder one end of a green wire to hole Z. The other end will be connected later.
- From the foil side of the board, mount S-1, the three-wafer printed circuit bandswitch. S-1 will fit only one way. Insert the terminals of S-1 firmly into the matching holes in the printed circuit board so the shoulders of the terminals seat against the board.

The switch must be firmly and evenly attached to the board *with no strain on either the switch or the board*. Turn the board over so the edge of each switch wafer is flat on your working surface. Gently press down on the board near the outer TWO terminals of the front wafer. Solder these TWO outer terminals (from the component side) as the board is pressed down.

NOTE: Hold the soldering iron tip against the switch terminal and let the solder flow down inside the metal hole to make a good electrical connection between the switch terminal and the foil conductor on the other side of the board.

Press down on the board, and solder the outer two terminals of the center wafer and the rear wafer. After each outer terminal of each wafer is well soldered, solder all the other terminals of each wafer. Be sure the solder flows down into the hole, *but do not let it flow onto an adjacent terminal or to nearby parts*.

- Mount C-4, a .1 μmfd stand-up tubular capacitor. Be sure the polarity marking is positioned as shown. Solder and clip both leads.

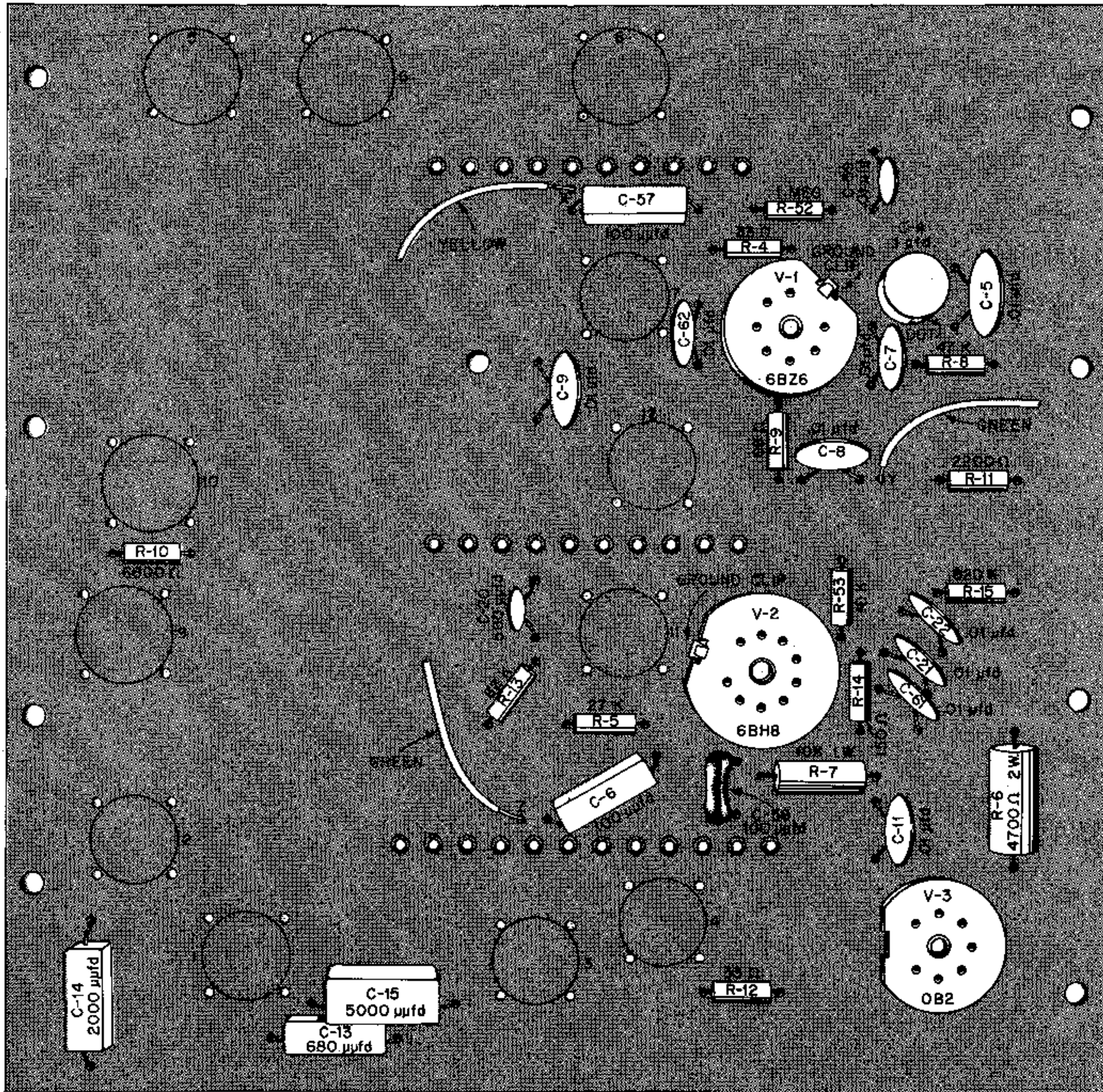

FIGURE 12. FIRST WIRING ON THE RF PRINTED CIRCUIT BOARD

MOUNTING THE COILS

Coils L-1 through L-12 MUST BE CORRECTLY POSITIONED AND MOUNTED or the receiver will not work. Carefully, but firmly, insert the coils from the component side of the board. BE SURE THE NUMBER ON THE SIDE OF THE COIL FACES THE SAME NUMBER PRINTED ON THE BOARD. For example, L-4 must be mounted so that the 4 on the coil faces the 4 on the board, as shown in the detail on Figure 13.

- Mount L-5.
- Mount L-6.
- Mount L-8, with C-64 attached.
- Mount L-7.
- Mount L-12.
- Mount L-11.
- Mount L-4.
- Mount L-3.
- Mount L-1.
- Mount L-2.
- Mount L-9.
- Mount L-10.

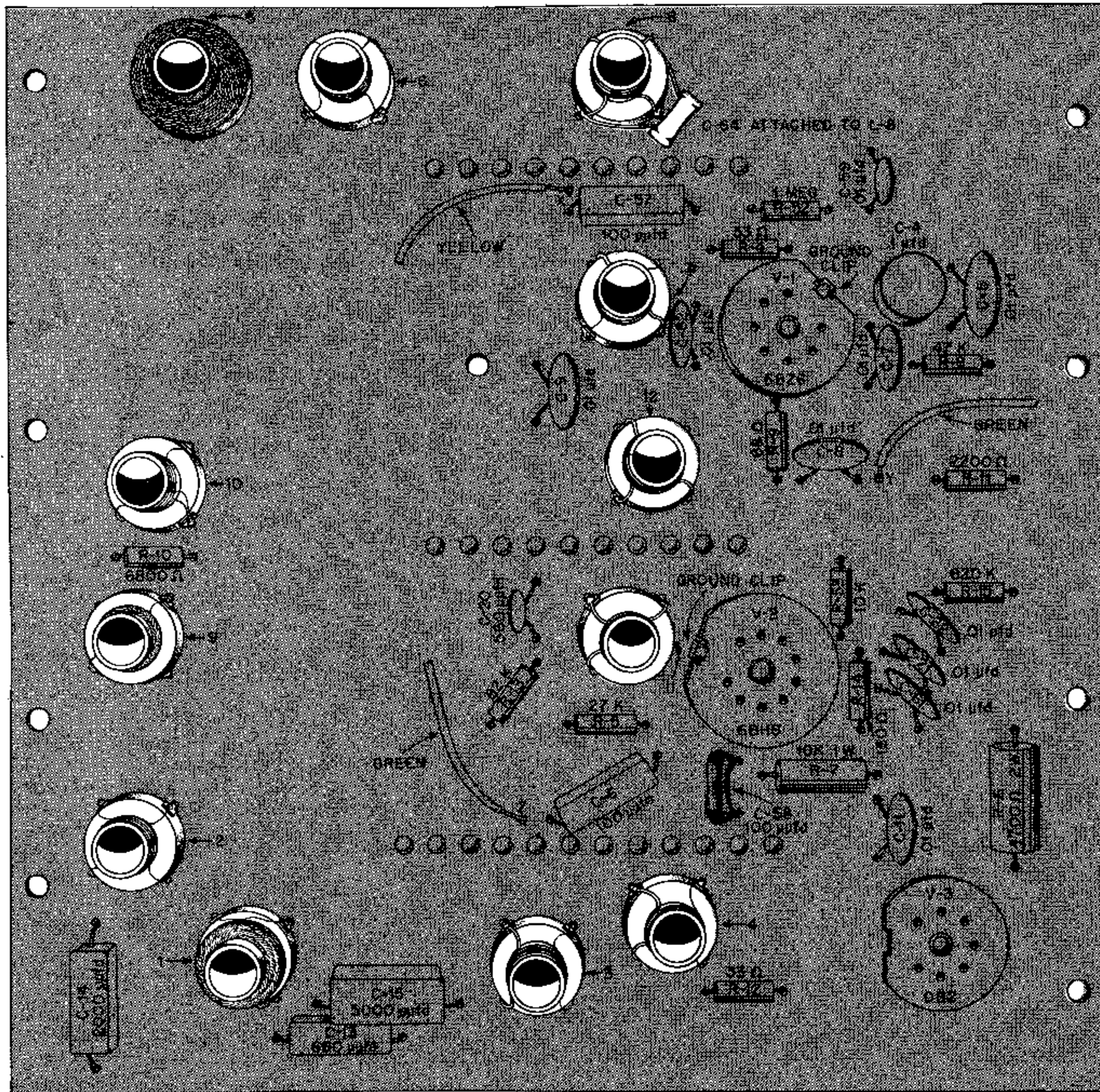
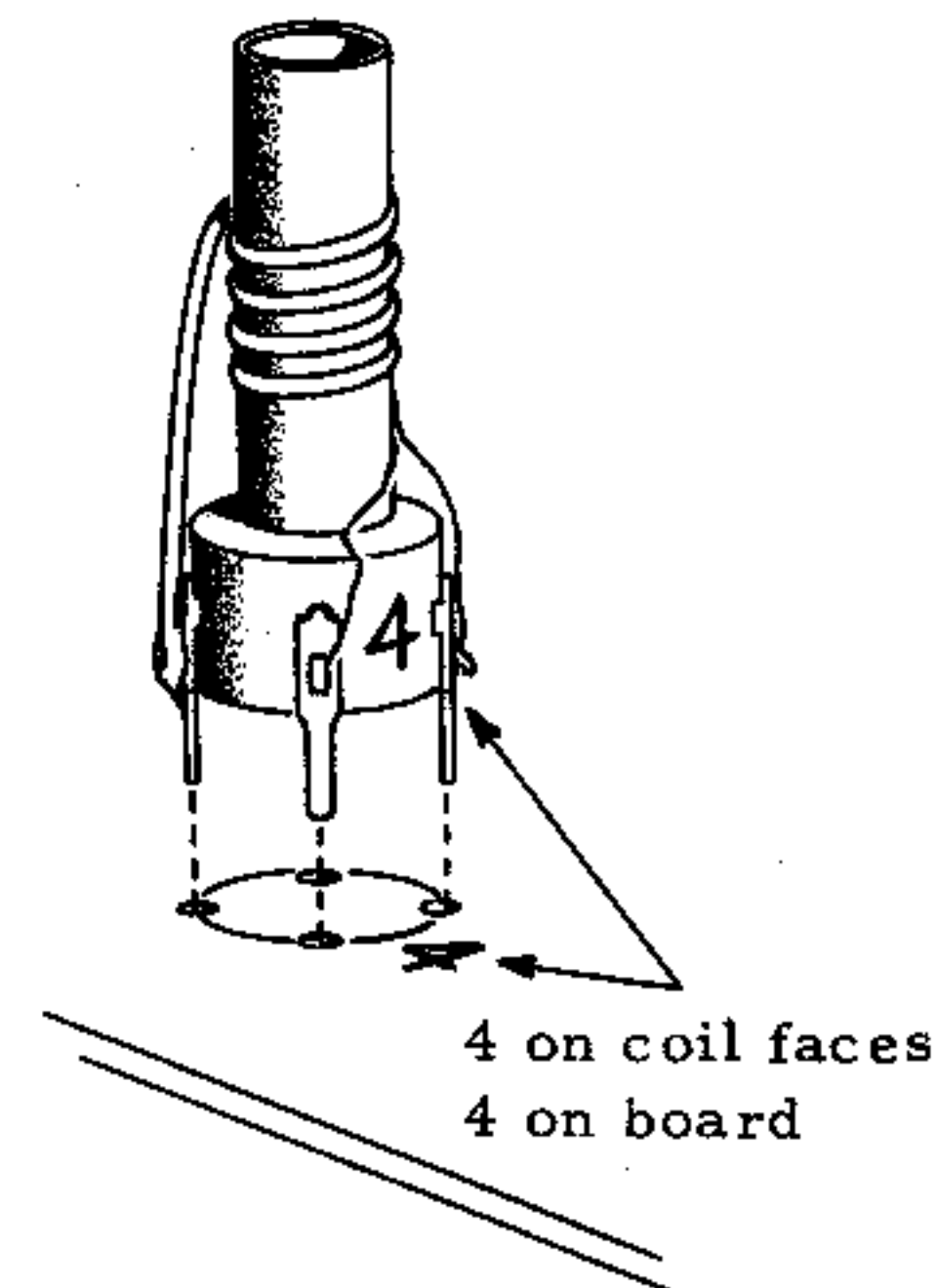

FIGURE 13. MOUNTING THE COILS

SOLDERING THE COILS

Before soldering the coil terminals, be sure each coil is firmly and flatly seated on the board. If these coils are not soldered in a perfectly vertical position, it may be difficult to adjust the slugs and align the receiver.

- Turn the board over. Do not bend the coil terminals. Solder all the coil terminals to the foil pattern. Handle the board carefully so that you do not damage any of the coils.

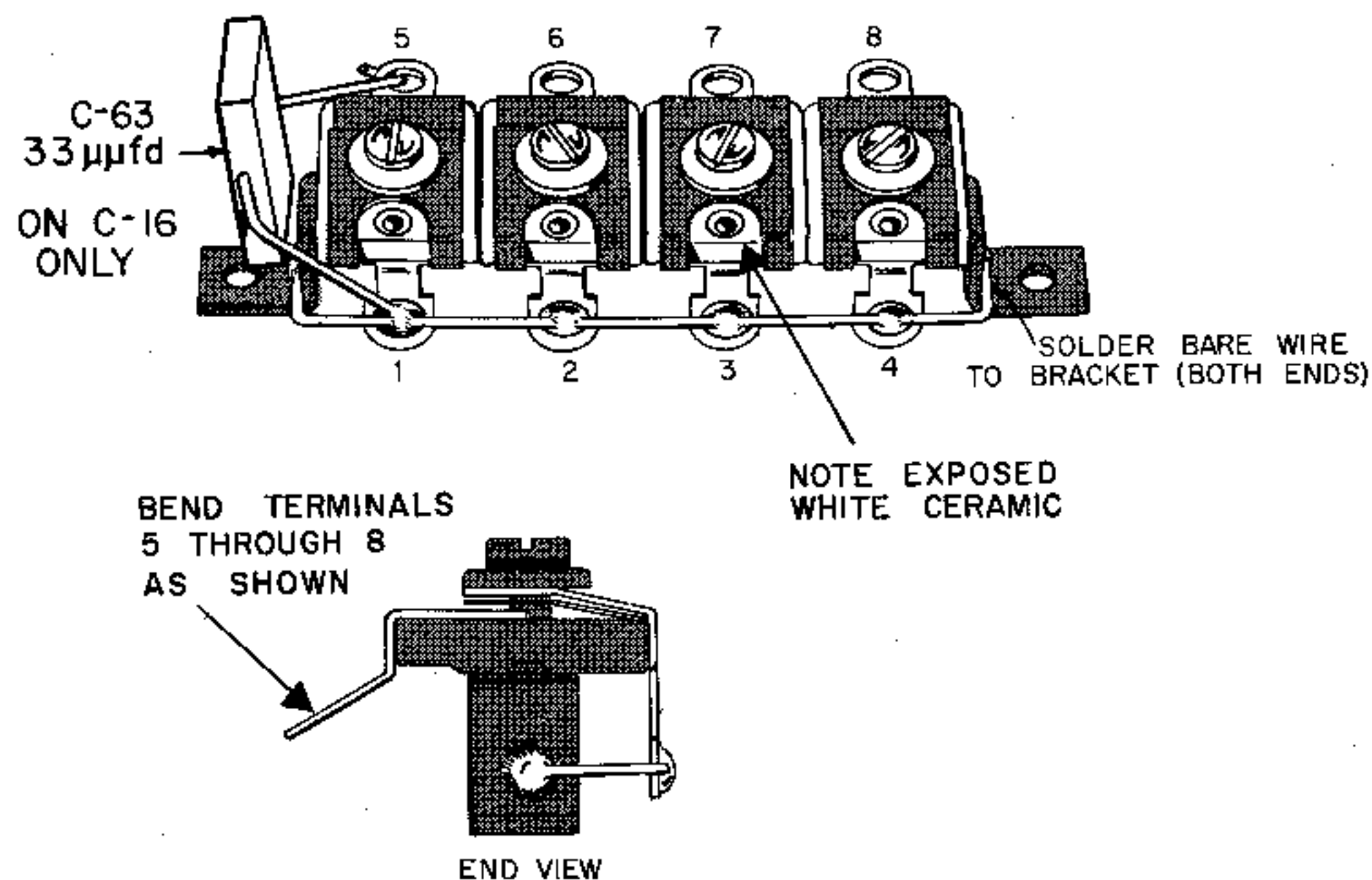

FIGURE 14. PREPARING THE TRIMMER STRIPS

HOW TO PREPARE AND INSTALL THE TRIMMER STRIPS

SEE FIGURE 14.

Two, identical trimmer strips are supplied. Each consists of four 3-30 $\mu\mu\text{fd}$ trimmers mounted on a bracket. Notice that terminals 1, 2, 3 and 4 on one side of each trimmer are just below the exposed white ceramic, as shown in Figure 14. These terminals must be properly identified and wired or the receiver will not work.

- Position one of the trimmers exactly as shown in Figure 14. This trimmer will be used as C-16.
- Solder one end of a 4" bare wire to one end of the bracket of the C-16 trimmer. Pass the wire along terminals 1, 2, 3 and 4. These are the terminals on the side which has exposed white ceramic. Solder the free end of the bare wire to the other end of the bracket.
- Solder the bare wire to terminals 2, 3 and 4 of C-16. Do not solder terminal 1.
- Solder one lead of C-63, a 33 $\mu\mu\text{fd}$ mica capacitor, to terminal 1 of C-16. Connect, but do not solder, the other lead of C-63 to terminal 5 of C-16.
- Position the other trimmer strip, C-12, exactly as shown in Figure 14.
- Solder one end of a 4" bare wire to one end of the C-12 bracket. Pass the wire along terminals 1, 2, 3 and 4. These are the terminals on the side which has exposed white ceramic. Solder the free end of the bare wire to the other end of the bracket.
- Solder the bare wire to terminals 1, 2, 3 and 4 of C-12.
- Bend terminals 5, 6, 7 and 8 of C-12 and C-16, as shown.

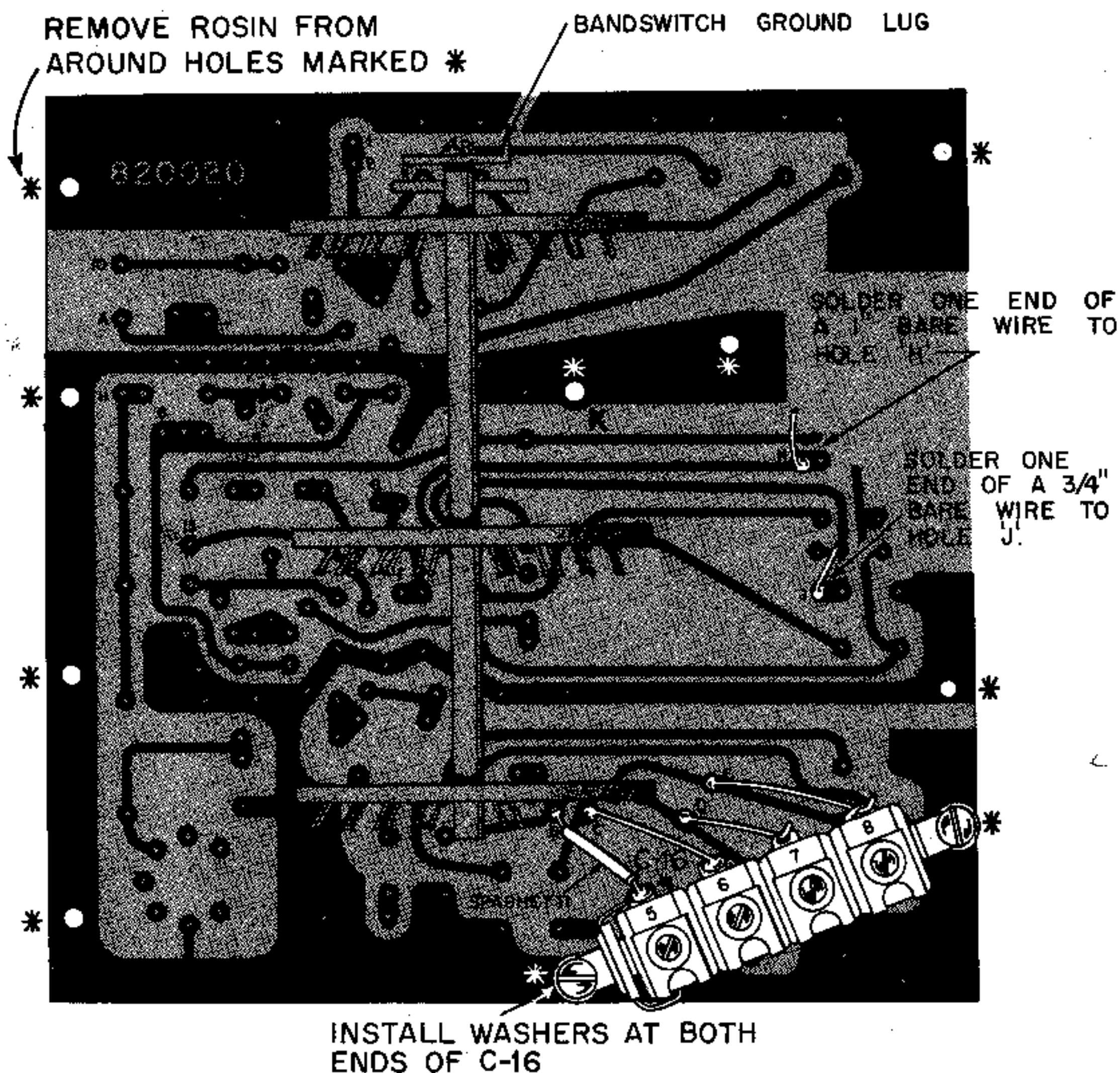

FIGURE 15. MOUNTING C-16 (TRIMMER STRIP)

SEE FIGURE 15.

- Good electrical contact between the foil side of the RF board and the RF subchassis is necessary for proper operation of your receiver. The foil side of the RF board may be coated with a protective layer of rosin. Remove it by lightly touching your hot soldering iron around the holes marked with an asterisk (*) as shown in Figure 15. The rosin will melt and a clean, shiny spot will appear.
- The bracket of C-16 (the trimmer strip with C-63 attached) must be raised from the RF board. To mount C-16 use the two 6-32 x 7/16" screws as follows: Insert each screw through a lockwasher, through the C-16 bracket, through two flat washers, and through the RF board. Tighten a nut over each screw.
- Solder one end of a 1 1/4" bare wire in hole C. Solder the other end to terminal 6 of C-16.
- Push a 1/2" piece of spaghetti over a 1" bare wire. Solder one end of this wire in hole B. Solder the other end to terminal 5 of C-16.
- Solder one end of a 1" bare wire in hole D. Connect, but do not solder, the other end to terminal 7 of C-16.
- Solder one end of a 1 1/2" bare wire in hole E. Connect, but do not solder, the other end to terminal 8 of C-16.
- Solder one end of a 1" bare wire in hole H. The other end will be connected later.
- Solder one end of a 3/4" bare wire in hole J. The other end will be connected later.

SEE FIGURE 16.

- ✓ Mount C-12 (the other trimmer strip) with one 6-32 x 5/16" screw, lockwasher, and nut. Position it as shown.
- ✓ Solder one end of a yellow wire in hole F. Solder the other end to terminal 5 of C-12.
- ✓ Connect, but do not solder, the free end of the 3/4" bare wire previously soldered in hole J to terminal 6 of C-12.
- ✓ Push 1" of spaghetti over each lead of C-19, a 10 μfd disc capacitor. Solder one lead to terminal 6 of C-12. Solder the other lead to terminal 7 of C-16.
- ✓ Trim a yellow wire to 3 1/2". Solder one end in hole G. Solder the other end to terminal 7 of C-12.
- ✓ Connect, but do not solder, the free end of the 1" bare wire previously soldered in hole H to terminal 8 of C-12.
- ✓ Push a 1 1/4" piece of spaghetti over each lead of C-18, a 3.3 μfd tubular capacitor marked with orange, orange, white color bands. Solder one lead of C-18 to terminal 8 of C-12. Solder the other lead to terminal 8 of C-16.
- ✓ Solder one end of a 3" bare wire to the foil as shown. Solder the other end to the BANDSWITCH ground lug.

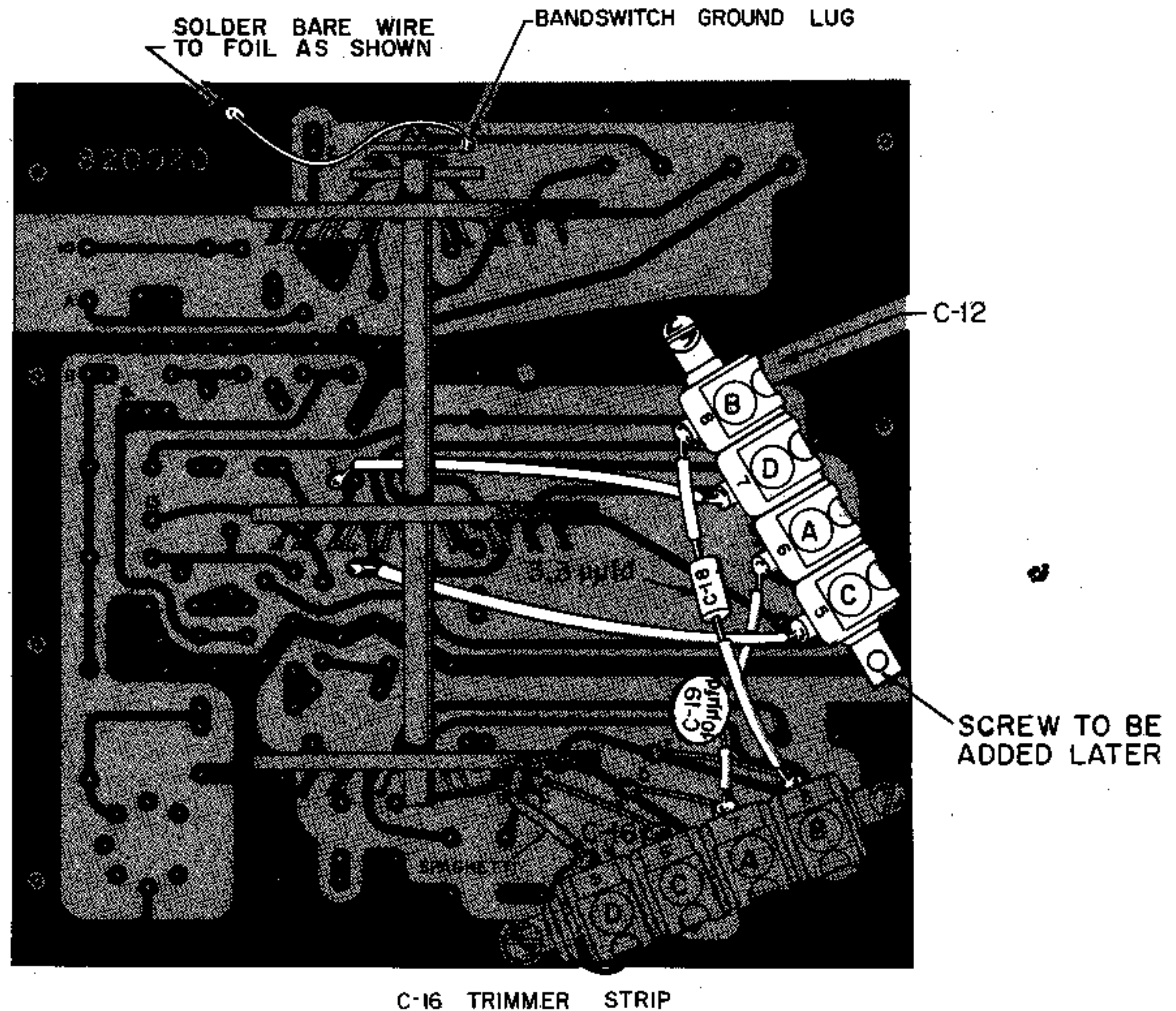

FIGURE 16. MOUNTING C-12 (TRIMMER STRIP)

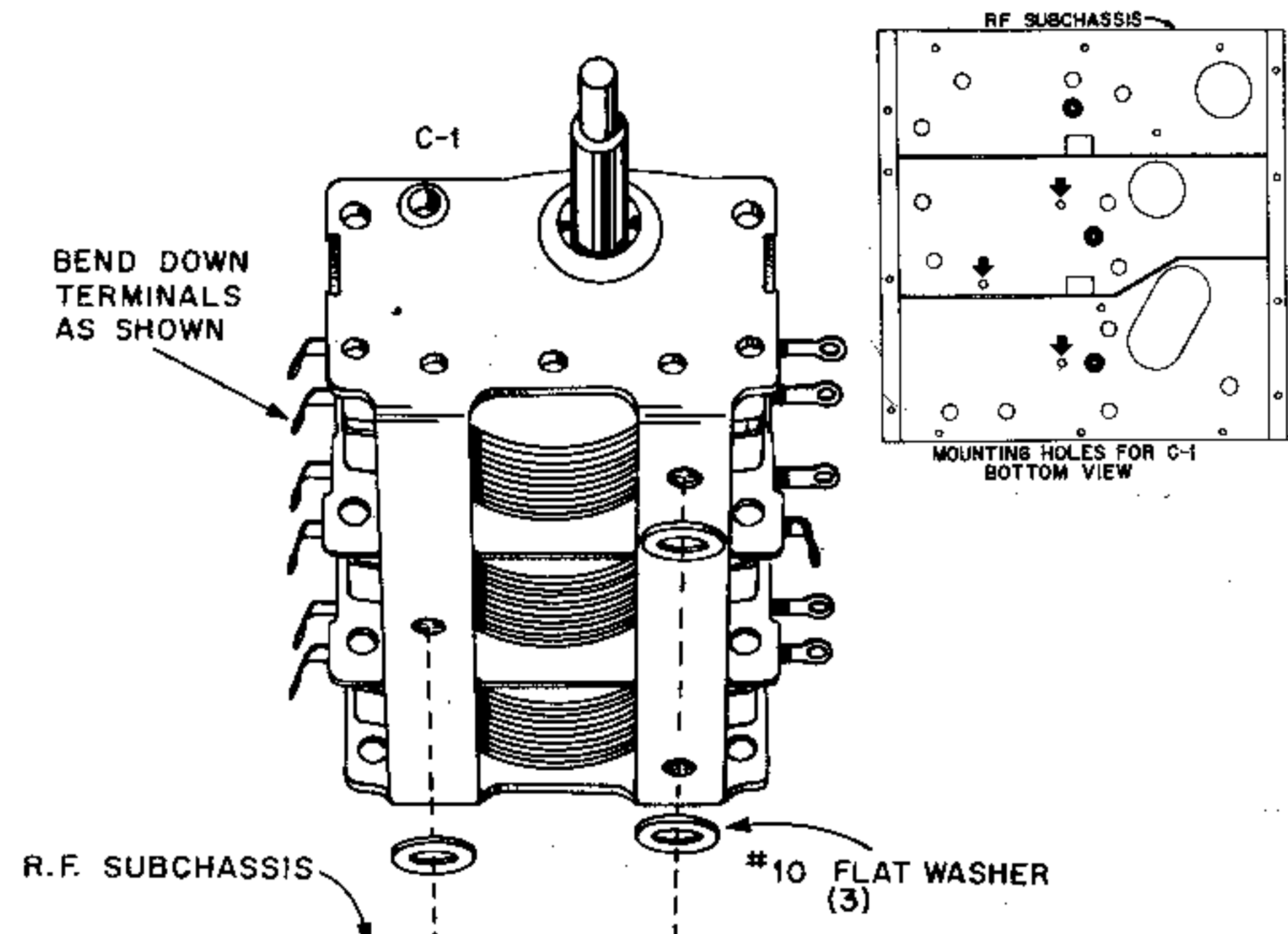

FIGURE 17. MOUNTING C-1 (MAIN TUNING CAPACITOR)

PARTS MOUNTING AND WIRING OF THE RF SUBCHASSIS

SEE FIGURE 17.

- ☑ Insert the three rubber grommets in the holes as shown.
- ☑ Close the plates of C-1, the MAIN TUNING capacitor, so they are fully meshed to protect them from damage. Bend the terminals of C-1 as shown.
- ☑ On top of the RF subchassis, mount C-1 with three roundhead 8-32 x 1/4" screws, lockwashers, and #10 flat washers. BE SURE THE FRAME OF C-1 IS PARALLEL TO THE EDGE OF THE CHASSIS.
- ☑ Attach a spade lug to the RF shield plate with a 6-32 x 5/16" screw, lockwasher, and nut as shown in Figure 18A.
- ☑ The RF shield plate also mounts on top of the RF subchassis. Refer to Figure 20 and the photograph on page 45 for the correct positioning of the shield plate. Use a lockwasher and a nut to mount it.

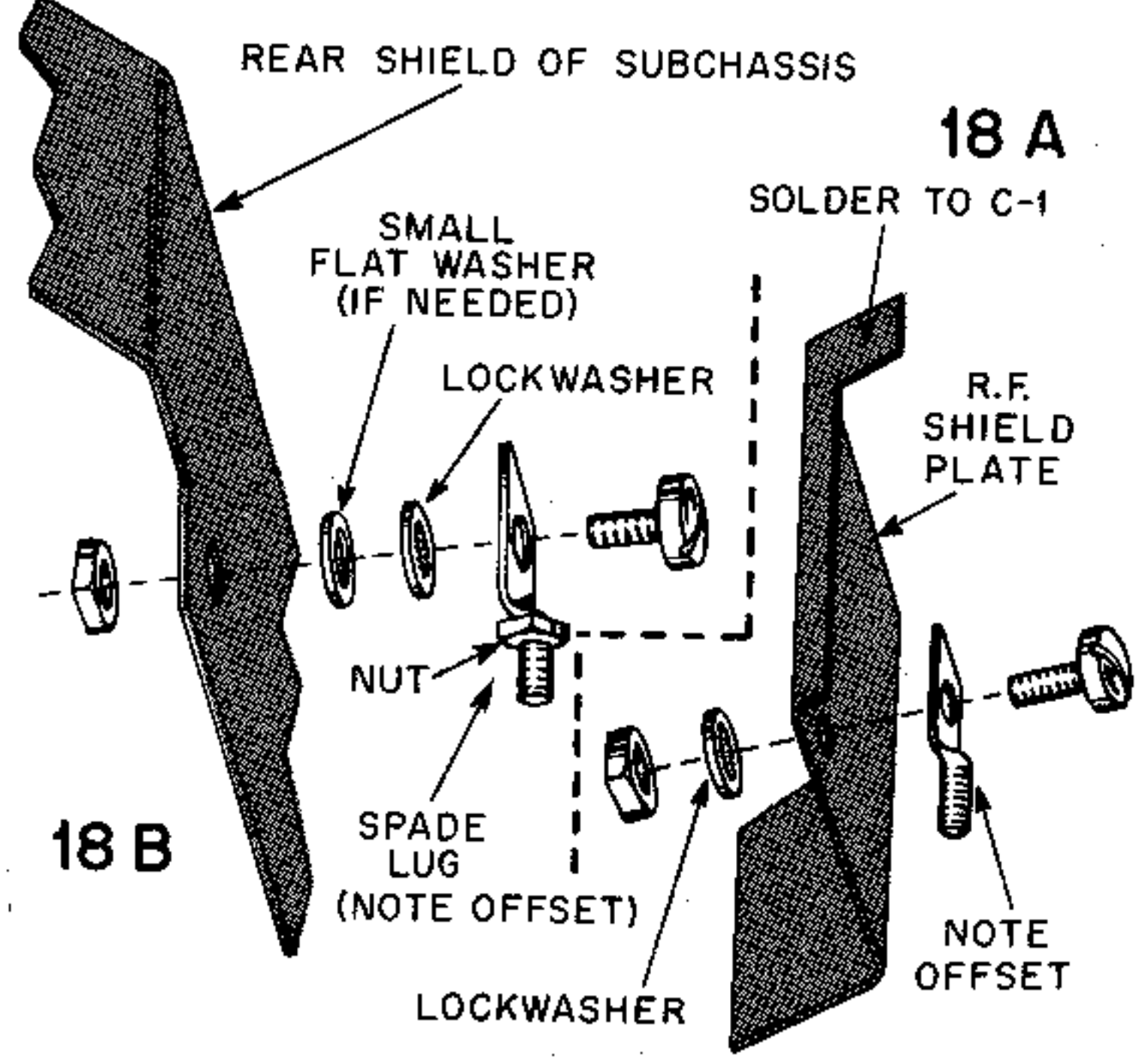
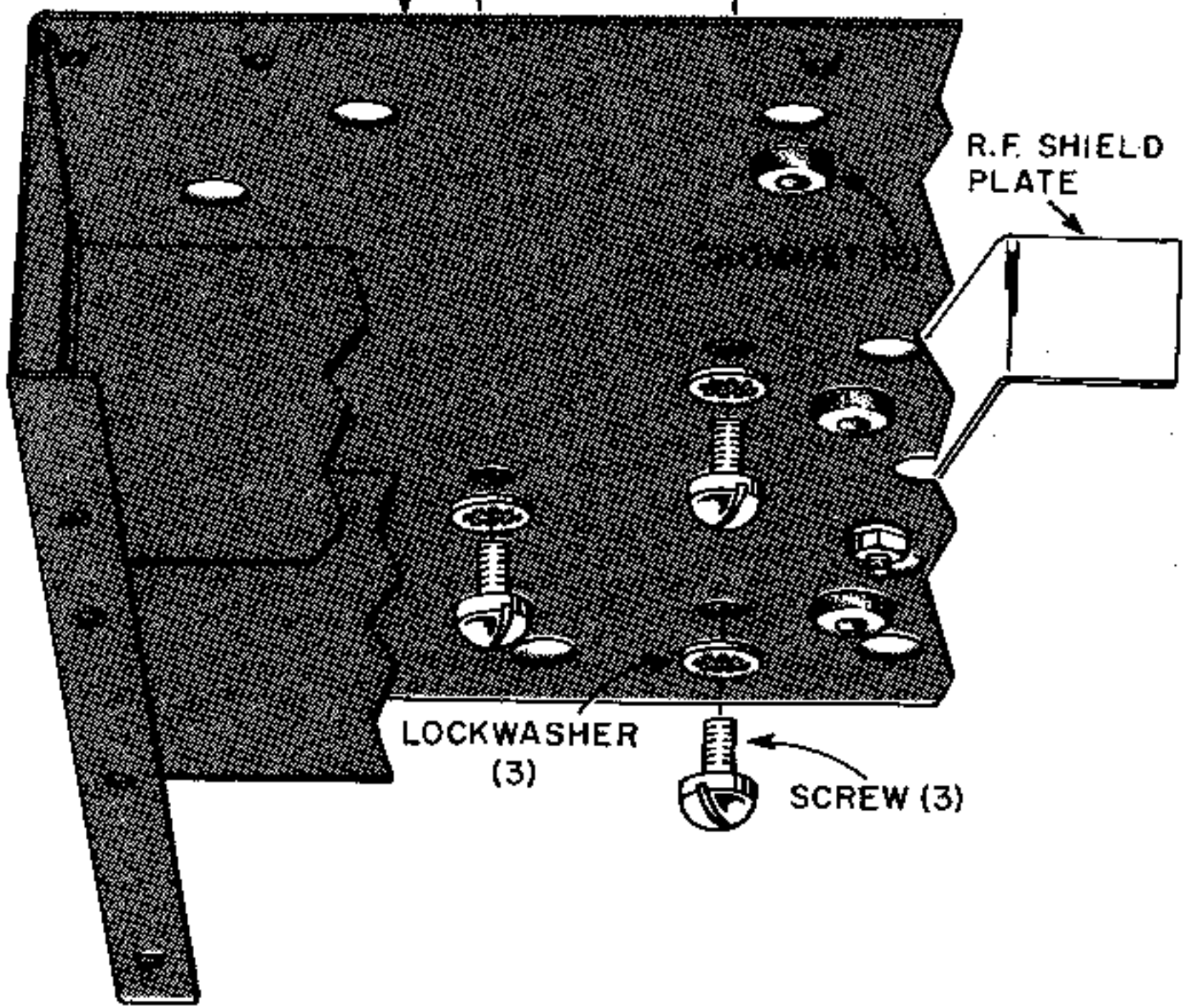

FIGURE 18. MOUNTING THE SPADE LUGS

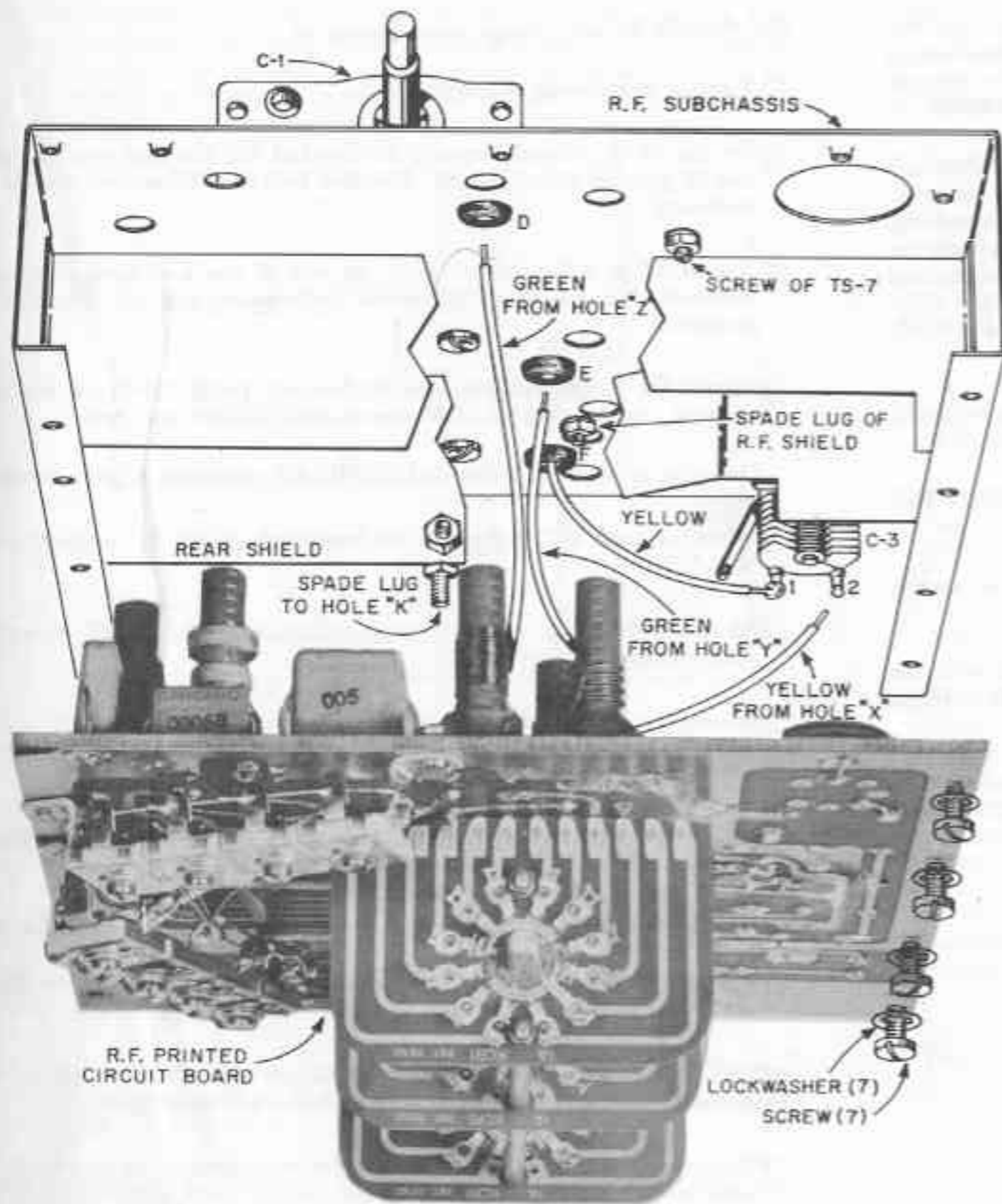

FIGURE 19. MOUNTING THE RF SUBCHASSIS

SEE FIGURE 19.

- Close the plates of C-3, the 80 μfd ANTENNA CONTROL, stamped 281016. From inside the RF subchassis, mount C-3 with the hardware supplied. Position the terminals as shown.
 - Solder one end of a yellow wire to terminal 1 of C-3. Pass the other end through grommet F. This end will be connected later.
 - Mount a spade lug on the rear shield of the RF subchassis. Use a 6-32 x 5/16" screw, lockwasher, flat washer, and nut as shown in Figure 18B. The lockwasher and the flat washer go between the spade lug and the shield. Position the spade lug as shown. Tighten a nut over the spade lug.
- TS-7 is a two-terminal strip with a separate mounting foot located between the two terminals. Do not confuse it with TS-6, a two-terminal strip which does not have a separate mounting foot.
- See Figure 20 on a separate sheet. Mount TS-7, a two-terminal strip, on the RF subchassis. Use a 6-32 x 5/16" screw, lockwasher and nut.
 - Position the RF printed circuit board and the RF subchassis as shown in Figure 19.
 - Pass the free end of the green wire previously soldered in hole Y through grommet E.
 - Pass the free end of the green wire previously soldered in hole Z through grommet D.
 - Align the spade lug (attached to the rear shield of the subchassis) so it fits through hole K. Remove the nut from the end of the C-16 bracket that is nearest terminal 8. Do NOT lose the washers. Attach the board to the subchassis with seven 6-32 x 5/16" screws and lockwashers.
- If the mounting holes on the printed circuit board do not align with the threaded holes on the subchassis, remove or add a flat washer in the mounting of the spade lug as shown in Figure 18B.
- Fasten the printed circuit board to the spade lug with a lockwasher and a nut.
 - Solder the free end of the yellow wire coming from hole X to terminal 2 of C-3.

RESISTANCE CHECKS ON THE RF PRINTED CIRCUIT BOARD

If you have an ohmmeter, check the resistance between ground and the following test points on the RF printed circuit board. (These measurements are to be made without the tubes in place.) A convenient point for ground connection is the copper-covered corner of the board stamped "820020".

Experience in kit building shows that wrong resistance readings are usually caused by "cold" solder connections, connections left unsoldered, using too much solder on the printed circuit board, mounting a component at the wrong holes or wrong mounting of the coils. Carefully recheck the whole wiring of the RF printed circuit board, especially the mounting and soldering of the bandswitch to the board and the mounting of the coils. If in doubt about a soldered connection, heat the connection again and apply a little more solder.

- Between ground and hole 6, the meter should indicate an open circuit. This checks for short-circuits in the filament circuits of V-1 and V-9.
- Between ground and hole 11, the meter should indicate 800K Ω . This checks for short circuits and continuity in the B+ circuit.
- Between ground and hole 10, the meter should indicate an open circuit. This checks for short circuits in the AVC line.
- Between ground and hole 2, the meter should read under 40 Ω , with the BANDSWITCH in the A, B, C, or D position. This tests the antenna circuit.
- Between ground and the green wire from hole Z on the component side, the meter should indicate open circuit, except in BANDSWITCH position D, where the ohmmeter should read less than 1 Ω . This checks the oscillator tuning circuit.

PARTS MOUNTING AND WIRING ON TOP OF THE CHASSIS

SEE FIGURE 20 on a large separate sheet.

- Position the chassis as shown.
- On top of the chassis, mount the bracket for the dial crystal close to the IF printed circuit board. Use two 6-32 x 5/16" screws, lockwashers and nuts.
- Mount TS-6, a 2-terminal strip, on one of the L-shaped dial support brackets. Use a 6-32 x 5/16" screw, lockwasher, and nut. Position TS-6 as shown.
- Mount the L-shaped dial support bracket (with TS-6) on top of the chassis. Use two 6-32 x 5/16" screws, lockwashers, and nuts.

Close the plates of C-2, the BANDSPREAD capacitor, to protect them.

- Slide the shaft of C-2 through the lower hole in the dial support bracket with TS-6.
- Mount C-2 on top of the chassis with three 6-32 x 5/16" screws and lockwashers.
- Mount the vernier drive in the large lower hole of the other L-shaped dial support bracket. Use two 6-32 x 5/16" screws, one lockwasher, one solder lug, and two nuts.
- Mount this dial support bracket loosely on top of the chassis. Use two 6-32 x 5/16" screws, lockwashers, and nuts.

CAUTION: Keep the plates of C-1 closed during the following steps.

- Slip one collar of a shaft coupler on the shaft of C-1. Tighten the set-screw slightly.

NOTE: When you place the RF subchassis into position, be sure the 9-conductor cable is out of the way so S-4 is not damaged.

- Place the main chassis over the subchassis assembly, as shown. Lift the subchassis into position, and slip the vernier drive into the other collar of the shaft coupler. Fasten the subchassis to the main chassis with twelve 6-32 x 5/16" screws and lockwashers. Two of these screws also fasten the left dial crystal bracket to the main chassis.

✓ Loosen the setscrew on the C-1 end of the shaft coupler and align this part on the two shafts. Tighten both setscrews.

✓ Be sure the shaft of C-1 and the shaft of the vernier drive are in line. That is, one shaft must not be either higher or lower, or to the right or left of the other, as illustrated below. If the shafts do not line up, loosen the vernier drive screws and the dial support bracket screws and reposition so the shafts are perfectly in line. Tighten the screws.

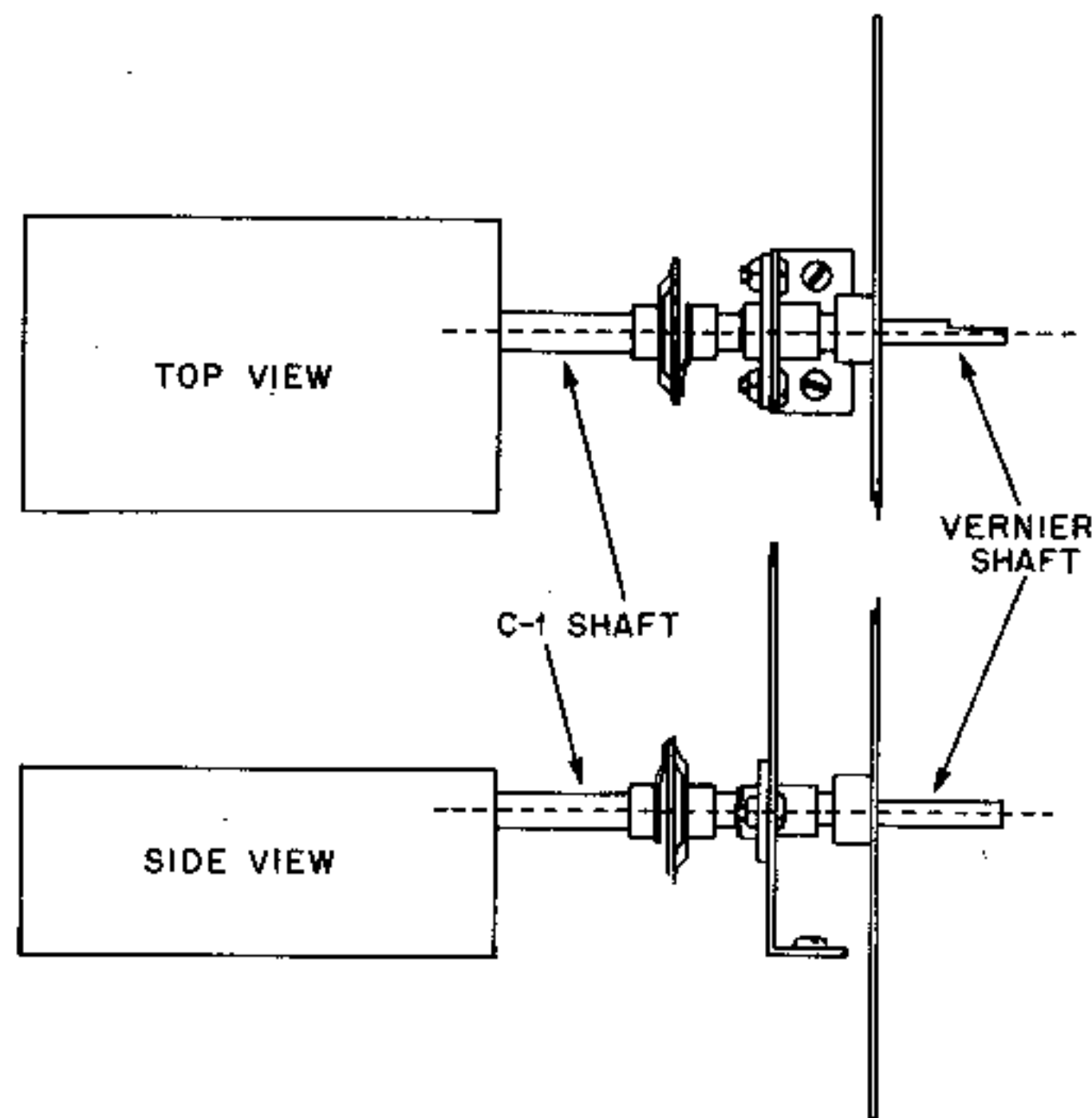

FIGURE 20A. SHAFT ALIGNMENT

✓ Solder one end of a 1½" bare wire to terminal 3 of C-1. Connect, but do not solder, the other end to terminal 2 of TS-7.

✓ Connect, but do not solder, one lead of C-10, a 200 μfd (.0002) mica capacitor, to terminal 2 of TS-7. Connect, but do not solder, the other lead to terminal 1 of TS-7.

✓ Solder one end of a red wire to terminal 1 of TS-7. Solder the other end to terminal 1 of C-2.

✓ Trim the green wire coming through grommet D to the correct length to connect to terminal 2 of TS-7. Solder it to terminal 2.

✓ Trim the green wire coming through grommet E to the correct length to connect to terminal 2 of C-1. Connect, but do not solder, it to terminal 2.

✓ Solder one end of an orange wire to terminal 2 of C-1. Solder the other end to terminal 2 of C-2.

✓ Solder the yellow wire coming through grommet F to terminal 1 of C-1.

✓ Solder the top of the RF shield plate to the frame of C-1 as shown.

✓ From the component side of the IF board, insert one end of a white-red wire in hole A. (Solder it on the foil side.) Route it as shown. Connect, but do not solder, the other end to terminal 1 of TS-6.

✓ Before mounting the MAIN TUNING and BANDSPREAD dials, be sure there is a setscrew in the hub of each dial.

✓ Slip the BANDSPREAD dial (with five scales of numbers printed on it) over the shaft of C-2. DO NOT tighten the setscrew of the dial.

✓ Slip the MAIN TUNING dial (with four scales of numbers printed on it) over the long thin shaft of the vernier drive. DO NOT tighten the dial setscrew.

✓ Attach the dial crystal to the two dial crystal mounting brackets. Use four 3-48 x ¼" screws and nuts.

✓ Turn the shaft of C-1 fully counterclockwise so the plates are fully closed. Push the MAIN TUNING dial as close as possible to the dial crystal without letting the dial touch the bracket. Align the hairline at the low frequency end of the dial with the hairline on the crystal. Tighten the setscrew.

✓ Turn the BANDSPREAD capacitor shaft fully counterclockwise so the plates are fully closed. Push the BANDSPREAD dial as close as possible to the dial crystal without letting the dial touch the bracket. Align the hairline at the low frequency end of the dial, with the hairline on the crystal. Tighten the setscrew.

For accurate hairline alignment for both MAIN TUNING and BANDSPREAD dials, it may be necessary to readjust the position of the dial crystal.

SEE FIGURE 21 on a large separate sheet.

- Position the chassis as shown.
- Put one of the collars of a shaft coupler on the shaft of the BANDSWITCH.
- Put the BANDSWITCH shaft assembly together as shown in Figure 22. After the "C" washers are in the grooves crimp them so they don't fall off.

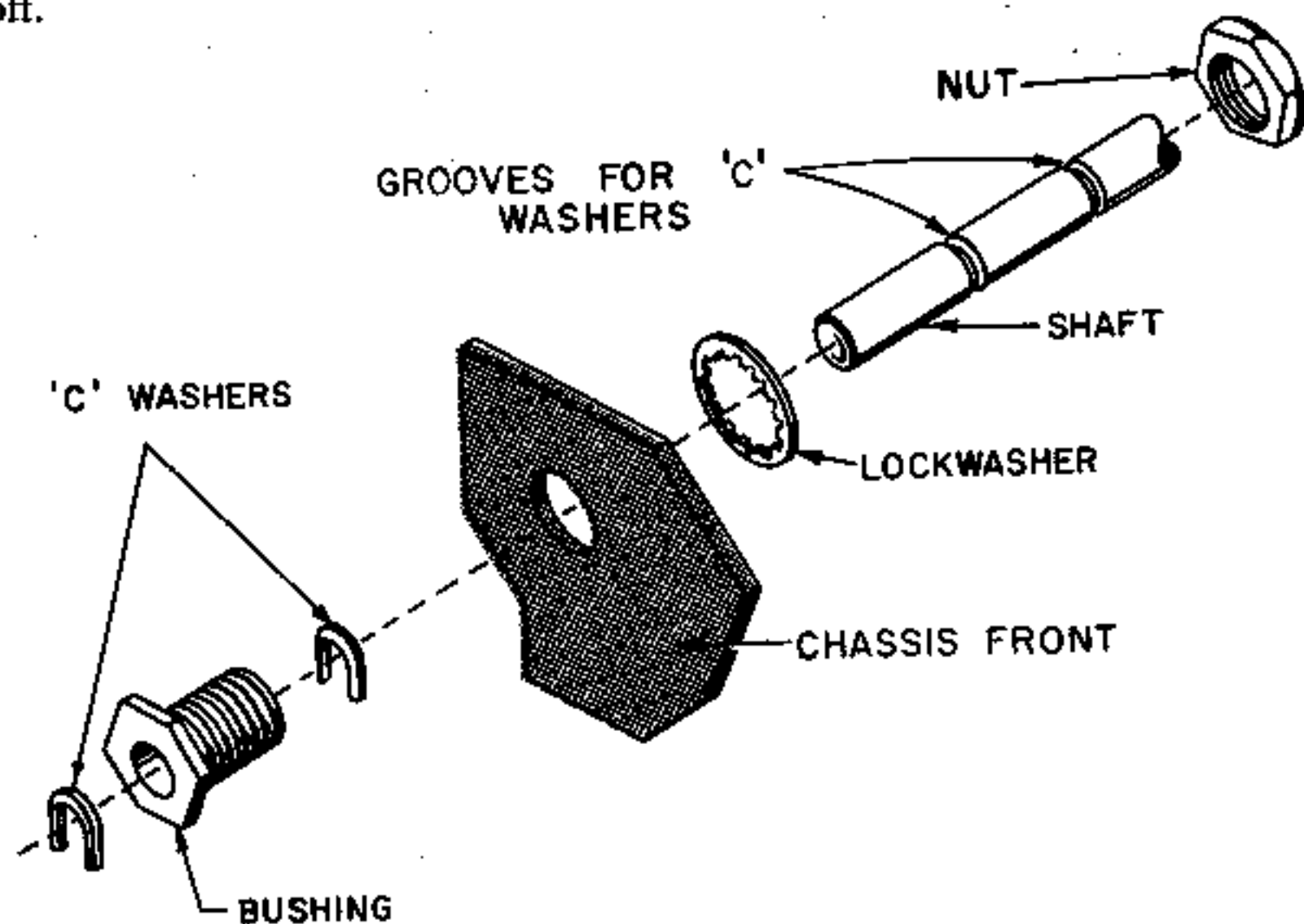

FIGURE 22. BANDSWITCH SHAFT ASSEMBLY

- Mount the BANDSWITCH shaft assembly on the front of the chassis. Use a $\frac{3}{8}$ " lockwasher and nut in the same manner as used to mount the other controls and switches. Be sure to insert the shaft end into the other collar of the shaft coupler. Tighten the setscrews on both collars.
- Solder the free end of the orange wire previously soldered to the coaxial antenna jack, J-1, in hole 1 on the RF printed circuit board.
- Solder one end of a red wire to terminal 1 of TS-1. Solder the other end in hole 2 of the RF printed circuit board.
- Solder one end of a violet wire in hole 10 on the RF printed circuit board. Solder the other end in hole 10 on the IF printed circuit board.

- Solder one end of a blue wire in hole A on the RF printed circuit board. Solder the other end in hole A on the IF printed circuit board.
- Solder one end of a violet wire in hole 6 on the RF printed circuit board. Solder the other end in hole 6 on the IF printed circuit board.
- Solder one end of a violet wire in hole 11 on the RF printed circuit board. Solder the other end in hole 11 on the IF printed circuit board.
- Prepare a 7" insulated shielded wire as shown in Figure 9B, but do not use any bare wire.
- Solder the inner conductor of this 7" wire (the end with $\frac{1}{4}$ " braided shielding exposed) in hole 13 on the IF printed circuit board. Solder the other end of the inner conductor in hole 13 on the RF printed circuit board.
- There is a bare wire soldered to the wire previously soldered to hole 15. Position this bare wire as shown. Being careful not to melt the inner insulation, solder the bare wire to the shielding of the wire previously soldered into hole 13. Now, solder the loose end to the solder lug near the IF printed circuit board.

Before mounting the output transformer, T-1, prepare the blue and red leads as follows:

- Clip both the blue and red leads to 4". Remove $\frac{1}{4}$ " of insulation from the end of each lead. Prepare the end of both leads by twisting the stranded bare wires tightly and coating with solder.
- Push the 2 $\frac{1}{2}$ " piece of shielding over the blue lead. NOTE: The shielding MUST be as close as possible to the bare end of the blue lead, but not so close that it will touch the foil of the printed circuit board when the blue lead is connected. Be careful NOT to melt the blue insulation, and coat both ends of the shielding with solder. Do not overheat!
- From inside the chassis, mount T-1. Use two 6-32 x 5/16" flat-head screws, one lockwasher, one solder lug, and two nuts. Note that the chassis holes are countersunk for these flat-head screws.
- Solder the T-1 red lead in hole 25 on the IF printed circuit board. Solder the T-1 blue lead in hole 26 on the IF printed circuit board.
- Solder one end of a 2 $\frac{1}{2}$ " bare wire to hole 34 on the IF printed circuit board. Be careful not to melt the blue insulation, and solder the other end of the bare wire to the end of the braided shield of the T-1 blue lead as shown. NOTE: THIS BARE WIRE MUST BE SOLDERED VERY CLOSE TO THE END OF THE BRAIDED SHIELD CLOSEST TO THE IF PRINTED CIRCUIT BOARD. IF THE WIRE IS NOT SOLDERED TO THIS END OF THE BRAIDED SHIELD, A GROUND LOOP WILL BE SET UP AND OSCILLATIONS MAY RESULT.

- Connect, but do not solder, either one of the two thin leads of T-1 to the solder lug which was mounted with T-1.
- Solder one end of a yellow wire in hole 33 on the IF printed circuit board. Solder the other end to the solder lug which was mounted with T-1.
- Push a 3" piece of spaghetti over the other thin lead of T-1. Now solder this lead to terminal 3 of the phone jack, J-2.

FINAL PARTS MOUNTING AND WIRING

SEE FIGURE 23 on a large separate sheet.

- Turn the receiver right-side-up.
- Install I-1, the MAIN TUNING dial light in a socket. Snap the socket into position as shown by squeezing the two tabs against the socket and catching them in the notches on the dial support bracket, while releasing pressure.
- Cut the black I-1 lead to 4". Solder the black I-1 lead to the solder lug mounted on the MAIN TUNING dial support bracket. Cut the red lead to 6" and connect, but do not solder, it to terminal 1 of TS-6.
- In a similar manner, install I-2 in the other socket and snap I-2 into the notches in the BANDSPREAD dial support bracket.
- Cut the red and the black I-2 leads to 4". Solder the black I-2 lead to terminal 2 of TS-6. Solder the red I-2 lead to terminal 1 of TS-6. Route both leads as shown.

SEE THE PHOTOGRAPH ON FRONT COVER

The panel marking strips are to be assembled to the front panel.

- Insert the heads of three 4-36 x 3/8" screws into the groove of each panel marking strip. Position these screws so they align with the holes in the front panel.

- Mount the panel strip marked OFF-STBY-RCV-CAL etc. on the front panel. Fasten the strip with three #4 nuts.
- In a like manner, mount and fasten the panel strip marked RF GAIN, etc. on the front panel.
- In a like manner, mount and fasten the unmarked panel strip on the front panel.

Tip the receiver back so the front of the chassis is up.

- Place the front panel on the receiver so all the shafts are through the holes. Fasten the panel with a 25/64" flat washer and a nut on each of the following controls: ~~OFF-STBY-RCV-CAL~~; ~~RF GAIN~~; ~~AF GAIN~~; and ~~BFO-MVC-AVC-ANL~~.
- Put knobs on the shafts of the following controls. Tighten each knob set-screw against the flat on the shaft.

OFF-STBY-RCV-CAL ✓

PEAK-OFF-NULL ✓

BFO-MVC-AVC-ANL ✓

- Turn the shafts of the following controls all the way to the left. Position the white dot on the knob toward the lower left corner of the panel, and tighten each setscrew.

RF GAIN ✓

QX SELECTIVITY

AF GAIN

- Turn the shaft of the BFO control so the plates of the capacitor are half open. Put a knob on this shaft, and position the white dot on the knob at the middle reference line on the panel. Tighten the setscrew.
- Turn the shaft of the QX TUNE control fully counterclockwise so the capacitor plates are fully open. Push the red pointer over the copper shaft of the QX TUNE control so the pointer points directly to the left. Put a knob on the vernier shaft (end section of the shaft). Tighten the setscrew.
- Turn the shaft of the A-B-BAND-C-D switch all the way to the left. Position the white dot on the knob at A, and tighten the setscrew.

Again place the receiver in the upright position.

- Push a large knob on both the MAIN TUNING and BANDSPREAD dial shafts.

- Assemble the ANTENNA CONTROL shaft and bushing as shown in Figure 24. After the "C" washers are in the grooves, crimp them so they don't fall off.

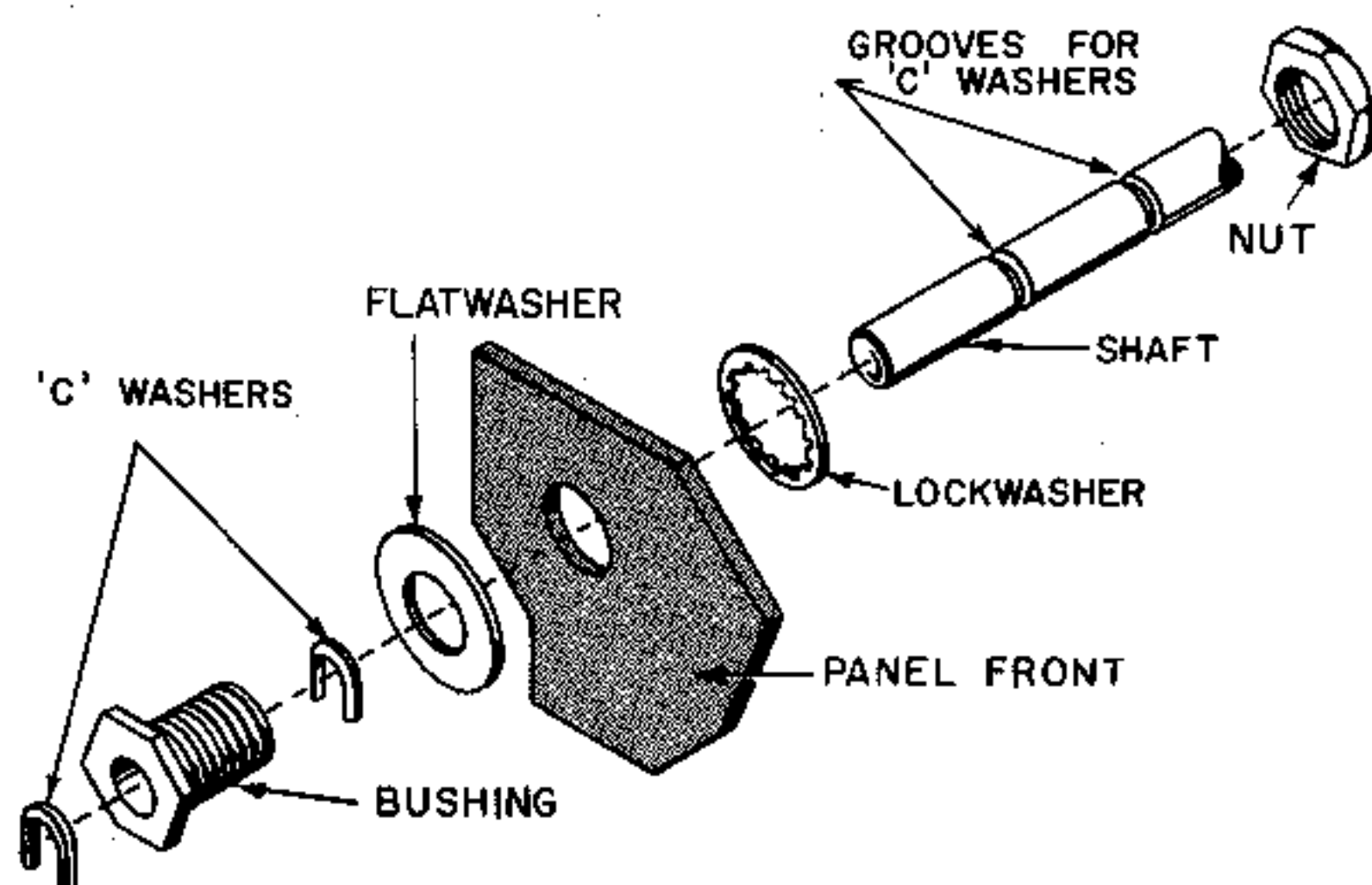

FIGURE 24. ANTENNA CONTROL ASSEMBLY

- Insert two #8 setscrews into each collar of the flexible metal shaft before you mount it.
- Mount the ANTENNA CONTROL shaft assembly on the front panel. Slip the collar at one end of the shaft coupler over the shaft of the ANTENNA CONTROL shaft assembly. Tighten the setscrews. Slip the collar at the other end of the flexible metal shaft over the shaft of C-3. Tighten the setscrews. Push the small red knob on the shaft of the ANTENNA CONTROL, and tighten the setscrew.
- Snap the fuse, F-1, into the cap, and tighten the cap on the fuseholder.
- Turn the RF GAIN and AF GAIN controls fully counterclockwise.
- Turn the OFF-STBY-RCV-CAL switch to the OFF position.

DO NOT TOUCH ANY OF THE WIRING WHILE THE RECEIVER IS PLUGGED INTO A POWER OUTLET.

- Plug the receiver into an AC outlet, supplying 110-120 volts, 50-60 cycles AC. (If you are in doubt about the type of power you have, consult your local electric company before plugging in the receiver.)

- Turn the OFF-STBY-RCV-CAL switch to the STBY position. The two dial lights should light. Now switch to RCV and CAL. The dial lights should be on in these switch positions also.
- Turn the OFF-STBY-RCV-CAL switch to the OFF position.
- Refer to the photograph on page 45. Install V-1, V-2, V-3, V-4, V-5, V-6, V-7 and V-8 in their sockets. The rectifier tube, V-9, will be installed later.
- Turn the OFF-STBY-RCV-CAL switch to the STBY position. Check to see that the filaments light in tubes V-1, V-2, V-4 through V-8. There will be no light in V-3, the voltage regulator tube.
- Turn the OFF-STBY-RCV-CAL switch to the OFF position.
- Install V-9 in its socket. Turn the OFF-STBY-RCV-CAL switch to STBY. Check to see that V-3 glows. Turn the switch back to OFF.

Notice that the tube shields are three different lengths.

- Slide the medium length tube shield over V-1. Press the tube shield down so it makes contact with the ground clip.
- Slide long tube shields over V-2 and V-8. Press the tube shields down to make contact with the ground clips.
- Slide short tube shields over V-4, V-5, V-6 and V-7.
- Connect a speaker or headphones, whichever you prefer. If you use a speaker, connect the two leads of an 8-ohm permanent-magnet speaker to the two terminals marked 8-ohm SPKR on the rear of the chassis. If you use headphones, insert the plug of the headphones into the jack marked PHONES on the front panel. The speaker outlet is automatically disconnected when the headphones are plugged in.

If you have already purchased the S-Meter kit, or the Crystal Calibrator kit, they should be installed at this time. See pages 34-36 for installation instructions.

PRELIMINARY TESTS

If a voltmeter (VTVM or a 20,000 ohms/volt VOM) is available, use the + DC volt scales, set the receiver controls as follows, and make the following measurements: Refer to Figure 21. If any of the measurements do not correspond (within $\pm 20\%$), recheck the wiring and soldering, and be sure the components are not shorting together or to the chassis.

OFF-STBY-RCV-CAL	RCV position
RF GAIN	Full clockwise
A-B-BAND-C-D	Position A
PEAK-OFF-NULL	OFF position
AF GAIN	Full counterclockwise
BFO-MVC-AVC-ANL	MVC position

Stand the receiver on its back.

- Between ground and hole 18 of the IF printed circuit board, the meter should read 183 v.
- Between ground and hole 26 of the IF printed circuit board, 180 v.
- Between ground and hole 13 on the RF printed circuit board, 180 v.
- Between ground and hole 37 of the IF printed circuit board, 2.5 v.
- Between ground and hole A on the RF printed circuit board, 1.0 v. Now, turning the RF GAIN control slowly counterclockwise, the meter should read from 1.0 v through 15 v.
- Connect an antenna to the terminal marked "A". If you use a coaxial antenna lead in, connect it to J-1. Connect a ground wire to the terminal marked "G".

Set the controls as follows:

RF GAIN	Full clockwise
BFO-MVC-AVC-ANL	AVC position
BANDSPREAD TUNING	Full clockwise
(Check that the hairline on the high-frequency end of the BAND-SPREAD dial coincides with the hairline on the crystal.)	
AF GAIN	Half clockwise

- Use the MAIN TUNING control to tune in a standard broadcast station. You should be able to hear strong local stations. Now tune through the range with the bandswitch in the B, then the C and D positions. If noise and some type of signal are heard on each band the receiver is ready for alignment. However, if any band sounds "dead" DO NOT ATTEMPT TO ALIGN THE RECEIVER. Read the service hints and correct any fault before proceeding with the alignment.

ALIGNMENT PROCEDURE

Two methods of receiver alignment are outlined in this section: Alignment using signal generator and meter; and alignment "on the air". The most accurate alignment can be achieved by using a signal generator and meter. If it is not possible to obtain the use of these instruments, the receiver can be aligned by the methods outlined in the section "Alignment On The Air." To obtain the full sensitivity of the receiver, accurate alignment is necessary.

CAUTION: DO NOT ATTEMPT TO ADJUST COILS L-1 THROUGH L-12 IF ANY BAND OF THE RECEIVER SOUNDS "DEAD". THE COILS ARE PRE-ALIGNED AND ONLY SLIGHT ADJUSTMENT IS NEEDED FOR ALIGNMENT.

ALIGNMENT USING SIGNAL GENERATOR AND METER

The meter used can be the built-in S-Meter, if you have one, or any VTVM or a volt-ohmmeter with at least 5000 Ω per volt AC sensitivity.

If you are using the S-Meter, connect your speaker or plug in your headphones. If you use a VTVM or VOM, remove the headphone plug because it opens the circuit to the speaker terminals. Connect the VTVM or VOM across the speaker terminals. (Ground lead goes to terminal G.)

Turn the receiver to RCV and listen for random noise to be sure that the receiver is ready for alignment. Disconnect the antenna.

IF ALIGNMENT

- Short out the oscillator section of the MAIN TUNING capacitor by connecting a wire between chassis and terminal 3 of the MAIN TUNING capacitor. See Figure 20.

Set controls as follows:

BFO-MVC-AVC-ANL	AVC (if you use the S-Meter)
	MVC (if you use an external meter)
AF GAIN	Fully clockwise (Reset later when necessary)
RF GAIN	Fully clockwise
PEAK-OFF-NULL	OFF
A-B-BAND-C-D	A
MAIN TUNING capacitor	Plates fully meshed
BANDSPREAD capacitor	Plates fully meshed

- Raise the tube shield of V-2, the 6BH8 oscillator tube, about 1" above the tube. Be careful not to short the tube shield against the chassis. Set the signal generator at 455 kc modulated output, using the maximum output available. Connect the generator output cable to the tube shield of V-2.

THROUGHOUT THE ALIGNMENT PROCEDURE, AS THE OUTPUT INCREASES, REDUCE GENERATOR OUTPUT TO THE LOWEST NEEDED FOR AUDIBILITY, TO AVOID OVERLOADING YOUR RECEIVER.

NOTE: The IF transformer slugs fit tightly. When you use the alignment tool, be careful not to chip out the slots into which the tool fits.

- Use the IF alignment tool with screwdriver tip supplied with your kit. Adjust the IF transformers for maximum meter reading. Start with Z-3 (top and bottom); then adjust Z-2 (top and bottom) and Z-1 (top and bottom). Repeat in the same order until no further gain is obtained. When the IF stages are close to alignment, an appreciable amount of noise will be heard because of the high sensitivity of the receiver.
- Reseat the oscillator tube shield. Remove the grounding wire, which was temporarily connected to terminal 3 of C-1.
- Mount the four rubber feet to the bottom plate with four 6-32 x 5/16" screws, four lockwashers and four nuts. Mount the bottom plate to the bottom of the chassis with six 6-32 x 5/16" screws, and six lockwashers. Notice that the trimmer holes in the bottom plate are opposite the C-12 and C-16 trimmer strips.

HIGH FREQUENCY OSCILLATOR, RF AND MIXER ALIGNMENT

- Turn the bandspread capacitor fully clockwise (plates fully open). This is essential for correct calibration.

The other receiver controls remain in the same position as for IF alignment, except for the A-B-BAND-C-D switch which will be used in each of the four positions.

- Connect the output lead of the signal generator to a 300-500 $\mu\mu\text{fd}$ capacitor. Connect the other end of the capacitor to the antenna input of the receiver.

Note: Because adjustments at the high and low ends of the band affect each other, repeat each alignment step until no further gain is obtained. Follow the exact order given in the alignment chart. Adjust only the trimmer at the high end; adjust only the coil at the low end. All adjustments are made for maximum meter reading and loudest receiver output.

SEE THE ALIGNMENT CHART ON THE NEXT PAGE.

Step 1. Band A Oscillator Alignment

- Set the receiver bandswitch at A. Set the tuning dial of the receiver and signal generator EXACTLY at 1.65 mc. Use the screwdriver-tip alignment tool to adjust C-16A for maximum meter reading and loudest output.
- Set receiver and generator dials EXACTLY at .55 mc. Use the hex-tip alignment tool to adjust L-1 for maximum. Only a slight adjustment is needed because the coils are pre-aligned.
- Repeat step 1, following the exact order given in the chart.

Step 2. Band A RF and Mixer Alignment

- Set the receiver dial exactly at 1.4 mc, the generator at approximately 1.4 mc. Slowly "rock" the generator dial (a little to the right, then a

little to the left) to find the generator setting that produces maximum receiver output. Adjust C-12A, then C-3, the ANTENNA control.

- Set receiver exactly at .6 mc, generator approximately at .6 mc. "Rock" the generator dial to find the setting that produces maximum receiver output. Adjust L-9 then L-5 for maximum. Very slight adjustment is needed.
- Repeat step 2, following the exact order listed in the chart.

Step 3. Band B Oscillator Alignment

- Set bandswitch at B, receiver and generator EXACTLY at 4.6 mc. Adjust C-16B for maximum.
- Turn generator to 3.69 mc and turn up generator output to check for an image frequency (receiver still at 4.6 mc). If no signal is heard at the receiver, C-16B is correctly adjusted. However, if a signal is heard, C-16B is incorrectly adjusted to the wrong side of the signal frequency. To correct the adjustment, turn the signal generator dial to 4.6 mc. A signal will still be heard. Now turn C-16B counterclockwise. The signal will become fainter, then inaudible. As you continue to turn C-16B counterclockwise the signal will be heard again and will reach a new maximum. At this point the oscillator is correctly adjusted to the high side.
- Set receiver and generator EXACTLY at 1.6 mc. Adjust L-2 for maximum.
- Repeat the entire step 3.

Step 4. Band B RF and Mixer Alignment

- Perform step 4 as shown in the alignment chart. As in step 2, "rock" the generator dial for maximum receiver output before adjusting C-12B and C-3 on the high end of the dial, or L-10 and L-6 at the low end of the dial. Repeat step 4.

Step 5. Band C Oscillator Alignment

- Set receiver and generator at the exact frequency shown in the chart and make the indicated adjustments. Check for an image by setting the receiver at 12.4 mc, generator at 11.49 mc. If no signal is heard, C-16C is correctly adjusted. If a signal is heard, set the generator dial at 12.4 mc and turn C-16C counterclockwise until a new maximum is reached.

Step 6. Band C RF and Mixer Alignment

- Perform step 6 as shown in the alignment chart. Remember to "rock" the generator dial as in step 4.

Step 7. Band D Oscillator Alignment

- Set receiver and generator at the exact frequency shown in the chart and make the indicated adjustments. Check for an image by setting the receiver at 30 mc, signal generator at 30.91 mc. If a signal is heard, correct by setting signal generator at 30 mc and turning C-16D clockwise until a new maximum is reached.

Step 8. Band D RF and Mixer Alignment

- Perform step 8 as shown in the alignment chart. Remember to "rock" the dial to find the desired generator setting.

HIGH-FREQUENCY OSCILLATOR, RF AND MIXER STAGES ALIGNMENT

STEP	BAND-SWITCH	RECEIVER AND SIGNAL GENERATOR	ADJUST FOR MAXIMUM*
1. (Oscillator)	A	1.65 mc	C-16A
		.55 mc	L-1
REPEAT STEP 1			
2. (Mixer and RF)	A	1.4 mc	C-12A then C-3
		.6 mc	L-9 then L-5
REPEAT STEP 2			
3. (Oscillator)	B	4.6 mc	C-16B
		Check for image	
		1.6 mc	L-2
REPEAT STEP 3			
4. (Mixer and RF)	B	3.9 mc	C-12B then C-3
		1.75 mc	L-10 then L-6
REPEAT STEP 4			
5. (Oscillator)	C	12.4 mc	C-16C
		Check for image	
		4.4 mc	L-3
REPEAT STEP 5			
6. (Mixer and RF)	C	10.4 mc	C-12C then C-3
		4.7 mc	L-11 then L-7
REPEAT STEP 6			
7. (Oscillator)	D	30.0 mc	C-16D
		Check for image	
		12.0 mc	L-4
REPEAT STEP 7			
8. (Mixer and RF)	D	27.0 mc	C-12D then C-3
		13.0 mc	L-12 then L-8
REPEAT STEP 8			

*If you have disturbed the pre-aligned setting of the slug of any of the coils, L-1 through L-12, proceed as follows:

Turn the slug counterclockwise until it is level with the top of the coil. Now turn the slug clockwise until you reach a maximum (1st maximum). Turning the slug still further clockwise you will reach another maximum (2nd maximum).

Coils L-1, L-2, L-3, L-6, L-9, L-10, and L-12 should be aligned on their first maximum, while coils L-4, L-5, L-7, L-8, and L-11 should be aligned on their second maximum.

It may help to know the original positions of the slugs in the pre-aligned coils. Approximate depths, measured from the top of the slugs to the top of the coil forms are: 3/16" (L-1, L-6); 7/16" (L-3, L-7); 1/4" (L-2); 5/8" (L-4, L-8); 5/16" (L-5, L-9, L-10, L-12); 3/4" (L-11).

DO NOT INTERCHANGE THE SLUGS OF ANY COIL.

BFO ALIGNMENT

Use the same setup as for RF and Mixer alignment, except control settings that are changed in the following steps.

- Turn the A-B-BAND-C-D switch to "C" position. Set the receiver dial near 6 mc, selecting a point at which no station is heard. Set the generator for 6 mc modulated output and tune the generator for a maximum meter reading at the receiver.
 - Turn the modulation off at the generator. Turn the BFO-MVC-AVC-ANL switch to BFO position.
 - Set the BFO control in a midway position (white dot pointing to the middle reference line).
 - Adjust the BFO coil, L-15, for zero beat using the IF alignment tool supplied.
- You will be approaching zero beat when you hear a change in tone, going from a high to low pitch. Continue adjusting the coil, until you reach a zero point of no sound.
- Now turn the BFO control to either side of the center setting. The tone should vary in pitch, from low to high, on either side of center setting. BFO alignment is now complete.

Q-MULTIPLIER ALIGNMENT

- Same as for BFO alignment, except control settings:

BFO-MVC-AVC-ANL	AVC position
A-B-BAND-C-D	A position
QX SELECTIVITY	Midway position
QX TUNE	Midway position (red pointer straight up)
- Set the MAIN TUNING dial near 1000 kc, selecting a point at which no station is heard. Set the generator for 1000 kc modulated output and tune the generator for a maximum meter reading at the receiver.
- Turn the PEAK-OFF-NULL switch to PEAK position. Now adjust L-14, the Q-Multiplier coil for maximum meter reading at the receiver. The PEAK circuit of the Q-Multiplier is now aligned.
- Switch the modulation off at the signal generator.
- Adjust R-25, the QX Null control, to half-way position.
- Turn the PEAK-OFF-NULL switch to NULL position. Note: The meter reading at the receiver will decrease.
- Slightly "rock" the QX TUNE control, to the right and then to the left of center setting, until you get the greatest meter "dip" at the receiver. Increase signal generator output during this procedure, to maintain a useable meter reading at the receiver.
- Turn R-25 very slowly counterclockwise, increasing the dip, until the lowest meter reading is reached.
- Repeat the last two steps until the greatest possible dip at the receiver meter has been achieved. The NULL circuit of the Q-Multiplier is now aligned.
- Install the receiver in the cabinet. Use six 6-32 x 5/16" screws.

ALIGNMENT ON THE AIR

The following alignment procedure can be used if a signal generator and meter are not available.

IF ALIGNMENT

Set the receiver controls for standard broadcast reception: OFF-STBY-RCV-CAL in RCV; BFO-MVC-AVC-ANL in AVC; AF and RF GAIN, fully clockwise; A-B-BAND-C-D in A; PEAK-OFF-NULL in OFF. Tune in a strong station near 1.6 mc on the MAIN TUNING dial.

Now use the IF alignment tool supplied to adjust the IF transformers for loudest signal. Start with Z-3 (top and bottom). Then adjust Z-2 (top and bottom) and Z-1 (top and bottom). Repeat in the same order until no further increase in signal is heard. During this procedure, reduce the AF GAIN setting whenever necessary.

HIGH-FREQUENCY OSCILLATOR, MIXER AND RF ALIGNMENT

Use the same control positions as for IF alignment, except: **TURN THE BANDSPREAD CAPACITOR FULLY CLOCKWISE. THIS IS ESSENTIAL FOR CORRECT CALIBRATION.**

Refer to the table given under instrument alignment of these stages for each band. The same adjustments can be made by ear, listening for maximum signal. The check for image frequencies can be made as described on page 28, except the image will be found by turning the receiver dial 910 kc from the setting to be checked. On bands B and C the image will come in 910 kc below the fundamental; on band D 910 kc above the fundamental.

NOTE: The order given must be followed exactly, with the capacitor adjustment made at the *beginning* of each step, and the coil adjustment at the end of each step. Usually only slight coil adjustments are needed.

Select stations as close as possible to those frequencies listed in the table. Actual stations will be used, instead of a signal generator, to supply the alignment signals. In each case use a station of known frequency only, preferably a station whose frequency is marked on the dial. Set the dial exactly at the station frequency actually used, not at the frequencies listed in the table.

After the adjustments specified in the table are completed, test your calibration by tuning in WWV on Band C at 5 and 10 mc, and on Band D at 15 and 20 mc.

BFO ALIGNMENT

Start with the same control settings as for RF alignment. Turn your receiver to the strongest signal available from WWV. Reduce the RF gain to a comfortable level. Set the BFO control in a midway position (white dot pointing to the middle reference line). Turn BFO-MVC-AVC-ANL to BFO.

Adjust the BFO coil, L-15, for zero beat, using the IF alignment tool supplied. Now turn the BFO control to either side of the center setting. The tone should vary in pitch, from low to high, on either side of center setting.

Q-MULTIPLIER ALIGNMENT

Tune your receiver to the strongest available signal from WWV. Set the QX TUNE control in the halfway position and the QX SELECTIVITY turned about $\frac{2}{3}$ of the way to the right. Switch PEAK-OFF-NULL to PEAK. There will be an apparent loss of gain because of the increased selectivity. Adjust L-14 until there is a noticeable change of pitch, with high notes decreasing, until a low, flat sound is heard. If you go past the required point, the tone will again become higher in pitch. This procedure is somewhat similar to zero-beating.

You are now ready to align the NULL circuit. Set R-25, the QX NULL control at the half-way position. Turn the PEAK-OFF-NULL switch to NULL. There will be a noticeable decrease in signal. "Rock" the QX TUNE control slightly until the signal reaches its faintest point. Now adjust R-25 very slowly, counterclockwise, until the greatest nulling effect has been achieved. Repeat these adjustments until no further nulling effect takes place.

Install the receiver in the cabinet. Use six 6-32 x 5/16" screws.

INSTALLING AN ANTENNA

A good antenna will enable you to obtain maximum performance from your receiver. On the rear of the chassis, two antenna inputs are provided, one for coaxial lead-in wire, the other for open-wire lead-in. A half-wave dipole is recommended for top performance on a particular band of frequencies, such as an Amateur band. An Amateur transmitting antenna is ideal for this purpose. A single wire antenna of between 30 to 50 feet provides the best all-around reception for short-wave listening.

If you prefer to use a single-wire antenna, see Figure 25 for suggested installation. For the exact specifications for a half-wave dipole antenna, see the antenna section in the "Amateur Handbook", published by the ARRL.

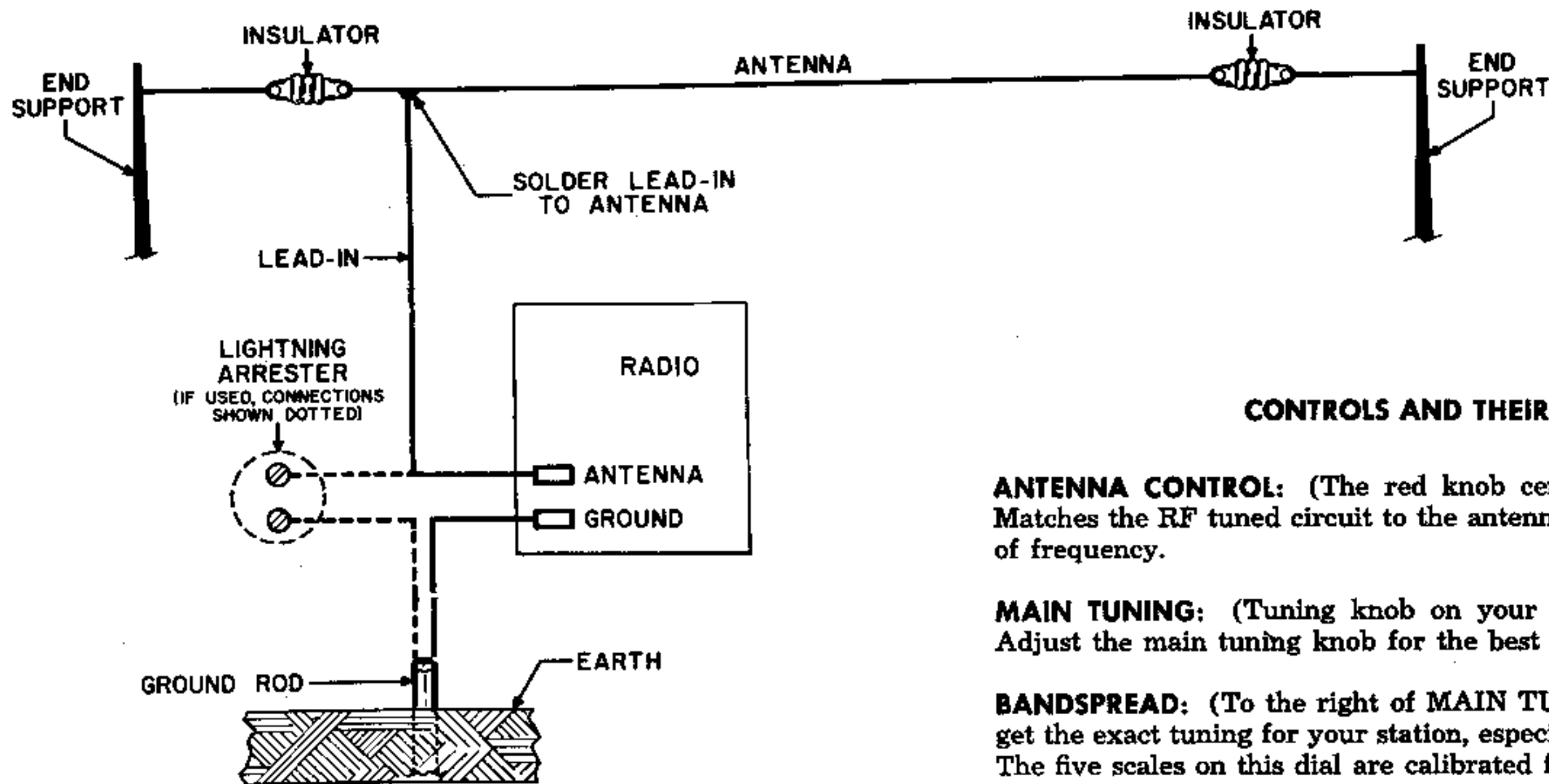

FIGURE 25. INSTALLING AN ANTENNA

OPERATING INSTRUCTIONS

You will gain the greatest pleasure from your receiver if you understand the full possibilities of this fine instrument. Those familiar with communications equipment will quickly recognize the added range and selectivity provided by this highly sensitive receiver. However, even the experienced operator will profit from a careful reading of the section on the use of the Q-Multiplier, since considerable skill and experience are required to fully realize the extra refinements afforded by these circuits.

For the new short wave listener, we suggest that these instructions be followed closely. The extra care used in tuning will be well rewarded by bringing in many distant (DX) stations. The section on the best time for shortwave listening will also be very helpful.

CONTROLS AND THEIR FUNCTIONS

ANTENNA CONTROL: (The red knob centered above the tuning dials). Matches the RF tuned circuit to the antenna, when there is a major change of frequency.

MAIN TUNING: (Tuning knob on your left, as you face the receiver). Adjust the main tuning knob for the best dial setting for your station.

BANDSPREAD: (To the right of MAIN TUNING) For fine tuning. Use to get the exact tuning for your station, especially for weak or distant stations. The five scales on this dial are calibrated for Amateur bands 80-10 meters.

CAUTION: MUST BE TURNED FULLY CLOCKWISE WHEN USING THE MAIN TUNING DIAL. OTHERWISE MAIN DIAL CALIBRATIONS WILL BE INACCURATE.

OFF-STBY-RCV-CAL: Turns the receiver on and off. Always in the RCV (Receive) position for listening. Should always be turned to OFF when you are through using the receiver. STBY (Standby) position silences the receiver, but keeps the tubes warm, ready for instant use. CAL (Calibration) position is used only with an accessory crystal calibrator, to check dial calibrations.

QX SELECTIVITY: Sharpens the selectivity of the receiver. Use only as described in Q-Multiplier operating instructions.

PEAK-OFF-NULL: Switches the Q-Multiplier circuits to PEAK (accentuate) or NULL (cancel out). In OFF position QX SELECTIVITY and QX TUNE are switched out of the circuit.

BFO-MVC-AVC-ANL: Selects the mode of operation of the receiver. BFO position is for CW (code and single sideband reception) only. MVC, AVC and ANL are for voice or music listening. AVC (automatic volume control) is the normal position.

MVC (manual volume control) switches out the AVC circuit. Experienced operators will use this position when necessary. ANL (automatic noise limiter) is used only for unusually noisy conditions.

RF GAIN: Controls sensitivity by adjusting the gain (amplification) of the RF and first IF stage of the receiver.

A-B-BAND-C-D: Bandswitch selects the desired listening band. Covers:

BAND A	.54— 1.65 mc
BAND B	1.6 — 4.6 mc
BAND C	4.4 —12.4 mc
BAND D	12.0 —30.0 mc

QX TUNE: Use for tuning the Q-Multiplier circuits. See section on Q-Multiplier operation.

BFO: Adjusts the BFO frequency to produce the desired audio tone for code reception. It is also used for single sideband (SSB) reception.

AF GAIN: This is the volume control. Adjust for desired loudness.

S-METER: If you already have the S-Meter kit, you have a valuable tuning aid. Wherever the operating instructions describe tuning procedure, tune for maximum meter deflection. The S-Meter is calibrated to show accurate signal strength readings when the BFO-MVC-AVC-ANL switch is in the AVC position.

CONTROL SETTINGS FOR STANDARD BROADCAST RECEPTION

OFF-STBY-RCV-CAL	RCV
BFO-MVC-AVC-ANL	AVC
RF GAIN	Fully Clockwise
A-B-BAND-C-D	A
PEAK-OFF-NULL	OFF
MAIN TUNING	Turn dial to desired station. (Bandspread dial must be turned all the way to the right.)

BANDSPREAD: Not needed for local stations. Use for fine tuning for DX (distant) reception.

ANTENNA CONTROL: Adjust red knob for strongest signal.

AF GAIN: Adjust for desired volume.

CONTROL SETTINGS FOR SHORT WAVE LISTENING

Set controls same as for standard broadcasts above, except:

PHONE RECEPTION

A-B-BAND-C-D: Switch to B, C or D depending on frequency of station wanted.

MAIN TUNING: Turn dial to desired station. For Amateur phone reception, set the MAIN TUNING dial at the index mark for the desired Amateur band. Notice the index marks that are identified on Figure 26. The BANDSPREAD calibrations for the Amateur bands are accurate only when the MAIN TUNING dial is set to the mark for the band in use.

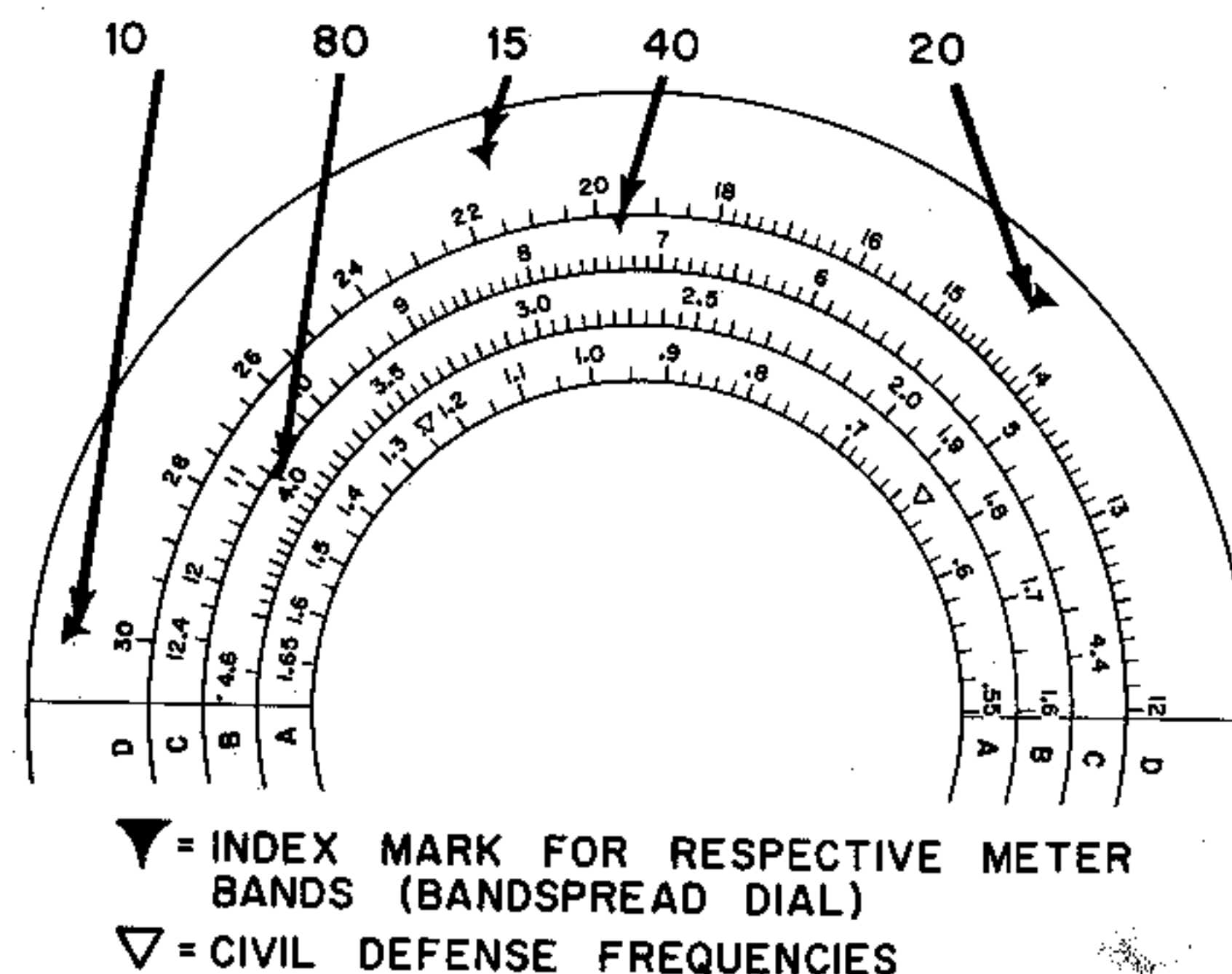

FIGURE 26. AMATEUR BAND INDEX MARKS (MAIN TUNING DIAL)

BANDSPREAD: After station is tuned in on MAIN TUNING dial, adjust BANDSPREAD knob for fine tuning. The BANDSPREAD control can be used in either of two ways. It can be left in a midway position while using the MAIN TUNING and then "rocked" a few degrees to the left or to the right for the best reception. Another method is to have it turned all the way to the right while the MAIN TUNING dial is set at the index mark for the desired Amateur band, or the high frequency end of any desired group of stations. Then the BANDSPREAD control can be slowly turned

to the left, sweeping through the group of stations until the desired station is heard clearly.

BFO-MVC-AVC-ANL: Usually in AVC position. May be switched to ANL during unusually noisy conditions, especially at the higher frequencies where automobile ignition and other man-made noises may interfere.

CW (CODE) RECEPTION

BFO-MVC-AVC-ANL
RF GAIN
A-B-BAND-C-D
AF GAIN

BFO
Use as volume control
Set for desired band
Set to maximum clockwise position

AMATEUR FREQUENCIES

BAND SETTING	AMATEUR BAND	FREQUENCY RANGE
B	80 meters	3.5 — 4.0 mc
C	40 meters	7.0 — 7.3 mc
D	20 meters	14.0 — 14.35 mc
D	15 meters	21.0 — 21.45 mc
D	10 meters	28.0 — 29.7 mc

MAIN TUNING: Set the MAIN TUNING dial at the index mark for the desired Amateur band.

BANDSPREAD: Slowly turn the BANDSPREAD dial until the desired station is heard.

BFO: Adjust the BFO control for the most pleasing note.

SINGLE SIDEBAND RECEPTION

OFF-STBY-RCV-CAL: RCV

BFO-MVC-AVC-ANL: MVC

MAIN TUNING: To index mark for desired Amateur band.

BANDSPREAD: Precedence has established the use of SSB transmitters in certain sections of each Amateur band. At the present time, these are:

80 meter band	high frequency end
40 meter band	high & low freq. ends
20 meter band	high frequency end
15 meter band	high frequency end
10 meter band	around 28.65 mc

RF GAIN: AT MINIMUM

AF GAIN: AT MAXIMUM

A standard AM transmitted signal consists of an RF carrier and two sidebands, which results from the modulation of the RF carrier. A SSB signal is characterized by the suppression of the carrier and one of the side bands. Thus the transmitted signal consists of one sideband only. It is fast becoming an increasingly popular method of transmission because it occupies less space in the radio spectrum and because there is considerably less interference encountered among SSB signals during reception.

Reception of SSB signals requires the reinsertion of a carrier before the signal can be demodulated. This is done by the BFO.

Start by tuning to the portion of an Amateur band containing SSB signals. While tuning, turn the RF GAIN control up until loud, but unintelligible sounds are heard. It will sound something like duck quacking. Switch the BFO-MVC-AVC-ANL control to BFO and carefully tune the BFO control until intelligible sound is heard. The BFO control may be left at its setting while the BANDSPREAD dial is tuned to other stations. However, a change in sideband transmission from "lower" to "upper" sideband or vice-versa requires a readjustment of the BFO control.

THE Q-MULTIPLIER

The purpose of the Q-Multiplier and its associated controls (QX SELECTIVITY and QX TUNE) is to improve the selectivity of the receiver. Selectivity is the ability to select only the desired station, separating it from adjacent stations which may be very close in frequency. For domestic and foreign broadcasts, it is recommended that the Q-Multiplier (PEAK-OFF-NULL) be in the OFF position, to maintain full audio quality. However, the Q-Multiplier can be used if you are trying for DX reception and are not concerned with audio quality.

The Q-Multiplier can be used either to peak (accentuate) a narrow band of desired frequencies, or to null (cancel) a narrow band of undesired frequencies. Experience with these controls will soon teach you the best settings for the existing conditions.

PEAKING.

First, tune in the signal to maximum loudness with the Q-Multiplier in OFF position. Then switch to PEAK position. There will be an apparent decrease of audio output, because the increased selectivity will narrow the IF band width. The gain will come up in the following peaking procedure.

Start with the QX SELECTIVITY control in the midway position. Now turn the QX SELECTIVITY control slowly to the right. At the same time "rock" the QX TUNING control back and forth, to either side of the midway position. During this procedure, you will find a point in the swing of the QX TUNING control where the signal is noticeably stronger. This is the desired QX TUNING control position. The QX SELECTIVITY control may be turned further to the right for greater peaking. However, if it is turned up too far, oscillation may result. The best operating point will be found below the point of oscillation.

NULLING.

Tune in the desired signal while the Q-Multiplier is OFF. If the interfering signal is within 3500 cycles of the desired signal, it can be nulled by the Q-Multiplier.

Turn the PEAK-OFF-NULL switch to NULL. Adjust the QX TUNING control slowly, from the far left to the far right position, until the undesired signal is nulled out. Note that there are two positions in which one of the signals is nulled. In one, the undesired signal is nulled. In the other, it is the desired signal which is removed. If the desired signal is nulled, the audio will be highly distorted. In this case, it is simple to readjust the QX TUNING for the desired nulling results.

NOTE: Do not use the MAIN TUNING and BANDSPREAD controls while adjusting the Q-Multiplier controls.

REMOTE CONTROL

The two terminals marked REMOTE at the rear of the chassis can be connected to the transmit-receive switch of a transmitter, or to the contacts of a transmit-receive relay. When you use remote control, the OFF-STBY-RCV-CAL switch should be set in the STBY position.

INSTALLING THE S-METER

An easily installed S-METER is available as an accessory to the receiver. The S-METER makes it possible to measure the relative strength of incoming signals. It is calibrated in nine "S" steps of approximately 6 db each, so that each step is double the signal strength of the preceding step. The last six calibrations read plus 10, 20, 30, 40, 50, and 60 db over S9.

If you have not already purchased the S-METER, save this manual. It includes instructions for assembling the S-METER. This meter is to be installed on the front panel.

SEE FIGURE 27.

DO NOT ADD THIS CIRCUIT WHILE THE RECEIVER IS PLUGGED INTO A POWER OUTLET.

- Remove the receiver from the cabinet. Remove the bottom plate. Remove the S-METER hole cover from the front panel.
- Prepare the S-METER for mounting as follows: (Do not lose the solder lugs, lockwashers, and two sizes of nuts packed with the meter.) Remove the shorting wire between the two terminals. Put a solder lug over each terminal, position them as shown, and fasten each with a nut.
- Position the S-METER with the scale toward you.
- There is a strip of tape on the back of the S-METER window. Without lifting the tape from the window back, remove the protective covering from the tape so the unused adhesive side is exposed.
- Line up the window cut-out and the hole for the zero-adjust screw with the meter scale and the zero-adjust screw of the meter.
- Press the S-METER window firmly against the face of the meter, maintaining the line up.
- Mount the S-METER and window assembly on the S-METER bracket using the four lockwashers and nuts supplied.
- Solder one end of a violet wire to the plus (+) terminal.
- Solder one end of a white-brown wire to the other or unmarked terminal.
- Cut a length of tape long enough to run along the bottom edge of the meter window, allowing a $\frac{3}{8}$ " overlap on both sides. Press the upper edge of the tape along the bottom edge of the window, leaving half the width free for later mounting.
- Mount the meter bracket on top of the chassis. Use two 6-32 x 5/16" screws. Do not tighten them. Pass both the violet and the white-brown wires through hole B.

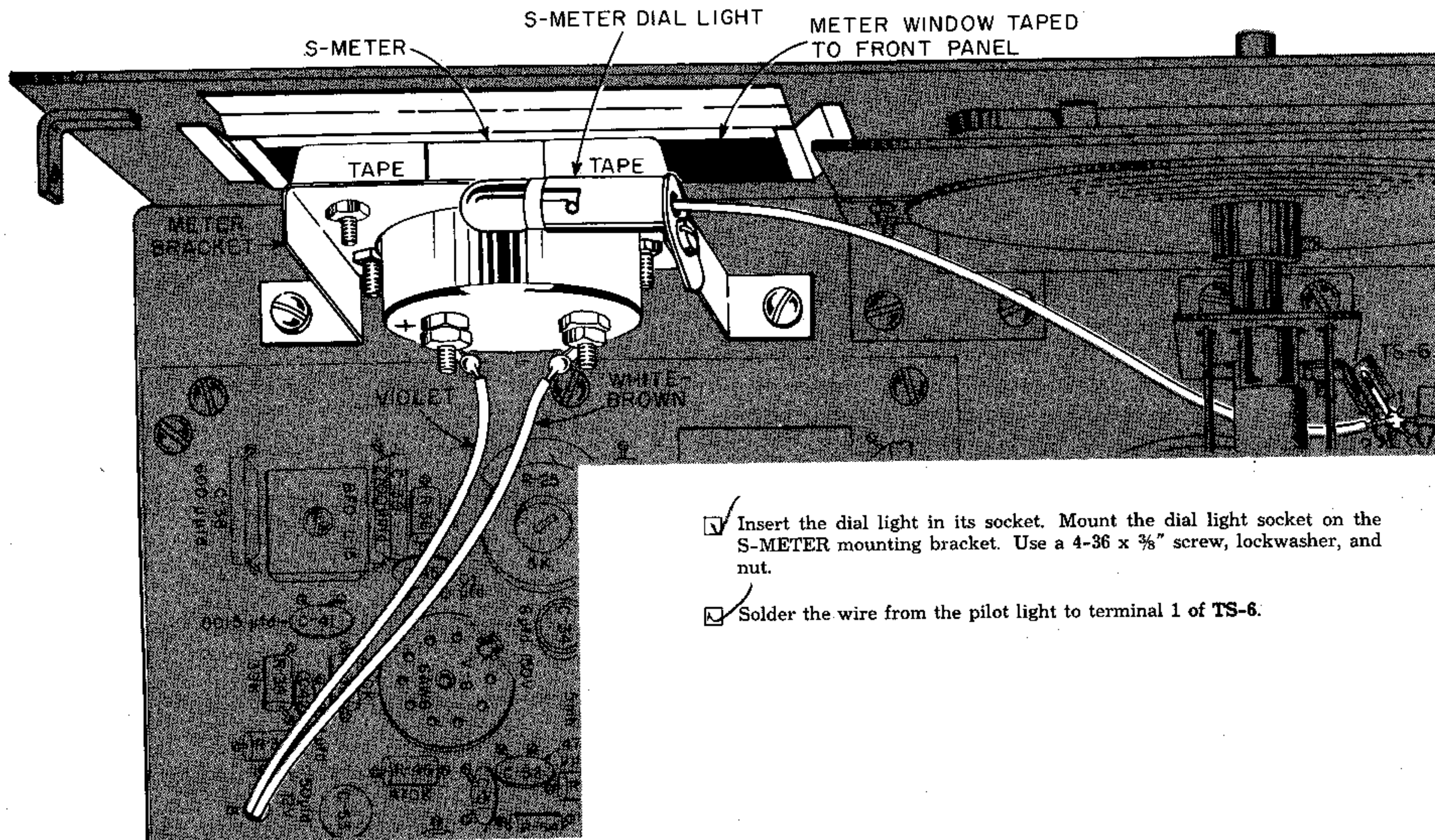

FIGURE 27. INSTALLING THE S-METER

- Insert the dial light in its socket. Mount the dial light socket on the S-METER mounting bracket. Use a 4-36 x $\frac{3}{8}$ " screw, lockwasher, and nut.
- Solder the wire from the pilot light to terminal 1 of TS-6.

- Push the meter assembly forward until the meter window is positioned against the front panel. Tighten the mounting screws.
- Secure the meter window in place by taping across the top and down both sides. Press down the tape already on the bottom edge.

SEE FIGURE 28.

- Mount the 680Ω S-METER adjust control as shown.
- Carefully unsolder the leads of R-30, a 680Ω resistor (blue, gray, brown) from the IF printed circuit board. Throw it away.
- Solder the free end of the violet wire in hole 21.
- Connect, but do not solder, the free end of the white-brown wire to terminal 3 of TS-5.
- Solder one end of an orange wire to terminal 3 of the 680Ω control. Solder the other end in hole 37.
- Solder one end of a red wire to terminal 1 of the 680Ω control. Solder the other end to terminal 1 of TS-4.

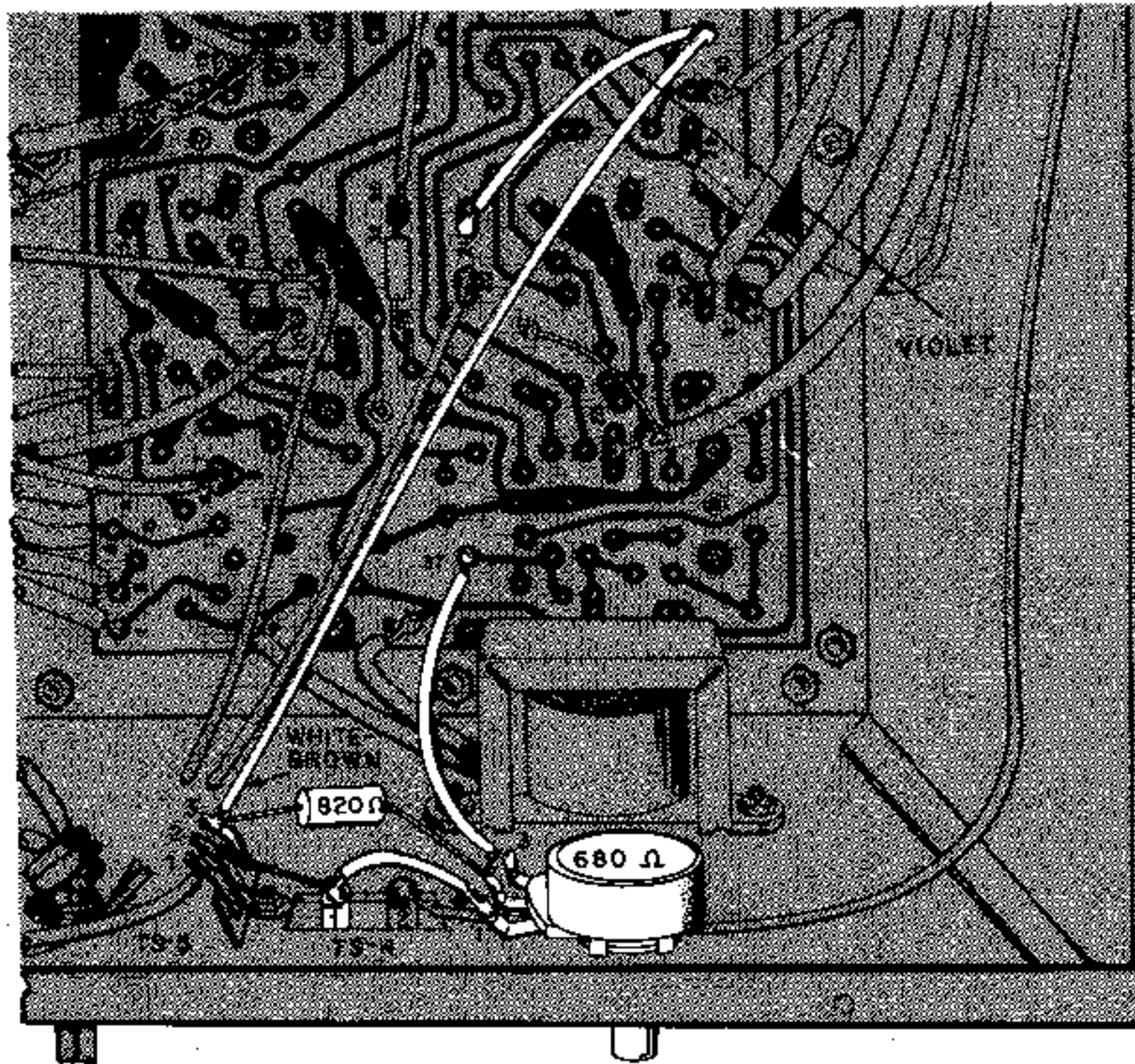

FIGURE 28. S-METER WIRING

- Solder one lead of a 820Ω resistor (gray, red, brown) to terminal 3 of TS-5. Solder the other lead to terminal 2 of the 680Ω control.

ADJUSTMENT OF THE S-METER

- Adjust the screw (zero set) at the bottom of the S-METER until the meter pointer is at zero (extreme left end of calibration).
- Connect the receiver to a power outlet. Turn the OFF-STBY-RCV-CAL switch to STBY position, and allow the receiver to warm up. Turn the BFO-MVC-AVC-ANL switch to AVC.
- Adjust the 680Ω control so the meter reads zero.
- Turn the receiver off, and remove the plug from the power outlet. Replace the bottom plate, and reinstall the receiver in the cabinet.

The receiver is now ready to operate.

INSTALLING THE CRYSTAL CALIBRATOR

NOTE: Do not add this unit while the receiver is plugged into a power outlet.

- Remove the chassis from the cabinet. Remove the bottom plate.
- Mount the Crystal Calibrator inside the chassis using two 4-36 x 3/8" screws, lockwashers, and nuts. (See the photograph on page 40.)

There are four wires coming from the Crystal Calibrator. Connect these wires as follows. It is important that they be cut to the proper length to eliminate unnecessary slack.

- Solder the red wire to terminal 1 of TS-5.
- Solder the green wire to terminal 1 of TS-1.
- Solder the black wire to hole 7 on the IF printed circuit board.
- Solder the brown wire to hole 5 on the IF printed circuit board.

- Leave the Crystal Calibrator switch in the ON position to control the Calibrator from the front panel of the receiver
- Remount the bottom plate and reinstall the receiver in the cabinet.

You are now ready to use the Crystal Calibrator with your receiver. Simply turn the OFF-STBY-RCV-CAL switch to CAL and calibrate your receiver as explained in the Crystal Calibrator manual.

INFORMATION FOR SHORT WAVE LISTENERS

WHEN TO LISTEN

Under normal atmospheric conditions, with patience and practice, it's possible to hear stations from all over the world in a single evening—at times even within a few minutes. All you need is your receiver, a good antenna, a knowledge of *where* and *when* to listen—plus persistence.

Short-wave radio transmitters include land communications stations, maritime stations, aeronautical stations, Amateur (Ham) stations, and broadcasting stations. Of these, the broadcasting and Amateur (Ham) stations are of most interest to the short-wave listener (SWL). However, there are many other "specialties" to listen to such as international radio telegraph or telephone point-to-point communications; shipping and coastal radio; plane and ground communications; weather station reports and time signals; special expeditions, and other unusual events.

By international agreement, each type of station is assigned certain bands for operations.

You'll find that the short-wave portions of the dial on your receiver are calibrated in megacycles. A megacycle is 1000 kilocycles (kc).

Short-wave stations operate in these megacycle bands—5.95 to 6.20 mc; 7.0 to 7.3 mc amateur band; 9.5 to 9.8 mc; 11.7 to 12.0 mc; 14.0 to 14.3 mc amateur band; 15.10 to 15.45 mc; 17.5 to 17.7 mc and 28.0 to 29.7 mc amateur band. Sometimes these bands are given in terms of meters (m)—such as the 49, 41, 50, 31, 25, 20, and 19 meter bands. Thus, *megacycles* refer to *frequency*; *meters* refer to *wavelength*.

Reception conditions on each of the short-wave broadcast bands vary a lot at different times of the day and night, and also at different seasons of the year. Experience will teach you when to listen on each band.

In general, for SWL's in North America, the best reception on each of these bands during the fall and spring months should be:

The 6 mc band—evening for Latin America and Europe.

The 7 mc bands—late afternoon and evening for Europe; evening and early morning for Amateur stations.

The 9 mc band—morning (6 to 8 a.m. your local time) for Asia and Australia; afternoon for Europe and Africa; evening for Europe and Latin America.

The 11 mc band—morning (6 to 9 a.m. your local time) for Asia and Australia; afternoon for Europe and Africa; evening for Latin America.

The 14 mc band—late morning and afternoon for Amateur stations.

The 15 mc band—morning and afternoon for Europe and North America; evening for North and South America.

The 29 mc band—daylight hours for Amateur stations.

During the winter months, the best bands for evening reception are lower than during the fall and spring. For instance, the 9 mc band becomes poor for reception from Europe during the evening hours, and the 6 mc band becomes the best band for European reception. However, the 29 mc Amateur band is best during winter months, especially at the peak of the sunspot cycle.

In the summer months, the best evening reception shifts to the higher bands. Evening reception from Europe becomes good in the 11 mc band, although the 9 mc band remains good for reception from that area.

Year-around DX (Distant reception) bands are the 9 mc and 11 mc bands, although consideration there must be given to receiving different parts of the world best in summer or winter.

The expected reception just outlined is for normal conditions. The factors which affect long-distance radio transmissions vary from day to day. On some days, for instance, reception will be quite good, but at times, generally for periods of several consecutive days, transmission conditions will be "disturbed" and only the more powerful stations can be heard.

But don't get discouraged because normal conditions will return after the disturbance has ended, and reception will again be good.

Here's a special caution: Short-wave broadcasting stations often change their schedules and/or frequencies with little or no prior notice. Always be on the alert for announcements of such changes.

HOW IT WORKS

An antenna input is provided for either open wire line or for coaxial cable.

The signal is fed from the antenna to the grid of the RF amplifier, V-1, the 6BZ6, through the tuned circuit of the last section (wafer E-F) of the band-switched coils and C-1A. The signal goes to the mixer (the pentode section of V-2, the 6BH8, through the tuned circuit of the band-switched (wafer C-D) coils and C-1B with the BANDSPREAD capacitor, C-2A. The first section of S-1 (wafer A-B) switches coils in the oscillator grid (the triode section of the 6BH8), which operates as a tuned grid oscillator. The oscillator is tuned by C-1C and by C-2B, the BANDSPREAD capacitor. This oscillator operates continuously even when the receiver is in standby position, and the plate of this tube is supplied with regulated voltage through V-3, the OB2. This insures maximum oscillator stability. The oscillator voltage injection takes place through a 10 $\mu\mu\text{fd}$ capacitor on band A, through a 3.3 $\mu\mu\text{fd}$ capacitor on band B, and through the internal capacity between the two sections of the 6BH8 on the two high bands, C and D.

The Q-Multiplier circuit is inserted at the output of the mixer. This is a tuneable null or peak circuit which either puts a sharp peak in the IF response curve, or a shiftable null which can be adjusted to provide as much as 60 db attenuation. This circuit makes it possible to tune out much of the unwanted interference and to bring in the wanted signal more clearly. This is accomplished with V-4 (the 12AX7), L-14, C-26, and the associated circuitry.

The IF amplifier section consists of the pentode sections of V-5 and V-6, both 6AZ8 tubes. These IF amplifiers are stabilized.

The detection takes place in the first of three diodes of the 6BC7, V-7. The second diode is used as a delayed AVC rectifier which can be turned off by S-3 at the front panel. A two-volt signal must be applied from the second detector before AVC action begins. The third section of the 6BC7 is used as a series noise limiter which cuts off the high noise peaks. This circuit is inserted between the second detector and the volume control by the switch, S-3, on the front panel.

The audio voltage amplifier consists of the triode section of the 6AZ8 second IF amplifier, V-6B. The output power amplifier, the pentode section of the 6AW8A (V-8), can either drive low impedance phones or an 8 Ω speaker. The triode section of the 6AW8A is used as the beat frequency oscillator (BFO). The BFO output is injected into the grid of the second IF amplifier, V-6A, through the capacity coupling available in R-32, a 10meg Ω resistor. Injecting the BFO output into the second IF reduces the power necessary to get adequate BFO action, which permits this circuit to operate with a minimum of harmonics.

The 6X4 full-wave rectifier tube, V-9, provides the DC operating voltages.

When this receiver is on "STANDBY", the cathodes of the RF amplifier and the first IF amplifier are biased to cut-off. "Break-in" operation is made possible by connecting an external keying relay to the "remote" terminals at the rear of the receiver when it is switched to "Standby". Shorting these terminals restores the receiver to operation.

This receiver is designed so the 100 kc Crystal Calibrator may be installed internally and operated from the front panel, as shown elsewhere in this manual.

The S-METER may be installed on the front panel and wired into the circuit as shown elsewhere in this manual.

RESISTANCE CHART

Control positions: OFF-STBY-RCV-CAL in OFF; QX SELECTIVITY at maximum; PEAK-OFF-NUL in PEAK; BFO-MVC-AVC-ANL in AVC; RF GAIN at maximum; A-B-BAND-C-D in A; AF GAIN at maximum.

All readings from point indicated to chassis ground except: *Readings from point indicated to B+ (holes 11 and 12 on the IF printed circuit board.)

TUBE	PIN								
	1	2	3	4	5	6	7	8	9
V-1 6BZ6	3M	100K*	0	.1 Ω	2.3K*	56K*	0	NS	NS
V-2 6BH8	0	27K	15K*	0	.1 Ω	150 Ω	82K	10K	2.7K
V-3 OB2	NS	0	4.5K*	NS	NS	NS	NS	NS	NS
V-4 12AX7	240K*	2.7M	1.5K	0	0	28K*	2.7M	5.6K	.1 Ω
V-5 6AZ8	2.7K*	47K*	100K*	.1 Ω	0	2.1M	0	0	0
V-6 6AZ8	2.7K*	47K*	680 Ω	.1 Ω	0	2M	2.7K	220K*	1M
V-7 6BC7	100 Ω	1M	NS	0	1.2 Ω	230K	230K	440K	0
V-8 6AW8A	open	47K	260K	0	.1 Ω	180 Ω	500K	0*	175 Ω *
V-9 6X4	185 Ω	NS	.1 Ω	0	NS	185 Ω	300 Ω *	NS	NS

NS = not significant.

SERVICE HINTS

The proper operating voltages are found on the circuit diagram, Figure 29.
 The proper resistances are found in the resistance chart on page 38.
 Never measure resistances with the receiver turned on.

TROUBLE	POSSIBLE CAUSE	SERVICE PROCEDURE
Receiver dead	Defective tube(s)	Replace defective tubes.
	Tubes in wrong sockets or not seated	Visual inspection.
	Line cord not in AC outlet	
	Fuse open	Check fuse. Look for power supply shorts.
	Phone jack miswired	Check voltages and resistances. Check wiring for wrong connections.
	No B+ voltage	
	OFF-STBY-RCV-CAL switch open or miswired	
	R-1 open	
	R-2 open or miswired	
	Speaker (or headphones) defective	
S-4 miswired		
Oscillator not working	Check wafer A-B on BAND switch, and associated coils. Test 6BH8.	
Poor sensitivity on one band only	Terminals of Bandswitch or coils poorly soldered	See page 14. Resolder terminals.
Poor sensitivity on all bands	RF GAIN control turned too low	Check control setting.
	Low B+ voltages	Check C-54.
	Defective tubes	Check tubes, especially 6BZ6, 6BH8, 6AZ8, 6X4.
	IF stages misaligned	Realign. See page 27.
	RF and mixer stages misaligned	Realign. See page 29.
	Improper setting of Q-Multiplier controls	See page 29.
Output distorts on strong AM signals when receiver is in AVC position	AVC line is grounded	Check S-3 wiring, C-46, C-59 and C-60. Test 6BC7.
	Distortion on strong local stations	Turn down RF GAIN.

Receiver oscillates ("motorboats")	Tube shields not seated against ground clips	Reseat all shields.
	Bad ground on shielding of the lead from pin 9 of 6BH8	Check solder connections.
	IF circuits regenerative	Check C-30 and C-35.
	RF and mixer circuits regenerative	Nut loose on spade lug in hole K of RF printed circuit board. See Figure 23.
	RF shield plate not properly soldered to C-1	Check solder joint.
	QX SELECTIVITY control set too high	Readjust QX SELECTIVITY.
Hum	C-49 positioned wrong	Position correctly.
	Open filter capacitor	C-54 defective.
	Shorted tube	Test tubes.
	Short circuit which draws excessive current	Look for wrong connections and uninsulated wires shorting.
	Bad ground to the printed circuit boards	Check solder connections of yellow wire from hole 33 on IF board to ground.
Beat frequency oscillator does not function	Bad 6AW8A	Replace tube.
	S-3, L-15, C-38, or C-39 open, shorted, or miswired	Check voltages, resistance, and wiring.
	L-15 not properly adjusted	Readjust L-15.
Receiver High-Frequency oscillator unstable	Low B+ (OB2 not "firing")	OB2 should glow blue. Measure the voltages.
	Defective 6BH8	Replace 6BH8 tube.
Adjustment of C-12 or C-16 doesn't affect alignment	Trimmers miswired	Recheck C-12 or C-16 wiring.
	Terminals shorted or not soldered on wafers A, B, C or D of switch S-1.	Check soldering of S-1 terminals. Check for shorts on foil side of S-1.
Q-Multiplier not operating	Defective 12AX7	Replace 12AX7 tube.
Does not peak	L-14 improperly adjusted	Readjust L-14.
Does not null	R-25 improperly adjusted	Readjust R-25.

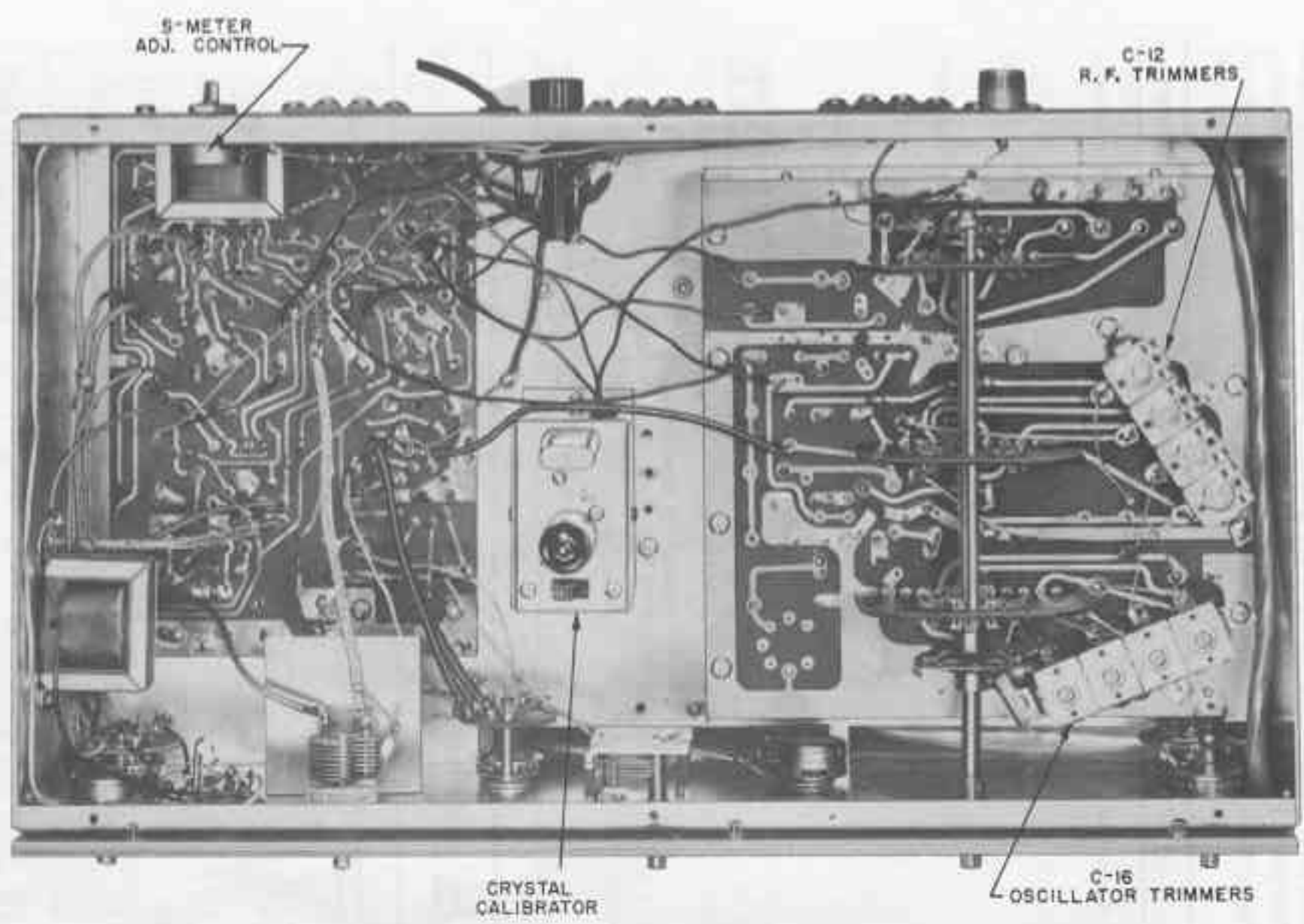
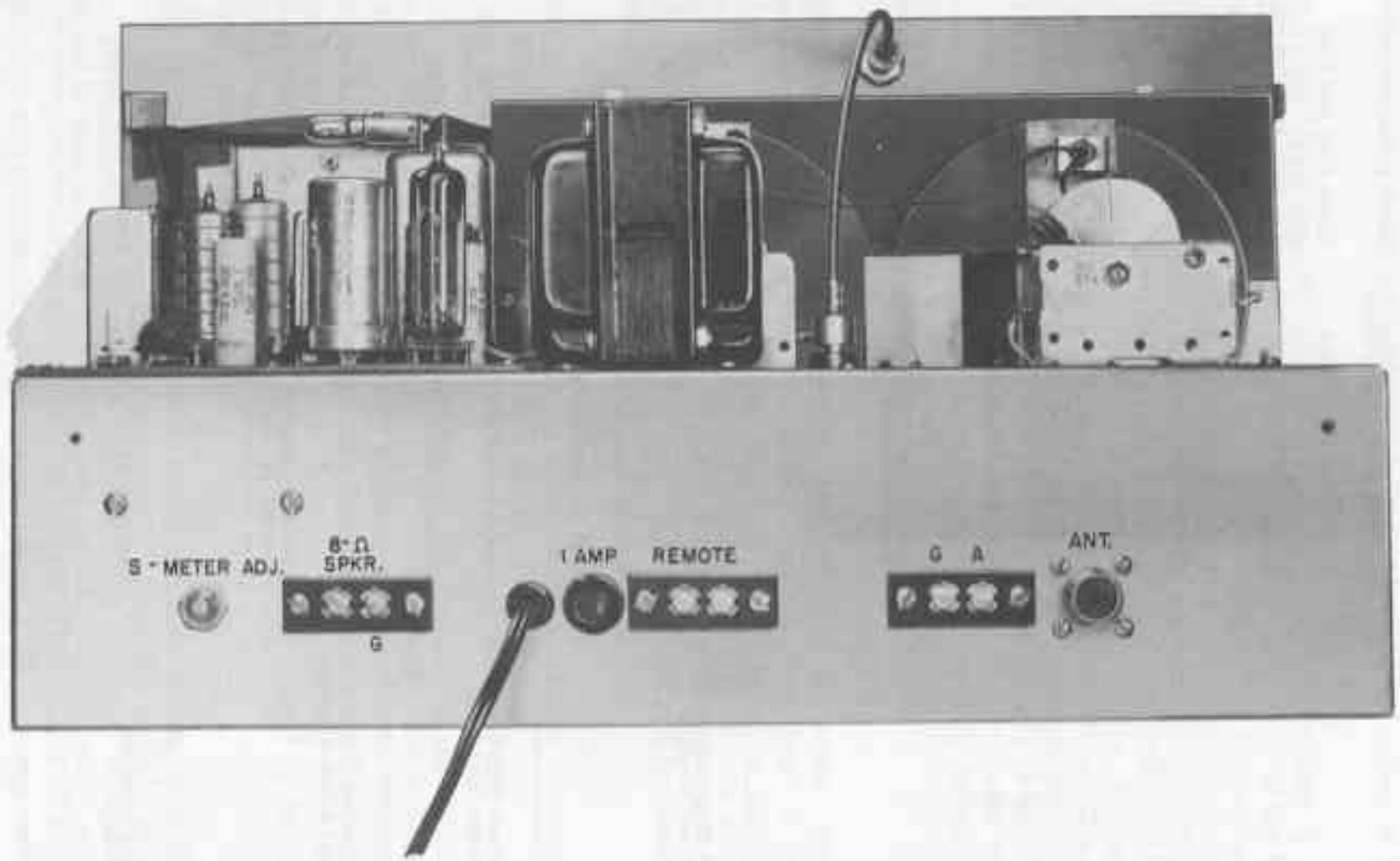

ALLIED SERVICE FACILITIES

If the kit does not operate properly, we recommend the following:

Please write our Kit Department giving stock number and date of purchase of the kit. Also, describe fully what appears to be wrong. We may be able to determine a wiring error or a defective part.

This wired KNIGHT-KIT may be returned for inspection within one year after purchase for a special service charge of \$15.00. Parts within the standard EIA 90-day warranty period will be replaced without charge for the parts. A charge will be made for parts damaged in construction or because of a wiring error, or for parts which are beyond the 90-day warranty period. After the one-year period, service charges are based on the length of time required to repair the unit, plus the cost of any parts required.

PLEASE NOTE: KITS WIRED WITH ACID CORE SOLDER OR PASTE FLUXES ARE NOT ELIGIBLE FOR REPAIR OR SERVICE AND WILL BE RETURNED TO YOU NOT REPAIRED, AT YOUR EXPENSE.

Allied's service facilities are primarily for inspection and trouble shooting. Kits not completely wired, which require extensive work, will be returned collect with a letter of explanation.

If you return this kit, pack it well. To prevent damage in shipment, use a large enough carton so that cushioning materials can be placed around the instrument. Do not use the original carton. Cushion it well and tightly.

Mark it: **FRAGILE—DELICATE ELECTRONIC EQUIPMENT.** Send the kit prepaid and insured. We will return the repaired kit to you C.O.D. as soon as repairs are completed. If you wish to save C.O.D. fees, your advance remittance may be enclosed for standard repair charges plus transportation costs. Any excess remittance will be refunded.

ALLIED'S GUARANTEE ON KNIGHT-KITS

The designs and components selected for KNIGHT-KITS represent over a quarter of a century of experience in kit development. Allied extends these firm guarantees on KNIGHT-KITS.

We guarantee that the circuits of all KNIGHT-KITS have been carefully engineered and tested.

We guarantee that only high-quality components are supplied. All parts are covered by the standard EIA 90-day warranty. Any faulty components will be replaced prepaid and without charge if reported to us within the warranty period. We reserve the right to request the return of defective parts.

If your kit was damaged in a parcel post shipment, please write us at once, describing the condition in which the shipment was received. If your kit was part of a Railway Express shipment that was damaged in transit, please notify the Railway Express agent at once and then write us.

PARTS LIST

CAPACITORS			Symbol No.	Description	Part No.	Symbol No.	Description	Part No.
Symbol No.	Description	Part No.	C-18	Ceramic tubular, 3.3 μ fd	276039	C-38	Mica, 600 μ fd	296018
C-1	Main tuning	282012	C-19	Ceramic disc, 10 μ fd	276018	C-39	Mica, 2700 μ fd	296017
C-2	Bandsread	282011	C-20	Ceramic disc, 560 μ fd	277568	C-40	BFO control, 50 μ fd variable	281011
C-3	Antenna control, 80 μ fd, variable	281016	C-21	Ceramic disc, .01 μ fd	276015	C-41	Ceramic disc, .0015 μ fd	276157
C-4	Molded tubular, .1 μ fd —200V	209001	C-22	Ceramic disc, .01 μ fd	276015	C-42	Ceramic disc, .01 μ fd	276015
C-5	Ceramic disc, .01 μ fd	276015	C-23	Ceramic disc, .0015 μ fd	276157	C-43	Ceramic disc, .02 μ fd	276025
C-6	Mica, 100 μ fd	296023	C-24	Ceramic disc, .01 μ fd	276015	C-44	Ceramic disc, 470 μ fd	276478
C-7	Ceramic disc, .01 μ fd	276015	C-25	Ceramic disc, .01 μ fd	276015	C-45	Ceramic disc, .01 μ fd	276015
C-8	Ceramic disc, .01 μ fd	276015	C-26	QX TUNE	282013	C-46	Ceramic disc, .0015 μ fd	276157
C-9	Ceramic disc, .01 μ fd	276015	C-27	Ceramic disc, 470 μ fd	276478	C-47	Ceramic disc, .0047 μ fd	276477
C-10	Mica, 200 μ fd, 3%	295001	C-28	Mica, 2700 μ fd	296017	C-48	Ceramic disc, 330 μ fd	276338
C-11	Ceramic disc, .01 μ fd	276015	C-29	Mica, 1000 μ fd	296002	C-49	Electrolytic tubular, 10 μ fd—25V	201100
C-12	3-30 μ fd compression trimmers, four on bracket	285002	C-30	Ceramic disc, .0015 μ fd	276157	C-50	Ceramic disc, 330 μ fd	276338
C-13	Mica, 680 μ fd	296019	C-31	Molded tubular, .1 μ fd —200V	209001	C-51	Ceramic disc, .0047 μ fd	276477
C-14	Mica, 2000 μ fd	296020	C-32	Ceramic disc, .01 μ fd	276015	C-52	Ceramic disc, 470 μ fd	276478
C-15	Mica, 5000 μ fd	296021	C-33	Ceramic disc, .01 μ fd	276015	C-53	Electrolytic tubular, stand-up type, 50 μ fd—12V	209002
C-16	3-30 μ fd compression trimmers, four on bracket	285002	C-34	Electrolytic, tubular, stand-up type 8 μ fd —150V	209000	C-54	Electrolytic, 20/20 μ fd—250V	234302
C-17	Ceramic disc, .0047 μ fd	276477	C-35	Ceramic disc, .002 μ fd	276026	C-55	Ceramic disc, .0047 μ fd	276477
			C-36	Molded tubular, .1 μ fd —200V	209001	C-56	Ceramic disc, .0047 μ fd	276477
			C-37	Ceramic disc, .01 μ fd	276015	C-57	Mica, 100 μ fd	296023

Symbol No.	Description	Part No.
C-58	Mica, 100 μ fd, odd shaped	296022
C-59	Ceramic disc, .01 μ fd	276015
C-60	Ceramic disc, 25 μ fd	296015
C-61	Ceramic disc, .01 μ fd	276015
C-62	Ceramic disc, .01 μ fd	276015
C-63	Mica, 33 μ fd	266339
C-64	Tubular ceramic, 50 μ fd \pm 2%	See L-8

COILS

L-1	Oscillator, Band A	122203
L-2	Oscillator, Band B	122204
L-3	Oscillator, Band C	122205
L-4	Oscillator, Band D	122206
L-5	RF, Band A	122207
L-6	RF, Band B	122208
L-7	RF, Band C	122209
L-8	RF, Band D, with C-64 capacitor	122210
L-9	Mixer, Band A	162005
L-10	Mixer, Band B	162006
L-11	Mixer, Band C	162007
L-12	Mixer, Band D	162008
L-13	RF choke, 5 millihenries	161001
L-14	Q-Multiplier	162010
L-15	BFO	162009
L-16	Filter choke, 5.5 henries	140003

CONNECTORS

J-1	Coaxial antenna jack	502222
J-2	Phone jack	502228

RESISTORS

All resistors $\frac{1}{2}$ w, 10%, unless specified otherwise

R-1	68 Ω	301680
R-2	RF GAIN control, 5K Ω	390115
R-3	100K Ω , 1 watt	304104
R-4	33 Ω	301330
R-5	27K Ω	301273
R-6	4700 Ω , 2 watt	307472
R-7	10K Ω , 1 watt	304103
R-8	47K Ω	301473
R-9	68 Ω	301680
R-10	6800 Ω	301682
R-11	2200 Ω	301222
R-12	33 Ω	301330
R-13	82K Ω	301823
R-14	150 Ω	301151
R-15	820K Ω	301824
R-16	220K Ω	301224
R-17	2.7 meg Ω	301275
R-18	1500 Ω	301152
R-19	2700 Ω	301272
R-20	100K Ω	301104
R-21	5600 Ω	301562
R-22	330 Ω	301331
R-23	2.7 meg Ω	301275
R-24	QX SELECTIVITY control, 10K Ω	390134
R-25	QX NULL control, 5K Ω	390133
R-26	47K Ω	301473
R-27	2700 Ω	301272
R-28	100K Ω	301104
R-29	27K Ω	301273
R-30	680 Ω	301681
R-31	47K Ω	301473
R-32	10 meg Ω	301106
R-33	2700 Ω	301272
R-34	1 meg Ω	301105
R-35	1 meg Ω	301105
R-36	47K Ω	301473
R-37	220K Ω	301224
R-38	39K Ω	301393
R-39	100K Ω	301104
R-40	220K Ω	301224
R-41	220K Ω	301224
R-42	1 meg Ω	301105
R-43	1 meg Ω	301105
R-44	AF GAIN control, 1 meg Ω	390009
R-45	2700 Ω	301272

Symbol No.	Description	Part No.
R-46	470K Ω	301474
R-47	82 Ω	301820
R-48	100 Ω	301101
R-49	220K Ω	301224
R-50	3.3 Ω	301338
R-51	33 Ω	301330
R-52	1 meg Ω	301105
R-53	10K Ω	301103
R-54	100K Ω	301104

SWITCHES

S-1	A-B-BAND-C-D	435004
S-2	PEAK-OFF-NULL	432129
S-3	BFO-MVC-AVC-ANL	432130
S-4	OFF-STBY-RCV-CAL	432131

TERMINAL STRIPS

TS-1	2-screw terminal	441201
TS-2	2-screw terminal	441201
TS-3	4-terminal	440401
TS-4	2-screw terminal	441201
TS-5	3-terminal	440301
TS-6	2-terminal	440202
TS-7	2-terminal	440201

BULBS

I-1	Dial Light #47	640002
I-2	Dial Light #47	640002

TRANSFORMERS

Z-1	Intermediate frequency	122211
Z-2	Intermediate frequency	122211
Z-3	Intermediate frequency	122211
T-1	Output	102200
T-2	Power	101311

FUSE

F-1	1 Ampere	491001
-----	----------	--------

TUBES

V-1	6BZ6	610050
V-2	6BH8	611023
V-3	OB2	610051
V-4	12AX7/ECC83	611012
V-5	6AZ8	611024
V-6	6AZ8	611024
V-7	6BC7	611025
V-8	6AW8A	611026
V-9	6X4	610023

MISCELLANEOUS

Description	Quantity	Part No.
Alignment tool, I.F.	1	957000
Alignment tool, R.F.	1	957003
Board, printed circuit, I.F.	1	820019
Board, printed circuit, R.F.	1	820020
Bushing, threaded, $\frac{3}{8}$ "	2	470075
Cabinet assembly	1	040040
Cabinet	1	700026
Edge trim strip	1	470122
Chassis	1	461330
Dial, crystal	1	870028
Dial, handsread tuning	1	870037
Dial, main tuning	1	870036
Dial, crystal bracket, left	1	470112
Dial, crystal bracket, right	1	470111
Drive bracket, vernier	2	470113
Foot, rubber	4	831001

Description	Quantity	Part No.
Front panel assembly	1	040041
Electrical tape, 5"	2	811007
Front panel	1	462223
S-Meter hole cover	1	870029
Large bezel	1	470123
Small bezel	1	470124
Grommet, small	3	830001
Grommet, large	1	830200
Holder, fuse, with hardware	1	492200
Knob, control	9	764204
Knob, tuning and bandsread	2	764532
Knob, antenna control	1	765000
Manual, instruction	1	750182
Plate, bottom	1	463303
Pointer, QX TUNE	1	470109
Shaft	2	470115
Shaft coupler	2	470114
Shaft, metal flexible	1	860012
Shield, BFO capacitor	1	470107
Shield bracket, RF chassis	1	470117
Shield, can, Q-multiplier	1	470121
Shield, tube, medium	1	510002
Shield, tube, short	4	510004
Shield, tube, long	2	510003
Socket, tube, 7-pin	2	501672
Socket, tube, with ground clip, 7-pin	1	501674
Socket, tube, with ground clip, 9-pin	6	501695
Socket, dial light	2	501727
Sub-chassis, RF	1	461329
Trim strip (upper)	1	470118
Trim strip (center)	1	470119
Trim strip (lower)	1	470120
Vernier drive	1	470110

HARDWARE

Lockwasher, #4	15	582200
Lockwasher, #6	65	582300
Lockwasher, #8	3	582400
Lockwasher, $\frac{3}{8}$ "	8	582700
Nut, 3-48	6	570110
Nut, 4-36	23	570230
Nut, 6-32	41	570340
Nut, $\frac{3}{8}$ -32	14	570840
Screw, 3-48x $\frac{1}{4}$ "	6	560112
Screw, 4-36x $\frac{3}{8}$ "	23	560234
Screw, 6-32x $\frac{1}{4}$ "	5	560342
Screw, 6-32x5/16"	64	560343
Screw, 6-32x5/16", flat-head	2	563343
Screw, 6-32x7/16"	2	560345
Screw, 8-32x $\frac{1}{4}$ ", round-head	3	563442
Setscrew, 6-32 x $\frac{1}{4}$	2	563342
Setscrew, 8-32x $\frac{1}{4}$ ", headless	4	569001
Solder lug, #6	4	553005
Solder lug, $\frac{3}{8}$ "	1	553001
Spade lug, 6-32	4	568344
Washer, flat, #6 hole	6	580300
Washer, flat, #10 hole	3	580501
Washer, flat, 25/64"	7	580702
Washer, C	4	585002

WIRE, SOLDER, AND SPAGHETTI

Braid shielding 2 $\frac{1}{2}$ "	1	804005
Cable, 9-conductor, 30"	1	803021
Cord, Line	1	802001
Solder, 20 ft.	1	930005
Spaghetti, #20, 15"	1	812009
Wire, 2", red	2	801002
Wire, 3", orange	4	801003
Wire, 4", yellow	9	801004
Wire, 5", green	3	801005
Wire, 6", blue	2	801006
Wire, 7", violet	3	801007
Wire, 12", white/red	1	801012
Wire, 16", white/blue	1	801016
Wire, red stranded, #22, 9"	1	804086
Wire, shielded, insulated 16"	1	803025
Wire, shielded, 41"	1	803029
Wire, bare, #20, 38"	1	806038

S-METER PARTS LIST

Description	Part No.	Part No.
Control, 680Ω (S-Meter adjust)	1	390135
Dial light, #47	1	640002
Dial light socket	1	501728
Lockwasher, #4	1	582200
Lockwasher, 3/8" control	1	582700
Nut, 4-36	1	570230
Nut, 3/8" control	1	570840
Resistor, 820Ω, 1/2 watt	1	301821
S-Meter, with hardware	1	652205
S-Meter bracket	1	470132
S-Meter window	1	870033
Screw, 4-36 x 3/8" machine	1	560234
Screw, 6-32 x 5/16" machine	2	560343
Tape, 23" length	1	811007
Solder, 6"	1	930002
Wire, 2" red	1	801002
Wire, 3" orange	1	801003
Wire, 7" violet	1	801007
Wire, 11" white-brown	1	801011

TOOLS NEEDED FOR CONSTRUCTION

Stock No.	Description	Price*
46 N 852	Soldering iron, pencil type	\$5.26
50 N 132	6" Long-nose pliers	1.54
50 N 133	5" Diagonal cutters	1.34
45 N 796	6" Screwdriver	.72
43 N 831	6" Set-screw screwdriver	.27

ACCESSORIES

83 Y 727	S-Meter	9.50
83 Y 256	Crystal Calibrator	10.50

*Subject to change

VOLTAGE MEASUREMENTS

ALL VOLTAGE MEASUREMENTS ARE TAKEN FROM POINTS INDICATED TO GROUND WITH A VTVM. NO SIGNAL INPUT.

BAND SWITCH S-1 ON BAND 'A' POSITION.
S-2 IN OFF POSITION.

RF GAIN SET AT MAXIMUM.
AF GAIN SET AT MINIMUM.
S-3 IN MVC POSITION.

* VOLTAGES WITH S-3 IN BFO POSITION.

** VARIES WITH SETTING OF C-1

NOTES

RESISTORS INDICATED IN OHMS
K=1,000 OHMS
MEG=1,000,000 OHMS

TUNING RANGES	
BAND	FREQUENCY
A	.54 - 1.65 MC
B	1.6 - 4.6 MC
C	4.4 - 12.4 MC
D	12 - 30 MC

KNOB END
S-1 BAND SWITCH
(SHOWN IN BAND 'A' POSITION)
(FRONT VIEW)

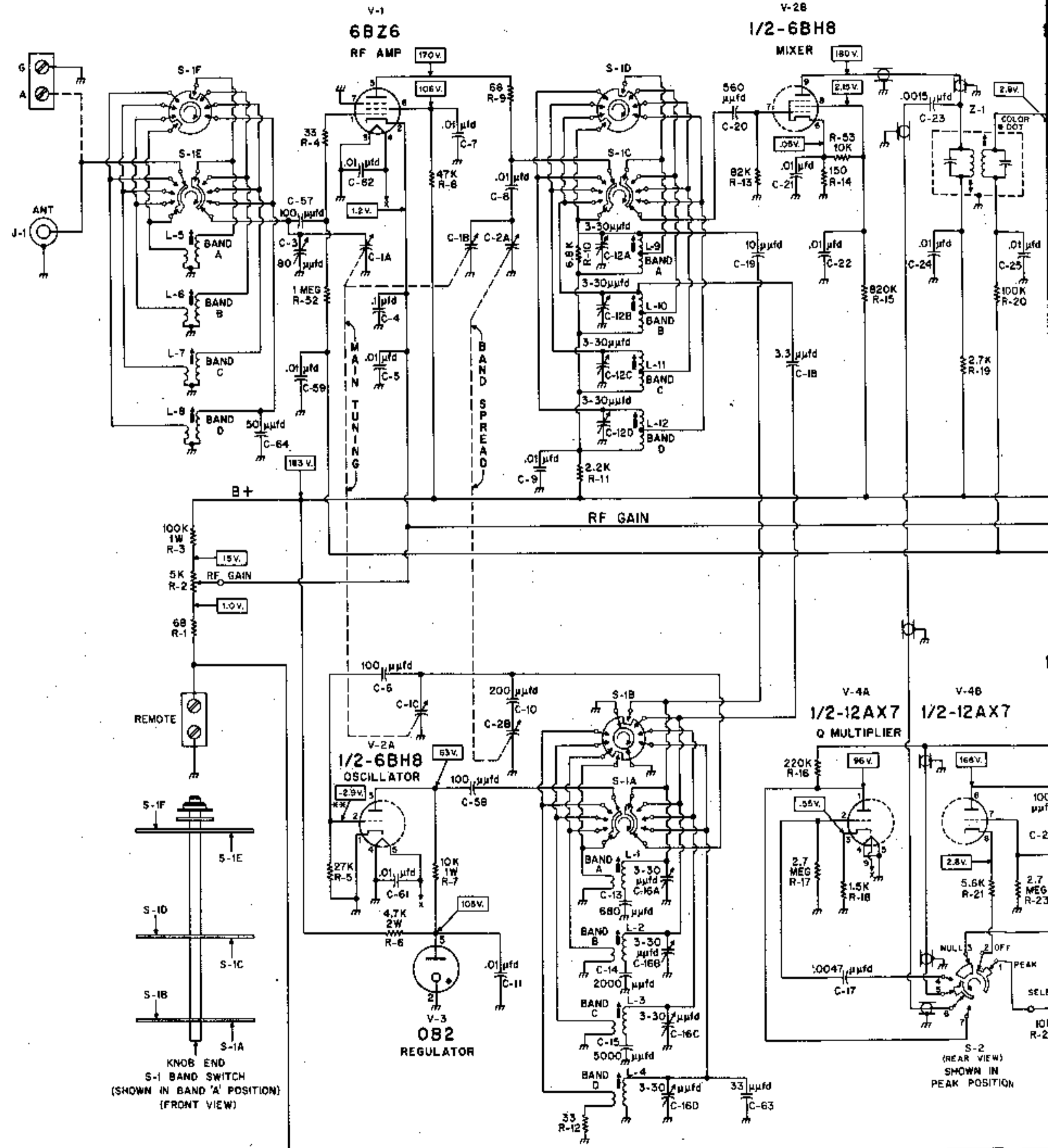

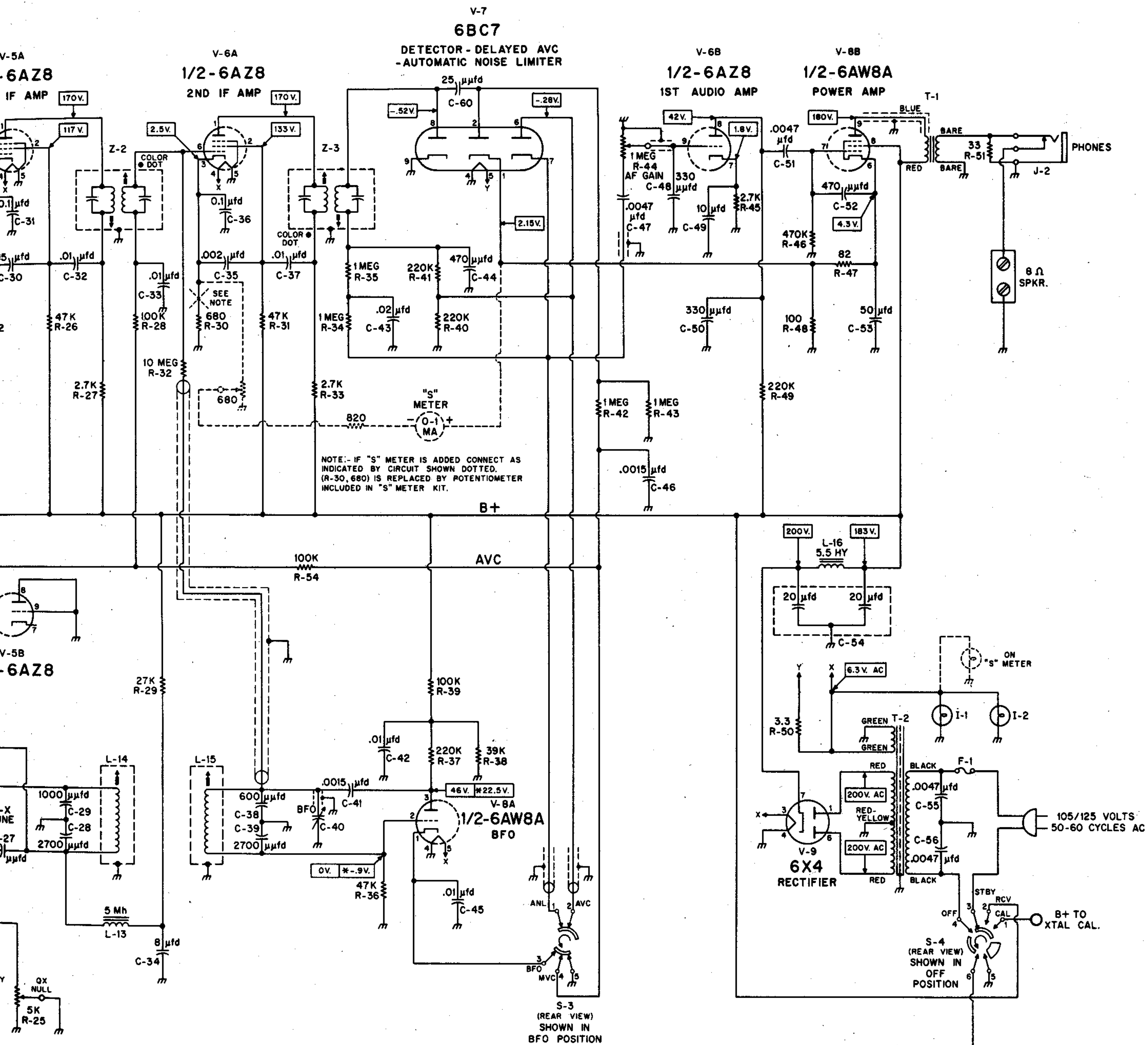

FIGURE 29 SCHEMATIC DIAGRAM

RESISTOR PARTS LIST

Description	Part No.
adjust)	1 390135
	1 640002
	1 501728
	1 582200
	1 582700
	1 570230
	1 570840
	1 301821
	1 652205
	1 470132
	1 870033
ne	1 560234
hine	2 560343
	1 811007
	1 930002
	1 801002
	1 801003
	1 801007
	1 801011

TOOLS REQUIRED FOR CONSTRUCTION

Description	Price*
n, pencil type	\$5.26
pliers	1.54
cutters	1.34
er	.72
screwdriver	.27

ACCESSORIES

.....	9.50
erator	10.50

VOLTAGE MEASUREMENTS

MEASUREMENTS ARE TAKEN INDICATED TO GROUND WITH SIGNAL INPUT.

S-1 ON BAND 'A' POSITION. POSITION.

RF GAIN SET AT MAXIMUM. AF GAIN SET AT MINIMUM. S-3 IN MVC POSITION.

* VOLTAGES WITH S-3 IN BFO POSITION.

** VARIES WITH SETTING OF C-1

TUNING RANGES	
BAND	FREQUENCY
A	.54 - 1.65 MC
B	1.6 - 4.6 MC
C	4.4 - 12.4 MC
D	12 - 30 MC

NOTES

RESISTORS INDICATED IN OHMS
100 OHMS
1000,000 OHMS

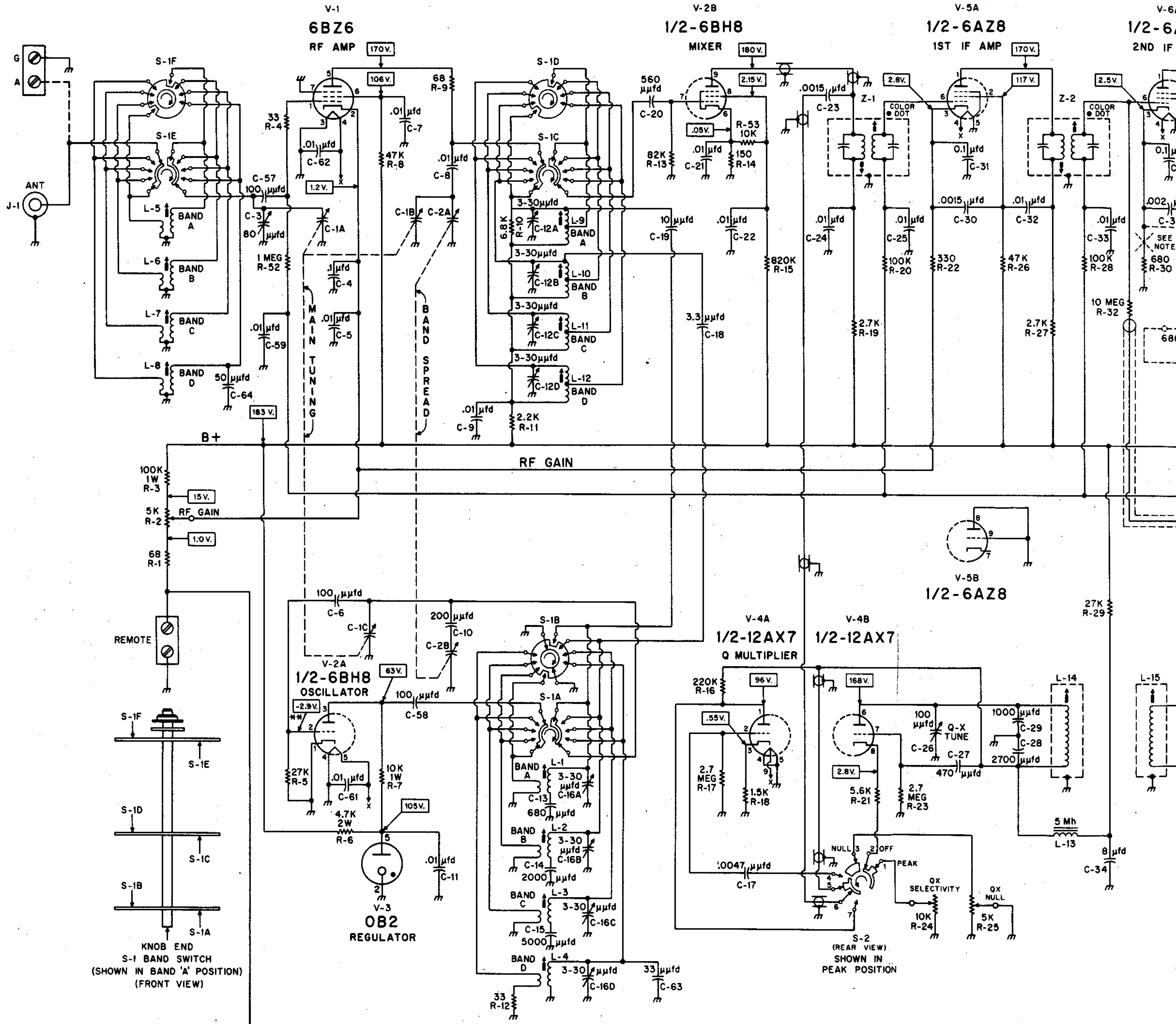

KNOB END
S-1 BAND SWITCH
(SHOWN IN BAND 'A' POSITION)
(FRONT VIEW)

S-2
(REAR VIEW)
SHOWN IN
PEAK POSITION



KNIGHT-KITS ARE YOUR BEST BUY THE FINEST ELECTRONIC EQUIPMENT IN KIT FORM. CREATIVE ENGINEERING AND USE OF PREMIUM QUALITY PARTS ASSURE SUPERIOR PERFORMANCE. THAT'S WHY KNIGHT-KITS ARE SOLD WITH THIS EXCLUSIVE GUARANTEE: *EVERY KNIGHT-KIT MUST MEET PUBLISHED SPECIFICATIONS OR WE REFUND YOUR MONEY.*

KNIGHT-KITS ARE "CONVENIENCE ENGINEERED" RESISTORS ARE CARD MOUNTED AND IDENTIFIED. WIRE IS PRECUT. SMALL PARTS ARE PACKAGED IN SEE-THROUGH PLASTIC BAGS. DETAILS SUCH AS THESE AND STEP-BY-STEP INSTRUCTION MANUALS MAKE KNIGHT-KITS EASIEST TO BUILD.

KNIGHT-KITS ARE THE FIRST CHOICE OF EXACTING BUILDERS OF ELECTRONIC KITS EVERYWHERE AND HAVE BEEN SINCE THE EARLY 20's. THERE IS AN OUTSTANDING KNIGHT-KIT AVAILABLE FOR EVERY REQUIREMENT. EACH IS A REWARDING ADVENTURE IN KIT CONSTRUCTION. YOU WILL BE PROUD TO BUILD AND OWN A KNIGHT-KIT.