

# ***knight***<sup>®</sup>

TR-106 6 METER  
TRANSCEIVER

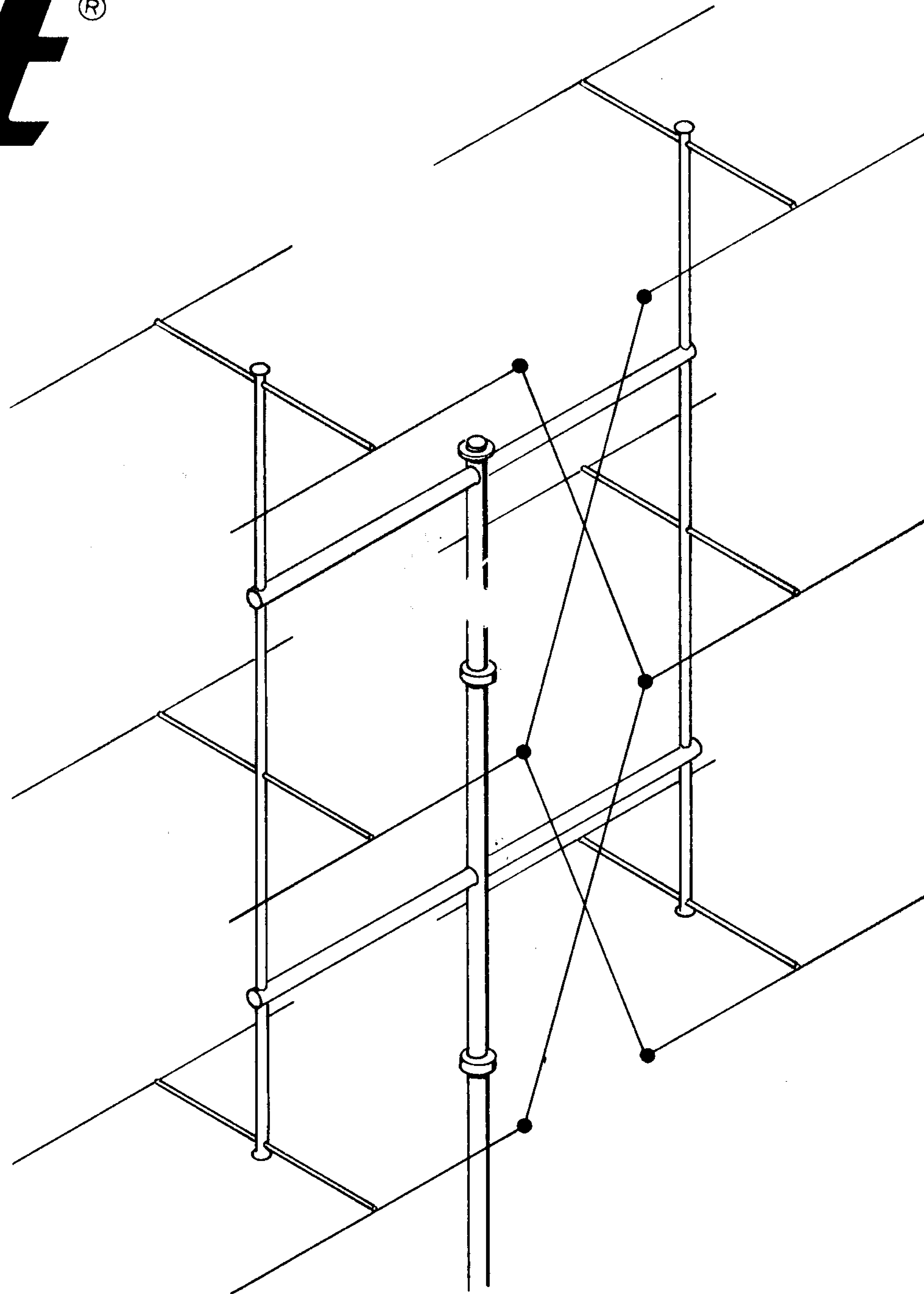

## **OPERATOR'S MANUAL**

# SPECIFICATIONS

## TABLE OF CONTENTS

	Page
<b>Specifications</b> .....	2
<b>Control Functions</b> .....	3
<b>Step by Step Operating Instructions</b> .....	4
<b>Operating Hints</b> .....	5
<b>Propagation</b> .....	6
<b>Operation</b>	
Antennas .....	7
Mobile Installation Considerations .....	8
<b>Television Interference</b> .....	11
<b>Maintenance</b>	
Alignment .....	14
Trouble-shooting .....	16
<b>Circuit Description</b> .....	17
<b>Warranty</b> .....	24
<b>Schematic Diagram</b> .....	Insert
<b>Parts List</b> .....	Insert

### RECEIVER SECTION

<b>Audio Output:</b>	5 watts or more
<b>Intermediate Frequencies:</b>	1st I.F.—tunable from 15.6 to 17.6 mc 2nd I.F.—1650 kc
<b>I.F. Rejection</b>	50 db or better for 1st I.F. 70 db or better for 2nd I.F.
<b>Image Rejection:</b>	55 db or better
<b>Input Impedance:</b>	50 ohms nominal
<b>Selectivity:</b>	6 db down at 8 ke
<b>Sensitivity:</b>	0.5 microvolt for 10 db $\frac{S+N}{N}$ ratio

### TRANSMITTER SECTION

<b>Frequency Control:</b>	Fundamental cut 8 mc crystals or VFO at 8.333 to 8.666 mc
<b>Frequency Range:</b>	50 to 52 mc
<b>Modulation:</b>	Amplitude modulated plate and screen, limited to approximately 95%
<b>Output Impedance:</b>	30 to 90 ohms nominal (with VSWR of 3:1 or less)
<b>RF Power:</b>	Input: 15 watts nominal

### POWER SUPPLY (solid state):

<b>Power Requirements:</b>	110-130 volts, 60 cycle AC—90 watts re- ceive/105 watts transmit 12-15 volts DC—6.8 amps receive/8.1 amps transmit
<b>Rectifier:</b>	Full-wave voltage doubler with silicon di- odes

### TUBE COMPLEMENT:

<b>Receiver:</b>	6DS4—Nuvistor, RF amplifier 6EA8—1st mixer/oscillator 6EA8—2nd mixer/oscillator 6BZ6—1st I.F. amplifier 6BZ6—2nd I.F. amplifier 6AL5—Detector/ANL diode 12AX7—Audio/mic preamp 6L6GC—Audio output/modulator
<b>Transmitter:</b>	12DK6—Oscillator/tripler 12AQ5—Buffer/doubler 2E26—Final power amplifier

**Size:** 5 $\frac{1}{2}$ " x 13 $\frac{1}{8}$ " x 11"

## CONTROL FUNCTIONS

This short description of the function of each control available from the front and rear of your transceiver, supplies background information for proper operation of your transceiver. For step-by-step operating instructions, see the next section of this manual.

**Tuning Dial**—tunes the receiver section to the desired frequency.

**Meter**—in receiving function, it indicates the relative strength of the incoming signal. The upper scale is calibrated in “S” units from 1 to 9 and up to 30 db over S-9. (S-9 = 50  $\mu$ V input signal).

In the transmit function, it acts as a relative power output indicator. It is used during loading and adjustment of the transmitter.

Use the meter for precise tuning of the receiver; adjust the Tuning Dial for maximum indication on the meter.

The meter is also used as the indicating device for the “spotting” function.

**TRANSMIT Indicator**—lights when the transceiver is in the transmit function.

**LOAD**—matches the output of the transmitter to the antenna. It can be used to match antenna impedances of 30 to 90 ohms, providing the VSWR is 3:1 or less.

**PLATE**—is used to resonate the plate circuit of the transmitter final amplifier at the operating frequency.

**PHONES**—for listening to the receiver with headphones. Use low-impedance phones—4 to 16 ohms. The speaker is muted when a phone plug is inserted into this jack. Also, a remote speaker can be connected to this jack. If you use high impedance phones, they must be shunted by an 8 ohm 2 watt resistor.

**TRANSMIT-RECEIVE**—activates the transmitter or the receiver function. This switch may be used in conjunction with a microphone which does not have a push-to-talk button. When left in RECEIVE, a microphone push-to-talk button will operate as the transmit/receive switch. This switch is also used when tuning and adjusting the transmitter.

**NOTE:** The microphone provided with this transceiver has a shorting connection across the microphone element when the push-to-talk button is in the receive position (button out). Thus, you can make transmitter adjustments without fear of audio pick-up from the microphone, by operating the front panel TRANSMIT-RECEIVE switch.

**MULT**—resonates the plate circuit of the transmitter oscillator/tripler stage to the operating frequency. Its adjustment determines the grid drive to the final amplifier.

**CRYSTAL**—selects the transmitter frequency-determining crystal or VFO input. Positions 1, 2 and 3 correspond to the numbered crystal sockets to the left of this switch.

**SPOT-OFF**—provides a transmitting frequency spotting function. When set to SPOT, the Tuning Dial can be set to the exact transmitter frequency by observing the Meter indication. The SPOT function operates for both crystal controlled and VFO operation. Thus, you can set the receiver and the transmitter to the exact same frequency.

**RF GAIN**—varies the output level of the RF stage. This control is in the cathode circuit of the 2nd Mixer, therefore it varies the output of this stage.

**POWER-OFF**—turns power on and off.

**AF GAIN**—varies the level of the audio signal for the receive function. This control is in the grid circuit of the audio pre-amp.

**The microphone** is connected to the jack to the left of the PHONES jack.

**ANT connector on the rear panel.** Attach the coaxial cable from your antenna system to this connector.

**The 12-pin power connector** is for the input power; either 120 volts AC or 12 volts DC can be used for power. Two power cords are available—one for 120 volts and one for 12 volts.

**VFO PWR**—Power is available from this connector for an external VFO; 30 ma at 200 VDC and 0.3 amp at 12.6 VAC.

**S MTR**—is used to set the meter on the front panel to zero, when no signal or noise is being received.

**VFO INPUT**—connect the output from a VFO to this jack.

**ANL-ON** (automatic noise limiter)—when in the ON position, it switches an automatic noise limiting circuit into the receiver. This reduces pulse-type noise such as automobile ignition, sharp bursts of static, etc. When you turn this switch ON, the volume of the receiver may drop slightly; this is normal, and has no effect on the sensitivity of the receiver.

## STEP BY STEP OPERATING INSTRUCTIONS

**You must have a current Amateur Radio license to operate this transceiver on the air.** A Novice Class License does not permit use of this transceiver. Before you actually start to operate your transceiver, we suggest that you turn to the OPERATION section of your manual. A number of important points are discussed and specific information is given about antennas, mobile installations and general operating considerations.

- [ ] Connect the microphone to the microphone connector on the front panel.
- [ ] Connect an antenna to the ANT connector on the rear of the transceiver.
- [ ] Connect the proper power cord to the power connector on the rear of the chassis and to the power source.

**CAUTION: NEVER TOUCH ANY OF THE WIRING OR REMOVE ANY TUBES WHILE THE UNIT IS ON. BE ESPECIALLY CAREFUL TO AVOID CONTACT WITH THE PLATE CLIP OF THE 2E26 TUBE. VOLTAGES USED IN THIS UNIT ARE DANGEROUS.**

### TO RECEIVE

- [ ] Set TRANSMIT/RECEIVE switch to RECEIVE and SPOT to OFF.
- [ ] Turn the POWER switch on.
- [ ] Turn RF GAIN maximum clockwise.
- [ ] Adjust AF GAIN for desired level of sound.
- [ ] Adjust the tuning dial to the desired frequency.
- [ ] To set the S meter to zero, disconnect the antenna and adjust the SMTR control on the rear of the chassis so the meter needle rests at 0.
- [ ] If excess static type noise is present in the signal, set the ANL switch on the rear of the chassis to ON.

**NOTE:** Any noise that you may hear in the transceiver is almost totally from external sources. The receiver itself is exceptionally quiet. Remember, steady, high noise levels cannot be eliminated by the ANL circuit. When the level of the noise approaches the level of an incoming signal, switching in the ANL will reduce the level of the signal, along with the noise. Noise problems can not be solved internally (in the transceiver); they must be solved at the source of the noise.

This brief discussion will be especially helpful if you use the transceiver in a mobile installation. See MOBILE INSTALLATION CONSIDERATIONS.

### TO TRANSMIT

**Caution:** Never operate the transmitter without an antenna or dummy load connected to the ANT jack. Also, never operate without a VFO or a crystal.

First, determine if you are going to use a VFO or crystals for determining the transmitter frequency. For VFO operation, use a VFO capable of at least 15 volts RMS output, which covers the range 8.333 to 8.666 mc. Crystals must be of the fundamental-cut type in the range of 8.333 to 8.666 mc. For MARS, use a standard MARS crystal (8.33 mc).

Note that the multiplication factor for crystal or VFO frequency is 6. Thus, if you want to find the crystal frequency that will place you on a specific frequency in the 6 meter band, divide by 6.

- [ ] Plug your crystal into one of the crystal sockets or plug the output from your VFO into the VFO INPUT connector on the rear of the chassis. Set the CRYSTAL VFO switch to the correct position (VFO or 1, 2 or 3 depending on the position of the crystal).

**CAUTION:** When you use the matching VFO with this transceiver, **be sure the VFO power plug is properly connected to the socket on the transceiver — The screw-head positioned toward the 12-pin power connector.**

- [ ] With POWER on and antenna connected to the ANT connector on the rear of the chassis, set TRANSMIT/RECEIVE switch to TRANSMIT.
- [ ] Adjust MULT, PLATE and LOAD for maximum meter reading.

## OPERATING HINTS

The transmitter is now adjusted for this operating frequency. A change in operating frequency of up to 150 kc (total, 300 kc) will not require re-tuning the transmitter.

To modulate, press the microphone button and speak into the microphone. You will find that a setting of the Mic Gain control (screw-driver adjustment on the right side of the chassis) at mid-range will result in adequate modulation.

Any type of high impedance microphone may be used with this transceiver. A carbon mic can not be used.

If you are using a desk-type microphone without a press-to-talk switch, use the TRANSMIT-RECEIVE switch on the transceiver. If you use the microphone that comes with the transceiver, or any microphone that has a press-to-talk button, leave the TRANSMIT-RECEIVE switch in the RECEIVE position and use the mic button for transmitting.

The microphone that comes with the transceiver has a shorting connection across the microphone element. Thus, no sounds are picked up by the microphone when the TRANSMIT-RECEIVE switch is in the TRANSMIT position. This permits tuning operations to be made without extraneous sounds being transmitted.

For precise setting of the Mic Gain control, adjust it for the best sound by signal report or by monitoring the modulation pattern on an oscilloscope. Since the modulation circuit has been deliberately designed to limit modulation to 95%, a high setting of the Mic Gain control will result in distortion of the audio, rather than over-modulation.

**NOTE:** If you want to tune the receiver to the exact frequency of the transmitter, turn RF GAIN maximum counterclockwise to CAL and turn SPOT on. Adjust the tuning dial for maximum meter reading. The receiver is now tuned to the same frequency as the transmitter. Return SPOT to OFF and readjust RF GAIN as required.

When you use the spot feature, you may notice two points on the tuning dial where a meter reading is obtained. The lower frequency point is the correct one. These two points will be about 1 mc apart.

Here are a few points that should be kept in mind as you operate your transceiver.

Remember to identify your transmissions at least every 10 minutes. Sometimes it is easy to forget, when you become engrossed in a "rag chewing" session. Identify by station call at least once in each 10 minutes.

F. C. C. regulations prohibit the use of amplitude modulated transmissions from 50.000 to 50.100 mc; this segment of the band is for c.w. only. Keep this in mind, especially when working DX to other countries. Some countries, Canada for example, permit use of this segment of the band for a.m. operation. So, just a word of caution, do not call back *on their frequency* if they are below 50.100 mc.

If you have not been active on 6 meters, or have just moved into a new area, before you start extensive activity, check local nets and calling frequencies. Avoid using the same frequencies that nets utilize. Keep in mind that operation in the VHF bands is considerably different from the lower bands. Activity is concentrated in local areas and on specific frequencies.

Since so much activity on the VHF bands is associated with nets, here are some handy conversion figures to keep in mind when handling traffic and other functions requiring the recording of Greenwich Mean Time.

To obtain GMT, add 4 hours to Atlantic Standard Time, 5 hours to Eastern Standard Time, 6 hours to Central Standard Time, 7 hours to Mountain Standard Time and 8 hours to Pacific Standard Time.

**For operation under the Military Affiliate Radio Service, contact the net control station of the local net. You will be supplied with the necessary information and forms for application. Do not operate on the MARS channel until you have received proper authority. You must use a crystal for the MARS channel; do not use VFO control.**

One last thing—support and adhere to *The Amateur's Code*. The Amateur is Gentlemanly . . . Loyal . . . Progressive . . . Friendly . . . Balanced . . . Patriotic.



## PROPAGATION

The VHF bands seem to be the bands of the future. Activity and interest in the higher frequency bands is swiftly increasing. Proposed changes in regulations, crowded conditions on the lower bands and a renewed interest in experimentation, have all contributed to this.

Most "hams" concentrate on DX communications. The greater the distance, the more enjoyable the contact. Normal ground-wave communications on 6 meters, with a transceiver of this power level will be from 25 to 50 miles. This range will vary with the type and height of the antenna used. Ranges over 100 miles are possible with a multi-element array. Mobile stations are limited to shorter distances, due to the antennas involved.

With higher power and elaborate antenna systems, the normal radio horizon can be extended to about 200 miles. This is greater than the "line-of-sight" distance, because the earth's atmosphere bends the radio waves slightly. Thus, the radio wave follows the curve of the earth for a distance greater than the line-of-sight path.

Distances greater than the radio horizon are common. This is due to "skip". Skip varies with many conditions. The drawing provided will serve to illustrate this point.

Tropospheric propagation extends up to approximately 800 miles. Many factors enter into this type of propagation, but basically, the radio wave is bent by the troposphere and is returned to the earth at some point beyond the normal radio horizon.

Sporadic E skip communications result from bounce off of ionized layers of dust or "ion clouds" at altitudes of 50 to 70 miles. This can produce communication ranges of up to 1500 miles. Double skip can greatly increase this distance. Propagation from "aurora borealis" curtains occasionally occurs in a similar manner. This is usually limited to northern latitudes.

Radio reflection from the F 2 layer is the most common method of DX communication in the VHF bands. Distances of over 2000 miles are quite normal.

Propagation in the VHF bands depends greatly on the sun-spot activity. Amateur Radio periodicals usually report current conditions and will give you information to help predict opportunities for DX. Local nets will probably have up-to-date information on propagation conditions.

The entire field of propagation prediction is still experimental and much study is being done by industry, as well as "hams". For reference information, we recommend *The Radio Amateur's Handbook*, Editors and Engineers *Radio Handbook* and your local technical library.

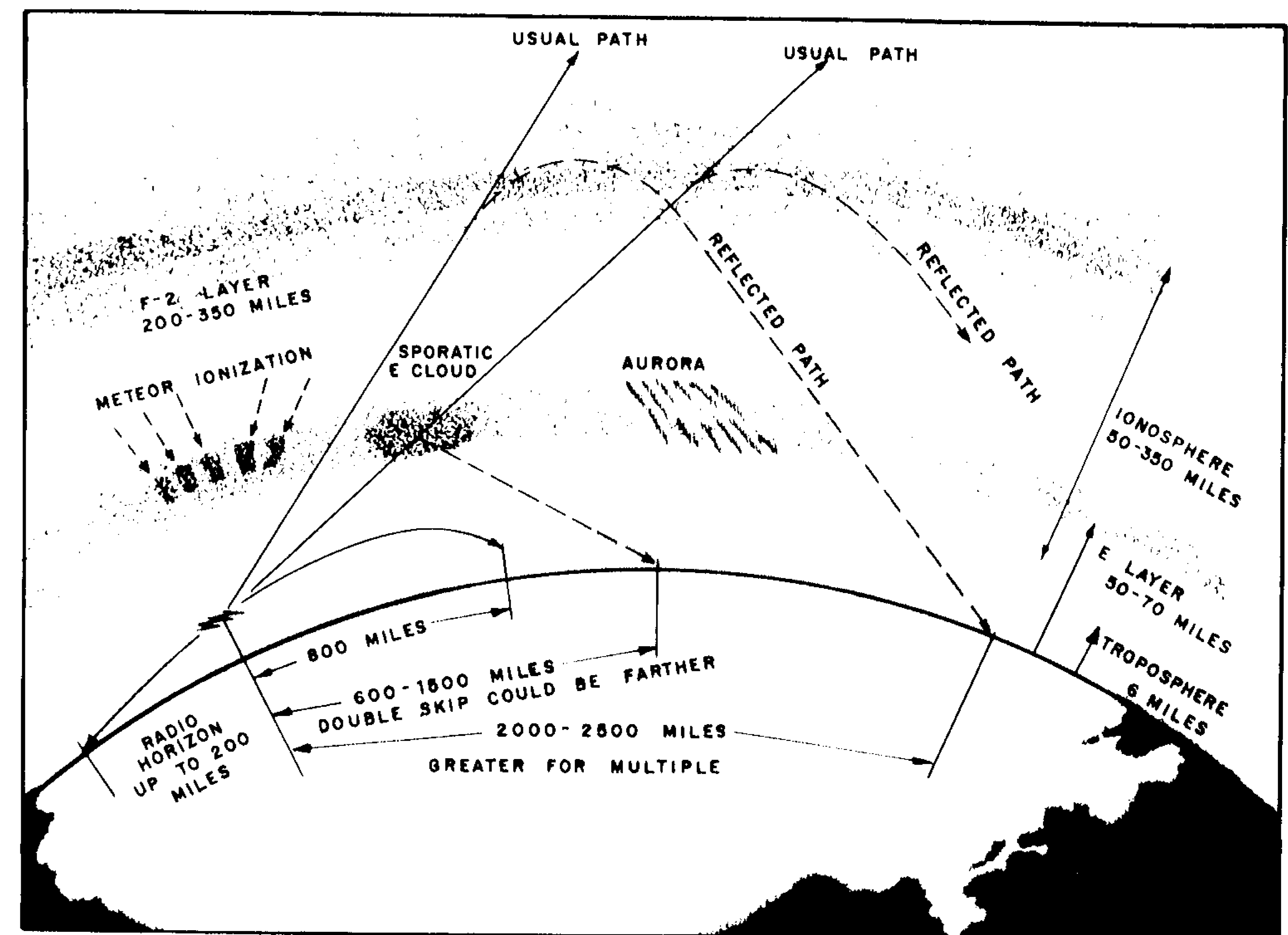

## OPERATION

### ANTENNA SYSTEM

The antenna system includes the transmission line, and it is very important that you use the correct type of transmission line. The transmission line should be of the coaxial type and should have an impedance equal to the antenna impedance.

Since your transceiver is designed to operate most efficiently into a 30 to 90 ohm load, it is best to use a type of coaxial cable with an impedance of 50 to 52 ohms. We suggest type RG-58/U for short lengths and RG-8/U for long lengths.

Generally speaking, you should keep the length of the transmission line to a minimum. Remember that line losses increase with frequency. In the VHF bands, loss can be considerable. Use foam-insulation coax for best results.

If the transmission line must be long, keep it to exact multiples of a half-wave length, that is, multiples of 9.3 feet. This will assure a proper impedance match and thus maximum transfer of power from the transmitter to the radiating antenna.

The above discussion is as important for reception as it is for transmission. If a mismatch exists between the antenna and the receiver, the excellent sensitivity and signal to noise ratio of the receiver will be defeated.

### FIXED STATION ANTENNAS

The most popular fixed station antenna is a directional array. It may be a relatively simple beam, or a complex collinear system.

Beam antennas provide maximum gain, maximum directivity and usually are horizontally polarized. The directivity can be a disadvantage for net operation, but the other advantages usually outweigh this problem. Since a beam antenna is directional, it greatly reduces noise and interference from all other directions. This can be a decided advantage in the VHF bands where man-made noise is a problem.

Polarization is an important consideration. On the 6 meter band, horizontal polarization is more popular than vertical. Check with local hams for information on local preference, since it is important to keep the same polarization over line-of-sight and ground wave communications. Skip conditions

usually distort the polarization; thus, for DX operation in this band, polarization is not as great a consideration. Also, keep in mind that most man-made noise is vertically polarized. Vertical polarization has two advantages, omni-directionality (for net operation) and TVI is less of a problem (since TV antennas are horizontally polarized).

A simple dipole antenna is very suitable for a temporary antenna system. Keep in mind that transmission and reception is broadside to its length. The illustration shows how to construct a simple dipole.

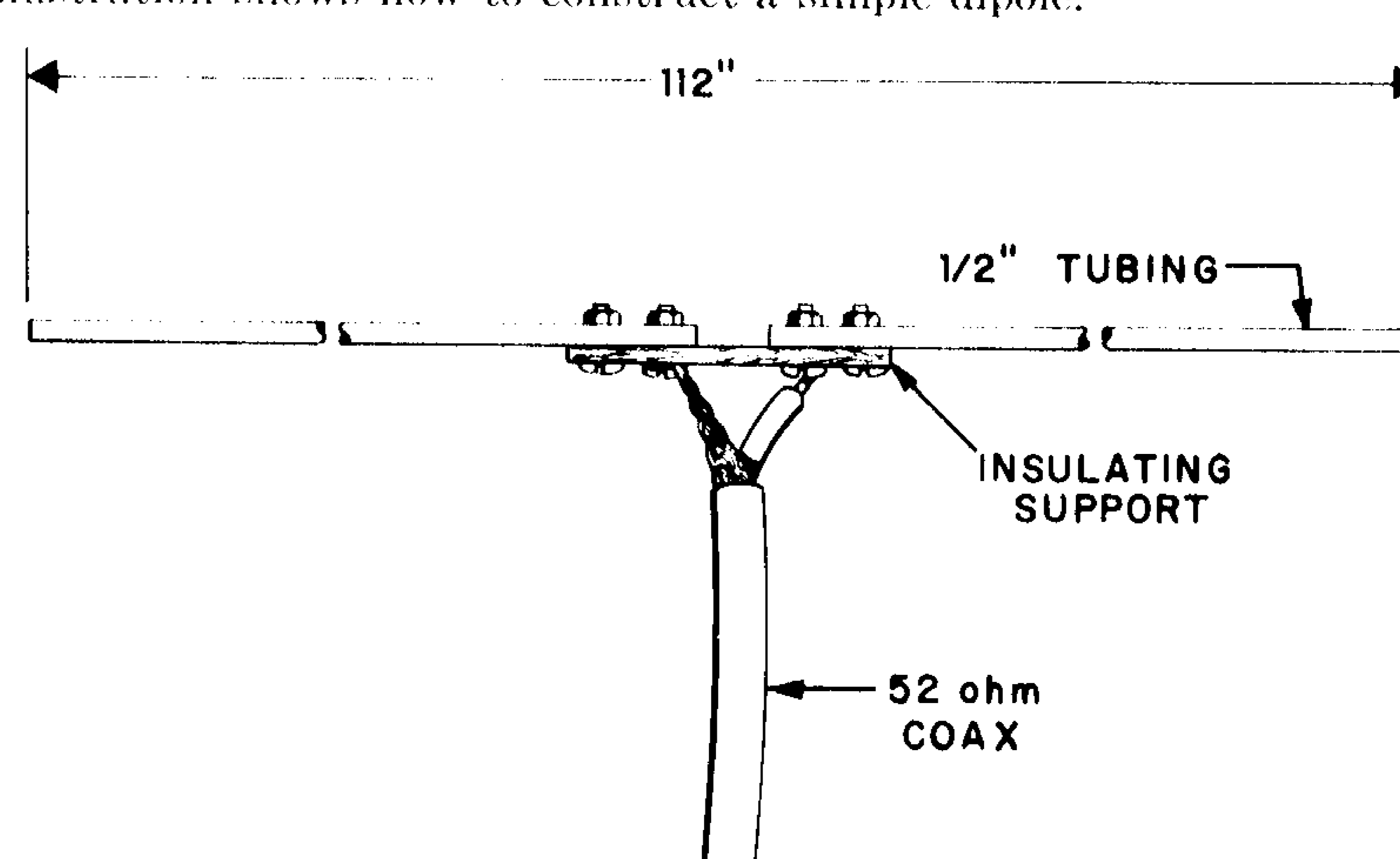

Do not use a random length of wire for an antenna in the VHF bands. It is imperative that "tuned" or "resonant" antennas be used for these frequencies.

For best results, we highly recommend use of commercial antennas. The antennas available on the market today are economical and come with all the necessary instructions and matching devices for greatest efficiency. When performing adjustments on a commercial antenna, always make the required adjustments with an SWR meter to be sure you obtain optimum results.

A separate RF ground is not required for your transceiver. However, a DC ground may be necessary to keep the chassis at ground potential and avoid the possibility of minor shocks due to normal transformer leakage. The antenna system should be adequately grounded; the transceiver will be grounded through the shield of the coaxial cable. Always use a lightning arrester for your antenna system.

### MOBILE STATION ANTENNAS

The two popular antennas for 6 meter mobile operation are the vertical or whip antenna and the halo antenna.

The whip antenna is more efficient than the halo. It is vertically polarized, which is a disadvantage for noise, since man-made noise is primarily vertically polarized.

The halo provides a horizontally polarized signal; this should be considered if you intend to communicate with fixed stations (which usually use horizontally polarized antennas).

Again, we recommend that you use commercial antennas. They come complete with mounting hardware and adjustment instructions.

The location of the mobile antenna has a great effect on the antenna efficiency and directivity.

Antennas mounted in the center of the roof of a vehicle will radiate equally in all directions.

A bumper mounted antenna radiates in a pattern directly in front of and to the rear of the vehicle, with maximum radiation directly away from the vehicle.

Since the normal  $\frac{1}{4}$  wavelength whip antenna is too long (56") for roof mounting on a vehicle, the antenna is shortened and a loading coil is utilized to provide the proper electrical length. As a result, the over-all efficiency is reduced and the nondirectional advantage is defeated. Thus, the bumper mounted whip antenna will give superior results in most cases.

A few general rules should be followed for proper installation of the mobile antenna:

1. Keep it as far as possible from the main metal bulk of the vehicle.
2. Keep as much of it as possible above the highest point of the vehicle or boat.
3. During operation it must be kept vertical. Thus it should be mechanically rigid so it will maintain a vertical position when the vehicle or boat is in motion.
4. Mount it as far as possible from sources of noise (ignition system, gauges, etc.) and convenient for transmission line routing away from these noise sources.

**An antenna mounted in a boat requires a ground.** This can be either the metal hull or ground made of tin-foil or copper sheeting. This ground should cover an area of 12 square feet or more. Be sure the transceiver has an adequate ground also.

### MOBILE INSTALLATION CONSIDERATIONS

Safety and convenience are the primary considerations for mounting any piece of mobile equipment. All controls must be readily available to the operator without interfering with the movements necessary for safe operation of the vehicle. Be sure all cables are clear of the brake and accelerator.

**CAUTION:** Check with local authorities about mobile operations restrictions; some states prohibit the use of a hand microphone while a vehicle is in motion.

Also, thought must be given to the convenience of passengers—will they have adequate leg room?

A last, and extremely important requirement is the ease of installation and removal. Mount the transceiver so that it can be slipped in and out very easily.

The most common mounting position for a transceiver of this size and weight is directly over the driveshaft hump. Due to the weight of this unit, we do not recommend that you mount it suspended from the dash.

Do not mount the transceiver in the path of the heater air stream. Also, avoid mounting in a place that will interfere with the glove compartment or ash tray.

Be sure the chassis of the transceiver is electrically connected to the ground system of the vehicle or boat. Use a separate ground wire to be sure.

### BATTERY

When used in mobile operation, your transceiver must obtain power from whatever source is available in the vehicle or boat. In most cases this is a storage battery. The power required by your transceiver will be in addition to the power normally drawn by the ignition system, lights and accessories.

This extra power drain must be carefully considered before installing your transceiver. The battery must be capable of handling the extra load, additional fusing devices may be required and the generator or alternator must be adequate for the installation.



**Also, before installing the transceiver, be sure the vehicle has the correct ground system.** Most vehicles manufactured in the United States since 1956 have a negative ground electrical system. **Severe damage may result if you attempt to use this transceiver on a positive ground system.**

Do not allow the battery to become discharged by adding this extra load. In cold weather this is especially important, because the power available from a storage battery drops sharply as the temperature decreases. Have the battery checked before installing the transceiver and also have the regulator adjusted to compensate for this increase in current drain.

It will be a good idea to check the current rating of the generator or alternator. Be sure its current rating is not exceeded with the additional current drawn by the transceiver. The current rating of the generator or alternator should not be exceeded even under peak loads: the heat developed in the windings may permanently damage it.

You can use the auto accessory plug supplied to connect your transceiver to the vehicle's power source. However, it is better to connect the DC power cord directly to the accessory terminal of the ignition switch. This will prevent unauthorized usage of the transceiver, and will also prevent you from leaving the transceiver on unintentionally.

## **NOISE**

Your vehicle or boat can be the cause of much noise interference. Since the receiver section of your transceiver is very sensitive, it will pick up even the smallest noise signals and amplify them. A point worth mentioning is that the frequency components of ignition noise peak at about 50 mc. Thus, ignition noise problems will be more prominent in the 6 meter band than any other portion of the spectrum.

Remember, your transceiver has a very sensitive receiver and it will pick up even the smallest trace of ignition noise. Any noise that you hear in the transceiver is almost totally from external sources. The receiver itself is exceptionally quiet. Steady, high noise levels can not be eliminated by internal circuits (such as the ANL circuit). When the level of the noise approaches the level of an incoming signal, switching in the ANL will reduce the level of the signal, along with the level of the noise. Noise problems can not be solved internally (in the transceiver); they must be solved at the source of the noise.

If you wonder if the noise is from your ignition system, the transceiver or an external source, try this simple test. Turn your ignition switch off and set it to ACC (accessories). This turns off the ignition, but supplies power to the transceiver. Most of the noise will disappear--indicating that the source of noise is your ignition system.

This interfering noise can be generated anywhere in the electrical system of the vehicle or boat. The first step in reducing or eliminating this noise is to locate the source of the noise.

## **Ignition System**

The most common source of noise is the ignition system. This noise can be identified by the fact that it varies with the speed of the engine. It consists of a series of popping sounds occurring at a regular rate that will vary with the speed of the engine and stop when the ignition is turned off.

There are a number of things that can be done to reduce this type of noise:

1. Use only the "radio suppression type" high voltage ignition wire. Most new cars come already equipped with this type of wire.
2. Inspect the high voltage ignition wire and all connections made with this wire. Old ignition wire may develop leakage resulting in hash.
3. If noise still persists, replace the spark plugs with spark plugs that have suppressor resistors built-in. Be sure to use the correct type for your vehicle.

The best solution and most nearly perfect cure is to use a top-quality, complete ignition system shielding kit. We highly recommend use of one such as the Johnson/Hallett *Eliminnoise* or a kit of comparable quality. It will provide maximum suppression of all ignition noise.

### Generator

Probably the next most common source of interference is the generator. Generator noise shows up as a musical whine that is present whenever the engine is running. The pitch of the whine varies with the speed of the engine.

To eliminate this type of interference, connect a coaxial type 0.5  $\mu\text{f}$  capacitor from the ARMATURE terminal of the generator to the metal case of the generator. Also, connect a high quality (mica) 0.001  $\mu\text{f}$  capacitor across (in parallel with) the 0.5  $\mu\text{f}$  capacitor.

In serious cases of generator interference, it may be necessary to install new brushes on the generator. This will be especially true of generators in older vehicles.

Occasionally, in an old generator, the shaft bearings may be worn to a point where they add to the noise interference. In these cases, it is best to replace the generator.

### Regulator

Regulator noise appears as a "hash" or an irregular raspy noise. This noise can be eliminated by connecting a 0.25  $\mu\text{f}$  coaxial type capacitor from the battery terminal (BAT) to the case of the regulator and another 0.25  $\mu\text{f}$  coaxial capacitor from the generator armature terminal (ARM) of the regulator to the case of the regulator.

You may also find it necessary to connect a 3.3 ohm carbon resistor in series with a 0.002  $\mu\text{f}$  coaxial capacitor from the field terminal (FLD) to the case of the regulator.

### Gauges

Another possible source of annoying interference is the gauges. Gauge noise usually shows up as a periodic, rasping sound. When in doubt about gauge interference, install a 0.1  $\mu\text{f}$  coaxial capacitor directly from the "hot" terminal on the gauge to the chassis of the vehicle. Also, a tachometer can be a source of noise; install a 0.1  $\mu\text{f}$  coaxial capacitor on the lead from the ignition coil.

### Static Noise

The discharge of static electricity developed on the vehicle may cause some interference.

Static can be developed in the wheels, by the rotation of the tires and brake drums. This type of interference can be eliminated by:

1. Installing wheel static collectors under the hub caps of the front wheels. These static collectors can be obtained at any automobile or radio parts store.
2. Inject antistatic powder in the tires. This too can be obtained at an auto parts store.

The body of a vehicle can also develop static when driven at high speeds. This static electricity discharges off the end of the antenna. A piece of vinyl plastic tubing secured over the end of the antenna will effectively reduce this type of interference.

### Loose Bonds

Loose linkages or bonds on the vehicle can cause interference. This will be especially noticeable when driving over rough roads. To eliminate this type of noise:

1. Tighten up all bolts and linkage connections.
2. Use braided shield to bond various suspected parts to the frame of the vehicle (for example, and especially, the tailpipe and muffler).

Generally speaking, interference noise can be generated by any device or connection that carries electrical current. Any device that can generate a spark should be suspected. Bypass any suspected wire to the frame of the vehicle with a high quality 0.1  $\mu\text{f}$  capacitor (preferably the coaxial type).

For additional material on the reduction of interference noise, we suggest you refer to the Editors and Engineers Radio Handbook and The Radio Amateur's Handbook published by the ARRL. These books should be available at most local libraries.

# TELEVISION INTERFERENCE

Operation on the amateur VHF bands results in the greatest frequency of TVI complaints, as compared to the more popular low frequency bands. Fear of causing TVI has probably been a major factor for lack of universal interest and activity on the VHF bands. However, if you keep a few things in mind and are prepared to provide help and assistance to TVI complainants, your aggravation with this subject can be held to a minimum.

It is important to take a well-organized, common-sense approach to the problem. Any TVI situation resolves itself into three areas:

1. The amateur's transmitter.
2. The amateur himself.
3. The receiver.

The first and third subjects are purely technical and usually can be solved quite easily. The second is one of personal relations and usually is the most difficult. Unfortunately, because it is not technical, the amateur often does not devote as much consideration to this most important part of the TVI problem.

Let's consider them in the order mentioned:

## TRANSMITTER

*Keep your own signal clean!* This should be the basic rule for every amateur, especially the VHF man.

This transceiver has been designed with this consideration uppermost. As a result, you can be very confident that any TVI problem is not a fault of your transmitter, unless it is malfunctioning.

However, let us mention a few things to aid you in your TVI investigation. The prime TVI problem will be noted on channel 2 (54 to 60 mc). This is not the fault of the transmitter, but rather due to the lack of selectivity in the front end of the TV receiver (more of that later). Channel 2 interference can only be solved at the receiver.

Interference on other than channel 2 could possibly be solved at the transmitter end. It could be caused by improper adjustment of T-6, the Buffer/Doubler coupling transformer. This would result in coupling and radiation

of harmonics other than the 2nd harmonic from V-8 Doubler stage. Recheck the adjustment of T-6, following the instructions given in the MAINTENANCE section of this manual. A second solution is to use a low-pass filter at the output of the transceiver. Use a filter with a sharp-cutoff frequency of 52 to 56 mc. Such a low-pass filter will not only filter out any harmonics present in the output from the transmitter, but it will also filter out any strong commercial (FM or TV) signal that might otherwise cause birdies in the receiver.

## THE OPERATOR

Very seldom is the operator the problem, but he is the one standing in-between the other two subjects—the transmitter and the receiver. He, somehow, must bridge the gap so he can advise the complainant about the receiver.

The amateur is in a touchy situation. He is in the right and yet he is blamed for the problem. He must be courteous and considerate.

Remember that your neighbor probably looks at your hobby, and you, with a certain amount of distrust. You are out of the ordinary and maybe even have a touch of the "mad scientist". To say nothing of being the one to blame for disturbing his favorite TV program!

Keeping this attitude in mind, when you receive a complaint, be understanding and do not be afraid to admit that your signal is the one that is interfering with his TV reception. Willingly conduct some on-the-air tests to determine the actual nature and proof of interference.

Then, explain to the complainant that the problem is not in your transmitter but most probably in the TV receiver. This is the touchy point. He may have just purchased a new set, and will take it as a personal insult. Do not be condescending in your explanation. And above all, be ready and willing to give him a demonstration that your own TV set is not upset by your transmissions. This is the convincing proof. It is best if you have a portable TV set so you can show him on your own location, as well as at his home. The best demonstration would be with an older set. Once you have won the confidence of the complainant, and have proved to him that your transmitter is not at fault, you can get on to the real problem—

## TELEVISION INTERFERENCE — Continued

### THE RECEIVER

Surveys have proved conclusively that the majority (more than 90%) of TVI problems are caused by design deficiencies in the front end of the TV set. Also, over 90% of these problems can be solved by the addition of a high-pass filter at the antenna input terminals of the receiver.

TV manufacturers recognize the problem and most of them will supply the necessary filter upon request. Have the owner of the TV set write directly to the manufacturer, giving the model and serial number of the TV set, call letters of the amateur station involved and all details of interference. Usually the manufacturer will send the necessary filter with instructions, without further correspondence or fee.

If the owner prefers, suggest that he purchase a high-pass filter such as the Drake TV-300-HP or an equivalent filter. In most cases, this will solve the problem without further difficulty. In severe cases of interference, it may be necessary to install a quarter-wave stub or absorption-type trap at the antenna input terminals of the receiver.

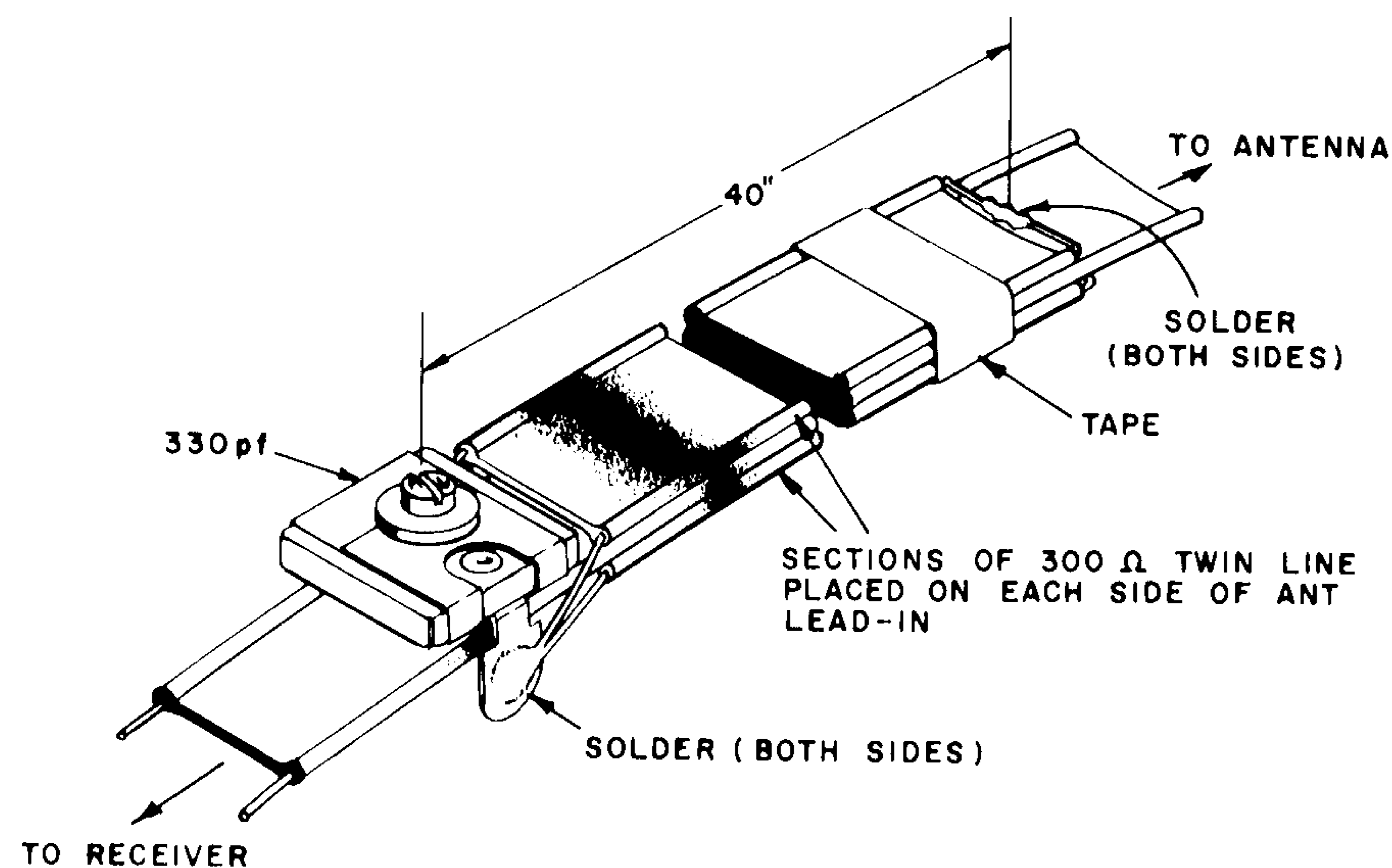

1/4-WAVE TRAP

50 mc TRAP

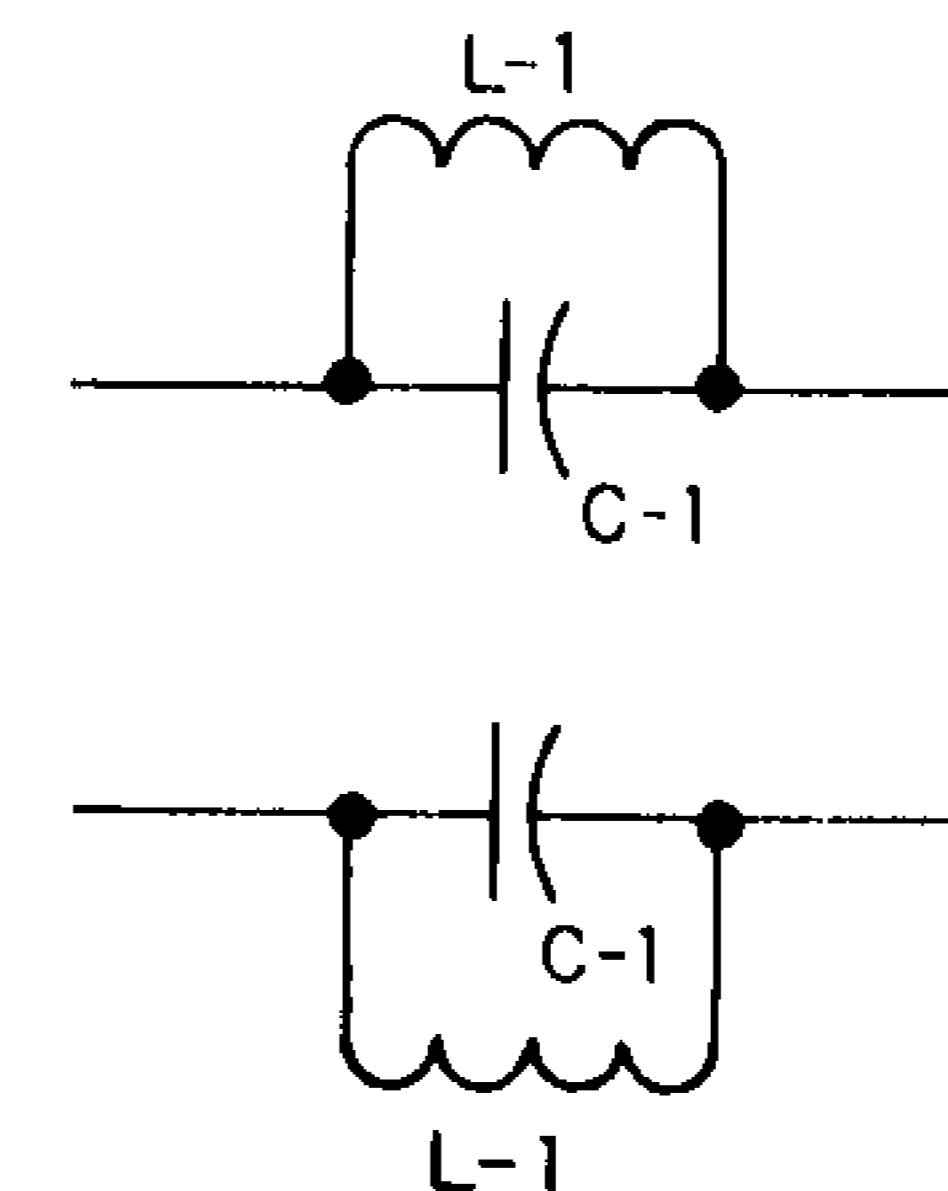

C-1-50 pf TUBULAR CERAMIC  
L-1-10 TURNS # 24 WIRE  
WOUND ON C-1

144 mc TRAP

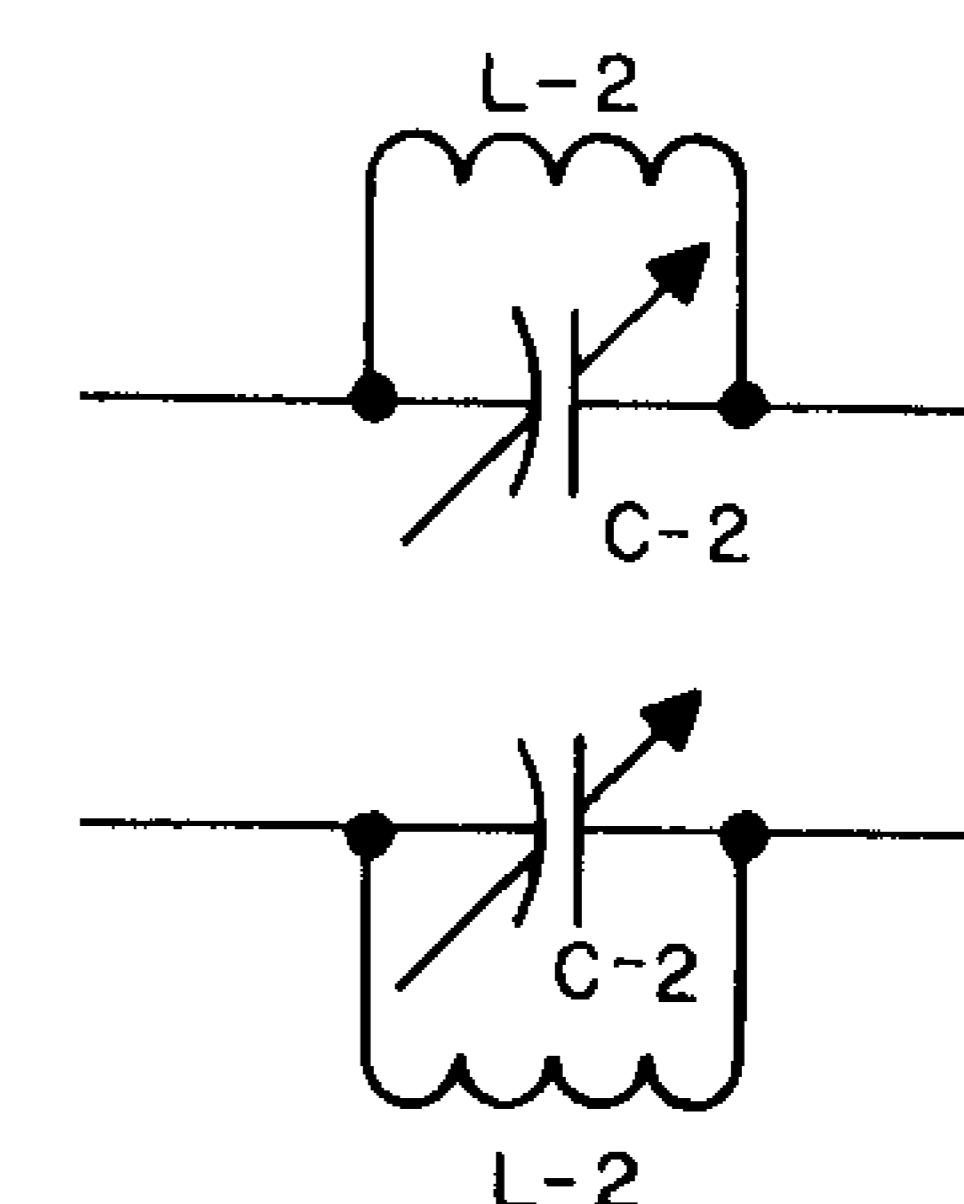

C-2 -3-12 pf NPO TRIMMER  
L-2-5 TURN # 18 WIRE  
WOUND 3/8" DIA 3/4" LONG  
TUNE C-2 TO RESONATE AT 144 mc

USE GRID DIP METER AND ADJUST  
COIL TURNS TO RESONATE AT 50 mc

### ABSORPTION TYPE TRAP

#### General Interference Information

If your TVI problem seems to be of a serious nature, or you are unable to convince the complainant of your willingness and ability to assist him, contact the local Amateur Radio Club or TVI Committee. Most centers of population have an Amateur Radio Club which has organized a TVI Committee. They will usually have some suggestions and through an organized group, may be able to solve the problem better than an individual. If there is no TVI Committee in your area, you can always contact the FCC. They normally are very willing to help and can supply considerable beneficial literature.

Occasionally, a particularly difficult TVI problem will result when a viewer is attempting to receive television signals beyond the normal service range of a TV broadcast station. In such a case, particular care must be taken with filters at the receiver. Be sure the filter is installed as close as possible to the antenna input terminals on the tuner, not just at the antenna terminals at the back of the set. It may be that a trap-type absorption filter will be required. Also, a better TV antenna can be of assistance.

Consider re-orienting the position of your 6 meter antenna. Often a TVI problem persists because of the proximity or orientation of the TV and 6 meter antennas. Raising or lowering or moving the transmitting antenna away from the receiving antenna can greatly improve the TVI condition.

Severe cases of TVI may require an AC line filter, especially if the TV set is on the same power line as your 6 meter transmitter. Use a filter such as illustrated, or a commercial line filter. Never connect the center lead of this filter directly to the chassis of a transformerless (AC-DC) set; connect it to the chassis through a 0.001  $\mu$ f mica capacitor.



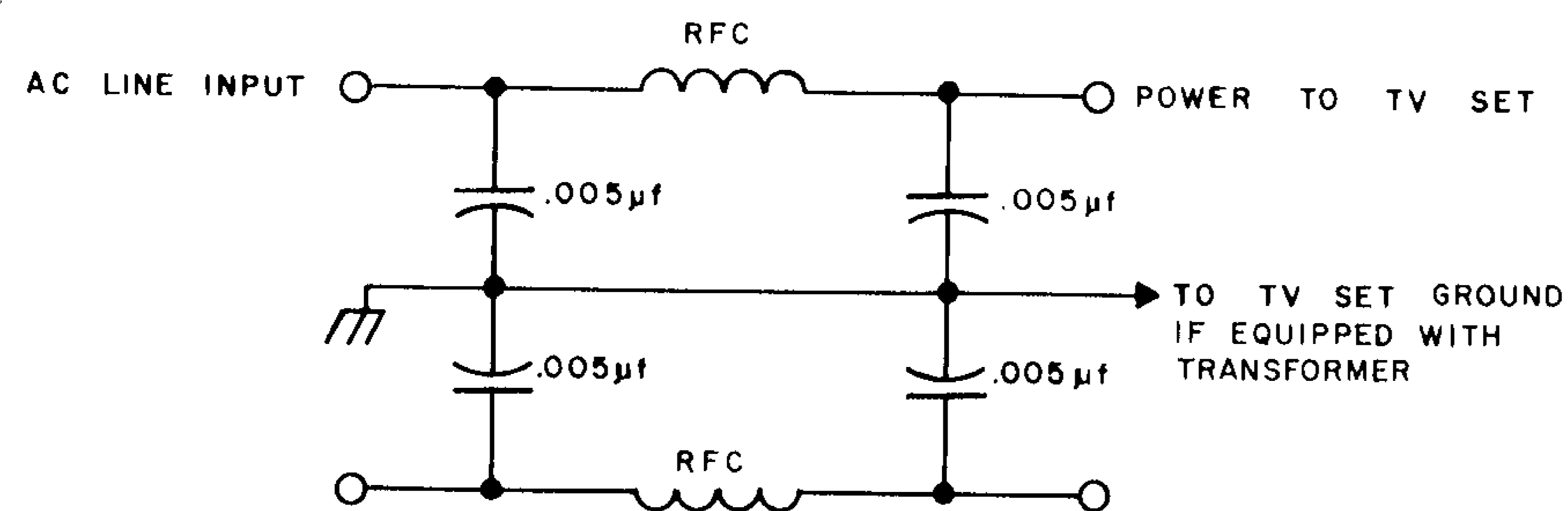

RFC-#18 ENAMELED WIRE CLOSE WOUND, 1/2" DIA. 3" LONG

### AC POWER LINE FILTER

Another source of interference can be carried in on the AC power line. An AC line filter such as illustrated can be helpful. Often, bypassing each side of the power line to chassis will be adequate. In extreme cases of line interference, check and/or replace all power supply and power line bypass capacitors. It may be necessary to bridge electrolytic bypass capacitors with a 0.001  $\mu$ f disc ceramic to act as an rf bypass.

When you install a filter (AC line or high-pass), be sure to provide a good, short electrical ground to chassis. For the high-pass filters, be sure to place the filter as close as possible to the rf input transformer. Sometimes an external ground connection to the chassis will be of further help. *Again, when the receiver is transformerless (AC-DC) do not ground the filter directly to the chassis; connect it through a 0.001  $\mu$ f mica capacitor. If you connect the chassis to an external ground, do so only through a 0.001  $\mu$ f mica capacitor.*

Interference to a high-fidelity or stereophonic amplifier is very uncommon at lower transmitter power levels, but here are a few pointers to cover this situation.

This type of interference is due to rectification of the rf signal somewhere in the amplifying circuitry. Installation of a simple R-C filter will normally cure this. Use a 47K to 100K resistor in series with the grid and a 100 pf bypass from grid to cathode. The standard grid resistor (from grid to ground) is usually in the range of 5-10 meg; it can be reduced to 2 meg. It may help to bypass the heater of this tube to chassis with a 0.001  $\mu$ f capacitor.

Be sure all components of the systems have a common chassis ground connection. Always use shielded cables for interconnecting components of the system. Also, if the speaker leads are excessive in length, it may be necessary to shield them.

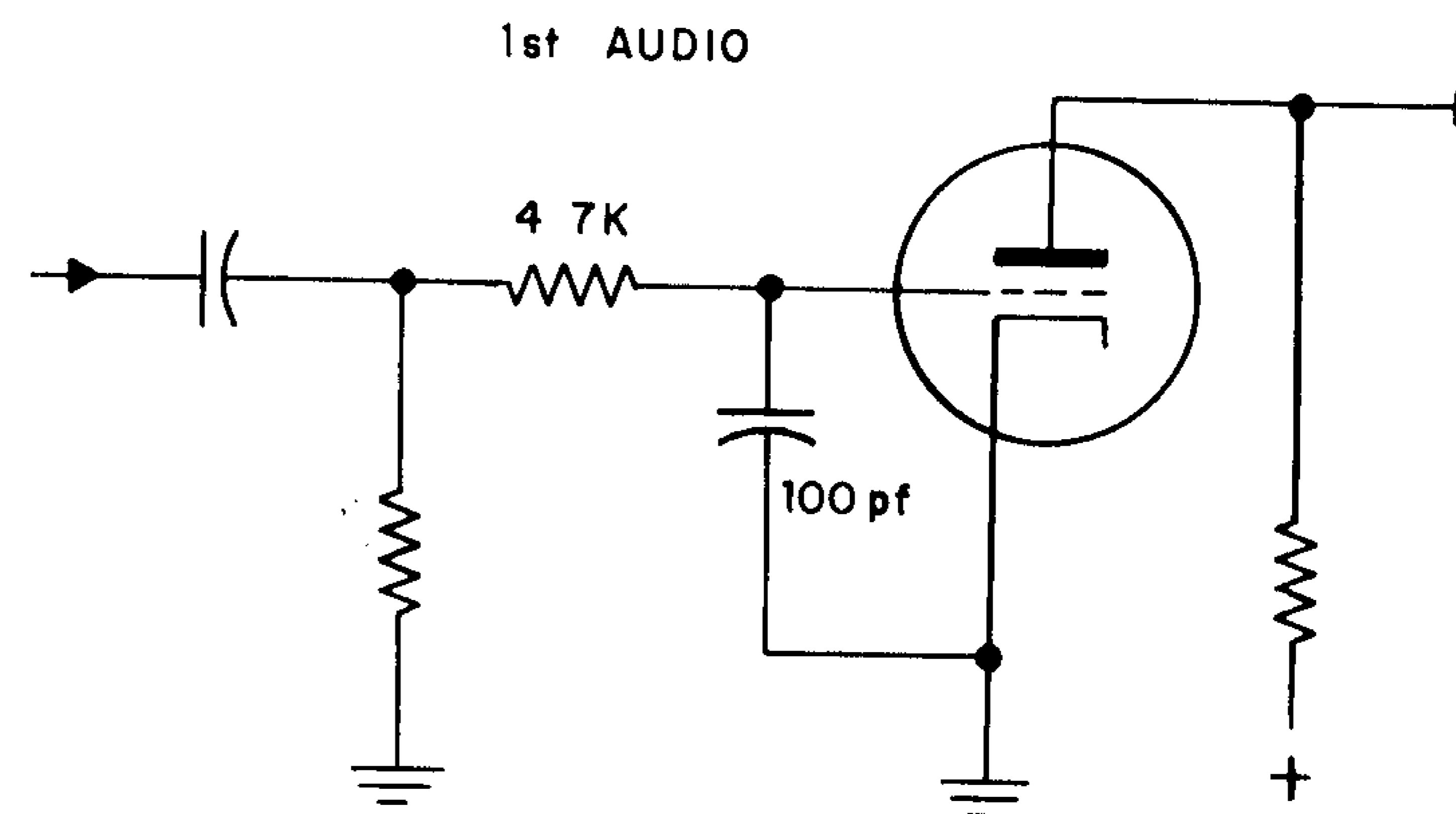

### R-C R.F. FILTER

All of these suggestions apply not only to interference caused by 6 meter transmissions. Many of these pointers apply to other forms of interference. Strong local commercial broadcasting stations can cause interference to TV sets, standard AM radios and stereo systems. Installation of the R-C filter in the first audio stage of the set will clear up most of these.



# MAINTENANCE

## ALIGNMENT

For this alignment procedure you need two VTVM's and an accurate source of RF signal (calibrated generator or crystals).

Remove the unit from the case.

Set the front panel controls as follows:

TRANSMIT-RECEIVE to RECEIVE.

SPOT to OFF.

RF GAIN to maximum.

AF GAIN to maximum.

POWER to OFF.

Set ANL switch on the back to ON.

**CAUTION:** The voltages used in this unit are at a potential high enough to be fatal. Use extreme care when working on the circuit or making adjustments while the power is on.

Turn the POWER on and let the unit warm up for at least 5 minutes.

### RECEIVER ALIGNMENT

#### IF Section

Now carefully remove the 34.4 mc crystal from its socket on the converter sub-assembly.

#### IMPORTANT NOTE

DO NOT MAKE ANY ADJUSTMENTS ON THE CONVERTER SUB-ASSEMBLY. ALL NECESSARY ADJUSTMENTS HAVE BEEN MADE AT THE FACTORY. DO NOT TOUCH ANY OF THE SLUGS.

Connect a VTVM to the AGC line (junction of R-16 and R-24).

Connect the output of the signal generator to the terminals of L-1 which have a shielded cable connected to them—ground to shield and hot lead to center conductor.

Adjust the signal generator for 1650 kc, 30% modulation with 400 cycles. Adjust the output level of the generator to maintain - 1.5 volts DC on the AGC line. The output of the generator must be kept to a level where the AGC voltage always remains 1.5 volts.

Adjust the top and bottom slugs in T-1, T-2 and T-3 for maximum audio output. Connect the second VTVM across the speaker for an accurate indication of maximum. Remember to maintain the output level of the generator to a point that results in an AGC voltage of - 1.5 volts.

Remove all test leads from the underside of the chassis. Replace the bottom cover.

Replace the 34.4 mc crystal in its socket on the converter sub-assembly.

#### RF Section

Connect the output of the signal generator to the ANT connector.

Tighten the front trimmer of C-8, tuning capacitor.

**NOTE:** In place of the signal generator, appropriate crystals can be used with the SPOT function to obtain the proper signal frequencies. Break the B+ lead to V-9 (red wire to L-4) and insert a 47K resistor in series with this lead. Now with the SPOT switch on, the output from the oscillator/tripler will be reduced sufficiently to provide a signal of proper strength. It may be necessary to vary the value of this series resistor to provide a signal of proper strength. When using the SPOT function, use the S meter for the indicating device in all the following steps. For the best results, the signal should be just strong enough to maintain a usable indication on the S meter. Thus, it would be best to use a Resistance Substitution Box for the resistor.

Loosen the set-screw on the bushing of the tuning dial. Rotate the shaft of the tuning capacitor so the plates are all the way open. Now rotate the tuning dial on the shaft so the line on the window lines up with the division marking just above 52 (mc) on the tuning dial. Position the dial as close to the front panel as possible, without rubbing, and tighten the set-screw.

- Set the receiver tuning dial to 50 mc.
  - Set the signal generator to 50 mc and the output level control for about 5  $\mu\text{V}$  output (or use an 8.33 mc crystal and the SPOT function).
  - Adjust L-2 (receiver oscillator) for maximum indication on the VTVM connected to the speaker terminals. Do not turn the slug in L-2 over one turn in either direction for this adjustment.
- NOTE: If the maximum indication in the above step can not be obtained in less than one turn in either direction, perform the following:  
 Turn the slug in L-2 until it is all the way at the top (all the way in).  
 Back the slug down into the form, **past the first peak** and adjust it to the **second peak**.  
 Proceed with the alignment.
- Set the signal generator and receiver tuning dial to 52 mc (or use an 8.666 mc crystal and the SPOT function).
  - Adjust the front trimmer on the tuning capacitor (C-8B) for maximum indication on the VTVM. Reduce the output from the signal generator to a level where the output on the VTVM remains in the same range. A signal level of about 1  $\mu\text{V}$  will give best results.
  - Repeat the last five steps as required to obtain correct calibration on the tuning dial.
  - Set the signal generator and receiver tuning dial to 51.7 mc (or use an 8.617 mc crystal and the SPOT function).
  - Adjust the rear trimmer on the tuning capacitor (C-8A) for maximum indication on the VTVM.
  - Set the signal generator and receiver tuning dial to 50.2 mc (or use an 8.367 mc crystal and the SPOT function).
  - Repeat the last three steps to assure proper tracking of the tuning dial.

IMPORTANT NOTE: Again we remind you, do not perform any adjustments on the converter sub-assembly. All necessary adjustments have been made at the factory. The following information is given for reference only: L-101 is peaked at 50.5 mc; L-102 is peaked at 51.5 mc; T-101 is peaked at 50.6 mc (with slug  $\frac{1}{8}$  to  $\frac{1}{4}$ " from top of form); L-103 is set to a point where the oscillator oscillates reliably (about  $\frac{1}{5}$  turn past the start of oscillation).

## TRANSMITTER ALIGNMENT

- Connect a dummy load or wattmeter to the ANT output connector.
- Three crystals are required for transmitter adjustments—one at the low end of the band, one in the center and the third at the upper end. Plug the low frequency crystal into socket #1, center into #2 and the upper into #3.
- Position MULT in the center of its range.
- Remove the bottom cover; turn the POWER on and let the unit warm up for a minute or more.
- Connect a VTVM to the junction of R-40 and C-48 (on T-6 doubler transformer) and the ground lead to chassis ground. Set the range to measure 0 to -70 volts DC.
- Set CRYSTAL to #2 and set TRANSMIT-RECEIVE to TRANSMIT.
- Peak L-4 (oscillator plate coil) for maximum indication on the VTVM.
- Set CRYSTAL to #1. Peak MULT and peak the bottom slug of T-6 (doubler transformer) for maximum indication on the VTVM.
- Set CRYSTAL to #3. Repeak MULT and peak the top slug of T-6 for maximum indication on the VTVM.
- Switch back and forth between #1 and #3 and readjust the coil slugs (and MULT) to provide approximately the same voltage.
- Peak LOAD and PLATE for maximum indication on the front panel meter.

This completes the alignment of the transceiver. Further alignment should not be necessary, even if tubes are replaced, with the possible exception of V-1, the 2nd mixer. If you replace this tube, you may notice a slight shift in the tracking—recheck those adjustments only (L-1, L-2 and the trimmers on the tuning capacitors).

## TROUBLE-SHOOTING INFORMATION

High-quality parts are used throughout the circuit; thus, very little service or maintenance will be required. If, however, any problem should develop, voltage and resistance charts are provided. Variations may be  $\pm 20\%$ . Most trouble-shooting should be the standard signal tracing type. This will quickly locate the stage; voltage and resistance measurements will pinpoint the problem.

The converter can be isolated from the circuit following by connecting an antenna to the primary winding of L-1. The following stage is tuneable from 15.6 to 17.6 mc. Signals in this frequency range should be received by varying the tuning capacitor. This indicates that all stages but the converter are operating normally.

### VOLTAGE CHART

		PIN								
		1	2	3	4	5	6	7	8	9
V-1	Receive	84	1.2	130	12.3 AC	6.3 AC	245	.02	0	-7.5
V-2	Receive	1.4	0	6.3 AC	12.3 AC	230	75	0	—	—
V-3	Receive	1.2	0	6 AC	12.3 AC	215	70	0	—	—
V-4	Receive	.5	.05	6 AC	0	215	0	-1.3	—	—
V-5	Receive	—	12.3 AC	360	340	—	—	6.1 AC	22	—
	Transmit	—	12.3 AC	328	303	—	—	6.1 AC	19.5	—
V-6	Receive	1.7	.65	0	0	12.3 AC	150	0	1.5	—
	Transmit	90	0	1.05	0	12.3 AC	121	0	1.35	—
V-7	Receive	66	6.1 AC	388	66	0	66	0	0	Plate 390
	Transmit	7.7	6.1 AC	153	7.7	† > -45	7.7	0	0	*318
V-8	Receive	-.9	0	12.3 AC	0	-1.8	-1.8	—	—	—
	Transmit	† > -75	0	12.3 AC	0	215	185	—	—	—
V-9	Receive	.56	0	12.3 AC	0	-1.8	-1.8	0	—	—
	Transmit	† > -15	.08	12.3 AC	0	195	190	0	—	—

Converter Sub Assembly—B+ terminal, 225 volts Receive,  
3 volts Transmit.

All voltages taken with a VTVM with respect to chassis ground.  
† Measured with a 47K isolating resistor (keep its leads to a minimum length) in series with the VTVM probe.

\*DO NOT MEASURE. You may measure B+ on the B+ side of RFC-1.

### RESISTANCE CHART

		PIN								
		1	2	3	4	5	6	7	8	9
V-1		54K*	470K	400K*	.8	.8	5.4K*	900	0	82K
V-2		2.8 meg	0	.8	.8	5.4K*	105K*	0	—	—
V-3		2.6 meg	0	2	.8	9K*	120K*	0	—	—
V-4		500K	1 meg	2	0	490K	0	500K	—	—
V-5		NC	.8	450*	1.25K*	470K	NC	.8	330	—
V-6		∞	330K	4.7K	0	.8	230K*	320K**	3.3K	4.8
V-7		NS	.8	50K*	NS	24K	NS	0	0	Plate 650*
V-8		82K	0	.8	0	∞*	∞*	82K	—	—
V-9		47K	12	.8	0	∞*	∞*	0	—	—

NC—no connection

NS—not significant

\*—with respect to junction of CR-2 and C-58.

\*\*—will vary with setting of MIC GAIN control.

Resistance readings taken with a VTVM with respect to chassis ground.

Controls set as follows:

ANL—ON

TRANSMIT-RECEIVE in RECEIVE

POWER OFF

SPOT OFF

RF and AF GAIN in maximum counterclockwise position

### FRONT

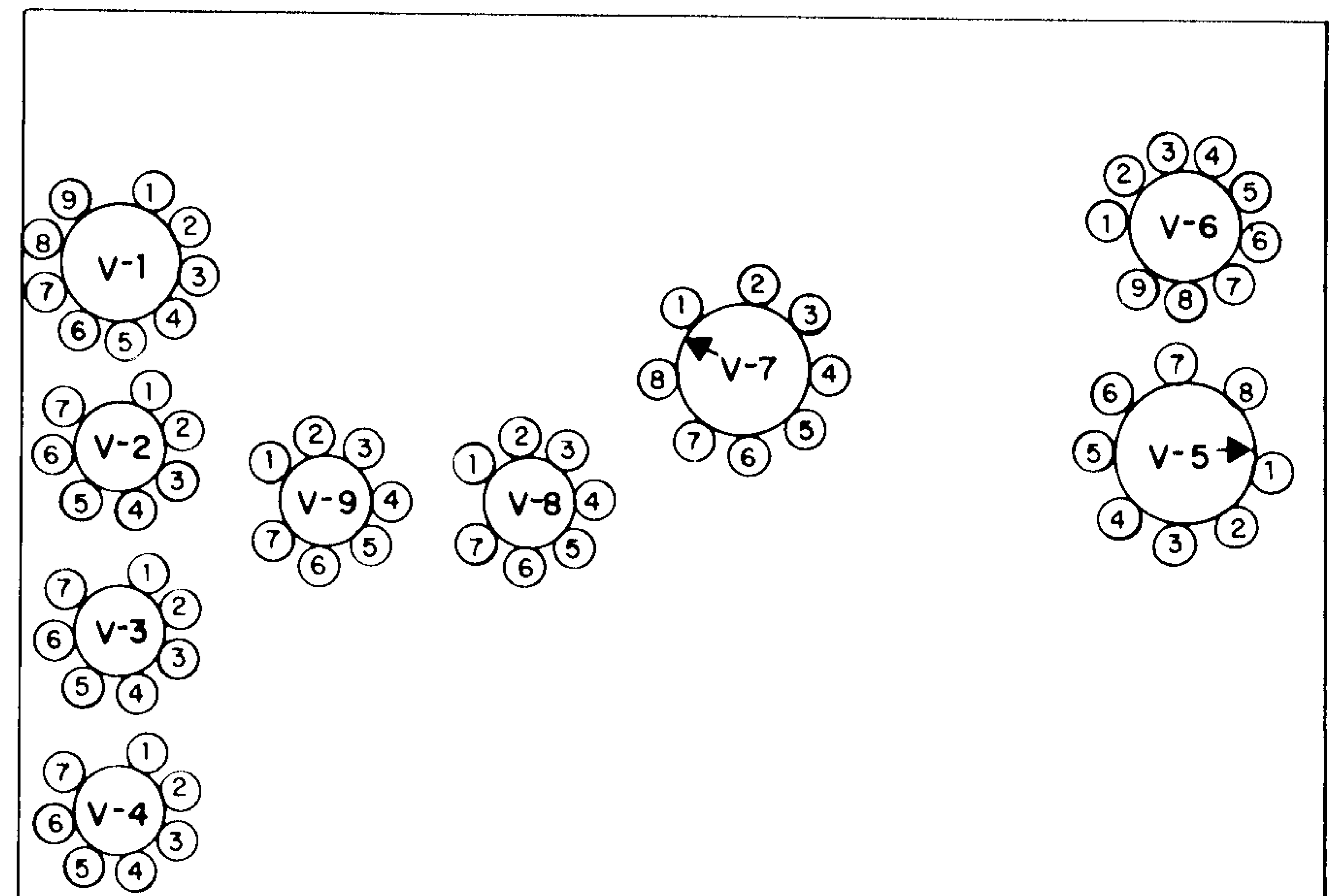

### TUBE LOCATION (bottom view)

## CIRCUIT DESCRIPTION

The following description of circuit function is given to add to your knowledge of your transceiver. It will also help you maintain and service it.

### RECEIVER SECTION

The most critical portion of the transceiver is the "front end" or converter. This section has been carefully prewired and aligned to assure that maximum benefit is obtained from the carefully designed circuitry.

#### Converter

The input signal, at a frequency of 50 to 52 mc, is amplified by V-101. In V-102A it is mixed with the signal generated by the 1st Oscillator V-102B, which operates at 34.4 mc. The resulting frequency is in the range of 15.6 to 17.6 mc. This is what appears at the output of the converter.

L-101 is the RF Input coil and matches the antenna impedance (30-90 ohms) to the input impedance of the RF Amplifier, V-101. V-101, a nuvistor, is operated as a neutralized triode. The nuvistor assures minimum internal noise, and the standard triode amplifier arrangement provides the required gain. The combination of C-101 and C-103 form the bridge neutralizing circuit. The plate circuit is tuned to resonance by L-102.

The triode section of V-102 is used for the crystal-controlled 1st Oscillator. The crystal is a 3rd overtone type, cut to exactly 34.4 mc. The circuit is a standard tuned-plate, tuned-grid oscillator. The plate circuit is peaked for resonance by the combination of L-103 and C-112.

The pentode section of V-102 is used for the first mixer. The signal from the RF amplifier is fed directly into the grid through C-106. The oscillator signal is coupled into this section by inter-electrode capacity in the tube.

The plate circuit of the 1st Mixer is tuned to the **difference** between the incoming frequency and the frequency of the crystal oscillator. Thus, it is tuned to the range of 15.6 to 17.6 mc. T-101 not only serves the purpose of resonating to the difference frequency, but it also matches the output impedance of the Mixer to a low-impedance output circuit.

This low output impedance circuit is used to feed the 1st LF. to the 2nd Mixer without adverse loading effects, interaction and keeps radiation to a minimum. All of these things are important to maintain complete isolation of the converter circuit from the circuitry following.

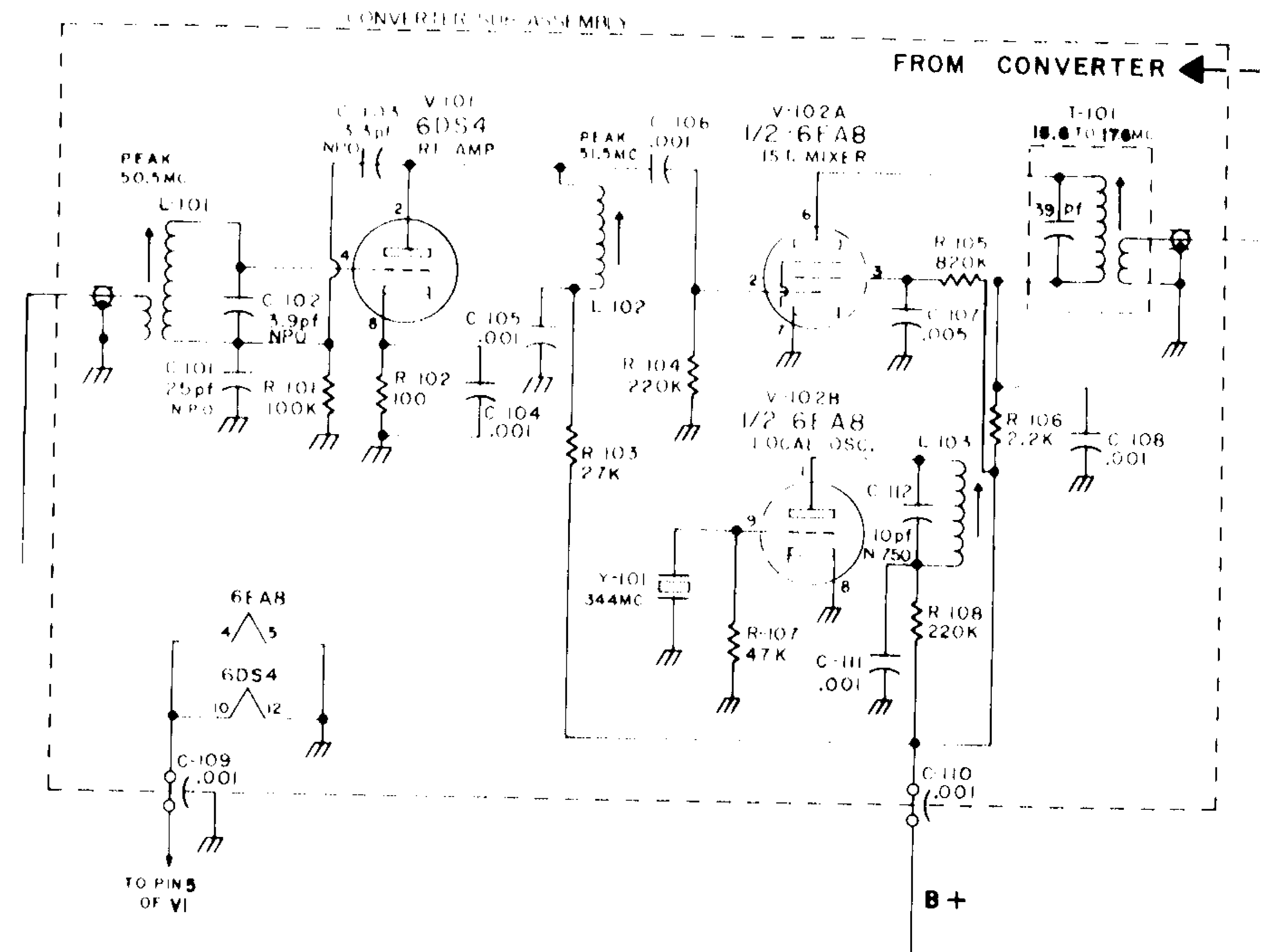

You will notice that the power for the converter is fed through .001  $\mu$ f feed-through capacitors. These provide adequate RF isolation for the power circuits. It keeps the R.F. signals inside the converter from feeding back into the power supply and thus into other circuits, and it also keeps out other R.F. frequencies that might be radiated from nearby wiring. Thus, the entire converter assembly is effectively shielded from all external signals. The input is a shielded cable and the output is a shielded cable.

Another item should be noted here. The converter has a 2 mc band-pass. This is achieved through careful design and properly peaked resonant circuits. Each coil must be peaked at the frequency noted to maintain the broad-band characteristics.



**2nd Mixer and Oscillator**

The output from the converter sub-assembly is fed through a low-impedance circuit (a shielded cable) to the primary winding of the 2nd Mixer input coil, L-1. This coil matches the low-impedance feed line with the high impedance of the grid circuit of V-1.

The resonant frequency of this circuit is varied with one section of the tuning capacitor. This tuned circuit feeds the grid of V-1A, the 2nd Mixer.

The triode section of V-1 is used for the 2nd Oscillator, which is the tuneable oscillator. The combination of L-2 and the tuning capacitor C-8B with its associated trimmer, forms the resonant circuit for the oscillator. The circuit is a shunt-fed Hartley oscillator. Adequate temperature compensation is provided by C-33. The output of the oscillator is coupled to the mixer circuit by inter-electrode capacitance in the tube. The oscillator operates on the low side of the incoming frequency.

The RF GAIN control is in the cathode circuit of the 2nd Mixer. It controls the gain of the 2nd Mixer.

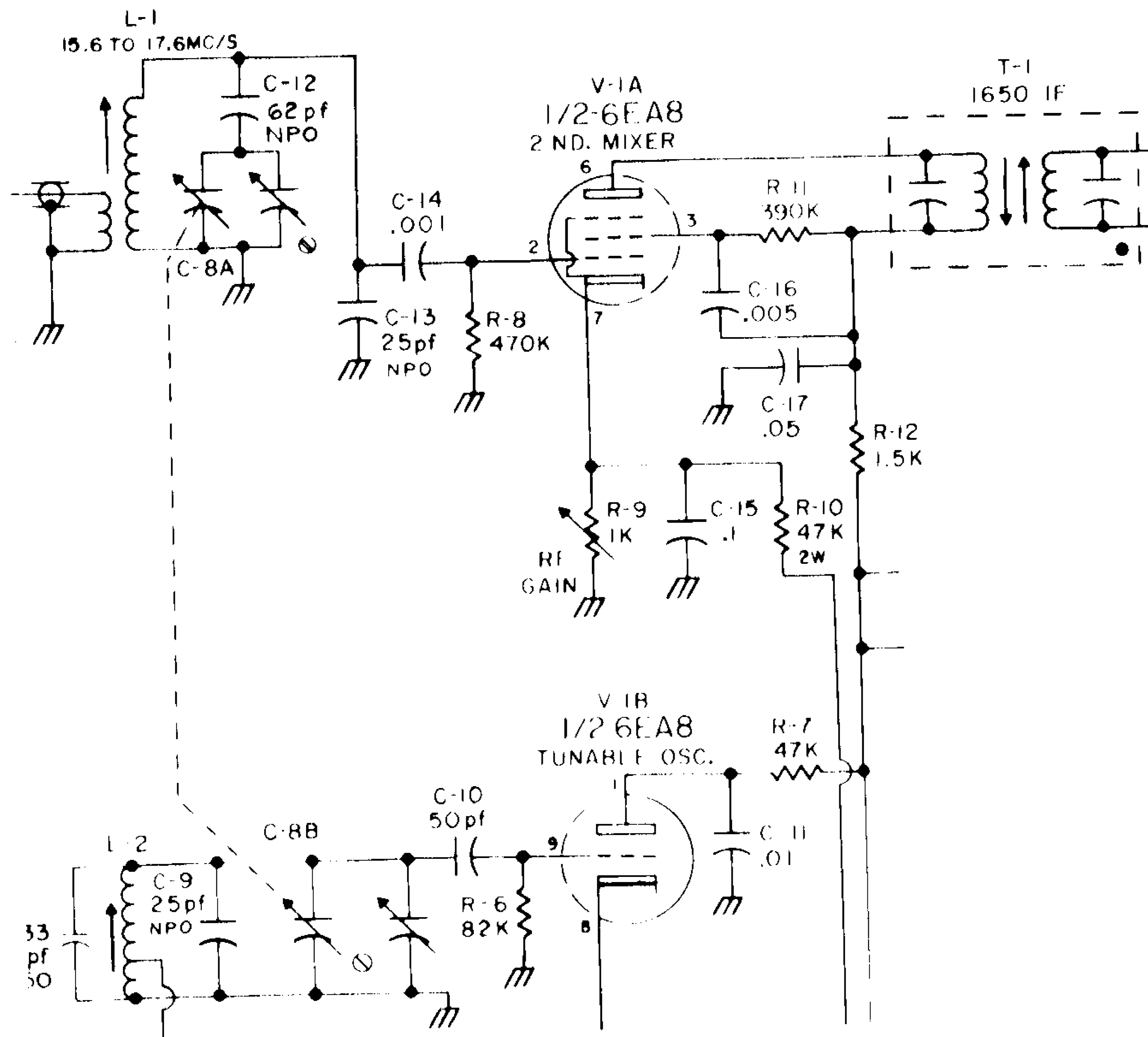

**I.F. Amplifier**

T-1, the 1st I.F. transformer is tuned to the difference frequency of the tuneable oscillator and the incoming signal, 1650 kc. The Intermediate Frequency amplifying system is composed of three double-tuned circuits, T-1, T-2 and T-3 and two high-gain tubes, V-2 and V-3. The 6BZ6 is a semi-remote cut-off tube to allow complete AGC control of the signal. These two stages are the only ones controlled by the AGC voltage developed at the detector.

The 6BZ6 tube is a high-gain tube, which provides more than adequate gain for the I.F. stages. The three double-tuned I.F. transformers assure narrow bandwidth.

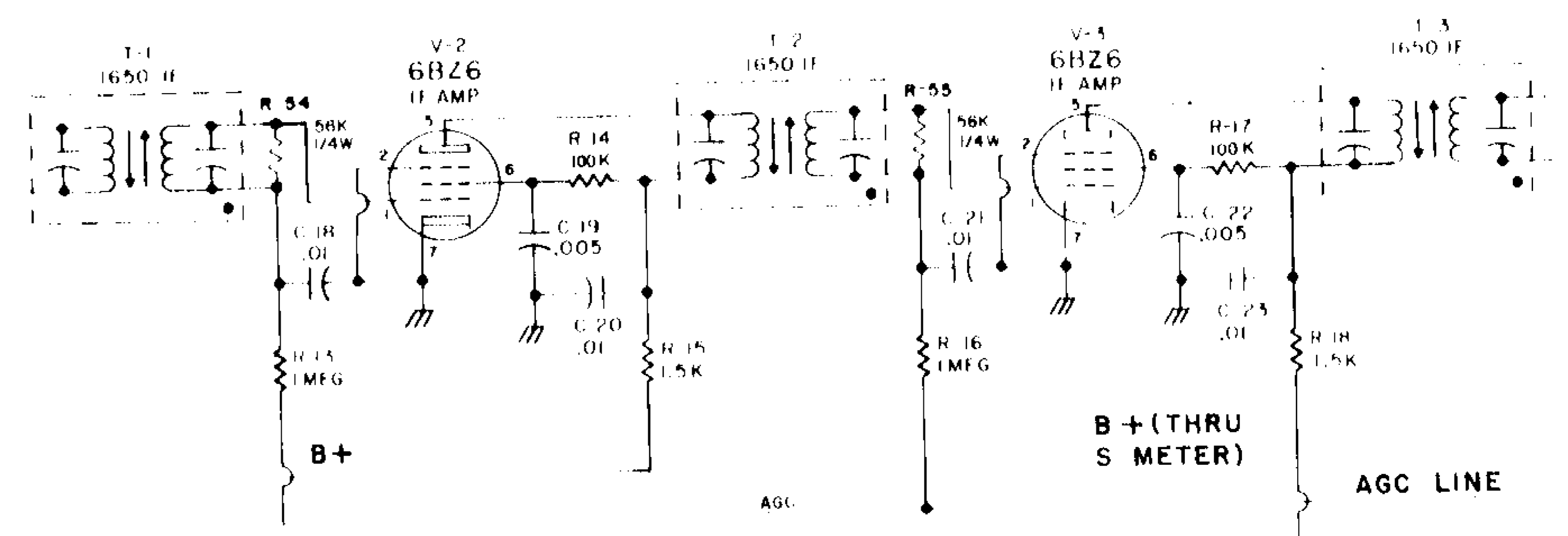



## Detector and Automatic Noise Limiter

The dual-diode, V-4, a 6AL5, is a high-perveance tube, which makes it particularly sensitive to low-level signals and contributes to the high-efficiency of the Detector and Automatic Noise Limiter circuits. The first section of this tube functions as a standard audio detector. The Automatic Gain Control voltage is taken from this section, filtered and fed back to the control grids of the I.F. amplifier tubes, V-2 and V-3.

The second section of V-4 is used for a highly-efficient series-gate noise limiter. There are two primary advantages to this circuit:

1. It introduces negligible distortion even with high signal levels and high percentages of modulation. This is a shortcoming of many noise limiters; that is, most noise limiters distort the desired signal when the limiting action begins.
2. The reason for the low distortion is the self-adjusting feature of this circuit. It is self-compensating over a wide range of signal levels. That is, as the amplitude of the incoming signal varies, the clipping or limiting level varies.

The output from the Detector/ANL circuit is taken from pin 2, and coupled to the AF GAIN control. The setting of this control determines the audio voltage fed to the AF Amplifier and Modulator stages.

## Audio Amplifier and Modulator

$\frac{1}{2}$  of V-6, a dual-triode, is used for low-level audio frequency amplification. You will notice that double by-pass capacitors are used for the cathode resistor of all the audio stages and the final RF Amplifier. The large value is for audio by-passing. However, large capacitors typically exhibit inductive-reactance at RF frequencies. Thus, it is necessary to provide RF by-passing with a ceramic disc capacitor.

The remaining  $\frac{1}{2}$  of V-6 is used for the microphone pre-amplifier; it is used only in the Transmit function. The 1000 pf disc capacitor in the grid circuit rolls off the high frequency response of the microphone. Output from this amplifying stage is coupled to the MIC GAIN control, which controls the amplitude of the microphone signal passed on to the Audio Frequency Amplifier, V-6A.

The audio Power Amplifier/Modulator stage utilizes a rugged 6L6GC tube. This is a tube with plenty of reserve power capabilities. It is a sensitive, high-gain tube with more than enough power to completely modulate the 2E26 R.F. Power Amplifier.

One of the secondary windings of T-5, the Output/Modulation transformer, is used to drive the speaker. A front panel jack provides for headphone operation, or an external speaker.

The 390 pf capacitor in the grid circuit of V-5, provides high frequency roll-off, thus limiting the frequency response to the standard 300 to 3000 cps required for maximum intelligibility. The 0.001  $\mu$ f, 2KV disc capacitor in the plate circuit of V-5 is primarily for protection of the modulation transformer against voltage spikes. When switching from Receive to Transmit, voltage spikes can be created and amplified through the Audio amplifying stages to a level that could damage the transformer. This capacitor charges-up on the spikes, thus protecting the transformer.

The bias point, plate and screen voltage, and modulation transformer impedance have all been carefully designed to permit the Modulator stage to clip slightly when the plate voltage swings into the negative half-cycle. This soft-clipping prevents distortion due to over-modulation in the negative direction. This permits the positive half-cycle to swing up to full + modulation, without distortion on an equal amplitude negative swing. This results in greater modulation efficiency.

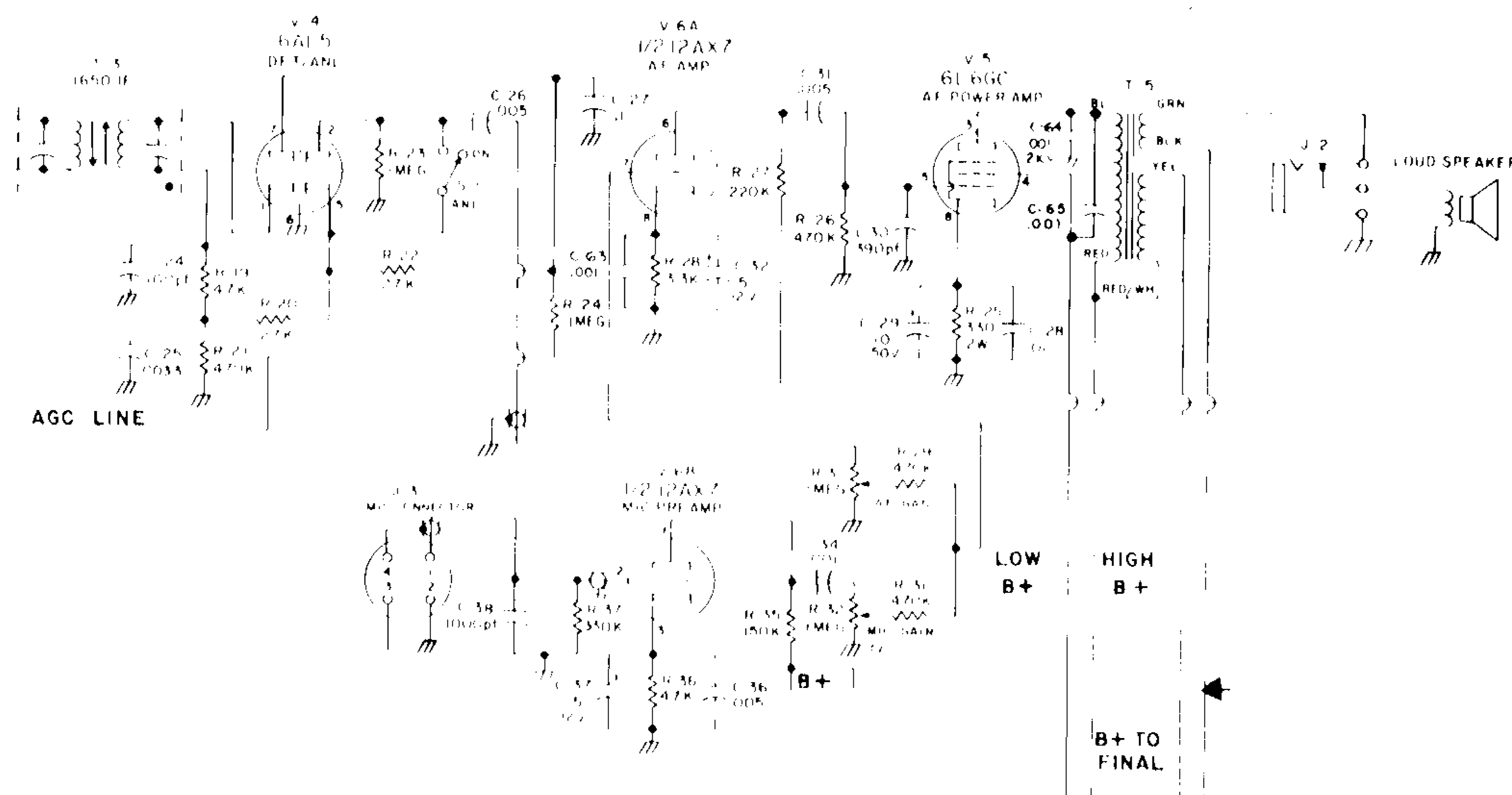

## TRANSMITTER SECTION

RF energy is developed in the grid circuit of the Oscillator/Tripler, V-9. This stage is operated as a Colpitts oscillator with the plate circuit tuned to the third harmonic of the grid circuit. The capacitive divider network is composed of a combination of the capacity of the shielded cables connected to the Crystal/VFO selector switch and C-55 and C-56. The screen grid of V-9 is used for the "plate" of the oscillator circuit. The plate circuit is tuned to the third harmonic of the oscillator frequency. The resonant point of this circuit is controlled by the setting of C-53, the front panel MULT control.

There are two advantages to this pentode oscillator/multiplier circuit.

1. The separate loads for the circuits (screen for the oscillator and plate for the tripler), provides isolation, for the oscillator, from the effects of changes in loading. Thus, the oscillator is more stable in frequency and reliability.
2. The isolation and separate tuned circuits prevents the crystal from oscillating in any but the intended mode.

With VFO operation, the pentode function (that is, screen grid isolation) of this circuit provides additional buffer action for the VFO. This makes the VFO practically immune from any voltage or load changes in the transceiver.

The next stage is the doubler; which uses a 12AQ5 tube. This beam power pentode tube was chosen to provide adequate power to drive the 2E26 R.F. Amplifier to its full capabilities. Grid-leak bias is developed across R-42, and is present only when grid drive is present.

Note that the doubling is done in a separate tube. Often, the doubling function is performed in the final stage (at the expense of efficiency). The separate doubler tube provides extra isolation, drive and minimum harmonic problems.

The plate circuit of the doubler stage is tuned to the 50 mc range. The inductive-coupled double-tuned circuit provides maximum efficiency. It also eliminates the possibility of harmonics being coupled into the final amplifier.

The 2E26 is a compact, high-efficiency, medium-power, beam power pentode. It is particularly suited for VHF use up to 150 mc. Because of the metal base shield, neutralization is not required even when operated as a straight-through amplifier at these frequencies.

Operating bias for this tube is a combination of grid-leak and protective cathode self-bias. The cathode bias developed is sufficient to protect the tube from damage if grid drive is lost.

The output circuit is the popular Pi matching network. Because it is basically an inductive coupling, it inherently suppresses harmonic radiation (inductive reactance varies **directly** with frequency—the higher the frequency, for example, harmonics, the greater the inductive reactance). It also is a simpler form of output tuning.

The transmitter section is broad-banded to simplify tune-up and operating frequency changes. This is achieved with the double-tuned T-6 coupling transformer. T-6 is stagger-tuned for broad band-width characteristics.

Throughout the design of the transmitter, very careful consideration was given to the elimination of harmonic generation, coupling and radiation. Any one of these could cause TVI problems. Some of the features that help to eliminate any such problems are:

1. Electron coupling in V-9, the Oscillator/Tripler. This provides a buffer for the oscillator circuit.
2. A tuned circuit is used in the plate circuit of V-9. This resonant circuit provides added suppression of harmonics.
3. The **separate** doubler stage provides isolation and buffer action.
4. Double-tuned, inductive coupling for drive from the doubler to the final, assures harmonic reduction and adequate drive over the desired frequency spread.
5. Straight-through final amplifier maintains minimum harmonic problems, while achieving maximum efficiency.
6. Pi network output circuit furnishes proper matching, harmonic suppression and maximum efficiency.
7. The entire circuitry is completely shielded. Tube shields are used for all tubes and the entire unit is shielded with the wrap-around case.

### Spot Function

The SPOT switch disables the Doubler and Final stages and turns on the VFO and Oscillator/Tripler by completing the necessary ground and B+ circuits. Thus, the VFO and/or the Oscillator/Tripler can be functional while the receive section is operating. Output from these stages is at a sufficient level to radiate into the receiver front-end. This permits you to pin-point your transmitting frequency on the receiver dial.

### METER CIRCUIT

The S Meter is placed in a bridge circuit and current through the 2nd I.F. Amplifier is used for the variable arm. The S Meter adjustment is set to compensate for normal current drain in V-3. As the incoming signal varies in strength, the 6AL5 Detector tube develops an AGC voltage that varies in strength. This is applied to the control grids of the I.F. Amplifier tubes. The effect on the plate and screen current of V-3 is registered on the S Meter; thus giving an indication of the strength of the incoming signal.

In the function as a relative power meter, the B+ voltage is removed from the circuit of the meter, and the circuit becomes a simple peak-reading RF voltmeter. The diode rectifies the RF voltage taken from across the Antenna output connector and capacitors are provided to filter the resultant voltage. Thus, the meter is reading the voltage applied across the output load, which is a direct indication of the power being fed to the load (which in actual operation is the antenna).

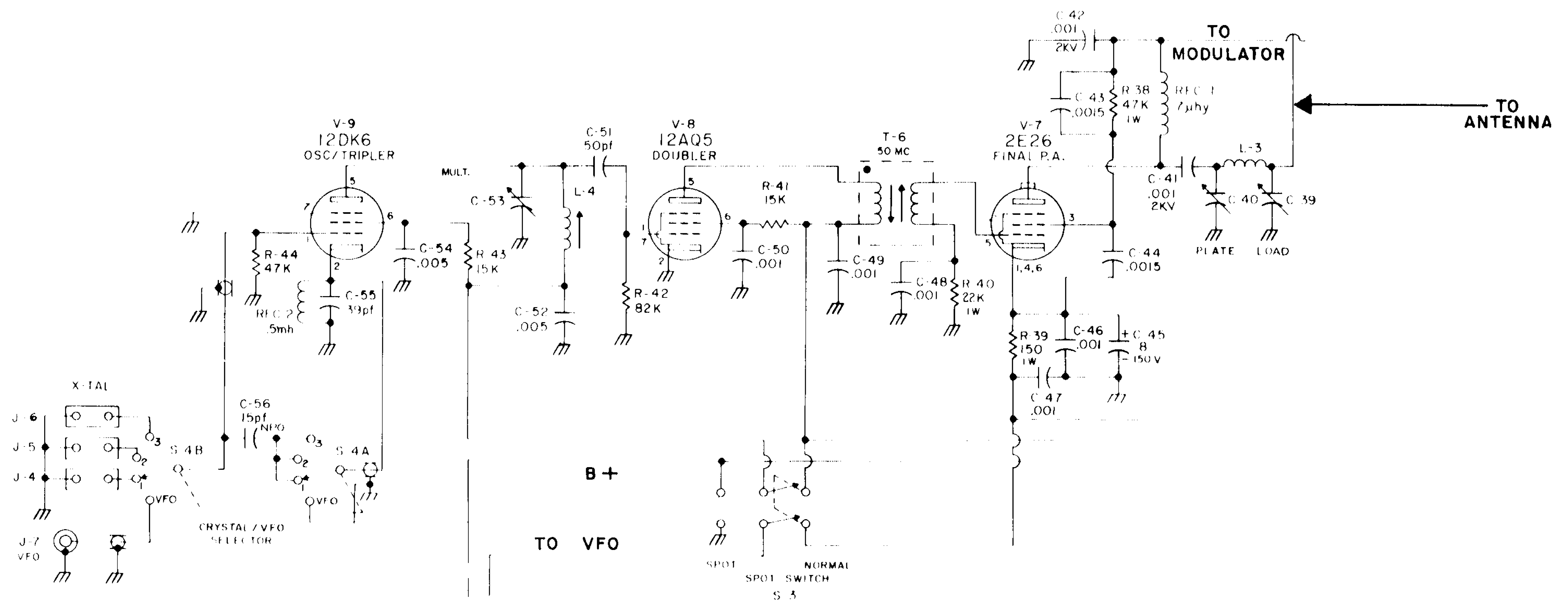

**POWER SUPPLY**

For operation from a 12-volt DC source, the power supply uses two transistors and a special transformer, the circuit functioning as an inverter. The transistors are used as "switches" and serve the same function as the mechanical vibrator used in many older DC inverter circuits. The transformer windings in the base circuits are the feed-back windings. The Blue-Brown-Yellow windings are connected to the collectors of the transistors and serve as the primary windings. The entire circuit operates at a switching rate of approximately 90 cycles.

For AC operation, the transformer functions as a normal step-up type to provide the required voltage to the secondary.

Two power cables, with appropriately wired connectors, determine the proper transformer and circuit connections. Separate fuses are provided for AC and DC operation. Filament wiring is in series-parallel combination to provide proper current drain at the 12.6 volt level. You will notice that filament by-passing is utilized at critical circuit points.

True push-to-talk operation is achieved with the front panel Transmit/Receive switch. Thus, the microphone switch can be used to operate the transmit-receive function, or the front panel switch can be used. If a microphone other than the one included with the unit is to be used, both push-to-talk circuit features are still operational. The relay contacts switch the critical circuit points; the microphone button and Transmit/Receive switch only complete the circuit for the relay coil.

Notice that there is a shorting switch contact across the microphone element when the microphone button is in the normal position. Thus, you can operate the front panel T/R switch for tune-up purposes without fear of pick-up from the microphone. This also points out the fact that for transmission, the T/R switch cannot be used by itself, unless the mic switch is defeated in this shorting function. That is, you must press the mic button to allow the crystal element to become active and functional.

We call your attention to the liberal use of decoupling and by-passing throughout the circuit. This prevents any coupling back through the power supply circuits. All critical points are more than adequately by-passed and isolated from other circuits.

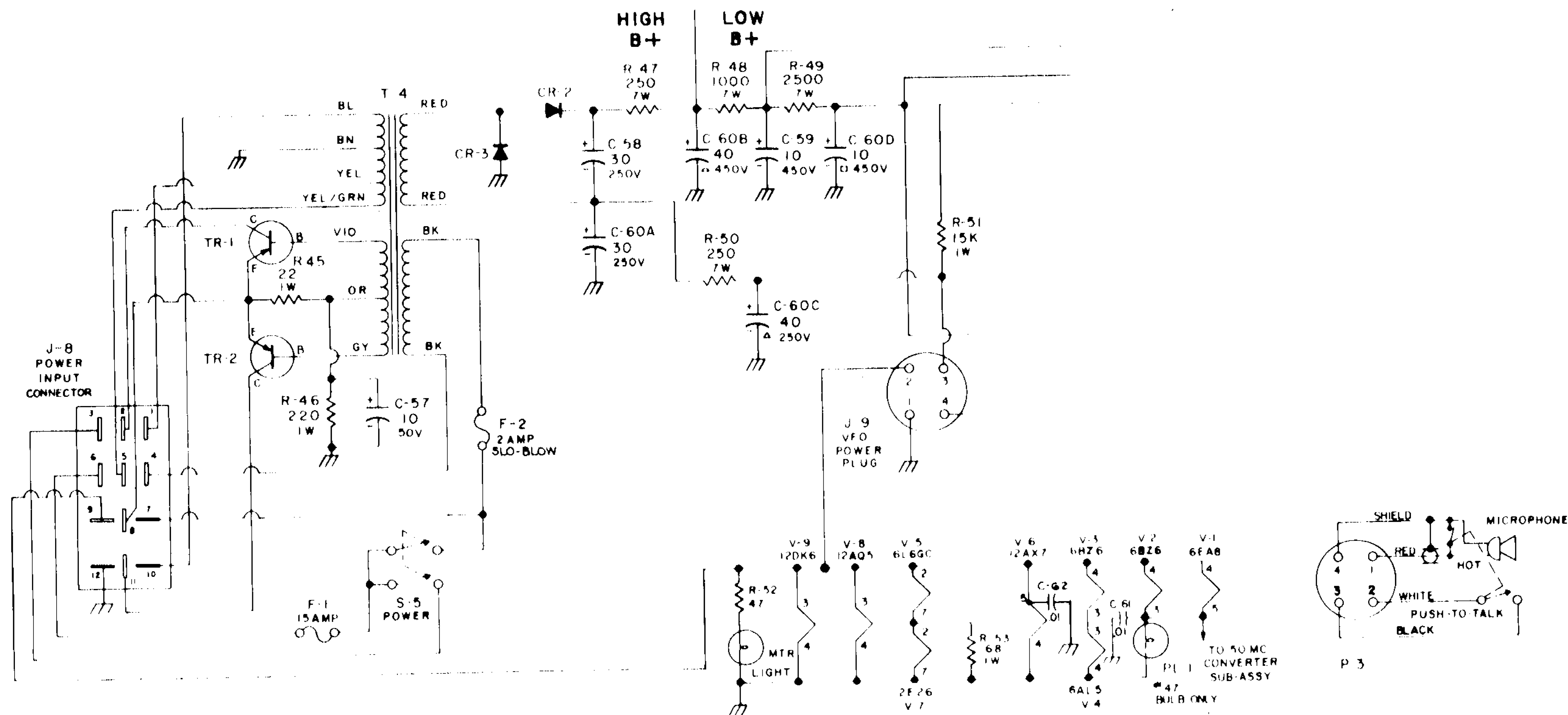

# NOTES

## PHONETICS

ADAM	GEORGE	MARY	SUSAN	
BAKER	HENRY	NANCY	THOMAS	YOUNG
CHARLIE	IDA	OTTO	UNION	ZEBRA
DAVID	JOHN	PETER	VICTOR	
EDWARD	KING	QUEEN	WILLIAM	
FRANK	LEWIS	ROBERT	X-RAY	

## COMMON Q SIGNALS

QRM	Interference	QSO	Contact or communication
QRN	Static	QSY	Change in operating frequency
QRZ	Who is calling?	QTH	Location
QSB	Fading	QTR	Time
QSL	Acknowledge contact or receipt (usually a card).		



## **KNIGHT WARRANTY**

Your Knight equipment is warranted to be free from defects for a period of one year under normal use. Any defective parts will be repaired or replaced free of charge during the first ninety days from date of sale. After ninety days, and for the balance of the year, we will replace any defective parts, charging only for labor. Returned equipment must be shipped prepaid.

## **IMPORTANT INSTRUCTIONS**

If your unit is not operating properly, first write to our Technical Consulting Service for assistance.

Authorization must be obtained before returning your equipment for service. After you receive your return authorization, please pack your unit in a sturdy shipping carton and tightly cushion with plenty of packing material to avoid costly damage in transit. Send the package prepaid and fully insured to the address at the bottom of this page. Mark the package: **FRAGILE--DELICATE ELECTRONIC EQUIPMENT.**

## **OUT OF WARRANTY SERVICE**

Knight maintains parts and complete service facilities for all its products. All parts are available; you may order by description (and part number if known). If service is required, follow the instructions given above. Repair charges will be for time and materials used.

**ADDRESS CORRESPONDENCE AND RETURNED EQUIPMENT TO:**

**KNIGHT ELECTRONICS CORP.**

**Knight Service Department**

**2100 Maywood Drive • Maywood, Illinois 60154**