



INTRODUCTION

The Atlas 180 Transceiver is designed for single sideband and CW communications in the 20, 40, 80 and 160 meter amateur radio bands. It employs all solid-state circuitry, with modular construction. Its conservative 180 Watt power input rating will provide world-wide communications from fixed, portable or mobile installations.

Atlas Radio Inc. is licensed by Southcom International, Inc. of Escondido Calif., manufacturers of military and commercial radio equipment. With this agreement Atlas Radio is able to bring the most advanced, state-of-the-art circuit designs to the amateur radio market. Les Earnshaw, founder and director of R & D at Southcom is considered to be one the foremost solid state engineers in the world, effectively proven by the rapid growth of Southcom International in the military and commercial markets of the United States as well as many other countries.

The high performance and reliability of the Atlas 180 is enhanced by the finest craftsmanship, and a most thorough quality control program. Our staff is made up of highly skilled assembly workers, technicians and engineers, many of whom are radio hams. Our service department if and when needed, is dedicated to making every Atlas owner a satisfied customer. Speaking for all the gang at Atlas Radio, we wish you many hours of operating pleasure with your atlas 180.

73 Herb Johnson W6QKI
Pres., Atlas Radio, Inc.

TABLE OF CONTENTS

Technical Specifications.....	2,3
Block Diagram.....	3
Special Circuit Features.....	4
Photos, Top-Bottom-Rear Views	6,7
Mobile Installation.....	8
AC Power Supply Console....	8
Linear Amplifier Connections	9

Operation.....	9,10
Antennas, Impedance Matching	11
Antennas, Mobile.....	12
PC-100, PC-200 Schematics...	13
PC-300, PC-500 Schematics	14
PC-400, PC-600 Schematics	15
PC-800, PC-900 Schematics	16
Voltage Chart...	Inside Rear Cover
Chassis Schematic...	Insert

GENERAL SPECIFICATIONS

BAND COVERAGE: 20, 40, 80 and 160 meters.

FREQUENCY RANGES: 1800-2000, 3500-3850, 3700-4050, 7000-7350, 14,000-14,350 kc.

FREQUENCY CONTROL: highly stable VFO common to both receive and transmit modes. Tuning dial calibrated in 5 kc increments with easy interpolation to 1kc. Tuuning rate: 15 kc per revolution of the tuning knob.

EXTERNAL FREQUENCY CONTROL: Rear socket provides for plug-in of external VFO or crystal oscillator accessory for separate control of transmit and receive frequencies or for networkand MARS operation.

CIRCUIT DESIGN: All solid state, 4 I.C.s, 18 transistors, 32 diodes. Single conversion, 5520 kc I.F.

MODES OF OPERATION: SSB: lower sideband on 40, 80, and 160 meters, upper sideband on 20 meters with SB selector switch in NORM. position. Opposite with switch in OPP. Position. CW: offset frequency in transmit mode.

MODULAR CONSTRUCTION: Includes plug-in circuit boards for ease of maintenance.

PLUG-IN DESIGN: Transceiver plugs into deluxe mobile bracket, or into the AC power supply console, making transfer or removal a simple operation. All connectors are standard: SO-239 antenna jack, ¼ in. phone jacks for Mic., CW key, external speaker or headphones, and linear amplifier control.

POWER SUPPLY REQUIREMENTS: operates directly from 12 to 14 volt D.C. source with negative ground, (standard automotive system). Current drain is 300 to 500 ma. in receive mode, 16 amps peak in transmit mode. Atals models AR-117 and AR-230 power supply consoles are available for AC operation.

FRONT CONTROLS: Tuning Dial, Dial Set, Function Switch, Band Switch, A.F. Gain, R.F. Gain, Mic. Gain, Sideband Selector, Calibrator On-Off, Dial Light Dimmer.

FINISH: black vinyl covered steel cabinet, anodized aluminum panel.

RECEIVER SPECIFICATIONS

CIRCUIT DESIGN: Front end design provides exceptional immunity to overload and cross modulation, matching or out performing the best vacuum tube designs. Signals are converted directly to the 5520 kc I.F. without preamplification. Converter and product detector are double balanced diode rings. I.C.s are employed in the I.F. and A.F. stages.

SENSITIVITY: Requires less than 0.3 microvolts for a 10 db signal-plus-noise to noise ratio. (typically 0.2 microvolts)

SELECTIVITY: Crystal ladder filter, 8 poles. Bandwidths: 2.7 kc @ 6 db, 4.3 kc @ 60 db, 9.2 kc @ 120 db !! Ultimate rejection more than 120 db !! Shape factor: 1.6

IMAGE REJECTION: More than 60 db.

INTERNAL SPURIOUS: Less than equivalent 1 microvolt signal.

AGC CHARACTERISTICS: Audio output constant within 4 db with signal variation from 5 microvolts to more than 3 volts.

OVERALL GAIN: Requires less than 1 microvolt signal for 0.5 watts audio output. (CW carrier, 1000 cycle heterodyne)

AUDIO FIDELITY: 300 to 3000 cycles, plus or minus 3 db.

AUDIO POWER: 2 watts to a 3 ohm speaker with less than 10% distortion.

INTERNAL SPEAKER: 3 inch, 3 ohm, 0.68 oz. Magnet. Rear jack permits plug-in of external speaker, or high impedance headphones. When transceiver is plugged in to the AC power supply console, internal speaker is disconnected automatically, and front facing speaker on console becomes operative.

METER: Reads S units from 1 to 9, plus 10 to 50 db.

CALIBRATOR: Provides 100 kc check points for accurate dial setting.

DIMENSIONS: 9 ½ in. (24.1 cm) wide, 3 ½ in. (8.9 cm) high, 9 ½ in. (24.1 cm) deep, overall.
Weight: 7 ½ lbs. (3.4 kg) net. 9 lbs (4.1 kg) shipping weight.

TRANSMITTER SPECIFICATIONS

CIRCUIT DESIGN: Broadband design eliminates transmitter tuning. Single conversion from I.F. to output frequency produces minimum spurious and mixing products. 2 section low-pass filters on each band provide harmonic suppression equal to commercial standards. Includes ALC and infinite SWR protection.

FREQUENCY CONTROL: Internal VFO automatically transmits on exactly the same frequency that is being received. Rear socket provides for plug-in of external VFO or crystal oscillator accessory for separate control of transmit and receive frequencies, or for network and MARS operation.

POWER RATING: 180 watts P.E.P. input, and CW input, (with 50 ohm resistive load and 13.6 volt D.C. supply). Power output: 80 watts minimum P.E.P. and CW (100 watts typical).

EMISSION: SSB: Lower sideband on 40, 80, and 160 meters, Upper sideband on 20 meters with SB selector switch in NORM. position. Opposite with switch in OPP. Position. CW: Offset frequency.

UNWANTED SIDEBAND: More than 60 db down at 1000 cycles A.F. input.

CARRIER SUPPRESSION: More than 50 db down.

THIRD ORDER DISTORTION: Approximately 30 db below peak power.

SPURIOUS AND IMAGE OUTPUT: More than 40 db below peak power.

HARMONIC OUTPUT: More than 35 db below peak power.

CW KEYING: Manual send-receive. Semi-break-in with CW accessory installed in AC power supply console.

TRANSMIT CONTROL: Press-to-talk with Mic. Button, or manual transmit with function switch on front panel. Automatic voice control when VOX accessory is installed in AC power supply console.

MICROPHONE: Dynamic or crystal. Plug requirement: standard ¼ in. diam. 3 circuit phone plug.

AUDIO FIDELITY: 300 to 3000 cycles, plus or minus 3 db.

METER: Reads power amplifier collector current, 0-16 amperes.

LINEAR AMPLIFIER CONTROL: Rear jack provides for keying of linear, and ALC control from linear.

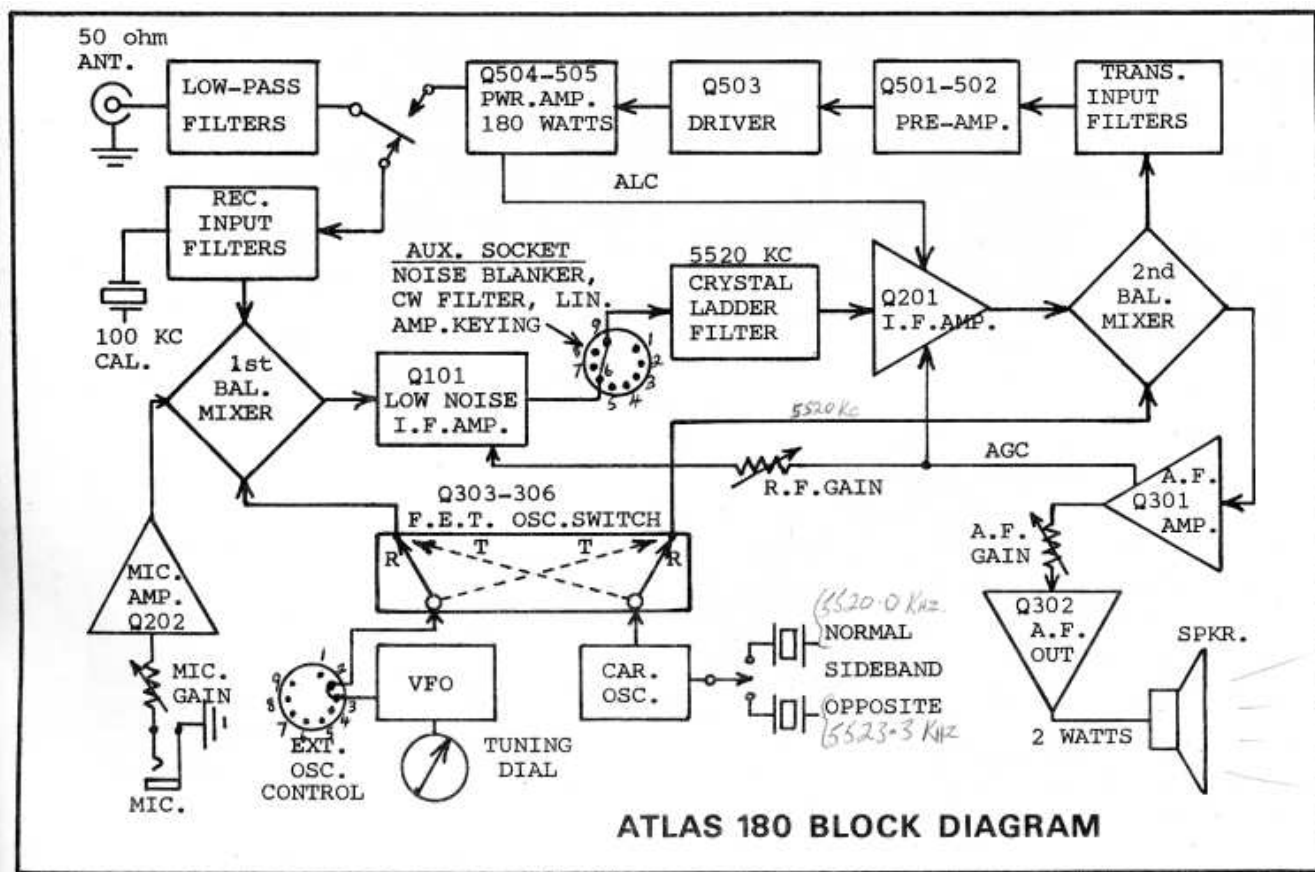

SPECIAL CIRCUIT FEATURES

The Atlas 180 employs several unique features in its circuit design which lead to exceptional performance. Most of the circuitry is directly descended from similar equipment manufactured for military and commercial markets by Southcom International, Inc. of Escondido California. Operating under license from Southcom, Atlas Radio has access to the very latest state-of-the-art circuit designs which have been tested, proven, and type accepted from military and commercial use.

Receiver input circuit:

Referring to the block diagram, notice that there is no preamplification of the signal. After passing through input tuning circuits the signal is coupled directly into a double balanced diode ring mixer where it is heterodyned to the 5520 kc I.F. Thus, the overload and cross modulation problems commonly encountered with an RF amplifier stage are largely eliminated. This has always been somewhat of a problem with vacuum tube R.F. amplifiers, and a much more serious problem with transistor or F.E.T. amplifiers. With its advanced front end design the Atlas 180 will continue receiving signals in the presence of extremely strong adjacent channel stations that would overload, cross modulate, or desensitize other receivers.

Sensitivity: As with most new developments in technology, it may be difficult to accept the fact that a proper receiver can exhibit good sensitivity without a stage, or more, of R.F. amplification prior to frequency conversion. The fact is that the Atlas 180 is at least as sensitive as the best of the tube or solid state receivers having R.F. amplifiers. This is due largely to the very low noise figure of the double balanced diode mixer, followed by a low noise I.F. amplifier. Sensitivity is rated at 0.3 microvolts for a signal-plus-noise to noise ratio of 10 db. Typical measurements will read 0.15 to 0.2 microvolts.

Selectivity: Following the low noise first I.F. amplifier, the signal passes through the crystal lattice filter, a highly sophisticated package designed specially for the Atlas 180 by Network Sciences Inc. of Phoenix Arizona. Here is where superior selectivity has been tailored to take full advantage of the extremely wide range of signal levels that the front end design is capable of handling. A 6 db bandwidth of 2700 cycles was carefully selected to provide audio response from 300 to 3000 cycles in both receive and transmit modes. While occupying slightly more bandwidth than a 2100 or 2400 cycle filter, it has been convincingly proven that the transmission and reception of the audio frequencies between 2400 and 3000 cycles provides a substantial improvement in weak signal readability.

At the same time, the improved fidelity of voice communication is readily noticeable.

The 6 db bandwidth of 2700 cycles is backed up by a 6 to 60 db bandwidth ratio of only 1.7 (shape factor), and ultimate rejection greater than 110 db. It is this extremely steep skirt selectivity which will reject strong adjacent channel signals.

Oscillator switching: The unique method of changing from receive to transmit mode by switching the carrier oscillator and VFO is illustrated in the block diagram. This new development is responsible for great simplification of the transceiver circuit, leading to fewer components, lower cost and greater reliability.

In receive mode the first mixer heterodynes the antenna signal with VFO injection. In transmit mode the first mixer functions as a balanced modulator with carrier oscillator injection and mic. amp. input. In both modes the first mixer output is at the intermediate frequency (I.F.) of 5520 kc.

In receive mode the second mixer functions as a product detector with carrier oscillator injection. Its output couples audio frequencies to the receiver audio system. In transmit mode the second mixer heterodynes the I.F. signal with VFO injection. Its output is now at the transmit frequency, and is coupled through tuned circuits, preamplifiers, driver stage, and power output amplifier.

Oscillator switching is accomplished with four F.E.T.s resulting in very low intercoupling between oscillators.

Transmitter Broadband Circuitry: The amplifier stages of the transmitter provide full power output over the entire 1.8 to 15 mc range, and require no tuning. Tuned circuits between the second mixer and the transmitter amplifier module select the desired mixer product and reject the unwanted products. These tuned circuits are band switched and provide full coverage of each band. They are double tuned and over coupled, requiring no further adjustment after being factory set.

Harmonic output from the power amplifier is suppressed by a band switched two section low pass filter. This filter is connected between the power amplifier output and the antenna terminal. The low pass filters and power amplifier are both designed for a 50 ohm load. It is important that the load be quite close to 50 ohms, non reactive, in order to operate at full rated power.

Receiver Broadband Circuitry: The receiver input filters are band switched, and provide full band coverage without need for a panel peaking control. In addition, the signal passes through the low pass transmitter filter, suppressing possible interference from strong local VHF signals.

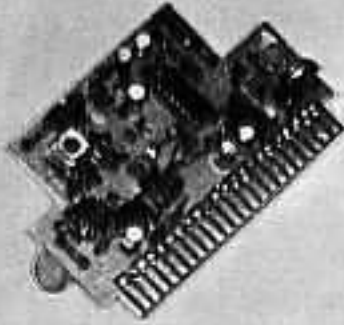

I.F. MODULE
PC-200

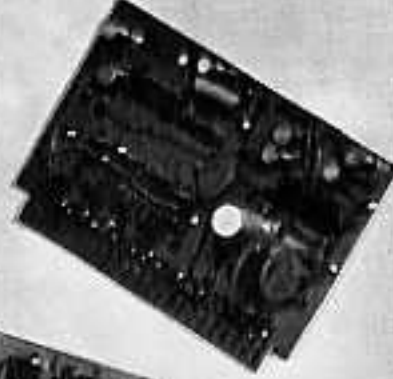

A.F. MODULE
PC-300

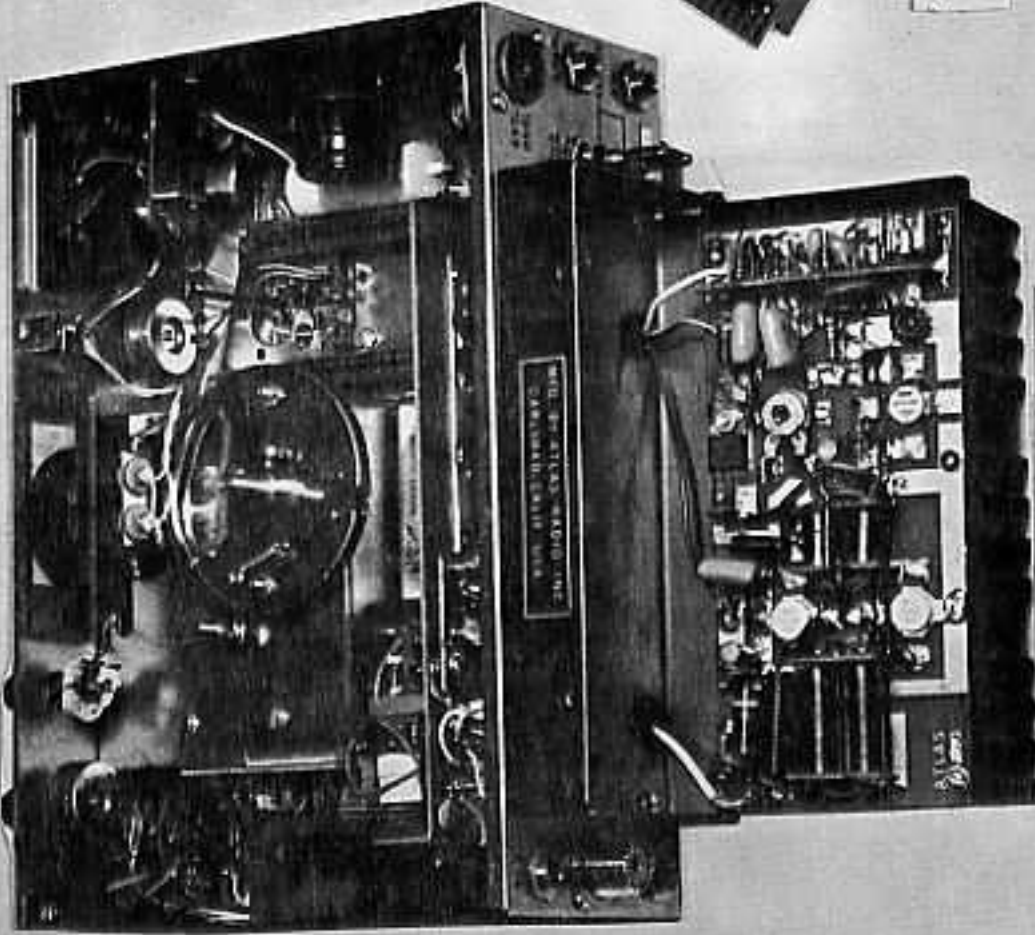

SWIVEL MOUNTED
POWER AMPLIFIER MODULE

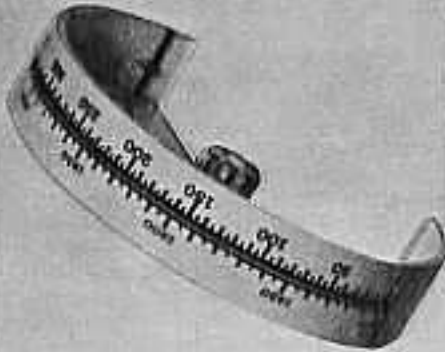

TUNING DIAL DRUM

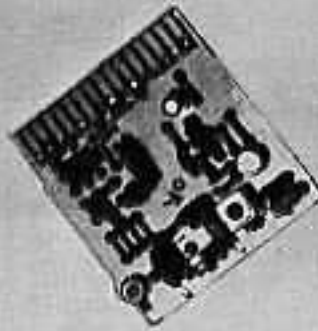

R.F. MODULE
PC-100

ILLUSTRATING MODULAR DESIGN, PLUG-IN P.C. BOARDS OF ATLAS MODEL 180 TRANSCEIVER

MOBILE INSTALLATION

PRELIMINARY NOTES: The D.C. electrical system in an automobile may at times generate high voltage transients; spikes of voltage superimposed on the 12-14 volt D.C. system. These transients may be caused by faulty brushes in the starter motor, alternator or generator, or loose wiring, and can represent a possible hazard to the semiconductors in the transceiver. For this reason we strongly urge that you read the following notes and follow them carefully:

- (1) Clean the battery terminals and clamps, and tighten the clamps securely.

- (2) Tighten battery cable terminals where they attach to the engine.
- (3) Inspect battery cables and terminals for corrosion or wear. Replace them if they look questionable.
- (4) Check battery condition frequently, especially when it approaches its warranty age limit. Use a protective silicone grease on the terminals to inhibit corrosion.
- (5) Check the alternator and regulator connections for tightness. Also primary ignition wiring, horn wiring, lights etc.
- (6) Measure the charging voltage from the alternator with the engine running at about twice idling speed. Voltage at the battery terminals should measure 13 volts minimum, 14.5 volts maximum. Consult your auto-electric service shop if correction is required.

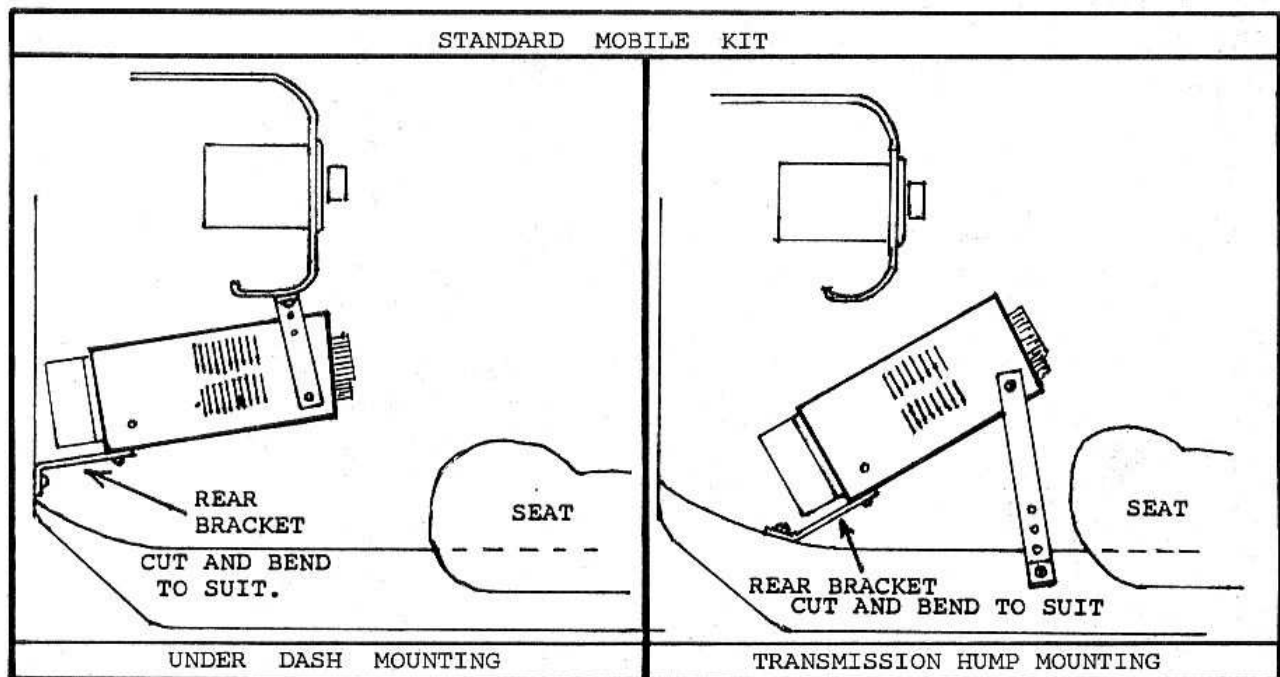

D.C. BATTERY CONNECTIONS:

See Addendum Note (3)

The illustrations show how the transceiver can be hung under the dash, or mounted over the transmission hump. Each installation is different, so this must be left to the individual. Consult your dealer or friends with mobile experience if need be. The brackets can be cut easily and bent as required. The smaller #6 x 3/8 in. screws are for attaching the brackets to the sides or bottom of the transceiver. They will replace the #4 x 1/4 in. screws that came in the transceiver, thus allowing for the 1/8 in. thickness of the bracket. The #6 screws will make the brackets more secure than the original #4s would. The #10 screws are for securing the brackets to the underside of the dash, or to the transmission hump.

NOISE SUPPRESSION

The subject of suppressing automotive ignition and alternator noise is beyond the scope of this instruction manual, so it will only be mentioned briefly.

Many cars will create very little interference in the HF bands covered by the Atlas 180. Almost all cars now use resistance type ignition wire, and will probably create very little ignition noise. More likely the high pitched whine from the alternator will cause more trouble. Refer to the various amateur radio handbooks, available from your dealer, for information on noise suppression. It will usually be found in the mobile chapters.

Estes Engineering Co., 543 West 184th St., Gardena, Calif., 90248, manufactures an excellent line of suppression kits which can help cure the more stubborn cases. It is quite likely that your dealer also sells the Estes Engineering line.

DELUXE PLUG-IN MOBILE MOUNTING KIT:

This kit includes: (a) 6 1/2 ft D.C. power cable with 20 amp in-line fuse and transceiver plug. (b) Black anodized plug-in housing. (c) Two 9 in. and two 12 in. black anodized aluminum mounting bars. (d) 3 in. wide rear brackets. (e) Three #10 x 1 in. sheet metal screws, and two 8-32 bolts, nuts, and washers

Refer to the illustrations for typical transmission hump and under-dash mounting arrangements.

- (1) The rear bracket(s) should be angled as straight back as possible in order to give good support for pushing and pulling the transceiver in and out of the mount.
- (2) The mounting brackets must be cut and bent to suit the installation, each case being unique. Try different

positions and select the one for best ease of operation, and least interference with automotive controls. Then carefully measure each bracket for length and angle of bend on its foot.

- (3) Remove the acorn nut and hex nut. Slip bracket over screw, and replace only the acorn nut.
- (4) Secure brackets to car with #10 sheet metal screws. Tighten screws and nuts securely.
- (5) Connect 52 ohm coax. cable as illustrated.
- (6) An external speaker may be connected as follows: Locate the speaker plug on the back of the mobile mount, just above the mic. Plug. Clip out the wire jumper going from the tip lug to the ring lug. This will disconnect the internal speaker. Connect the external speaker from the tip lug to the ground lug.

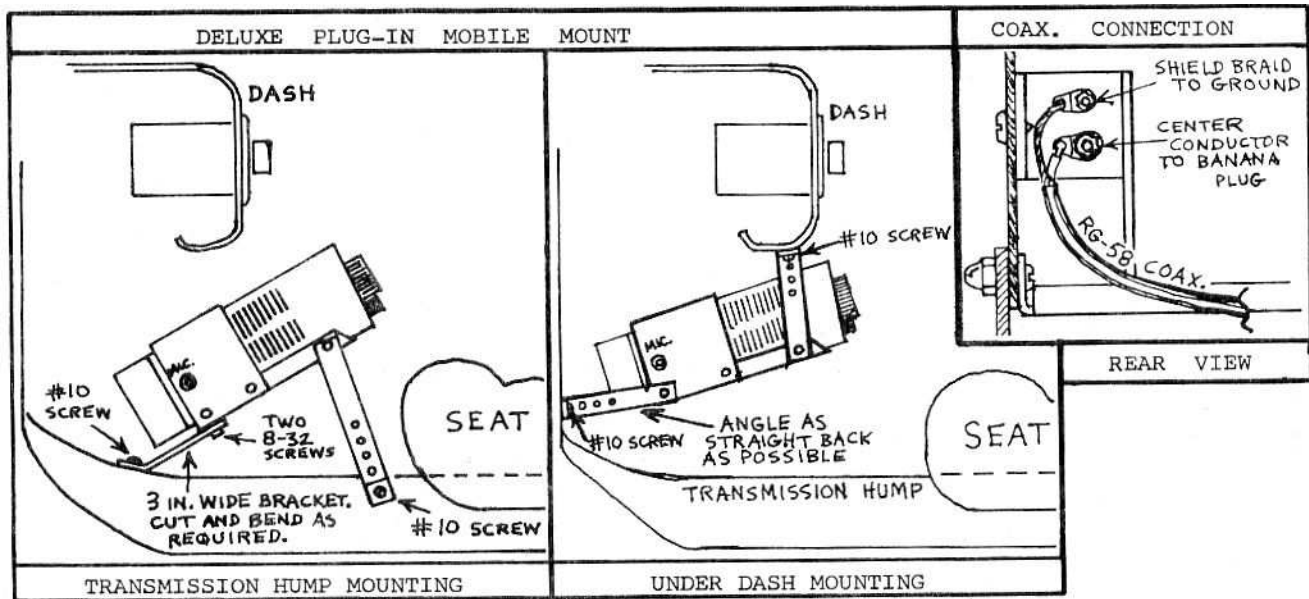

INSTALLING D.C. POWER CABLE:

The power cable should be run from the transceiver, through the bulkhead, and connected as close to the battery as is practical. The best way is to connect directly to the battery posts. Drill and tap into the lead terminal posts for 10-32 machine screws, and secure #10 terminal lugs under these screw heads. The advantage of doing it this way is that even if the battery clamps work loose, it will not affect the transceiver connections, and the danger of intermittent transient voltage spikes will be reduced.

If drilling and tapping the battery posts is not practical, then connect the cable to the engine end of the battery cables. The negative cable will usually be found going to a bolt on the engine block, while the positive cable usually goes to a bolt on the starter solenoid. Install terminal lugs at these points for connecting the power cable.

The red lead goes to positive and the black to negative. A protective diode is built into the transceiver plug and will blow the in-line fuse if polarity is inadvertently connected wrong.

As discussed in Preliminary notes, the battery clamps should be cleaned and tightened. All electrical connections should likewise be checked and tightened.

OPTIONAL SAFETY FUSE:

The D.C. power cable has a 20 amp. in-line fuse installed close to the transceiver plug. This is a convenient location, but is not always the best. A more proper location is to install a fuse close to the battery end of the power cable. There is always a possibility of short circuiting a cable to ground, either by having a bulkhead cut through the insulation, or getting pinched somewhere. With 12 gauge wire and no fuse at the battery end, the short circuit could start a fire very quickly. A second in-line fuse, fuse block, or circuit breaker may be installed near the battery if you're a worry wart. Otherwise, install the cable carefully, using tape, grommets, and plastic cable clamps where necessary.

MODEL AR-117 and AR-230 POWER SUPPLY SPECIFICATIONS

** INPUT VOLTAGE: AR-117: 117 volts AC, AR-230: 117 or 230 volts AC, (switch selected). Both models 50-60 cycles.

** INPUT POWER: 10 watts average, Receive. 250 watts Transmit peak.

** OUTPUT: Low current line: 13.6 volts regulated ½ amp. High current line: 13 volts at 16 amps.

** SPEAKER: 3 x 5 in. oval, 1.1 oz. Magnet, 3 ohm voice coil.

** PLUG-IN DESIGN: Transceiver plugs directly into power supply console, automatically makes connections for antenna and front facing speaker. Mic. Jack and headphone jack are brought out to front panel.

** ACCESSORIES: Space under transceiver permits addition of VOX unit. Space in rear permits addition of semi-break-in CW/sidetone unit.

** FINISH: Textured vinyl bonded to steel, durable and scratch resistant

** DIMENSIONS:
 15 ½ in. (39.4 cm) wide.
 5 5/8 in. (14.3 cm) high.
 9 ½ in. (24.1 cm) deep.

** WEIGHT: 17 lbs. (7.7 kg), less transceiver. 20 lbs. Shipping weight.

AR-117 SCHEMATIC DIAGRAM

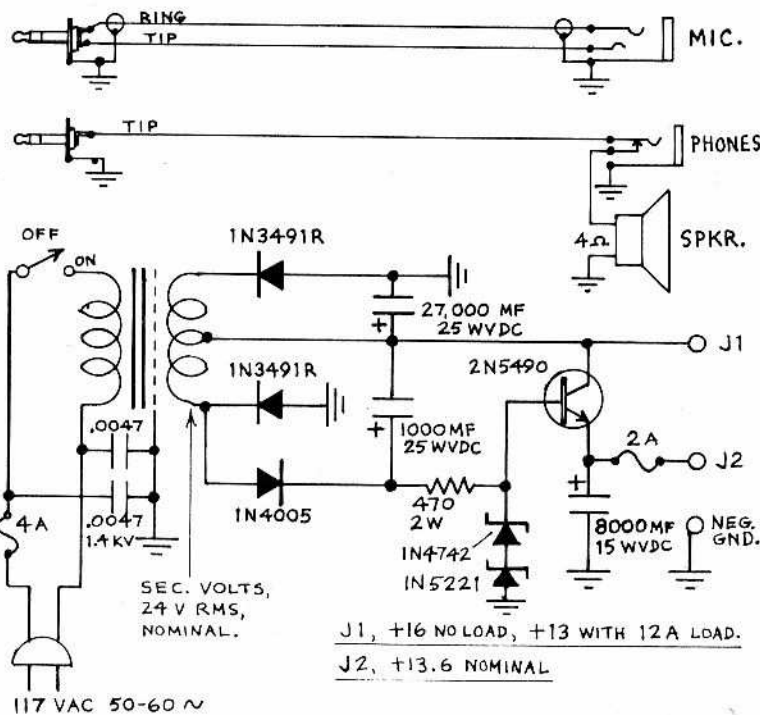

MICROPHONE CONNECTIONS

The microphone may be either a dynamic or crystal type. If a dynamic is selected, it should preferably be the high impedance type. A low impedance mic. will work, but will require higher setting of the Mic. gain control, and may require closer speaking.

The choice of microphone is important for good speech quality and deserves careful consideration. Select a high quality mic. with smooth response from 300 to 3000 cycles or more. An excellent choice is the Sure 404C hand mic.

PLUG CONNECTIONS: The plug required is a standard ¼ in. diam., 3 conductor type. The tip connection is the keying circuit for the press-to-talk, the ring connection is for the shielded mic. lead, and the sleeve or barrel is the common ground terminal.

VOX OPERATION: Most press-to-talk microphones are short circuited when the button is not pressed. For VOX operation this feature must be disabled. Refer to instructions that come with the mic. Open the case and locate the switch contacts that short the mic. circuit when the button is not pressed. Either disconnect the leads or bend the contacts so they do not make.

LINEAR AMPLIFIER CONNECTIONS TO ATLAS-180 TRANSCEIVER

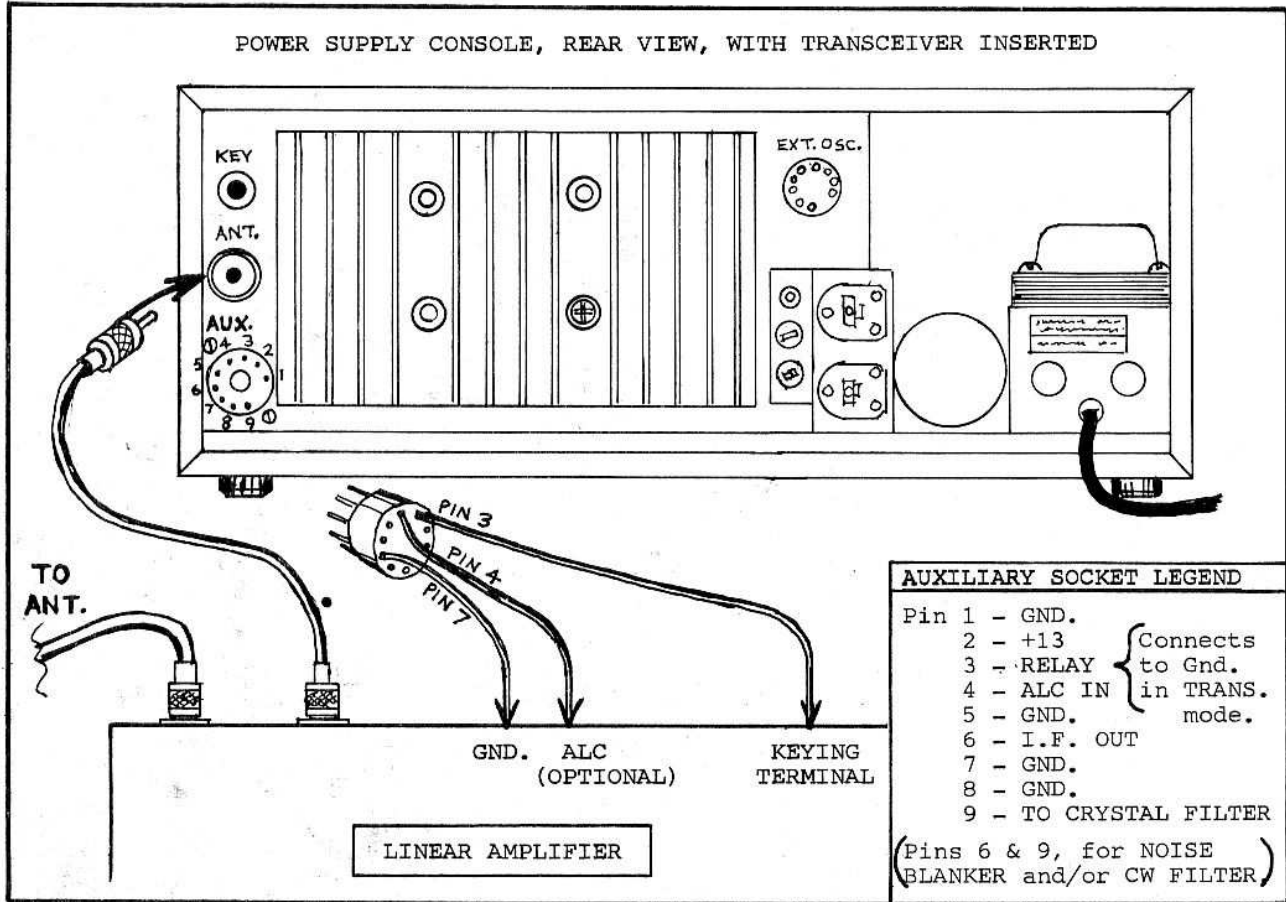

ATLAS 180 OPERATION

CONTROLS:

POWER SUPPLY ON/OFF, MOBILE: The function switch has an OFF position which turns off the DC power supply to the low current circuits. The high current circuits, (driver and P.A.), remain connected to the DC supply line, but are automatically biased off when the low current line is turned off.

POWER SUPPLY ON/OFF, AC CONSOLE: The AR-117 AC console has an On/Off toggle switch which turns off the AC supply line. This switch should be used rather than the function switch OFF position.

FUNCTION SWITCH: First position is OFF for mobile operation. "REC" position places the 180 in receive mode. Press-to-talk and VOX circuits are operative in this position. "TRANS" position switches the 180 into Transmit Mode in the event a mic. without a press-to-talk switch is used, or if you wish to hold in transmit mode without having to hold the button down. "CW" position is also transmit mode except that the mic. gain control now becomes a carrier insertion control and carrier frequency has been shifted about 500 cycles. (See CW TRANSMISSION).

A.F. GAIN: Controls audio volume in receive mode.

R.F. GAIN: The purpose of the R.F. gain control is to permit decreasing of the between-speech noise level, thus providing more pleasing reception. The AGC system in the Atlas 180 has a tremendous dynamic signal range. With full R.F. Gain sensitivity will automatically return to maximum in the absence of a signal, accompanied by a natural increase in background noise.

You may find it annoying to hear the noise level increase every time the person being received pauses between words or sentences. There are really only two conditions when the R.F. Gain control needs to be on full. One is when you are scanning the band and want to hear weak as well as strong signals with about the same audio volume. The other condition is when you are in a round table with both weak and strong signals. But, a lot of the time you can turn the R.F. Gain down a bit, increase the A.F. Gain correspondingly, and realize more pleasing reception.

BAND SELECTOR AND THE TUNING DIAL: The first position on the band switch is marked "1.8" for the 1800-2000 kc, or 160 meter band. The upper dial scale is calibrated directly for this band.

On the other bands the lower dial scale is used. It is calibrated in 5 kc increments from 0 to 350, and the dial reading is mentally added to the number on the band switch.

For instance, in the 3.5 position a dial reading of 0 is 3500 kc, a reading of 100 is 3600, etc. In the 3.7 position a dial reading of 0 is 3700 kc, a reading of 100 is 3800, and a reading of 300 corresponds to 4000 kc, the upper limit of the 75 meter phone band. 80 and 75 meters are the only bands that require a little mental getting used to.

The 40 and 20 meter, (or 7 and 14 mc) bands read out directly on the dial, with 0 to 300 tuning from 7000 to 7300, and 0 to 350 tuning from 14,000 to 14,350 kc.

PROPER TUNING OF SINGLE SIDEBAND SIGNALS:

Precise tuning of a single sideband signal is very important. Try to tune exactly to the frequency where the voice sounds normal. Avoid the habit of tuning so the voice is pitched higher than normal, and sounds like Donald Duck. This is an unfortunate habit practiced by many operators. If you tune for an unnatural high pitch, you will then be off frequency when you transmit. Chances are the other station will then shift to your frequency when you are talking, etc., and gradually you will move up or down the band. Sooner or later one of you will accuse the other of drifting..... So, take the extra care to tune for a natural sounding voice, and you will then be enjoying the very best quality in voice communications.

ADJUSTMENTS

TUNING KNOB TENSION: Adjustment has been provided for increasing or decreasing the torque required to turn the main tuning knob. Loosen the set screw and remove the knob. You will find a curved spring washer between two flat washers on the tuning shaft. Compressing the spring washer increases the torque. When tightening the set screw, apply inward pressure on the knob to produce the amount of tension you want. In home station use you may want no drag at all, while for mobile use you may prefer quite a bit.

P.A. BIAS: this adjustment is on the back of the heat sink, and requires a small Phillips screwdriver. Idling current in TRANS mode should read ½ to 1 amp. Do not measure idling current in CW mode, as it may give a false reading. After a period of voice transmission the idling current may climb to nearly 2 amps., but will drop back when the heat sink cools. Temperature compensation of the bias supply prevents thermal runaway.

CARRIER BALANCE: A trim pot. is located on the PC-100 plug in board on the right side of the transceiver. Next to the trim pot. is a capacity trimmer which is the phase control. These trimmers should be adjusted for minimum carrier on the 1.8 mc band.

Connect a dummy load to the transceiver, and measure the output voltage in TRANS mode with the Mic. gain at minimum. It should null down to a level of 0.1 to 0.15 volts RMS. Other bands will give a false reading due to oscillator feedthrough which is not suppressed as much as the carrier.

S-METER ZERO: This is a trim pot. located on the PC-200 plug in board located under the dial drum. It can be reached with a Phillips screwdriver from the top, just behind the dial light switch. Disconnect the antenna and adjust the trim pot. for meter 0.

ALC ADJUSTMENT:

See Addendum Notes (1) and (2)

CRYSTAL CALIBRATOR: The 100 kc calibrator should be checked every 6 months, or so, against a frequency standard such as WWV. Aging will cause it to gradually change frequency especially during the first few months. The calibrator is on the PC-800 board, mounted on the front side of the aluminum partition behind the dial drum. A capacity trimmer in the upper left hand corner is for frequency adjustment. A test lead may be run from terminal #1 of PC-100 to the antenna terminal on a general coverage receiver which is tuned to one of the WWV frequencies: 2.5, 5, 10, or 15 mc. Adjust the trimmer for zero beat when WWV interrupts their tone modulation.

VOICE TRANSMISSION

Normal operation is with the function switch in REC. position. Pressing the mic. button switches the transceiver into transmit mode. Or, if the VOX accessory is installed in the AC console, speaking into the mic. will switch the rig into transmit mode.

A TRANS. Position is also provided on the function switch for locking in the transmit mode, or in case the mic. does not have a press-to-talk switch.

MODULATION LEVEL is adjusted with the mic. gain control. When the transceiver is coupled into a proper 52 ohm load, voice peaks will be reaching about 16 amps., although the ammeter cannot respond quickly enough to respond to these peaks. Adjust the mic. gain for average readings of 5 to 7 amps. Do not run the gain above this level, or you will flat-top and distort the transmitted audio, as well as cause splatter up and down the band. ALC will help reduce this danger, but it is still possible to overmodulate, so mic. gain must be adjusted carefully.

CW TRANSMISSION

The Function switch has a CW position which switches the transceiver into CW transmit mode. A jack on the back is provided for insertion of a standard ¼ in. diam. 2 conductor phone plug coming from the CW key. Keying is accomplished by bias cutoff of the I.F. amplifier. The keying circuit operates at less than 10 volts positive to ground, and draws less than 5 milliamps., so any of the electronic keyers will work OK.

In CW transmit mode the carrier frequency is automatically shifted 400 to 600 cycles. This makes it possible for one transceiver to QSO another transceiver on CW without having to constantly tune the dial back and forth. On 160, 80, and 40 meters the transmit frequency is shifted lower than the receive frequency, while on 20 meters it is shifted higher. The SB selector switch must be in the "NORM" position for CW operation.

Send-receive changeover must be made with the function switch, and it may be a bit inconvenient to pass through the TRANS. position every time. The serious CW operator will want to install the semi-break-in accessory kit in the AC console. This item installs in back of the power supply, and includes a sidetone oscillator with volume, pitch and delay controls.

In CW mode the Mic. Gain control becomes a carrier insertion control. With key down, advance this control clockwise until the meter reads 12 amps. This will be 160 watts input power, (at nominal supply voltage) and output will be about 80 watts.

For novice class operation, insert 6 amps. of carrier for the 75 watt legal limit.

Adequate ventilation for the heat sink is particularly important in CW operation, since average power input is higher than in SSB transmission. Keep a check on heat sink temperature, and if it is running uncomfortably hot to the touch, back down on carrier insertion, or make the transmissions shorter.

CAUTION---CAUTION HEAT SINK TEMPERATURE

The greatest danger to the power output transistors is overheating. The black anodized heat sink is designed to cool the transistors adequately under normal operating conditions, but as with any electronic or mechanical device, it is up to the operator to maintain normal conditions, and not abuse the equipment.

The maximum safe temperature of the heat sink near the output transistors is about 150 deg. F. This is a temperature that will be too hot for your fingers to hold, so a good test is to put your fingers on the fins closest to the transistors. If you can hold on without a lot of discomfort, you're OK.

Overheating may be caused by: (a) modulating too heavily, (b) making lengthy transmissions with short receiving periods, or (c) restriction of air circulation around the heat sink. If the air temperature is high, such as on a hot day, or in a hot parked car, cooling capacity will be reduced. A good rule is to check the heat sink from time to time, and make certain you're not running too hot. Back off on modulation level, or shorten transmission time. Under abnormal conditions, a small fan may be directed at the heat sink. This is an excellent idea if SSTV or RTTY transmission is contemplated.

ANTENNA-TRANSMISSION LINE MATCHING

Proper impedance match between the coaxial feedline and the antenna system is considerably more important with the broadbanded solid state amplifier than with tube type transmitters, which generally have a Pi type matching network. The SWR should be as low as it can be in order to permit full power operation. As SWR increases, power output from the Atlas 180 decreases approximately as indicated in the following chart.

<u>SWR</u>	<u>Approx. Output</u>
1.0	100 watts
1.1	98
1.2	95
1.3	90
1.5	80
2.0	50
3.0	20

Note: High SWR will not damage the Atlas 180. You may feel free to operate. Only power input and output will suffer. Reflected voltage will not cause damage.

AMMETER READING: The ammeter on the Atlas 180 provides an excellent indicator of impedance match. In CW transmit mode the Mic. Gain control becomes the carrier insertion control. With a close match you will be able to run the ammeter up to 12 amps., or more. (with supply voltage of 13.6 VDC, or 117 VAC)

If you find you can't run the amps. that high, you can be quite sure that the antenna is not matched well at that frequency. Try different parts of the band, and you can tell easily at what frequency the antenna works best.

INFINITE SWR PROTECTION: The Atlas 180 has a built in reflectometer which automatically reduces transmitter drive as SWR increases. This makes the power output transistors nearly immune to damage from mismatched loads.

ANTENNAS, FIXED STATION

On 20 meters a doublet and most beam antennas will match quite well across the entire band.

On 40 meters a doublet tuned for phone band center will match quite well across the band.

On 75 meters the average doublet will have a bandwidth of about 100 kc for SWR of 1.5 or less. To work the entire band with full efficiency will require an antenna tuner.

On 160 meters an antenna tuner, or at least some kind of matching system will be essential, since even at resonance it is unlikely that the feed point will be near 52 ohms.

In any case, it is always best to optimize the antenna system for the frequency where you do most of your operating.

ANTENNA TUNER OR "MATCH BOX" :

An antenna tuner can be a very useful device to compensate for antenna mismatch. This may be especially true if you happen to have a favorite antenna that has been working just fine with the old tube rig, and now you discover the new solid state rig doesn't like the old antenna. Refer to the antenna handbooks for helpful data, or ask your dealer about antenna tuners now on the market.

Atlas Radio will be announcing a matching antenna tuner about October 1, 1974.

SWR MEASUREMENTS

A bridge for measuring Standing Wave Ratio is very useful, and strongly recommended for checking impedance match. Use the following procedure:

- (1) Switch the bridge to "Forward" or "Sensitivity" position.
- (2) Set the sensitivity control on the bridge to maximum clockwise position.
- (3) Set Mic. Gain on Atlas 180 to minimum.
- (4) Set the 180 function switch to CW mode.
- (5) Advance the Mic. Gain until meter on bridge reads just full scale. (Mic. Gain is carrier insertion control in CW mode).
- (6) Switch bridge to "SWR" or "Reflected" position for the SWR reading.
- (7) Tune the 180 up and down in frequency until you locate the minimum SWR. This will indicate the resonant frequency of the antenna, and also the SWR at that frequency.
- (8) Switch the 180 back to REC. mode.

CAUTION: Operate the transceiver in CW mode for only short periods of time, just long enough to make the SWR measurement. Check heat sink temperature during SWR tests, and if it is getting quite warm to the touch, let the rig cool for a few minutes before continuing.

MOBILE ANTENNAS

The mobile antenna generally requires more critical adjustment than the home station antenna. This is because it operates over a more narrow bandwidth, and must therefore be adjusted very accurately for resonance. Also, the base impedance is seldom very close to 52 ohms. With tube type transmitters the Pi matching network will adjust to fairly low impedances, but with a broadband solid state transmitter, such as is used in the Atlas 180, a close impedance match is necessary in order to operate at full power.

Various claims about impedances are made by manufacturers of mobile antennas, but unfortunately our tests on all the most popular brands indicate that your chances of coming up with a close match are less than 1 to 10. Average base impedance is 15 to 20 ohms. Therefore, some method for transforming the base impedance to 52 ohms is required.

ATLAS MODEL MT-1 TRANSFORMER: This is a broadband ferrite core transformer with a choice of 4 impedance taps. It installs inside the car body near the antenna mount. A coax feedline is run from the transceiver to the transformer and a short length is connected from the transformer to the antenna mount. There are taps for 13, 18, 23 and 52 ohms. One of these taps will provide a low SWR reading. Follow the procedure under "SWR Measurements". The MT-1 transformer is available from Atlas dealers.

CAPACITY MATCHING METHOD: This is an alternate method for matching to the mobile antenna which works quite well. A capacitor is connected from the antenna base to ground. This capacitor is part of an L network which transforms the base impedance from a low value up to 52 ohms. The small amount of "L" required is actually "borrowed" from the lower part of the loading coil.

The capacity value must be determined experimentally, and will vary from band to band, as well as from installation to installation.

On 75 meters the capacity will generally need to be in the 1000 to 1500 picoFarad range.

On 40 meters, 300 to 500 pF.

On 20 meters, about 200 pF.

A variable capacitor can be useful to determine what value is required. Or a collection of silver mica capacitors, some 100 pFs, 200s, 470s, and a 1000 pF can be paralleled in various combinations until the SWR comes down to a low figure.

Once you know how much capacity your antenna needs, it is best to make up a permanent capacitor by paralleling two or more silver micas. This will divide the R.F. current and reduce the chances of overheating a single capacitor with too much current.

Follow the procedure described under "SWR Measurements" when tuning the antenna.

PC-100A FIRST MIXER, FIRST I.F. AMP.

C101,108,109,110,112	10nF 100V disc
C102	22pF 10% disc
C103	50pF trimmer
C104,107	2nF mylar
C105	560pF mica
C106	160pF mica
C111	100nF 50V disc
C113	15uF 20V
D101,2,3,4,7,8.	1N4148
D105,6.	BA182
Q101	2N3866
R101	100R pot
R102	10K 0.25W
R103,110	4K7 0.25W
R104	330R 0.25W
R105	47R 0.25W
R106,7	1K 0.25W
R108	180R 0.25W
R109	820R 0.25W
L101,2	Trifilar toroid
L103	IF coil
L104	200uH choke

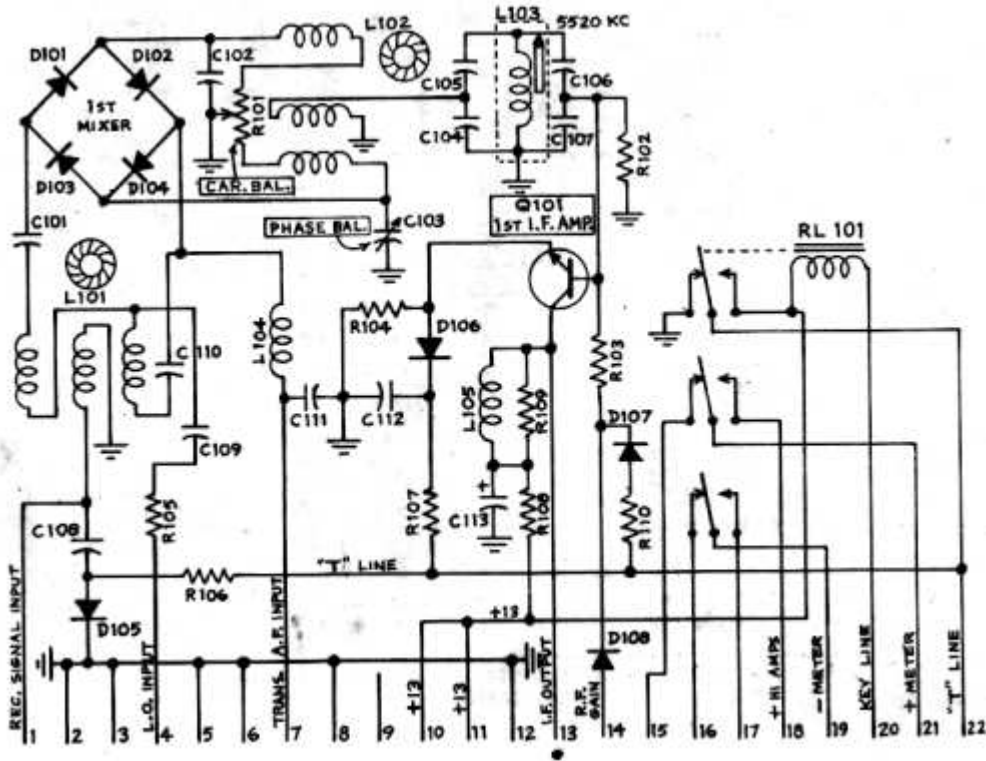

PC-200A, SECOND I.F. AMP., SECOND MIXER, MIC. AMP., S-METER AMP.

C201,214	15uF 20V	R201,220	2k2 0.25W
C202,3,5,8,9,210,213	10nF 100V disc	R202	220R 0.25W
C204,221	100nF 50V disc	R203	3K9 0.25W
C206	250uF 15V	R204	47R 0.25W
C207	750pF mica	R205	27K 0.25W
C212,216,219	1nF 20% disc	R206,211	5K6 0.25W
C211,220	2u2 50V	R207,212,219	470R 0.25W
C215	6u8 35V	R208,221	1K 0.25W
C217,218	22uF 16V	R209	68R 0.25W
L201	IF txfmr	R213	150K 0.25W
L202,203	Trifilar toroid	R214	100K 0.25W
L204	200uH choke	R215,217	10K 0.25W
D201,2,3,4,5	1N4148	R216	39K 0.25W
Q201	MC1350P	R218	3K9 0.25W
Q202	CA3086	R220	1K s-meter trim

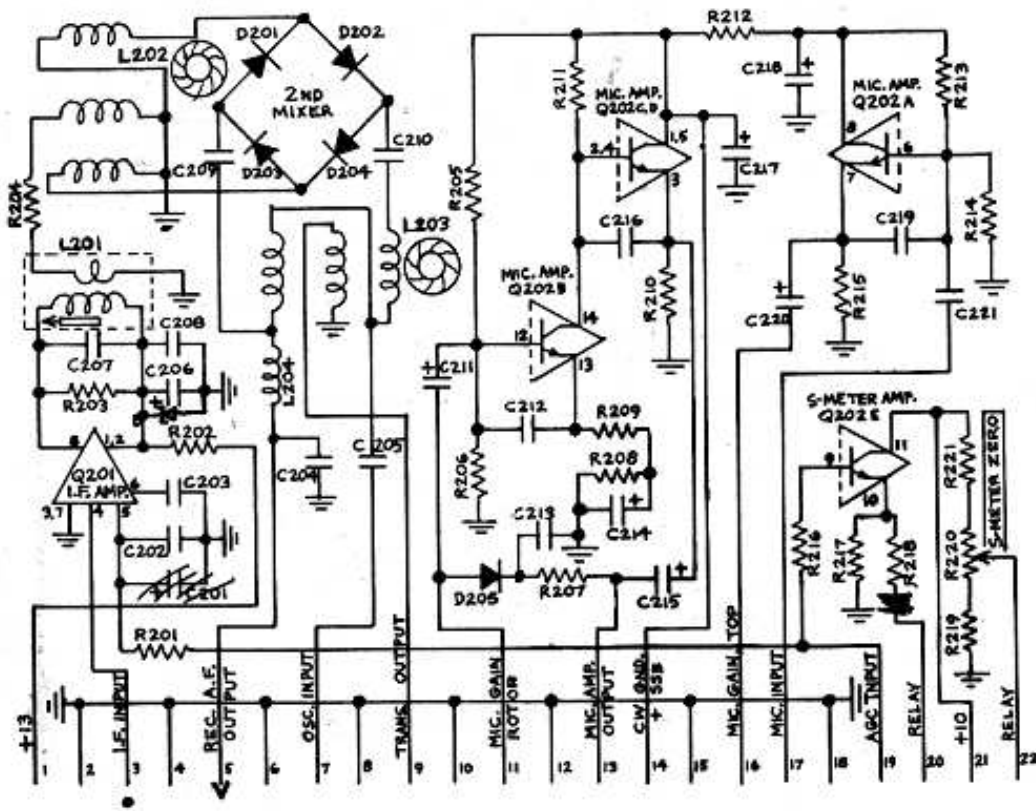

PC-300 RECEIVER AUDIO, OSCILLATOR SWITCH BOARD

C301,311	100nF 50V disc	R301,4,312	5k6 0.25W
C302,4,7,9,12,21,22,23,24	10nF 100V disc	R302	27k 0.25W
C303	220nF 25V disc	R303	100k 0.25W
C305	47uF 6V	R305	1K5 0.25W
C306,314,320	15uF 20V	R306,11,15,19,21,22,24	1k 0.25W
C308,316,319	2u2 50V	R307,8,9,17	470R 0.25W
C310	75uF 15V	R310	10K 0.25W
C313	47nF 100V	R313	1M 0.25W
C315	250uF 25V	R314	3K3 0.25W
C317	470nF 100V	R316,18,20,23,25,26	6k8 0.25W
C318	22uF 16V	Q301	CA3086
D301,302	BA182	Q302	LM380N
D303,4,5,6,7	1N4148	Q303,4,5,6	2N3819
L301	33uH choke		

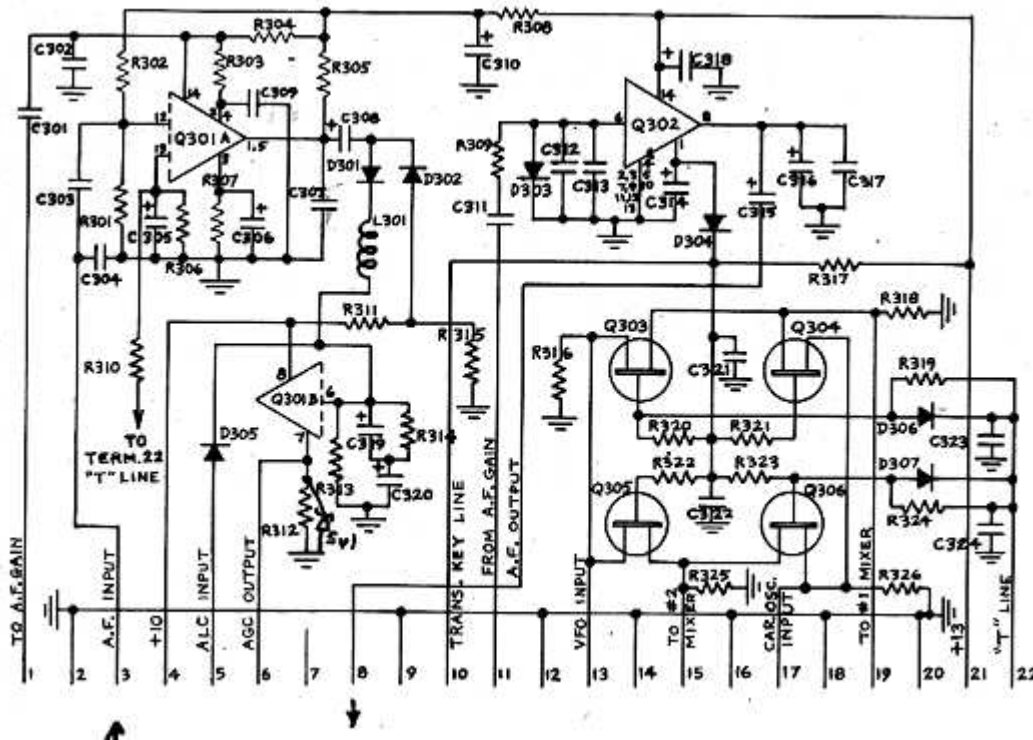

PC-400 VFO CIRCUIT BOARD AND TUNING CIRCUITS

C401,2,6,7,9	10nF 100V disc	R401,413	27R 0.25W
C403	300pF s-mica	R402,3,9,10	10K 0.25W
C404	430pF s-mica	R407	22k 0.25W
C405	10pF NPO disc	R404	470R 0.25W
C408	1nF disc	R405	680R 0.25W
C410	22pF N150 disc	R406	15k 0.25W
C411	15pF NPO disc	R408	820R 0.25W
C412	15pF N150 disc	R411,12	330 0.25W
C413,15,18,21,24	11pF trimmer	Q401,3	2N706
C414,16,19	10pF N150 disc	L401	3 section osc coil
C417,20	47pF NPO disc	L402	3.7MHz cal coil
C422,25	27pF N150 disc	L403	14MHz cal coil
C423	68pF NPO disc	L404	3.5MHz cal coil
C426	22pF NPO disc		
C427	1pF dial set		
C428a and b	8pF / sect main tuning		

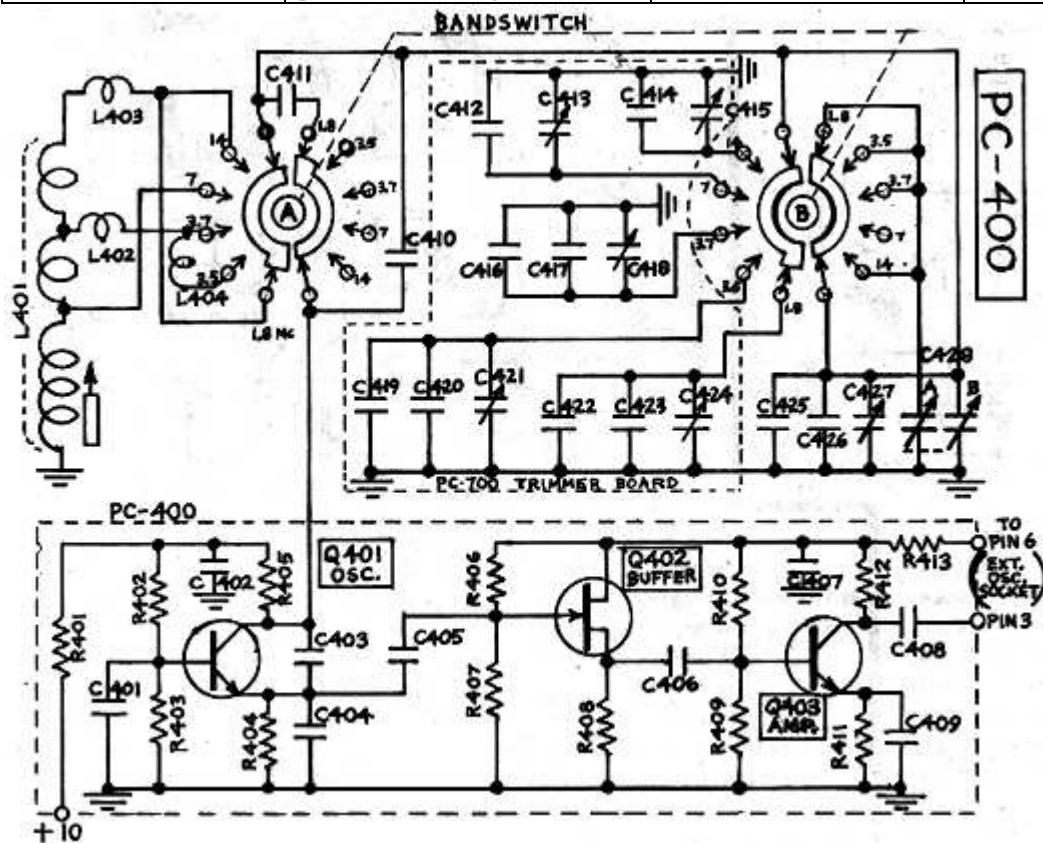

PC-500 PRE-AMPLIFIER, DRIVER, POWER AMPLIFIER			
C501,2,4,7,10,18,19	10nF 100V disc	R515	10k bias trim pot
C503,9	100nF 50V disc	R516	330R 0.25W
C505	2nF 600V mylar	R517	10R 2W
C506,12,17	100nF 100V mylar	Q501	MPS6514
C508,16	15uF 20V	Q502	2N3866
C511	2.2uF 50V	Q503	PT5766 (TRW)
C513,14	560pF 5% mica	Q504,5	CTC A50-12
C515	220pF 5% mica	Later Q504,5	CT1601
R501,8,14	1k5 0.25W	Q506	2N5490
R502	10R 0.25W	T501	toroid transformer
R503,9	470R 0.25W	T502	ferrite driver txfmr
R504,13	180R 0.25W	T503	ferrite output txfmr
R505	47R 0.25W	L501	33uH choke
R506	27R 0.25W	L502	1.4uH choke
R507	2k7 0.25W	L503	0.6uH choke
R510	470R 0.5W	L504	3 ferrite beads
R511	68R 0.25W	L505	1.5uh choke/shunt
R512	4x4R7 0.25W parallel	D501,2	SI-05

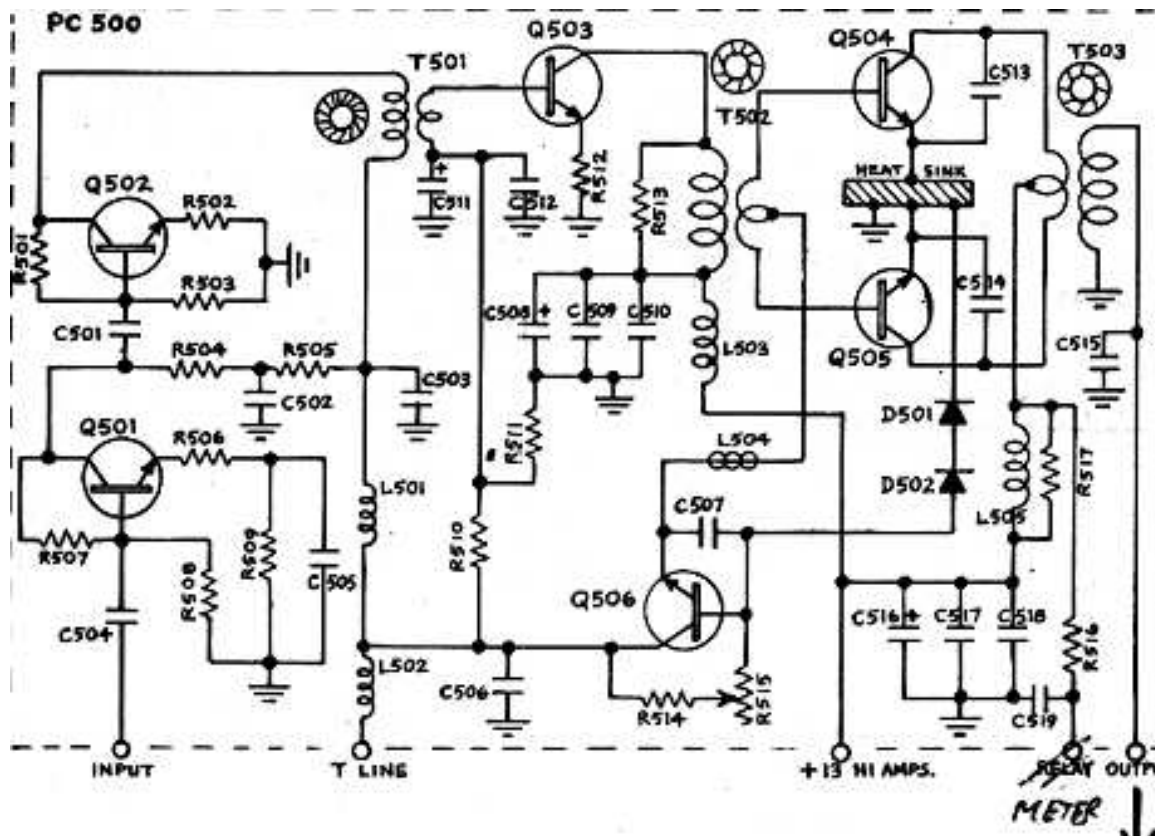

PC-600 CARRIER OSCILLATOR, BUFFER AMPLIFIER

C601	200pF 5% silver mica
C602	100pF 5% silver mica
C603	15pF 10% disc
C604,5,6,10,11	10nF 100V disc
C607	50pF trimmer (op SB)
C608	50pF trimmer (norm SB)
C609	10pF 10% disc
C612	520pF 5% silver mica
R601	22k 0.25W
R602	10k 0.25W
R603,6,12	1k 0.25W
R604,5	33k 0.25W
R607	470R 0.25W
R608,13	100R 0.25W
R609	4k7 0.25W
R620,11	15k 0.25W
L601	1.4uH
X601	5523.3kHz xtal (op SB)
X602	5520kHz xtal (norm SB)
D601	BA182
D602	1N4148
Q601,2	2N706

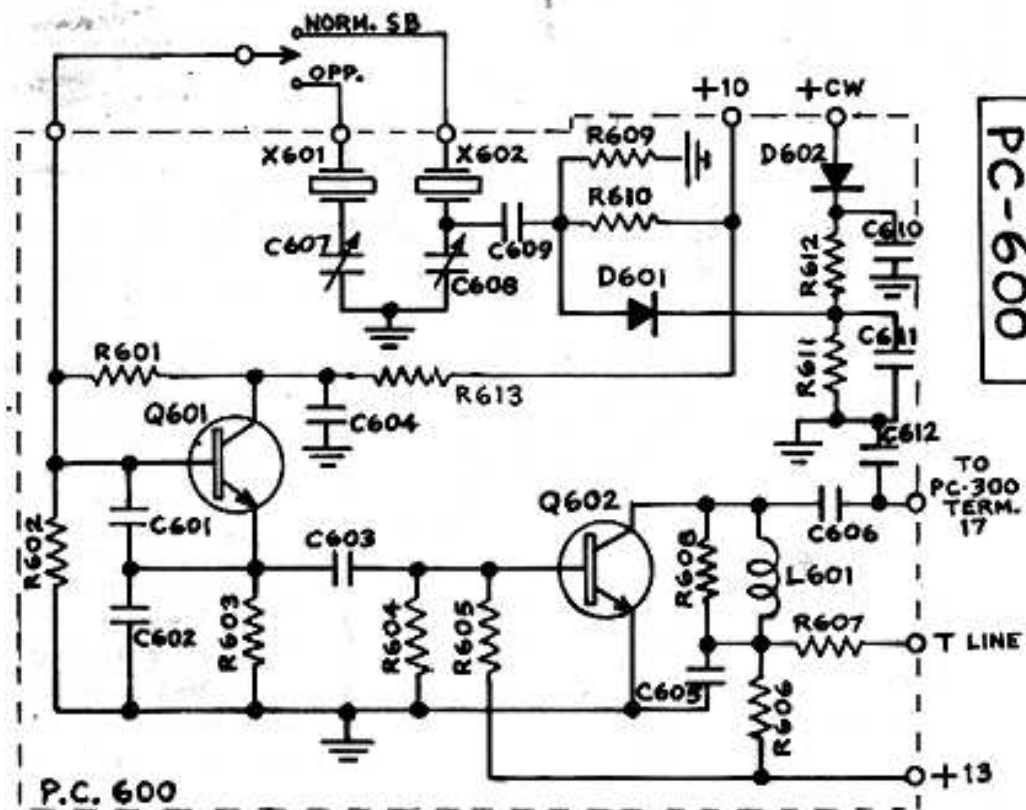

PC-800 REC. INPUT TUNING, 100 KC CRYSTAL CALIBRATOR

C801	680pF 10%
C802	50pF trimmer
C803	360pF 5% mica
C804, 5	3300pF polystyrene
C806	270pF 5% mica
C807, 8	680pF 5% mica
C809	4.7pF disc
C810, 13	91pF 5% mica
C811, 12	4-40pF trimmer
C814	0.047uF mylar
X801	100kc xtal
R801	470k 10%
R802	1k 10%
L801	5mH choke
L802	16.5uH coil
L803, 4	1.7uH coil
L805	3.7uH coil
L806, 7	1.4uH coil
L808, 9	1.2uH coil
D801	BA182
Q801	2N3819

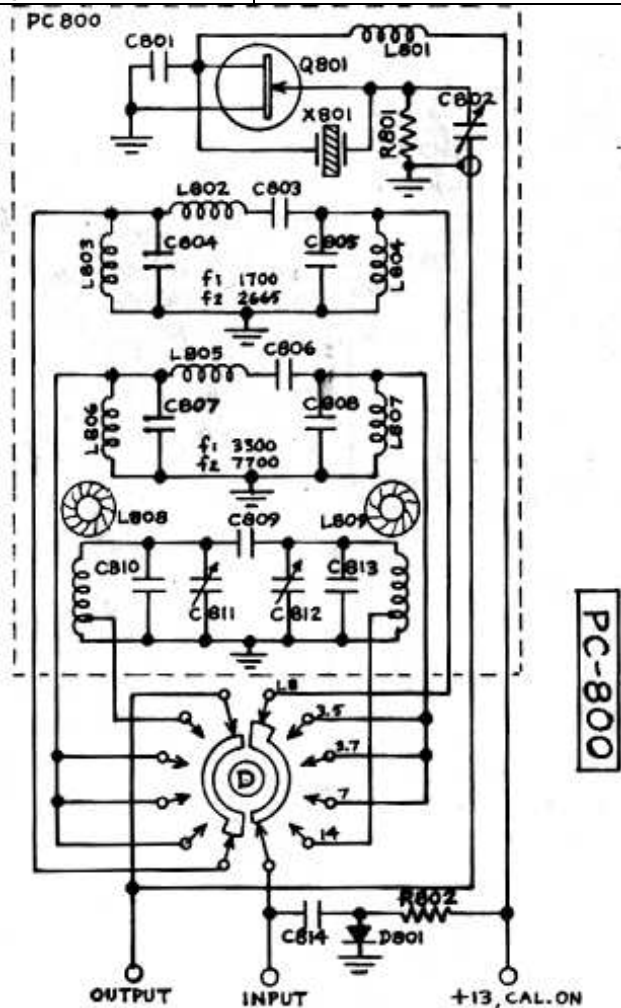

PC-800

PC-900 TRANSMITTER INPUT TUNING

C901, 4	820pF 5% poly
C902, 3	37-250pF trimmer
C905	100pF 5% mica
C906, 9	180pF 5% mica
C907, 8	10-80pF trimmer
C910,11,14,16,19	39pF 10% disc
C912,13,17,18	4-40pF trimmer
C915, 20	4.7pF 10% disc
R901, 2	4.7K 10%
L901, 2	2.8uH toroid
L903, 4	7uH toroid

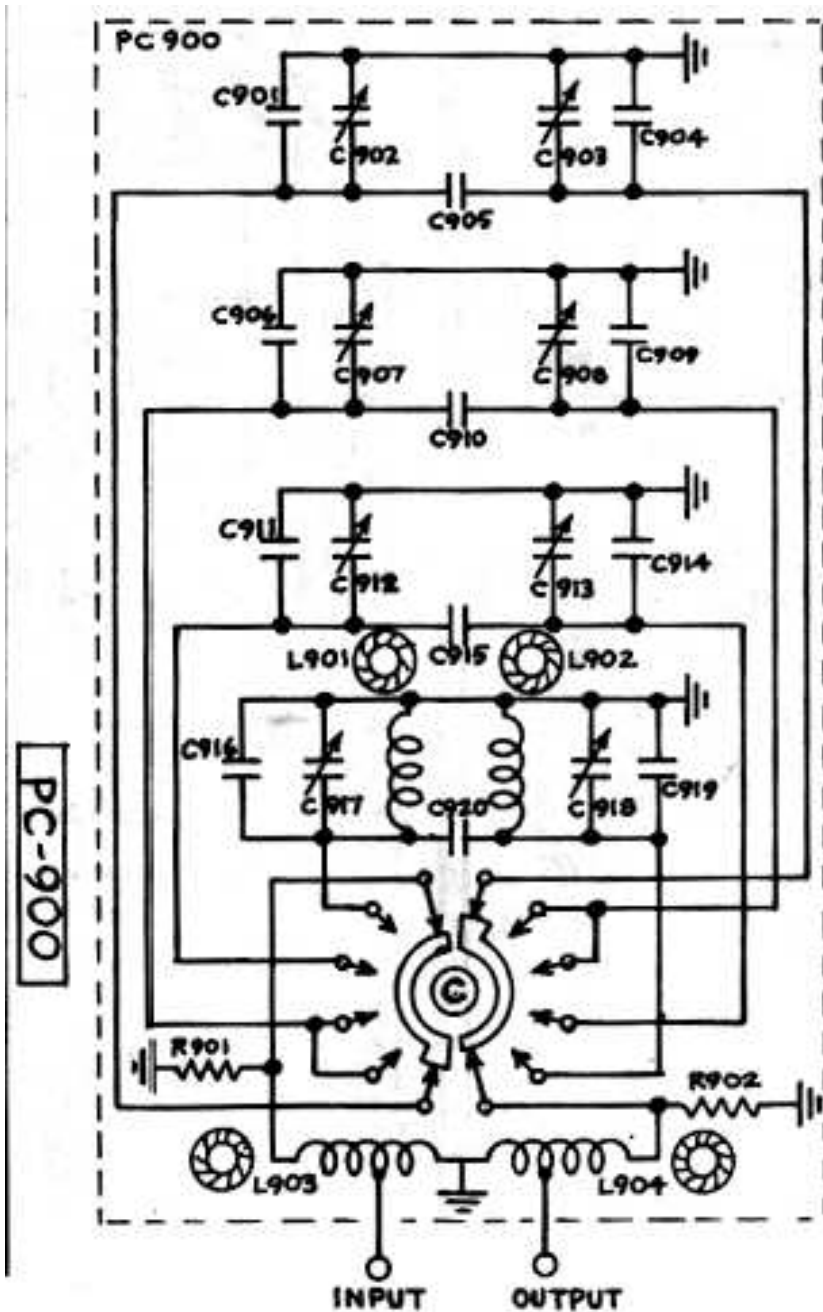

PC-1000/1020 LOW PASS FILTERS

C1001, 2, 3	2200pF 5% s-mica
C1005, 7	820pF 5% s-mica
C1006	1300pF 5% s-mica
C1008, 10	430pF 5% s-mica
C1009	680pF 5% s-mica
C1011	330pF 5% s-mica
C1012	220pF 5% s-mica
L1001, 2	2.9uH toroid
L1003, 4	1.8uH toroid
L1005, 6	0.95uH toroid
L1007, 8	0.48uH toroid

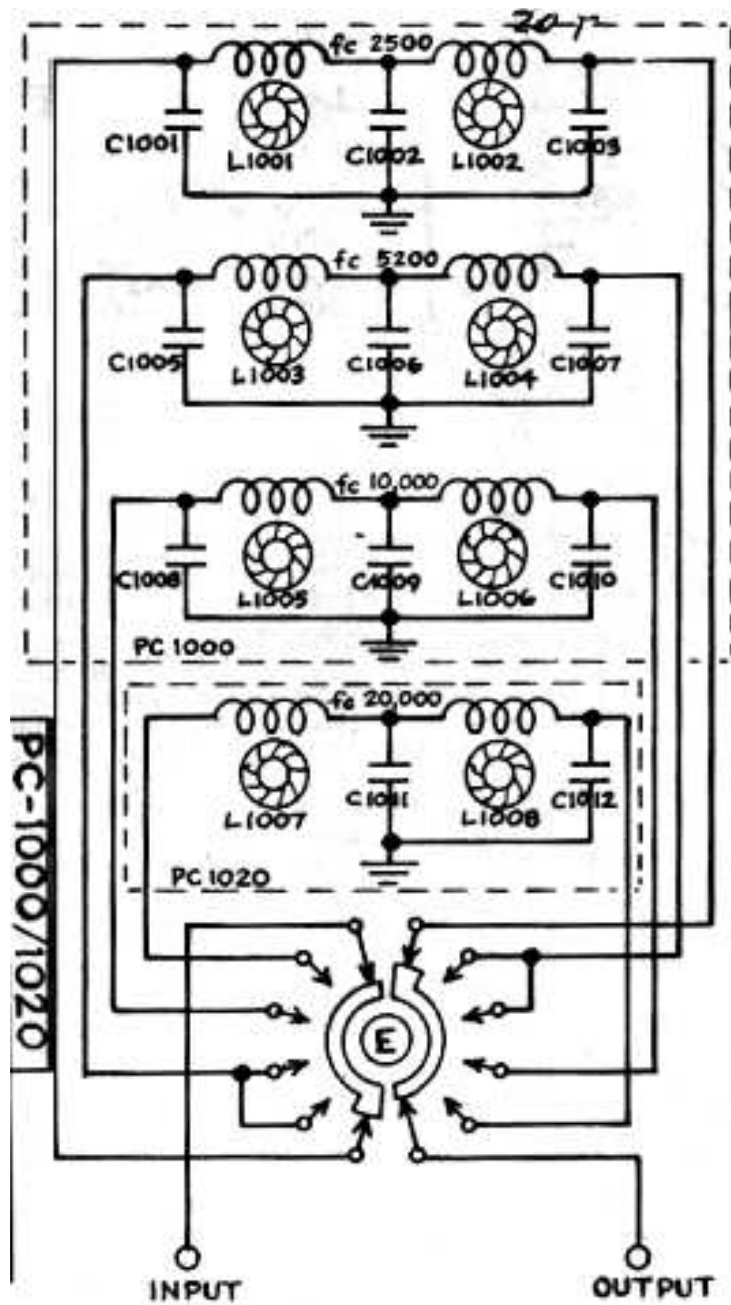

ATLAS 180 ADDENDUM NOTES:

- (1) The ALC CONTROL has been moved to the front panel. It is now concentric with the Mic. Gain control, and is the inner ring with a black set screw indicating its position.

ALC is the abbreviation for the "Automatic Level Control", and refers to transmitter modulation level. It aids in preventing over-modulation which causes flat-topping of the power output stages, distortion, and splattering outside the channel.

Full counterclockwise setting of the this control provides no ALC, while full clockwise setting is maximum ALC. Normally a setting around 12 o'clock will be satisfactory. Some variation between bands may be noted.

By having the ALC control on the front panel, you can utilize its advantages most effectively. Too little control will make it easier to over modulate, while too much control will limit output power. Try various settings and ask for signal reports until you become familiar with its effect. If you have a panoramic scanner, this is, of course, the best way to monitor your output signal.

FOR CW TRANSMISSION: The ALC Control should be set to minimum, or full counterclockwise position.

- (2) LINEAR AMPLIFIER OPERATION: The illustration on page 9 shows how to connect a linear amplifier to the Atlas 180. ALC output from the linear may be connected to pin 4 on the AUX. plug.

Special note: The ALC control voltage from the linear must be positive going. Most linears with an ALC output circuit are negative going. If this is the case with your linear, and you wish to utilize ALC control from the linear, it will be necessary that you modify the linear ALC circuit. This will usually consist of reversing one or two diodes in order to generate a positive voltage control instead of negative.

In view of this requirement, you may choose to use the ALC system of the 180 alone. Most linears will operate to the full legal power limit with little or no distortion.

If ALC control is coupled from the linear to the 180, then the ALC panel control on the 180 should be set to the minimum, or counterclockwise position.

- (3) **D.C. BATTERY CONNECTIONS:** A DELUXE MOBILE MOUNT – (DMK) is available from your Atlas dealer. This plug in design permits easy removal of the transceiver as all needed connections are made to the mount. All necessary hook up cables with polarity protection and hardware are part of the mount.

A MOBILE BRACKET KIT – (MBK) – can be purchased for a permanent installation in your car or boat as well as a factory built D.C. cable – (D.C.C.) with polarity protection and overload protection built in.

IN THE EVENT YOU HAVE NOT PURCHASED THE DMK OR D.C.C., your transceiver comes with two banana jacks for the positive battery lead, and are to be connected in parallel. The banana plug connects to the negative battery lead.

The battery leads should be of 10 or 12 gauge stranded wire of the automotive type. A 20 amp. fuse or circuit breaker should be installed in the positive lead.

Caution: It is extremely important that proper polarity be observed. The positive battery lead must go to the two terminals clearly marked on the back of the transceiver. The negative battery lead must go to the transceiver chassis ground, and the banana plug is for this purpose. Even momentary connection of the wrong polarity will destroy the transistors, and void the Atlas warranty.

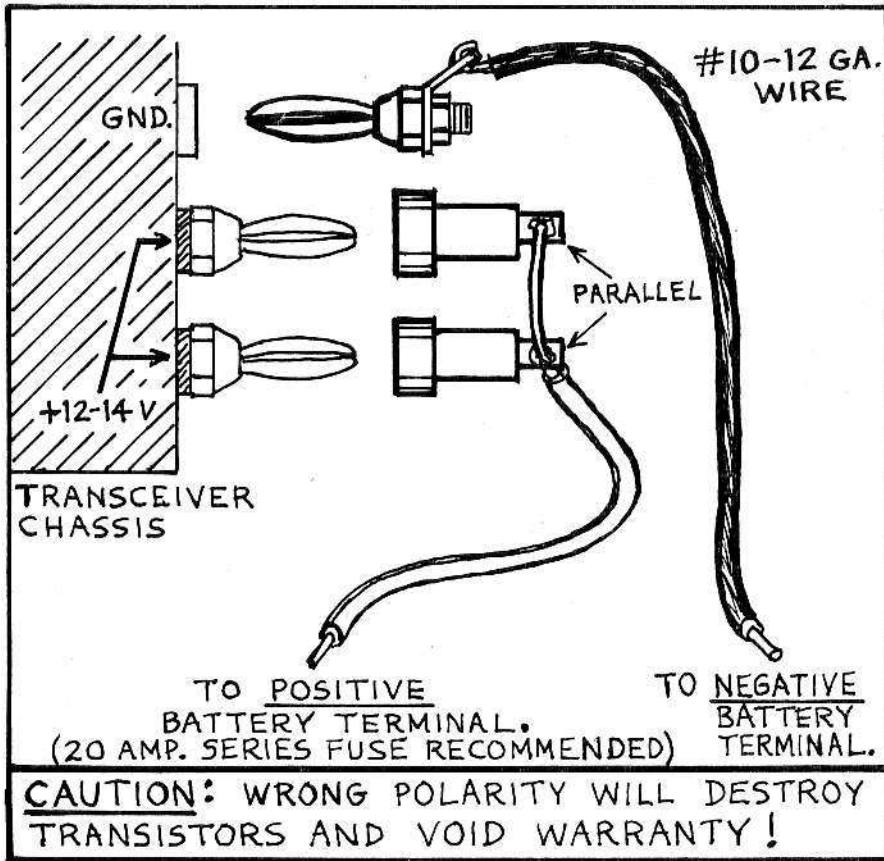

VOLTAGE CHARTS

- NOTES:**
- (1) No voltage. Near zero ohms to Gnd.
 - (2) RMS voltage measured with R.F. probe, bandswitch in 7 mc pos.
 - (3) Approx. RMS voltage with Mic. jack input of .03 volts at 1000 cycles, Mic. Gain at maximum clockwise.
 - (5) RMS voltage with R.F. probe, CW mode, Mic. Gain at max. clockwise.
 - (6) Full R.F. Gain, no signal input.

- * Measurements must be made with a meter having at least 10 megohms input resistance.
- * All D.C. voltages are designated by the + (positive) symbol.
- * Voltage figures not having the + symbol are RMS values of an A.C. voltage.

PC-100A PLUG-IN BOARD		
Term.Strip Number	REC.	TRANS.
1	(1)	(1)
2	Gnd.	Gnd.
3	Gnd.	Gnd.
4	0.6 (2)	1.15 (2)
5	Gnd.	Gnd.
6	Gnd.	Gnd.
7	∅	0.33 (3)
8	Gnd.	Gnd.
9	N.C.	N.C.
10	+13	+13
11	+13	+13
12	Gnd.	Gnd.
13	+11.8	+10.2
14	+7.3 (6)	+8.5 (6)
15	+2.8	+2.8
16	+2.8	+2.8
17	+13	+12.6
18	+13	+12.6
19	+3	+12.6
20	+13	∅
21	+3	+13
22	∅	+12.6

Q101	REC.	TRANS.
I.F. Amp.		
Base	+4.0 (6)	+5.1
Collector	+12.2 (6)	+9.4
Emitter	+3.4 (6)	+4.4

PC-400 VFO BOARD		
Q401 Base	+4	+4
Collector	+4.5	+4.5
Emitter	+3.5	+3.5
Q402 Gate	+5.2	+5.2
Source	+6	+6
Drain	+9.2	+9.2
Q403 Base	+4.3	+4.3
Collector	+6	+6
Emitter	+3.6	+3.6

PC-500 TRANSMIT AMPLIFIER		
Q501 Base	∅	+3.5
Collector	∅	+10.2
Emitter	∅	+2.8
Q502 Base	∅	+2.4
Collector	∅	+12.6
Emitter	∅	+1.5
Q503 Base	∅	+1.3
Collector	+15	+13
Emitter	∅	+3.5
Q504, Base	+4	+7
Q505 Coll.	+15	+13
Emitter	∅	∅
Q506 Base.	∅	+1.2
Collector	∅	+13
Emitter	+03	+7

PC-200 PLUG-IN BOARD		
Term.Strip Number	REC.	TRANS.
1	+13	+13
2	Gnd.	Gnd.
3	+3.6	+3.3
4	Gnd.	Gnd.
5	∅	∅
6	Gnd.	Gnd.
7	0.55 (2)	0.53 (2)
8	Gnd.	Gnd.
9	∅	0.27 (5)
10	Gnd.	Gnd.
11	∅	0.05 (3)
12	Gnd.	Gnd.
13	∅	0.33 (3)
14	∅	+6
15	Gnd.	Gnd.
16	∅	0.06 (3)
17	∅	∅
18	Gnd.	Gnd.
19	+3.5	+3.5
20	+2.6	+2.6
21	+10	+10
22	+2.6	+2.6

Q201, I.C.	REC.	TRANS.
I.F. Amp.		
Term.1-2-8	+10.4	+10.1
3-7	Gnd.	Gnd.
4	+0.39	+0.37
5	+0.45	+0.43
6	+0.38	+0.36

Q202, I.C.	REC.	TRANS.
Mic. Amp.		
Term.1-5	∅	+5.3
2-4-14	∅	+4.2
3	∅	+3.5
6	∅	+2.1
7	∅	+1.5
8	∅	+5.3
9	+3.4	+3.4
10	+2.7	+2.7
11	+9.8	+9.8
12	∅	+0.95
14	∅	+0.25

PC-600 CARRIER OSCILLATOR			
	REC.	TRANS.	CW
Q601 Base	+2.8	+2.8	+2.8
Collector	+9.3	+9.3	+9.3
Emitter	+3.2	+3.2	+2.5
Q602 Base	+6	+6	+7.5
Collector	+1.2	+4.5	+3.7
Emitter	∅	∅	∅

PC-800 CRYSTAL CALIB.		
Q801 Gate	-12 VDC (when crystal is oscillating)	
Source	∅	
Drain	+13	

CHASSIS:		
(10 volt Regulator)	Q1:Base	+10.2
	Collector	+13
	Emitter	+10

PC-300 PLUG-IN BOARD		
Term.Strip Number	REC.	TRANS.
1	∅	∅
2	Gnd.	Gnd.
3	∅	∅
4	+10	+10
5	∅	varies, ALC
6	+3.5	+3.5
7	Gnd.	Gnd.
8	2 VAC Max.	∅
9	Gnd.	Gnd.
10	+13	∅
11	∅	∅
12	Gnd.	Gnd.
13	.58 (2)	.55 (2)
14	Gnd.	Gnd.
15	.55 (2)	.53 (2)
16	Gnd.	Gnd.
17	.58 (2)	1.22 (2)
18	Gnd.	Gnd.
19	.58 (2)	1.18 (2)
20	Gnd.	Gnd.
21	+13	+13
22	(1)	+13

Q301, I.C.	REC.	TRANS.
A.F. Amp.		
Term.1-5	+6.7	-
2-4	+2.2	-
3	+1.5	-
6	+4.2	-
7	+3.5	-
8	+9.8	-
12	+1.9	-
13	+1.2	-
14	+12	-

Q302, I.C.	REC.	TRANS.
A.F. Amp.		
Term.1	+7	+0.6
2-3-4-5-7	} All Grounded	
9-10-11		
12-13		
6	∅	
8	+5.2	+1.8
14	+13	+13

Q303		
Gate	+0.7	+9
Source	+8.8	+8
Drain	+8.8	+8

Q304		
Gate	+9.8	∅
Source	+8.8	+8
Drain	+8.8	+8

Q305		
Gate	+9.4	∅
Source	+8.8	+8
Drain	+8.8	+8

Q306		
Gate	+0.7	+9
Source	+8.8	+8
Drain	+8.8	+8