

I. F. (AM) . . . . .	. . . . .	.455 kc.
I. F. (FM) . . . . .	. . . . .	10.7 mc.
Power Supply . . . . .	. . . . .	105-125 V. 60 cycles A.C.
Power Consumption . . . . .	. . . . .	180 watts.

**BUTTON SETTING:**

- TTONS  
FM  
ING
- Note - Insulate the muting switch springs before setting the AM buttons.
1. Select any one pushbutton.
  2. Pull translucent insert straight out.
  3. Insert screw driver blade through large hole of pushbutton into slot of locking screw. (See Fig. 1).
  4. Loosen locking screw about one-half turn. (Not more than one full turn.)
  5. With pushbutton depressed, carefully tune in desired station with the manual control and tighten the locking screw.

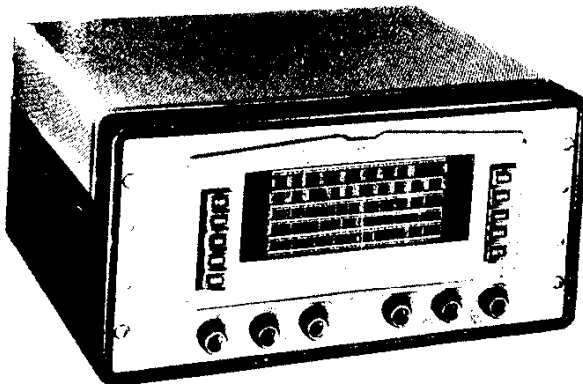

MODEL S-47

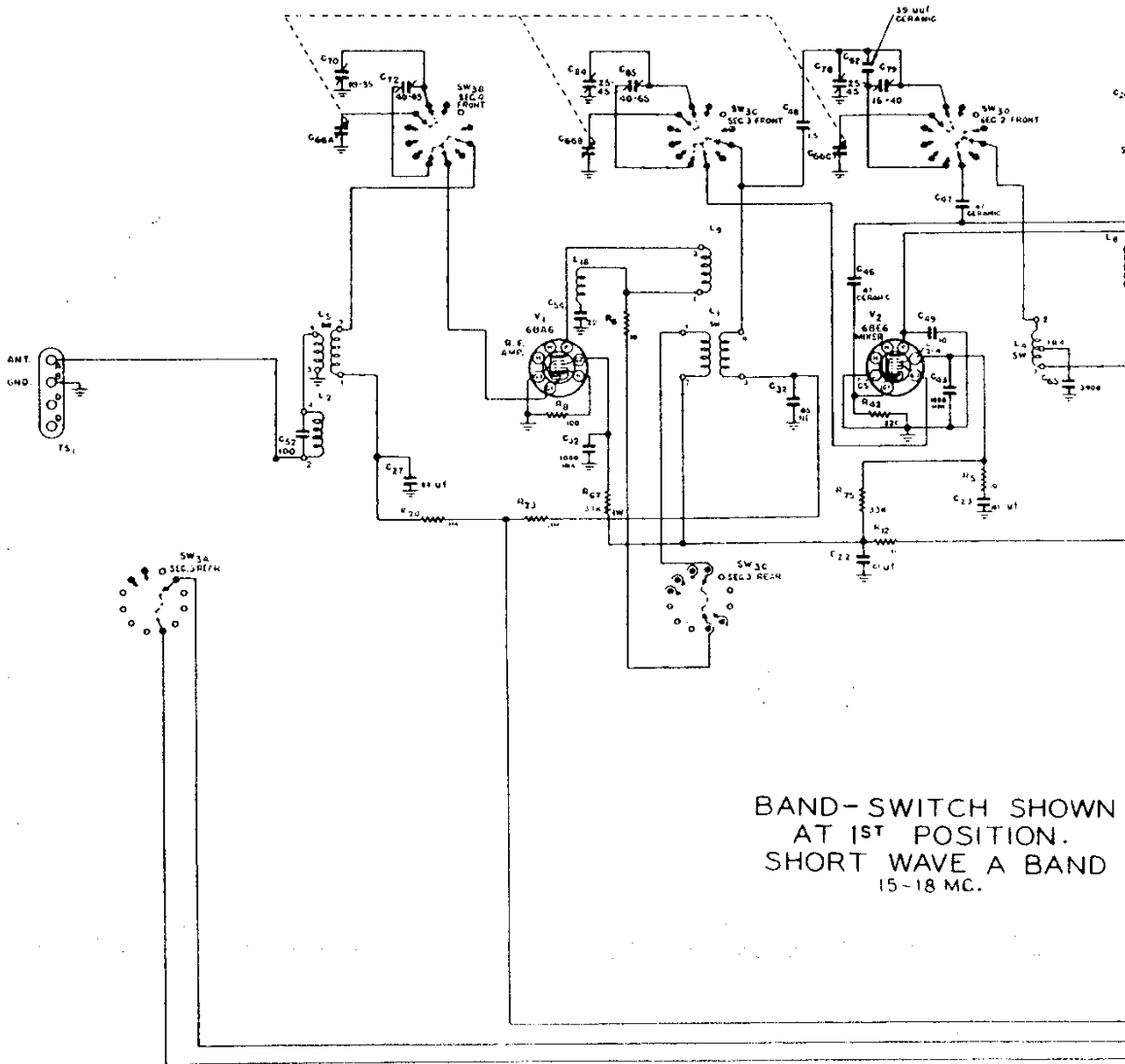

BAND-SWITCH SHOWN AT 1ST POSITION. SHORT WAVE A BAND 15-18 MC.

SERVICE PARTS LIST

REF. NO.	DESCRIPTION	HALLICRAFTERS' PART NUMBER
<b>CAPACITORS</b>		
C-1, 3, 4, 5, 6, 8, 9, 12, 13, 14, 15, 16, 17, 18, 20, 21, 22, 23, 24, 35, 90	.01 mfd 600 v., tubular paper	46A7103F
C-2, 26, 27, 28	.02 mfd 600 v., tubular paper	46AY203F
C-7, 11, 31, 32, 50, 51	.05 mfd 600 v., tubular paper	46AY503F
C-25	.01 mfd 600 v., molded paper	46AG103J
C-30	.1 mfd 200 v., tubular paper	46AU104H
C-33	.005 mfd 600 v., tubular paper	46AZ502J
C-34	.003 mfd 600 v., tubular paper	46AZ302J
C-36	60-20 mfd 450 V., 20 mfd. 30 v. electrolytic	45B099
C-37	40-10 mfd 450 V., 20 mfd. 30 v., electrolytic	45B100
C-38, 39	500 nmf 50 v.	
C-40, 42, 43, 44	10,000 nmf 50 v.	
C-41	100 nmf 50 v.	
C-45	10 nmf 50 v.	
C-46, 47	47 nmf 50 v.	
C-48	1.5 nmf. 50 v.	
C-49	10 nmf 50 v.	
C-52, 64	100 nmf 50 v.	
C-54	22 nmf 50 v.	
C-55	22 nmf 50 v.	
C-56, 57, 58	220 nmf 50 v.	
C-59	330 nmf 50 v.	
C-60, 61, 62	47 nmf 50 v.	
C-63	.001 mfd 50 v.	
C-65	.0039 mfd 50 v.	
C-66	Tuning cond.	
C-67	Tuning cond.	
C-68	570 nmf. 50 v.	
C-69, 70, 71, 72, 73, 74	Trimmer cond. stage.	
C-75	Trimmer, 50 v.	
C-76	Trimmer, 50 v.	
C-77, 78, 79, 80, 81, 82	Trimmer, 50 v. stage.	
C-83, 84, 85, 86, 87, 88	Trimmer, 50 v. stage.	

T S A

1

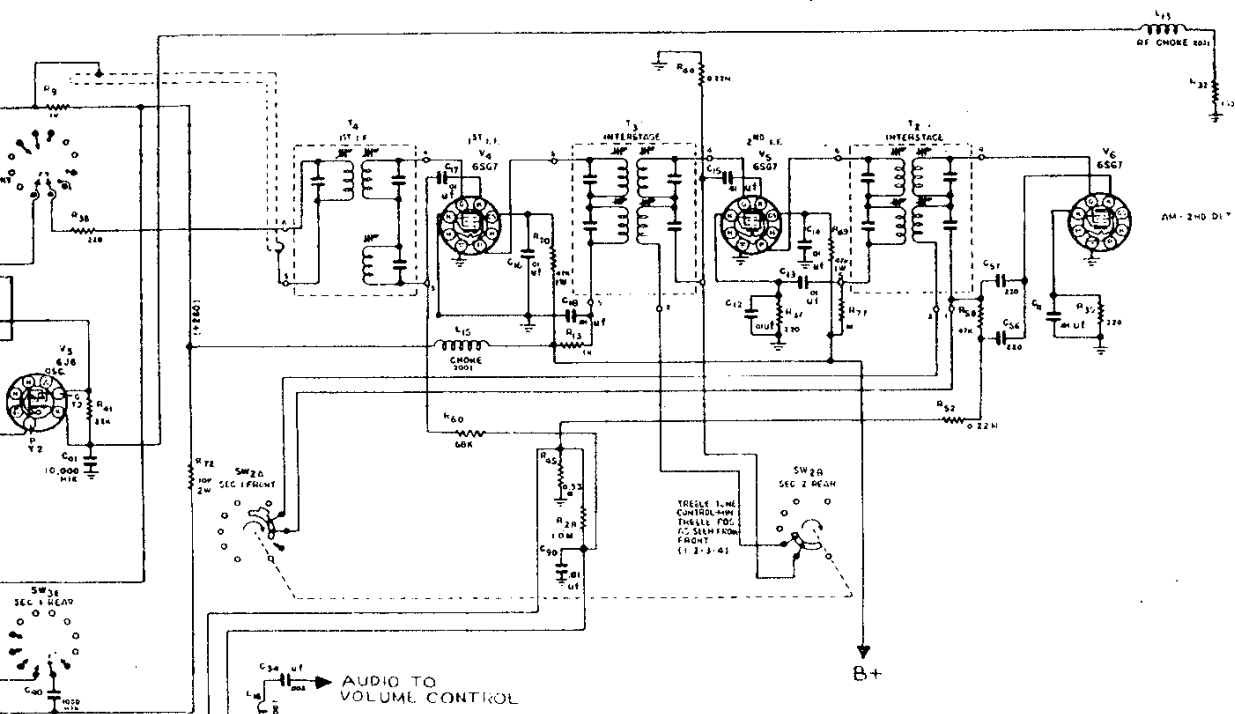

- v., ceramic 47A147
- v., ceramic 47A148
- 50 v., ceramic 47B32103N1
- ., ceramic 47A149
- ., ceramic 47A150
- amic 47A160-3
- ., mica CM20A100K
- v., mica CM20A101M
- ., mica CM20A220K
- ., mica CM20A221M
- v., mica CM20A221M
- v., mica CM20A331M
- v., mica CM20A470M
- v., mica CM30A102M
- 00 v., mica CM35A392J
- user, "AM" 48C176
- user, "FM" 48C175
- mer. 44A189
- ntly, ant. 44B190
- mixer stage. 44A192
- ant. stage. 44A194
- ntly, osc. 44B195
- ntly, mixer 44H196

- C-89 Trimmer, FM, osc. stage 44A218
- C-92 39 mmf. 500 V., ceramic CC30SH390M

**RESISTORS**

- R-1,2 330 ohms 5 watts, WW. 24AB64
- R-3 47 ohms 4 watts, Carbon. RC20AE470M
- R-4 2 meg-ohms, volume control 25A685
- R-5, 6 10 ohms 1/2 watt, carbon RC20AE100M
- R-7, 49 33,000 ohms 1/2 watt, carbon RC20AE333M
- R-8 100 ohms 1/2 watt, carbon RC20AE101M
- R-9, 10, 12, 13, 14, 77 1000 ohms 1/2 watt, carbon RC20AE102M
- R-15, 16 10,000 ohms 1/2 watt, carbon RC20AE103M
- R-17, 19, 20, 21, 22, 23, 24 100,000 ohms 1/2 watt, carbon RC20AE104M
- R-18 33 ohms 1/2 watt, carbon RC20AE330M
- R-26, 27, 28, 29, 30, 31 1 meg-ohm 1/2 watt, carbon RC20AE105M
- R-32 150 ohms 1/2 watt, carbon RC20AE151M
- R-33, 34 100,000 ohms 1/2 watt, carbon RC20AE104K
- R-35, 36, 37, 38, 39 220 ohms 1/2 watt, carbon RC20AE221M
- R-40, 58, 59 47,000 ohms 1/2 watt, carbon RC20AE473M
- R-41, 42, 79 22,000 ohms 1/2 watt, carbon RC20AE223M
- R-43, 44, 52, 64 220,000 ohms 1/2 watt, carbon RC20AE224M
- R-45, 50, 51 330,000 ohms 1/2 watt, carbon RC20AE334M
- R-46 100 ohms 1/2 watt, carbon RC20AE101K
- R-47, 48 3300 ohms 1/2 watt, carbon RC20AE332M
- R-53 3900 ohms 1/2 watt, carbon RC20AE392K
- R-54 12,000 ohms 1/2 watt, carbon RC20AE123K
- R-55 470 ohms 1/2 watt, carbon RC20AE471M
- R-56 4700 ohms 1/2 watt, carbon RC20AE472M
- R-57 820 ohms 1/2 watt, carbon RC20AE821K
- R-60, 61 68,000 ohms 1/2 watt, carbon RC20AE683K
- R-62, 65 470,000 ohms 1/2 watt, carbon RC20AE474M
- R-63 390,000 ohms 1/2 watt, carbon RC20AE394K
- R-66 100,000 ohms 1 watt, carbon RC30AE104M
- R-67 33,000 ohms 1 watt, carbon RC30AE333M
- R-68, 69, 70 47,000 ohms 1 watt, carbon RC30AE473M
- R-71 22,000 ohms 1 watt, carbon RC30AE223M
- R-72, 73, 74 10,000 ohms 2 watt, carbon RC40AE103M



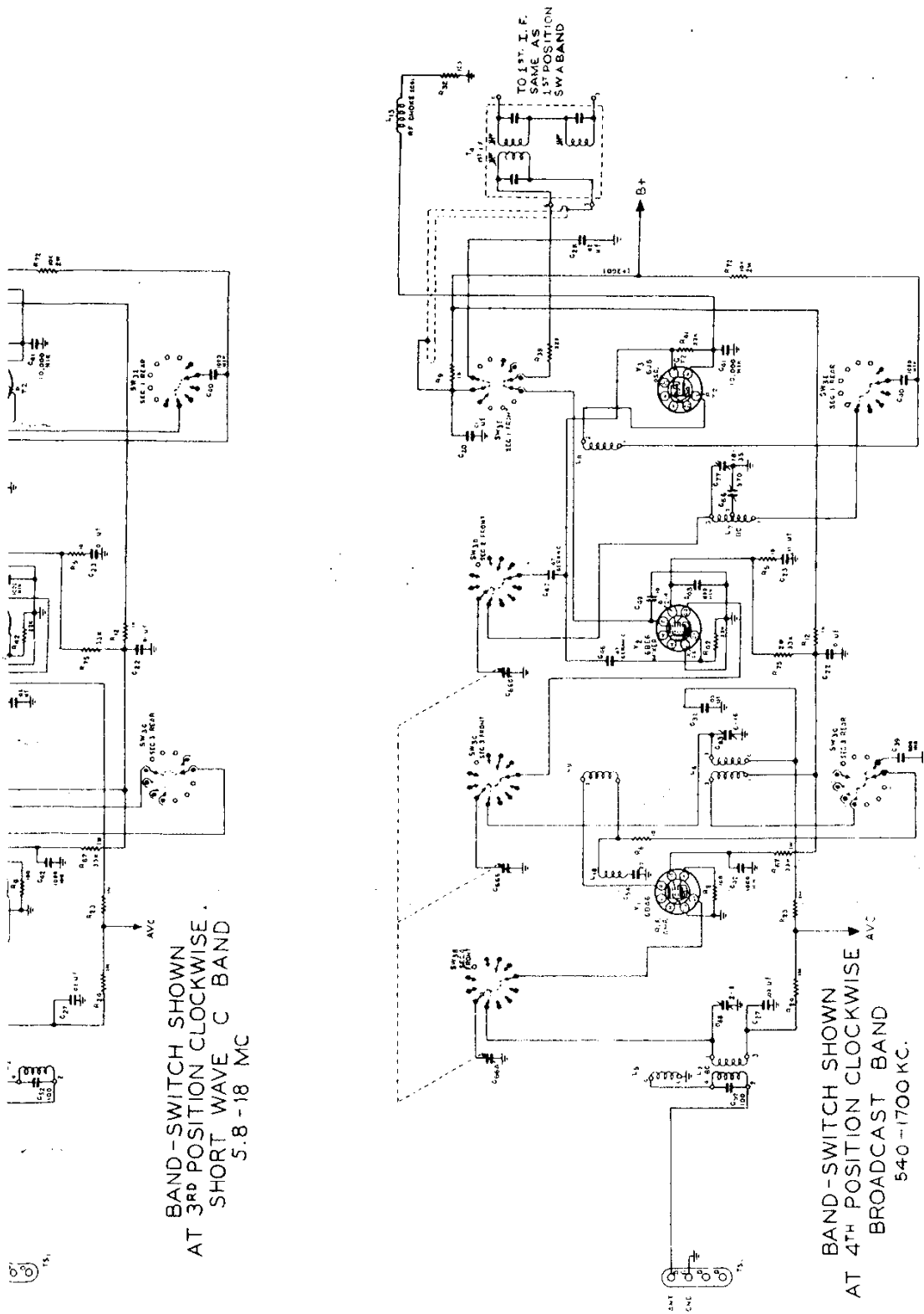

BAND-SWITCH SHOWN  
AT 3RD POSITION CLOCKWISE  
SHORT WAVE C BAND  
5.8 - 18 MC

BAND-SWITCH SHOWN  
AT 4TH POSITION CLOCKWISE  
BROADCAST BAND  
540 - 1700 KC.

MODEL S-47

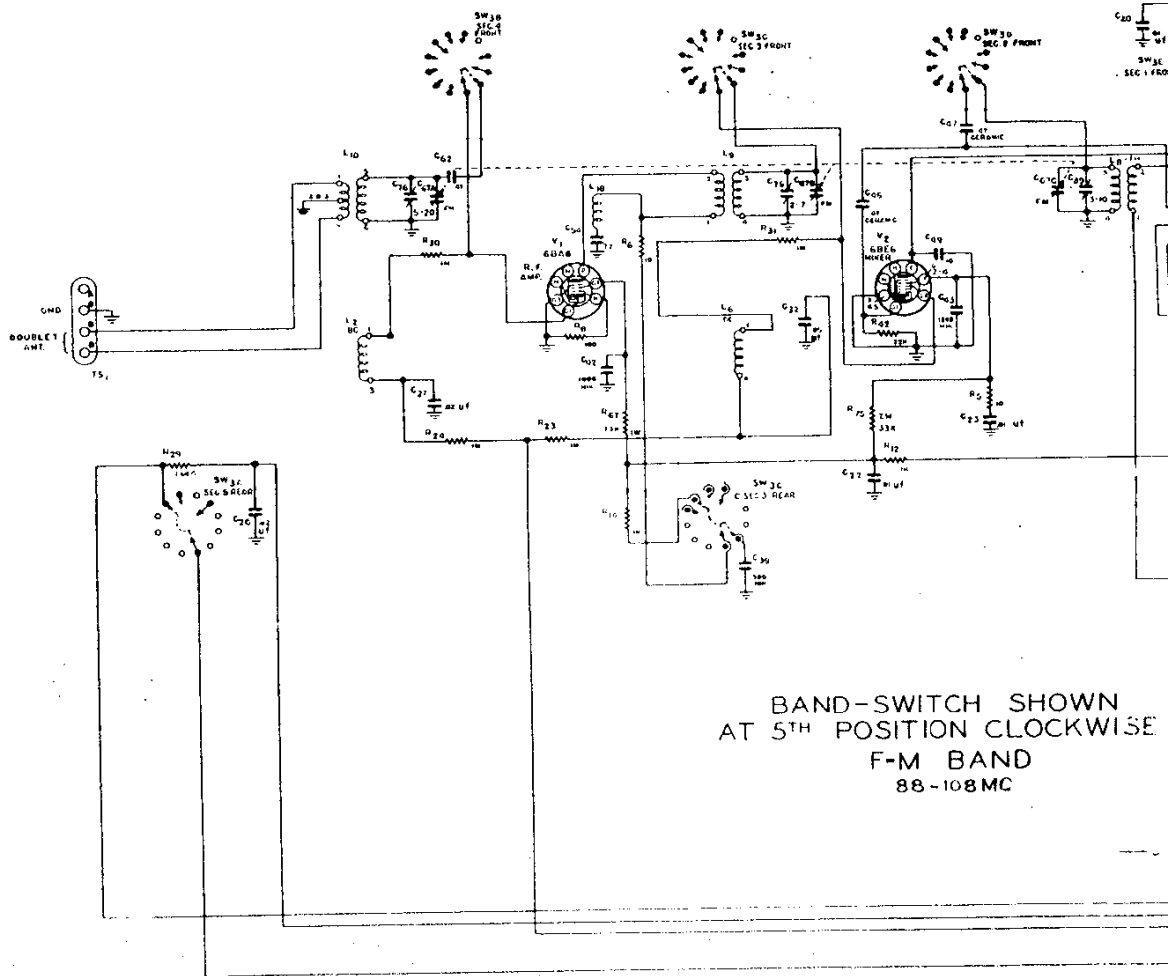

BAND-SWITCH SHOWN AT 5<sup>TH</sup> POSITION CLOCKWISE  
F-M BAND  
88-108 MC

SERVICE PARTS LIST (Continued)

REF NO	DESCRIPTION	HALLICRAFTERS PART NUMBER		
<b>RESISTORS (Continued)</b>				
R-75	35,000 ohms 2 watts, carbon	RC40A133F	L-13, 14, 15, 16	R.F. choke
R-76	330 ohms, plug-in ballast	24RB7C	L-18	R.F. choke, 1000
R-79	470 ohms 2 watts, carbon	RC40AE471M	L-21	Audio choke
<b>TRANSFORMERS AND COILS</b>				
T-1	Transformer, FM detector	50C208		
T-2, 3	Transformer, interstage I.F.	50C209		
T-4	Transformer, 1st. I.F.	50C210		
T-5	Transformer, power	52C151		
T-6	Transformer, audio output	55B096		
L-1	Mixer coil for SW band	51B905	SW-1	Power & Bass
L-2	Antenna coil for BC band	51B955	SW-2	Treble switch
L-3	Oscillator coil for SW band	51B908	SW-3	Band switch
L-4	Antenna coil for SW band	51B909	SW-4	Muting switch
L-5	Mixer coil for BC band	51B910		
L-6	Oscillator coil for BC band	51B911		
L-7	Oscillator coil for FM band	51B914		
L-8	Mixer coil for FM band	51B915		
L-9	Antenna coil for FM band	51B916		
L-10	Plate choke, osc. stage	53B008	V-1	Type 6BA6, A
L-11	Filament choke	53B009	V-2	Type 6BE6, M
				<b>PLUGS AND JACKS</b>
			PL-1	Line cord and
			S0-1	Receptacle,
			S0-2	Jack, phono
			S0-3	Receptacle, 1/4"
				Socket, octal
				Socket, 9-pin
				Pilot light
				L.H.
				Pilot light
				R.H.
				<b>TUBES AND</b>

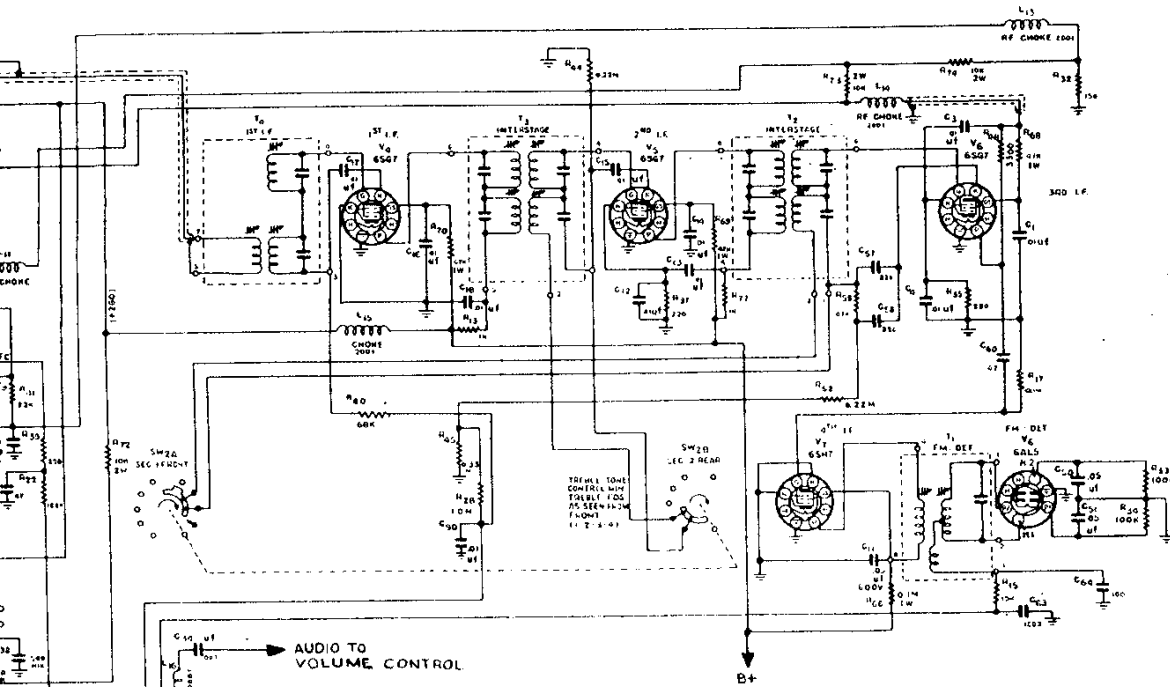

Page plate 53A106  
53A115  
56B082

Switch ass'y 60B307  
60B264  
60C266  
18A092

MPS  
87B1625  
Motor 10A015  
36A034  
6A190  
6A190  
(tube) 6A276  
& bracket, 86A046  
& bracket, 86A047

ETS  
90X6BA6  
90X6BE6

V-3	Type 6J6, Oscillator and A.F.C.	90X6J6
V-4, 5, 6	Type 6SG7, I.F. amplifier	90X6SG7
V-7	Type 6SH7, I.F. amplifier	90X6SH7
V-8	Type 6AL5, F.M. detector	90X6AL5
V-9, 10	Type 6J5, A.F. amplifier	90X6J5
V-11, 12	Type 6SQ7, Phase inverter	90X6SQ7
V-13, 14	Type 6V6GT/G, A.F. power amplifier	90X6V6GT
V-15	Type 5U4G, Rectifier	90X5U4G
LM-1, 2	Lamp, 6-8 V., 150 MA. G.E. #47	39A004

**MISCELLANEOUS COMPONENTS**

Shield base, tube (miniature tube)	69A169
Shield, tube (miniature tube)	69A104
Spring, tube retainer	75A076
Carriage, pointer	67B645
Pointer, FM	82B138
Pointer, AM	82B143
Spring, pointer	75A132
Push-button (black)	17B028-1
Insert, push-button, lucite	17A027
Insert, push-button, metal	17A029
Call letters	17A025-1
Spring, dial	75A006
Cord, dial	38A017
Escutcheon	7D039-1
Dial glass, upper	22B184
Dial glass, lower	22B193
Knob	15A131
Terminal strip, antenna	88A277
Terminal strip, speaker	88A334-1
Shield, speaker terminal	69C173

TS-1  
TS-2

THE HALLICRAFTERS CO.

MODEL S-47

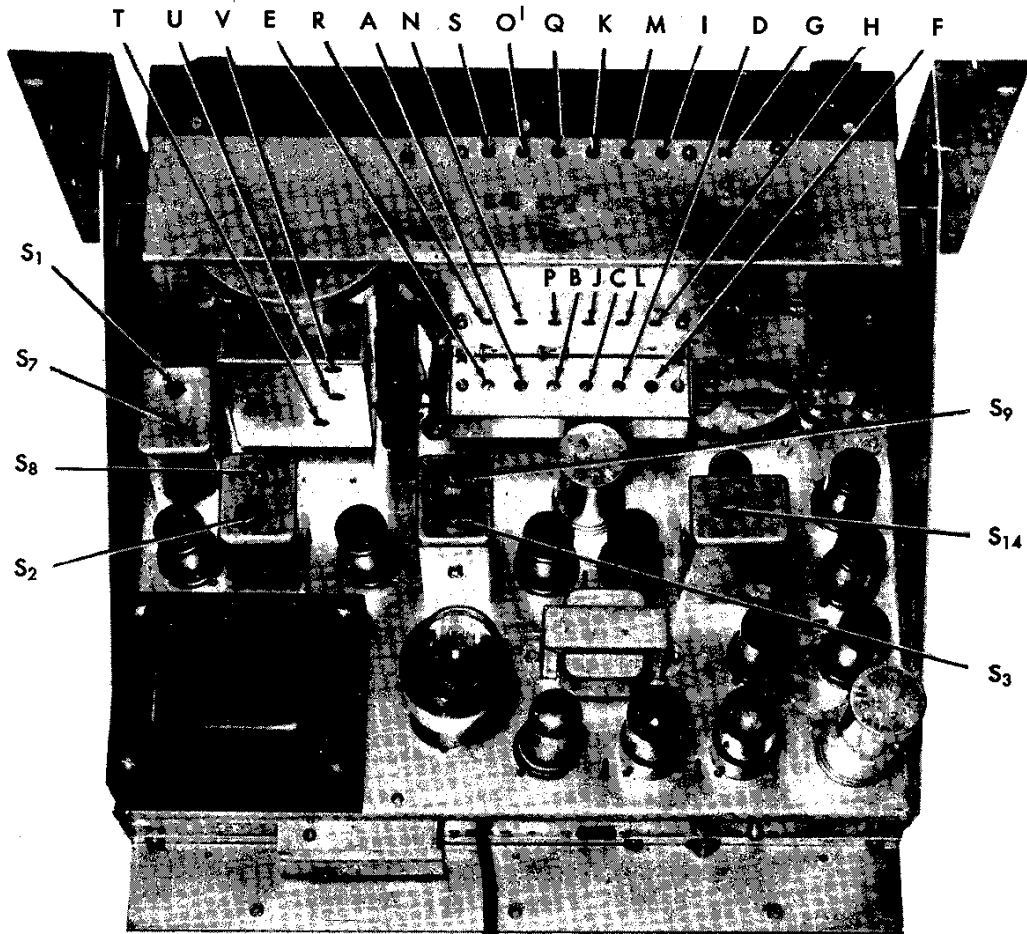

Top view showing alignment points.

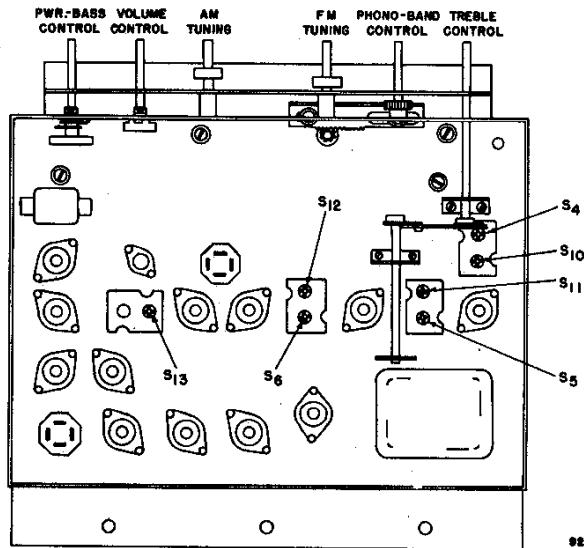

Fig. 5. Bottom view showing alignment points.

**REPLACING DIAL LAMP:**

Refer to FIG. 10 for location of the two pilot lamps. To gain access to the lamps remove the four front panel screws holding the panel to the cabinet and three chassis screws located under the cabinet. Pull the chassis clear of the cabinet. Unfasten and remove the knobs. Remove the four panel screws holding the panel to the chassis to release the panel exposing the pilot lamps for service. Replace pilot lamps with 6-BV, 150 Ma. Mazda #47 equivalent.

**ALIGNMENT PROCEDURE:**

It will be necessary to remove the receiver chassis from the cabinet and remove the chassis bottom plate to gain access to some of the I. F. transformer iron core adjustments. See Fig. 5.

The receiver is equipped with AUTOMATIC FREQUENCY CONTROL on the "FM" band to compensate for mechanical variations in the push-button mechanism. Correction factor is approximately 5 times. "Take hold" characteristics are: "Before" 100 kc and "Release" before 450 kc at a 0.2 volt input signal.

The standard RMA dummy mentioned in the alignment chart consists of a 200 muf condenser in series with a 20 oh r-f choke which is shunted by a 400 muf condenser in series with a 400 ohm carbon resistor.

**ALIGNMENT PROCEDURE**

Step	Dummy Antenna	Signal Generator Coupling	Signal Generator Frequency	Band Switch Pos.	Radio Dial Setting	Adjust	Remarks
1	0.01 mfd cap.	To stator plates of center section of AM tuning cap.	455 kc	"BC"	1000 kc	S5, S6, S2, S5, S1 & S4	Adjust for max. output. TREBLE tone control set at No. 1.
2	0.01 mfd cap.	To stator plates of center section (No modulation)	10.7 mc	"FM"	Mid-scale	S9, S12, 13, S8, S11, S7 & S10	Adjust for max. AVC voltage as measured between pin #7 of 6AL5 and ground with a 20,000-ohm per volt meter.
3	0.01 mfd cap.	To stator plates of center section (No modulation)	10.7 mc	"FM"	Mid-scale	S14	Adjust for zero voltage as measured between junction of L18 and C24 with a 20,000-ohm per volt meter.
4	Std. RMA dummy.	To terminals "A" and "G" on ant. term. strip	1500 kc 600 kc	"BC" "BC"	1500 kc 600 kc	F*, H and I G*	Adjust for max. output
5	Std. RMA dummy	To terminals "A" and "G" on ant. term. strip	16 mc	"C"	16 mc	E*, R and S	Adjust for max. output.
6	Std. RMA dummy	To terminals "A" and "G" on ant. term. strip.	18 mc 15 mc	"A" "A"	18 mc 15 mc	A*, O and N B*, P, and Q	Adjust for max. output
7	Std. RMA dummy	To terminals "A" and "G" on ant. term. strip.	12 mc 9 mc	"B" "B"	12 mc 9 mc	C*, J and K D*, L	Adjust for max. output.
8	Two 150 ohm carbon resistors	To terminals "D" and "D" on ant. term. strip; one 150 ohm resistor in each lead.	108 mc	"FM"	108 mc	T*, U and V	Adjust for max. output.

\* NOTE - Calibration adjustments.

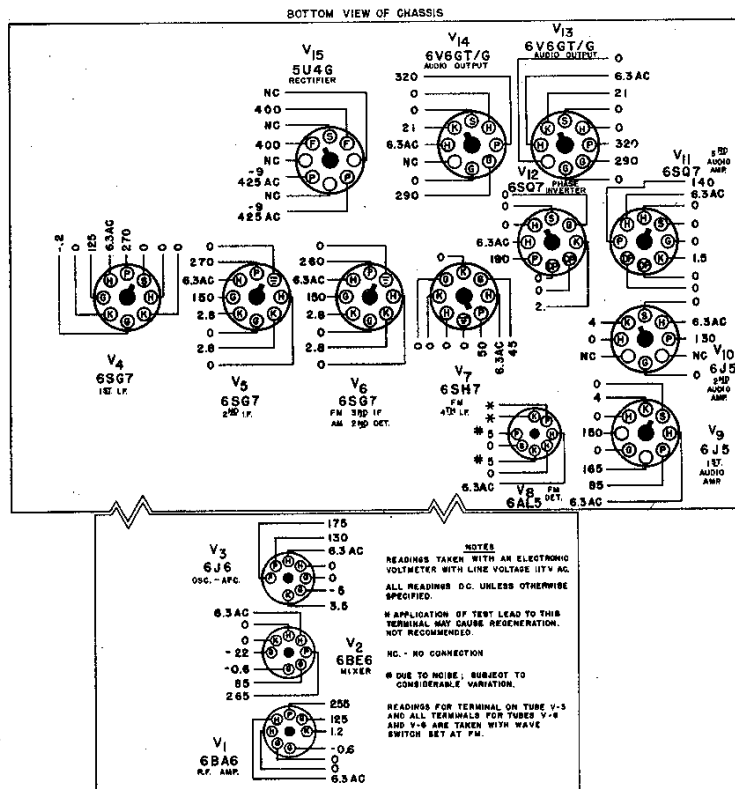

Tube voltage chart.

THE HALLICRAFTERS CO.

MODEL S-47

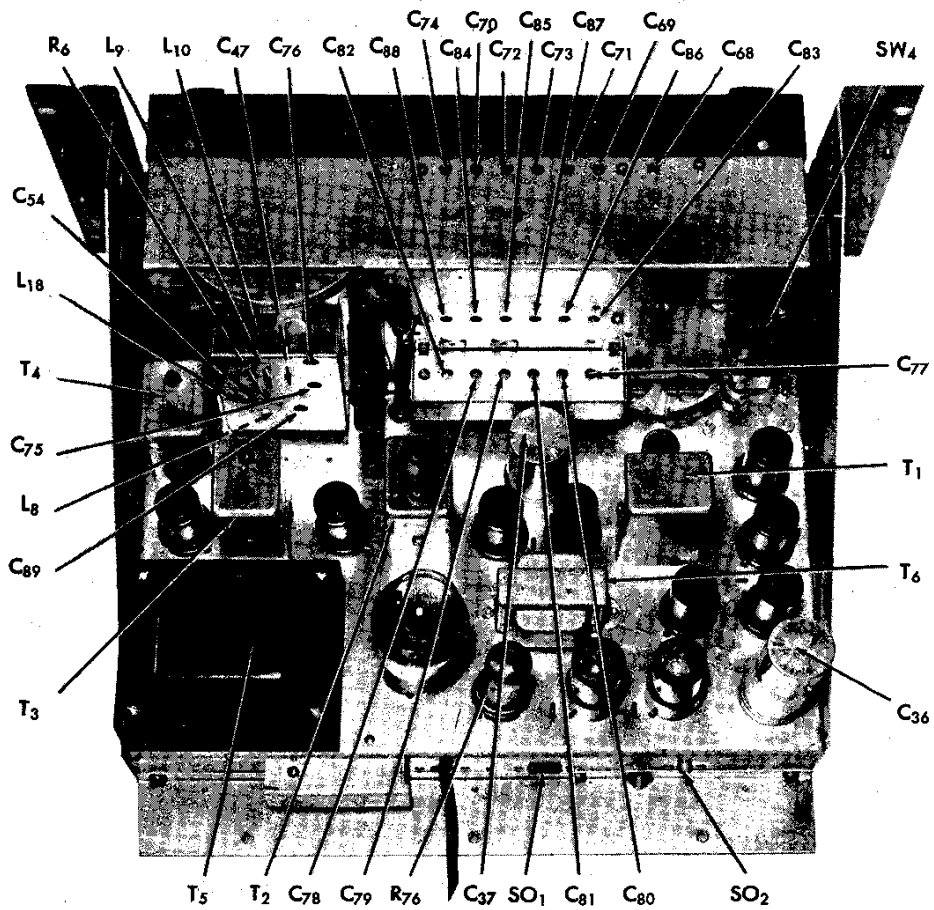

Top view showing component location.

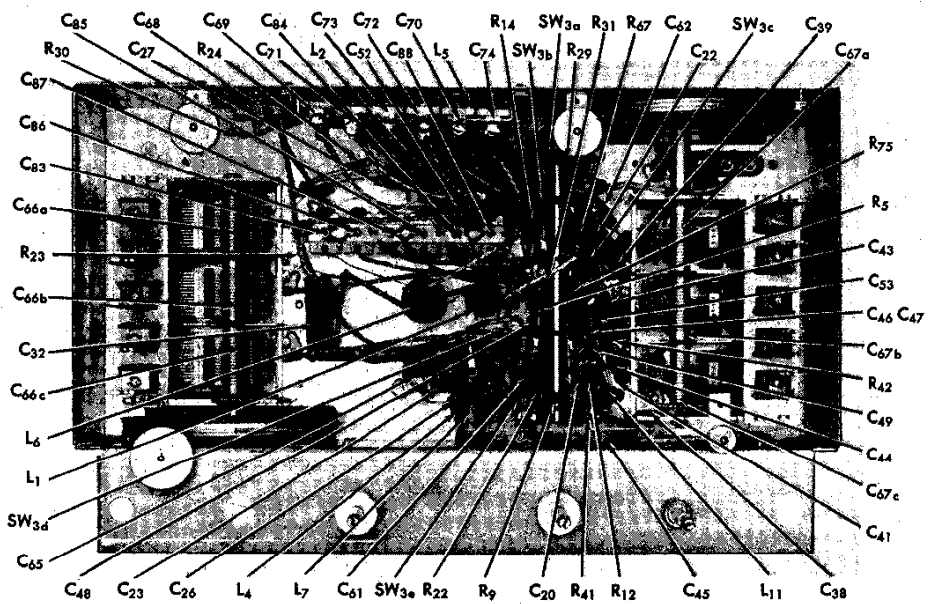

Front view of R.F. chassis showing component location.

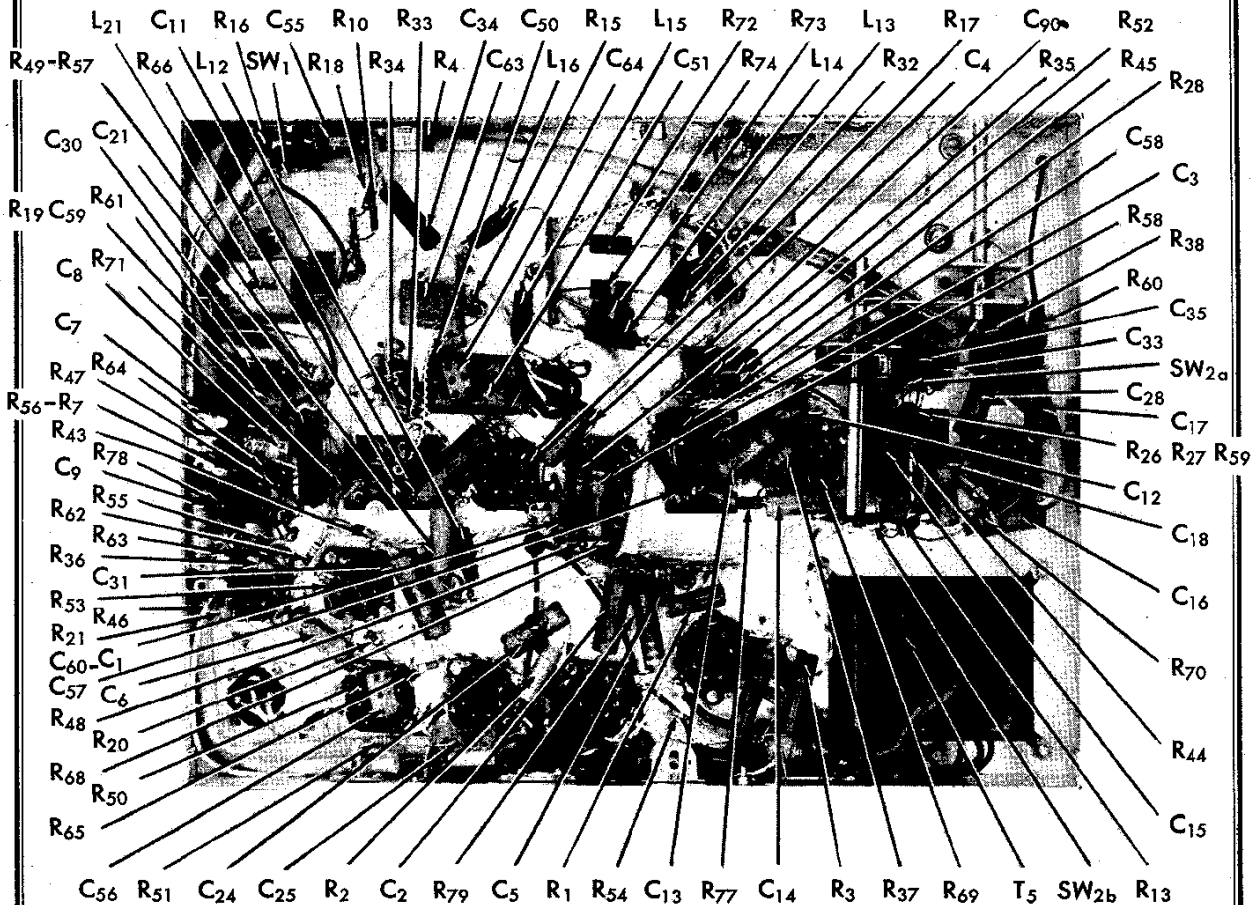

Bottom view of receiver showing component location.

**INSERTING CALL LETTERS INTO TRANSLUCENT INSERT ASSEMBLY:**

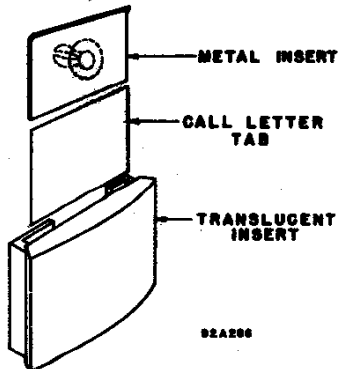
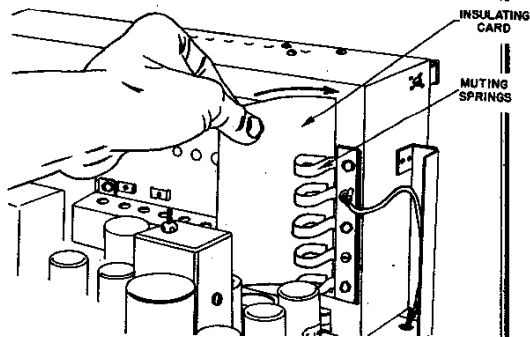
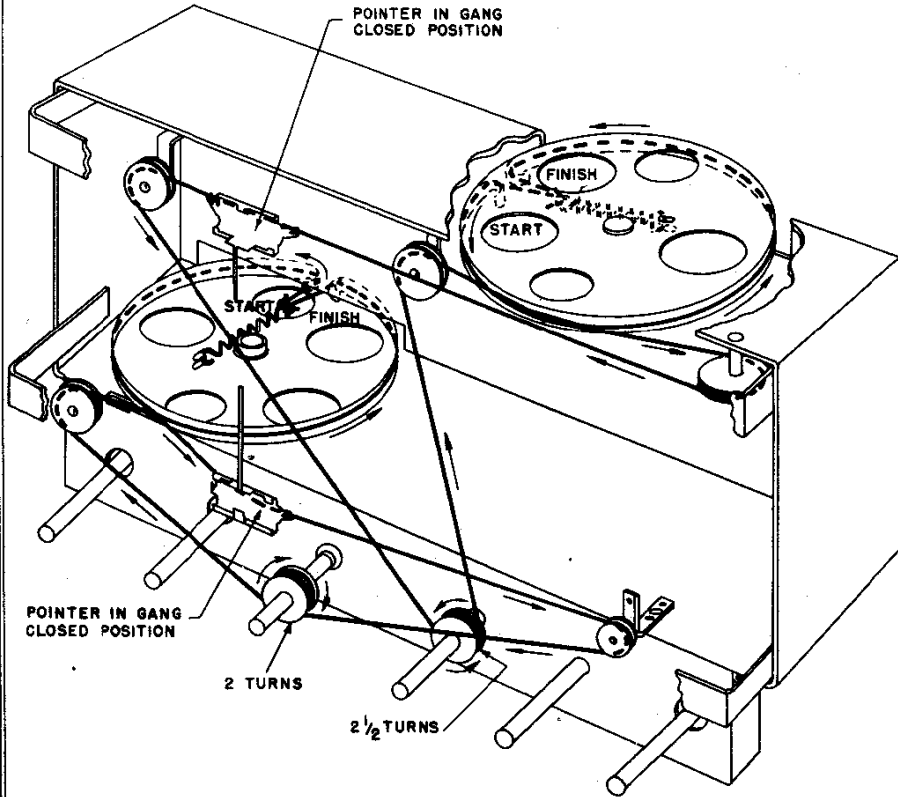

Fig. 2. View showing call letter installation.

1. Slide out metal insert from translucent insert assembly. (See Fig. 2).
2. Insert call letter tab.
3. Replace metal insert.
4. Replace translucent insert assembly into push-button.



Insulating the muting switch contacts



Dial cable stringing procedure.

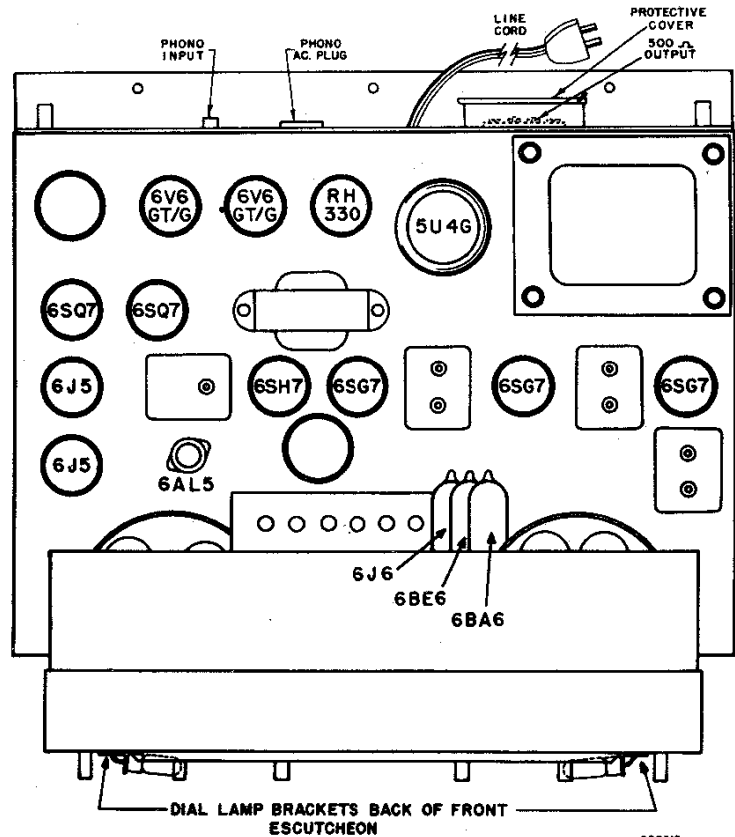

Top view, location of tubes and dial lamps.