

ILER-40 AGC "ADD-ON" MINI-MODULE

Last review November 1, 2012

ea3gcy@gmail.com

Latest updates and news: www.qsl.net/ea3gcy

PLEASE READ ALL INSTRUCTIONS COMPLETELY AT LEAST ONCE BEFORE STARTING.

Installation

- 1) Prepare two 8-pin strips as described in "INSTALLING THE AGC BOARD ON ILER".
- 2) Remove R17 and C31 ILER board (or cut one end of each component above the plate).
- 3) Remove IC4 (LM714 preamp audio) from its socket on ILER board
- 4) Mount AGC board following the parts list and the drawing board. All resistors are arranged vertically except R1.

Place the electrolytic capacitor and the diodes D1 and D2 (Observe correct polarity!)

All transistors are the same, place according to the PCB silkscreen.

Place strip of two terminals at the marked "V" on the board.

Put the wire bridge located in the drawing below D1.

- 5) Install two terminal strips of 8 extra long "wire-wrap connectors" on AGC board . This will be plugged into the socket IC4 of ILER now empty (see "INSTALLING THE AGC BOARD ON TO ILER BOARD").

- 6) Insert the module into the socket IC4.

- 7) **Make sure the AGC module is high enough and does not touch any part of ILER.**

- 8) You can now start the transceiver.

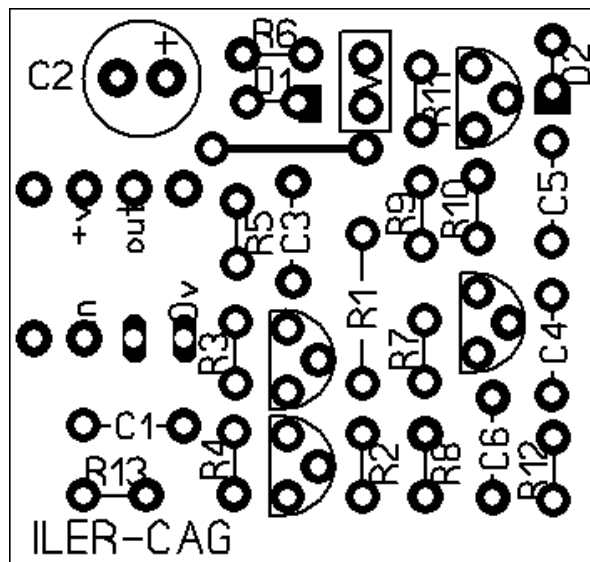

IMPORTANT:

* R13 4K7 can be any value between 1K and 10K. This resistor adjusts the audio level sent to the volume pot and IC5 LM386 power amplifier.

I recommend 3K3 or 4K7 but you can decrease or increase the value for a range of volume without distortion and that suits your hearing.

Notes:

- The IC4 (LM741) of ILER is not used because the AGC circuit also functions as audio preamplifier.
- Board measurements are 30x28, 5mm
- The terminals marked V-CAG can be used to activate an **s-meter**. Be careful, a meter can degrade the performance of AGC! The meter must be high impedance because it is in parallel with R11 and affects actions of Q3 and Q4. Place a 47K potentiometer in series with meter and adjust the value until 3/4 of the scale indicates strong signals. In the absence of signal, the S-meter indicates a certain deflection caused by the voltage drop across R11 of about 3v. If desired to remove this offset you could place in series with R11 ,a zener diode (2V7 or 3V3.)

Schematic . How does it work?

The AGC circuit is very simple, but very effective.

This same circuit is being used with the famous transceiver assembly called "BitX" by Farhan Ashhar VU2ESE, which has been modified by many fans.

The AGC is a feedback signal which causes the output to remain stable even if the input signal level changes.

In very few words, the signal is amplified by Q1, Q3 and is passed on. Furthermore, the signal Q4 also conducts more or less depending on the level of signal that arrives, therefore, the voltage at its collector will vary. This voltage, through R6, D1 and the time constant set by C2 makes the drive more or less to Q1 collector and Q2 base.

Q2 is placed in series with the emitter of Q1 and controls the gain thereof.

The feedback is that: if more signal arrives at Q4 this conducts more and there is less strain on your collector, this variation drives less and makes Q2 and Q1 amplify less and vice versa.

Thanks to Alfons EA3BFL and Lluís EA3WX for your help in building and testing prototypes to complete this circuit. And Pete G4HAK for the English translation of this document.

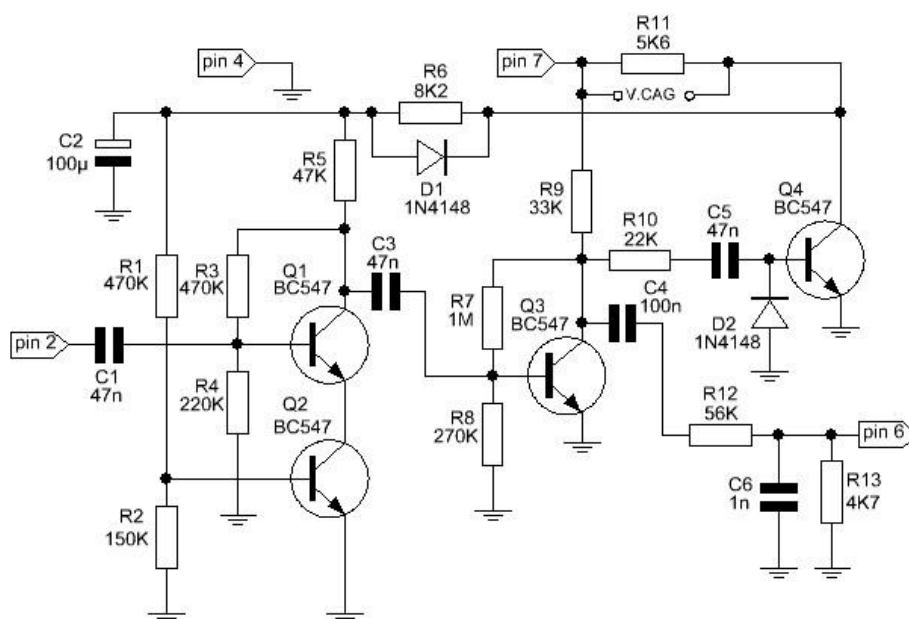

Components list

Resistors				
Qty	Type	Checked	Ref.	Identified
1	1M		R7	brown-black-green
2	470K		R1, R3	yellow-violet-yellow
1	270K		R8	red-violet-yellow
1	220K		R4	red-red-yellow
1	150K		R2	brown-green-yellow
1	56K		R12	green-blue-orange
1	47K		R5	yellow-violet-orange
1	33K		R9	orange-orange-orange
1	22K		R10	red-red-orange
1	8K2		R6	gray-red-red
1	5K6		R11	green-blue-red
1	4K7		R13 *	yellow-violet-red

Capacitors				
Qty	Type	Checked	Ref.	Identified
1	1n		C6	102 or 0.001
3	47n		C1, C3, C5	473 or 0.047
1	100n		C4	104 or 0.1
1	100uF		C2	100uF 25 or 35V

Semiconductors				
Qty	Type	Checked	Ref.	Identified
4	BC547/BC238		Q1, Q2, Q3, Q4	BC547/BC238
2	1N4148		D1, D2	1N4148

Miscellaneous				
Qty	Type	Checked	Ref.	Identified
3	--		3 pin strip of 4 (1 strip extra for reserve)	--
1	--		1 pin strip of 2 pins for "V"(v-cag) terminal	--
1	--		IC Socket 8 pin	--

INSTALLATION AGC Board IN ILER

Option 1.

Pin strips are inserted directly into the IC4 socket on the ILER Board.

Note that This will prise open the IC4 socket as the pins are thicker than those of an integrated circuit. Consequently you might need to replace this if you ever wanted to insert the original IC. (Unlikely since the AGC board works better!)

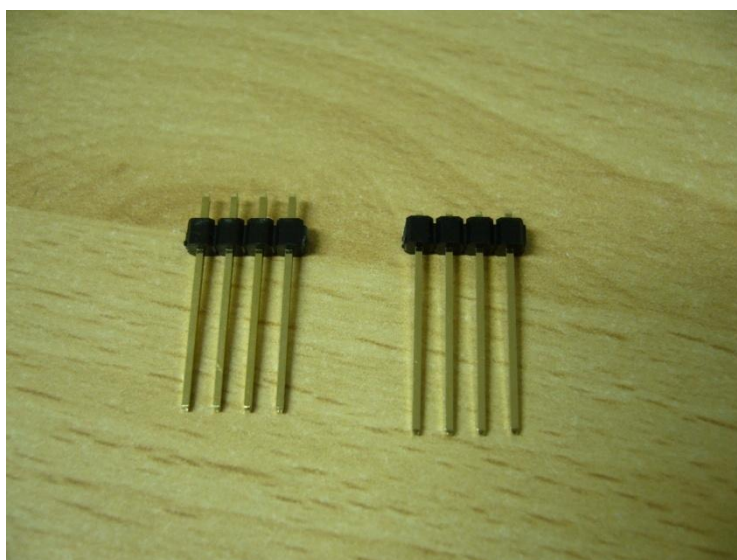

(1) Before fitting the pins to the board push or the pins need to look like the picture on the right. (Longer pins) (see (2) below)

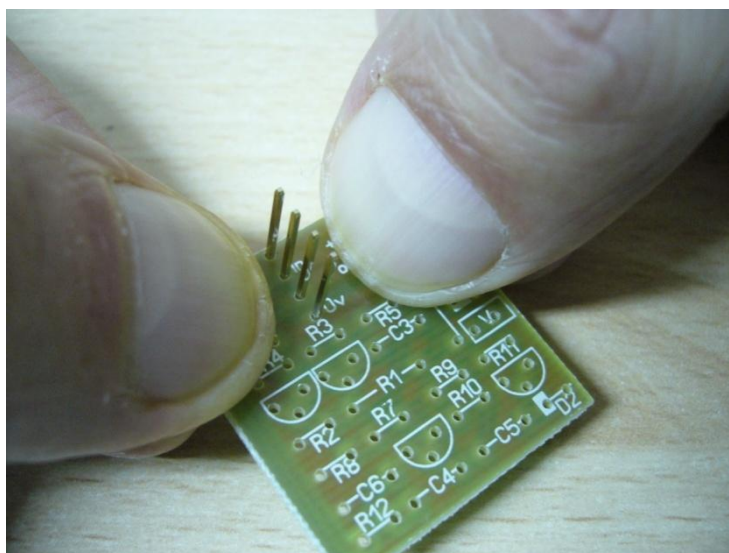

(2) To change the length of the terminals:

Place strips (one to one) in the board and push slowly on a table or hard surface to move the plastic strip until the long side of the terminals are slightly longer (about 15mm).



(3) After changing the pin strips should be about 15mm in length.

Option 2.

Pin strips are inserted in a socket formed with a set of pins and strips on the AGC board. The legs of this socket can be inserted into the socket IC4 (a pedestal above the other). This system does not spoil the original socket IC4 and allows you to replace the original IC4 if required.

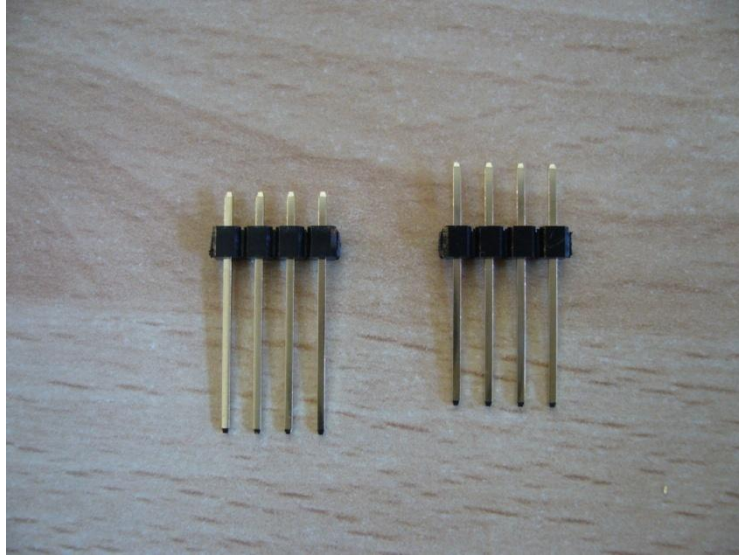

- (1) The strip on the left is the original and the right is modified and is as it should be before soldering (has shortened the long side).

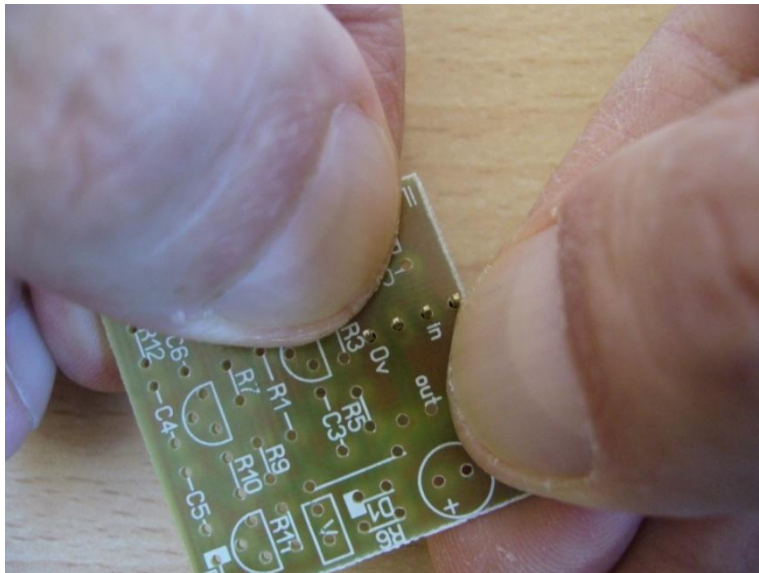

- (2) To change the length of the terminals:
Place one of the strips (one to one) in the boards and push slowly on a table or hard surface to move the plastic strip until the long side of the terminals are slightly shorter (about 12mm).

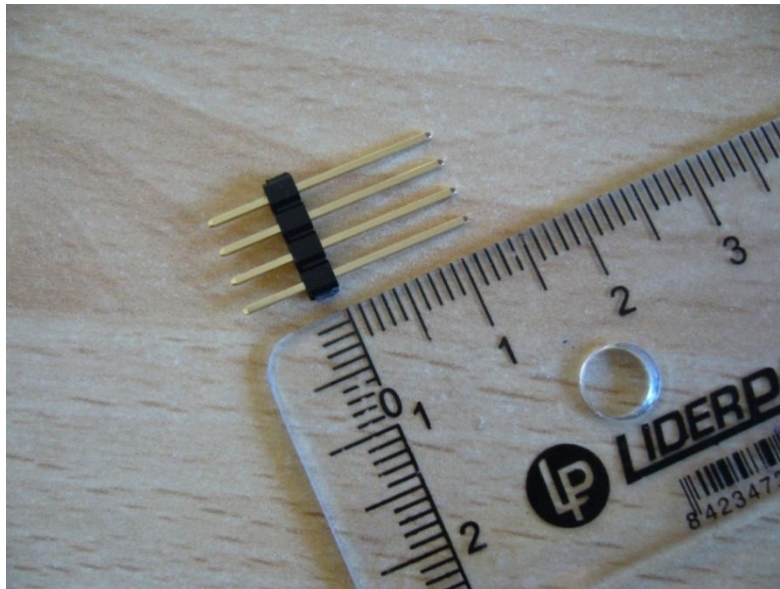

(3) After changing the pin strips should be about 12mm long.

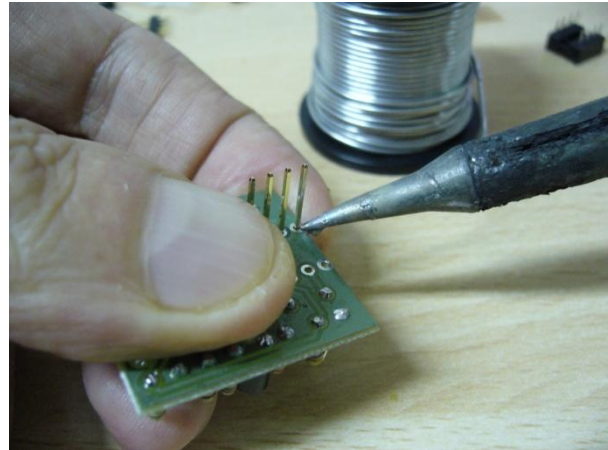
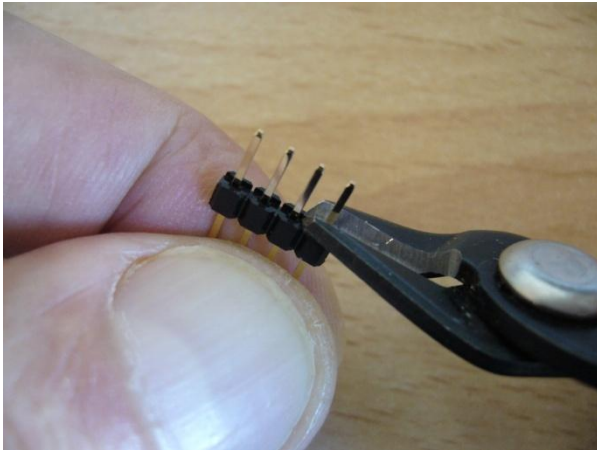

(4) Cut the short end of the pin flush and solder on the board. The plastic strip is on the component side.

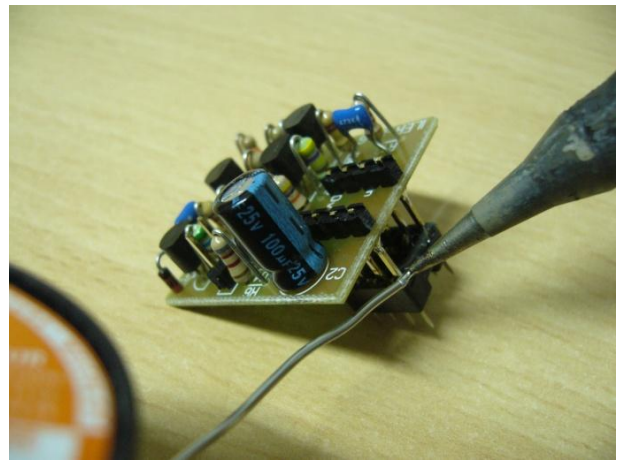
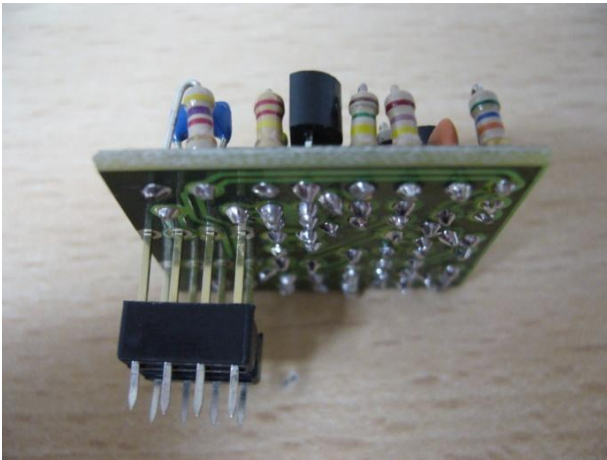

- (5) Insert the pins firmly in the IC socket. This socket is plugged into the socket IC4 ILER Board and also gives you a little more height to the entire set.
Ensure that the entire block is symmetrical, parallel to the base board etc.
With a fine tip soldering iron each female terminal socket can be carefully soldered (not essential)

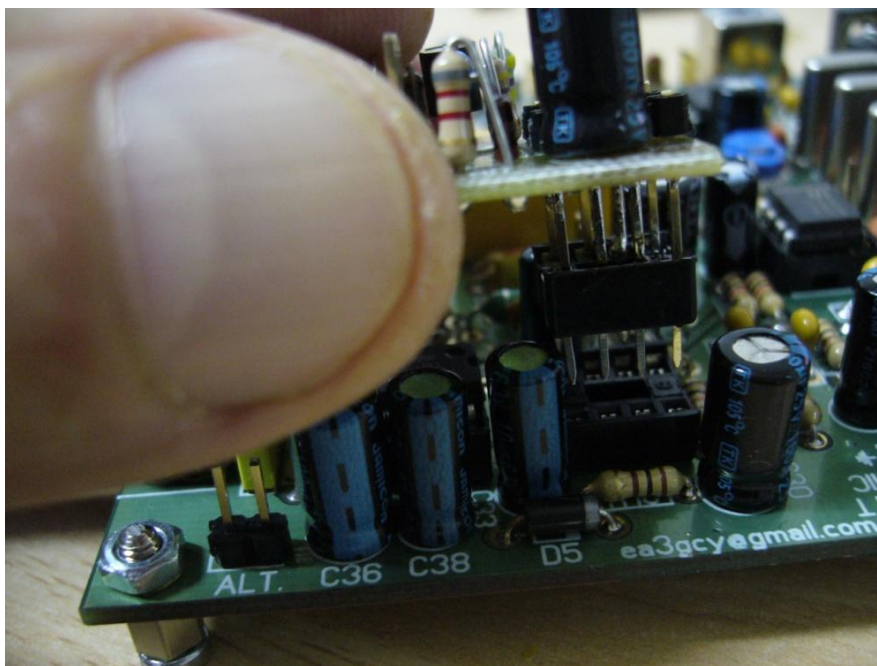

- (6) Plug in the whole board into IC4 socket

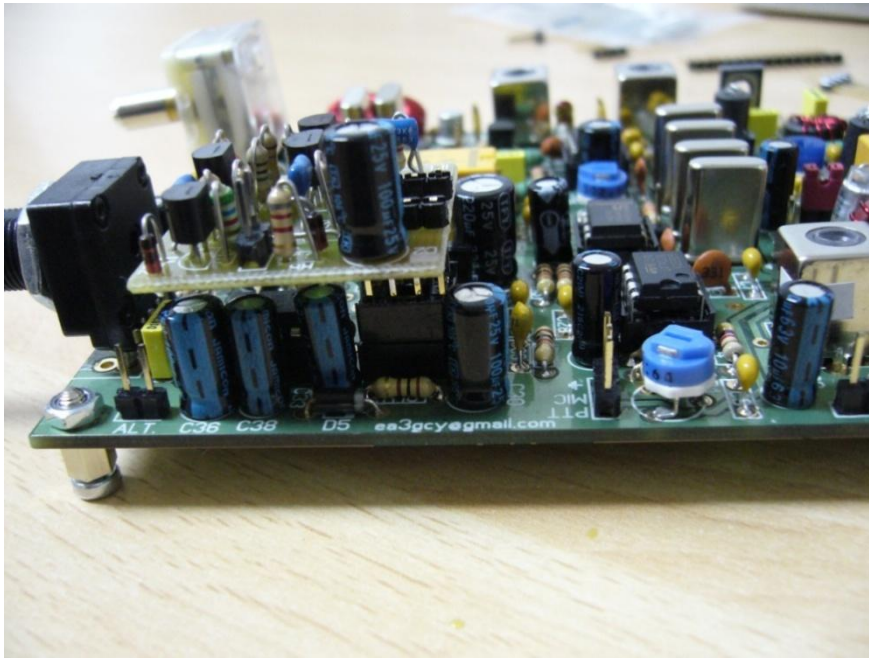

(7) The entire assembly must be rigid and parallel to the ILER board. Make sure there is enough clearance between the AGC and ILER components. When you are sure everything is working properly and do not want to make any changes, you can apply one or two drops of adhesive to stick the sockets together just to make sure. (be careful that the adhesive does not penetrate the contacts of the sockets because it can cause failure of contacts).



(8) observe here that R17 and C31 of ILER board have one end cut. (this is easier than having to take out board and completely remove them)
ENJOY!