

INSTRUCTION MANUAL

G-400 / G-400RC

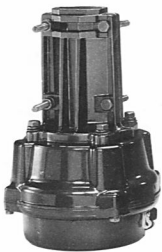

YAESU MUSEN CO., LTD.
C.P.O. BOX 1500
TOKYO, JAPAN

Provided by
<http://www.yaesu-museum.com>

YAESU G-400 & G-400RC LIGHT-DUTY ANTENNA ROTATOR & CONTROLLERS

The Yaesu G-400 and G-400RC are designed to support and rotate small-size amateur and medium- to large-size television antenna arrays under remote control from the station operating position. The factory-lubricated rotator unit is housed in weatherproof melamine resin coated die-cast aluminum, to provide maintenance-free operation under all climatic conditions. A mast alignment gauge on the rotator housing simplifies accurate mechanical alignment during installation.

The G-400 controller unit is a handsomely-styled, metered desktop unit which indicates antenna bearing azimuth in both compass direction and degrees, while the deluxe G-400RC controller provides 360° indication of actual antenna bearing azimuth on a circular dial indicator. Please read this manual carefully before installing the G-400.

SPECIFICATIONS

Voltage requirement: 110-120 or 220-240 VAC	Maximum dead vertical weight: 200 kg (440 lbs)
Power consumption: 40 VA	Control cable: G-400 - 6 conductors, or G-400RC - 5 conductors #20 AWG or larger
Motor voltage: 24 V, split phase	Mast diameter: 38 - 63mm (1-½ to 2-½ inches)
360° rotation time (approx.): 50 seconds @ 60 Hz	Weight: Rotator: 4.5 kg (9.9 lbs) Controllers: G-400 - 2.5 kg (5.5 lbs) G-400RC - 3.2 kg (7 lbs)
Rotation torque: 600 kg-cm (43.4 ft-lbs)	
Stationary braking torque: 2,000 kg-cm (145 ft-lbs)	

UNPACKING & INSPECTION

When unpacking the rotator confirm the presence of the following items:

Rotator Unit	1
Controller Unit	1
Mast Clamp	1*
Hex Bolts -	
M8 x 16	4
M8 x 25	4
M8 x 70	4
Split washer	12
Flat washer	4
M8 Nuts	4
Spare Fuse	
(117V:1A, 220V:0.5A)	1

If any of these items are missing or appear to be damaged, save the carton and packing material and notify the shipping company (or dealer, if purchased directly at his shop).

Before proceeding with installation, confirm that the AC voltage label on the rear of the Controller matches your local line voltage: either "117V" for 110 to 120 VAC, or "220" for 220 to 240 VAC. If the labelled voltage range does not match, return the controller to the dealer from whom you purchased it (different power transformers are installed for the different voltage ranges).

Note that cable is not included with the rotator, as the length must be determined case-by-case. Contact your Yaesu dealer to obtain the length of cable your installation requires. For runs of over 100 feet, use #18 AWG instead of #20 AWG.

* if your installation requires two mast clamps you can purchase the second clamp (Yaesu model GC-038 or GC-048) from your Yaesu dealer.

CONTROL CABLE PREPARATION & CONNECTION

Before installing the antenna and rotator, make all connections and test rotator operation thoroughly on the ground.

Your control cable should have six conductors (for G-400) or five conductors (for G-400RC) of at least #20 AWG gauge (if less than 100 feet long).

- (1) Remove the terminal box cover from the rotator, and slide the cover over one end of the cable.
- (2) Using special care to avoid nicking the insulation of the individual wires, strip back about 50mm of the outer jacket of the cable from each end, and then strip 15mm of insulation from each wire.

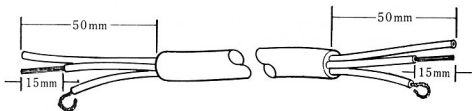

- (3) Twist the strands of each wire, and form each into a hook large enough to encircle the terminal screws on the rotator and controller. Then lightly tin each hook with solder (both ends of the cable should be prepared in the same way).
- (4) Connect each wire to a terminal, numbers 1 - 6 (or 2 - 6 for the G-400RC), on the rotator (the other terminals are not used). Note the color of the wire at each terminal.
- (5) Referring to your notes of the wire color at each terminal in the rotator terminal box, connect the wires to the terminals on the controller so that the wire from each terminal on the rotator plug connects to the terminal with the same number on the controller, i.e., 1 to 1 (G-400 only), 2 to 2, 3 to 3, etc.

- (6) On the controller, make sure that the POWER switch is in the OFF position, and connect the line cord to the AC power outlet.
- (7) Turn on the POWER switch. The pilot lamp should light, and on the G-400RC, the indicator move to 5° and stop.

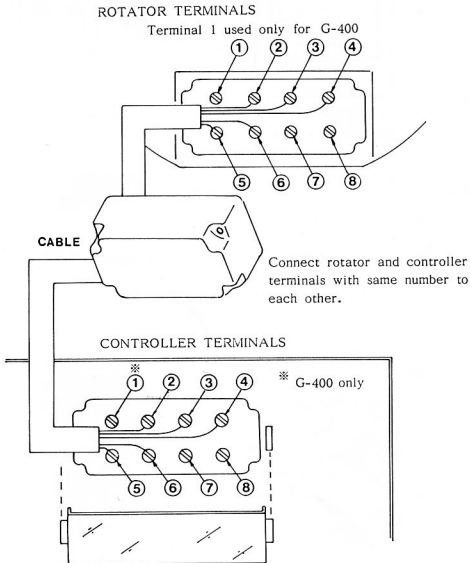

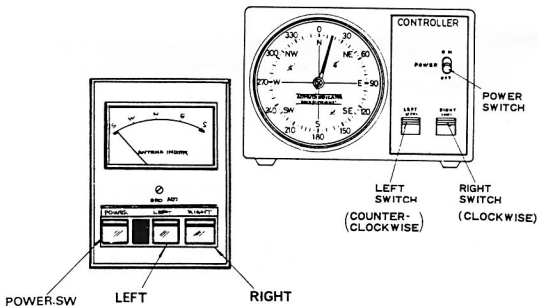

- (8) Press the RIGHT switch, and confirm that the rotator and direction indicator (in the G-400RC) turn clockwise together. In the G-400, the meter needle should move to the right. Release the RIGHT switch and confirm that the rotator slowly stops.
- (9) Repeat step 8, pressing the LEFT switch instead of the RIGHT switch. The rotator and direction indicator should turn counterclockwise (or the G-400 meter needle move to the left).
- (10) If operation does not occur as described above, check for a wiring error in the cable connections. When everything checks out in the above steps, slide the terminal cover over the rotator terminal box, and screw it tightly into place. Then remove the cable clamp from the rotator, clip it over the cable, and screw it back onto the rotator, leaving a little slack between the clamp and the terminal cover.

Notes on Controller Operation:

If both LEFT and RIGHT switches are pressed at the same time the rotator turns to the right (clockwise).

Release the LEFT or RIGHT switch when the meter indicates in the STOP zones (on the G-400), or when the indicator stops near north (on the G-400RC). Holding the switch down may otherwise damage the rotator.

Remember to turn the controller off when the rotator is not in use.

OPTIONAL PARTS



GS-050 50mm
THRUST BEARING



GS-065 65mm
THRUST BEARING



GC-038
MAST CLAMP

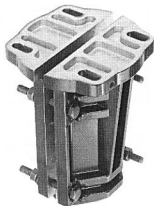

GC-048
MAST CLAMP

G-400 DIRECTION INDICATOR CALIBRATION

Press the LEFT switch and allow the rotator to turn fully counter-clockwise until rotation stops. The meter should now point precisely to 180° (South) at the left side of the meter scale. If not, adjust the zero adjust screw beneath the meter face so that it does.

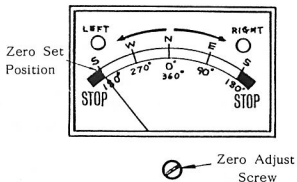

Press the RIGHT switch and allow the rotator to turn fully clockwise. The meter should now point to the 180° position at the right side of the meter scale. If not, adjust the calibration potentiometer on the rear panel so that it does.

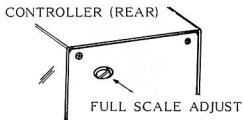
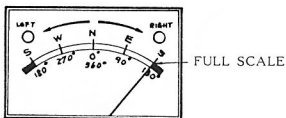

G-400RC DIRECTION INDICATOR CALIBRATION

Press the LEFT switch and allow the rotator and indicator to turn fully counterclockwise until rotation stops. The indicator should now point to 0° (North). If not, loosen the screw in the center of the indicator needle and reset the needle.

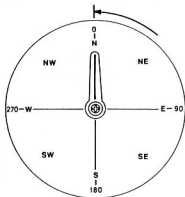

Press the RIGHT switch and allow the rotator and indicator to turn fully clockwise. The indicator should point to 5° (East of North). If not, adjust the calibration potentiometer on the rear panel.

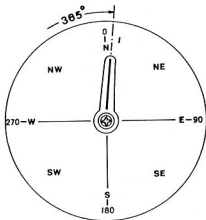

FULL SCALE
ADJUST POT TERMINAL

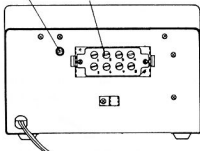

ROTATOR INSTALLATION

The rotator unit of the G-400 and G-400RC is designed to accommodate small-size antenna arrays. The maximum safe load depends on the physical size of the antenna, method and quality of mechanical installation, and maximum wind velocity at the installation site.

The following diagrams show several recommended installations. Notice that mounting the rotator inside of a tower provides the greatest support capacity, and is preferable for larger antennas or in high-wind areas. Use our GS-050 or GS-065 Tower Mount Bearing at the top of the tower (and make sure that the Bearing is aligned precisely with the center of the rotator, so the mast is exactly vertical).

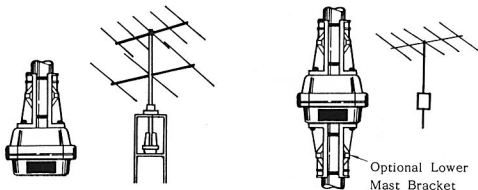

If the rotator is mounted alone on the mast above the tower it should be as close to the antenna as possible, to minimize the stress on the rotator caused by wind pressure against the antenna. This bending force on the rotator limits the supporting capacity of this type of installation to smaller antennas mounted close to the rotator. This method is not recommended in high-wind areas.

Make certain that the antenna attaches to the mast at the center of gravity of the antenna. That is, the antenna should be balanced, provid-

ing only downward force on the mast (when there is no wind). The G-400 can support up to 200 kg (440 lbs).

Be sure to leave enough slack in the coaxial cable feedline around the rotator so that it can rotate 360° without straining the feedline.

Mast Bracket Assembly & Antenna Positioning

- (1) Loosely fasten the mast bracket halves (1) to the rotator housing using four short bolts, split washers and flat washers (2).
- (2) Insert the mast into the bracket, and finger-tighten the four longer bolts (3) with split washers, flat washers and nuts (4).

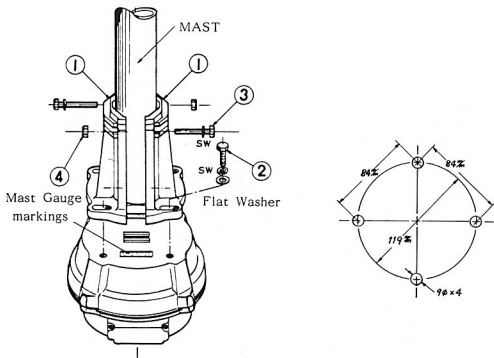

(3a) For G-400 only:

Set the controller so that it indicates precisely 180° (South) at the left edge of the indicator. Then, using an accurate map and known landmarks, position the antenna (without using the control-

ler) so that it points to true South. Alternatively, consult a Geodetic Survey map for your area to determine the Magnetic Deviation at your location, and then use a compass to position the antenna so that it points to true South (Magnetic North + Magnetic Deviation + 180°). Be careful not to disturb the antenna direction when tightening the mast bracket in step 4.

(3b) For G-400RC only:

Set the controller so that it indicates precisely 0° (North). Then, using an accurate map and known landmarks, position the antenna (without using the controller) so that it points to true North. Alternatively, consult a Geodetic Survey map for your area to determine the Magnetic Deviation at your location, and then use a compass to position the antenna so that it points to true North (Magnetic North + Magnetic Deviation). Be careful not to disturb the antenna direction when tightening the mast bracket in the next step.

- (4) Referring to the mast gauge markings on the rotator housing, tap the mast bracket halves to center the mast while alternately tightening the short bolts (2) and nuts (4) on the long bolts alternately.
- (5) Confirm the calibration of the controller indicator by rotating the antenna precisely 360° so that the antenna itself is pointing in the same direction as before. If the indicator does not show exactly 180° (G-400) or 0° (G-400RC) again, adjust the FULL SCALE potentiometer on the rear of the controller slightly, and repeat this step.

CAUTION: The rotator unit is designed for vertical mounting only. Water and contaminants will damage the motor unit if it is mounted horizontally or upside-down.

The rotator motor is rated for five-minutes intermittent duty. However, it can safely run continuously for as long as ten minutes providing that it be brought to rest for at least ten minutes afterwards.

G-400RC SCHEMATIC DIAGRAM

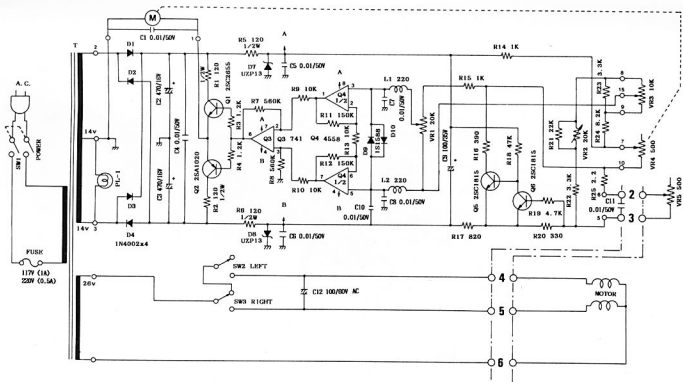

G-400 SCHEMATIC DIAGRAM

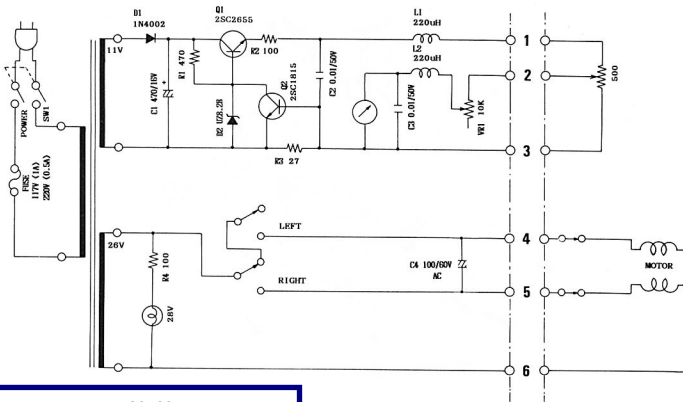

Provided by
<http://www.yaesu-museum.com>

Downloaded by
 Amateur Radio Directory

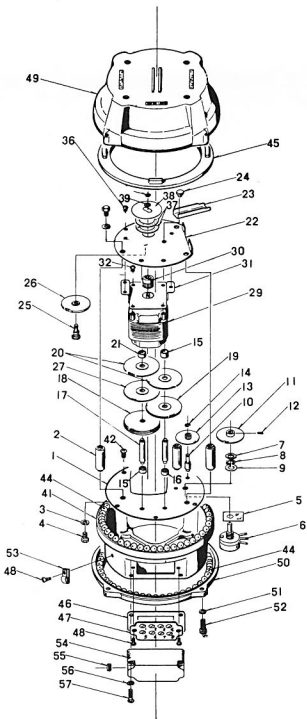

PARTS LIST (Rotator)

- | | |
|------------------------------------|--|
| (1) Gear Mounting Plate Ass'y | (41) Lower Housing |
| (2) Gear Mount Support (x3) | (42) 5mm Gear Plate Screw (x6) |
| (3) 6mm dia Washer (x3) | (44) Ball Bearings |
| (4) Gear Mount Screw (x3) | (45) Internal Ring Gear |
| (5) Insulating Sheet | (46) Rubber Seal: Terminal Box |
| (6) Potentiometer | (47) Terminal Ass'y |
| (7) 9mm Pot. Shaft Nut | (48) Terminal Ass'y/Cable Clamp
Screw |
| (8) 9mm Pot. Shaft Lock Washer | (49) Upper Housing |
| (9) 9mm Pot. Shaft Flat Washer | (50) Housing Ring |
| (10) Pot. Gear Shaft #1 | (51) 6mm Housing Washer |
| (11) Pot. Divider Gear | (52) Housing Screw |
| (12) Pot. Div. Gear Setscrew | (53) Cable Clamp |
| (13) Plastic Pot. Gear | (54) Terminal Cover |
| (14) 2.5mm dia. E-Ring | (55) Rubber Grommet |
| (15),(16),(21) Stud Support Sleeve | (56) 4mm Washer |
| (17) Gear Shaft (x2) | (57) Terminal Cover Screw |
| (18) Main Gear | |
| (19),(20) Pinion Gear Ass'y | |
| (22) Gear/Motor Mount Plate | |
| (23) Revolution Stopper | |
| (24) Stopper Mounting Pin | |
| (25) Pot. Gear Shaft #2 | |
| (26) Plastic Pot. Gear | |
| (29) Motor Ass'y | |
| (30) Motor Pinion Gear | |
| (31) Motor Mount Plate | |
| (32) 3mm dia Motor Mount Screw | |
| (36) 4mm Motor Mount Screw
(x3) | |
| (37) Brake Disk Pad | |
| (38) Brake Disk Plate | |
| (39) 3.5mm dia Flat Washer | |



Provided by
<http://www.yaesu-museum.com>

Downloaded by
Amateur Radio Directory

ご 注 意 CAUTION

- ★マストクランプ締付けネジ(M8 X 70) は締めすぎない様にして下さい。
スプリングワッシャーが平らになってから 4本とも平均に半回転ほど締めれば充分です。 それ以上締付けますと、マストクランプにヒビが入る恐れがあります。
- ★ Please don't overtighten the clamp ③bolts(M8 x 70) .
After the spring washer comes flat, tighten the bolt no more than another 1/2 turn. That is enough to support the mast.

締 付 順 序 CLAMP ASSEMBLY

1. マストクランプ①を本体に②(M8 X 25) のボルトで仮どめします。

Loosely mount the Mast clamp① to the rotor unit with the bolt②(M8 x 25).

2. マストを挿入しアンテナの方向を確認してから③(M8 X 70) のボルトと④のナットで締めます。

After inserting the mast between clamps, set the antenna direction to the desired direction and tighten the bolt ③ (M8 x 70) with nut④.

3. マストゲージを利用しローターの中心が合ひようにして②のボルト(M8 X 25) を締めます。

Referring to the Mast Gauge on top of the rotor unit, place the mast center so as to coincide with the center of the rotor unit and tighten the four ②bolts.

