

TECHNICAL MANUAL  
RADIO SET PRC1099  
TW-PRC1099-TM1



## WARRANTY

Trans World Communications, Inc. (TWC) warrants that new TWC equipment has been manufactured free of defects in design, material and workmanship. If the equipment does not give satisfactory service due to defects covered by this warranty, TWC will, at its option, replace or repair the equipment free of charge.

The warranty is for a period of 90 days from the date of installation. In the event that the equipment is not installed within 90 days of factory shipment, satisfactory evidence of the installation date must be submitted.

### LIMITATIONS:

This warranty does not cover physical damage caused by impact, liquids or gases. Defects caused by lightning, static discharge, voltage transients, or application of incorrect supply voltages are specifically excluded from this warranty.

### RETURN OF EQUIPMENT - USA:

The equipment shall be returned freight prepaid to the Service Department, Trans World Communications, Inc., 304 Enterprise Street, Escondido, California 92025. The equipment should be packed securely, as TWC will not be responsible for damage incurred in transit. Please include a letter containing the following information:

1. Model, serial number, and date of installation.
2. Name of dealer or supplier of equipment.
3. Detailed explanation of problem.
4. Return shipping instructions.

TWC will return the equipment prepaid by United Parcel Service, Parcel Post or truck. If alternate shipping is specified, freight charges will be made collect.

### RETURN OF EQUIPMENT - FOREIGN:

Write for specific instructions. Do not return equipment without authorization. It is usually not possible to clear equipment through U.S. Customs without the correct documentation. If equipment is returned without authorization, the sender is responsible for all taxes, customs duties and clearance charges.

### LIMITED PARTS WARRANTY:

This warranty shall cover all parts in the equipment for a period of 12 months from the date of installation, subject to the previous conditions and limitations. The parts will be replaced free of cost. The labor charges will be made at the current TWC hourly service rate.

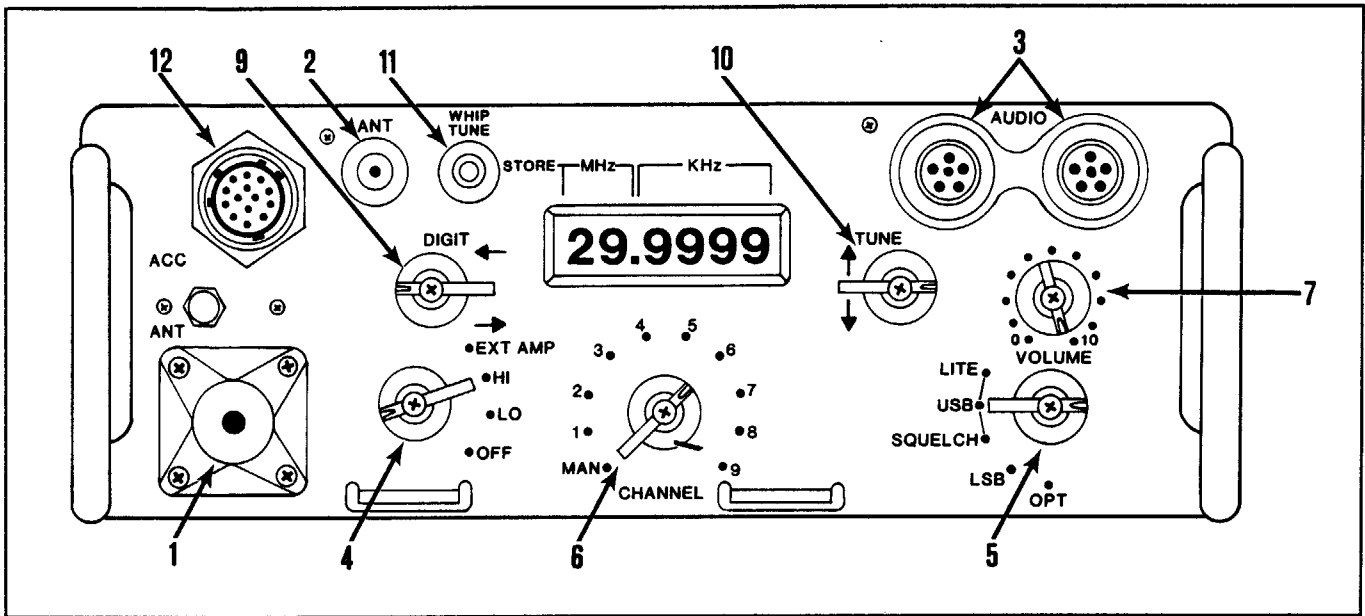
### PARTS REPLACEMENT:

If it is not practical, or the purchaser does not want to return the equipment to the factory, this warranty is limited to the supply of replacement parts for a period of 12 months from the date of equipment installation. The following instructions for the supply of replacement parts should be followed:

1. Return defective parts prepaid to: Parts Replacement, Trans World Communications, Inc., 304 Enterprise Street, Escondido, California 92025.
2. Include a letter with the following information:
  - a) Part number(s).
  - b) Serial number and model of equipment.
  - c) Date of installation.

Parts returned without this information will not be replaced. In the event of a dispute over the age of the replacement part, components date coded over 24 months prior will be considered out of warranty.

## CONDENSED OPERATING INSTRUCTIONS FOR RADIO SET PRC1099



### 1. TO OPERATE SET

- Install the whip antenna in the antenna socket (1) OR attach 50-ohm antenna feedline to BNC antenna connector (2).
- Attach the handset to either audio connector (3). NOTE: Remote handset attaches to the right audio connector only.
- Turn the power switch (4) to the power level for the type of operation desired. (HI gives maximum range.)
- Turn the function switch (5) to USB.
- Select the desired channel number (6). NOTE: Front-panel CHANNEL switch must be in "MAN" to use remote channel switch.
- Turn the VOLUME control (7) to 5.
- Press the handset push-to-talk switch and talk into handset. Release to listen.
- Adjust volume control (7) for desired sound level.

### 2. TO RETUNE ANTENNA

- Depress the WHIP TUNE (11) button (Do not hold down). The antenna-tuning information is updated and stored in memory.

### 3. TO CHANGE CHANNEL FREQUENCIES

- Set CHANNEL switch (6) to "MAN".
- Turn the DIGIT switch (9) UP or DOWN to select the desired digit. The selected digit will flash.
- Turn the TUNE switch (10) UP or DOWN to select the correct number.
- To change the frequencies in channels 1-8, set the control (6) to the desired channel number, press and hold the store button and repeat steps 3A-3C.

### 4. TRANSADAPT OPERATION

- To install Selcall Code, hold the DIGIT switch (9) down until a three-digit number is displayed, enter the code using the TUNE switch (10).
- To enter TRANSADAPT Mode 1, hold DIGIT switch (9) down and press WHIP TUNE (11).
- To enter TRANSADAPT Mode 2, select channel 9 and press WHIP TUNE (11).
- To enter TRANSADAPT Mode 3, press WHIP TUNE (11). NOTE: must already be linked in TRANSADAPT Mode 2 to utilize Mode 3.

### 5. MEMORY DUMP FEATURE

- Hold the WHIP TUNE (11) button in, hold DIGIT Switch (9) up, switch radio on.

### NOTES

- LOW BATTERY - Display flashes.
- ACCESSORY CONNECTOR (12) - Cap must be connected whenever accessory connector is not in use.
- RF OUTPUT NORMAL - Transmit sidetone is heard.

**OPERATOR'S & ORGANIZATIONAL MAINTENANCE MANUAL**  
**RADIO SET PRC1099**

---

|  | Paragraph  | Page       |
|--|------------|------------|
| CHAPTER 1. INTRODUCTION                        |            |            |
| Section I. General                             | 1-1        | 1-1        |
| Section II. Description and Data               | 1-2 - 1-6  | 1-1 - 1-4  |
| CHAPTER 2. INSTALLATION                        | 2-1 - 2-6  | 2-1 - 2-4  |
| 3. OPERATING INSTRUCTIONS                      | 3-1 - 3-16 | 3-1 - 3-5  |
| 4. OPERATOR'S MAINTENANCE INSTRUCTIONS         | 4-1 - 4-8  | 4-1 - 4-2  |
| 5. FIELD MAINTENANCE INSTRUCTIONS              | 5-1 - 5-9  | 5-1 - 5-4  |
| 6. HF COMMUNICATIONS & SINGLE SIDEBAND         | 6-1 - 6-3  | 6-1 - 6-2  |
| 7. ANTENNA SYSTEMS                             | 7-1        | 7-1 - 7-4  |
| APPENDIX A. ORGANIZATIONAL REPAIR PARTS        | A-1 - A-3  | A-1 - A-2  |
| APPENDIX B. OPTIONAL ACCESSORY EQUIPMENT       | B-1 - B-2  | B-1 - B-12 |
| APPENDIX C. BATTERY TYPES AND ACCESSORY CABLES |            | C-1-C2     |
| INDEX  |            | I-1 - I-2  |



**FIGURE 1-1.**

**Radio Set PRC1099 in Manpack Operation with Antenna AT-271A and Support AB-591 installed.**

# CHAPTER 1 INTRODUCTION

## Section I. GENERAL

### 1-1. Scope

a. This manual describes Radio Set PRC1099 and covers its installation, operation, and operator's organizational maintenance.

b. Items comprising an operable equipment (Para. 1-6).

c. Information on technical service and the maintenance of the PRC1099 is contained in the technical manual TW-PRC1099-MS1.

## Section II. DESCRIPTION & DATA

### 1-2 Purpose and Use (Figure 1-1)

a. Radio Set PRC1099 is a high-frequency, manpack-portable, single-sideband (SSB) transceiver used to provide long-range, two-way, voice, CW, and data communication.

b. The Radio Set PRC1099 may also be used as part of the Transworld RA100, RA400/5 or RA1000/5 high power fixed, portable and mobile stations.

c. The Radio Set PRC1099 can communicate with most HF SSB radios operating within the 1.6- to 30-MHz range.

d. The PRC1099 can be used in conjunction with the other equipment (1) through (8) below.

(1) Long-wire antennas can be used in place of the whip antennas, using the internal tuner to extend the communication range.

(2) Coaxial-fed 50-ohm antennas such as resonant dipoles, broadband antennas and directional antennas can be used in place of the whip antenna for extended range, or where directional transmission/reception is desired.

(3) The antenna tuner RAT100 can be used with the PRC1099 in mobile installations and other applications where the antenna must be located away from the transceiver.

(4) The PRC1099 can be operated from the ac power supply PRC-PS in place of the internal battery.

(5) The PRC1099 can be used with high power amplifiers RA100 (100 W), RA400/5 (400 W), or RA1000/5 (1000 W) and can provide automatic control of these amplifiers.

(6) Remote control of the PRC1099 can be provided by radio set control groups GRA-39.

(7) Loudspeaker, electromagnetic LS-549/PRC can be used with the PRC1099 to monitor radio reception.

(8) The PRC1099 can be used with the morse key KY562 for telegraphy.

(9) The PRC1099 can be used with secure voice equipment designed for HF SSB operation.

(10) The PRC1099 can be used for digital data (burst or RTTY) transmission and reception.

### 1-3. Technical Characteristics

Frequency Range: 1.6-30 MHz.

Number of Channels: 284,000.

Memory Channels: 10.

Channel Spacing: 100 Hz.

#### Types of Transmission and Reception:

Transmission - Voice - (300-2700 Hz) SSB, USB/LSB.  
CW - semi break-in.

Reception - Data - with external modem.  
Voice - (no squelch, noise immune squelch).  
CW  
Data - with external modem.

Security Equipment: Equipment must be designed for HF/SSB.

#### Transmission and Reception Power Requirements:

Transmission - 12.0 - 15 Vdc.  
High Power - Avg. voice 1.5 A.  
Low Power - Avg. voice 1.0 A.  
Reception - 12.0 - 15 Vdc.  
Squelched 100 mA typical.  
Unsquelched 130 mA typical.

Type of Modulation: Single Sideband - USB/LSB.

Transmitter Power Output: Selectable - 5 W, 20 W.

Type of Squelch: Noise immune.

#### Types of Antennas:

Whip Antenna - Antenna AT-271A, 10-ft long, multisection whip with AB591 Flexible Support.  
Long Wire - 25-ft, 50-ft, 100-ft or random length long wire.  
50- $\Omega$  Antenna - 50- $\Omega$  coaxial fed antennas with VSWR 3:1 or less.

#### Power Source:

Lithium battery, sealed lead-calcium battery (rechargeable), or PRC-PS ac power supply.

#### Battery Life:

High power 50 hours (9:1 receive-transmit ratio) with BA6598/U.

### 1-4. Items Used with PRC1099 (Figure 1-2)

The following components are normally used with the PRC1099 in the manpack configuration. Dimensions and

weights of components are provided in paragraph 2-1. A battery is required to operate the PRC1099. Suitable battery types and their characteristics are shown in Table C-1 of Appendix C.

| <u>Trans World Part No.</u> | <u>Item</u>                              |
|-----------------------------|--|
| PRC1099                     | Radio Set PRC1099 (includes battery box) |
|                             | Antenna AT-271A/PRC                      |
|                             | Bag Cotton Duck CW-503                   |
|                             | Handset H-250/U                          |
|                             | Harness Electrical Equipment ST-138      |
|                             | Support, Antenna AB-591                  |

### 1-5. General Description (Figure 1-2)

Radio Set PRC1099 consists of the transceiver and battery box described in (a). The normal accessory components are described in (b).

#### a. TRANSCEIVER, RADIO PRC1099.

The PRC1099 consists of the transceiver, the transceiver case, and the Battery Box CY-2562.

(1) The transceiver is held in the case by four captive screws. The battery box is attached to the case by two clamps. The complete PRC1099 is watertight when assembled. All controls are on the front panel. The battery connector projects from the bottom of the case and plugs into the battery which is contained in the battery box.

(2) The CY-2562 battery box is a lightweight metal case that protects and houses the battery. The battery sits on a foam pad that is attached to the bottom of the case which prevents battery movement.

(3) A pressure relief valve is installed in the battery case to vent the hydrogen gas (a by-product of the magnesium battery discharge action), thus preventing the gas from accumulating in the transceiver case and exploding. It is important that battery cases have the pressure relief valve when using magnesium batteries.

#### b. ACCESSORY COMPONENTS (Figure 1-2)

##### (1) Antenna AT-271A/PRC

The AT-271A is composed of six sections; each section fits into the end of a wider section. A braided plastic cord, under spring tension, is threaded through the sections to keep them together in the operating condition. When the sections are folded, the cable keeps them together as a

group and prevents the loss of individual sections. Spring tension is proved by a spiral spring in the base section.

##### (2) Support, Antenna AB-591

The AB-591, which has semi-flexible, tubular construction, is used as the main support for the AT-271A. The pin at the base of the support activates the internal antenna tuner.

##### (3) Harness, Electrical Equipment ST-138.

The ST-138 is used to secure the PRC1099 so that it can be carried on the operator's back.

##### (4) Bag, Cloth CW-503

The CW-503 is sectionalized into several pockets which are used to store the antennas, the antenna support, and the handset (Figure 1-3).

##### (5) Handset H-250/U

The H-250/U contains a dynamic microphone and receiver for transmitting and receiving signals (Figure 1-4). A push-to-talk switch is mounted in the handle. The connecting cord is retractile and terminates in a five pin connector.

The PRC1099 may also be used with Handset H-189/GR.

### 1-6. Battery (Figure 2-1)

a. Battery, Lithium BA5598/U or BA6598 may be used to operate the PRC1099. The battery is provided with a female connector to mate with the male connector on the PRC1099. The battery case will hold a spare BA5598/U or BA6598 battery.

b. Battery, Sealed Lead-calcium BB-LA6 12V, 6AH may also be used with the PRC1099. This battery can be recharged after use.

c. Battery, Dry BA4386/U may also be used with the PRC1099. Because of the limited current capability, restrict the power output to 5 W when using this battery.

#### **CAUTION**

*Never recharge the lithium or dry batteries. This could cause an explosion resulting in severe damage to the transceiver and danger to personnel.*

d. The PRC1099 may be used with other types of batteries, such as NiCad, with an output voltage of 12-15 Vdc.





## CHAPTER 2 INSTALLATION

### 2-1. Unpacking

a. **Packaging Data.** The PRC1099 is packed in a heavy duty, corrugated cardboard carton. The accessories are packed in a separate carton. The cartons and packing

materials should be retained in case the equipment is reshipped.

b. **Component Dimensions** (See table below).

| Component                            | Overall Dimensions (in.) |       |       | Volume (cu in.) | Weight (lb) |
|--------------------------------------|--------------------------|-------|-------|-----------------|-------------|
|                                      | Height                   | Width | Depth |                 |             |
| Transceiver, Radio PRC1099           | 4.00                     | 11.00 | 9.50  | 418             | 9.72        |
| Battery Box CY-2562                  | 4.00                     | 11.00 | 3.00  | 132             | 0.82        |
| Support, Antenna AB-591              | 9.00                     | 0.75  | 0.75  | 50              | 0.75        |
| Antenna AT-271A                      | 17.00                    | 0.75  | 0.75  | 9               | 0.75        |
| Harness, Electrical Equipment ST-138 | 19.00                    | 6.00  | 5.00  | 520             | 3.00        |
| Bag, Cotton Duck CW-503              | 19.00                    | 4.00  | 5.00  | 456             | 0.75        |
| Handset H-250/U                      | 7.75                     | 2.00  | 3.50  | 54              | 0.55        |

### 2-2. Checking Unpacked Equipment

Inspect the equipment for possible damage during shipment. Check all accessories against the packing list.

f. Install the battery case and tighten the clamps.

#### **CAUTION**

*Remove the battery when the transceiver is not in use for more than one day.*

### 2-3. Siting

The PRC1099 operates in the high frequency spectrum where the signals are reflected by the ionosphere and line-of-sight is not required. Since the signal may be absorbed by tall buildings or vegetation, the operating site should be clear of obstacles directly in the line of communication. A good ground or counterpoise will extend the operating range, and it is preferable to site the transceiver where a ground can be connected to the ground terminal. If possible, avoid locations near sources of electrical interference, such as power or telephone lines, electric motors or gasoline engines.

### 2-5. Assembly and Installation for Man-Pack Operation (Figure 2-2)

### 2-4. Installation of Battery (Figure 2-1)

a. Stand the PRC1099 on a level surface with the front panel facing down.

a. Attach the transceiver to the harness as instructed in (1) through (4).

b. Release the two clamps by pushing down.

(1) Place the harness flat on a level surface with the metal braces facing up.

c. Remove the battery box.

(2) Place the transceiver on the harness with the front panel to the top and the battery case resting on the metal braces.

d. Check the battery connector; if it is damaged, the transceiver must be repaired. Check that the pressure test screw and relief valve are tight.

(3) Fasten the transceiver to the harness with the two retaining straps; feed the metal-tipped strap from below, through the center slot on the buckle, and then down through the end slot on the buckle.

e. Position the battery so that the connectors are aligned and then mate the connectors.

(4) Clip the Bag CW-503 to the harness.

b. Mount the transceiver and harness on the operator as follows:

(1) Install the desired antenna (Para. 2-6).

(2) Connect the handset to one of the audio connectors on the front panel of the transceiver.







## CHAPTER 3 OPERATING INSTRUCTIONS

### CAUTION

Battery power should be between 12.0 V and 15 Vdc, with positive (+) applied to the B terminal on the battery connector (at the back of the transceiver) and negative (-) applied to the A terminal. Do not change the battery polarity or the transceiver will be seriously damaged.

### 3-1. Transceiver, Radio PRC1099, Controls, Indicators and Connectors (Figure 3-1)

| Control, Indicator, or Connector               | SW Position                                      | Function/Action   |
|--|--|---|
| POWER Switch                                   | OFF  | Turns transceiver off.  |
|  | LO   | Turns transceiver on - Low Power, 5W.   |
|  | HI   | Turns transceiver on - High Power, 20W.   |
|  | EXT AMP  | Turns on the external amplifier when connected.   |
| FUNCTION Switch                                | USB  | Transceiver operates on the normal (upper) sideband, no squelch.  |
|  | SQUELCH  | Receiver squelched — no background noise. Opens when signal received. USB operation.  |
|  | LSB  | Transceiver operates on opposite (lower) sideband.  |
|  | LITE   | Spring loaded position backlights frequency display. USB operation.   |
|  | OPT  | Normally data mode.<br>AME option — Transceiver operates in compatible AM (AME) mode, no squelch.   |
| CHANNEL Switch                                 | MAN  | Selects the manual tune position. Front-panel channel switch must be in the MAN position to use optional remote handset channel switch.   |
|  | 1-9  | Selects pre-set channel frequencies.  |
| Remote CHANNEL Switch<br>(Remote handset only) | IC   | Selects the manual tune position. Remote channel switch must be in the IC position to use front-panel channel switch.   |
|  | 1-9  | Selects preset channel frequencies.   |
| DIGIT Selection                                | ←  | Spring Loaded - selects digit to be tuned; right to left.   |
|  | →  | Spring Loaded - selects digit to be tuned; left to right.   |
| TUNE Control                                   | ↑  | Spring Loaded - increments frequency higher in 100 Hz* steps.   |
|  | ↓  | Spring Loaded - increments frequency lower in 100 Hz* steps.  |
|  |  | * Larger tuning steps if selected by DIGIT switch.  |
| WHIP Tune                                      | DEPRESS  | Activates automatic antenna tuner to tune whip or long wire antennas.   |
| STORE<br>BITE                                  | (momentarily)                                    |   |
|  | DEPRESS (Hold)                                   | Permits resetting frequency on channels 1-9.  |
|  | DEPRESS (Hold)<br>(while turning transceiver on) | Activates BITE (Built-In-Test-Equipment) (Refer to 3-7).  |
| Liquid Crystal Display                         |  | Displays channel frequency.   |
| VOLUME Control                                 |  | Varies receiver and sidetone volume.  |
| Remote VOLUME Control                          |  | Varies receiver and sidetone volume to earphone. Lowest setting turns earphone off.   |
| AUDIO Connector (2)                            |  | Provides connection for handset or audio device.  |
| ANT Mount                                      |  | Provides connection for antenna AT-271A or Long Wire Adaptor.   |
| ANT Connector                                  |  | Provides connection for fixed base or 50Ω vehicular antenna, or external power amplifier.   |
| POWER Connector                                |  | Provides connection for external power supply when PRC1099 is used as part of vehicular radio set configurations. When the connector cover is removed, the PRC1099 is disconnected from the battery pack. Rechargeable batteries may be recharged through this connector. Provides control for external accessories such as power amplifiers. |



- (1) Press the push-to-talk switch on the handset.
- (2) Speak into the handset.

**NOTE**

The H-250/U Handset has a noise cancelling microphone. There will be almost no output when speaking more than 1/2 inch from the microphone element.

- g. To receive, release the push-to-talk switch on the handset.
- h. The background noise in the handset can be eliminated by turning the function switch to SQUELCH. This also reduces the receiver current drain.
- i. The PRC1099 has two transmitter power output levels - High and Low. Using low power will reduce battery drain.

**3-5. Antenna Tuning Procedure**

- a. The antenna tuning procedure is fully automatic and is activated by a momentary depression of the WHIP TUNE switch. (Do not hold switch down as this is a dual function switch and will change to STORE operation after 1 second). A tone will be present in the handset during tune cycle. A pulsed tone at the end of the tune cycle indicates that the tuner has not been able to match the antenna correctly.
- b. The tuning information is stored in memory and is automatically selected when the channel is changed.
- c. The automatic antenna tuner will only operate when the AB-591 support or the LWA Long Wire Adapter is installed.
- d. The antenna tuning varies considerably according to the positioning of the transceiver and the location. The tune information should be updated frequently. Always retune the antenna if the communications are unsatisfactory.

**3-6 Stopping Procedure (Figures 1-2 and 1-3)**

- a. To turn off the transceiver, set the Power Switch to OFF.
- b. If the AT-271A Whip Antenna was used, disable it as follows:
  - (1) Unscrew the AT-271A from the support AB-591.
  - (2) Beginning with the top section, pull out each section from the next section and fold it along the side of the next lower section.
  - (3) Unscrew the Support AB-591 from the antenna mount.
- c. Store the handset, both antennas, and the base in the Bag CW-503 and close the flaps.

**3-7 BITE Operation**

BITE (Built-In-Test-Equipment) is a series of automatic "built-in" tests to allow the operator to check vital components and functions of the PRC1099. These tests are briefly described below.

| TEST NUMBER | TEST                          | TEST DESCRIPTION   |
|-------------|-------------------------------|--|
| 1           | Battery                       | Tests battery condition                                      |
| 2           | Antenna                       | Checks if antenna is installed                               |
| 3           | LCD Display                   | Tests LCD Display  |
| 4           | Microprocessor                | Tests Microprocessor   |
| 5           | Receiver, USB                 | Tests receiver in USB  |
| 6           | Receiver, LSB                 | Tests receiver in LSB  |
| 7-12        | Transmitter/<br>Antenna Tuner | Tests transmitter and antenna tuner at different frequencies |

- a. Set power switch to OFF.
- b. Make sure the antenna and handset are installed (refer to section 2-6).
- c. Set the mode switch to USB and the VOLUME control to mid-position.
- d. While pressing the WHIP TUNE/STORE button, set the power switch to LO.
- e. Release WHIP TUNE/STORE button.
- f. The BITE tests will begin, displaying "TEST:xx" then "PASS:xx" (where "xx" represents the test number) at the conclusion of each test. Test 3 requires that the operator verify that the number "8" is displayed once in each digit position of the display and that a "decimal point" is displayed once between each digit. If any of the above are not displayed, the display may be malfunctioning, which indicates failure of this test. Tests 5 and 6 require that the operator listen in the handset for an audible tone. If the tone is not heard, the operator must fail the test. Failure of any of the other tests are indicated on the LCD display by "Err:xx" (where "xx" represents the test number). If a failure occurs with any test, the problem should be referred to qualified personnel.

**NOTE**

The following built-in tests are available during normal operation.

- g. BATTERY VOLTAGE - Low battery voltage is indicated by a flash display in the receive mode.
- h. POWER OUTPUT - The power output is detected by a special peak reading power detector. The sidetone in the handset is only switched on when the correct power output is reached. The monitoring circuit adjusts automatically for low power operation.

i. RECEIVER/EXCITER PERFORMANCE - The sidetone is generated by listening to the low level exciter output in the receiver and provides a complete operational check of these components. Any excessive distortion or low level on the sidetone indicates a defect in the exciter/receiver.

j. ANTENNA TUNING - If the antenna tuner cannot achieve a correct match, this is indicated by a pulsating tone in the handset.

### 3-8. Recognition and Identification of Jamming

Jamming is the intentional transmission of signals to prevent communications. Strong unidentified transmissions may be enemy jamming. Unusual noises on the channel may also be jamming or may be interference from a local noise source. It is also possible for a faulty receiver to cause internal interference to the received signal. Make the following checks:

a. Remove the antenna. If the noise does not disappear, there is a fault in the receiver.

b. Switch to several different channels. If the interference is present on all channels, it is probably caused by a local noise source. If the jammer is located at a considerable distance, the propagation conditions may mean that it is not possible to jam on all frequencies.

### 3-9. Anti-Jamming

When jamming is first noted, try the following procedures.

a. Operate at low power if satisfactory communications can be achieved. This makes it difficult for the jamming source to intercept the transmissions and determine the jamming frequency.

b. Change the channel frequency. The PRC1099 has the ability to change to new frequencies as quickly as the operator can turn the channel switch. Unless the jammer is using very advanced jamming equipment, it will take some time to find the operating frequency and start jamming. Many different procedures can be used to minimize jamming. Typical procedures are described.

(1) Scheduling - Specified channel frequencies are used in specific time slots. For example, channel 1 may be used from 00 minutes to 15 minutes past the hour, and so on, in a similar sequence.

(2) Change Frequency Upon Initiation of Jamming - Set up a schedule of frequency changes. When jamming commences, the operators will change to the next frequency listed in the schedule. This procedure is particularly effective when only two stations are communicating.

### 3-10. LSB - Lower Sideband Operation

When LSB is selected on the mode switch, the sidebands are inverted in the transmit and receive modes. Switching to LSB (at both transceivers) may be used to avoid inter-

ference. Always revert to USB after using LSB, as wanted calls cannot be received while operating in the LSB mode.

### 3-11. CW Operation

The PRC1099 will operate in the CW mode (telegraphy) when the key is installed in one of the audio connectors. The transceiver automatically switches to the CW mode and semi break-in keying is used. This means that the transmitter is held on when the key is depressed and will automatically return to receive when there is a short break in the transmission. A receiver sidetone is provided to monitor the keying.

### 3-12. System Application

The PRC1099 can communicate with other HF SSB stations in the 1.6-30 MHz frequency range. The single sideband mode cannot be received by AM receivers.

### 3-13. Channel Scanning Operation

PRC1099-SCAN is a retrofitable software option which allows sequential scanning of eight channels by the transceiver. When this option is fitted, the unit will scan channels one through eight at a rate of one channel every three seconds. The internal antenna tuner, if utilized, will automatically set itself to the memorized position for each channel during the scan cycle.

### 3-14. Scanning Operation

a. When the internal tuner is to be used, manually tune channels one through eight (1-8) with the actual antenna in place before beginning the scan. This sets up the tuner memory for each channel.

b. Set the channel select knob to channel nine (9). The set will then begin scanning the channels.

c. To manually stop the scan, select one of the channels one through eight (1-8) or MANUAL.

d. If the transmitter is activated, the scan will stop and the frequency of the current channel will be displayed. Sixty seconds after the end of the last transmission, the unit will begin scanning again automatically.

e. The scanning feature can be utilized with the PRC-SELCALL selective calling system. If a call is received during the scan cycle, the answerback will automatically stop the scan as the alarm is sounded.

### 3-15. Compatible AM (AME) Operation

This mode is an option and is activated by switching the mode switch to the OPT position. This will provide a signal that is intelligible to an AM station.

### 3-16 TRANSADAPT OPTION OPERATION

#### 3-16.1. Receive Station

When the TRANSADAPT option is installed, the radio automatically responds to any correct acquisition packets that are received. The automatic scan is enabled by switch-

ing the channel selector to position 9. With the channel selector in position 9, the radio automatically goes into a fast channel scan, called receive scan. In receive scan, the radio jumps from channel to channel (Manual to 8) listening for an acquisition packet from a transmitting station that contains the receiver's Selcall code or 000 for "all call". The Selcall code is entered into the radio by the switch settings of dip switch S1 on the TRANSADAPT board. If no acquisition packet containing the correct Selcall code or 000 is received after 750 milliseconds, the radio automatically jumps to the next channel. The amount of channels scanned can also be selected (1-9) by the dip switch S2 on the TRANSADAPT board. Refer to the table below for switch settings.

| Scan Limits             |                 |
|-------------------------|-----------------|
| No. of Channels Scanned | Set SW1 Segs ON |
| 3                       | 2               |
| 4                       | 4 2             |
| 5                       | 32              |
| 6                       | 432             |
| 7                       | 1               |
| 8                       | 4 1             |
| 9                       | 3 1             |
| 10                      | 43 1            |

### 3-16.2 Transmitter Station

#### Selcall Code Entry Mode

To call a particular station, the transmitting station must know the Selcall code of the station to be called. This code must be entered so that it can be transmitted with the acquisition packet. To enter the Selcall-Code Entry Mode, hold the digit-select paddle down until a three-digit code is displayed (the digit selected must already be on the right-most digit). Once the three-digit code is displayed, it may be changed using the tune paddle, up for increase, down for decrease. To exit the Selcall-Code Entry Mode, release the digit-select paddle.

#### Mode 1

In Mode 1 of TRANSADAPT, called Selcall, the transmitting station is stationary on any channel other than 9, while the receive station is either stationary on the SAME channel or in Receive Scan (channel 9). The Selcall code of the receive station must already be entered, using the Selcall-Code Entry Mode. To initiate transmission of an acquisition packet, the transmitting station simply holds down the digit-select paddle and pushes the Whip-Tune button (the digit selected must already be the right most digit and the paddle must not be held down for more than 750 milliseconds, or the radio will enter the Selcall-Code Entry Mode). Once initiated, the transmitting station will transmit 8 acquisition packets and listen for a reply after each packet. Before beginning the transmission of acquisi-

tion packets at each channel, the transmitting station verifies that the channel is clear by monitoring the AGC line. If the channel is determined to be acceptable, acquisition packets will then be sent, if not, the radio will merely wait at that channel the usual amount of time and then return to normal operation. If no acknowledgment is received, an audio alarm will be heard in the handset and the radio will automatically return to normal operation, if an acknowledgment is received, an audio "call signal" will be heard in the handset.

#### Mode 2

In Mode 2 of TRANSADAPT, called Scanning Selcall, both the receive and transmit stations are in receive scan (channel 9). To initiate Scanning Selcall, the transmitting station pushes the Whip-Tune button, which enters the radio into a slower scan called Acquisition Scan. In Acquisition Scan, the radio scans each channel, with the total number of channels selected by S2 on the TRANSADAPT board, transmitting 8 acquisition packets and listening each time for a reply at each channel. Transmitting 8 times at each channel allows time for the receiver to complete one complete receive scan cycle to ensure that the receiver has had an opportunity to receive an acquisition packet at each channel. Before beginning the transmission of acquisition packets at each different channel, the transmitting station verifies that the channel is clear by monitoring the AGC line. If the channel is determined to be acceptable, acquisition packets will then be sent. If not, the radio will merely wait at that channel the usual amount of time and then continue in the same manner on the next channel. If there has been no acknowledgment after one complete acquisition scan cycle, an audio alarm will be heard in the handset and the radio automatically returns to receive scan. When the receive station responds, an audio "call signal" will be heard in the handset and both radios will discontinue scanning. Both radios will resume receive scan 1 minute after the last transmission has been sent.

#### Mode 3

TRANSADAPT mode, Mode 3, can be initiated AFTER the transmitting and the receiving stations have previously linked in Mode 2 and are stationary on the same channel. To initiate Mode 3, either the receive or the transmitting station pushes the Whip-Tune button which causes a move packet to be sent. This move packet is sent every 500 milliseconds on the current channel to the other station, for a countdown period of approximately 8 seconds. Each move packet will have a countdown sync number identifying in real time, when the actual move (channel change) will take place. When the other station receives a move packet, it will become synchronized and will move at the same instant as the initiating station. Once the channel change has taken place, the station receiving the move packet will transmit an identifier/sounding packet to the initiating station, which will be used to evaluate the channel path. The initiating station will evaluate the channel path based upon the bit error rate and the AGC level of the identifier/sounding packet. If the path quality meets a minimum criteria, a "channel OK" answer-back packet is sent

from the initiating station to cancel the move operation and an audio "call" signal will be heard in the handsets of both radios. If the path quality does not meet minimum criteria, the move operation will continue until a channel

meets minimum path-quality criteria. If no channels meet minimum path-quality criteria, the move operation will continue back to the original channel and resume normal receive scan operation.

## CHAPTER 4 OPERATOR'S MAINTENANCE INSTRUCTIONS

### 4-1. Scope of Maintenance

This chapter lists the operator's maintenance instructions for the PRC1099. No tools or test equipment are required.

#### NOTE

Replacement of the battery is covered in paragraph 2-4.

### 4-2. Preventive Maintenance

Preventive maintenance is the systematic care, servicing and inspection of the equipment to prevent the occurrence of trouble, to reduce downtime, and to ensure that the equipment is serviceable.

a. **Systematic Care** - The procedures given in paragraphs 4-4 and 4-5 cover systematic care essential to proper upkeep and operation of the equipment. The cleaning operations (Para. 4-6) should be performed daily when the equipment is in use and weekly when the equipment is in standby condition. The other items must be checked before the equipment is placed in operation, during operation and after shutdown.

b. **Preventive Maintenance Checks and Services** - The preventive maintenance checks and services charts (Para. 4-4 and 4-5) outline functions to be performed at specific intervals. These checks and services are designed to maintain the equipment in good condition. If a defect cannot be remedied by the operator, a higher category of maintenance or repair is required.

### 4-3. Preventive Maintenance - Inspection Periods

a. The daily and weekly maintenance and inspection schedules are listed in paragraphs 4-4 and 4-5. In addition to the routine schedules, the equipment should be reinspected and serviced immediately before and after use.

b. If the equipment is being maintained in a standby condition, the daily (Para. 4-4) and weekly (Para. 4-5) services and inspections should be accomplished concurrently.

### 4-4. Operator's Daily Preventive Maintenance Checks and Services Chart (Below)

| Sequence Number | Item to Be Inspected | Procedure   | Reference                 |
|-----------------|----------------------|---|---------------------------|
| 1               | Completeness         | Check to see that the equipment is complete.  | Para. 1-4                 |
| 2               | Exterior Surfaces    | Remove dust, dirt and moisture from all surfaces and clean frequency window with a soft cloth.  | Para. 4-6                 |
| 3               | Controls             | a. Check all controls for looseness or damage.<br><br>b. During operational check (sequence 5), check the mechanical action of each control for smooth operation. |                           |
| 4               | Battery              | Inspect for leakage, corrosion and swelling.<br><br><i>WARNING: Remove battery when transceiver is not to be used for one or more days.</i>                       | Fig. 2-1<br><br>Para. 2-4 |
| 5               | Transceiver Tuning   | Perform the steps in operational check list.  | Para. 4-8                 |

**4-5. Operator's Weekly Preventive Maintenance Checks and Services Chart (Below)**

| Sequence Number | Item to Be Inspected | Procedure   | Reference |
|-----------------|----------------------|---|-----------|
| 1               | Handset              | Inspect the cable for fraying, cuts, kinks and broken insulation. | Fig. 1-4  |
| 2               | Cloth Items          | Inspect for fraying and tears.                                    | Fig. 2-2  |
| 3               | Antenna              | Inspect for damage, loose fit, and corrosion.                     | Fig. 1-2  |
| 4               | Gasket               | Inspect the gasket on the battery box for damage.                 |           |

**4-6. Cleaning**

Inspect the exterior of the transceiver. The exterior surfaces should be free of dirt, grease and fungus.

- a. Remove dust and loose dirt with a clean soft cloth.
- b. Remove grease, fungus and ground-in dirt from the case using a cloth dampened with trichlorethane.
- c. Remove dust and dirt from plugs and receptacles.
- d. Clean the panel and the control knobs using a soft clean cloth. If the dirt is difficult to remove, dampen the cloth with mild detergent and water.

**CAUTION**

*The fumes of TRICHLORETHANE are toxic. Provide adequate ventilation when using. Exposure to open flame converts TRICHLORETHANE to a highly toxic and dangerous gas.*

**4-7. Visual Inspection**

a. When the radio does not operate correctly, check the following items:

- (1) Switches and controls for correct setting.
- (2) Handset - (check by substitution).
- (3) Antenna for loose connection.
- (4) Battery dead - (check by substitution).

b. If these checks do not locate the problem, proceed to the operational check list (Para. 4-8).

**4-8. Operational Checklist.**

a. General - The operational checklist will help the operator locate the problem quickly. Use the corrective measures to repair the equipment. If this does not work, repair is required at a higher maintenance category. Make sure that a tag is attached to the transceiver reporting the nature of the problem.

b. Procedure - Connect the handset to either audio connector and install an antenna (Para. 2-6).

c. Checklist - Perform the steps given in the following checklist.

| Step | Action  | Normal Indication                         | Corrective Measure   |
|------|---|---|--|
| 1    | Set the VOLUME control to 5.  |   |  |
| 2    | Set CHANNEL switch to check channel.                                      |   |  |
| 3    | Set POWER switch to HI.   | Channel frequency is displayed.           | Reset frequency (Para. 3-2).   |
| 4    | Set and hold FUNCTION switch at LITE.                                     | Display lights.                           | a. Check cover is on power connector.<br>b. Replace battery (Para. 2-4). |
| 5    | Set FUNCTION switch to USB  | Background noise is heard.                | Higher level maintenance required.                                       |
| 6    | Set FUNCTION switch to SQUELCH  | Background noise stops.                   | Higher level maintenance required.                                       |
| 7    | Listen to test signals from a nearby set operating on the same frequency. | Signals are heard loud and clear.         | Check antenna.   |
| 8    | Transmit test signal to a nearby set operating on the same frequency.     | Signals are heard loud and clear.         | Connect handset to other audio connector.                                |
| 9    | Check frequencies of channels 1-9.  | Correct frequencies are shown in display. | Reset frequency (Para. 2-4).   |

## CHAPTER 5 FIELD MAINTENANCE INSTRUCTIONS

### 5-1. Scope of Field Maintenance

a. This chapter covers the field maintenance of the PRC1099 and contains information for performing preventive maintenance on the equipment. A series of tests is given to ensure that the transceiver and accessories are operating correctly.

b. This chapter does not contain information on the replacement and repair of the internal modules in the PRC1099; reference should be made to the TW-PRC1099-MS1 Technical Manual.

### 5-2. Tools and Accessories

- a. Bird Model 43 with 50 W element.
- b. Bird Model 8321 50 W dummy load.
- c. Screwdrivers - #1, #2 Phillips, and Flat Blade.
- d. Cleaning Materials.
- e. Accessories - A complete set of operating accessories.

### 5-3. Notes on Battery

The battery voltage (under transmit load) must be at least 12 V for correct performance to specifications. The PRC1099 is designed to remain operational with battery

voltages as low as 10.5 V. Low battery voltage is indicated by a flashing display. Do not continue to operate the transceiver with the lead-calcium battery when the display flashes or the battery operational life is reduced.

The PRC1099 has much lower battery drain on voice operation than in the CW mode. Do not hold the transmitter key down for more than brief periods.

### 5-4. Maintenance Intervals

The maintenance interval will be determined by the conditions of usage. Equipment that is in daily use under harsh environmental conditions may require maintenance at intervals of one month or even less. In any case, the maintenance schedule and performance checks described in this chapter should be performed on a quarterly basis.

### 5-5. Preventive Maintenance Checklist

See chart below.

### 5-6. Troubleshooting

a. VISUAL INSPECTION - When equipment failure occurs, inspect the equipment carefully for obvious defects.

| Sequence Number | Item to Be Inspected | Procedure  | Reference |
|-----------------|----------------------|--|-----------|
| 1               | Completeness         | Check to see that the transceiver is complete with all accessories.  | Para. 1-6 |
| 2               | Cleanliness          | Check to see that the transceiver is clean.  | Para. 4-6 |
| 3               | Preservation         | Check all surfaces for rust, corrosion and fungus. Remove and spot paint any bare spots on metal surfaces. |           |
| 4               | Operational Test     | Perform all tests in performance checklist.  | Para. 5-7 |
| 5               | Controls             | Check that all controls work smoothly, do not bind, and that the knobs are tight on the shafts.            | Fig. 3-1  |
| 6               | Cables               | Inspect the handset cable for fraying, cuts and damage.  | Fig. 1-4  |
| 7               | Cloth                | Inspect all cloth items for tears, fraying and deterioration.  | Fig. 2-2  |
| 8               | Antennas             | Inspect the antennas for damage, loose fit and corrosion.  | Fig. 1-2  |
| 9               | Display              | Check the frequency display window for cleanliness.  | Para. 4-6 |
| 10              | Modules              | Check that the connectors are in place on all modules.   | Fig. 5-1  |
| 11              | Seals                | Inspect the seals on the transceiver panel, battery box and battery connector.                             | Fig. 5-1  |

Make the following checks:

- (1) Check that the antenna is tight in the mount.
- (2) Check the audio connectors on the transceiver and the handset for dirt and correct seating.
- (3) Check the seating of the battery plug in the battery connector.

**b. BATTERY**

Check that the battery does not require replacement.

**c. ACCESSORIES**

- (1) Ensure that the defect is not caused by an accessory.
- (2) Check the handset by substitution.

**5-7. Performance Checklist**

**NOTE 1**

Many of the performance checks are made between two transceivers. The transceivers are operated with the power switch set to LO. Separate the transceivers so that they will not cause overload.

**NOTE 2**

The CHECK transceiver controls should always be set exactly the same as the TEST transceiver.

**a. ACCESSORIES**

- (1) Install the desired antenna in the antenna mount.
- (2) Connect handset to either audio connector.

**b. CONTROLS - Set the controls as follows:**

- (1) VOLUME control - Set to 5.
- (2) POWER switch - Set to LO.
- (3) MODE switch - Set to USB.
- (4) CHANNEL switch - Set to MAN.
- (5) Set in test frequency (Para. 3-2).

At this point the frequency should be displayed and there should be background noise in the receiver. If these indications are not correct:

- a) Tighten power receptacle cap.
- b) Connect handset to other audio connector.
- c) Check handset by substitution.
- d) Replace battery.

**c. OPERATING CHECK**

(1) Ensure CHECK transceiver is operating on the same frequency with same control settings as the TEST transceiver.

(2) Reception Test - When the CHECK transceiver makes a transmission, the signal should be heard loud and clear.

(3) Transmission Test - When the TEST transceiver makes a transmission, the signal should be heard loud and clear. (Change handset if signal is heard with no audio).

**d. BAND CHECK**

The PRC1099 has six internal frequency bands selected automatically by the microprocessor. The following test ensures that the transceiver is operating on all bands.

- (1) Repeat test C on any frequency 1.6-3.099 MHz
- (2) Repeat test C on any frequency 3.1-5.099 MHz
- (3) Repeat test C on any frequency 5.1-7.999 MHz
- (4) Repeat test C on any frequency 8-12.999 MHz
- (5) Repeat test C on any frequency 13-19.999 MHz
- (6) Repeat test C on any frequency 20-24.999 MHz

**NOTE**

The original test frequency will be in one of the six ranges and the test in this range need not be repeated.

**e. SQUELCH CHECK**

- (1) Set the MODE switch to SQUELCH.
- (2) The CHECK transceiver makes a transmission.
- (3) The signal should be received loud and clear.

**f. LSB**

- (1) Set the MODE switch to LSB.
- (2) Repeat Operating Check steps 1-3.

**g. LIGHT TEST**

- (1) Turn the FUNCTION switch to LITE.
- (2) The frequency display should light.

**h. POWER TEST**

- (1) Remove the antenna and mount.
- (2) Connect the wattmeter to the BNC antenna connector.
- (3) Select any frequency.
- (4) Set the power switch to HI.
- (5) Connect CW key. Press key and measure power output.
- (6) Repeat step 5 at LO power.

The nominal power output is:

- High: 20 W
- Low: 5 W

**NOTE**

The power output is 20 W PEP (peak envelope power) on voice operation and requires the use of a peak measuring device such as an oscilloscope. It is normal for the power meter reading to read 20-40% of normal during voice operation. The meter should indicate correct power output on CW.

**i. MEMORY CHECK**

- (1) Switch the transceiver channel switch through channels 1-9.
- (2) The correct frequencies should be displayed.

**NOTE**

The PRC1099 uses a small internal battery to store the channel frequencies and is not dependent on the main battery. The internal battery has a life of approximately ten



years. In the event of a failure of the memory battery the transceiver remains operable but will not retain memory when the power is turned off.

j. AME option.

- (1) Set MODE switch to OPT.
- (2) Repeat Operating Check steps 1-3.

### 5-8. Internal Inspection of the PRC1099

a. Stand the PRC1099 on its front panel (Figure 2-1). Remove the battery case and the battery (Para. 2-4 a, b and c). Loosen the captive screws and pull the case from the chassis. (Figure 5-2).

b. Inspect the battery connector for the following:

(1) A rubber gasket (shaped similarly to the metal ring around the battery connector hole in the PRC1099 case) must be installed on the battery connector. Check to make sure that it is not damaged. It must be seated flush with the bottom of the connector (inside the four connector mounting screws) and flush with the body of the connector.

(2) The two O-rings on the battery connector must be installed and not damaged. That is, they must not be sheared; and each O-ring must be sealed, under tension, in its recess.

(3) The four battery connector pins must not be bent or otherwise damaged.

c. Inspect the connectors on all transceiver modules. Ensure that the pin connectors are locked firmly in place.

d. Inspect the seals on the front panel and the base of the transceiver. The seals should be clean and free from cuts, dirt, or nicks. Inspect the top edge of the case and the battery box. These edges must be smooth and free from dents or nicks. The front panel and battery case seals must be in good order to ensure that the transceiver is waterproof.

e. The pressure test screw in the battery box must be securely sealed. The hole is used for pressure testing of the case.

f. Check that the pressure relief valve is screwed tightly in place. This valve will vent any gas generated by the battery.

### 5-9. Frequency Calibration

The PRC1099 operates in the single sideband mode, and precise frequency calibration is required for correct operation. If the speech sounds garbled and off tune, increment the TUNE switch up and down to fine tune the receiver. If the speech clarity improves when the receive frequency is offset, then either one of the test transceivers requires frequency calibration. This is an internal adjustment and requires the use of an accurate frequency counter.

## CHAPTER 6

# HF COMMUNICATIONS & SINGLE SIDEBAND

### 6-1. Introduction

This section of the manual contains information on the single sideband mode and high frequency communications. This information will help the operator use the PRC1099 to provide more effective communications.

### 6-2. Single Sideband

The PRC1099 provides voice communications in the single sideband mode (SSB). This mode provides more efficient operation for high frequency communications than the FM (frequency modulation) mode used for tactical communications in the 30-88 MHz range. SSB has now almost completely replaced the earlier AM (amplitude modulated) mode and provides a major advantage for HF communications. The SSB transmitter uses special circuitry to suppress the carrier and one of the two sidebands of an AM signal. This gives a sixfold increase in efficiency, as the carrier uses 2/3 of the power and carries no useful information; and the two sidebands contain identical information. This means that the SSB transmitter puts all of the power into one information carrying sideband. This makes the PRC1099 as effective as a 120 W AM transmitter.

Apart from the improved efficiency, the SSB signal occupies less than half the frequency space of the AM signal and permits much better utilization of the crowded HF spectrum. The SSB signal is more intelligible at poor signal levels and is far less affected by selective fading and interference. To receive SSB, it is necessary to use a special receiver that locally reinserts the suppressed carrier so that the transmission may be demodulated. The SSB signal sounds quite unintelligible when received with a standard AM receiver.

### 6-3. HF COMMUNICATIONS

The high frequency (HF) communications spectrum is primarily used for long distance communications, while VHF is favored for local communications. If the correct frequencies and antenna systems are used, the HF spectrum will provide effective communications over almost any distance including inter-continental ranges. There are two main modes of propagation of HF signals - ground wave and sky wave. The ground wave follows the surface of the earth and provides reliable signals over short ranges. The signals are attenuated very rapidly as they pass over the surface of the earth, so that high powers and good antennas are essential for good ground wave coverage. The ground wave attenuation increases as a function of frequency, and the lower frequencies below 3 MHz are favored for ground wave operation.

This mode may be the only effective method for local coverage in areas too mountainous for VHF and UHF operation.

Most HF communication is by sky wave where the signals are refracted by the reflecting layers of the ionosphere. Long distances can be covered with little signal attenuation provided the correct frequency is chosen. The ionosphere does not stay constant; it varies with the time of day, time of year, the sun spot cycle and the activity of the sun. Solar flares can cause complete radio blackouts with little warning. HF communications are affected by static caused by lightning; sometimes from storms many hundreds or thousands of kilometers away. A clear channel can never be assured, as long distance propagation may cause strong interfering signals on the frequency from great distances. It must always be understood that although long distance communications are possible with low powers and simple antennas, high reliability and freedom from interference is not possible. In spite of the problems, a surprisingly good standard of communications can be achieved provided that care is taken to select the correct frequency and to use good equipment with an efficient antenna system.

The correct choice of frequency is beyond the scope of this manual and may be limited by the available frequency allocations. The following information may give a starting point in choosing the best frequency. Remember that the final guide should be an actual test, as often only a small change in frequency may make a big difference in signal strength.

The low frequencies, below 3 MHz, will normally be restricted to short ranges during the day. At night, longer ranges (3-400 kilometers) are possible, but interference and static may be major problems. Good antennas and high power are essential for anything but the shortest distances.

The medium frequencies from 3-5 MHz may be a good choice for moderate distances (3-400 kilometers) during the day. At night, considerable distances are possible, although static will be a frequent problem during summer months. The physical length of a good antenna is still quite long, and it is difficult to achieve good efficiencies with whip antennas in this range.

The medium frequencies from 5-11 MHz are the most popular for communications up to 1000 kilometers. Good ranges are possible during the day with the higher frequencies being favored for the longer distances. Communications may become more difficult at night with interfering signals from all over the world.

The higher end of the spectrum, above 12 MHz, is favored for long distance communications. The propagation will be severely affected by the ionosphere and expert advice is essential in choosing the correct frequencies for long distance operation. For example, frequencies as high as 30 MHz may be used for worldwide communica-

tions during the peak of the sunspot cycle. However, during periods of low sunspot activity, this frequency range will be completely dead. It is important to remember that at the higher frequencies there can be skip zones; and a strong signal may be received from 2000 kilometers away, while closer stations cannot be heard.

## CHAPTER 7

# ANTENNA SYSTEMS

### 7-1. Introduction

In the manpack configuration the PRC1099 is limited to use with the whip antenna. This antenna is very short compared with a resonant antenna on most frequencies in the HF range and must be artificially matched by the antenna tuner. The whip antenna operates against ground, and in the manpack configuration the ground is provided by the capacitance of the operator's body. The combination of the short antenna, lossy ground, and inefficiencies in the matching system severely restrict the range of the equipment in the manpack configuration. A major improvement in performance is possible by using longer whip or wire antennas and a better ground system. For maximum ranges, the resonant antennas provide superior performance.

### 7-2. Internal Antenna Tuner

The internal antenna tuner will match the 10 ft whip antenna from 2-30 MHz. The following antennas may be matched over the 1.6-30 MHz frequency range:

Whips - 16 ft, 24 ft, and 32 ft.  
Long Wire - 25 ft, 50 ft and 100 ft.

The whip or long wire antennas must be connected to the special adapter, LWA. The antenna tuner will not operate unless the adapter is used. The antenna tuner will also match random length long wire antennas (exceeding 50 ft) on most operating frequencies. In an emergency, the long wire may be attached to the top of the AT-271A support and will tune on most frequencies..

### 7-3. Ground Systems

The end fed whip or long wire antennas will only operate at maximum efficiency when used with a perfect ground system. In the manpack configuration the ground is capacitively coupled through the operator's body and almost all of the output power is absorbed by the lossy ground system. This is the major reason for the poor performance of HF manpacks. Even placing the transceiver directly on the ground will give some improvement in efficiency. If possible, a separate ground system should always be used. The transceiver ground terminal should be connected directly to the ground by using the shortest possible wire. The ground can be a ground stake in moist soil or a water pipe going into the ground. A counterpoise system using as many radial wires as possible will improve performance even if there is no direct connection to ground. A direct connection to a vehicle body provides another effective counterpoise system. Even a single wire laid on the ground or a connection to any mass of metal such as a wire fence will improve the transceiver performance.

### 7-4. End-Fed Antennas

The end fed antenna is usually erected as a vertical whip or a long wire. The whip should be connected directly to the antenna terminal using a short connecting lead. One end of the long wire antenna is connected to the antenna terminal. The long wire can be erected part vertical and part horizontal, or in a sloping configuration. Almost any support such as trees or buildings will work. Even compromise installations where the antenna is draped over hedges or let out of a window can work and usually outperform the manpack configuration. The antenna does not even have to be in a straight line. The important consideration is to try and keep the radiating part of the antenna as high and in the clear as possible.

#### a. 50-OHM ANTENNAS

When the adapters are removed from the antenna post, the antenna tuner is disconnected and the output is switched to the BNC antenna connector. Any 50 ohm coaxial fed antenna with a VSWR of less than 3:1 (preferably 2:1) can be used with the PRC1099.

(1) Resonant Dipole. The resonant half wave dipole is a simple, efficient antenna providing good long range coverage, even with the limited power of the packset. The length of the antenna must be adjusted for the frequency of use. See Figure 7-3.

(2) Broadband Antennas. The ABB100A and ABB100B antennas offer good performance, without adjustment over the 2-30 MHz frequency range. See Figure 7-4.

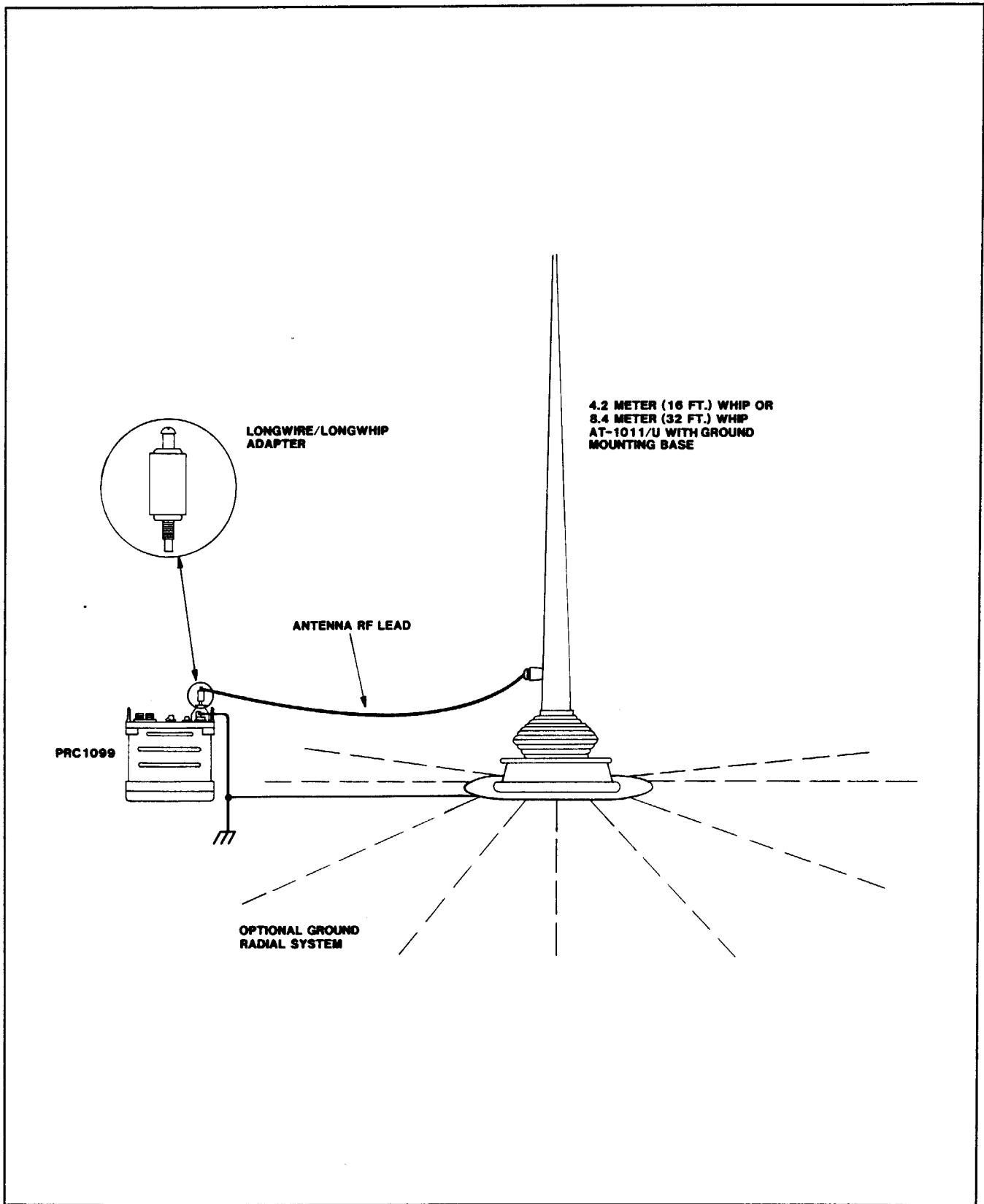
(3) Directional Antennas. Directional Antennas are used for long range communications. Rotatable arrays provide coverage in all directions while fixed antennas are used for operation in specific directions. Some directional antennas are restricted to single frequency operation; while other arrays, such as the log periodic, can be used over a wide frequency range.

#### b. REMOTELY-TUNED ANTENNAS

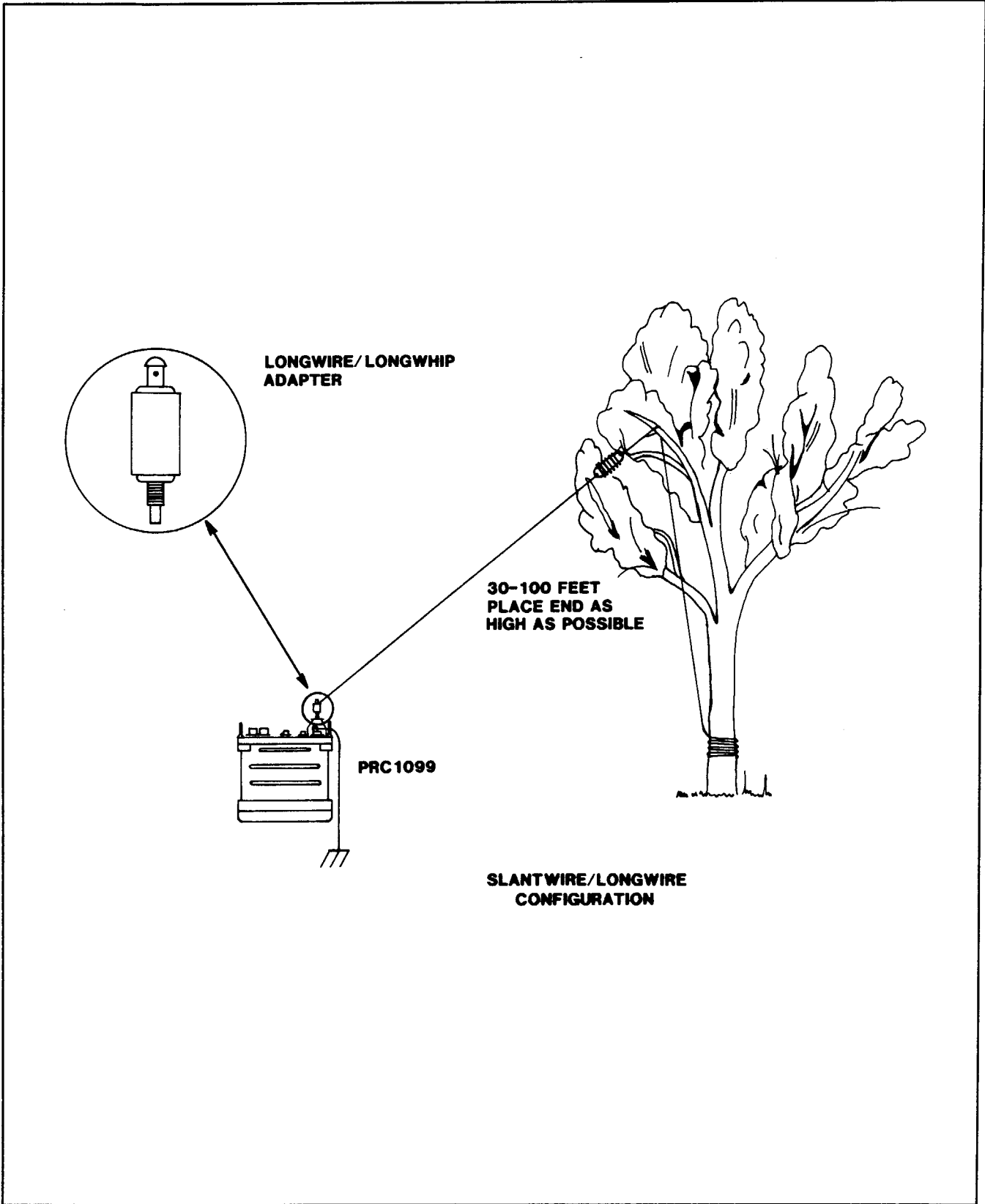
The PRC1099 has provision for the operation of the RAT100 Automatic Antenna through a multiwire control cable and 50 ohm coaxial RF cable. The tuner may be located at the antenna and is particularly convenient for mobile installation. The tuner is rated at 125 W and can be used with the RA100, 100 W amplifier.

#### NOTE

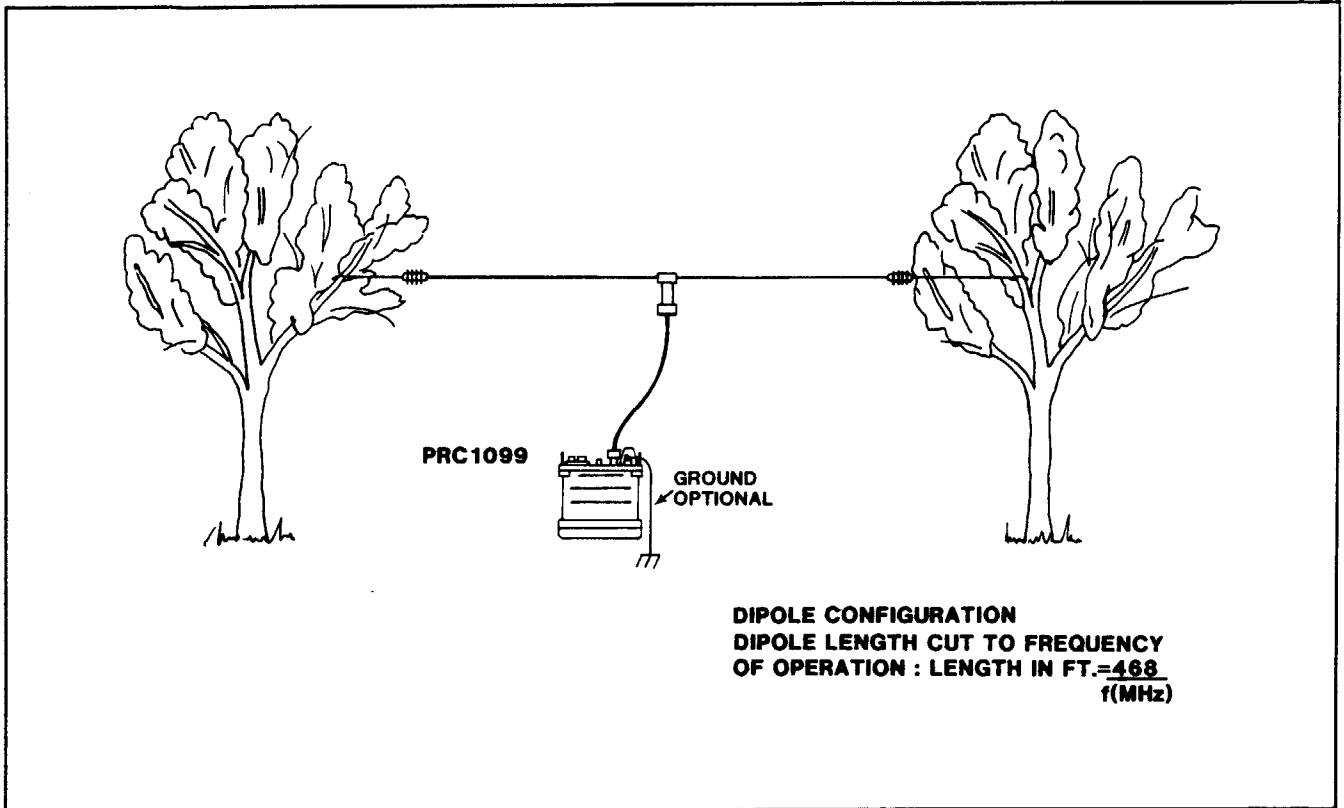
The RAT100 should be used with a separate 12 V supply source.



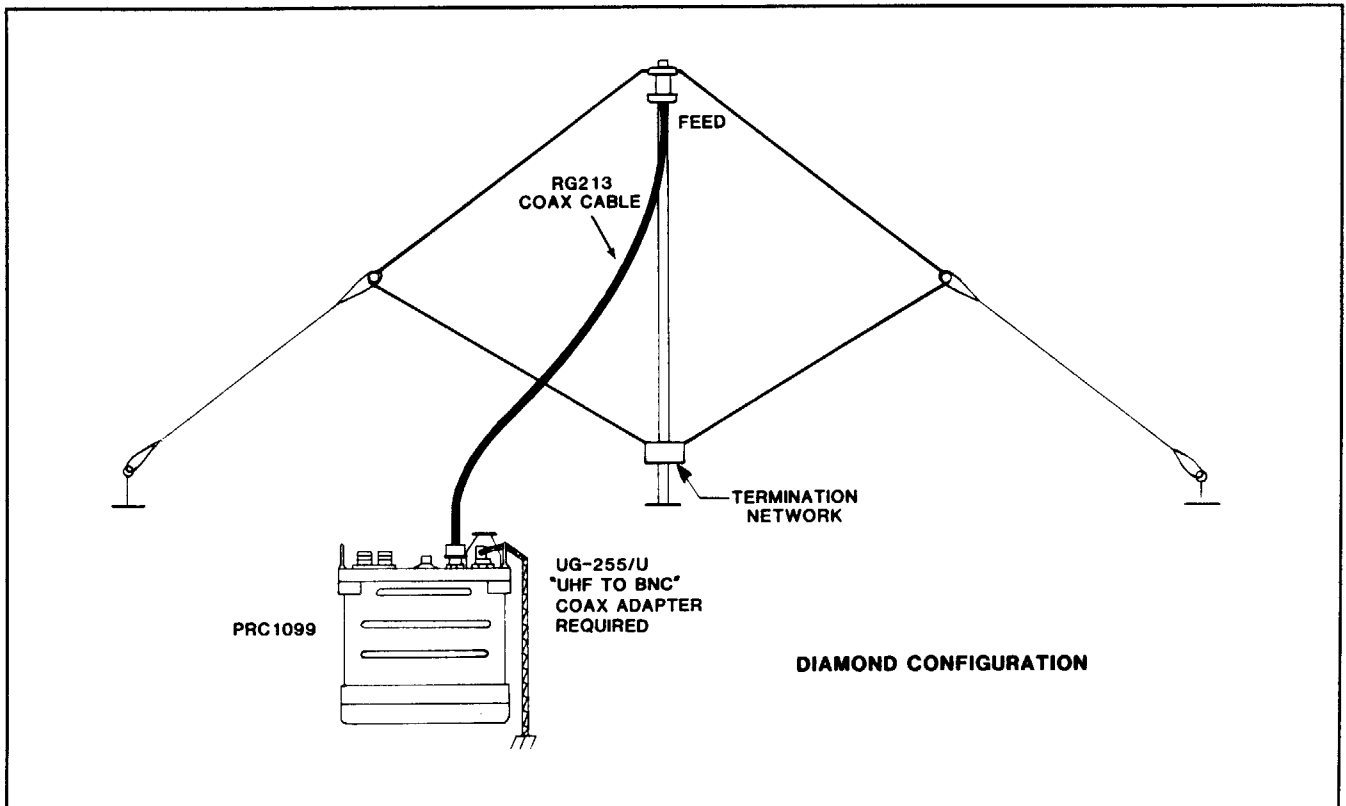
**FIGURE 7-1.**  
Whip Antenna Configuration.



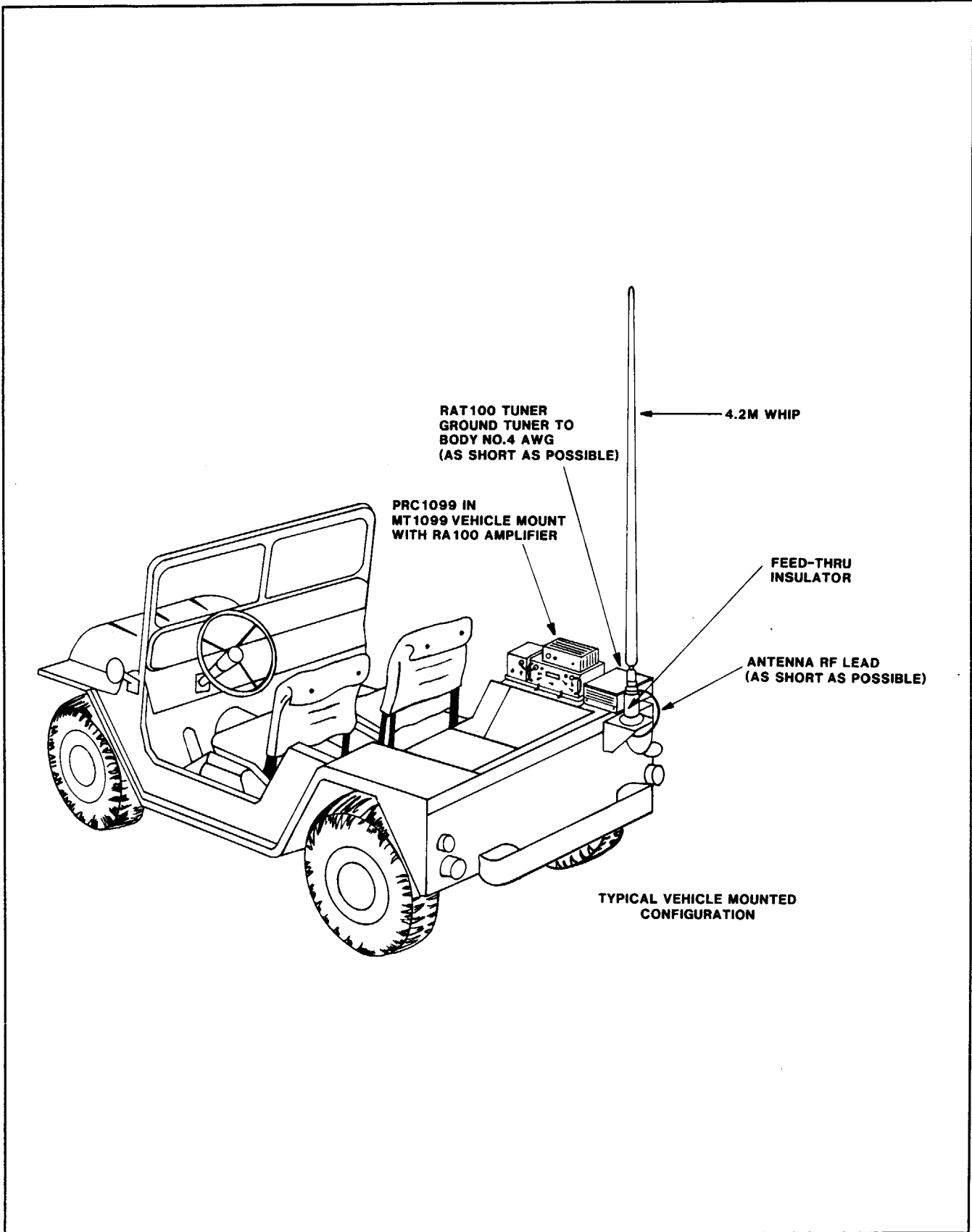
**FIGURE 7-2.**  
**Slant Wire/Long Wire Antenna Configuration.**



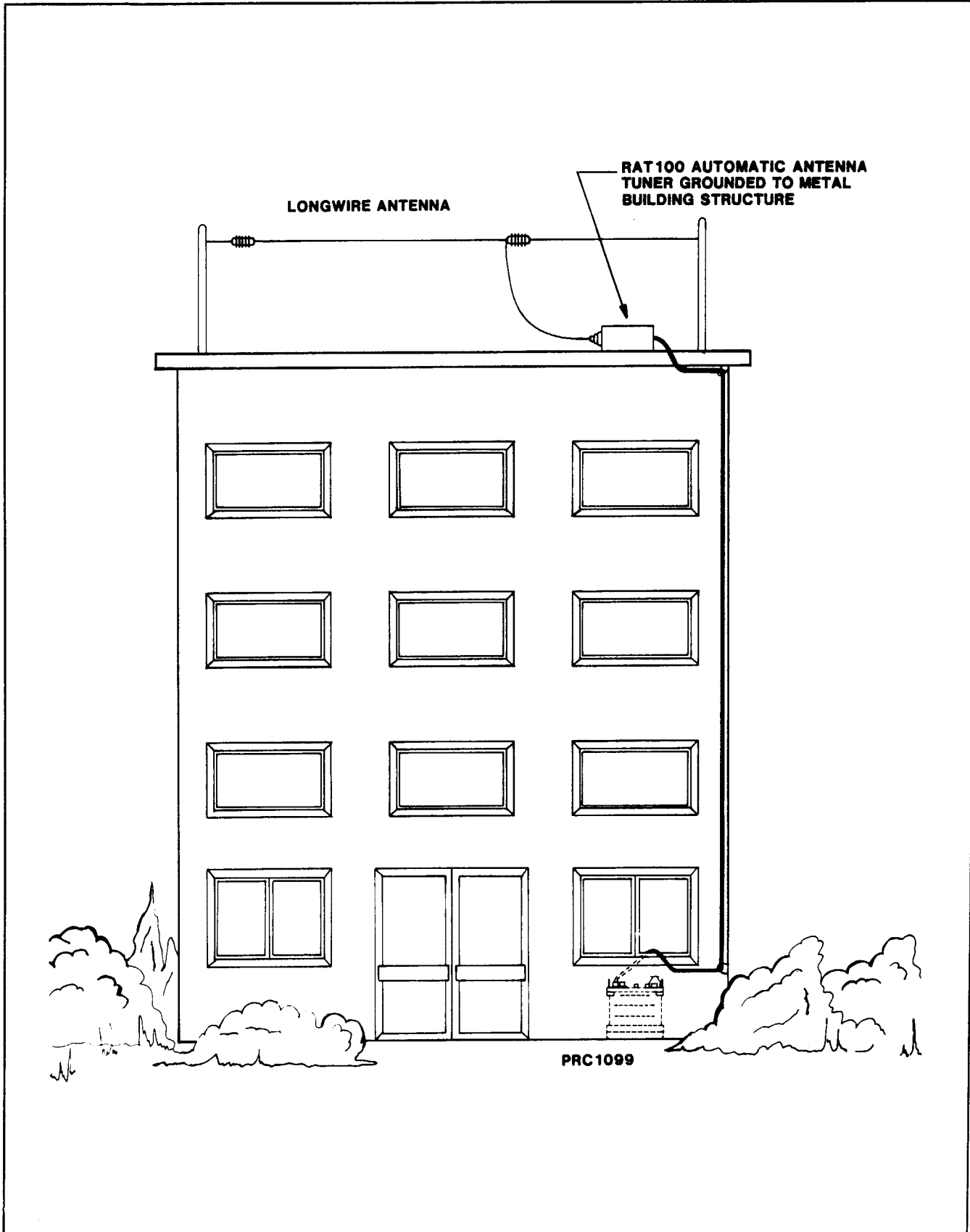
**FIGURE 7-3.**  
**Resonant Dipole Antenna Configuration.**



**FIGURE 7-4.**  
**Broadband Antenna Configuration.**



**FIGURE 7-5.**  
**Mobile Configuration with Remote Antenna Tuner.**



**FIGURE 7-6.**  
**Remote Tuned Antenna Configuration.**

## APPENDIX A ORGANIZATIONAL REPAIR PARTS

### A-1. General

This appendix contains a list of repair parts required for the performance of organizational maintenance for Radio Set PRC1099.

#### NOTE

No special tools, test or support equipment are required.

### A-2. Explanation of Columns

An explanation of columns in Table A-1 is given below.

#### a. Stock Number, Column 1.

The manufacturer's stock number for the item is indicated in this column.

#### b. Description, Column 2.

The item name and military part number (if used) are included in this column.

#### c. Unit of Issue, Column 3.

The unit used as a basis of issue (e.g. ea, pr, ft, yd, etc.) is indicated in this column.

#### d. Quantity Incorporated in Unit, Column 4.

The quantity of repair parts in an assembly is given in this column.

#### e. Illustrations/Figure Number, Column 5.

The number of the illustration in which the item is shown in this manual is indicated in the column.

### A-3. Location of Repair Parts

a. When the stock number is unknown, follow the procedures given in (1) through (3) below:

1. Use the table of contents to locate the appendix of the repair parts list.

2. If the item and figure number is not known, check the description column (column 2) in the repair parts list to locate the part.

3. Locate the applicable illustration in this manual and note the figure number. Use the repair parts listing and locate the figure number as noted on the illustration.

b. When the stock number is known, use the repair parts listing to find the repair part and figure number.

**TABLE A-1.  
Repair Parts for Organizational Maintenance.**

| (1)              | (2)                                      | (3)           | (4)              | (5)                             |
|------------------|--|---------------|------------------|---------------------------------|
| TWC STOCK NUMBER | DESCRIPTION                              | UNIT OF ISSUE | QTY INC. IN UNIT | ILLUSTRATIONS-<br>Figure Number |
| PRC1099          | Radio Set                                |               |                  | 1-2                             |
| 894102           | Battery Box, CY-2562                     | ea            | 1                | 1-2                             |
| 894104           | Case, transceiver                        | ea            | 1                | 2-1                             |
| 610080-A         | Cover, double rubber connector protector | ea            | 1                | 5-1                             |
| 610085           | Dummy Connector, plug                    | ea            | 1                | 5-1                             |
| 610087-A         | Cover, antenna dust                      | ea            | 1                | 5-1                             |
| 610088           | Cover, BNC                               | ea            | 1                | 5-1                             |
| 891027           | Knob - long handled (MHz & kHz tuning)   | ea            | 2                | 5-1                             |
| 891027           | Knob - long handled (power switch)       | ea            | 1                | 5-1                             |
| 891027           | Knob - long handled (function switch)    | ea            | 1                | 5-1                             |
| 891027           | Knob - long handled (channel switch)     | ea            | 1                | 5-1                             |
| 891028           | Knob (volume)                            | ea            | 1                | 5-1                             |
| CFH              | Harness, Electrical Equipment ST-138     | ea            | 1                | 1-2                             |
| ACB              | Bag, Cotton Duck CW-503                  | ea            | 1                | 1-3                             |
| AT-271A          | Antenna, 10 ft. Folding Whip (AT-271A)   | ea            | 1                | 1-2                             |
| AB-591           | Support Antenna for AT-271A              | ea            | 1                | 1-2                             |
| MHS              | Handset, H-250/U                         | ea            | 1                | 1-4                             |

## APPENDIX B OPTIONAL ACCESSORY EQUIPMENT

### B-1 General

This Appendix contains a list of optional accessory items for radio set PRC1099 in Table B-1. It also includes instructions for using the major accessory items with the PRC1099.

### b. Description, column 2.

The item name and military part number (if used) are included in this column. Accessories are grouped in categories to assist in locating items of interest.

### B-2 Explanation of Columns

An explanation of columns in Table B-1 is given below.

### c. Unit of issue, column 3.

The unit used as a basis of issue (e.g. ea, pr, ft, yd etc) is located in this column.

### a. Stock number, column 1.

The manufacturer's stock number for the item is indicated in this column.

### d. Quantity used in (or with) unit, column 4.

The quantity of items used per radio/system is indicated in this column.

**TABLE B-1.  
Optional Accessory Equipment.**

| (1)                    | (2)   | (3)                 | (4)                     |
|------------------------|---|---------------------|-------------------------|
| TWC<br>STOCK<br>NUMBER | DESCRIPTION   | UNIT<br>OF<br>ISSUE | QTY<br>USED PER<br>UNIT |
|                        | <b><u>BATTERIES</u></b>   |                     |                         |
| BB-LA6:                | Sealed lead-calcium rechargeable battery (6 Ah).  | ea                  | 1                       |
| BA6598/U:              | BA6598/U high-capacity lithium battery (14 Ah).   | ea                  | 1                       |
| BB-NC4:                | "D"-cell battery cassette for dry batteries or "D" nicad cells.<br>NOTE: Only usable at 5-W power level with "D" dry batteries.<br>Cassette only does not include batteries.  | ea                  | 1                       |
|                        | <b><u>BATTERY CHARGERS/POWER SUPPLIES</u></b>   |                     |                         |
| PRC-PS:                | Power supply//battery charger for sealed lead-calcium battery pack. Will operate radio while charging internal battery. Automatic rapid/taper charge characteristic; 115/230-Vac input. Separate charger circuit charges spare battery. | ea                  | 1                       |
| PRC-BC4:               | Multiple battery charger. 115/230-Vac, 24-Vdc input power. Charges up to 4 BB-LA6 lead-calcium battery packs simultaneously. Automatic rapid/taper charge characteristic. Individual charge status indicators.                          | ea                  | 1                       |
| PRC-SPU-10:            | Solar power generator for charging sealed lead-calcium battery pack. Portable, rugged unit can supply 10-W output.  | ea                  | 1                       |
| PRC-HC-30:             | Portable hand-crank generator used for charging nicad or lead-calcium batteries. Rugged, compact unit that can supply 30-W output.  | ea                  | 1                       |
| PRC-HC-8:              | Portable hand-crank generator used for charging nicad or lead-calcium batteries. Rugged, compact unit that can supply 8-W output.   | ea                  | 1                       |

**TABLE B-1.  
Optional Accessory Equipment, Continued.**

| (1)              | (2)   | (3)           | (4)               |
|------------------|---|---------------|-------------------|
| TWC STOCK NUMBER | DESCRIPTION   | UNIT OF ISSUE | QTY USED PER UNIT |
|                  | <b><u>POWER CABLES</u></b>  |               |                   |
| PRC-CA12V:       | 12-V power cable allows operation of radio from 12-V source. Allows charging of lead-calcium BB-LA6 battery pack on radio direct from 12-V vehicle charging system. 12-V systems only—no lithium or dry battery charging.   | ea            | 1                 |
|                  | <b><u>CARRYING ACCESSORIES</u></b>  |               |                   |
| ST-138:          | Standard military carrying harness with shoulder straps, frame, and securing straps for PRC1099.  | ea            | 1                 |
| CW-503:          | Accessory carrying bag. For PRC1099 antennas and handset. Attaches to ST-138 carrying harness.  | ea            | 1                 |
|                  | <b><u>AUDIO ACCESSORIES</u></b>   |               |                   |
|                  | All PRC1099 audio accessories are terminated with twist-lock mil-spec connectors. Audio accessories which have color coding may only be connected to the front-panel 6-pin audio connector with the matching color code. If one of the front-panel audio connectors is not color coded, that connector accepts noncolor-coded audio accessories. The appropriate audio connector (left (L) or right (R)) is shown here next to "Qty Used Per Unit." |               |                   |
| RCH              | RCH remote-control handset. Allows remote PTT, Earphone Volume and Channel Select Control Non-noise cancelling.   | ea            | 1 (R)             |
| H-250/U:         | H-250/U military handset. Noise-cancelling.   | ea            | 1 (L,R)           |
| H-189/U:         | H-189/U military handset. Nonnoise-cancelling.  | ea            | 1 (L,R)           |
| H-80/U:          | M-80/U ruggedized hand microphone.  | ea            | 1 (L,R)           |
| H3M:             | Headset-boom microphone. Single earphone low profile—will fit under GI Kevlar helmet with clip-on push-to-talk switch.  | ea            | 1 (L,R)           |
| H-140/U:         | H-140/U ruggedized headphones with 5-pin mil-spec connector.  | ea            | 1 (L,R)           |
| KYR:             | Morse key with 36-in cord and 5-pin mil-spec connector.   | ea            | 1 (L)             |
| LS-R:            | Loudspeaker, allows loudspeaker monitoring of PRC1099 radio.  | ea            | 1 (L,R)           |

**TABLE B-1.  
Optional Accessory Equipment, Continued.**

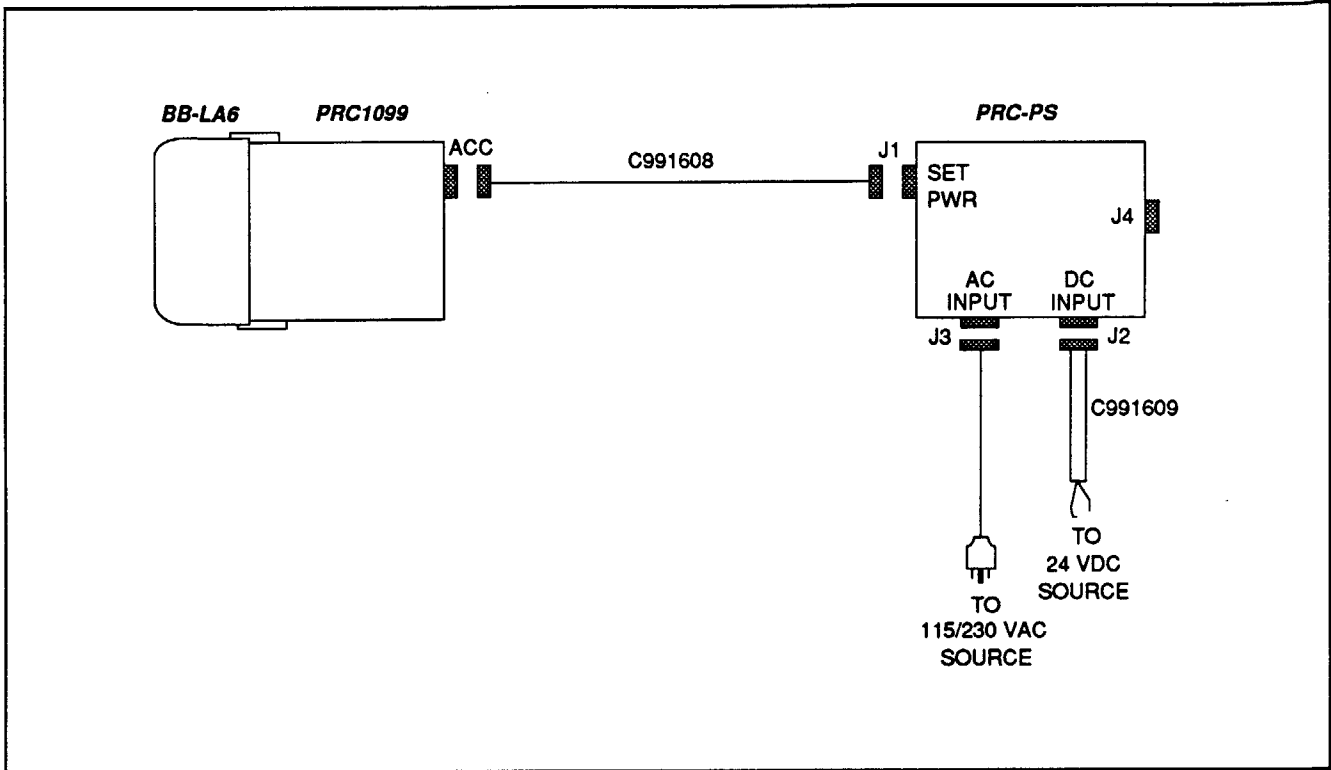
| (1)                     | (2)  | (3)                 | (4)                     |
|-------------------------|--|---------------------|-------------------------|
| TWC<br>STOCK<br>NUMBER  | DESCRIPTION  | UNIT<br>OF<br>ISSUE | QTY<br>USED PER<br>UNIT |
|                         | <p align="center"><b><u>ENCRYPTION AND CODED SIGNALLING ACCESSORIES</u></b></p> <p>Note the possibility of color-coded connectors, as described under "Audio Accessories."</p>               |                     |                         |
| PRC-SELCALL             | PRC-SELCALL. high-speed selective-calling unit with internal modem.  | ea                  | 1 (L)                   |
|                         | <p align="center"><b><u>MANPACK AND LONG-RANGE ANTENNAS</u></b></p>  |                     |                         |
| AT-271A/U-<br>AB-591/U: | AT-271A/U 3-m folding whip antenna with AB-591/U flexible antenna base.  | ea                  | 1                       |
| ATD:                    | Adjustable stainless steel tape halfwave dipole with 45 ft RG-58/CU feedline.  | ea                  | 1                       |
| ALD:                    | Lightweight tactical dipole kit with 30 ft RG-58/CU feedline and erection lines.   | ea                  | 1                       |
| ALW:                    | Ruggedized longwire antenna kit. Includes 100 ft antenna wire on bobbin insulator, hang-up cord and counterpoise/ground stake. Longwire adapter for whip antenna socket also provided.       | ea                  | 1                       |
| AGK:                    | Grounding kit—2 wire braided 50 ft each, counterpoise/ground stake to enhance efficiency with short antennas.  | ea                  | 1                       |
| AAW:                    | Whip adapter and feedwire used for direct connection of PRC1099 to either RA-MAS and RA-PAS. Not required when external automatic antenna tuner is used.                                     | ea                  | 1                       |
| RA-MAS:                 | Mobile antenna system, comprised of 120-16 4.8-m, 4-section fiberglass military whip, 120-43 mobile base, and RMB mobile mounting bracket. Requires antenna tuner.                           | ea                  | 1                       |
| RA-MSS:                 | Mobile antenna system. As above except includes 4245 locking rigidized spring base for heavy duty use.   | ea                  | 1                       |
| RA-PAS:                 | 9.6 m (32 ft) fiberglass ruggedized-type whip with flange base, side feed.   | ea                  | 1                       |
| ABB100A:                | Broadband folded loop dipole 2-30 MHz, 45.7 m long. Optimized for 2-10 MHz performance. Supplied with 15 m RG-213/U coaxial cable feedline. For semi-permanent applications (mast required). | ea                  | 1                       |

**TABLE B-1.  
Optional Accessory Equipment, Continued.**

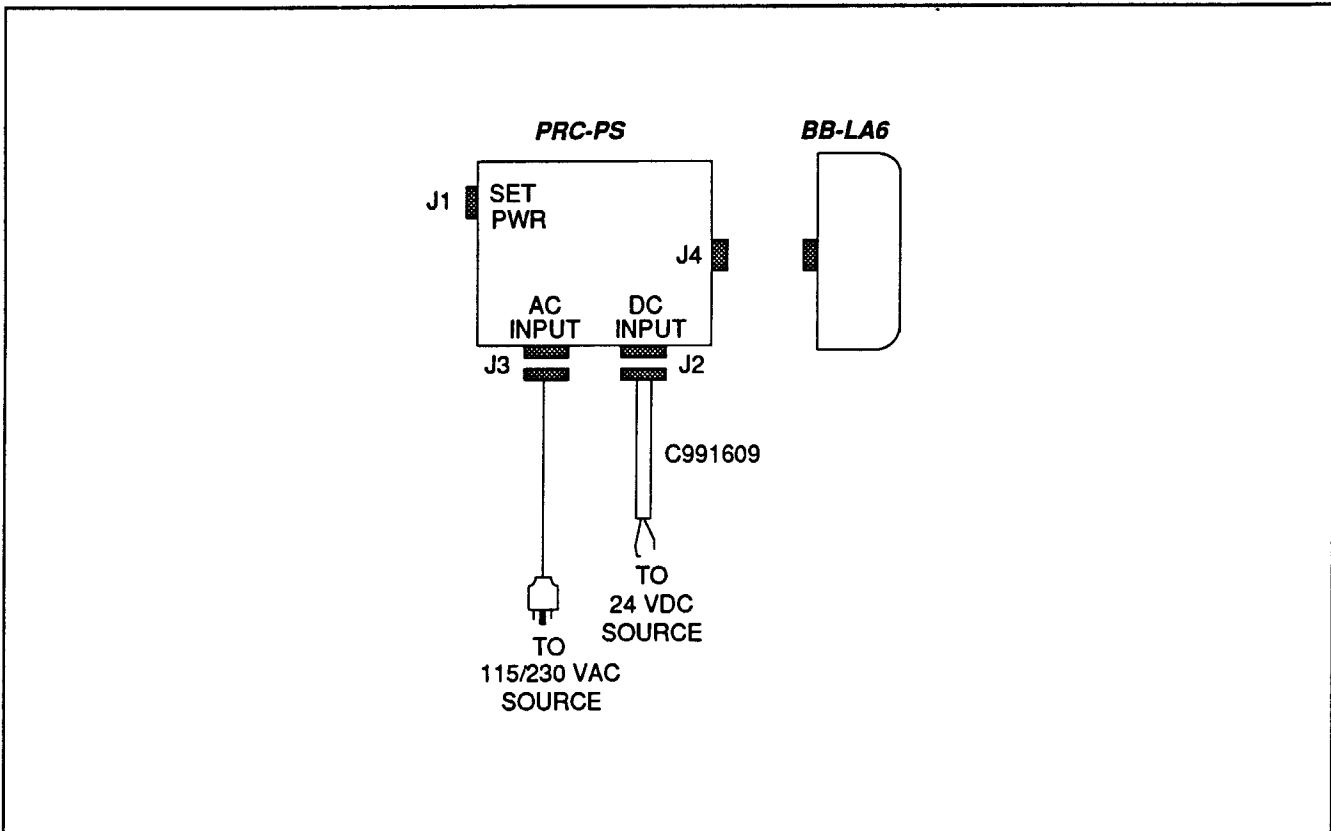
| (1)                    | (2)  | (3)                 | (4)                     |
|------------------------|--|---------------------|-------------------------|
| TWC<br>STOCK<br>NUMBER | DESCRIPTION  | UNIT<br>OF<br>ISSUE | QTY<br>USED PER<br>UNIT |
|                        | <b><u>MANPACK AND LONG-RANGE ANTENNAS (Continued)</u></b>  |                     |                         |
| ABB100B:               | Broadband folded loop dipole 2-30 MHz. Short model 27.4 m long. Supplied with 15 m RG213/U coaxial cable feedline. For semi-permanent applications (mast required).  | ea                  | 1                       |
| AMX:                   | Portable antenna mast kit for ABB100 and ABB1000 series antennas. Includes 48 ft of mast sections, guy rings, dacron rope guys, guy stakes, mast base, raising halyard rope and pully supplied in canvas carrying bag with guy hammer.   | ea                  | 1                       |
|                        | <b><u>AMPLIFIERS AND POWER SUPPLIES</u></b>  |                     |                         |
| RA100-12:              | 100-W RF power amplifier 1.6-30 MHz. Ruggedized package compatible with MT-1099 vehicle adapter mount and PRC1099 manpack transceiver. Transceiver operates from nominal 12-Vdc power source. Order C991575 RF cable and C991585 control cable separately.                               | ea                  | 1                       |
| RA100-24:              | 100-W RF power amplifier 1.6-30 MHz. Same as RA100-12, except operates from nominal 24-Vdc power source. Order C991575 RF cable and C991585 control cable separately (Figure B-9).   | ea                  | 1                       |
| RA400-99:              | 400-W RF power amplifier. 1.6-30 MHz medium power tactical amplifier for PRC1099 manpack transceiver. Designed for continuous duty applications. Fully immersible. Order C991510 RF cable and C991509 control cable separately (Figure B-10).  | ea                  | 1                       |
| RA1000-99:             | 1000-W RF power amplifier 1.6-30 MHz base station or mobile high-power amplifier for PRC1099 manpack. Requires 100-W RA100 amplifier as a driver unit. Designed for continuous duty applications in a rugged tactical environment. Order RF and control cables separately (Figure B-11). | ea                  | 1                       |
| UPS100-12:             | 115/230-Vac power supply for RA100-12. Also supplies power for PRC1099 driver unit.  | ea                  | 1                       |
| UPS100-28:             | 115/230-Vac power supply for RA100-28. Also supplies power for PRC1099 driver unit.  | ea                  | 1                       |
| UPS500:                | 115/230-V power supply for RA400-99. Also supplies power for PRC1099 driver unit.  | ea                  | 1                       |
| UPS1000:               | 115/230-V power supply for RA1000-99. Also supplies power for PRC1099 driver unit.   | ea                  | 1                       |

**TABLE B-1.  
Optional Accessory Equipment, Continued.**

| (1)              | (2)   | (3)           | (4)               |
|------------------|---|---------------|-------------------|
| TWC STOCK NUMBER | DESCRIPTION   | UNIT OF ISSUE | QTY USED PER UNIT |
|                  | <b><u>ANTENNA TUNERS</u></b><br>(Supplied less interface cables. Order cables as indicated).  |               |                   |
| RAT20            | 25-W automatic digital antenna tuner—used with PRC1099 to locate the radiating antenna away from the radio operator. May be used with dipoles, longwires, NVIS, and other antennas.   | ea            | 1                 |
| RAT100-99:       | 125-W automatic digital antenna tuner—used with RA100 amplifiers for mobile, marine, fixed and portable installation using whip and long-wire antennas. Order cables separately. (Fig. B-9).  | ea            | 1                 |
| RAT400-99:       | Automatic digital antenna tuner 400 W used with RA400-99 amplifier. For mobile (3-30 MHz) and marine, fixed or portable (2-30 MHz) installations. Provides automatic high-speed (digital) tuning on receipt of actuation signal from PRC1099 transceiver. Operates with whip and longwire antennas. Order cables separately (Figure B-10).                  | ea            | 1                 |
| RAT1000-99:      | 1000-W automatic digital antenna tuner. Same as RAT400-99 with additional cooling fan. Order cables separately (Figure B-11).   | ea            | 1                 |
|                  | <b><u>SHOCK MOUNTS</u></b>  |               |                   |
| RA100-SM:        | Shock mount for RA100 amplifier.  | ea            | 1                 |
| RA400-SM:        | Shock mount for RA400 amplifier.  | ea            | 1                 |
| RA1000-SM:       | Shock mount for RA1000 amplifier.   | ea            | 1                 |
| RAT100-SM:       | Shock mount for RAT100 tuner.   | ea            | 1                 |
| RAT400-SM        | Shock mount for RAT400 tuner.   | ea            | 1                 |
| RAT1000-SM       | Shock mount for RAT1000 tuner.  | ea            | 1                 |
|                  | <b><u>VEHICLE MOUNTS</u></b>  |               |                   |
| MT-1099-24       | Vehicle adapter with integral shock mount for installation of PRC1099 into 24-V vehicles. Unit provides power conditioning and surge/reverse polarity protection plus loudspeaker audio and interface to accessory RA100 power amplifier. Mounting dimensions identical with U.S. standard MT-1029/VRC vehicle mount. Order C991580 power cable separately. | ea            | 1                 |
| MT-1099-12       | Vehicle adapter same as MT-1099-24 except for 12-V vehicles.  | ea            | 1                 |



**FIGURE B-1.**  
**Operation of PRC-PS into PRC1099.**



**FIGURE B-2.**  
**Operation of PRC-PS into Separate Battery.**

### **B-3 Installation and Use of Optional Accessory Items**

This section covers the installation and use of the PRC1099 with the following accessories:

1. PRC-PS
2. PRC-BC4
3. PRC-HC-30
4. PRC-SPU-10
5. RA100
6. RA400
7. RA1000
8. MT-1099

### **B-4 Battery Charging Using the PRC-PS Power Supply/Charger**

a. The PRC-PS can charge a battery while it is attached to the radio set, and it can also operate the radio set while charging its battery. Operation is as follows:

1. Attach the transceiver with its battery to the PRC-PS as shown in Figure B-1.

2. Attach the PRC-PS to an appropriate power source, either:

- i) 115/230 Vac, or
- ii) 24 Vdc

3. Turn the transceiver on if both battery charging and radio operation is desired; leave the transceiver off if only battery charging is needed.

4. Turn the PRC-PS on and note the LED indicators:

- i) If the battery is not connected, not connected properly or is shorted, the "fault" LED will come on.
- ii) The "charging" LED will come on during a normal charge cycle.
- iii) The "ready" LED will come on when the battery is fully charged.

b. The PRC-PS can also charge another battery connected to it through a battery connector in the rear of the unit.

1. Attach a BB-LA6 to the PRC-PS as shown in Figure B-2.

2. Attach the PRC-PS to an appropriate power source.

3. Turn the PRC-PS on and note the LED indicators:

- i) If the battery is not connected, not connected properly or is shorted, the "fault" LED will come on.
- ii) The "charging" LED will come on during a normal charge cycle.
- iii) The "ready" LED will come on when the battery is fully charged.

### **B-5 Battery Charging using the PRC-BC4**

a. Charging up to four BB-LA6 sealed lead-calcium battery packs at the same time is done as follows:

1. Attach the PRC-BC4 to an appropriate power source, either:

- i) 115/230 Vac, or
- ii) 24 Vdc

2. Attach the PRC-BC4 to the battery packs to be charged (Figure B-3).

3. Turn the PRC-BC4 on and note the LED indicators:

- i) The "fault" LED will come on if the battery is not connected, not connected properly, or is shorted.
- ii) The "charging" LED will come on during a normal charge cycle.
- iii) The "ready" LED will come on when the battery is fully charged.

### **B-6 Battery Charging Using the PRC-HC-30 Hand Crank Generator**

a) The standard method of battery charging using the PRC-HC-30 is shown in Figure B-4.

1. Attach the BB-LA6 battery needing charging to the PRC1099.

2. Attach the PRC-HC-30 to the PRC1099 transceiver.

3. Mount the PRC-HC-30 for convenient cranking.

4. Begin operating the PRC-HC-30 by rotating its handles.

b. If it is necessary to charge a battery directly from the PRC-HC-30 (Figure B-5):

1. Attach the BB-LA6 to the PRC-HC-30 as shown.

2. Mount the PRC-HC-30 for convenient cranking.

3. Begin operating the PRC-HC-30 by rotating its handles.

### **B-7 Battery Charging Using the PRC-SPU-10 Solar Power Generator**

a. The standard method of battery charging using the PRC-SPU-10 is shown in Figure B-6.

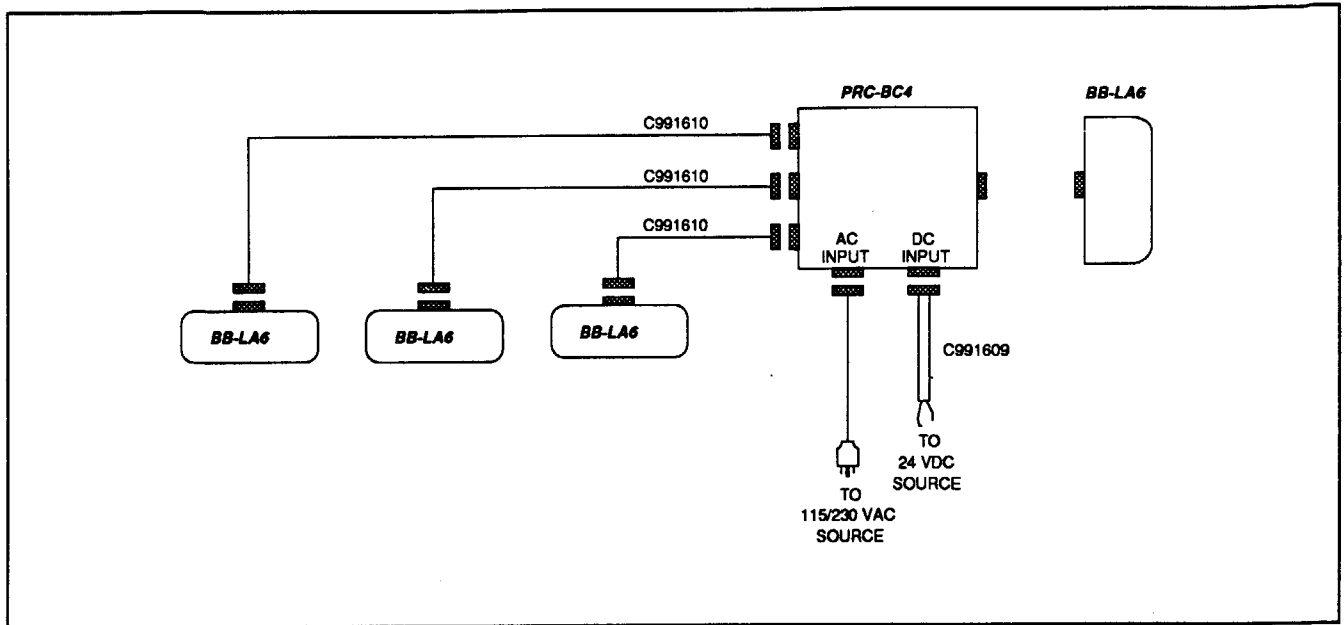
1. Unfold the PRC-SPU-10 and orient it for maximum exposure to the sun.

2. Attach the battery needing charging to the PRC1099.

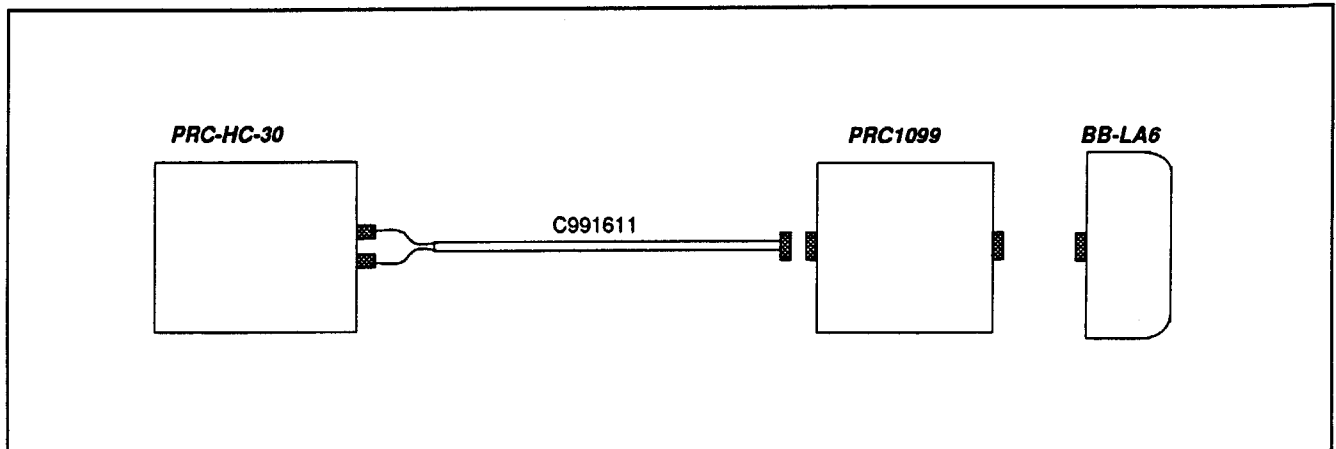
3. Attach the PRC-SPU-10 to the PRC1099 transceiver.

b. If it is necessary to charge a battery directly from the PRC-SPU-10 (Figure B-7):

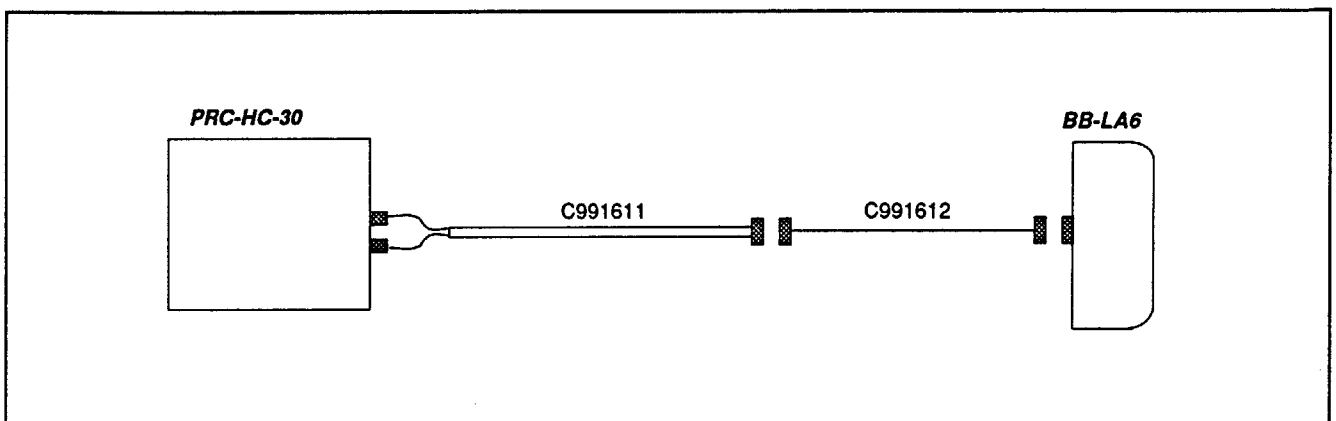
1. Unfold the PRC-SPU-10 and orient it for maximum exposure to the sun.



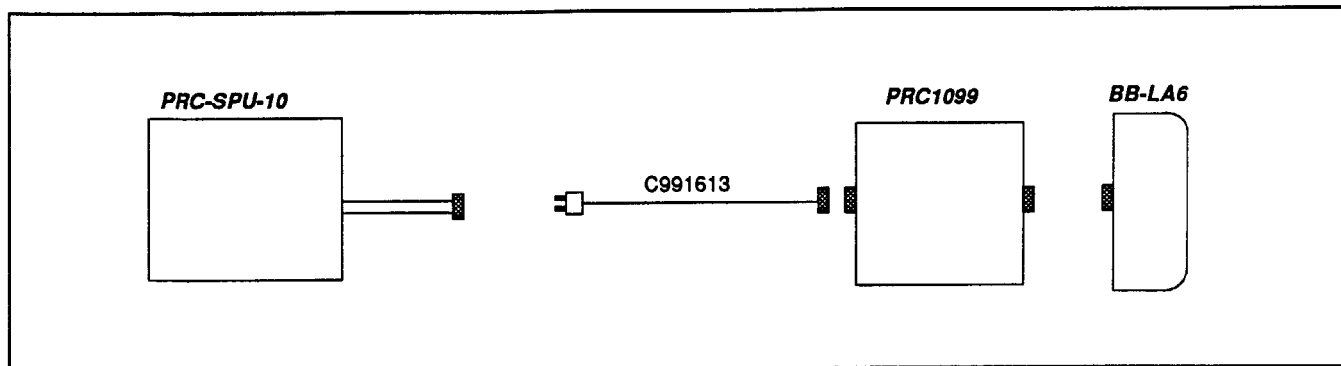
**FIGURE B-3.**  
**Operation of PRC-BC4 with Batteries.**



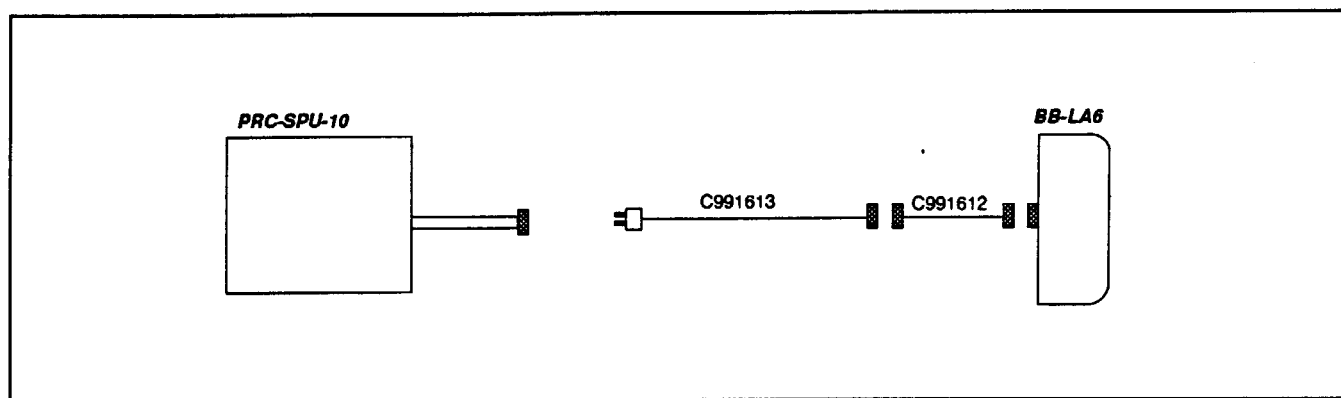
**FIGURE B-4.**  
**Battery Charging Using the PRC-HC-30 and PRC1099.**



**FIGURE B-5.**  
**Battery Charging Using the PRC-HC-30 Directly.**



**FIGURE B-6.**  
**Battery Charging Using the PRC-SPU-10 and PRC1099.**



**FIGURE B-7.**  
**Battery Charging Using the PRC-SPU-10 Directly.**

2. Attach the BB-LA6 to be charged to the PRC-SPU-10.

### B-8 Mobile 20-W System Operation

- a. The PRC1099 can be used in a mobile configuration as shown in Figure B-8.

#### NOTE

This system can be used with either 12- or 24-V vehicles; the only difference is that 12-V vehicle installations must use the MT-1099-12 mount while 24-V vehicle installations must use the MT-1099-24 mount. Everything else, including cabling, is the same.

1. The radio set must have its battery box attached.
2. Slide the PRC1099 into the MT-1099 mount and clamp it in place.
3. Attach the correct cables as indicated in Figure B-8.

### B-9 Mobile 100-W System Operation

- a. The PRC1099 can be used in a mobile configuration with the RA100 power amplifier as shown in Figure B-9.

#### NOTE

As in the 20-W mobile system, 12- or 24-V operation is possible in this configuration also. It is necessary to make

sure the RA100 as well as the MT-1099 is the proper 12- or 24-V model.

1. Attach the battery box to the PRC1099.
2. Slide the PRC1099 into the MT-1099 mount and clamp in place.
3. Attach the RA100 amplifier to the MT-1099 mount.
4. Attach the RAT100 automatic antenna tuner to its shock mount, then mount to the vehicle immediately next to the vehicular antenna.
5. Hook up the correct cables as shown in Figure B-9.

### B-10 Mobile 400-W System Operation

- a. The PRC1099 can be used in a mobile configuration with the RA400 power amplifier as shown in Figure B-10.

#### NOTE

This system can only be used in a 24-V vehicle.

1. Attach the battery box to the PRC1099.
2. Slide the PRC1099 into the MT-1099-24 mount and clamp in place.

3. Attach the RA400 amplifier to its shock mount, and mount to the vehicle.
4. Attach the RAT400 ATU to its shock mount, and then mount to the vehicle immediately next to the antenna.
5. Hook up the correct cables as shown in Figure B-10.

2. Slide the PRC1099 into the MT-1099-24 mount and clamp in place.
3. Attach the RA100-24 amplifier to its shock mount, and mount to the vehicle.
4. Attach the RA1000 amplifier to its shock mount, and mount to the vehicle.
5. Attach the RAT1000 ATU to its shock mount, and the mount to the vehicle immediately next to the antenna.
6. Hook up the correct cables as shown in Figure B-11.

### B-11 Mobile 1000-W System Operation

- a. The PRC1099 can be used in a mobile configuration with the RA1000 power amplifier as shown in Figure B-11.

#### NOTE

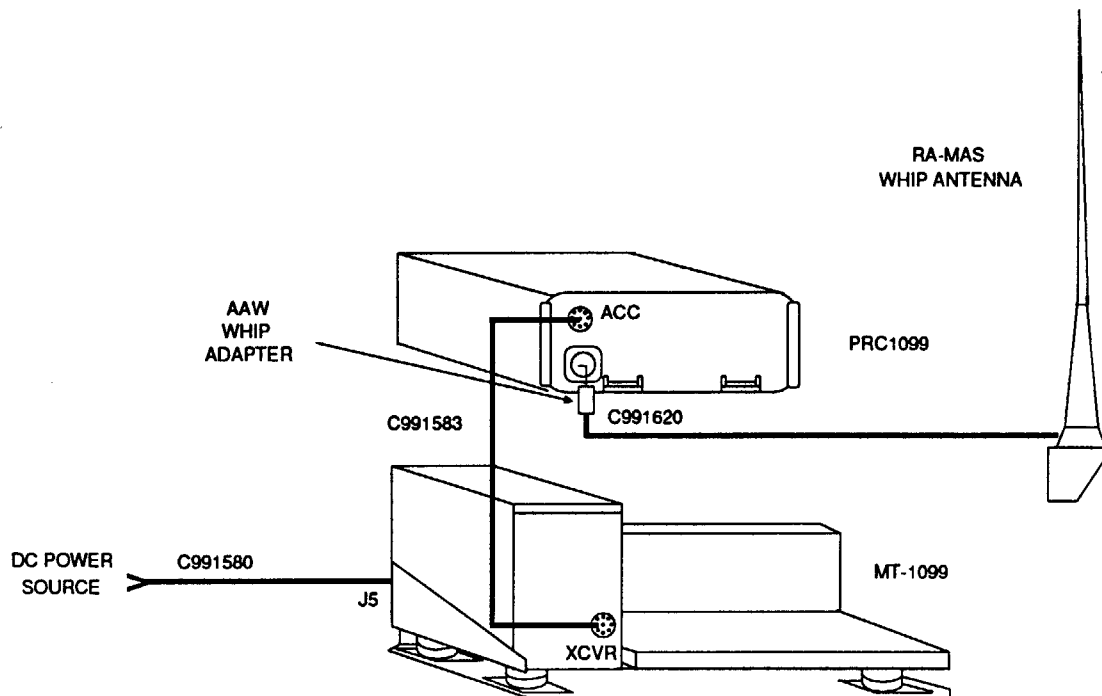
This system can only be used in a 24-V vehicle.

1. Attach the battery box to the PRC1099.

### B-12 Fixed/Portable Station Systems

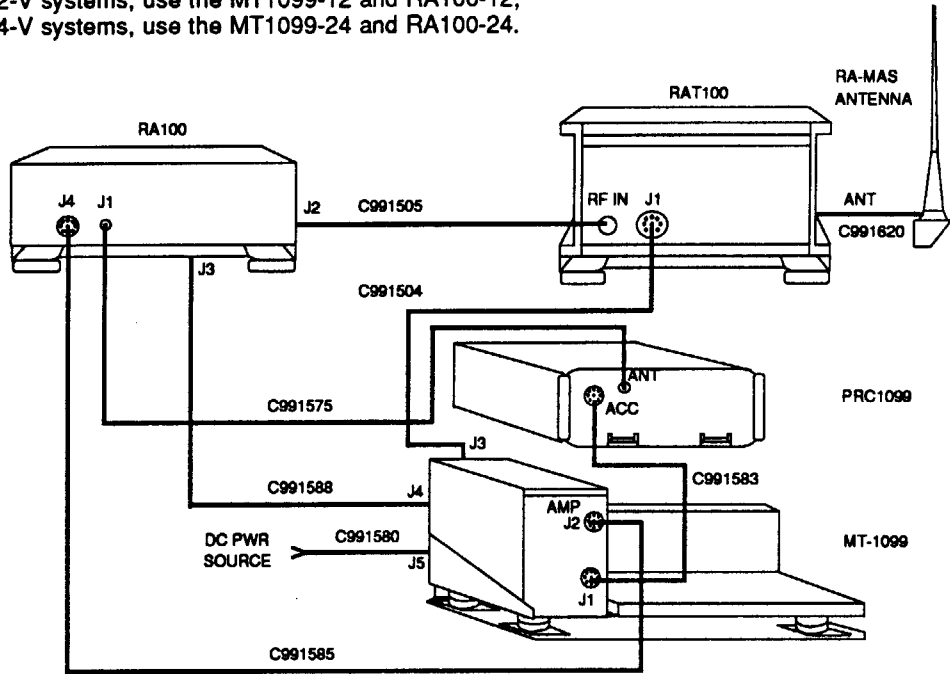
- a. All of the systems previously described can also be

**NOTE:** For 12-V vehicles, use the MT1099-12;  
For 24-V vehicles, use the MT1099-24.

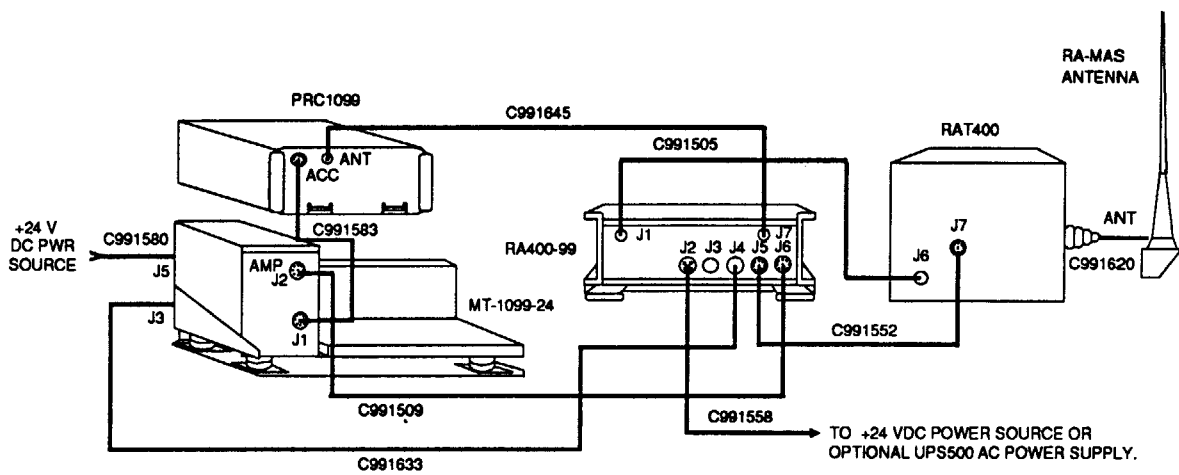


**FIGURE B-8.**  
**Mobile 20-W System.**

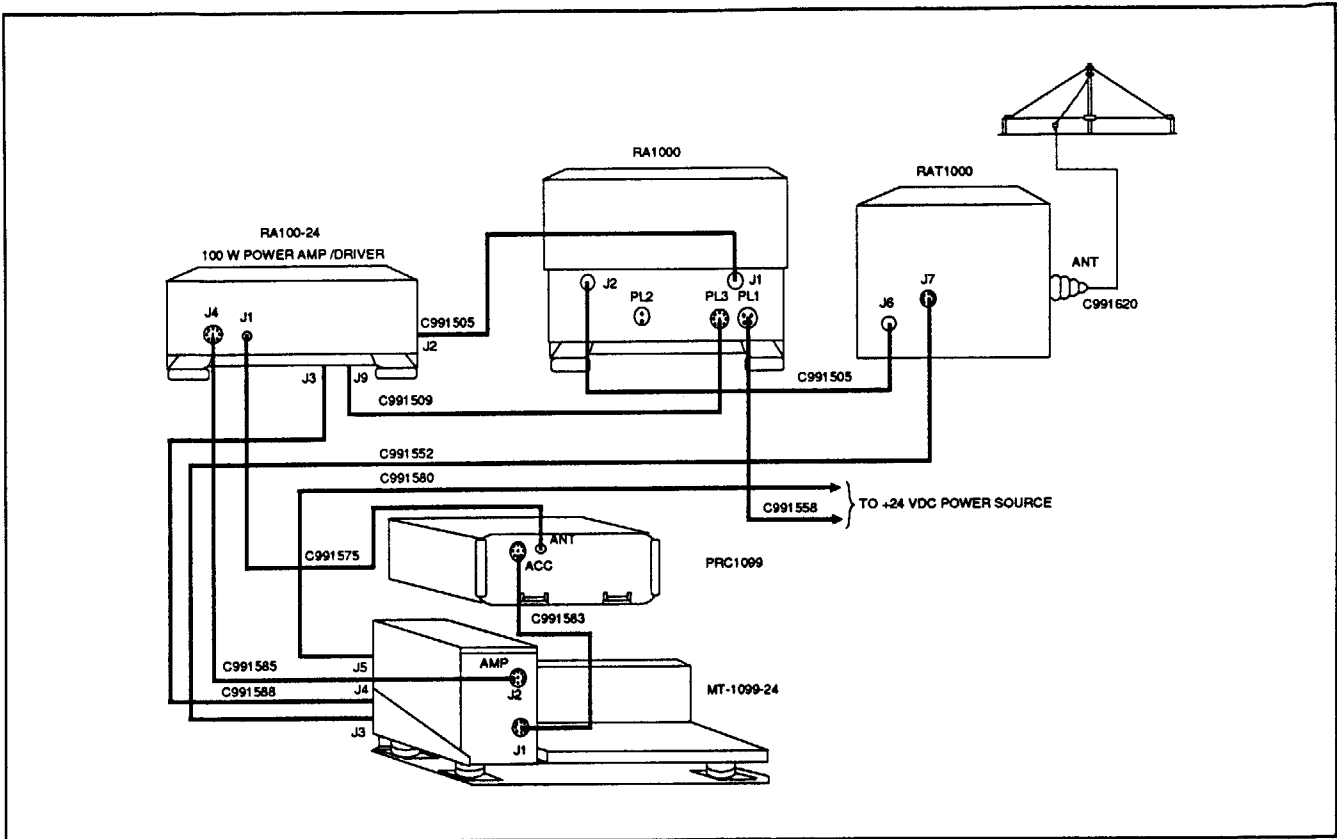
**NOTE:** For 12-V systems, use the MT1099-12 and RA100-12;  
For 24-V systems, use the MT1099-24 and RA100-24.



**FIGURE B-9.**  
**Mobile 100-W System.**



**FIGURE B-10.**  
**Mobile 400-W System.**



**FIGURE B-11.**  
**Mobile 1000-W System.**

used in fixed or portable stations. In these cases the external power must be obtained from ac power sources instead of vehicular supplies.

1. 100-W systems can use the UPS100-12 (for 12-V operation) or UPS100-24 (for 24-V operation) as the primary power source.

Referring to Figure B-9, cable C991580 going between the vehicular power source and the MT-1099 must be replaced with cable C991614. This cable connects the MT-1099 to the UPS100.

2. 400-W systems can use the UPS100 and cable C991614 to power the MT-1099, and also use the UPS500 power supply as the primary power source for the RA400.

Referring to Figure B-10, cable C991580 going between the vehicular power source and the MT-1099 must be replaced with cable C991614; this cable connects the MT-1099 to the UPS100.

Also in Figure B-10, cable C991558 going between the vehicle power source and the RA400 must be replaced with cable C991508; this cable connects the RA400 to the UPS500.

3. 1000-W systems can use the UPS100 and cable C991614 to power the MT-1099, and also use the UPS1000 power supply as the primary power source for the RA1000.

Referring to Figure B-11, cable C991580 going between the vehicular power source and the MT-1099 must be replaced with cable C991614; this cable connects the MT-1099 to the UPS100.

Also in Figure B-11, cable C991558 going between the vehicular power source and the RA1000 must be replaced with cable C991508; this cable connects the RA1000 to the UPS1000.

## APPENDIX C BATTERY TYPES AND ACCESSORY CABLES

**TABLE C-1.  
Battery Types.**

| <b>NON-RECHARGEABLE:</b>  |                              |                        | <b>NOMINAL<br/>OPERATIONAL LIFE<br/>9:1 Receive/<br/>Transmit Ratio</b> |
|---|------------------------------|------------------------|---|
| <b>PART NO.</b>   | <b>TYPE</b>                  | <b>CHARACTERISTICS</b> |   |
| BA-6598/U   | Lithium/Thionyl-Chloride     | 14.4V 14 AMP HRS       | 50 HRS  |
| BA5598/U  | Lithium/Sulfur Dioxide       | 14.4V 7 AMP HRS        | 25 HRS  |
| BA4386/U†   | Magnesium                    | 14.4V 4 AMP HRS        | 14 HRS  |
| <b>RECHARGEABLE:</b>  |                              |                        | <b>NOMINAL<br/>OPERATIONAL LIFE<br/>9:1 Receive/<br/>Transmit Ratio</b> |
| <b>PART NO.</b>   | <b>TYPE</b>                  | <b>CHARACTERISTICS</b> |   |
| BB-LA6  | Sealed Lead-Calcium          | 12V 6 AMP HR           | 20 HRS  |
| BB-NC4  | Nickel Cadmium "D" Cell Pack | 12V 3.6 AMP HR         | 12 HRS  |
| <b>NOTES:</b>   |                              |                        |   |
| † Limited peak current capacity - PRC1099 operates on 5W low power position only when using BA4386/U. |                              |                        |   |

**TABLE C-2.  
Accessory Cables.**

| <b>CABLE P/N</b> | <b>CABLE DESCRIPTION</b>                       | <b>LENGTH</b> |
|------------------|--|---------------|
| C991608          | PRC-PS to PRC1099—power                        | 3 ft          |
| C991609          | External 24 Vdc source to PRC-PS/PRC-BC4—power | 10 ft         |
| C991610          | PRC-BC4 to BB-LA6—power                        | 3 ft          |
| C991611          | PRC-HC-30 to PRC1099—power                     | 6 ft          |
| C991613          | PRC-SPU-10 to PRC1099—power                    | 3 ft          |
| C991617          | PRC-SPU-10 to BBLA6—power                      | 3 ft          |
| C991618          | PRC-HC-30 to BBLA6—power                       | 3 ft          |
| C991580          | External Battery to MT-1099—power              | 10 ft         |
| C991672          | PRC1099 to RAT20 - control                     | 66 ft         |
| C991673          | PRC1099 to RAT20 - RF                          | 66 ft         |
| C991583          | MT-1099 to PRC1099—control                     | 1 ft          |
| C991586          | AAW adaptor to whip—RF                         | 18 in         |

**TABLE C-2.  
Accessory Cables. Continued.**

| CABLE P/N | CABLE DESCRIPTION              | LENGTH |
|-----------|--------------------------------|--------|
| C991588   | MT-1099 to RA100—power         | 18 in  |
| C991585   | MT-1099 to RA100—control       | 18 in  |
| C991504   | MT-1099 to RAT100—control      | 16 ft  |
| C991505   | RA100 to RAT100—RF             | 16 ft  |
| C991620   | RAT100 to whip—RF              | 18 in  |
| C991575   | PRC1099 to RA100—RF            | 8 in   |
| C991558   | External 24 Vdc to RA400—power | 10 ft  |
| C991509   | MT-1099 to RA400—control       | 16 ft  |
| C991552   | RA400 to RAT400—control        | 16 ft  |
| C991510   | PRC1099 to RA400—RF            | 3 ft   |
| C991511   | RA1000 to RA100—power          | 16 ft  |
| C991614   | UPS100 to MT-1099—power        | 3 ft   |
| C991508   | UPS500 to RA400—power          | 3 ft   |

## INDEX

|   | Paragraph | Page |
|---|-----------|------|
| Accessories:  |           |      |
| Performance checklist   | 5-7a      | 5-2  |
| Troubleshooting   | 5-6c      | 5-2  |
| Accessory components  | 1-5b      | 1-2  |
| Antenna:  |           |      |
| End fed antennas:   | 7-4       | 7-1  |
| 50 $\Omega$ antennas  | 7-4a      | 7-1  |
| Remotely tuned antennas   | 7-4b      | 7-1  |
| Installation  | 2-6       | 2-2  |
| Antenna tuner, internal   | 7-2       | 7-1  |
| Antenna tuning  | 5-8d      | 5-4  |
| Antenna tuning procedure  | 3-5       | 3-2  |
| Antijamming   | 3-8       | 3-3  |
| Assembly and installation for manpack operation                   | 2-5       | 2-1  |
| Band check  | 5-7d      | 5-2  |
| BITE - (Built-in Test Equipment) Operation                        | 3-7       | 3-3  |
| Battery:  |           |      |
| Description:  | 1-6       | 1-2  |
| Dry BA4386/U  | 1-6c      | 1-2  |
| Lithium   | 1-6a      | 1-2  |
| Sealed lead-calcium   | 1-6b      | 1-2  |
| Installation  | 2-4       | 2-1  |
| Notes on  | 5-3       | 5-1  |
| Troubleshooting   | 5-6b      | 5-2  |
| Voltage   | 5-8a      | 5-4  |
| Channel frequencies, presetting                                   | 3-2       | 3-2  |
| Channel Selection - Remote  | 3-1       | 3-1  |
| Checking unpacked equipment                                       | 2-2       | 2-1  |
| Cleaning  | 4-6       | 4-2  |
| Controls:   |           |      |
| Performance checklist   | 5-7b      | 5-2  |
| Controls, indicators, and connectors - Transceiver, Radio PRC1099 | 3-1       | 3-1  |
| CW operation  | 3-10      | 3-3  |
| Daily preventive maintenance checks and services chart            | 4-4       | 4-1  |
| End fed antennas  | 7-4       | 7-1  |
| Field maintenance:  |           |      |
| Maintenance intervals   | 5-4       | 5-1  |
| Performance checklist   | 5-7       | 5-2  |
| Preventive maintenance checklist                                  | 5-5       | 5-1  |
| Scope   | 5-1       | 5-1  |
| 50 $\Omega$ antennas  | 7-4a      | 7-1  |
| Frequency calibration   | 5-10      | 5-4  |
| General description:  |           |      |
| Accessory components  | 1-5b      | 1-2  |
| Transceiver, Radio PRC1099  | 1-5a      | 1-2  |
| Ground systems  | 7-3       | 7-1  |
| HF communications   | 6-3       | 6-1  |
| Installation:   |           |      |
| Antenna AT-271A   | 2-6       | 2-2  |
| Battery   | 2-4       | 2-1  |
| Manpack operation   | 2-5       | 2-1  |
| Internal antenna tuner  | 7-2       | 7-1  |
| Internal inspection of the PRC1099                                | 5-9       | 5-4  |

## INDEX (Continued)

|   | Paragraph | Page     |
|---|-----------|----------|
| Items used with PRC1099                                 | 1-4       | 1-1      |
| Jamming, recognition and identification of              | 3-7       | 3-3      |
| Light test  | 5-7f      | 5-2      |
| LSB:  |           |          |
| Lower sideband operation                                | 3-9       | 3-3      |
| Performance checklist                                   | 5-7f      | 5-2      |
| Maintenance intervals                                   | 5-4       | 5-1      |
| Memory check  | 5-7i      | 5-2      |
| Notes on battery  | 5-3       | 5-1      |
| Operating check   | 5-7c      | 5-2      |
| Operating procedure                                     | 3-4       | 3-2      |
| Operational checklist                                   | 4-8       | 4-2      |
| Operator's maintenance:                                 |           |          |
| Scope   | 4-1       | 4-1      |
| Service and inspection periods                          | 4-4       | 4-1, 4-2 |
| Performance checklist                                   | 5-7       | 5-2      |
| Power output  | 5-8b      | 5-4      |
| Power test  | 5-7h      | 5-2      |
| Presetting channel frequencies:                         | 3-2       | 3-2      |
| Presetting channels 1 to 9                              | 3-2a      | 3-2      |
| Presetting man channel                                  | 3-2b      | 3-2      |
| Preventive maintenance:                                 |           |          |
| Checks and services chart:                              |           |          |
| Daily   | 4-4       | 4-1      |
| Weekly  | 4-5       | 4-2      |
| Checklist   | 5-5       | 5-1      |
| Inspection periods                                      | 4-3       | 4-1      |
| Operator's  | 4-2       | 4-1      |
| Purpose and use   | 1-2       | 1-1      |
| Receiver/Exciter performance                            | 5-8c      | 5-4      |
| Receiver fine tune                                      | 3-3       | 3-2      |
| Recognition and identification of jamming               | 3-7       | 3-3      |
| Remotely tuned antennas                                 | 7-4b      | 7-1      |
| Scope:  |           |          |
| Manual  | 1-1       | 1-1      |
| Operator's maintenance                                  | 4-1       | 4-1      |
| Field maintenance                                       | 5-1       | 5-1      |
| Single sideband   | 6-2       | 6-1      |
| Siting  | 2-3       | 2-1      |
| Squelch check   | 5-7e      | 5-2      |
| Stopping procedure                                      | 3-6       | 3-3      |
| System application                                      | 3-11      | 3-3      |
| Technical characteristics                               | 1-3       | 1-1      |
| Tools and accessories                                   | 5-2       | 5-1      |
| Transceiver, Radio PRC1099:                             |           |          |
| Controls, indicators and connectors                     | 3-1       | 3-1      |
| General description                                     | 1-5a      | 1-2      |
| Troubleshooting   | 5-6       | 5-1      |
| Unpacking   | 2-1       | 2-1      |
| Visual inspection                                       | 4-7       | 4-2      |
| Visual inspection, troubleshooting                      | 5-6a      | 5-1      |
| Weekly preventive maintenance checks and services chart | 4-5       | 4-2      |